



# FCC TEST REPORT (15.247)

**REPORT NO.:** RF131113C05

**MODEL NO.:** JWX6082

**FCC ID:** W23-JWX6082

**RECEIVED:** Nov. 13, 2013

**TESTED:** Jan. 10, 2014 ~ Aug. 20, 2014

**ISSUED:** Sep. 02, 2014

**APPLICANT:** jjPlus Corporation

**ADDRESS:** 13F.-3, No 120, Qiaoh Rd. Zhonghe Dist., New Taipei City 23584 Taiwan (R.O.C.)

**ISSUED BY:** Bureau Veritas Consumer Products Services (H.K.) Ltd., Taoyuan Branch

**LAB ADDRESS:** No. 47, 14th Ling, Chia Pau Vil., Lin Kou Dist., New Taipei City, Taiwan ( R.O.C )

**TEST LOCATION:** No. 19, Hwa Ya 2nd Rd, Wen Hwa Tsuen, Kwei Shan Hsiang, Taoyuan Hsien 333, Taiwan, R.O.C.

This report should not be used by the client to claim product certification, approval, or endorsement by TAF or any government agencies.



This report is for your exclusive use. Any copying or replication of this report to or for any other person or entity, or use of our name or trademark, is permitted only with our prior written permission. This report sets forth our findings solely with respect to the test samples identified herein. The results set forth in this report are not indicative or representative of the quality or characteristics of the lot from which a test sample was taken or any similar or identical product unless specifically and expressly noted. Our report includes all of the tests requested by you and the results thereof based upon the information that you provided to us. You have 60 days from date of issuance of this report to notify us of any material error or omission caused by our negligence, provided, however, that such notice shall be in writing and shall specifically address the issue you wish to raise. A failure to raise such issue within the prescribed time shall constitute your unqualified acceptance of the completeness of this report, the tests conducted and the correctness of the report contents. Unless specific mention, the uncertainty of measurement has been explicitly taken into account to declare the compliance or non-compliance to the specification.



# TABLE OF CONTENTS

RELEASE CONTROL RECORD .....	4
1. CERTIFICATION.....	5
2. SUMMARY OF TEST RESULTS .....	6
2.1 MEASUREMENT UNCERTAINTY.....	6
3. GENERAL INFORMATION .....	7
3.1 GENERAL DESCRIPTION OF EUT .....	7
3.2 DESCRIPTION OF TEST MODES .....	8
3.2.1 TEST MODE APPLICABILITY AND TESTED CHANNEL DETAIL.....	9
3.3 DESCRIPTION OF SUPPORT UNITS .....	13
3.3.1 CONFIGURATION OF SYSTEM UNDER TEST .....	13
3.4 DUTY CYCLE TEST SIGNAL.....	14
3.5 GENERAL DESCRIPTION OF APPLIED STANDARDS .....	17
4. TEST TYPES AND RESULTS (FOR 2.4GHz BAND).....	18
4.1 RADIATED EMISSION AND BANDEDGE MEASUREMENT .....	18
4.1.1 LIMITS OF RADIATED EMISSION AND BANDEDGE MEASUREMENT .....	18
4.1.2 TEST INSTRUMENTS.....	19
4.1.3 TEST PROCEDURES .....	20
4.1.4 DEVIATION FROM TEST STANDARD .....	20
4.1.5 TEST SETUP .....	21
4.1.6 EUT OPERATING CONDITIONS .....	22
4.1.7 TEST RESULTS.....	23
4.2 6dB BANDWIDTH MEASUREMENT .....	42
4.2.1 LIMITS OF 6dB BANDWIDTH MEASUREMENT .....	42
4.2.2 TEST SETUP .....	42
4.2.3 TEST INSTRUMENTS.....	42
4.2.4 TEST PROCEDURE .....	42
4.2.5 DEVIATION FROM TEST STANDARD .....	42
4.2.6 EUT OPERATING CONDITIONS .....	42
4.2.7 TEST RESULTS.....	43
4.3 CONDUCTED OUTPUT POWER .....	46
4.3.1 LIMITS OF CONDUCTED OUTPUT POWER MEASUREMENT.....	46
4.3.2 TEST SETUP .....	46
4.3.3 TEST INSTRUMENTS.....	46
4.3.4 TEST PROCEDURES .....	46
4.3.5 DEVIATION FROM TEST STANDARD .....	46
4.3.6 EUT OPERATING CONDITIONS .....	46
4.3.7 TEST RESULTS.....	47
4.4 POWER SPECTRAL DENSITY MEASUREMENT.....	49
4.4.1 LIMITS OF POWER SPECTRAL DENSITY MEASUREMENT .....	49
4.4.2 TEST SETUP .....	49
4.4.3 TEST INSTRUMENTS.....	49
4.4.4 TEST PROCEDURE .....	49
4.4.5 DEVIATION FROM TEST STANDARD .....	49
4.4.6 EUT OPERATING CONDITION.....	49
4.4.7 TEST RESULTS.....	50
4.5 CONDUCTED OUT OF BAND EMISSION MEASUREMENT .....	53
4.5.1 LIMITS OF CONDUCTED OUT OF BAND EMISSION MEASUREMENT .....	53
4.5.2 TEST SETUP .....	53
4.5.3 TEST INSTRUMENTS.....	53
4.5.4 TEST PROCEDURE .....	53
4.5.5 DEVIATION FROM TEST STANDARD .....	53
4.5.6 EUT OPERATING CONDITION.....	53



4.5.7	TEST RESULTS.....	54
5.	TEST TYPES AND RESULTS (FOR 5.0GHz BAND) .....	64
5.1	RADIATED EMISSION AND BANDEDGE MEASUREMENT .....	64
5.1.1	LIMITS OF RADIATED EMISSION AND BANDEDGE MEASUREMENT .....	64
5.1.2	TEST INSTRUMENTS.....	65
5.1.3	TEST PROCEDURES .....	65
5.1.4	DEVIATION FROM TEST STANDARD .....	65
5.1.5	TEST SETUP.....	65
5.1.6	EUT OPERATING CONDITIONS .....	65
5.1.7	TEST RESULTS.....	66
5.2	6dB BANDWIDTH MEASUREMENT .....	80
5.2.1	LIMITS OF 6dB BANDWIDTH MEASUREMENT .....	80
5.2.2	TEST SETUP.....	80
5.2.3	TEST INSTRUMENTS.....	80
5.2.4	TEST PROCEDURE.....	80
5.2.5	DEVIATION FROM TEST STANDARD .....	80
5.2.6	EUT OPERATING CONDITIONS .....	80
5.2.7	TEST RESULTS.....	81
5.3	MAXIMUM OUTPUT POWER .....	83
5.3.1	LIMITS OF MAXIMUM OUTPUT POWER MEASUREMENT .....	83
5.3.2	TEST SETUP.....	83
5.3.3	INSTRUMENTS.....	83
5.3.4	TEST PROCEDURES .....	83
5.3.5	DEVIATION FROM TEST STANDARD .....	83
5.3.6	EUT OPERATING CONDITIONS .....	83
5.3.7	TEST RESULTS.....	84
5.4	POWER SPECTRAL DENSITY MEASUREMENT.....	86
5.4.1	LIMITS OF POWER SPECTRAL DENSITY MEASUREMENT .....	86
5.4.2	TEST SETUP.....	86
5.4.3	TEST INSTRUMENTS.....	86
5.4.4	TEST PROCEDURE.....	86
5.4.5	DEVIATION FROM TEST STANDARD .....	86
5.4.6	EUT OPERATING CONDITION.....	86
5.4.7	TEST RESULTS.....	87
5.5	CONDUCTED OUT OF BAND EMISSION MEASUREMENT .....	90
5.5.1	LIMITS OF OUT OF BAND EMISSION MEASUREMENT .....	90
5.5.2	TEST SETUP.....	90
5.5.3	TEST INSTRUMENTS.....	90
5.5.4	TEST PROCEDURE.....	90
5.5.5	DEVIATION FROM TEST STANDARD .....	90
5.5.6	EUT OPERATING CONDITION.....	90
5.5.7	TEST RESULTS.....	90
6.	PHOTOGRAPHS OF THE TEST CONFIGURATION.....	100
7.	INFORMATION ON THE TESTING LABORATORIES .....	101
8.	APPENDIX A – MODIFICATIONS RECORDERS FOR ENGINEERING CHANGES TO THE EUT BY THE LAB .....	102



A D T

## RELEASE CONTROL RECORD

ISSUE NO.	REASON FOR CHANGE	DATE ISSUED
RF131113C05	Original release	Sep. 02, 2014



## 1. CERTIFICATION

**PRODUCT:** 802.11a/b/g/n 3T3R Mini-PCI Express Module  
**MODEL NO.:** JWX6082  
**BRAND:** jjPlus  
**APPLICANT:** jjPlus Corporation  
**TESTED:** Jan. 10, 2014 ~ Aug. 20, 2014  
**TEST SAMPLE:** ENGINEERING SAMPLE  
**STANDARDS:** **FCC Part 15, Subpart C (Section 15.247)**  
ANSI C63.10-2009

The above equipment (model: JWX6082) has been tested by **Bureau Veritas Consumer Products Services (H.K.) Ltd., Taoyuan Branch**, and found compliance with the requirement of the above standards. The test record, data evaluation & Equipment Under Test (EUT) configurations represented herein are true and accurate accounts of the measurements of the sample's EMC characteristics under the conditions specified in this report.

**PREPARED BY** : Evonne Liu , **DATE** : Sep. 02, 2014  
Evonne Liu / Specialist

**APPROVED BY** : Sam Chen , **DATE** : Sep. 02, 2014  
Sam Chen / Senior Project Engineer

## 2. SUMMARY OF TEST RESULTS

The EUT has been tested according to the following specifications:

APPLIED STANDARD: FCC PART 15, SUBPART C (SECTION 15.247)			
STANDARD SECTION	TEST TYPE	RESULT	REMARK
15.207	AC Power Conducted Emission	N/A	Test not applicable because of not ancillary equipment.
15.205 & 15.209	Radiated Emissions	PASS	Meet the requirement of limit. Minimum passing margin is -1.06dB at 2484MHz.
15.247(d)	Band Edge Measurement	PASS	Meet the requirement of limit.
15.247(d)	Antenna Port Emission	PASS	Meet the requirement of limit.
15.247(a)(2)	6dB bandwidth	PASS	Meet the requirement of limit.
15.247(b)	Conducted power	PASS	Meet the requirement of limit.
15.247(e)	Power Spectral Density	PASS	Meet the requirement of limit.
15.203	Antenna Requirement	PASS	Antenna connector is I-pex.

### 2.1 MEASUREMENT UNCERTAINTY

Where relevant, the following measurement uncertainty levels have been estimated for tests performed on the EUT as specified in CISPR 16-4-2:

MEASUREMENT	FREQUENCY	UNCERTAINTY
Radiated emissions	30MHz ~ 200MHz	2.93 dB
	200MHz ~1000MHz	2.95 dB
	1GHz ~ 18GHz	2.26 dB
	18GHz ~ 40GHz	1.94 dB

This uncertainty represents an expanded uncertainty expressed at approximately the 95% confidence level using a coverage factor of  $k = 2$ .



A D T

### 3. GENERAL INFORMATION

#### 3.1 GENERAL DESCRIPTION OF EUT

<b>EUT</b>	802.11a/b/g/n 3T3R Mini-PCI Express Module
<b>MODEL NO.</b>	JWX6082
<b>POWER SUPPLY</b>	5.0Vdc (host equipment)
<b>MODULATION TYPE</b>	CCK, DQPSK, DBPSK for DSSS 64QAM, 16QAM, QPSK, BPSK for OFDM
<b>MODULATION TECHNOLOGY</b>	DSSS, OFDM
<b>TRANSFER RATE</b>	802.11b: 11.0 / 5.5 / 2.0 / 1.0 Mbps 802.11g: 54.0 / 48.0 / 36.0 / 24.0 / 18.0 / 12.0 / 9.0 / 6.0 Mbps 802.11a: 54.0 / 48.0 / 36.0 / 24.0 / 18.0 / 12.0 / 9.0 / 6.0 Mbps 802.11n: up to MCS7
<b>OPERATING FREQUENCY</b>	<b>2.4GHz:</b> 2412 ~ 2462MHz <b>5.0GHz:</b> 5745 ~ 5805MHz
<b>NUMBER OF CHANNEL</b>	<b>2.4GHz:</b> 11 for 802.11b, 802.11g, 802.11n (20MHz) 7 for 802.11n (40MHz) <b>5.0GHz:</b> 4 for 802.11a, 802.11n (20MHz) 2 for 802.11n (40MHz)
<b>OUTPUT POWER</b>	226.923mW for 2412 ~ 2462MHz 296.484mW for 5745 ~ 5805MHz
<b>ANTENNA TYPE</b>	Dipole antenna with 2dBi gain
<b>ANTENNA CONNECTOR</b>	NA
<b>DATA CABLE</b>	Refer to Note as below
<b>I/O PORTS</b>	Refer to user's manual
<b>ACCESSORY DEVICES</b>	Refer to Note as below

**NOTE:**

1. The EUT incorporates a MIMO function. Physically, the EUT provides three completed transmitters and three receivers.

MODULATION MODE	TX FUNCTION
802.11b	1TX
802.11g	1TX
802.11a	1TX
802.11n (20MHz)	1TX, 2TX, 3TX
802.11n (40MHz)	1TX, 2TX, 3TX

2. The above EUT information is declared by the manufacturer and for more detailed features description, please refer to the manufacturer's specifications or User's Manual.



A D T

### 3.2 DESCRIPTION OF TEST MODES

#### FOR 2.4GHz:

11 channels are provided for 802.11b, 802.11g and 802.11n (20MHz):

CHANNEL	FREQUENCY	CHANNEL	FREQUENCY
1	2412MHz	7	2442MHz
2	2417MHz	8	2447MHz
3	2422MHz	9	2452MHz
4	2427MHz	10	2457MHz
5	2432MHz	11	2462MHz
6	2437MHz		

7 channels are provided for 802.11n (40MHz):

CHANNEL	FREQUENCY	CHANNEL	FREQUENCY
3	2422MHz	7	2442MHz
4	2427MHz	8	2447MHz
5	2432MHz	9	2452MHz
6	2437MHz		

#### FOR 5.0GHz (5745 ~ 5805MHz):

4 channels are provided for 802.11a, 802.11n (20MHz):

CHANNEL	FREQUENCY	CHANNEL	FREQUENCY
149	5745MHz	157	5785MHz
153	5765MHz	161	5805MHz

2 channels are provided for 802.11n (40MHz):

CHANNEL	FREQUENCY	CHANNEL	FREQUENCY
151	5755MHz	159	5795MHz





A D T

### 3.2.1 TEST MODE APPLICABILITY AND TESTED CHANNEL DETAIL

#### WLAN 2.4GHz:

EUT CONFIGURE MODE	APPLICABLE TO			DESCRIPTION
	RE≥1G	RE<1G	APCM	
A	√	√	√	1TX
B	-	-	√	2TX
C	√	-	√	3TX

Where **RE≥1G**: Radiated Emission above 1GHz      **RE<1G**: Radiated Emission below 1GHz  
**APCM**: Antenna Port Conducted Measurement

#### RADIATED EMISSION TEST (ABOVE 1GHz):

- Pre-Scan has been conducted to determine the worst-case mode from all possible combinations between available modulations, data rates and antenna ports (if EUT with antenna diversity architecture).
- Following channel(s) was (were) selected for the final test as listed below.

EUT CONFIGURE MODE	MODE	AVAILABLE CHANNEL	TESTED CHANNEL	MODULATION TECHNOLOGY	MODULATION TYPE	DATA RATE (Mbps)
A	802.11b	1 to 11	1, 6, 11	DSSS	DBPSK	1.0
	802.11g	1 to 11	1, 6, 11	OFDM	BPSK	6.0
	802.11n (20MHz)	1 to 11	1, 6, 11	OFDM	BPSK	MCS0
	802.11n (40MHz)	3 to 9	3, 6, 9	OFDM	BPSK	MCS0
C	802.11n (20MHz)	1 to 11	1, 6, 11	OFDM	BPSK	MCS0
	802.11n (40MHz)	3 to 9	3, 6, 9	OFDM	BPSK	MCS0

#### RADIATED EMISSION TEST (BELOW 1GHz):

- Pre-Scan has been conducted to determine the worst-case mode from all possible combinations between available modulations, data rates and antenna ports (if EUT with antenna diversity architecture).
- Following channel(s) was (were) selected for the final test as listed below.

EUT CONFIGURE MODE	MODE	AVAILABLE CHANNEL	TESTED CHANNEL	MODULATION TECHNOLOGY	MODULATION TYPE	DATA RATE (Mbps)
A	802.11b	1 to 11	1	OFDM	BPSK	MCS0



**BANDEDGE MEASUREMENT:**

- Pre-Scan has been conducted to determine the worst-case mode from all possible combinations between available modulations, data rates and antenna ports (if EUT with antenna diversity architecture).
- Following channel(s) was (were) selected for the final test as listed below.

EUT CONFIGURE MODE	MODE	AVAILABLE CHANNEL	TESTED CHANNEL	MODULATION TECHNOLOGY	MODULATION TYPE	DATA RATE (Mbps)
A	802.11b	1 to 11	1, 6, 11	DSSS	DBPSK	1.0
	802.11g	1 to 11	1, 6, 11	OFDM	BPSK	6.0
	802.11n (20MHz)	1 to 11	1, 6, 11	OFDM	BPSK	MCS0
	802.11n (40MHz)	3 to 9	3, 6, 9	OFDM	BPSK	MCS0
C	802.11n (20MHz)	1 to 11	1, 6, 11	OFDM	BPSK	MCS0
	802.11n (40MHz)	3 to 9	3, 6, 9	OFDM	BPSK	MCS0

**ANTENNA PORT CONDUCTED MEASUREMENT:**

- This item includes all test value of each mode, but only includes spectrum plot of worst value of each mode.
- Pre-Scan has been conducted to determine the worst-case mode from all possible combinations between available modulations, data rates and antenna ports (if EUT with antenna diversity architecture).
- Following channel(s) was (were) selected for the final test as listed below.

EUT CONFIGURE MODE	MODE	AVAILABLE CHANNEL	TESTED CHANNEL	MODULATION TECHNOLOGY	MODULATION TYPE	DATA RATE (Mbps)
A	802.11b	1 to 11	1, 6, 11	DSSS	DBPSK	1.0
	802.11g	1 to 11	1, 6, 11	OFDM	BPSK	6.0
	802.11n (20MHz)	1 to 11	1, 6, 11	OFDM	BPSK	MCS0
	802.11n (40MHz)	3 to 9	3, 6, 9	OFDM	BPSK	MCS0
B, C	802.11n (20MHz)	1 to 11	1, 6, 11	OFDM	BPSK	MCS0
	802.11n (40MHz)	3 to 9	3, 6, 9	OFDM	BPSK	MCS0

**TEST CONDITION:**

APPLICABLE TO	ENVIRONMENTAL CONDITIONS	INPUT POWER	TESTED BY
RE≥1G	25deg. C, 65%RH	120Vac, 60Hz	Kay Wu
RE<1G	25deg. C, 65%RH	120Vac, 60Hz	Kay Wu
APCM	25deg. C, 65%RH	120Vac, 60Hz	Howard Kao



A D T

**WLAN 5GHz:**

EUT CONFIGURE MODE	APPLICABLE TO			DESCRIPTION
	RE≥1G	RE<1G	APCM	
A	√	√	√	1TX
B	-	-	√	2TX
C	√	-	√	3TX

Where **RE≥1G**: Radiated Emission above 1GHz **RE<1G**: Radiated Emission below 1GHz  
**APCM**: Antenna Port Conducted Measurement

**RADIATED EMISSION TEST (ABOVE 1GHz):**

- Pre-Scan has been conducted to determine the worst-case mode from all possible combinations between available modulations, data rates and antenna ports (if EUT with antenna diversity architecture).
- Following channel(s) was (were) selected for the final test as listed below.

EUT CONFIGURE MODE	MODE	FREQ. BAND (MHz)	AVAILABLE CHANNEL	TESTED CHANNEL	MODULATION TECHNOLOGY	MODULATION TYPE	DATA RATE (Mbps)
A	802.11a	5745-5805	149 to 161	149, 157, 161	OFDM	BPSK	6.0
	802.11n (20MHz)		149 to 161	149, 157, 161	OFDM	BPSK	MCS0
	802.11n (40MHz)		151 to 159	151, 159	OFDM	BPSK	MCS0
C	802.11n (20MHz)	5745-5805	149 to 161	149, 157, 161	OFDM	BPSK	MCS0
	802.11n (40MHz)		151 to 159	151, 159	OFDM	BPSK	MCS0

**RADIATED EMISSION TEST (BELOW 1GHz):**

- Pre-Scan has been conducted to determine the worst-case mode from all possible combinations between available modulations, data rates and antenna ports (if EUT with antenna diversity architecture).
- Following channel(s) was (were) selected for the final test as listed below.

EUT CONFIGURE MODE	MODE	FREQ. BAND (MHz)	AVAILABLE CHANNEL	TESTED CHANNEL	MODULATION TECHNOLOGY	MODULATION TYPE	DATA RATE (Mbps)
A	802.11a	5745-5805	149 to 161	149	OFDM	BPSK	6.0



**BANDEDGE MEASUREMENT:**

- Pre-Scan has been conducted to determine the worst-case mode from all possible combinations between available modulations, data rates and antenna ports (if EUT with antenna diversity architecture).
- Following channel(s) was (were) selected for the final test as listed below.

EUT CONFIGURE MODE	MODE	FREQ. BAND (MHz)	AVAILABLE CHANNEL	TESTED CHANNEL	MODULATION TECHNOLOGY	MODULATION TYPE	DATA RATE (Mbps)
A	802.11a	5745-5805	149 to 161	149, 157, 161	OFDM	BPSK	6.0
	802.11n (20MHz)		149 to 161	149, 157, 161	OFDM	BPSK	MCS0
	802.11n (40MHz)		151 to 159	151, 159	OFDM	BPSK	MCS0
C	802.11n (20MHz)	5745-5805	149 to 161	149, 157, 161	OFDM	BPSK	MCS0
	802.11n (40MHz)		151 to 159	151, 159	OFDM	BPSK	MCS0

**ANTENNA PORT CONDUCTED MEASUREMENT:**

- This item includes all test value of each mode, but only includes spectrum plot of worst value of each mode.
- Pre-Scan has been conducted to determine the worst-case mode from all possible combinations between available modulations, data rates and antenna ports (if EUT with antenna diversity architecture).
- Following channel(s) was (were) selected for the final test as listed below.

EUT CONFIGURE MODE	MODE	FREQ. BAND (MHz)	AVAILABLE CHANNEL	TESTED CHANNEL	MODULATION TECHNOLOGY	MODULATION TYPE	DATA RATE (Mbps)
A	802.11a	5745-5805	149 to 161	149, 157, 161	OFDM	BPSK	6.0
	802.11n (20MHz)		149 to 161	149, 157, 161	OFDM	BPSK	MCS0
	802.11n (40MHz)		151 to 159	151, 159	OFDM	BPSK	MCS0
B, C	802.11n (20MHz)	5745-5805	149 to 161	149, 157, 161	OFDM	BPSK	MCS0
	802.11n (40MHz)		151 to 159	151, 159	OFDM	BPSK	MCS0

**Test CONDITION:**

APPLICABLE TO	ENVIRONMENTAL CONDITIONS	INPUT POWER	TESTED BY
RE≥1G	25deg. C, 65%RH	120Vac, 60Hz	Kay Wu
RE<1G	25deg. C, 65%RH	120Vac, 60Hz	Kay Wu
APCM	25deg. C, 65%RH	120Vac, 60Hz	David Huang

### 3.3 DESCRIPTION OF SUPPORT UNITS

The EUT has been tested as an independent unit together with other necessary accessories or support units.

#### 3.3.1 CONFIGURATION OF SYSTEM UNDER TEST

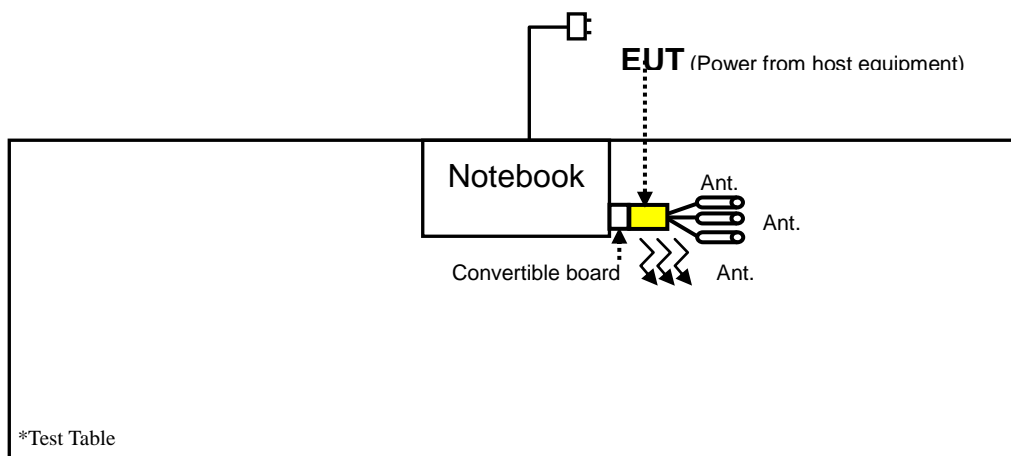

### 3.4 DUTY CYCLE TEST SIGNAL

#### WLAN 2.4GHz

#### MODE A

**802.11b:** Duty cycle of test signal is 100 %

Duty cycle is < 98%

**802.11g:** Duty cycle = 1.343/1.408 = 0.954, Duty factor =  $10 * \log(1/0.954) = 0.20$

**802.11n (20MHz):** Duty cycle = 1.265/1.329 = 0.951, Duty factor =  $10 * \log(1/0.951) = 0.22$

**802.11n (40MHz):** Duty cycle = 591/673 = 0.878, Duty factor =  $10 * \log(1/0.878) = 0.57$

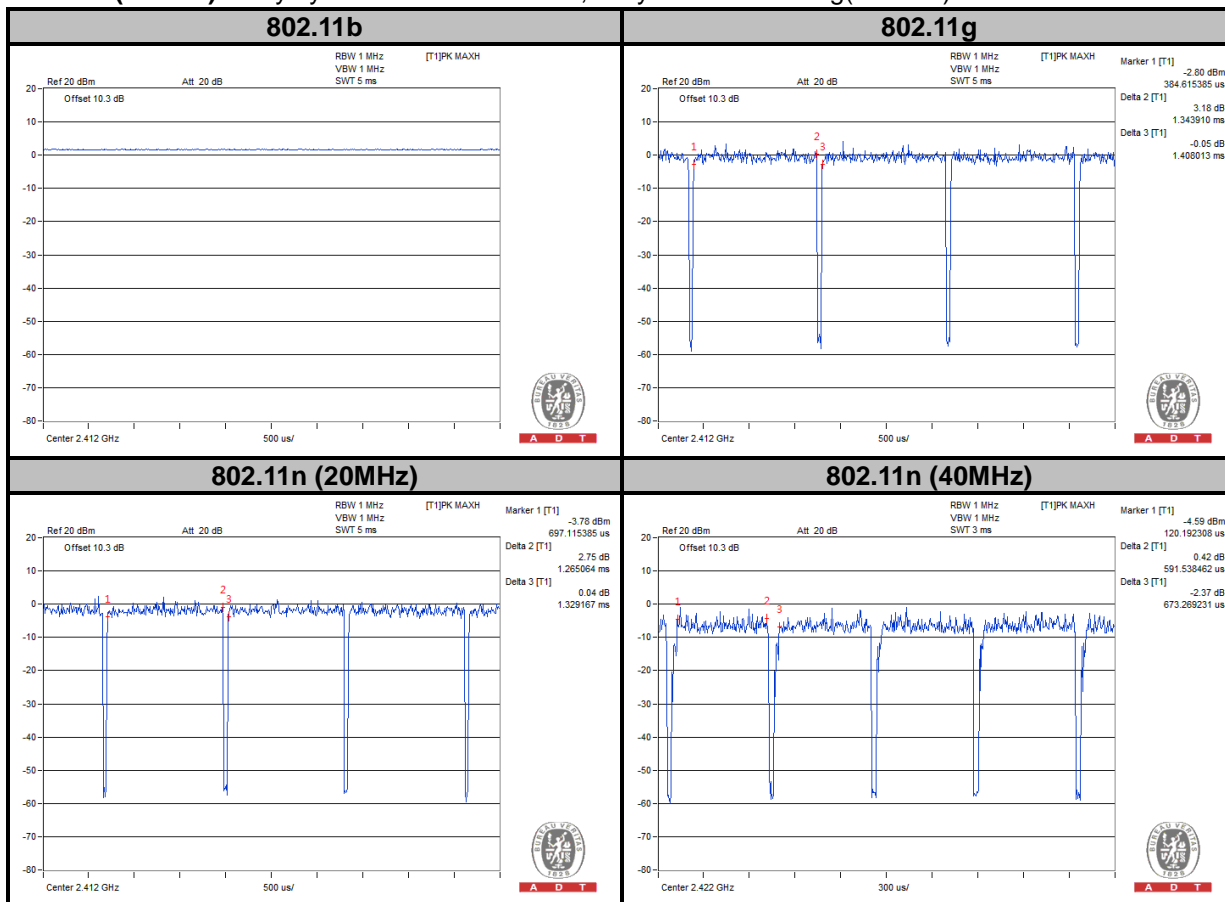



A D T

### MODE C

**802.11n (20MHz):** Duty cycle =  $1.258/1.322 = 0.951$ , Duty factor =  $10 * \log(1/0.951) = 0.22$

**802.11n (40MHz):** Duty cycle =  $599/676 = 0.886$ , Duty factor =  $10 * \log(1/0.886) = 0.53$

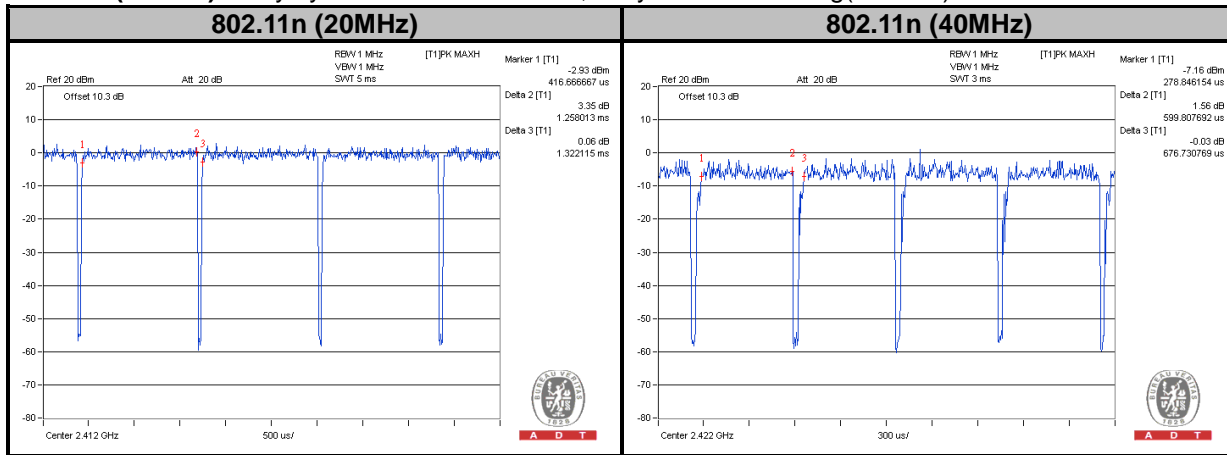



A D T

### 5745MHz ~ 5805MHz

#### MODE A

**802.11a:** Duty cycle = 1.354/1.410 = 0.960, Duty factor =  $10 * \log(1/0.960) = 0.17$

**802.11n (20MHz):** Duty cycle = 1.258/1.314 = 0.957, Duty factor =  $10 * \log(1/0.957) = 0.18$

**802.11n (40MHz):** Duty cycle = 605/677 = 0.893, Duty factor =  $10 * \log(1/0.893) = 0.48$

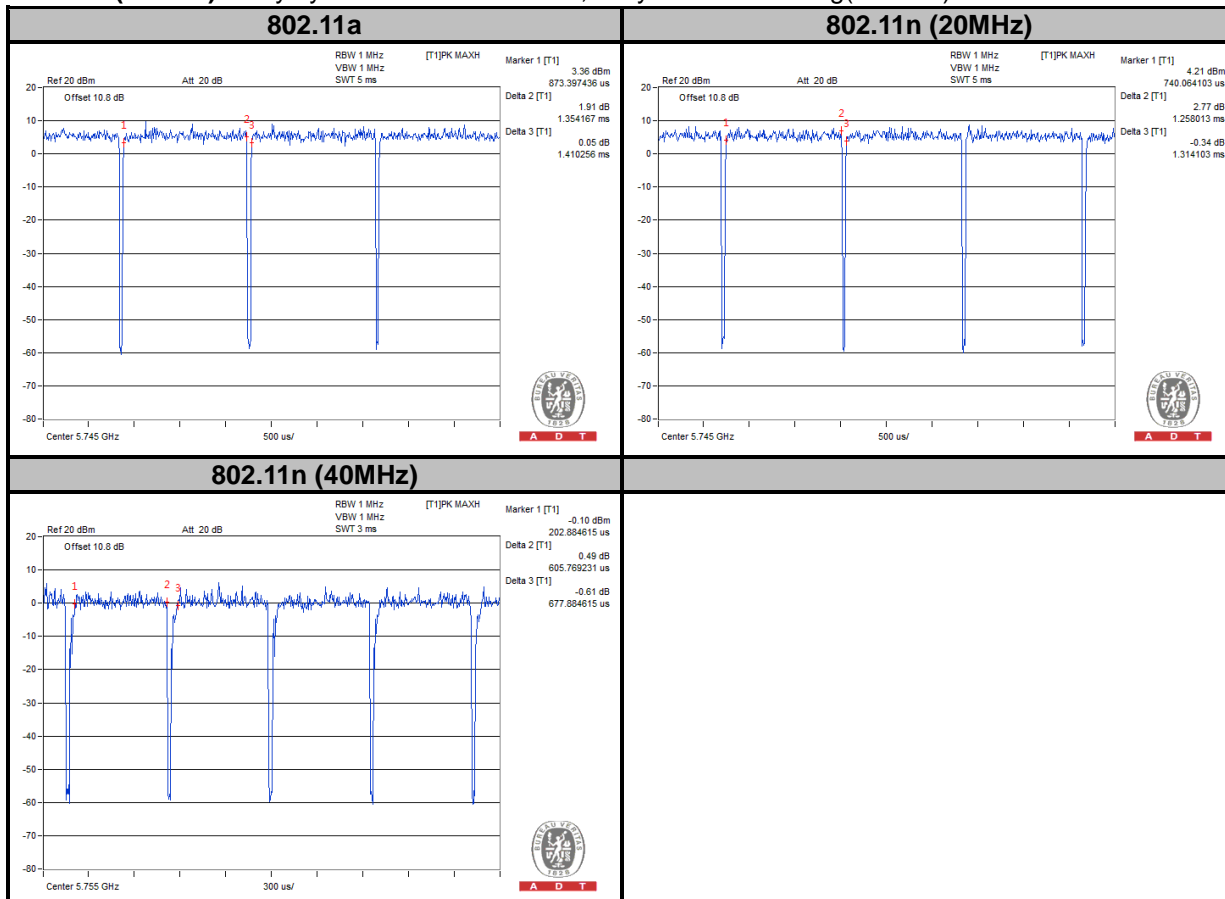

#### MODE C

**802.11n (20MHz):** Duty cycle = 1.266/1.322 = 0.957, Duty factor =  $10 * \log(1/0.957) = 0.18$

**802.11n (40MHz):** Duty cycle = 600/673 = 0.892, Duty factor =  $10 * \log(1/0.892) = 0.49$

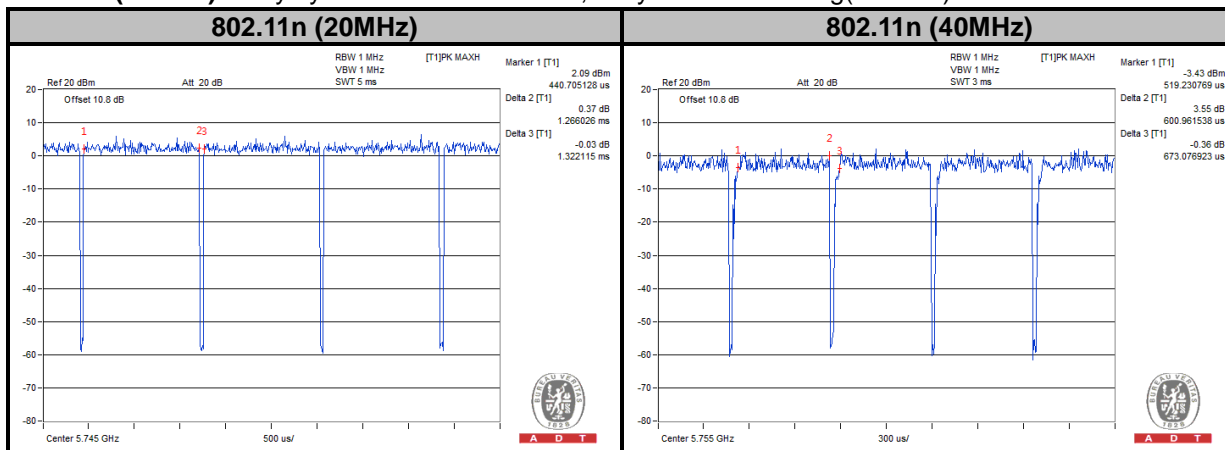



### 3.5 GENERAL DESCRIPTION OF APPLIED STANDARDS

The EUT is a RF Product. According to the specifications of the manufacturer, it must comply with the requirements of the following standards:

**FCC Part 15, Subpart C (15.247)**

**558074 D01 DTS Meas Guidance v03r02**

**662911 D01 Multiple Transmitter Output v02r01**

ANSI C63.10-2009

All test items have been performed and recorded as per the above standards.

**NOTE:** The EUT is also considered as a kind of computer peripheral, because the connection to computer is necessary for typical use. It has been verified to comply with the requirements of FCC Part 15, Subpart B, Class B (DoC). The test report has been issued separately.

## 4. TEST TYPES AND RESULTS (FOR 2.4GHz BAND)

### 4.1 RADIATED EMISSION AND BANDEDGE MEASUREMENT

#### 4.1.1 LIMITS OF RADIATED EMISSION AND BANDEDGE MEASUREMENT

Radiated emissions which fall in the restricted bands must comply with the radiated emission limits specified as below table. Other emissions shall be at least 20dB below the highest level of the desired power:

FREQUENCIES (MHz)	FIELD STRENGTH (microvolts/meter)	MEASUREMENT DISTANCE (meters)
0.009 ~ 0.490	2400/F(kHz)	300
0.490 ~ 1.705	24000/F(kHz)	30
1.705 ~ 30.0	30	30
30 ~ 88	100	3
88 ~ 216	150	3
216 ~ 960	200	3
Above 960	500	3

**NOTE:**

1. The lower limit shall apply at the transition frequencies.
2. Emission level (dBuV/m) = 20 log Emission level (uV/m).
3. For frequencies above 1000MHz, the field strength limits are based on average detector, however, the peak field strength of any emission shall not exceed the maximum permitted average limits, specified above by more than 20dB under any condition of modulation.



A D T

**4.1.2 TEST INSTRUMENTS**

DESCRIPTION & MANUFACTURER	MODEL NO.	SERIAL NO.	DATE OF CALIBRATION	DUE DATE OF CALIBRATION
Test Receiver Rohde&Schwarz	ESCI	100744	Apr. 15, 2013	Apr. 14, 2014
			Apr. 15, 2014	Apr. 14, 2015
Spectrum Analyzer ROHDE & SCHWARZ	FSU43	101261	Dec. 21, 2013	Dec. 20, 2014
BILOG Antenna SCHWARZBECK	VULB9168	9168-472	Mar. 25, 2013	Mar. 24, 2014
			Feb. 27, 2014	Feb. 26, 2015
HORN Antenna SCHWARZBECK	BBHA 9120 D	9120D-405	Feb. 21, 2013	Feb. 20, 2014
			Mar. 03, 2014	Mar. 02, 2015
HORN Antenna SCHWARZBECK	BBHA 9170	9170-480	Dec. 18, 2013	Dec. 17, 2014
Preamplifier EMCI	EMC 012645	980115	Dec. 26, 2013	Dec. 25, 2014
Preamplifier EMCI	EMC 330H	980071	Dec. 27, 2013	Dec. 26, 2014
Preamplifier EMCI	EMC 330H	980112	Dec. 27, 2013	Dec. 26, 2014
RF signal cable HUBER+SUHNNER	SUCOFLEX 104	309219/4 2950114	Oct. 18, 2013	Oct. 17, 2014
RF signal cable HUBER+SUHNNER	SUCOFLEX 104	250130/4	Oct. 18, 2013	Oct. 17, 2014
RF signal cable Worken	RG-213	NA	Nov. 07, 2013	Nov. 06, 2014
Software BV ADT	E3 6.120103	NA	NA	NA
Antenna Tower MF	MFA-440H	NA	NA	NA
Turn Table MF	MFT-201SS	NA	NA	NA
Antenna Tower & Turn Table Controller MF	MF-7802	NA	NA	NA
Power Meter	ML2495A	1232002	Aug. 23, 2013	Aug. 22, 2014
Power Sensor	MA2411B	1207325	Aug. 23, 2013	Aug. 22, 2014

- NOTE:**
1. The calibration interval of the above test instruments is 12 months and the calibrations are traceable to NML/ROC and NIST/USA.
  2. The calibration interval of the loop antenna is 24 months and the calibrations are traceable to NML/ROC and NIST/USA.
  3. The test was performed in HwaYa Chamber 10.
  4. The horn antenna and HP preamplifier (model: 8449B) are used only for the measurement of emission frequency above 1GHz if tested.
  5. The FCC Site Registration No. is 690701.
  6. The IC Site Registration No. is IC 7450F-10.

#### 4.1.3 TEST PROCEDURES

- a. The EUT was placed on the top of a rotating table 0.8 meters above the ground at a 3 meters semi-anechoic chamber. The table was rotated 360 degrees to determine the position of the highest radiation.
- b. The EUT was set 3 meters away from the interference-receiving antenna, which was mounted on the top of a variable-height antenna tower.
- c. Height of receiving antenna is varied from one meter to four meters above the ground to determine the maximum value of the field strength. Both horizontal and vertical polarizations of the antenna are set to make the measurement.
- d. For each suspected emission, the EUT was arranged to its worst case and then the antenna was tuned to heights from 1 meter to 4 meters and the rotatable table was turned from 0 degrees to 360 degrees to find the maximum reading.
- e. The test-receiver system was set to Peak Detect Function and Specified Bandwidth with Maximum Hold Mode.
- f. If the emission level of the EUT in peak mode was lower than the limit specified, then testing could be stopped and the peak values of the EUT would be reported. Otherwise the emissions would be re-tested one by one using peak, quasi-peak or average method as specified and then reported in a data sheet.

**NOTE:**

1. The resolution bandwidth and video bandwidth of test receiver/spectrum analyzer is 120kHz for Quasi-peak detection at frequency below 1GHz.
2. The resolution bandwidth of test receiver/spectrum analyzer is 1MHz and video bandwidth is 3MHz for Peak detection at frequency above 1GHz.
3. The resolution bandwidth of test receiver/spectrum analyzer is 1MHz and the video bandwidth is 1kHz (Duty cycle < 98%) or 10Hz (Duty cycle > 98%) for Average detection (AV) at frequency above 1GHz.
4. All modes of operation were investigated and the worst-case emissions are reported.

#### 4.1.4 DEVIATION FROM TEST STANDARD

No deviation.

### 4.1.5 TEST SETUP

Frequency Range 30MHz ~ 1GHz

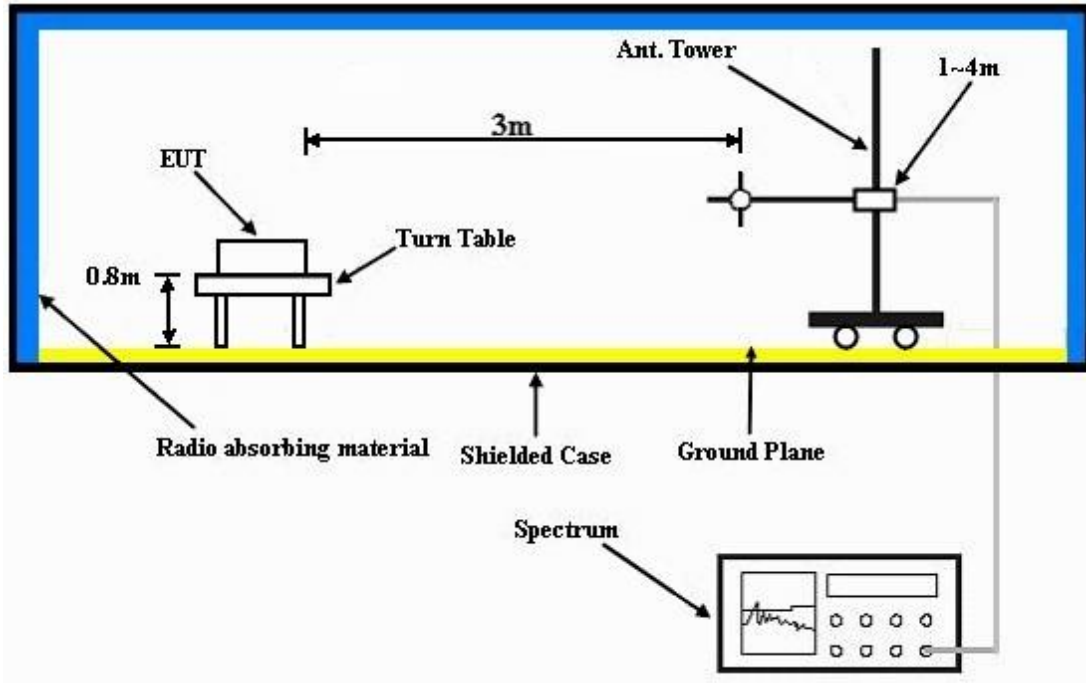

Frequency Range above 1GHz

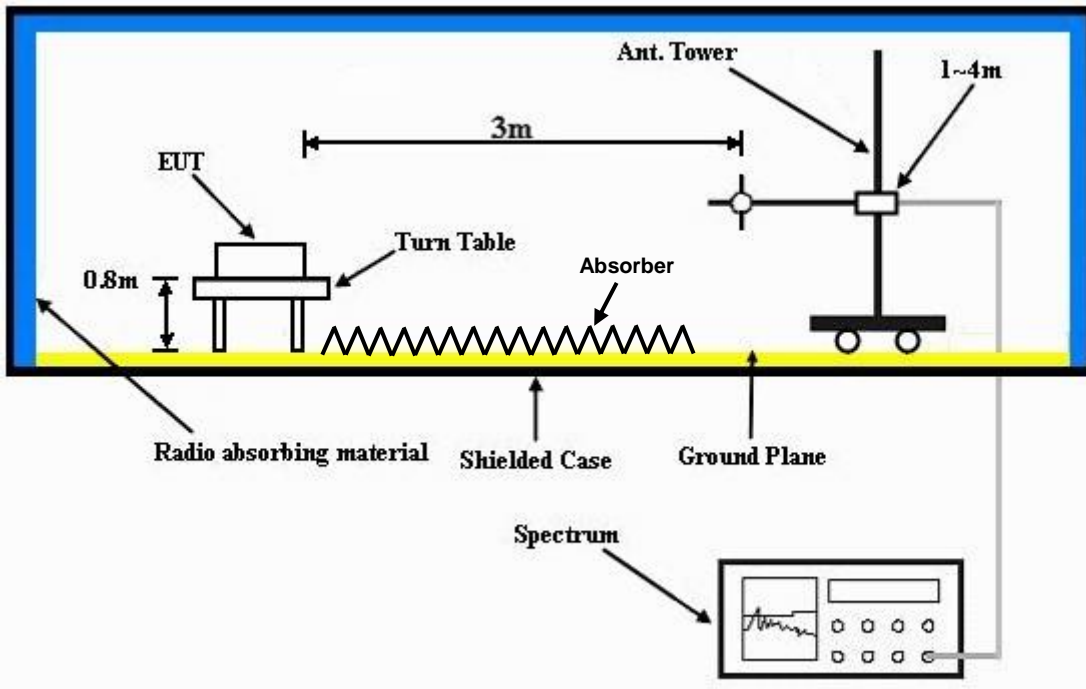

For the actual test configuration, please refer to the attached file (Test Setup Photo).



A D T

#### 4.1.6 EUT OPERATING CONDITIONS

- a. Placed the EUT on a testing table.
- b. Use the software to control the EUT under transmission condition continuously at specific channel frequency.



A D T

### 4.1.7 TEST RESULTS

#### MODE A

#### ABOVE 1GHz WORST-CASE DATA

#### 802.11b

EUT TEST CONDITION		MEASUREMENT DETAIL	
CHANNEL	Channel 1	FREQUENCY RANGE	1GHz ~ 25GHz
INPUT POWER	120Vac, 60 Hz	DETECTOR FUNCTION	Peak (PK) Average (AV)
ENVIRONMENTAL CONDITIONS	25deg. C, 65%RH	TESTED BY	Kay Wu

ANTENNA POLARITY & TEST DISTANCE: HORIZONTAL AT 3 M										
FREQ. (MHz)	EMISSION LEVEL (dBuV/m)	READ LEVEL (dBuV)	LIMIT (dBuV/m)	MARGIN (dB)	ANTENNA FACTOR (dB/m)	CABLE LOSS (dB)	PREAMP FACTOR (dB)	ANTENNA HEIGHT (cm)	TABLE ANGLE (Degree)	REMARK
2382	43.91	42.07	54	-10.09	31.93	5.4	35.49	146	52	Average
2382	56.38	54.54	74	-17.62	31.93	5.4	35.49	146	52	Peak
2412	96.9	94.98			31.96	5.43	35.47	146	52	Average
2412	99.13	97.21			31.96	5.43	35.47	146	52	Peak
2496	41.15	38.93	54	-12.85	32.1	5.53	35.41	146	52	Average
2496	56.65	54.43	74	-17.35	32.1	5.53	35.41	146	52	Peak
ANTENNA POLARITY & TEST DISTANCE: VERTICAL AT 3 M										
FREQ. (MHz)	EMISSION LEVEL (dBuV/m)	READ LEVEL (dBuV)	LIMIT (dBuV/m)	MARGIN (dB)	ANTENNA FACTOR (dB/m)	CABLE LOSS (dB)	PREAMP FACTOR (dB)	ANTENNA HEIGHT (cm)	TABLE ANGLE (Degree)	REMARK
2390	44.9	43.04	54	-9.1	31.93	5.4	35.47	150	279	Average
2390	57.97	56.11	74	-16.03	31.93	5.4	35.47	150	279	Peak
2412	101.75	99.83			31.96	5.43	35.47	150	279	Average
2412	103.98	102.06			31.96	5.43	35.47	150	279	Peak
2496	52.91	50.69	54	-1.09	32.1	5.53	35.41	150	279	Average
2496	61.41	59.19	74	-12.59	32.1	5.53	35.41	150	279	Peak

#### REMARKS:

- Emission Level = Read Level + Antenna Factor + Cable Loss - Preamp Factor  
Margin value = Emission level – Limit value
- 2412MHz: Fundamental frequency.



A D T

EUT TEST CONDITION		MEASUREMENT DETAIL	
CHANNEL	Channel 6	FREQUENCY RANGE	1GHz ~ 25GHz
INPUT POWER	120Vac, 60 Hz	DETECTOR FUNCTION	Peak (PK) Average (AV)
ENVIRONMENTAL CONDITIONS	25deg. C, 65%RH	TESTED BY	Kay Wu

**ANTENNA POLARITY & TEST DISTANCE: HORIZONTAL AT 3 M**

FREQ. (MHz)	EMISSION LEVEL (dBuV/m)	READ LEVEL (dBuV)	LIMIT (dBuV/m)	MARGIN (dB)	ANTENNA FACTOR (dB/m)	CABLE LOSS (dB)	PREAMP FACTOR (dB)	ANTENNA HEIGHT (cm)	TABLE ANGLE (Degree)	REMARK
2354	48.73	47.03	54	-5.27	31.87	5.33	35.5	105	58	Average
2354	57.54	55.84	74	-16.46	31.87	5.33	35.5	105	58	Peak
2437	104.57	102.56			32.01	5.46	35.46	105	58	Average
2437	106.83	104.82			32.01	5.46	35.46	105	58	Peak
2488	44.19	41.98	54	-9.81	32.1	5.53	35.42	105	58	Average
2488	56.74	54.53	74	-17.26	32.1	5.53	35.42	105	58	Peak

**ANTENNA POLARITY & TEST DISTANCE: VERTICAL AT 3 M**

FREQ. (MHz)	EMISSION LEVEL (dBuV/m)	READ LEVEL (dBuV)	LIMIT (dBuV/m)	MARGIN (dB)	ANTENNA FACTOR (dB/m)	CABLE LOSS (dB)	PREAMP FACTOR (dB)	ANTENNA HEIGHT (cm)	TABLE ANGLE (Degree)	REMARK
2354	50.89	49.19	54	-3.11	31.87	5.33	35.5	116	274	Average
2354	57.93	56.23	74	-16.07	31.87	5.33	35.5	116	274	Peak
2437	110.36	108.35			32.01	5.46	35.46	116	274	Average
2437	112.6	110.59			32.01	5.46	35.46	116	274	Peak
2484	51.82	49.64	54	-2.18	32.1	5.5	35.42	116	274	Average
2484	61.55	59.37	74	-12.45	32.1	5.5	35.42	116	274	Peak

**REMARKS:**

- Emission Level = Read Level + Antenna Factor + Cable Loss - Preamp Factor  
Margin value = Emission level – Limit value
- 2437MHz: Fundamental frequency.





A D T

EUT TEST CONDITION		MEASUREMENT DETAIL	
CHANNEL	Channel 11	FREQUENCY RANGE	1GHz ~ 25GHz
INPUT POWER	120Vac, 60 Hz	DETECTOR FUNCTION	Peak (PK) Average (AV)
ENVIRONMENTAL CONDITIONS	25deg. C, 65%RH	TESTED BY	Kay Wu

**ANTENNA POLARITY & TEST DISTANCE: HORIZONTAL AT 3 M**

FREQ. (MHz)	EMISSION LEVEL (dBuV/m)	READ LEVEL (dBuV)	LIMIT (dBuV/m)	MARGIN (dB)	ANTENNA FACTOR (dB/m)	CABLE LOSS (dB)	PREAMP FACTOR (dB)	ANTENNA HEIGHT (cm)	TABLE ANGLE (Degree)	REMARK
2386	44.85	43.01	54	-9.15	31.93	5.4	35.49	137	51	Average
2386	56.88	55.04	74	-17.12	31.93	5.4	35.49	137	51	Peak
2462	103.33	101.23			32.04	5.5	35.44	137	51	Average
2462	105.86	103.76			32.04	5.5	35.44	137	51	Peak
2486	45.22	43.01	54	-8.78	32.1	5.53	35.42	137	51	Average
2486	56.58	54.37	74	-17.42	32.1	5.53	35.42	137	51	Peak

**ANTENNA POLARITY & TEST DISTANCE: VERTICAL AT 3 M**

FREQ. (MHz)	EMISSION LEVEL (dBuV/m)	READ LEVEL (dBuV)	LIMIT (dBuV/m)	MARGIN (dB)	ANTENNA FACTOR (dB/m)	CABLE LOSS (dB)	PREAMP FACTOR (dB)	ANTENNA HEIGHT (cm)	TABLE ANGLE (Degree)	REMARK
2372	50.75	48.97	54	-3.25	31.9	5.37	35.49	151	268	Average
2372	58.15	56.37	74	-15.85	31.9	5.37	35.49	151	268	Peak
2462	109.46	107.36			32.04	5.5	35.44	151	268	Average
2462	111.37	109.27			32.04	5.5	35.44	151	268	Peak
2483.5	52.73	50.58	54	-1.27	32.07	5.5	35.42	151	268	Average
2483.5	61.29	59.14	74	-12.71	32.07	5.5	35.42	151	268	Peak

**REMARKS:**

- Emission Level = Read Level + Antenna Factor + Cable Loss - Preamp Factor  
Margin value = Emission level – Limit value
- 2462MHz: Fundamental frequency.



A D T

802.11g

EUT TEST CONDITION		MEASUREMENT DETAIL	
CHANNEL	Channel 1	FREQUENCY RANGE	1GHz ~ 25GHz
INPUT POWER	120Vac, 60 Hz	DETECTOR FUNCTION	Peak (PK) Average (AV)
ENVIRONMENTAL CONDITIONS	25deg. C, 65%RH	TESTED BY	Kay Wu

ANTENNA POLARITY & TEST DISTANCE: HORIZONTAL AT 3 M										
FREQ. (MHz)	EMISSION LEVEL (dBuV/m)	READ LEVEL (dBuV)	LIMIT (dBuV/m)	MARGIN (dB)	ANTENNA FACTOR (dB/m)	CABLE LOSS (dB)	PREAMP FACTOR (dB)	ANTENNA HEIGHT (cm)	TABLE ANGLE (Degree)	REMARK
2384	45.74	44.05	54	-8.26	31.78	5.4	35.49	170	278	Average
2384	54.89	53.2	74	-19.11	31.78	5.4	35.49	170	278	Peak
2412	92.81	91.04			31.81	5.43	35.47	170	278	Average
2412	100.6	98.83			31.81	5.43	35.47	170	278	Peak
2490	50	47.99	54	-4	31.9	5.53	35.42	170	278	Average
2490	57.17	55.16	74	-16.83	31.9	5.53	35.42	170	278	Peak
ANTENNA POLARITY & TEST DISTANCE: VERTICAL AT 3 M										
FREQ. (MHz)	EMISSION LEVEL (dBuV/m)	READ LEVEL (dBuV)	LIMIT (dBuV/m)	MARGIN (dB)	ANTENNA FACTOR (dB/m)	CABLE LOSS (dB)	PREAMP FACTOR (dB)	ANTENNA HEIGHT (cm)	TABLE ANGLE (Degree)	REMARK
2390	46.97	45.24	54	-7.03	31.8	5.4	35.47	108	11	Average
2390	56.29	54.56	74	-17.71	31.8	5.4	35.47	108	11	Peak
2412	99.77	98			31.81	5.43	35.47	108	11	Average
2412	107.99	106.22			31.81	5.43	35.47	108	11	Peak
2496	51.96	49.94	54	-2.04	31.9	5.53	35.41	108	11	Average
2496	59.68	57.66	74	-14.32	31.9	5.53	35.41	108	11	Peak

REMARKS:

- Emission Level = Read Level + Antenna Factor + Cable Loss - Preamp Factor  
Margin value = Emission level – Limit value
- 2412MHz: Fundamental frequency.



A D T

EUT TEST CONDITION		MEASUREMENT DETAIL	
CHANNEL	Channel 6	FREQUENCY RANGE	1GHz ~ 25GHz
INPUT POWER	120Vac, 60 Hz	DETECTOR FUNCTION	Peak (PK) Average (AV)
ENVIRONMENTAL CONDITIONS	25deg. C, 65%RH	TESTED BY	Kay Wu

**ANTENNA POLARITY & TEST DISTANCE: HORIZONTAL AT 3 M**

FREQ. (MHz)	EMISSION LEVEL (dBuV/m)	READ LEVEL (dBuV)	LIMIT (dBuV/m)	MARGIN (dB)	ANTENNA FACTOR (dB/m)	CABLE LOSS (dB)	PREAMP FACTOR (dB)	ANTENNA HEIGHT (cm)	TABLE ANGLE (Degree)	REMARK
2388	45.06	43.35	54	-8.94	31.8	5.4	35.49	170	278	Average
2388	55.76	54.05	74	-18.24	31.8	5.4	35.49	170	278	Peak
2437	96.88	95.03			31.85	5.46	35.46	170	278	Average
2437	103.6	101.75			31.85	5.46	35.46	170	278	Peak
2492	47.43	45.41	54	-6.57	31.9	5.53	35.41	170	278	Average
2492	56.89	54.87	74	-17.11	31.9	5.53	35.41	170	278	Peak

**ANTENNA POLARITY & TEST DISTANCE: VERTICAL AT 3 M**

FREQ. (MHz)	EMISSION LEVEL (dBuV/m)	READ LEVEL (dBuV)	LIMIT (dBuV/m)	MARGIN (dB)	ANTENNA FACTOR (dB/m)	CABLE LOSS (dB)	PREAMP FACTOR (dB)	ANTENNA HEIGHT (cm)	TABLE ANGLE (Degree)	REMARK
2390	47.09	45.36	54	-6.91	31.8	5.4	35.47	107	10	Average
2390	57.38	55.65	74	-16.62	31.8	5.4	35.47	107	10	Peak
2437	102.88	101.03			31.85	5.46	35.46	107	10	Average
2437	110.52	108.67			31.85	5.46	35.46	107	10	Peak
2486	51.31	49.32	54	-2.69	31.88	5.53	35.42	107	10	Average
2486	61	59.01	74	-13	31.88	5.53	35.42	107	10	Peak

**REMARKS:**

- Emission Level = Read Level + Antenna Factor + Cable Loss - Preamp Factor  
Margin value = Emission level – Limit value
- 2437MHz: Fundamental frequency.



A D T

EUT TEST CONDITION		MEASUREMENT DETAIL	
CHANNEL	Channel 11	FREQUENCY RANGE	1GHz ~ 25GHz
INPUT POWER	120Vac, 60 Hz	DETECTOR FUNCTION	Peak (PK) Average (AV)
ENVIRONMENTAL CONDITIONS	25deg. C, 65%RH	TESTED BY	Kay Wu

**ANTENNA POLARITY & TEST DISTANCE: HORIZONTAL AT 3 M**

FREQ. (MHz)	EMISSION LEVEL (dBuV/m)	READ LEVEL (dBuV)	LIMIT (dBuV/m)	MARGIN (dB)	ANTENNA FACTOR (dB/m)	CABLE LOSS (dB)	PREAMP FACTOR (dB)	ANTENNA HEIGHT (cm)	TABLE ANGLE (Degree)	REMARK
2342	44.64	43.07	54	-9.36	31.74	5.33	35.5	170	278	Average
2342	54.77	53.2	74	-19.23	31.74	5.33	35.5	170	278	Peak
2462	94.05	92.12			31.87	5.5	35.44	170	278	Average
2462	101.49	99.56			31.87	5.5	35.44	170	278	Peak
2483.5	49.61	47.65	54	-4.39	31.88	5.5	35.42	170	278	Average
2483.5	56.23	54.27	74	-17.77	31.88	5.5	35.42	170	278	Peak

**ANTENNA POLARITY & TEST DISTANCE: VERTICAL AT 3 M**

FREQ. (MHz)	EMISSION LEVEL (dBuV/m)	READ LEVEL (dBuV)	LIMIT (dBuV/m)	MARGIN (dB)	ANTENNA FACTOR (dB/m)	CABLE LOSS (dB)	PREAMP FACTOR (dB)	ANTENNA HEIGHT (cm)	TABLE ANGLE (Degree)	REMARK
2374	43.74	42.08	54	-10.26	31.78	5.37	35.49	107	10	Average
2374	55.85	54.19	74	-18.15	31.78	5.37	35.49	107	10	Peak
2462	99.6	97.67			31.87	5.5	35.44	107	10	Average
2462	107.07	105.14			31.87	5.5	35.44	107	10	Peak
2483.5	51.95	49.99	54	-2.05	31.88	5.5	35.42	107	10	Average
2483.5	58.87	56.91	74	-15.13	31.88	5.5	35.42	107	10	Peak

**REMARKS:**

- Emission Level = Read Level + Antenna Factor + Cable Loss - Preamp Factor  
Margin value = Emission level – Limit value
- 2462MHz: Fundamental frequency.



A D T

**802.11n (20MHz)**

EUT TEST CONDITION		MEASUREMENT DETAIL	
CHANNEL	Channel 1	FREQUENCY RANGE	1GHz ~ 25GHz
INPUT POWER	120Vac, 60 Hz	DETECTOR FUNCTION	Peak (PK) Average (AV)
ENVIRONMENTAL CONDITIONS	25deg. C, 65%RH	TESTED BY	Kay Wu

**ANTENNA POLARITY & TEST DISTANCE: HORIZONTAL AT 3 M**

FREQ. (MHz)	EMISSION LEVEL (dBuV/m)	READ LEVEL (dBuV)	LIMIT (dBuV/m)	MARGIN (dB)	ANTENNA FACTOR (dB/m)	CABLE LOSS (dB)	PREAMP FACTOR (dB)	ANTENNA HEIGHT (cm)	TABLE ANGLE (Degree)	REMARK
2310	46.67	45.19	54	-7.33	31.71	5.3	35.53	170	278	Average
2310	56.59	55.11	74	-17.41	31.71	5.3	35.53	170	278	Peak
2412	91.93	90.16			31.81	5.43	35.47	170	278	Average
2412	99.15	97.38			31.81	5.43	35.47	170	278	Peak
2498	47.99	45.97	54	-6.01	31.9	5.53	35.41	170	278	Average
2498	57.26	55.24	74	-16.74	31.9	5.53	35.41	170	278	Peak

**ANTENNA POLARITY & TEST DISTANCE: VERTICAL AT 3 M**

FREQ. (MHz)	EMISSION LEVEL (dBuV/m)	READ LEVEL (dBuV)	LIMIT (dBuV/m)	MARGIN (dB)	ANTENNA FACTOR (dB/m)	CABLE LOSS (dB)	PREAMP FACTOR (dB)	ANTENNA HEIGHT (cm)	TABLE ANGLE (Degree)	REMARK
2390	47.05	45.32	54	-6.95	31.8	5.4	35.47	107	10	Average
2390	58.34	56.61	74	-15.66	31.8	5.4	35.47	107	10	Peak
2412	98.77	97			31.81	5.43	35.47	107	10	Average
2412	106.38	104.61			31.81	5.43	35.47	107	10	Peak
2492	52	49.98	54	-2	31.9	5.53	35.41	107	10	Average
2492	60.76	58.74	74	-13.24	31.9	5.53	35.41	107	10	Peak

**REMARKS:**

- Emission Level = Read Level + Antenna Factor + Cable Loss - Preamp Factor  
Margin value = Emission level – Limit value
- 2412MHz: Fundamental frequency.



A D T

EUT TEST CONDITION		MEASUREMENT DETAIL	
CHANNEL	Channel 6	FREQUENCY RANGE	1GHz ~ 25GHz
INPUT POWER	120Vac, 60 Hz	DETECTOR FUNCTION	Peak (PK) Average (AV)
ENVIRONMENTAL CONDITIONS	25deg. C, 65%RH	TESTED BY	Kay Wu

**ANTENNA POLARITY & TEST DISTANCE: HORIZONTAL AT 3 M**

FREQ. (MHz)	EMISSION LEVEL (dBuV/m)	READ LEVEL (dBuV)	LIMIT (dBuV/m)	MARGIN (dB)	ANTENNA FACTOR (dB/m)	CABLE LOSS (dB)	PREAMP FACTOR (dB)	ANTENNA HEIGHT (cm)	TABLE ANGLE (Degree)	REMARK
2364	44.69	43.06	54	-9.31	31.76	5.37	35.5	170	278	Average
2364	55.21	53.58	74	-18.79	31.76	5.37	35.5	170	278	Peak
2437	93.88	92.03			31.85	5.46	35.46	170	278	Average
2437	101.31	99.46			31.85	5.46	35.46	170	278	Peak
2494	47.09	45.07	54	-6.91	31.9	5.53	35.41	170	278	Average
2494	56.72	54.7	74	-17.28	31.9	5.53	35.41	170	278	Peak

**ANTENNA POLARITY & TEST DISTANCE: VERTICAL AT 3 M**

FREQ. (MHz)	EMISSION LEVEL (dBuV/m)	READ LEVEL (dBuV)	LIMIT (dBuV/m)	MARGIN (dB)	ANTENNA FACTOR (dB/m)	CABLE LOSS (dB)	PREAMP FACTOR (dB)	ANTENNA HEIGHT (cm)	TABLE ANGLE (Degree)	REMARK
2372	45.04	43.38	54	-8.96	31.78	5.37	35.49	107	10	Average
2372	56.39	54.73	74	-17.61	31.78	5.37	35.49	107	10	Peak
2437	99.88	98.03			31.85	5.46	35.46	107	10	Average
2437	107.5	105.65			31.85	5.46	35.46	107	10	Peak
2483.5	50.91	48.95	54	-3.09	31.88	5.5	35.42	107	10	Average
2483.5	57.72	55.76	74	-16.28	31.88	5.5	35.42	107	10	Peak

**REMARKS:**

- Emission Level = Read Level + Antenna Factor + Cable Loss - Preamp Factor  
Margin value = Emission level – Limit value
- 2437MHz: Fundamental frequency.



A D T

EUT TEST CONDITION		MEASUREMENT DETAIL	
CHANNEL	Channel 11	FREQUENCY RANGE	1GHz ~ 25GHz
INPUT POWER	120Vac, 60 Hz	DETECTOR FUNCTION	Peak (PK) Average (AV)
ENVIRONMENTAL CONDITIONS	25deg. C, 65%RH	TESTED BY	Kay Wu

**ANTENNA POLARITY & TEST DISTANCE: HORIZONTAL AT 3 M**

FREQ. (MHz)	EMISSION LEVEL (dBuV/m)	READ LEVEL (dBuV)	LIMIT (dBuV/m)	MARGIN (dB)	ANTENNA FACTOR (dB/m)	CABLE LOSS (dB)	PREAMP FACTOR (dB)	ANTENNA HEIGHT (cm)	TABLE ANGLE (Degree)	REMARK
2374	44.71	43.05	54	-9.29	31.78	5.37	35.49	169	278	Average
2374	55.35	53.69	74	-18.65	31.78	5.37	35.49	169	278	Peak
2462	93.93	92			31.87	5.5	35.44	169	278	Average
2462	100.95	99.02			31.87	5.5	35.44	169	278	Peak
2488	46	43.99	54	-8	31.9	5.53	35.42	169	278	Average
2488	55.51	53.5	74	-18.49	31.9	5.53	35.42	169	278	Peak

**ANTENNA POLARITY & TEST DISTANCE: VERTICAL AT 3 M**

FREQ. (MHz)	EMISSION LEVEL (dBuV/m)	READ LEVEL (dBuV)	LIMIT (dBuV/m)	MARGIN (dB)	ANTENNA FACTOR (dB/m)	CABLE LOSS (dB)	PREAMP FACTOR (dB)	ANTENNA HEIGHT (cm)	TABLE ANGLE (Degree)	REMARK
2382	45.4	43.71	54	-8.6	31.78	5.4	35.49	107	10	Average
2382	55.92	54.23	74	-18.08	31.78	5.4	35.49	107	10	Peak
2462	98.93	97			31.87	5.5	35.44	107	10	Average
2462	106.73	104.8			31.87	5.5	35.44	107	10	Peak
2483.5	52.28	50.32	54	-1.72	31.88	5.5	35.42	107	10	Average
2483.5	59.71	57.75	74	-14.29	31.88	5.5	35.42	107	10	Peak

**REMARKS:**

- Emission Level = Read Level + Antenna Factor + Cable Loss - Preamp Factor  
Margin value = Emission level – Limit value
- 2462MHz: Fundamental frequency.



A D T

## 802.11n (40MHz)

EUT TEST CONDITION		MEASUREMENT DETAIL	
CHANNEL	Channel 3	FREQUENCY RANGE	1GHz ~ 25GHz
INPUT POWER	120Vac, 60 Hz	DETECTOR FUNCTION	Peak (PK) Average (AV)
ENVIRONMENTAL CONDITIONS	25deg. C, 65%RH	TESTED BY	Kay Wu

ANTENNA POLARITY & TEST DISTANCE: HORIZONTAL AT 3 M										
FREQ. (MHz)	EMISSION LEVEL (dBuV/m)	READ LEVEL (dBuV)	LIMIT (dBuV/m)	MARGIN (dB)	ANTENNA FACTOR (dB/m)	CABLE LOSS (dB)	PREAMP FACTOR (dB)	ANTENNA HEIGHT (cm)	TABLE ANGLE (Degree)	REMARK
2388	46.76	45.05	54	-7.24	31.8	5.4	35.49	170	278	Average
2388	54.92	53.21	74	-19.08	31.8	5.4	35.49	170	278	Peak
2422	92.83	91.03			31.83	5.43	35.46	170	278	Average
2422	99.61	97.81			31.83	5.43	35.46	170	278	Peak
2486	47.94	45.95	54	-6.06	31.88	5.53	35.42	170	278	Average
2486	55.62	53.63	74	-18.38	31.88	5.53	35.42	170	278	Peak

ANTENNA POLARITY & TEST DISTANCE: VERTICAL AT 3 M										
FREQ. (MHz)	EMISSION LEVEL (dBuV/m)	READ LEVEL (dBuV)	LIMIT (dBuV/m)	MARGIN (dB)	ANTENNA FACTOR (dB/m)	CABLE LOSS (dB)	PREAMP FACTOR (dB)	ANTENNA HEIGHT (cm)	TABLE ANGLE (Degree)	REMARK
2390	51.06	49.33	54	-2.94	31.8	5.4	35.47	107	10	Average
2390	60.38	58.65	74	-13.62	31.8	5.4	35.47	107	10	Peak
2422	97.82	96.02			31.83	5.43	35.46	107	10	Average
2422	105.27	103.47			31.83	5.43	35.46	107	10	Peak
2498	50.67	48.65	54	-3.33	31.9	5.53	35.41	107	10	Average
2498	59.04	57.02	74	-14.96	31.9	5.53	35.41	107	10	Peak

## REMARKS:

- Emission Level = Read Level + Antenna Factor + Cable Loss - Preamp Factor  
Margin value = Emission level – Limit value
- 2422MHz: Fundamental frequency.





A D T

EUT TEST CONDITION		MEASUREMENT DETAIL	
CHANNEL	Channel 6	FREQUENCY RANGE	1GHz ~ 25GHz
INPUT POWER	120Vac, 60 Hz	DETECTOR FUNCTION	Peak (PK) Average (AV)
ENVIRONMENTAL CONDITIONS	25deg. C, 65%RH	TESTED BY	Kay Wu

**ANTENNA POLARITY & TEST DISTANCE: HORIZONTAL AT 3 M**

FREQ. (MHz)	EMISSION LEVEL (dBuV/m)	READ LEVEL (dBuV)	LIMIT (dBuV/m)	MARGIN (dB)	ANTENNA FACTOR (dB/m)	CABLE LOSS (dB)	PREAMP FACTOR (dB)	ANTENNA HEIGHT (cm)	TABLE ANGLE (Degree)	REMARK
2342	44.94	43.37	54	-9.06	31.74	5.33	35.5	170	278	Average
2342	55.44	53.87	74	-18.56	31.74	5.33	35.5	170	278	Peak
2437	94.17	92.32			31.85	5.46	35.46	170	278	Average
2437	101.62	99.77			31.85	5.46	35.46	170	278	Peak
2484	49.5	47.54	54	-4.5	31.88	5.5	35.42	170	278	Average
2484	57.62	55.66	74	-16.38	31.88	5.5	35.42	170	278	Peak

**ANTENNA POLARITY & TEST DISTANCE: VERTICAL AT 3 M**

FREQ. (MHz)	EMISSION LEVEL (dBuV/m)	READ LEVEL (dBuV)	LIMIT (dBuV/m)	MARGIN (dB)	ANTENNA FACTOR (dB/m)	CABLE LOSS (dB)	PREAMP FACTOR (dB)	ANTENNA HEIGHT (cm)	TABLE ANGLE (Degree)	REMARK
2382	46.75	45.06	54	-7.25	31.78	5.4	35.49	107	10	Average
2382	57.72	56.03	74	-16.28	31.78	5.4	35.49	107	10	Peak
2437	100.88	99.03			31.85	5.46	35.46	107	10	Average
2437	108.53	106.68			31.85	5.46	35.46	107	10	Peak
2484	51.41	49.45	54	-2.59	31.88	5.5	35.42	107	10	Average
2484	60.52	58.56	74	-13.48	31.88	5.5	35.42	107	10	Peak

**REMARKS:**

- Emission Level = Read Level + Antenna Factor + Cable Loss - Preamp Factor  
Margin value = Emission level – Limit value
- 2437MHz: Fundamental frequency.



A D T

EUT TEST CONDITION		MEASUREMENT DETAIL	
CHANNEL	Channel 9	FREQUENCY RANGE	1GHz ~ 25GHz
INPUT POWER	120Vac, 60 Hz	DETECTOR FUNCTION	Peak (PK) Average (AV)
ENVIRONMENTAL CONDITIONS	25deg. C, 65%RH	TESTED BY	Kay Wu

**ANTENNA POLARITY & TEST DISTANCE: HORIZONTAL AT 3 M**

FREQ. (MHz)	EMISSION LEVEL (dBuV/m)	READ LEVEL (dBuV)	LIMIT (dBuV/m)	MARGIN (dB)	ANTENNA FACTOR (dB/m)	CABLE LOSS (dB)	PREAMP FACTOR (dB)	ANTENNA HEIGHT (cm)	TABLE ANGLE (Degree)	REMARK
2382	45.04	43.35	54	-8.96	31.78	5.4	35.49	170	278	Average
2382	54.96	53.27	74	-19.04	31.78	5.4	35.49	170	278	Peak
2452	91.88	90.01			31.85	5.46	35.44	170	278	Average
2452	99.75	97.88			31.85	5.46	35.44	170	278	Peak
2483.5	47.91	45.95	54	-6.09	31.88	5.5	35.42	170	278	Average
2483.5	56.97	55.01	74	-17.03	31.88	5.5	35.42	170	278	Peak

**ANTENNA POLARITY & TEST DISTANCE: VERTICAL AT 3 M**

FREQ. (MHz)	EMISSION LEVEL (dBuV/m)	READ LEVEL (dBuV)	LIMIT (dBuV/m)	MARGIN (dB)	ANTENNA FACTOR (dB/m)	CABLE LOSS (dB)	PREAMP FACTOR (dB)	ANTENNA HEIGHT (cm)	TABLE ANGLE (Degree)	REMARK
2378	45.71	44.05	54	-8.29	31.78	5.37	35.49	107	10	Average
2378	56.63	54.97	74	-17.37	31.78	5.37	35.49	107	10	Peak
2452	97.55	95.68			31.85	5.46	35.44	107	10	Average
2452	105.5	103.63			31.85	5.46	35.44	107	10	Peak
2483.5	51.95	49.99	54	-2.05	31.88	5.5	35.42	107	10	Average
2483.5	60.65	58.69	74	-13.35	31.88	5.5	35.42	107	10	Peak

**REMARKS:**

- Emission Level = Read Level + Antenna Factor + Cable Loss - Preamp Factor  
Margin value = Emission level – Limit value
- 2452MHz: Fundamental frequency.



A D T

**BELOW 1GHz WORST-CASE DATA:**

**802.11b**

EUT TEST CONDITION		MEASUREMENT DETAIL	
CHANNEL	Channel 1	FREQUENCY RANGE	30MHz ~ 1GHz
INPUT POWER	120Vac, 60 Hz	DETECTOR FUNCTION	Peak (PK)
ENVIRONMENTAL CONDITIONS	25deg. C, 65%RH	TESTED BY	Kay Wu

**ANTENNA POLARITY & TEST DISTANCE: HORIZONTAL AT 3 M**

FREQ. (MHz)	EMISSION LEVEL (dBuV/m)	READ LEVEL (dBuV)	LIMIT (dBuV/m)	MARGIN (dB)	ANTENNA FACTOR (dB/m)	CABLE LOSS (dB)	PREAMP FACTOR (dB)	ANTENNA HEIGHT (cm)	TABLE ANGLE (Degree)	REMARK
99.66	28.52	49.84	43.5	-14.98	9.66	1.28	32.26	155	215	Peak
166.62	25.26	45.7	43.5	-18.24	10.29	1.52	32.25	162	325	Peak
199.29	38.09	57.9	43.5	-5.41	10.84	1.65	32.3	157	205	Peak
314	37.33	52.66	46	-8.67	14.68	2.11	32.12	156	215	Peak
499.5	38.13	48.6	46	-7.87	19	2.63	32.1	163	332	Peak
700.4	29.21	35.09	46	-16.79	23.1	3.11	32.09	105	116	Peak

**ANTENNA POLARITY & TEST DISTANCE: VERTICAL AT 3 M**

FREQ. (MHz)	EMISSION LEVEL (dBuV/m)	READ LEVEL (dBuV)	LIMIT (dBuV/m)	MARGIN (dB)	ANTENNA FACTOR (dB/m)	CABLE LOSS (dB)	PREAMP FACTOR (dB)	ANTENNA HEIGHT (cm)	TABLE ANGLE (Degree)	REMARK
30.54	30.65	44.86	40	-9.35	17.31	0.74	32.26	155	125	Peak
99.93	23.3	44.62	43.5	-20.2	9.66	1.28	32.26	158	51	Peak
166.62	27.31	47.75	43.5	-16.19	10.29	1.52	32.25	165	216	Peak
327.3	33.05	47.75	46	-12.95	15.29	2.11	32.1	195	157	Peak
499.5	34.98	45.45	46	-11.02	19	2.63	32.1	165	226	Peak
778.8	31.28	36.42	46	-14.72	23.68	3.27	32.09	123	220	Peak

**REMARKS:** Emission Level = Read Level + Antenna Factor + Cable Loss - Preamp Factor

Margin value = Emission level – Limit value



A D T

**MODE C**

**802.11n (20MHz)**

EUT TEST CONDITION		MEASUREMENT DETAIL	
CHANNEL	Channel 1	FREQUENCY RANGE	1GHz ~ 25GHz
INPUT POWER	120Vac, 60 Hz	DETECTOR FUNCTION	Peak (PK) Average (AV)
ENVIRONMENTAL CONDITIONS	25deg. C, 65%RH	TESTED BY	Kay Wu

ANTENNA POLARITY & TEST DISTANCE: HORIZONTAL AT 3 M										
FREQ. (MHz)	EMISSION LEVEL (dBuV/m)	READ LEVEL (dBuV)	LIMIT (dBuV/m)	MARGIN (dB)	ANTENNA FACTOR (dB/m)	CABLE LOSS (dB)	PREAMP FACTOR (dB)	ANTENNA HEIGHT (cm)	TABLE ANGLE (Degree)	REMARK
2386	48.06	46.35	54	-5.94	31.8	5.4	35.49	183	236	Average
2386	58.41	56.7	74	-15.59	31.8	5.4	35.49	183	236	Peak
2412	100.77	99			31.81	5.43	35.47	183	236	Average
2412	107.28	105.51			31.81	5.43	35.47	183	236	Peak
2500	49.96	47.94	54	-4.04	31.9	5.53	35.41	183	236	Average
2500	59.49	57.47	74	-14.51	31.9	5.53	35.41	183	236	Peak

ANTENNA POLARITY & TEST DISTANCE: VERTICAL AT 3 M										
FREQ. (MHz)	EMISSION LEVEL (dBuV/m)	READ LEVEL (dBuV)	LIMIT (dBuV/m)	MARGIN (dB)	ANTENNA FACTOR (dB/m)	CABLE LOSS (dB)	PREAMP FACTOR (dB)	ANTENNA HEIGHT (cm)	TABLE ANGLE (Degree)	REMARK
2390	51.06	49.33	54	-2.94	31.8	5.4	35.47	109	22	Average
2390	60.57	58.84	74	-13.43	31.8	5.4	35.47	109	22	Peak
2412	102.77	101			31.81	5.43	35.47	107	360	Average
2412	109.77	108			31.81	5.43	35.47	107	360	Peak
2498	52.09	50.07	54	-1.91	31.9	5.53	35.41	104	359	Average
2498	62.97	60.95	74	-11.03	31.9	5.53	35.41	104	359	Peak

**REMARKS:**

- Emission Level = Read Level + Antenna Factor + Cable Loss - Preamp Factor  
Margin value = Emission level – Limit value
- 2412MHz: Fundamental frequency.



A D T

EUT TEST CONDITION		MEASUREMENT DETAIL	
CHANNEL	Channel 6	FREQUENCY RANGE	1GHz ~ 25GHz
INPUT POWER	120Vac, 60 Hz	DETECTOR FUNCTION	Peak (PK) Average (AV)
ENVIRONMENTAL CONDITIONS	25deg. C, 65%RH	TESTED BY	Kay Wu

**ANTENNA POLARITY & TEST DISTANCE: HORIZONTAL AT 3 M**

FREQ. (MHz)	EMISSION LEVEL (dBuV/m)	READ LEVEL (dBuV)	LIMIT (dBuV/m)	MARGIN (dB)	ANTENNA FACTOR (dB/m)	CABLE LOSS (dB)	PREAMP FACTOR (dB)	ANTENNA HEIGHT (cm)	TABLE ANGLE (Degree)	REMARK
2372	46.04	44.38	54	-7.96	31.78	5.37	35.49	183	236	Average
2372	57.05	55.39	74	-16.95	31.78	5.37	35.49	183	236	Peak
2437	100.55	98.7			31.85	5.46	35.46	183	236	Average
2437	107.52	105.67			31.85	5.46	35.46	183	236	Peak
2498	48	45.98	54	-6	31.9	5.53	35.41	183	236	Average
2498	56.66	54.64	74	-17.34	31.9	5.53	35.41	183	236	Peak

**ANTENNA POLARITY & TEST DISTANCE: VERTICAL AT 3 M**

FREQ. (MHz)	EMISSION LEVEL (dBuV/m)	READ LEVEL (dBuV)	LIMIT (dBuV/m)	MARGIN (dB)	ANTENNA FACTOR (dB/m)	CABLE LOSS (dB)	PREAMP FACTOR (dB)	ANTENNA HEIGHT (cm)	TABLE ANGLE (Degree)	REMARK
2344	47.98	46.41	54	-6.02	31.74	5.33	35.5	107	360	Average
2344	57.87	56.3	74	-16.13	31.74	5.33	35.5	107	360	Peak
2437	102.17	100.32			31.85	5.46	35.46	107	360	Average
2437	111.73	109.88			31.85	5.46	35.46	107	360	Peak
2492	51.96	49.94	54	-2.04	31.9	5.53	35.41	104	359	Average
2492	61.25	59.23	74	-12.75	31.9	5.53	35.41	104	359	Peak

**REMARKS:**

- Emission Level = Read Level + Antenna Factor + Cable Loss - Preamp Factor  
Margin value = Emission level – Limit value
- 2437MHz: Fundamental frequency.



A D T

EUT TEST CONDITION		MEASUREMENT DETAIL	
CHANNEL	Channel 11	FREQUENCY RANGE	1GHz ~ 25GHz
INPUT POWER	120Vac, 60 Hz	DETECTOR FUNCTION	Peak (PK) Average (AV)
ENVIRONMENTAL CONDITIONS	25deg. C, 65%RH	TESTED BY	Kay Wu

**ANTENNA POLARITY & TEST DISTANCE: HORIZONTAL AT 3 M**

FREQ. (MHz)	EMISSION LEVEL (dBuV/m)	READ LEVEL (dBuV)	LIMIT (dBuV/m)	MARGIN (dB)	ANTENNA FACTOR (dB/m)	CABLE LOSS (dB)	PREAMP FACTOR (dB)	ANTENNA HEIGHT (cm)	TABLE ANGLE (Degree)	REMARK
2380	48.67	47.01	54	-5.33	31.78	5.37	35.49	183	236	Average
2380	55.5	53.84	74	-18.5	31.78	5.37	35.49	183	236	Peak
2462	97.6	95.67			31.87	5.5	35.44	183	236	Average
2462	105.42	103.49			31.87	5.5	35.44	183	236	Peak
2483.5	47.62	45.66	54	-6.38	31.88	5.5	35.42	183	236	Average
2483.5	55.14	53.18	74	-18.86	31.88	5.5	35.42	183	236	Peak

**ANTENNA POLARITY & TEST DISTANCE: VERTICAL AT 3 M**

FREQ. (MHz)	EMISSION LEVEL (dBuV/m)	READ LEVEL (dBuV)	LIMIT (dBuV/m)	MARGIN (dB)	ANTENNA FACTOR (dB/m)	CABLE LOSS (dB)	PREAMP FACTOR (dB)	ANTENNA HEIGHT (cm)	TABLE ANGLE (Degree)	REMARK
2388	47.72	46.01	54	-6.28	31.8	5.4	35.49	107	360	Average
2388	57.11	55.4	74	-16.89	31.8	5.4	35.49	107	360	Peak
2462	102.22	100.29			31.87	5.5	35.44	107	360	Average
2462	110.17	108.24			31.87	5.5	35.44	107	360	Peak
2484	52.94	50.98	54	-1.06	31.88	5.5	35.42	104	359	Average
2484	63.11	61.15	74	-10.89	31.88	5.5	35.42	104	359	Peak

**REMARKS:**

- Emission Level = Read Level + Antenna Factor + Cable Loss - Preamp Factor  
Margin value = Emission level – Limit value
- 2462MHz: Fundamental frequency.



A D T

**802.11n (40MHz)**

EUT TEST CONDITION		MEASUREMENT DETAIL	
CHANNEL	Channel 3	FREQUENCY RANGE	1GHz ~ 25GHz
INPUT POWER	120Vac, 60 Hz	DETECTOR FUNCTION	Peak (PK) Average (AV)
ENVIRONMENTAL CONDITIONS	25deg. C, 65%RH	TESTED BY	Kay Wu

**ANTENNA POLARITY & TEST DISTANCE: HORIZONTAL AT 3 M**

FREQ. (MHz)	EMISSION LEVEL (dBuV/m)	READ LEVEL (dBuV)	LIMIT (dBuV/m)	MARGIN (dB)	ANTENNA FACTOR (dB/m)	CABLE LOSS (dB)	PREAMP FACTOR (dB)	ANTENNA HEIGHT (cm)	TABLE ANGLE (Degree)	REMARK
2390	48.72	46.99	54	-5.28	31.8	5.4	35.47	183	236	Average
2390	58.24	56.51	74	-15.76	31.8	5.4	35.47	183	236	Peak
2422	97.37	95.57			31.83	5.43	35.46	183	236	Average
2422	104.75	102.95			31.83	5.43	35.46	183	236	Peak
2496	47.67	45.65	54	-6.33	31.9	5.53	35.41	183	236	Average
2496	57.13	55.11	74	-16.87	31.9	5.53	35.41	183	236	Peak

**ANTENNA POLARITY & TEST DISTANCE: VERTICAL AT 3 M**

FREQ. (MHz)	EMISSION LEVEL (dBuV/m)	READ LEVEL (dBuV)	LIMIT (dBuV/m)	MARGIN (dB)	ANTENNA FACTOR (dB/m)	CABLE LOSS (dB)	PREAMP FACTOR (dB)	ANTENNA HEIGHT (cm)	TABLE ANGLE (Degree)	REMARK
2390	52.72	50.99	54	-1.28	31.8	5.4	35.47	108	14	Average
2390	62.57	60.84	74	-11.43	31.8	5.4	35.47	108	14	Peak
2422	101.49	99.69			31.83	5.43	35.46	107	360	Average
2422	109.16	107.36			31.83	5.43	35.46	107	360	Peak
2492	51	48.98	54	-3	31.9	5.53	35.41	107	360	Average
2492	61.11	59.09	74	-12.89	31.9	5.53	35.41	107	360	Peak

**REMARKS:**

- Emission Level = Read Level + Antenna Factor + Cable Loss - Preamp Factor  
Margin value = Emission level – Limit value
- 2422MHz: Fundamental frequency.



A D T

EUT TEST CONDITION		MEASUREMENT DETAIL	
CHANNEL	Channel 6	FREQUENCY RANGE	1GHz ~ 25GHz
INPUT POWER	120Vac, 60 Hz	DETECTOR FUNCTION	Peak (PK) Average (AV)
ENVIRONMENTAL CONDITIONS	25deg. C, 65%RH	TESTED BY	Kay Wu

**ANTENNA POLARITY & TEST DISTANCE: HORIZONTAL AT 3 M**

FREQ. (MHz)	EMISSION LEVEL (dBuV/m)	READ LEVEL (dBuV)	LIMIT (dBuV/m)	MARGIN (dB)	ANTENNA FACTOR (dB/m)	CABLE LOSS (dB)	PREAMP FACTOR (dB)	ANTENNA HEIGHT (cm)	TABLE ANGLE (Degree)	REMARK
2360	44.99	43.36	54	-9.01	31.76	5.37	35.5	183	236	Average
2360	56.79	55.16	74	-17.21	31.76	5.37	35.5	183	236	Peak
2437	97.55	95.7			31.85	5.46	35.46	183	236	Average
2437	105.81	103.96			31.85	5.46	35.46	183	236	Peak
2484	44.98	43.02	54	-9.02	31.88	5.5	35.42	183	236	Average
2484	57.06	55.1	74	-16.94	31.88	5.5	35.42	183	236	Peak

**ANTENNA POLARITY & TEST DISTANCE: VERTICAL AT 3 M**

FREQ. (MHz)	EMISSION LEVEL (dBuV/m)	READ LEVEL (dBuV)	LIMIT (dBuV/m)	MARGIN (dB)	ANTENNA FACTOR (dB/m)	CABLE LOSS (dB)	PREAMP FACTOR (dB)	ANTENNA HEIGHT (cm)	TABLE ANGLE (Degree)	REMARK
2380	46.71	45.05	54	-7.29	31.78	5.37	35.49	107	360	Average
2380	56.97	55.31	74	-17.03	31.78	5.37	35.49	107	360	Peak
2437	101.84	99.99			31.85	5.46	35.46	107	360	Average
2437	109.6	107.75			31.85	5.46	35.46	107	360	Peak
2496	51.65	49.63	54	-2.35	31.9	5.53	35.41	107	360	Average
2496	61.52	59.5	74	-12.48	31.9	5.53	35.41	107	360	Peak

**REMARKS:**

- Emission Level = Read Level + Antenna Factor + Cable Loss - Preamp Factor  
Margin value = Emission level – Limit value
- 2437MHz: Fundamental frequency.





A D T

EUT TEST CONDITION		MEASUREMENT DETAIL	
CHANNEL	Channel 9	FREQUENCY RANGE	1GHz ~ 25GHz
INPUT POWER	120Vac, 60 Hz	DETECTOR FUNCTION	Peak (PK) Average (AV)
ENVIRONMENTAL CONDITIONS	25deg. C, 65%RH	TESTED BY	Kay Wu

**ANTENNA POLARITY & TEST DISTANCE: HORIZONTAL AT 3 M**

FREQ. (MHz)	EMISSION LEVEL (dBuV/m)	READ LEVEL (dBuV)	LIMIT (dBuV/m)	MARGIN (dB)	ANTENNA FACTOR (dB/m)	CABLE LOSS (dB)	PREAMP FACTOR (dB)	ANTENNA HEIGHT (cm)	TABLE ANGLE (Degree)	REMARK
2384	46.29	44.6	54	-7.71	31.78	5.4	35.49	100	54	Average
2384	57.29	55.6	74	-16.71	31.78	5.4	35.49	100	54	Peak
2452	96.55	94.68			31.85	5.46	35.44	100	54	Average
2452	104.3	102.43			31.85	5.46	35.44	100	54	Peak
2484	48.08	46.12	54	-5.92	31.88	5.5	35.42	100	54	Average
2484	60.91	58.95	74	-13.09	31.88	5.5	35.42	100	54	Peak

**ANTENNA POLARITY & TEST DISTANCE: VERTICAL AT 3 M**

FREQ. (MHz)	EMISSION LEVEL (dBuV/m)	READ LEVEL (dBuV)	LIMIT (dBuV/m)	MARGIN (dB)	ANTENNA FACTOR (dB/m)	CABLE LOSS (dB)	PREAMP FACTOR (dB)	ANTENNA HEIGHT (cm)	TABLE ANGLE (Degree)	REMARK
2340	45.59	44.02	54	-8.41	31.74	5.33	35.5	107	359	Average
2340	57.86	56.29	74	-16.14	31.74	5.33	35.5	107	359	Peak
2452	101.79	99.92			31.85	5.46	35.44	107	359	Average
2452	110.16	108.29			31.85	5.46	35.44	107	359	Peak
2484	52.63	50.67	54	-1.37	31.88	5.5	35.42	107	359	Average
2484	66.64	64.68	74	-7.36	31.88	5.5	35.42	107	359	Peak

**REMARKS:**

- Emission Level = Read Level + Antenna Factor + Cable Loss - Preamp Factor  
Margin value = Emission level – Limit value
- 2452MHz: Fundamental frequency.

## 4.2 6dB BANDWIDTH MEASUREMENT

### 4.2.1 LIMITS OF 6dB BANDWIDTH MEASUREMENT

The minimum of 6dB Bandwidth Measurement is 0.5 MHz.

### 4.2.2 TEST SETUP

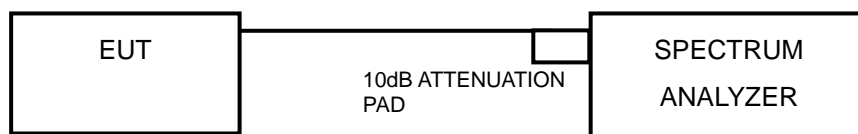

### 4.2.3 TEST INSTRUMENTS

Refer to section 4.1.2 to get information of above instrument.

### 4.2.4 TEST PROCEDURE

- a. Set resolution bandwidth (RBW) = 100kHz
- b. Set the video bandwidth (VBW)  $\geq 3 \times$  RBW, Detector = Peak.
- c. Trace mode = max hold.
- d. Sweep = auto couple.
- e. Measure the maximum width of the emission that is constrained by the frequencies associated with the two amplitude points (upper and lower) that are attenuated by 6 dB relative to the maximum level measured in the fundamental emission

### 4.2.5 DEVIATION FROM TEST STANDARD

No deviation.

### 4.2.6 EUT OPERATING CONDITIONS

The software provided by client to enable the EUT under transmission condition continuously at lowest, middle and highest channel frequencies individually.

#### 4.2.7 TEST RESULTS

##### MODE A

##### 802.11b

CHANNEL	FREQUENCY (MHz)	6dB BANDWIDTH (MHz)	MINIMUM LIMIT (MHz)	PASS / FAIL
1	2412	10.11	0.5	PASS
6	2437	10.11	0.5	PASS
11	2462	10.12	0.5	PASS

##### 802.11g

CHANNEL	FREQUENCY (MHz)	6dB BANDWIDTH (MHz)	MINIMUM LIMIT (MHz)	PASS / FAIL
1	2412	16.37	0.5	PASS
6	2437	16.38	0.5	PASS
11	2462	16.38	0.5	PASS

##### 802.11n (20MHz)

CHANNEL	FREQUENCY (MHz)	6dB BANDWIDTH (MHz)	MINIMUM LIMIT (MHz)	PASS / FAIL
1	2412	17.60	0.5	PASS
6	2437	17.60	0.5	PASS
11	2462	17.58	0.5	PASS

##### 802.11n (40MHz)

CHANNEL	FREQUENCY (MHz)	6dB BANDWIDTH (MHz)	MINIMUM LIMIT (MHz)	PASS / FAIL
3	2422	35.48	0.5	PASS
6	2437	35.25	0.5	PASS
9	2452	35.50	0.5	PASS



A D T

### MODE C

#### 802.11n (20MHz)

CHANNEL	FREQUENCY (MHz)	6dB BANDWIDTH (MHz)			MINIMUM LIMIT (MHz)	PASS / FAIL
		CHAIN 0	CHAIN 1	CHAIN 2		
1	2412	17.61	17.60	17.61	0.5	PASS
6	2437	17.38	17.62	17.61	0.5	PASS
11	2462	17.62	17.63	17.62	0.5	PASS

#### 802.11n (40MHz)

CHANNEL	FREQUENCY (MHz)	6dB BANDWIDTH (MHz)			MINIMUM LIMIT (MHz)	PASS / FAIL
		CHAIN 0	CHAIN 1	CHAIN 2		
3	2422	35.53	35.21	35.20	0.5	PASS
6	2437	35.40	35.25	35.27	0.5	PASS
9	2452	35.26	35.26	35.23	0.5	PASS



A D T

### SPECTRUM PLOT OF WORST VALUE

#### 802.11b

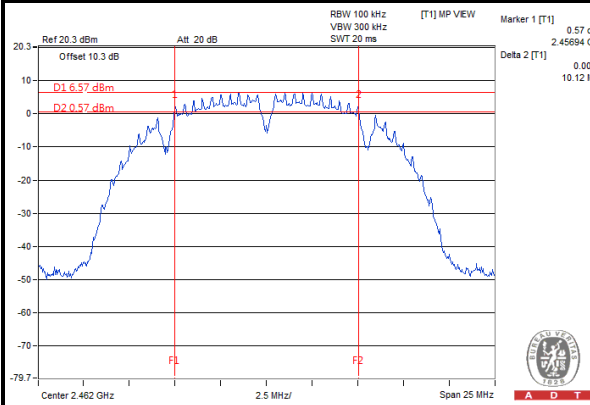

#### 802.11g

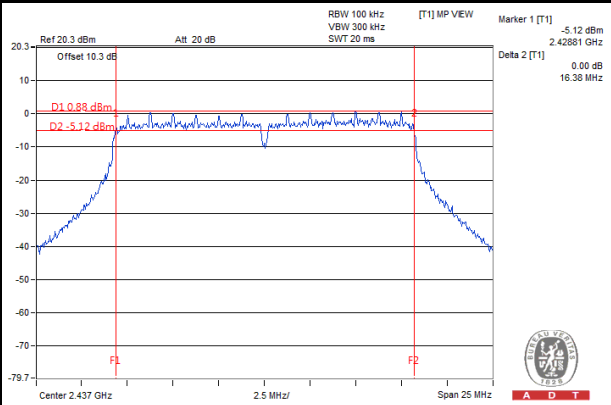

#### 802.11n (20MHz)

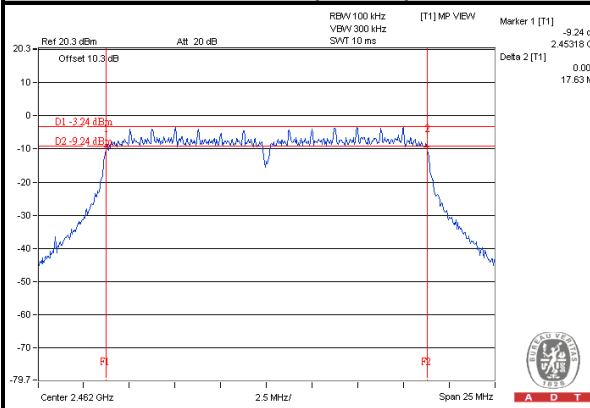

#### 802.11n (40MHz)

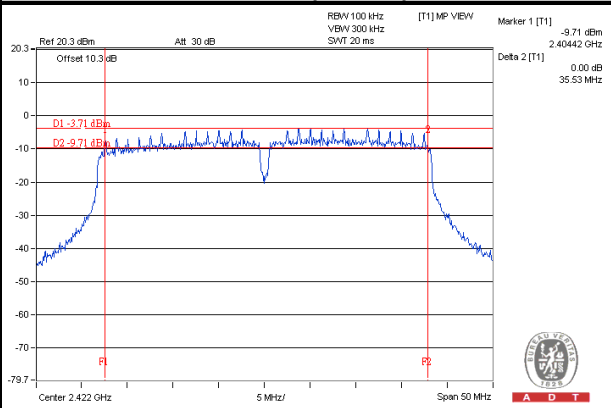

## 4.3 CONDUCTED OUTPUT POWER

### 4.3.1 LIMITS OF CONDUCTED OUTPUT POWER MEASUREMENT

For systems using digital modulation in the 2400–2483.5 MHz bands: 1 Watt (30dBm)

Per KDB 662911 D01 Multiple Transmitter Output v02r01 Method of conducted output power measurement on IEEE 802.11 devices,

Array Gain = 0 dB (i.e., no array gain) for  $NANT \leq 4$ ;

Array Gain = 0 dB (i.e., no array gain) for channel widths  $\geq 40$  MHz for any NANT;

Array Gain =  $5 \log(NANT/NSS)$  dB or 3 dB, whichever is less for 20-MHz channel widths with  $NANT \geq 5$ .

For power measurements on all other devices: Array Gain =  $10 \log(NANT/NSS)$  dB.

### 4.3.2 TEST SETUP

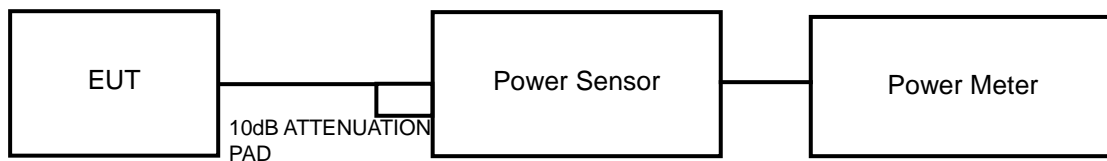

### 4.3.3 TEST INSTRUMENTS

Refer to section 4.1.2 to get information of above instrument.

### 4.3.4 TEST PROCEDURES

A peak power sensor was used on the output port of the EUT. A power meter was used to read the response of the peak power sensor. Record the peak power level.

### 4.3.5 DEVIATION FROM TEST STANDARD

No deviation.

### 4.3.6 EUT OPERATING CONDITIONS

Same as section 4.2.6.

### 4.3.7 TEST RESULTS

#### MODE A

##### 802.11b

CHANNEL	FREQUENCY (MHz)	PEAK POWER (mW)	PEAK POWER (dBm)	LIMIT (dBm)	PASS / FAIL
1	2412	14.29	11.55	30	PASS
6	2437	70.31	18.47	30	PASS
11	2462	59.98	17.78	30	PASS

##### 802.11g

CHANNEL	FREQUENCY (MHz)	PEAK POWER (mW)	PEAK POWER (dBm)	LIMIT (dBm)	PASS / FAIL
1	2412	62.81	17.98	30	PASS
6	2437	146.55	21.66	30	PASS
11	2462	78.52	18.95	30	PASS

##### 802.11n (20MHz)

CHANNEL	FREQUENCY (MHz)	PEAK POWER (mW)	PEAK POWER (dBm)	LIMIT (dBm)	PASS / FAIL
1	2412	61.94	17.92	30	PASS
6	2437	76.38	18.83	30	PASS
11	2462	67.14	18.27	30	PASS

##### 802.11n (40MHz)

CHANNEL	FREQUENCY (MHz)	PEAK POWER (mW)	PEAK POWER (dBm)	LIMIT (dBm)	PASS / FAIL
3	2422	68.87	18.38	30	PASS
6	2437	114.55	20.59	30	PASS
9	2452	78.89	18.97	30	PASS



A D T

### MODE B

#### 802.11n (20MHz)

CHAN.	FREQ. (MHz)	PEAK POWER (dBm)		TOTAL POWER (mW)	TOTAL POWER (dBm)	LIMIT (dBm)	PASS / FAIL
		CHAIN 0	CHAIN 1				
1	2412	18.46	18.18	135.911	21.33	30	PASS
6	2437	18.49	18.05	134.458	21.29	30	PASS
11	2462	18.27	18.19	133.060	21.24	30	PASS

#### 802.11n (40MHz)

CHAN.	FREQ. (MHz)	PEAK POWER (dBm)		TOTAL POWER (mW)	TOTAL POWER (dBm)	LIMIT (dBm)	PASS / FAIL
		CHAIN 0	CHAIN 1				
3	2422	18.64	17.71	132.134	21.21	30	PASS
6	2437	18.57	17.46	127.663	21.06	30	PASS
9	2452	18.86	17.33	130.988	21.17	30	PASS

### MODE C

#### 802.11n (20MHz)

CHAN.	FREQ. (MHz)	PEAK POWER (dBm)			TOTAL POWER (mW)	TOTAL POWER (dBm)	LIMIT (dBm)	PASS / FAIL
		CHAIN 0	CHAIN 1	CHAIN 2				
1	2412	17.35	17.53	17.47	166.796	22.22	30	PASS
6	2437	19.67	18.44	18.09	226.923	23.56	30	PASS
11	2462	18.64	17.58	17.51	186.757	22.71	30	PASS

#### 802.11n (40MHz)

CHAN.	FREQ. (MHz)	PEAK POWER (dBm)			TOTAL POWER (mW)	TOTAL POWER (dBm)	LIMIT (dBm)	PASS / FAIL
		CHAIN 0	CHAIN 1	CHAIN 2				
3	2422	18.39	16.98	16.84	167.218	22.23	30	PASS
6	2437	19.64	18.78	17.46	223.273	23.49	30	PASS
9	2452	18.54	16.98	16.75	168.653	22.27	30	PASS



## 4.4 POWER SPECTRAL DENSITY MEASUREMENT

### 4.4.1 LIMITS OF POWER SPECTRAL DENSITY MEASUREMENT

The Maximum of Power Spectral Density Measurement is 8dBm.

### 4.4.2 TEST SETUP

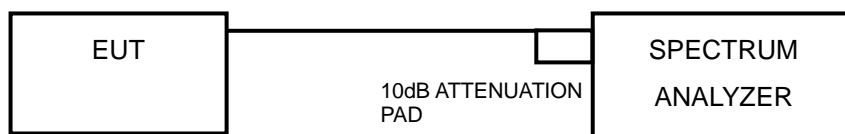

### 4.4.3 TEST INSTRUMENTS

Refer to section 4.1.2 to get information of above instrument.

### 4.4.4 TEST PROCEDURE

- Set the RBW = 3 kHz, VBW =10 kHz, Detector = peak.
- Sweep time = auto couple, Trace mode = max hold, allow trace to fully stabilize.
- Use the peak marker function to determine the maximum power level in any 100 kHz band segment within the fundamental EBW.

### 4.4.5 DEVIATION FROM TEST STANDARD

No deviation.

### 4.4.6 EUT OPERATING CONDITION

Same as section 4.2.6.



#### 4.4.7 TEST RESULTS

##### MODE A

##### 802.11b

CHANNEL	FREQUENCY (MHz)	PSD (dBm/3kHz)	LIMIT (dBm/3kHz)	PASS / FAIL
1	2412	-15.53	8	PASS
6	2437	-6.74	8	PASS
11	2462	-7.86	8	PASS

##### 802.11g

CHANNEL	FREQUENCY (MHz)	PSD (dBm/3kHz)	LIMIT (dBm/3kHz)	PASS / FAIL
1	2412	-17.21	8	PASS
6	2437	-12.97	8	PASS
11	2462	-16.56	8	PASS

##### 802.11n (20MHz)

CHANNEL	FREQUENCY (MHz)	PSD (dBm/3kHz)	LIMIT (dBm/3kHz)	PASS / FAIL
1	2412	-18.74	8	PASS
6	2437	-17.19	8	PASS
11	2462	-16.61	8	PASS

##### 802.11n (40MHz)

CHANNEL	FREQUENCY (MHz)	PSD (dBm/3kHz)	LIMIT (dBm/3kHz)	PASS / FAIL
3	2422	-17.62	8	PASS
6	2437	-16.60	8	PASS
9	2452	-17.65	8	PASS



**MODE C**

**802.11n (20MHz)**

TX Chain	Channel	Freq. (MHz)	PSD (dBm/3kHz)	10 log (N=3) dB	Total PSD (dBm/3kHz)	Limit (dBm/3kHz)	PASS /FAIL
0	1	2412	-16.65	4.77	-11.88	7.23	PASS
	6	2437	-16.22	4.77	-11.45	7.23	PASS
	11	2462	-16.84	4.77	-12.07	7.23	PASS
1	1	2412	-18.63	4.77	-13.86	7.23	PASS
	6	2437	-16.47	4.77	-11.7	7.23	PASS
	11	2462	-17.90	4.77	-13.13	7.23	PASS
2	1	2412	-18.29	4.77	-13.52	7.23	PASS
	6	2437	-16.96	4.77	-12.19	7.23	PASS
	11	2462	-17.96	4.77	-13.19	7.23	PASS

**NOTE:** Directional gain = 2dBi + 10log(3) = 6.77dBi > 6dBi , so the power density limit shall be reduced to 8-(6.77-6) = 7.23dBm.

**802.11n (40MHz)**

TX Chain	Channel	Freq. (MHz)	PSD (dBm/3kHz)	10 log (N=3) dB	Total PSD (dBm/3kHz)	Limit (dBm/3kHz)	PASS /FAIL
0	3	2422	-18.23	4.77	-13.46	7.23	PASS
	6	2437	-17.01	4.77	-12.24	7.23	PASS
	9	2452	-18.68	4.77	-13.91	7.23	PASS
1	3	2422	-17.51	4.77	-12.74	7.23	PASS
	6	2437	-18.13	4.77	-13.36	7.23	PASS
	9	2452	-20.38	4.77	-15.61	7.23	PASS
2	3	2422	-20.66	4.77	-15.89	7.23	PASS
	6	2437	-19.50	4.77	-14.73	7.23	PASS
	9	2452	-20.35	4.77	-15.58	7.23	PASS

**NOTE:** Directional gain = 2dBi + 10log(3) = 6.77dBi > 6dBi , so the power density limit shall be reduced to 8-(6.77-6) = 7.23dBm.



A D T

### SPECTRUM PLOT OF WORST VALUE

#### 802.11b

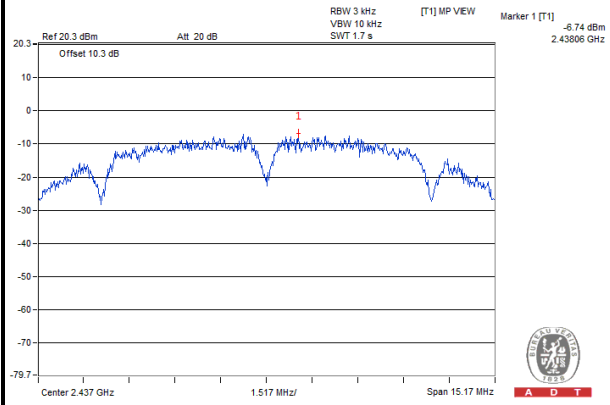

#### 802.11g

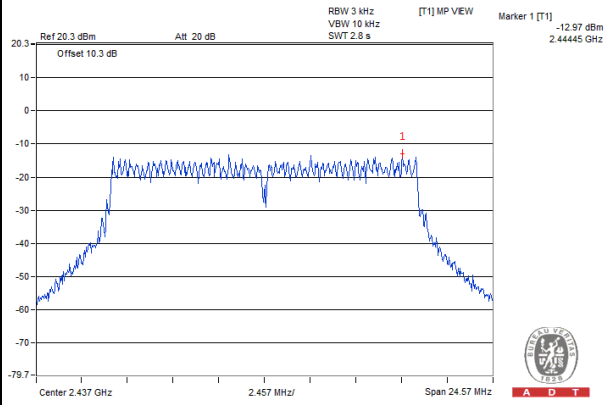

#### 802.11n (20MHz)

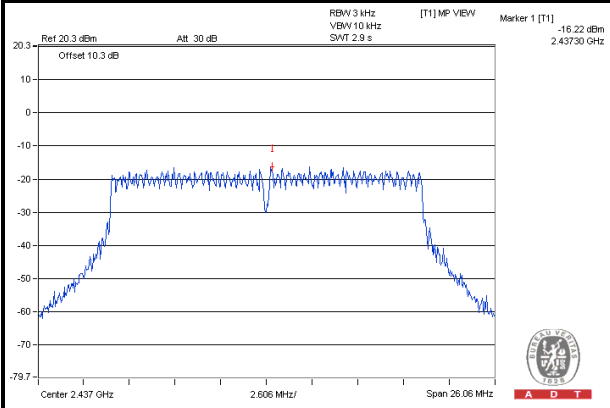

#### 802.11n (40MHz)

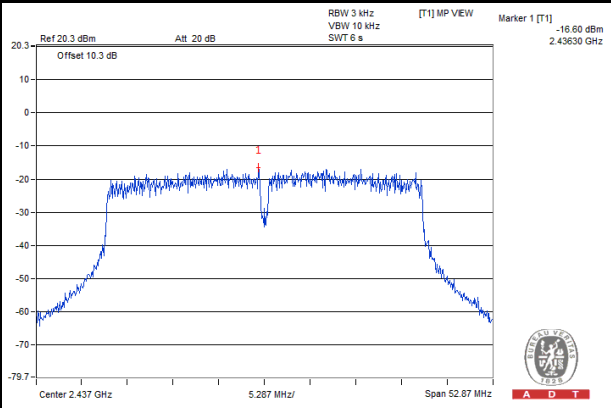

## 4.5 CONDUCTED OUT OF BAND EMISSION MEASUREMENT

### 4.5.1 LIMITS OF CONDUCTED OUT OF BAND EMISSION MEASUREMENT

Below  $-20\text{dB}$  of the highest emission level of operating band (in 100kHz Resolution Bandwidth).

### 4.5.2 TEST SETUP

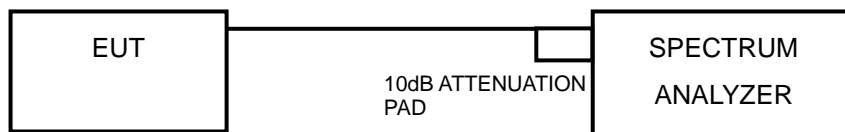

### 4.5.3 TEST INSTRUMENTS

Refer to section 4.1.2 to get information of above instrument.

### 4.5.4 TEST PROCEDURE

#### MEASUREMENT PROCEDURE REF

1. Set the RBW = 100 kHz.
2. Set the VBW  $\geq$  300 kHz.
3. Detector = peak.
4. Sweep time = auto couple.
5. Trace mode = max hold.
6. Allow trace to fully stabilize.
7. Use the peak marker function to determine the maximum power level in any 100 kHz band segment within the fundamental EBW.

#### MEASUREMENT PROCEDURE OOB

1. Set RBW = 100 kHz.
2. Set VBW  $\geq$  300 kHz.
3. Detector = peak.
4. Sweep = auto couple.
5. Trace Mode = max hold.
6. Allow trace to fully stabilize.
7. Use the peak marker function to determine the maximum amplitude level.

### 4.5.5 DEVIATION FROM TEST STANDARD

No deviation.

### 4.5.6 EUT OPERATING CONDITION

Same as section 4.2.6.

### 4.5.7 TEST RESULTS

The conducted emission test is performed on each TX port of operating mode without summing or adding 10log (N) since the limit is relative emission limit.

The spectrum plots are attached on the following images. D1 line indicates the highest level, and D2 line indicates the 20dB offset below D1. It shows compliance with the requirement.

### MODE A

#### 802.11b

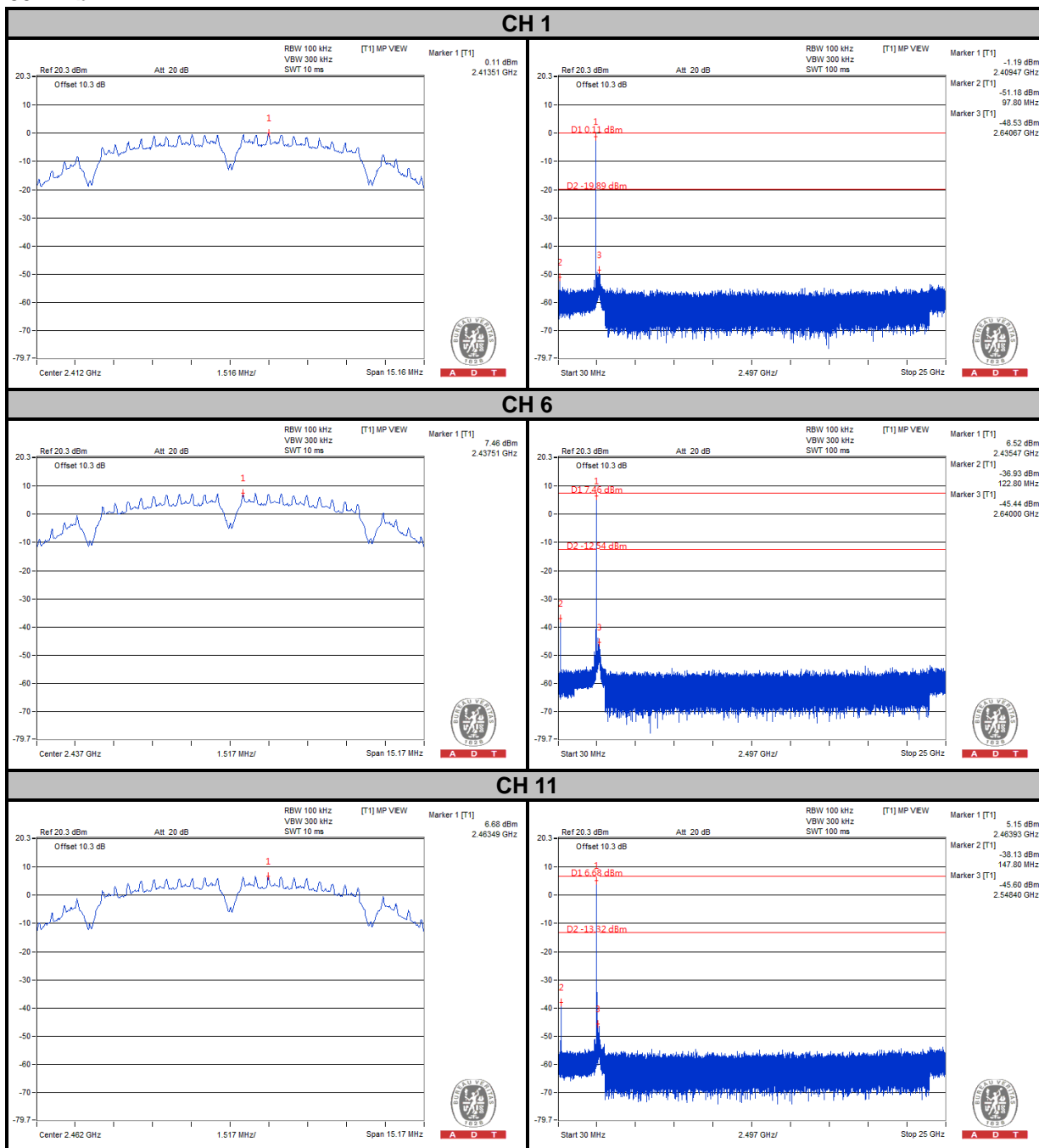



A D T

### 802.11g

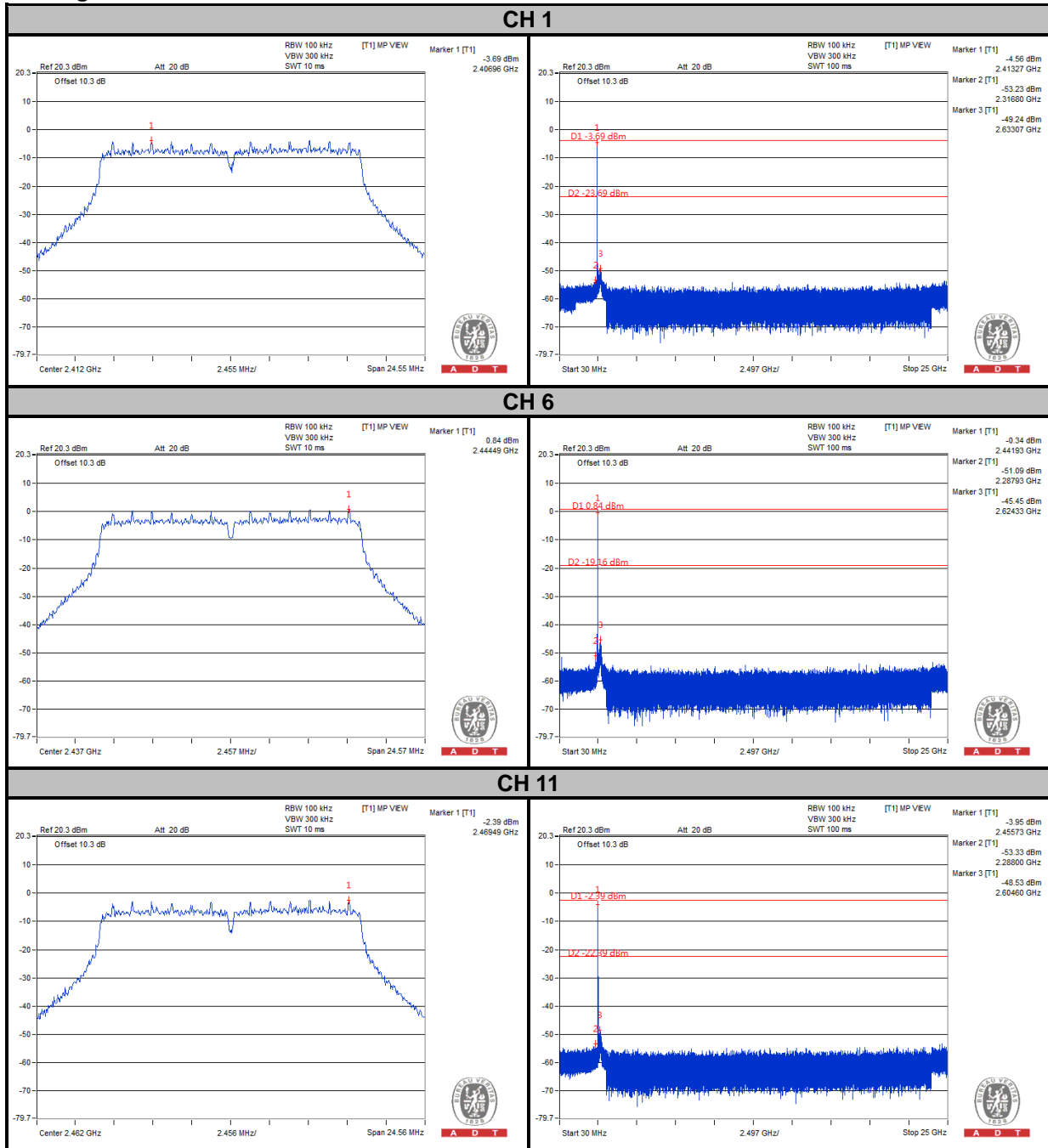



A D T

### 802.11n (20MHz)

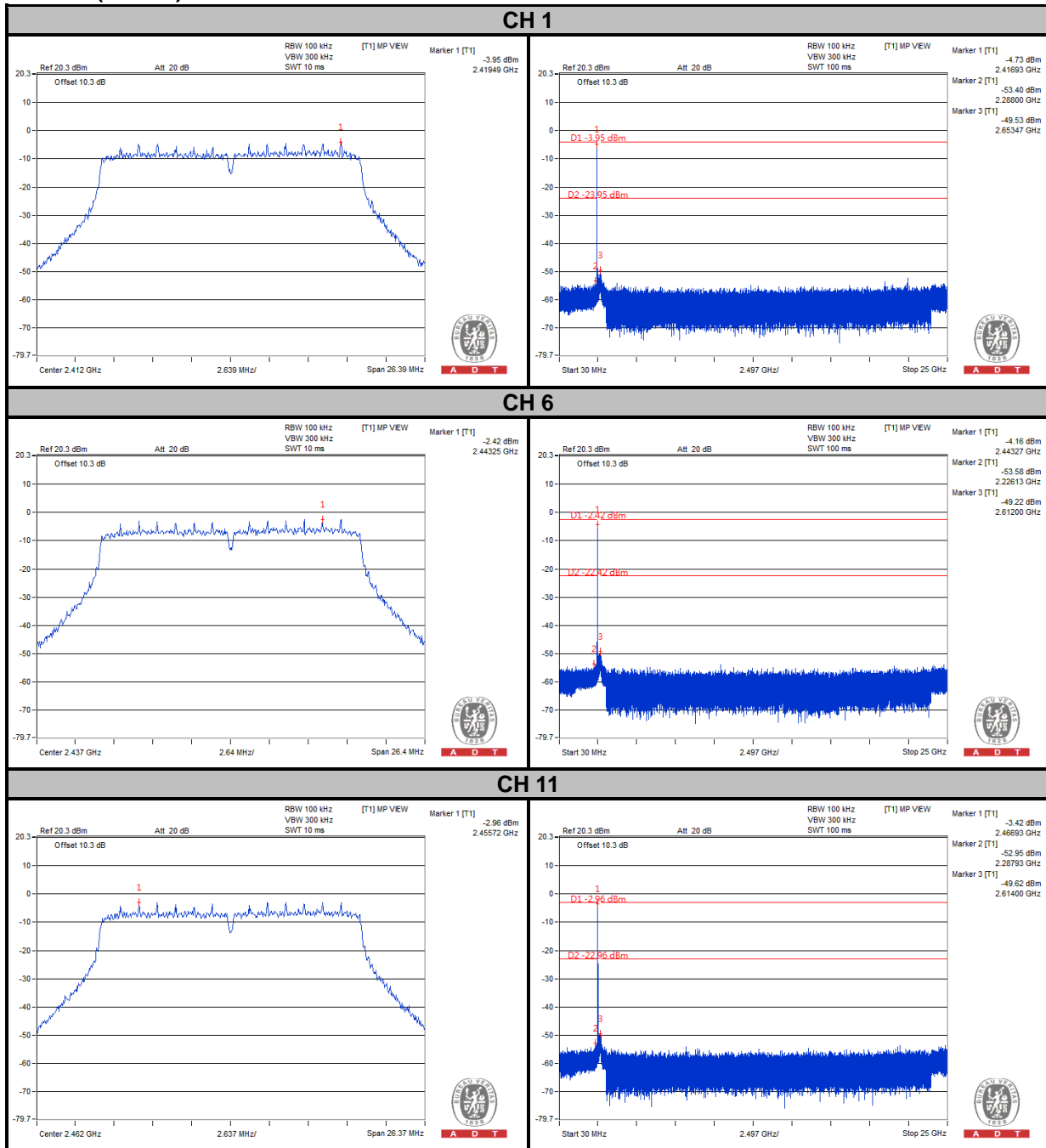





A D T

### 802.11n (40MHz)

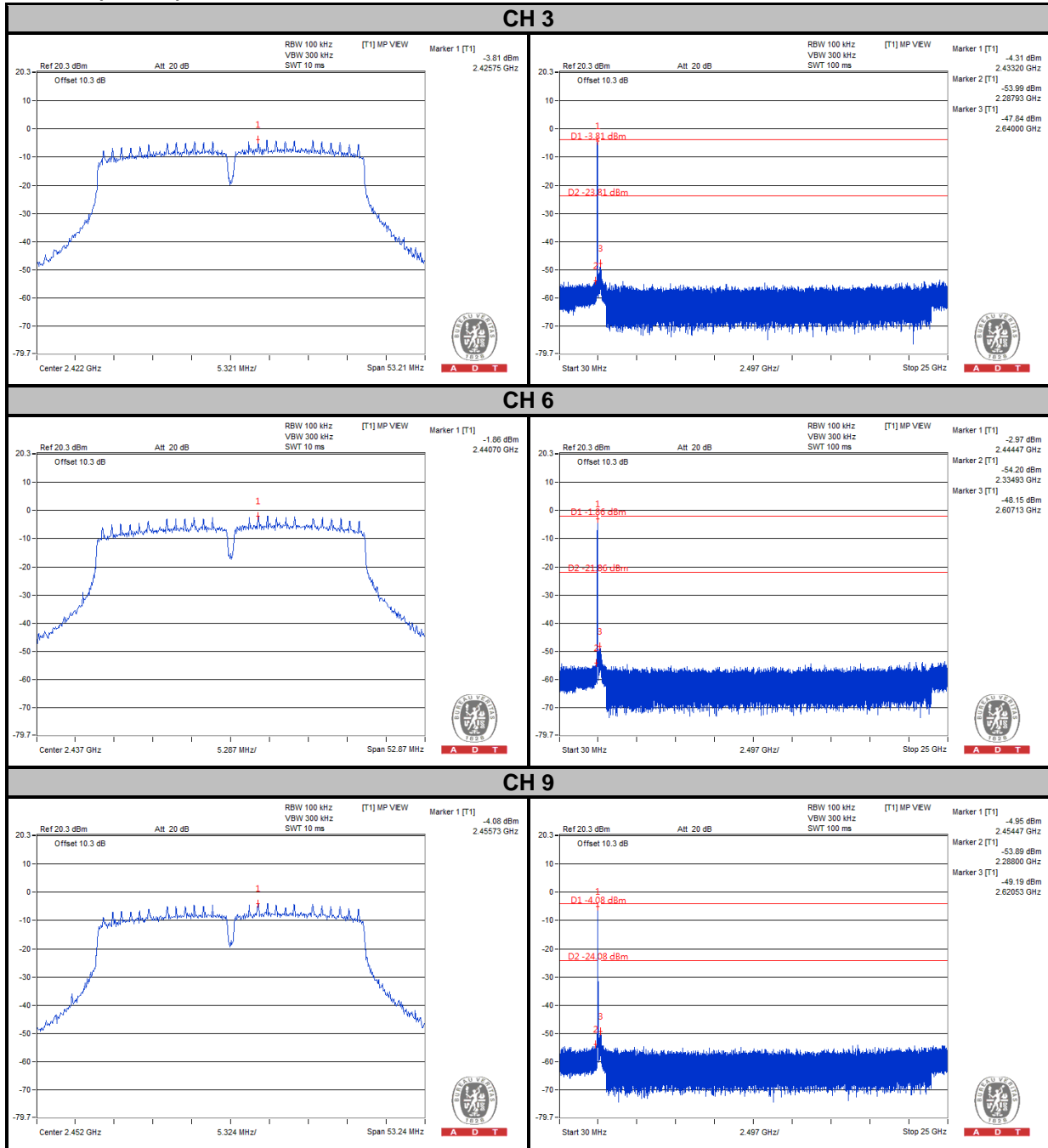



A D T

### MODE C

### 802.11n (20MHz)

### CHAIN 0

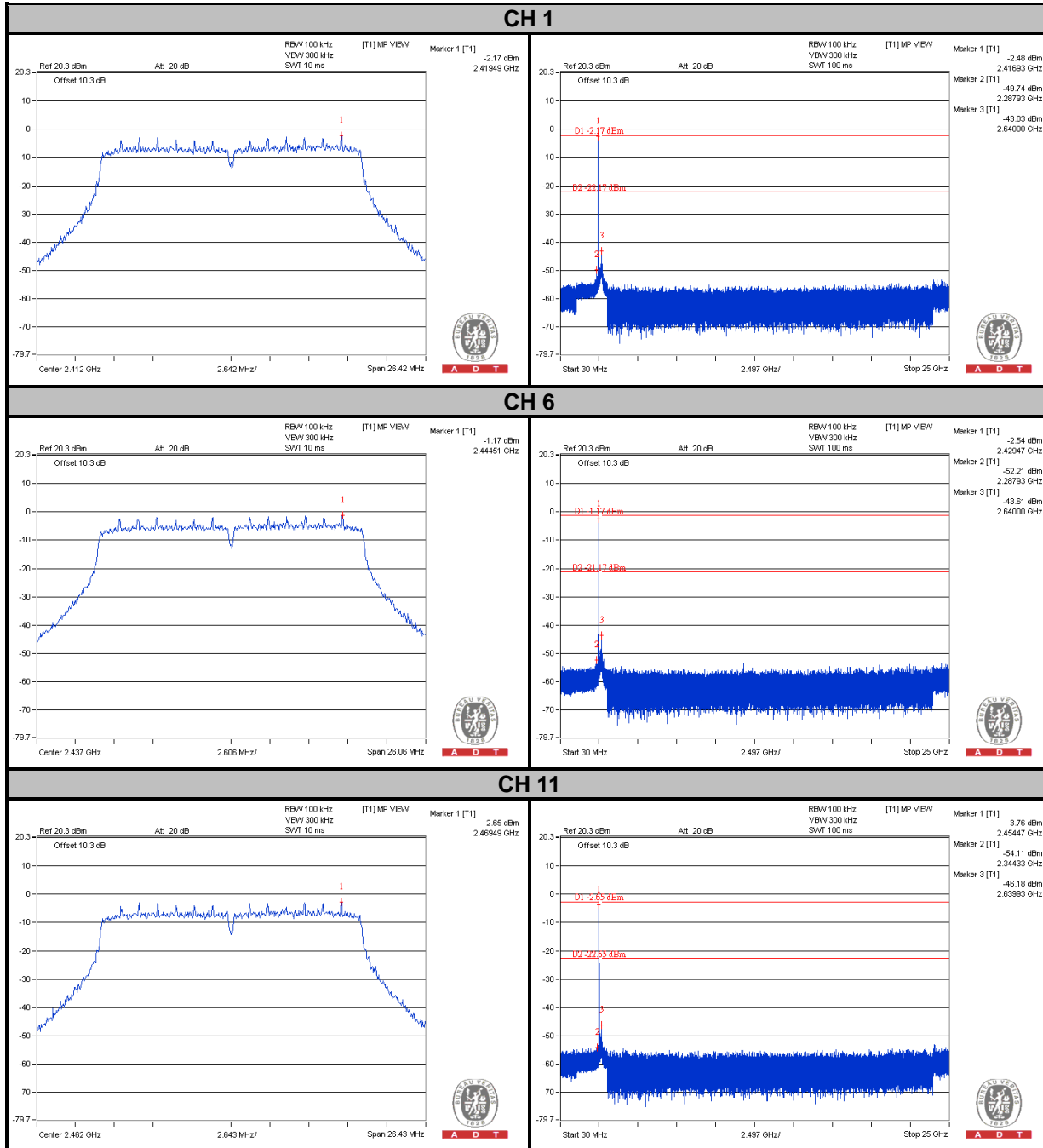



A D T

### CHAIN 1

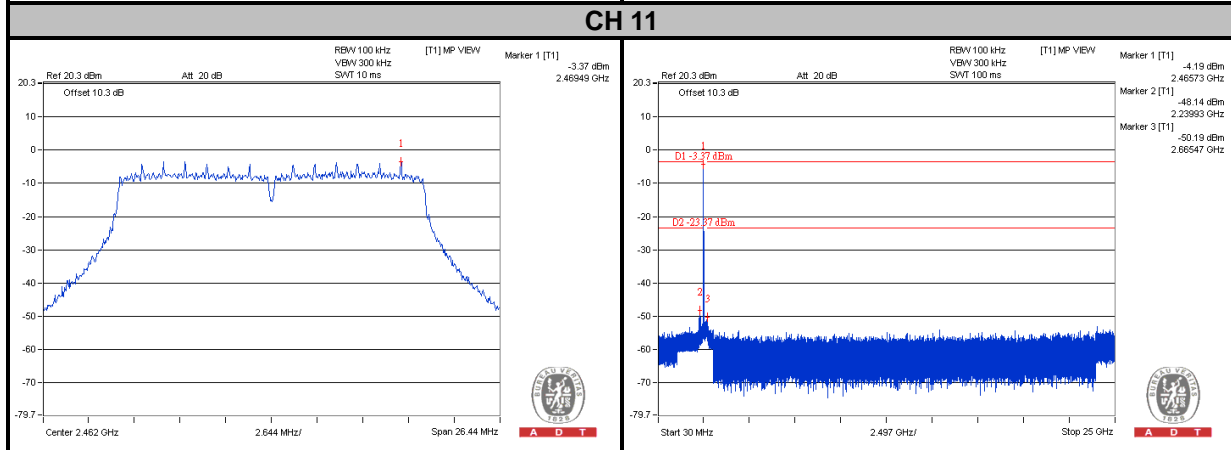
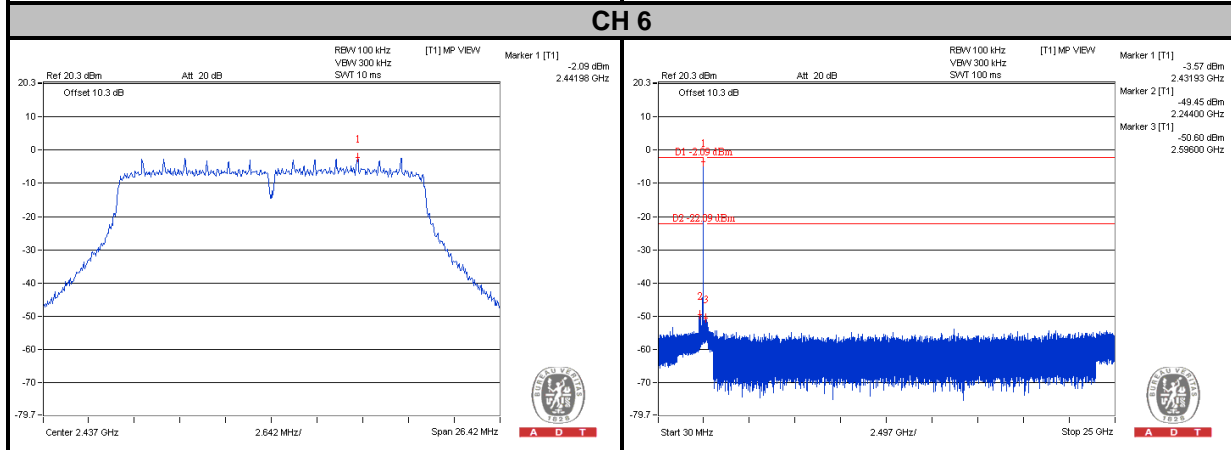
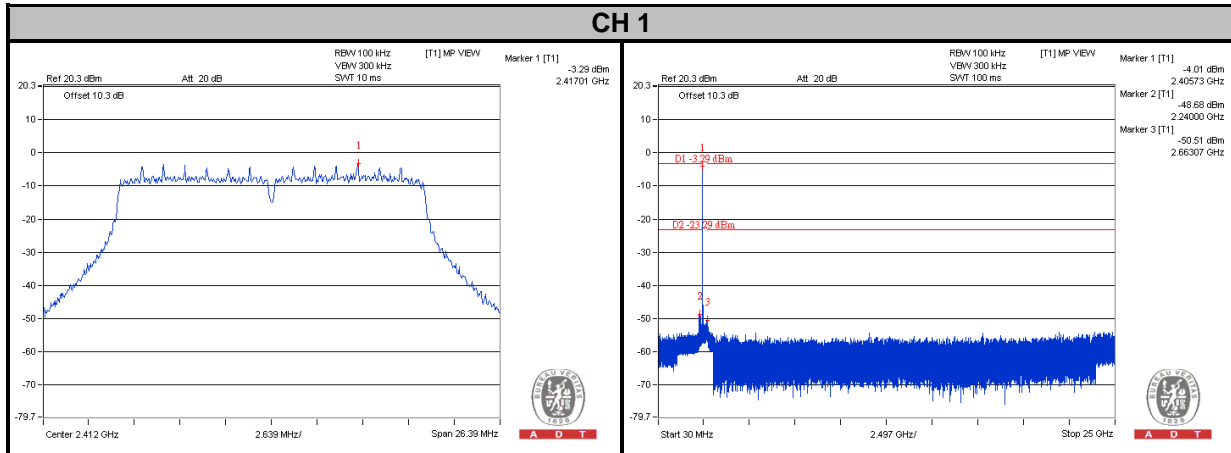



A D T

## CHAIN 2

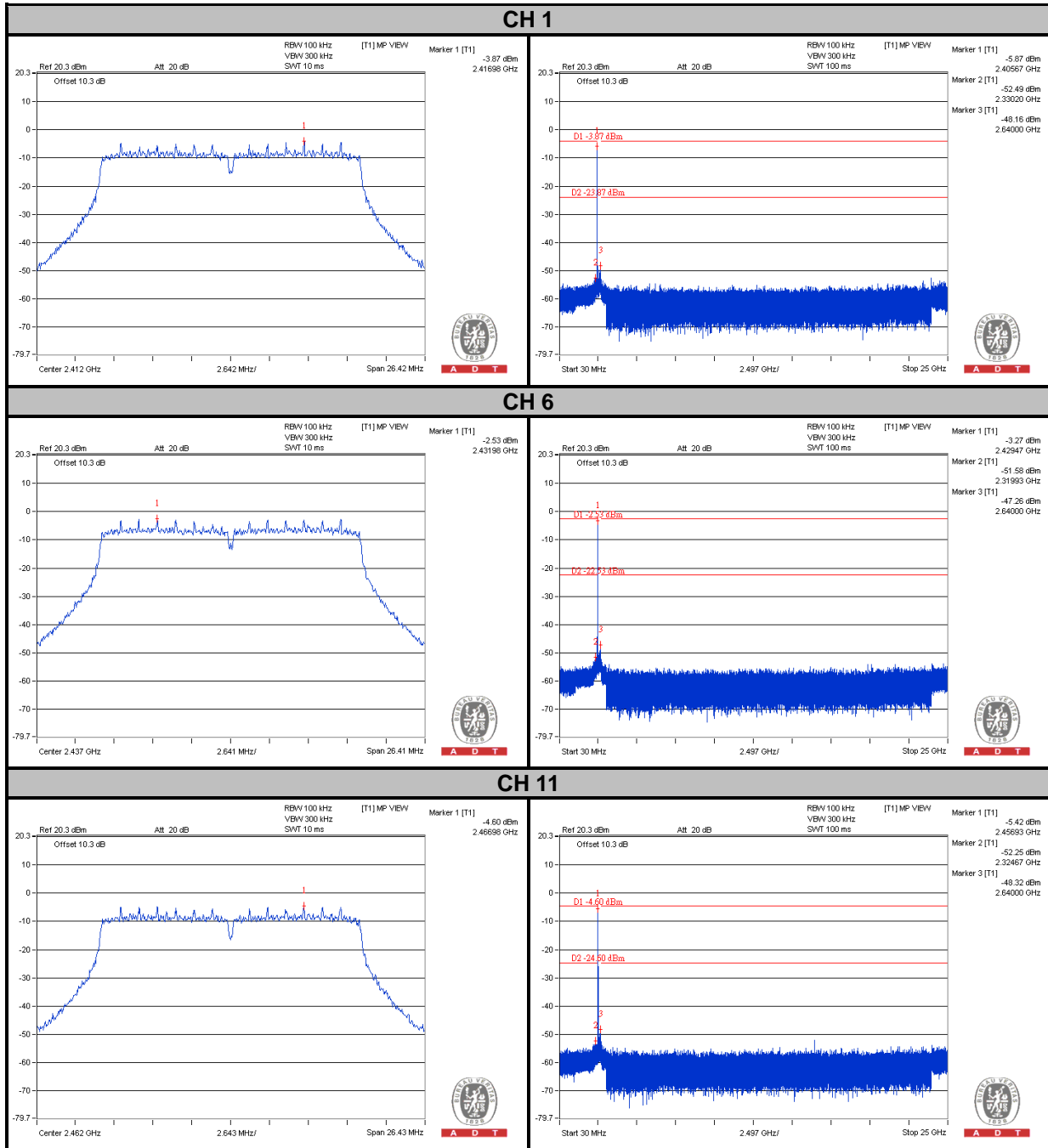



A D T

# 802.11n (40MHz)

## CHAIN 0

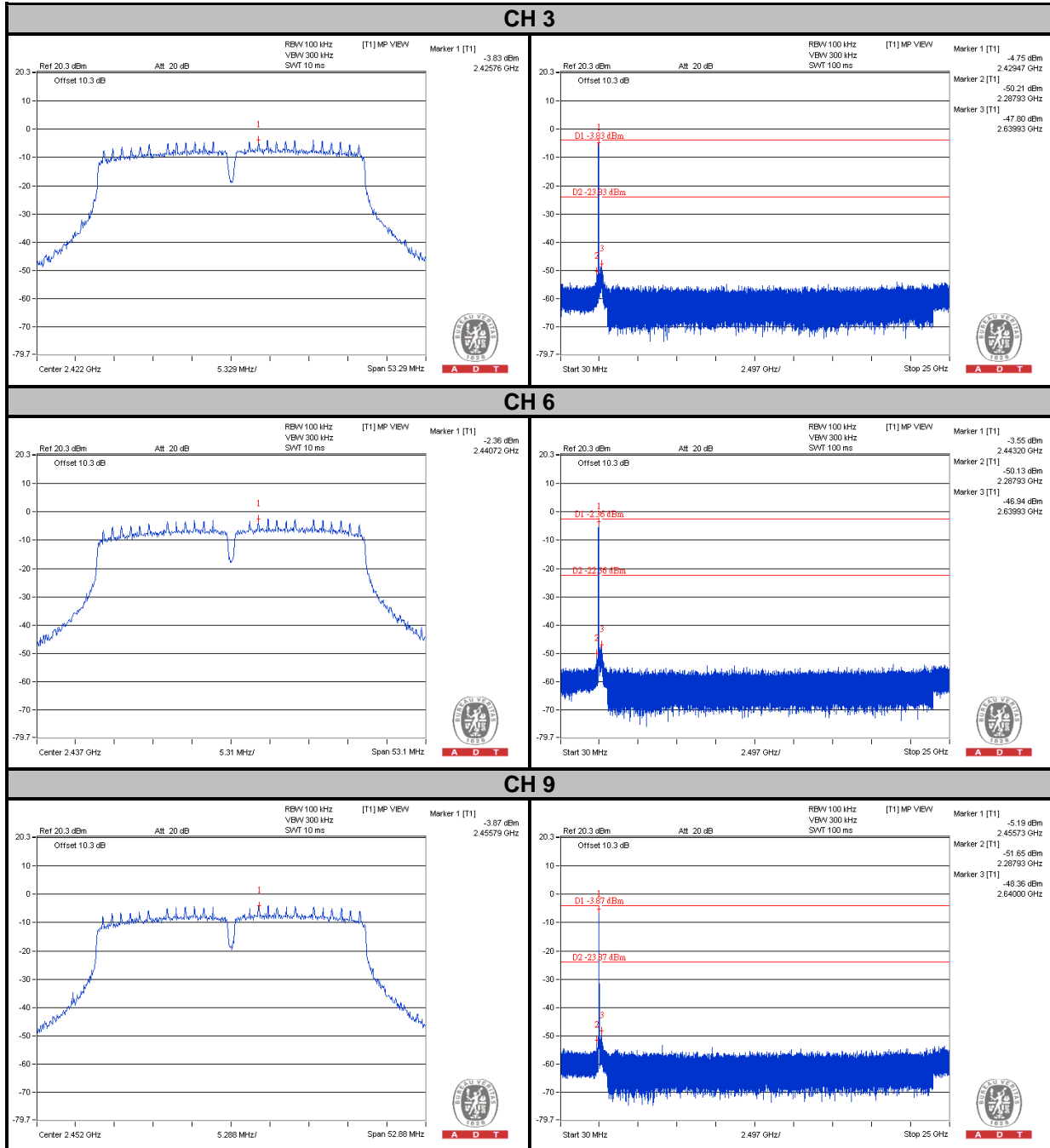



A D T

# CHAIN 1

## CH 3

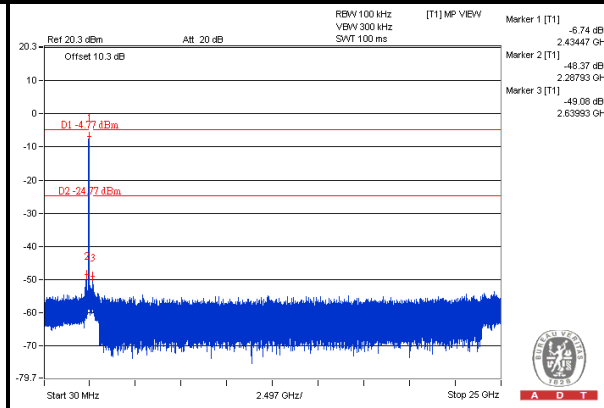
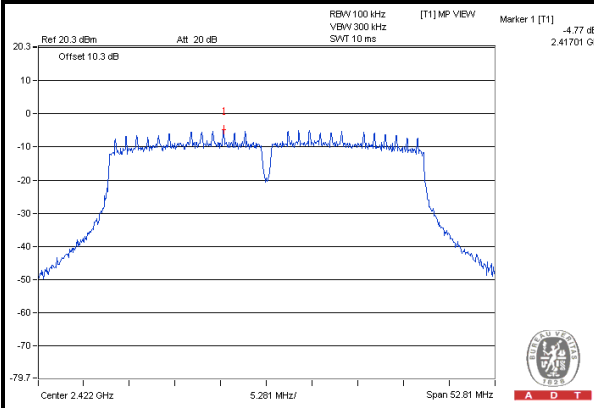

## CH 6

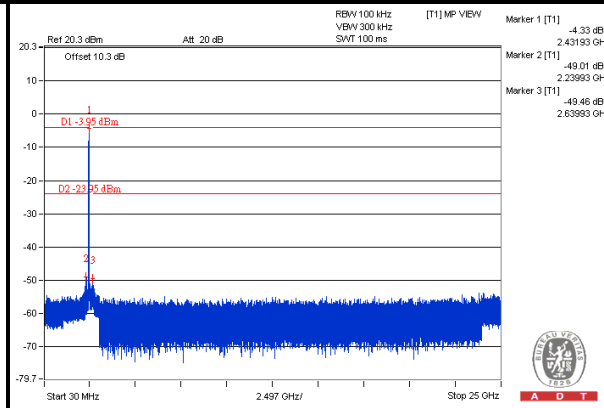
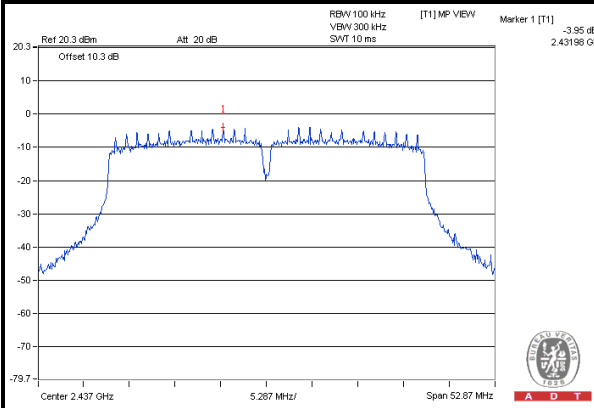

## CH 9

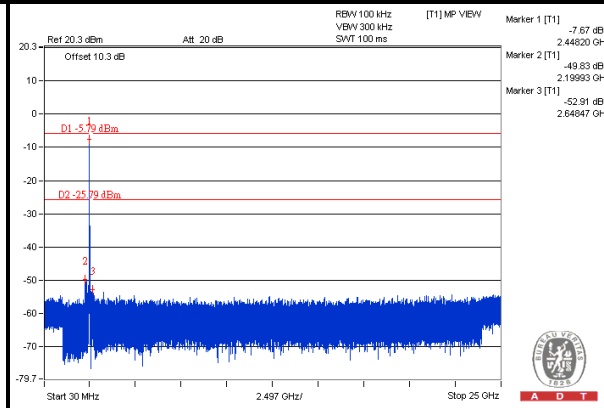
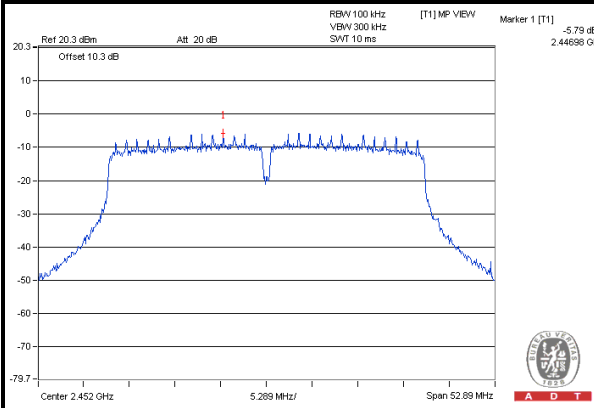



A D T

### CHAIN 2

### CH 3

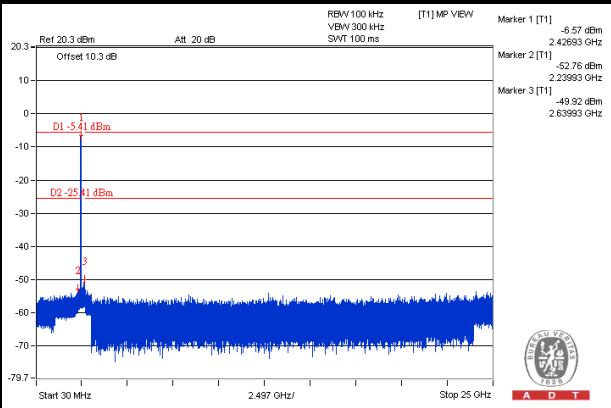
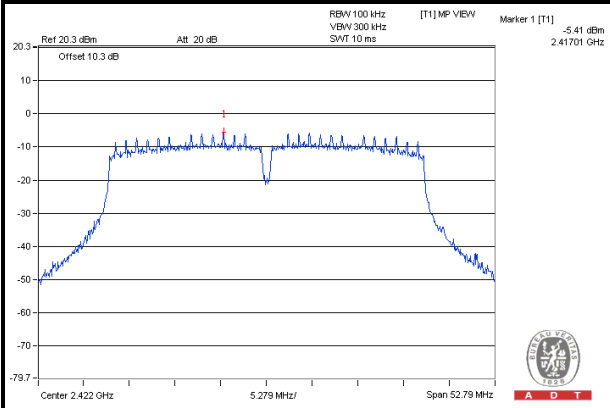

### CH 6

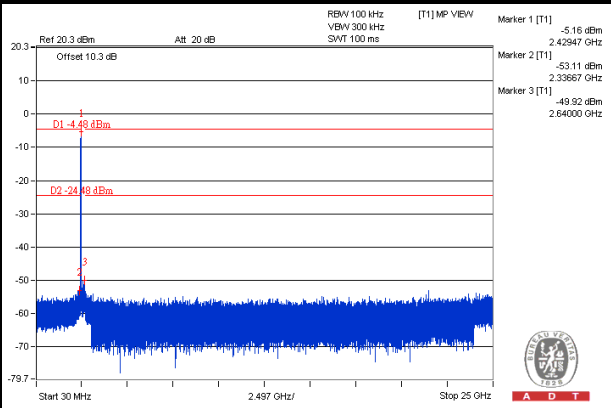
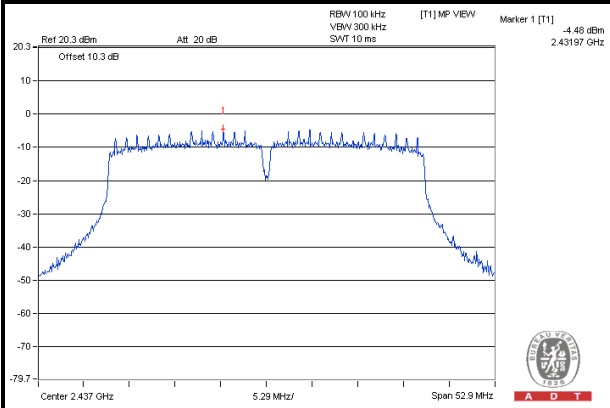

### CH 9

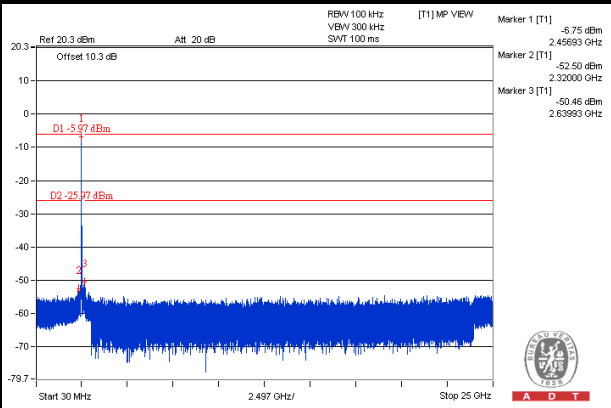
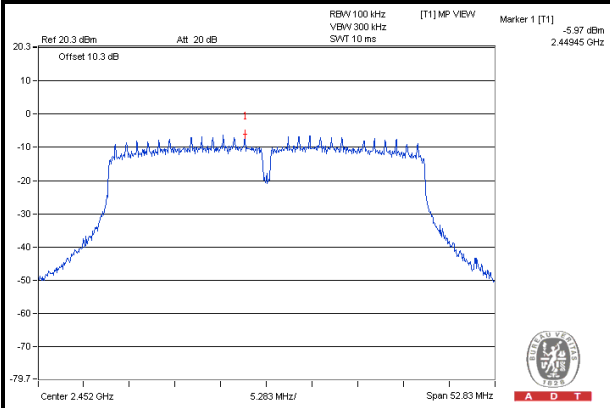

## 5. TEST TYPES AND RESULTS (FOR 5.0GHz BAND)

### 5.1 RADIATED EMISSION AND BANDEDGE MEASUREMENT

#### 5.1.1 LIMITS OF RADIATED EMISSION AND BANDEDGE MEASUREMENT

Radiated emissions which fall in the restricted bands must comply with the radiated emission limits specified as below table. Other emissions shall be at least 20dB below the highest level of the desired power:

FREQUENCIES (MHz)	FIELD STRENGTH (microvolts/meter)	MEASUREMENT DISTANCE (meters)
0.009 ~ 0.490	2400/F(kHz)	300
0.490 ~ 1.705	24000/F(kHz)	30
1.705 ~ 30.0	30	30
30 ~ 88	100	3
88 ~ 216	150	3
216 ~ 960	200	3
Above 960	500	3

**NOTE:**

1. The lower limit shall apply at the transition frequencies.
2. Emission level (dBuV/m) = 20 log Emission level (uV/m).
3. For frequencies above 1000MHz, the field strength limits are based on average detector, however, the peak field strength of any emission shall not exceed the maximum permitted average limits, specified above by more than 20dB under any condition of modulation.





A D T

### **5.1.2 TEST INSTRUMENTS**

Same as section 4.1.2.

### **5.1.3 TEST PROCEDURES**

Same as section 4.1.3.

### **5.1.4 DEVIATION FROM TEST STANDARD**

No deviation.

### **5.1.5 TEST SETUP**

Same as section 4.1.5.

### **5.1.6 EUT OPERATING CONDITIONS**

Same as section 4.1.6.



A D T

5.1.7 TEST RESULTS

MODE A

ABOVE 1GHz WORST-CASE DATA

802.11a

EUT TEST CONDITION		MEASUREMENT DETAIL	
CHANNEL	Channel 149	FREQUENCY RANGE	1GHz ~ 40GHz
INPUT POWER	120Vac, 60 Hz	DETECTOR FUNCTION	Peak (PK) Average (AV)
ENVIRONMENTAL CONDITIONS	25deg. C, 65%RH	TESTED BY	Kay Wu

ANTENNA POLARITY & TEST DISTANCE: HORIZONTAL AT 3 M										
FREQ. (MHz)	EMISSION LEVEL (dBuV/m)	READ LEVEL (dBuV)	LIMIT (dBuV/m)	MARGIN (dB)	ANTENNA FACTOR (dB/m)	CABLE LOSS (dB)	PREAMP FACTOR (dB)	ANTENNA HEIGHT (cm)	TABLE ANGLE (Degree)	REMARK
5725	68.13	58.97	77.83	-9.7	34.62	8.65	34.11	139	72	Average
5725	77.74	68.58	84.7	-6.96	34.62	8.65	34.11	139	72	Peak
5745	97.83	88.64			34.64	8.66	34.11	139	72	Average
5745	104.7	95.51			34.64	8.66	34.11	139	72	Peak
5825	47.94	38.65	77.83	-29.89	34.73	8.69	34.13	139	72	Average
5825	56.12	46.83	84.7	-28.58	34.73	8.69	34.13	139	72	Peak

ANTENNA POLARITY & TEST DISTANCE: VERTICAL AT 3 M										
FREQ. (MHz)	EMISSION LEVEL (dBuV/m)	READ LEVEL (dBuV)	LIMIT (dBuV/m)	MARGIN (dB)	ANTENNA FACTOR (dB/m)	CABLE LOSS (dB)	PREAMP FACTOR (dB)	ANTENNA HEIGHT (cm)	TABLE ANGLE (Degree)	REMARK
5725	72.16	63	83.43	-11.27	34.62	8.65	34.11	113	126	Average
5725	87.88	78.72	90.73	-2.85	34.62	8.65	34.11	113	126	Peak
5745	103.43	94.24			34.64	8.66	34.11	113	126	Average
5745	110.73	101.54			34.64	8.66	34.11	113	126	Peak
5825	48.99	39.7	83.43	-34.44	34.73	8.69	34.13	113	126	Average
5825	56.91	47.62	90.73	-33.82	34.73	8.69	34.13	113	126	Peak

REMARKS:

- Emission Level = Read Level + Antenna Factor + Cable Loss - Preamp Factor  
Margin value = Emission level – Limit value
- 5745MHz: Fundamental frequency.
- 5725MHz & 5825MHz: Out of restricted band



A D T

EUT TEST CONDITION		MEASUREMENT DETAIL	
CHANNEL	Channel 157	FREQUENCY RANGE	1GHz ~ 40GHz
INPUT POWER	120Vac, 60 Hz	DETECTOR FUNCTION	Peak (PK) Average (AV)
ENVIRONMENTAL CONDITIONS	25deg. C, 65%RH	TESTED BY	Kay Wu

**ANTENNA POLARITY & TEST DISTANCE: HORIZONTAL AT 3 M**

FREQ. (MHz)	EMISSION LEVEL (dBuV/m)	READ LEVEL (dBuV)	LIMIT (dBuV/m)	MARGIN (dB)	ANTENNA FACTOR (dB/m)	CABLE LOSS (dB)	PREAMP FACTOR (dB)	ANTENNA HEIGHT (cm)	TABLE ANGLE (Degree)	REMARK
5725	49.17	40.01	77.88	-28.71	34.62	8.65	34.11	138	72	Average
5725	55.73	46.57	85.07	-29.34	34.62	8.65	34.11	138	72	Peak
5785	97.88	88.65			34.68	8.68	34.13	138	72	Average
5785	105.07	95.84			34.68	8.68	34.13	138	72	Peak
5825	53.94	44.65	77.88	-23.94	34.73	8.69	34.13	138	72	Average
5825	58.09	48.8	85.07	-26.98	34.73	8.69	34.13	138	72	Peak

**ANTENNA POLARITY & TEST DISTANCE: VERTICAL AT 3 M**

FREQ. (MHz)	EMISSION LEVEL (dBuV/m)	READ LEVEL (dBuV)	LIMIT (dBuV/m)	MARGIN (dB)	ANTENNA FACTOR (dB/m)	CABLE LOSS (dB)	PREAMP FACTOR (dB)	ANTENNA HEIGHT (cm)	TABLE ANGLE (Degree)	REMARK
5725	50.17	41.01	82.48	-32.31	34.62	8.65	34.11	113	128	Average
5725	56.94	47.78	89.68	-32.74	34.62	8.65	34.11	113	128	Peak
5785	102.48	93.25			34.68	8.68	34.13	113	128	Average
5785	109.68	100.45			34.68	8.68	34.13	113	128	Peak
5825	56.98	47.69	82.48	-25.5	34.73	8.69	34.13	113	128	Average
5825	64.93	55.64	89.68	-24.75	34.73	8.69	34.13	113	128	Peak

**REMARKS:**

- Emission Level = Read Level + Antenna Factor + Cable Loss - Preamp Factor  
Margin value = Emission level – Limit value
- 5785MHz: Fundamental frequency.
- 5725MHz & 5825MHz: Out of restricted band



A D T

EUT TEST CONDITION		MEASUREMENT DETAIL	
CHANNEL	Channel 161	FREQUENCY RANGE	1GHz ~ 40GHz
INPUT POWER	120Vac, 60 Hz	DETECTOR FUNCTION	Peak (PK) Average (AV)
ENVIRONMENTAL CONDITIONS	25deg. C, 65%RH	TESTED BY	Kay Wu

**ANTENNA POLARITY & TEST DISTANCE: HORIZONTAL AT 3 M**

FREQ. (MHz)	EMISSION LEVEL (dBuV/m)	READ LEVEL (dBuV)	LIMIT (dBuV/m)	MARGIN (dB)	ANTENNA FACTOR (dB/m)	CABLE LOSS (dB)	PREAMP FACTOR (dB)	ANTENNA HEIGHT (cm)	TABLE ANGLE (Degree)	REMARK
5725	48.17	39.01	76.63	-28.46	34.62	8.65	34.11	138	72	Average
5725	56.17	47.01	84.28	-28.11	34.62	8.65	34.11	138	72	Peak
5805	96.63	87.37			34.71	8.68	34.13	138	72	Average
5805	104.28	95.02			34.71	8.68	34.13	138	72	Peak
5825	66.65	57.36	76.63	-9.98	34.73	8.69	34.13	138	72	Average
5825	78.77	69.48	84.28	-5.51	34.73	8.69	34.13	138	72	Peak

**ANTENNA POLARITY & TEST DISTANCE: VERTICAL AT 3 M**

FREQ. (MHz)	EMISSION LEVEL (dBuV/m)	READ LEVEL (dBuV)	LIMIT (dBuV/m)	MARGIN (dB)	ANTENNA FACTOR (dB/m)	CABLE LOSS (dB)	PREAMP FACTOR (dB)	ANTENNA HEIGHT (cm)	TABLE ANGLE (Degree)	REMARK
5725	47.84	38.68	82.95	-35.11	34.62	8.65	34.11	113	126	Average
5725	56.49	47.33	89.05	-32.56	34.62	8.65	34.11	113	126	Peak
5805	102.95	93.69			34.71	8.68	34.13	113	126	Average
5805	109.05	99.79			34.71	8.68	34.13	113	126	Peak
5825	70.68	61.39	82.95	-12.27	34.73	8.69	34.13	113	126	Average
5825	84.32	75.03	89.05	-4.73	34.73	8.69	34.13	113	126	Peak

**REMARKS:**

- Emission Level = Read Level + Antenna Factor + Cable Loss - Preamp Factor  
Margin value = Emission level – Limit value
- 5805MHz: Fundamental frequency.
- 5725MHz & 5825MHz: Out of restricted band



A D T

802.11n (20MHz)

EUT TEST CONDITION		MEASUREMENT DETAIL	
CHANNEL	Channel 149	FREQUENCY RANGE	1GHz ~ 40GHz
INPUT POWER	120Vac, 60 Hz	DETECTOR FUNCTION	Peak (PK) Average (AV)
ENVIRONMENTAL CONDITIONS	25deg. C, 65%RH	TESTED BY	Kay Wu

ANTENNA POLARITY & TEST DISTANCE: HORIZONTAL AT 3 M

FREQ. (MHz)	EMISSION LEVEL (dBuV/m)	READ LEVEL (dBuV)	LIMIT (dBuV/m)	MARGIN (dB)	ANTENNA FACTOR (dB/m)	CABLE LOSS (dB)	PREAMP FACTOR (dB)	ANTENNA HEIGHT (cm)	TABLE ANGLE (Degree)	REMARK
5725	63.84	54.68	75.54	-11.7	34.62	8.65	34.11	138	72	Average
5725	78.1	68.94	83.21	-5.11	34.62	8.65	34.11	138	72	Peak
5745	95.54	86.35			34.64	8.66	34.11	138	72	Average
5745	103.21	94.02			34.64	8.66	34.11	138	72	Peak
5825	48.07	38.78	75.54	-27.47	34.73	8.69	34.13	138	72	Average
5825	55.71	46.42	83.21	-27.5	34.73	8.69	34.13	138	72	Peak

ANTENNA POLARITY & TEST DISTANCE: VERTICAL AT 3 M

FREQ. (MHz)	EMISSION LEVEL (dBuV/m)	READ LEVEL (dBuV)	LIMIT (dBuV/m)	MARGIN (dB)	ANTENNA FACTOR (dB/m)	CABLE LOSS (dB)	PREAMP FACTOR (dB)	ANTENNA HEIGHT (cm)	TABLE ANGLE (Degree)	REMARK
5725	69.93	60.77	81.86	-11.93	34.62	8.65	34.11	123	123	Average
5725	79.18	70.02	88.6	-9.42	34.62	8.65	34.11	123	123	Peak
5745	101.86	92.67			34.64	8.66	34.11	123	123	Average
5745	108.6	99.41			34.64	8.66	34.11	123	123	Peak
5825	48.65	39.36	81.86	-33.21	34.73	8.69	34.13	123	123	Average
5825	55.96	46.67	88.6	-32.64	34.73	8.69	34.13	123	123	Peak

REMARKS:

- Emission Level = Read Level + Antenna Factor + Cable Loss - Preamp Factor  
Margin value = Emission level – Limit value
- 5745MHz: Fundamental frequency.
- 5725MHz & 5825MHz: Out of restricted band



A D T

EUT TEST CONDITION		MEASUREMENT DETAIL	
CHANNEL	Channel 157	FREQUENCY RANGE	1GHz ~ 40GHz
INPUT POWER	120Vac, 60 Hz	DETECTOR FUNCTION	Peak (PK) Average (AV)
ENVIRONMENTAL CONDITIONS	25deg. C, 65%RH	TESTED BY	Kay Wu

**ANTENNA POLARITY & TEST DISTANCE: HORIZONTAL AT 3 M**

FREQ. (MHz)	EMISSION LEVEL (dBuV/m)	READ LEVEL (dBuV)	LIMIT (dBuV/m)	MARGIN (dB)	ANTENNA FACTOR (dB/m)	CABLE LOSS (dB)	PREAMP FACTOR (dB)	ANTENNA HEIGHT (cm)	TABLE ANGLE (Degree)	REMARK
5725	48.17	39.01	75.92	-27.75	34.62	8.65	34.11	138	72	Average
5725	56.46	47.3	84.05	-27.59	34.62	8.65	34.11	138	72	Peak
5785	95.92	86.69			34.68	8.68	34.13	138	72	Average
5785	104.05	94.82			34.68	8.68	34.13	138	72	Peak
5825	49.28	39.99	75.92	-26.64	34.73	8.69	34.13	138	72	Average
5825	56.67	47.38	84.05	-27.38	34.73	8.69	34.13	138	72	Peak

**ANTENNA POLARITY & TEST DISTANCE: VERTICAL AT 3 M**

FREQ. (MHz)	EMISSION LEVEL (dBuV/m)	READ LEVEL (dBuV)	LIMIT (dBuV/m)	MARGIN (dB)	ANTENNA FACTOR (dB/m)	CABLE LOSS (dB)	PREAMP FACTOR (dB)	ANTENNA HEIGHT (cm)	TABLE ANGLE (Degree)	REMARK
5725	49.84	40.68	81.88	-32.04	34.62	8.65	34.11	113	126	Average
5725	56.81	47.65	88.9	-32.09	34.62	8.65	34.11	113	126	Peak
5785	101.88	92.65			34.68	8.68	34.13	113	126	Average
5785	108.9	99.67			34.68	8.68	34.13	113	126	Peak
5825	53.32	44.03	81.88	-28.56	34.73	8.69	34.13	113	126	Average
5825	59.35	50.06	88.9	-29.55	34.73	8.69	34.13	113	126	Peak

**REMARKS:**

- Emission Level = Read Level + Antenna Factor + Cable Loss - Preamp Factor  
Margin value = Emission level – Limit value
- 5785MHz: Fundamental frequency.
- 5725MHz & 5825MHz: Out of restricted band



A D T

EUT TEST CONDITION		MEASUREMENT DETAIL	
CHANNEL	Channel 161	FREQUENCY RANGE	1GHz ~ 40GHz
INPUT POWER	120Vac, 60 Hz	DETECTOR FUNCTION	Peak (PK) Average (AV)
ENVIRONMENTAL CONDITIONS	25deg. C, 65%RH	TESTED BY	Kay Wu

**ANTENNA POLARITY & TEST DISTANCE: HORIZONTAL AT 3 M**

FREQ. (MHz)	EMISSION LEVEL (dBuV/m)	READ LEVEL (dBuV)	LIMIT (dBuV/m)	MARGIN (dB)	ANTENNA FACTOR (dB/m)	CABLE LOSS (dB)	PREAMP FACTOR (dB)	ANTENNA HEIGHT (cm)	TABLE ANGLE (Degree)	REMARK
5725	47.84	38.68	76.29	-28.45	34.62	8.65	34.11	138	72	Average
5725	55.33	46.17	83.72	-28.39	34.62	8.65	34.11	138	72	Peak
5805	96.29	87.03			34.71	8.68	34.13	138	72	Average
5805	103.72	94.46			34.71	8.68	34.13	138	72	Peak
5825	63.99	54.7	76.29	-12.3	34.73	8.69	34.13	138	72	Average
5825	74.8	65.51	83.72	-8.92	34.73	8.69	34.13	138	72	Peak

**ANTENNA POLARITY & TEST DISTANCE: VERTICAL AT 3 M**

FREQ. (MHz)	EMISSION LEVEL (dBuV/m)	READ LEVEL (dBuV)	LIMIT (dBuV/m)	MARGIN (dB)	ANTENNA FACTOR (dB/m)	CABLE LOSS (dB)	PREAMP FACTOR (dB)	ANTENNA HEIGHT (cm)	TABLE ANGLE (Degree)	REMARK
5725	47.84	38.68	81.96	-34.12	34.62	8.65	34.11	113	126	Average
5725	57.88	48.72	88.41	-30.53	34.62	8.65	34.11	113	126	Peak
5805	101.96	92.7			34.71	8.68	34.13	113	126	Average
5805	108.41	99.15			34.71	8.68	34.13	113	126	Peak
5825	65.99	56.7	81.96	-15.97	34.73	8.69	34.13	113	126	Average
5825	78.47	69.18	88.41	-9.94	34.73	8.69	34.13	113	126	Peak

**REMARKS:**

- Emission Level = Read Level + Antenna Factor + Cable Loss - Preamp Factor  
Margin value = Emission level – Limit value
- 5805MHz: Fundamental frequency.
- 5725MHz & 5825MHz: Out of restricted band



A D T

802.11n (40MHz)

EUT TEST CONDITION		MEASUREMENT DETAIL	
CHANNEL	Channel 151	FREQUENCY RANGE	1GHz ~ 40GHz
INPUT POWER	120Vac, 60 Hz	DETECTOR FUNCTION	Peak (PK) Average (AV)
ENVIRONMENTAL CONDITIONS	25deg. C, 65%RH	TESTED BY	Kay Wu

ANTENNA POLARITY & TEST DISTANCE: HORIZONTAL AT 3 M

FREQ. (MHz)	EMISSION LEVEL (dBuV/m)	READ LEVEL (dBuV)	LIMIT (dBuV/m)	MARGIN (dB)	ANTENNA FACTOR (dB/m)	CABLE LOSS (dB)	PREAMP FACTOR (dB)	ANTENNA HEIGHT (cm)	TABLE ANGLE (Degree)	REMARK
5725	68.84	59.68	75.55	-6.71	34.62	8.65	34.11	138	72	Average
5725	77.65	68.49	82.8	-5.15	34.62	8.65	34.11	138	72	Peak
5755	95.55	86.34			34.66	8.66	34.11	138	72	Average
5755	102.8	93.59			34.66	8.66	34.11	138	72	Peak
5825	51.99	42.7	75.55	-23.56	34.73	8.69	34.13	138	72	Average
5825	58.47	49.18	82.8	-24.33	34.73	8.69	34.13	138	72	Peak

ANTENNA POLARITY & TEST DISTANCE: VERTICAL AT 3 M

FREQ. (MHz)	EMISSION LEVEL (dBuV/m)	READ LEVEL (dBuV)	LIMIT (dBuV/m)	MARGIN (dB)	ANTENNA FACTOR (dB/m)	CABLE LOSS (dB)	PREAMP FACTOR (dB)	ANTENNA HEIGHT (cm)	TABLE ANGLE (Degree)	REMARK
5725	73.87	64.71	80.21	-6.34	34.62	8.65	34.11	113	126	Average
5725	83.38	74.22	87.75	-4.37	34.62	8.65	34.11	113	126	Peak
5755	100.21	91			34.66	8.66	34.11	113	126	Average
5755	107.75	98.54			34.66	8.66	34.11	113	126	Peak
5825	49.32	40.03	80.21	-30.89	34.73	8.69	34.13	113	126	Average
5825	58.77	49.48	87.75	-28.98	34.73	8.69	34.13	113	126	Peak

REMARKS:

- Emission Level = Read Level + Antenna Factor + Cable Loss - Preamp Factor  
Margin value = Emission level – Limit value
- 5755MHz: Fundamental frequency.
- 5725MHz & 5825MHz: Out of restricted band





A D T

EUT TEST CONDITION		MEASUREMENT DETAIL	
CHANNEL	Channel 159	FREQUENCY RANGE	1GHz ~ 40GHz
INPUT POWER	120Vac, 60 Hz	DETECTOR FUNCTION	Peak (PK) Average (AV)
ENVIRONMENTAL CONDITIONS	25deg. C, 65%RH	TESTED BY	Kay Wu

**ANTENNA POLARITY & TEST DISTANCE: HORIZONTAL AT 3 M**

FREQ. (MHz)	EMISSION LEVEL (dBuV/m)	READ LEVEL (dBuV)	LIMIT (dBuV/m)	MARGIN (dB)	ANTENNA FACTOR (dB/m)	CABLE LOSS (dB)	PREAMP FACTOR (dB)	ANTENNA HEIGHT (cm)	TABLE ANGLE (Degree)	REMARK
5725	51.84	42.68	75.5	-23.66	34.62	8.65	34.11	138	72	Average
5725	61.09	51.93	82.84	-21.75	34.62	8.65	34.11	138	72	Peak
5795	95.5	86.26			34.69	8.68	34.13	138	72	Average
5795	102.84	93.6			34.69	8.68	34.13	138	72	Peak
5825	69.99	60.7	75.5	-5.51	34.73	8.69	34.13	138	72	Average
5825	79.31	70.02	82.84	-3.53	34.73	8.69	34.13	138	72	Peak

**ANTENNA POLARITY & TEST DISTANCE: VERTICAL AT 3 M**

FREQ. (MHz)	EMISSION LEVEL (dBuV/m)	READ LEVEL (dBuV)	LIMIT (dBuV/m)	MARGIN (dB)	ANTENNA FACTOR (dB/m)	CABLE LOSS (dB)	PREAMP FACTOR (dB)	ANTENNA HEIGHT (cm)	TABLE ANGLE (Degree)	REMARK
5725	55.69	46.53	80.27	-24.58	34.62	8.65	34.11	113	126	Average
5725	63.48	54.32	87.63	-24.15	34.62	8.65	34.11	113	126	Peak
5795	100.27	91.03			34.69	8.68	34.13	113	126	Average
5795	107.63	98.39			34.69	8.68	34.13	113	126	Peak
5825	73.32	64.03	80.27	-6.95	34.73	8.69	34.13	113	126	Average
5825	83.96	74.67	87.63	-3.67	34.73	8.69	34.13	113	126	Peak

**REMARKS:**

- Emission Level = Read Level + Antenna Factor + Cable Loss - Preamp Factor  
Margin value = Emission level – Limit value
- 5795MHz: Fundamental frequency.
- 5725MHz & 5825MHz: Out of restricted band



A D T

**BELOW 1GHz WORST-CASE DATA:**

**802.11a**

EUT TEST CONDITION		MEASUREMENT DETAIL	
CHANNEL	Channel 149	FREQUENCY RANGE	30MHz ~ 1GHz
INPUT POWER	120Vac, 60 Hz	DETECTOR FUNCTION	Peak (PK)
ENVIRONMENTAL CONDITIONS	25deg. C, 65%RH	TESTED BY	Kay Wu

ANTENNA POLARITY & TEST DISTANCE: HORIZONTAL AT 3 M										
FREQ. (MHz)	EMISSION LEVEL (dBuV/m)	READ LEVEL (dBuV)	LIMIT (dBuV/m)	MARGIN (dB)	ANTENNA FACTOR (dB/m)	CABLE LOSS (dB)	PREAMP FACTOR (dB)	ANTENNA HEIGHT (cm)	TABLE ANGLE (Degree)	REMARK
99.93	23.62	44.94	43.5	-19.88	9.66	1.28	32.26	165	215	Peak
166.62	24.02	44.46	43.5	-19.48	10.29	1.52	32.25	155	145	Peak
200.1	37.61	57.36	43.5	-5.89	10.9	1.65	32.3	102	135	Peak
318.2	38.54	53.69	46	-7.46	14.85	2.11	32.11	105	165	Peak
499.5	34.03	44.5	46	-11.97	19	2.63	32.1	157	114	Peak
700.4	30.38	36.26	46	-15.62	23.1	3.11	32.09	158	51	Peak
ANTENNA POLARITY & TEST DISTANCE: VERTICAL AT 3 M										
FREQ. (MHz)	EMISSION LEVEL (dBuV/m)	READ LEVEL (dBuV)	LIMIT (dBuV/m)	MARGIN (dB)	ANTENNA FACTOR (dB/m)	CABLE LOSS (dB)	PREAMP FACTOR (dB)	ANTENNA HEIGHT (cm)	TABLE ANGLE (Degree)	REMARK
30.27	31.96	45.94	40	-8.04	17.55	0.74	32.27	161	201	Peak
99.66	23.4	44.72	43.5	-20.1	9.66	1.28	32.26	155	124	Peak
300	36.84	53.05	46	-9.16	13.9	2.03	32.14	100	360	Peak
497.4	31.35	41.83	46	-14.65	18.99	2.63	32.1	157	154	Peak
664	28.03	34.42	46	-17.97	22.75	2.99	32.13	158	102	Peak
700.4	27.59	33.47	46	-18.41	23.1	3.11	32.09	155	220	Peak

**REMARKS:** Emission Level = Read Level + Antenna Factor + Cable Loss - Preamp Factor

Margin value = Emission level – Limit value



A D T

**MODE C**

**802.11n (20MHz)**

EUT TEST CONDITION		MEASUREMENT DETAIL	
CHANNEL	Channel 149	FREQUENCY RANGE	1GHz ~ 40GHz
INPUT POWER	120Vac, 60 Hz	DETECTOR FUNCTION	Peak (PK) Average (AV)
ENVIRONMENTAL CONDITIONS	25deg. C, 65%RH	TESTED BY	Kay Wu

**ANTENNA POLARITY & TEST DISTANCE: HORIZONTAL AT 3 M**

FREQ. (MHz)	EMISSION LEVEL (dBuV/m)	READ LEVEL (dBuV)	LIMIT (dBuV/m)	MARGIN (dB)	ANTENNA FACTOR (dB/m)	CABLE LOSS (dB)	PREAMP FACTOR (dB)	ANTENNA HEIGHT (cm)	TABLE ANGLE (Degree)	REMARK
5725	62.13	52.97	79.2	-17.07	34.62	8.65	34.11	145	96	Average
5725	68.02	58.86	86.81	-18.79	34.62	8.65	34.11	145	96	Peak
5745	99.2	90.01			34.64	8.66	34.11	145	96	Average
5745	106.81	97.62			34.64	8.66	34.11	145	96	Peak
5825	48.32	39.03	79.2	-30.88	34.73	8.69	34.13	145	96	Average
5825	55.64	46.35	86.81	-31.17	34.73	8.69	34.13	145	96	Peak

**ANTENNA POLARITY & TEST DISTANCE: VERTICAL AT 3 M**

FREQ. (MHz)	EMISSION LEVEL (dBuV/m)	READ LEVEL (dBuV)	LIMIT (dBuV/m)	MARGIN (dB)	ANTENNA FACTOR (dB/m)	CABLE LOSS (dB)	PREAMP FACTOR (dB)	ANTENNA HEIGHT (cm)	TABLE ANGLE (Degree)	REMARK
5725	66.8	57.64	86.87	-20.07	34.62	8.65	34.11	134	270	Average
5725	76.71	67.55	93.37	-16.66	34.62	8.65	34.11	134	270	Peak
5745	106.87	97.68			34.64	8.66	34.11	134	270	Average
5745	113.37	104.18			34.64	8.66	34.11	134	270	Peak
5825	49.32	40.03	86.87	-37.55	34.73	8.69	34.13	134	270	Average
5825	56.49	47.2	93.37	-36.88	34.73	8.69	34.13	134	270	Peak

**REMARKS:**

- Emission Level = Read Level + Antenna Factor + Cable Loss - Preamp Factor  
Margin value = Emission level – Limit value
- 5745MHz: Fundamental frequency.
- 5725MHz & 5825MHz: Out of restricted band



A D T

EUT TEST CONDITION		MEASUREMENT DETAIL	
CHANNEL	Channel 157	FREQUENCY RANGE	1GHz ~ 40GHz
INPUT POWER	120Vac, 60 Hz	DETECTOR FUNCTION	Peak (PK) Average (AV)
ENVIRONMENTAL CONDITIONS	25deg. C, 65%RH	TESTED BY	Kay Wu

**ANTENNA POLARITY & TEST DISTANCE: HORIZONTAL AT 3 M**

FREQ. (MHz)	EMISSION LEVEL (dBuV/m)	READ LEVEL (dBuV)	LIMIT (dBuV/m)	MARGIN (dB)	ANTENNA FACTOR (dB/m)	CABLE LOSS (dB)	PREAMP FACTOR (dB)	ANTENNA HEIGHT (cm)	TABLE ANGLE (Degree)	REMARK
5725	48.86	39.7	78.59	-29.73	34.62	8.65	34.11	145	96	Average
5725	56.38	47.22	85.99	-29.61	34.62	8.65	34.11	145	96	Peak
5785	98.59	89.36			34.68	8.68	34.13	145	96	Average
5785	105.99	96.76			34.68	8.68	34.13	145	96	Peak
5825	48.99	39.7	78.59	-29.6	34.73	8.69	34.13	145	96	Average
5825	58.62	49.33	85.99	-27.37	34.73	8.69	34.13	145	96	Peak

**ANTENNA POLARITY & TEST DISTANCE: VERTICAL AT 3 M**

FREQ. (MHz)	EMISSION LEVEL (dBuV/m)	READ LEVEL (dBuV)	LIMIT (dBuV/m)	MARGIN (dB)	ANTENNA FACTOR (dB/m)	CABLE LOSS (dB)	PREAMP FACTOR (dB)	ANTENNA HEIGHT (cm)	TABLE ANGLE (Degree)	REMARK
5725	50.13	40.97	85.92	-35.79	34.62	8.65	34.11	125	126	Average
5725	57.47	48.31	93.73	-36.26	34.62	8.65	34.11	125	126	Peak
5785	105.92	96.69			34.68	8.68	34.13	125	126	Average
5785	113.73	104.5			34.68	8.68	34.13	125	126	Peak
5825	58.94	49.65	85.92	-26.98	34.73	8.69	34.13	125	126	Average
5825	69.21	59.92	93.73	-24.52	34.73	8.69	34.13	125	126	Peak

**REMARKS:**

- Emission Level = Read Level + Antenna Factor + Cable Loss - Preamp Factor  
Margin value = Emission level – Limit value
- 5785MHz: Fundamental frequency.
- 5725MHz & 5825MHz: Out of restricted band



A D T

EUT TEST CONDITION		MEASUREMENT DETAIL	
CHANNEL	Channel 161	FREQUENCY RANGE	1GHz ~ 40GHz
INPUT POWER	120Vac, 60 Hz	DETECTOR FUNCTION	Peak (PK) Average (AV)
ENVIRONMENTAL CONDITIONS	25deg. C, 65%RH	TESTED BY	Kay Wu

**ANTENNA POLARITY & TEST DISTANCE: HORIZONTAL AT 3 M**

FREQ. (MHz)	EMISSION LEVEL (dBuV/m)	READ LEVEL (dBuV)	LIMIT (dBuV/m)	MARGIN (dB)	ANTENNA FACTOR (dB/m)	CABLE LOSS (dB)	PREAMP FACTOR (dB)	ANTENNA HEIGHT (cm)	TABLE ANGLE (Degree)	REMARK
5725	48.84	39.68	77.25	-28.41	34.62	8.65	34.11	145	96	Average
5725	56.67	47.51	84.86	-28.19	34.62	8.65	34.11	145	96	Peak
5805	97.25	87.99			34.71	8.68	34.13	145	96	Average
5805	104.86	95.6			34.71	8.68	34.13	145	96	Peak
5825	66.77	57.48	77.25	-10.48	34.73	8.69	34.13	145	96	Average
5825	79.15	69.86	84.86	-5.71	34.73	8.69	34.13	145	96	Peak

**ANTENNA POLARITY & TEST DISTANCE: VERTICAL AT 3 M**

FREQ. (MHz)	EMISSION LEVEL (dBuV/m)	READ LEVEL (dBuV)	LIMIT (dBuV/m)	MARGIN (dB)	ANTENNA FACTOR (dB/m)	CABLE LOSS (dB)	PREAMP FACTOR (dB)	ANTENNA HEIGHT (cm)	TABLE ANGLE (Degree)	REMARK
5725	49.13	39.97	84.63	-35.5	34.62	8.65	34.11	125	126	Average
5725	58.5	49.34	92.34	-33.84	34.62	8.65	34.11	125	126	Peak
5805	104.63	95.37			34.71	8.68	34.13	125	126	Average
5805	112.34	103.08			34.71	8.68	34.13	125	126	Peak
5825	73.32	64.03	84.63	-11.31	34.73	8.69	34.13	125	126	Average
5825	88.86	79.57	92.34	-3.48	34.73	8.69	34.13	125	126	Peak

**REMARKS:**

- Emission Level = Read Level + Antenna Factor + Cable Loss - Preamp Factor  
Margin value = Emission level – Limit value
- 5805MHz: Fundamental frequency.
- 5725MHz & 5825MHz: Out of restricted band



A D T

**802.11n (40MHz)**

EUT TEST CONDITION		MEASUREMENT DETAIL	
CHANNEL	Channel 151	FREQUENCY RANGE	1GHz ~ 40GHz
INPUT POWER	120Vac, 60 Hz	DETECTOR FUNCTION	Peak (PK) Average (AV)
ENVIRONMENTAL CONDITIONS	25deg. C, 65%RH	TESTED BY	Kay Wu

**ANTENNA POLARITY & TEST DISTANCE: HORIZONTAL AT 3 M**

FREQ. (MHz)	EMISSION LEVEL (dBuV/m)	READ LEVEL (dBuV)	LIMIT (dBuV/m)	MARGIN (dB)	ANTENNA FACTOR (dB/m)	CABLE LOSS (dB)	PREAMP FACTOR (dB)	ANTENNA HEIGHT (cm)	TABLE ANGLE (Degree)	REMARK
5725	69.84	60.68	77.37	-7.53	34.62	8.65	34.11	145	96	Average
5725	76.87	67.71	84.43	-7.56	34.62	8.65	34.11	145	96	Peak
5755	97.37	88.16			34.66	8.66	34.11	145	96	Average
5755	104.43	95.22			34.66	8.66	34.11	145	96	Peak
5825	49.99	40.7	77.37	-27.38	34.73	8.69	34.13	145	96	Average
5825	55.8	46.51	84.43	-28.63	34.73	8.69	34.13	145	96	Peak

**ANTENNA POLARITY & TEST DISTANCE: VERTICAL AT 3 M**

FREQ. (MHz)	EMISSION LEVEL (dBuV/m)	READ LEVEL (dBuV)	LIMIT (dBuV/m)	MARGIN (dB)	ANTENNA FACTOR (dB/m)	CABLE LOSS (dB)	PREAMP FACTOR (dB)	ANTENNA HEIGHT (cm)	TABLE ANGLE (Degree)	REMARK
5725	78.89	69.73	83.55	-4.66	34.62	8.65	34.11	125	126	Average
5725	90.08	80.92	91.09	-1.01	34.62	8.65	34.11	125	126	Peak
5755	103.55	94.34			34.66	8.66	34.11	125	126	Average
5755	111.09	101.88			34.66	8.66	34.11	125	126	Peak
5825	51.99	42.7	83.55	-31.56	34.73	8.69	34.13	125	126	Average
5825	59.23	49.94	91.09	-31.86	34.73	8.69	34.13	125	126	Peak

**REMARKS:**

- Emission Level = Read Level + Antenna Factor + Cable Loss - Preamp Factor  
Margin value = Emission level – Limit value
- 5755MHz: Fundamental frequency.
- 5725MHz & 5825MHz: Out of restricted band



A D T

EUT TEST CONDITION		MEASUREMENT DETAIL	
CHANNEL	Channel 159	FREQUENCY RANGE	1GHz ~ 40GHz
INPUT POWER	120Vac, 60 Hz	DETECTOR FUNCTION	Peak (PK) Average (AV)
ENVIRONMENTAL CONDITIONS	25deg. C, 65%RH	TESTED BY	Kay Wu

**ANTENNA POLARITY & TEST DISTANCE: HORIZONTAL AT 3 M**

FREQ. (MHz)	EMISSION LEVEL (dBuV/m)	READ LEVEL (dBuV)	LIMIT (dBuV/m)	MARGIN (dB)	ANTENNA FACTOR (dB/m)	CABLE LOSS (dB)	PREAMP FACTOR (dB)	ANTENNA HEIGHT (cm)	TABLE ANGLE (Degree)	REMARK
5725	52.84	43.68	77.94	-25.1	34.62	8.65	34.11	145	96	Average
5725	58.6	49.44	84.47	-25.87	34.62	8.65	34.11	145	96	Peak
5795	97.94	88.7			34.69	8.68	34.13	145	96	Average
5795	104.47	95.23			34.69	8.68	34.13	145	96	Peak
5825	64.99	55.7	77.94	-12.95	34.73	8.69	34.13	145	96	Average
5825	74.63	65.34	84.47	-9.84	34.73	8.69	34.13	145	96	Peak

**ANTENNA POLARITY & TEST DISTANCE: VERTICAL AT 3 M**

FREQ. (MHz)	EMISSION LEVEL (dBuV/m)	READ LEVEL (dBuV)	LIMIT (dBuV/m)	MARGIN (dB)	ANTENNA FACTOR (dB/m)	CABLE LOSS (dB)	PREAMP FACTOR (dB)	ANTENNA HEIGHT (cm)	TABLE ANGLE (Degree)	REMARK
5725	53.84	44.68	83.94	-30.1	34.62	8.65	34.11	125	126	Average
5725	61.1	51.94	91.13	-30.03	34.62	8.65	34.11	125	126	Peak
5795	103.94	94.7			34.69	8.68	34.13	125	126	Average
5795	111.13	101.89			34.69	8.68	34.13	125	126	Peak
5825	79.28	69.99	83.94	-4.66	34.73	8.69	34.13	122	93	Average
5825	88.97	79.68	91.13	-2.16	34.73	8.69	34.13	122	93	Peak

**REMARKS:**

- Emission Level = Read Level + Antenna Factor + Cable Loss - Preamp Factor  
Margin value = Emission level – Limit value
- 5795MHz: Fundamental frequency.
- 5725MHz & 5825MHz: Out of restricted band



A D T

## **5.2 6dB BANDWIDTH MEASUREMENT**

### **5.2.1 LIMITS OF 6dB BANDWIDTH MEASUREMENT**

The minimum of 6dB Bandwidth Measurement is 0.5MHz.

### **5.2.2 TEST SETUP**

Same as section 4.2.2.

### **5.2.3 TEST INSTRUMENTS**

Refer to section 4.1.2 to get information of above instrument.

### **5.2.4 TEST PROCEDURE**

Same as section 4.2.4.

### **5.2.5 DEVIATION FROM TEST STANDARD**

No deviation.

### **5.2.6 EUT OPERATING CONDITIONS**

Same as section 4.2.6.





A D T

## 5.2.7 TEST RESULTS

### MODE A

#### 802.11a

CHANNEL	FREQUENCY (MHz)	6dB BANDWIDTH (MHz)	MINIMUM LIMIT (MHz)	PASS / FAIL
149	5745	15.97	0.5	PASS
157	5785	16.32	0.5	PASS
161	5805	16.31	0.5	PASS

#### 802.11n (20MHz)

CHANNEL	FREQUENCY (MHz)	6dB BANDWIDTH (MHz)	MINIMUM LIMIT (MHz)	PASS / FAIL
149	5745	17.04	0.5	PASS
157	5785	16.95	0.5	PASS
161	5805	16.79	0.5	PASS

#### 802.11n (40MHz)

CHANNEL	FREQUENCY (MHz)	6dB BANDWIDTH (MHz)	MINIMUM LIMIT (MHz)	PASS / FAIL
151	5755	35.10	0.5	PASS
159	5795	35.10	0.5	PASS



A D T

**MODE C**

**802.11n (20MHz)**

CHANNEL	FREQUENCY (MHz)	6dB BANDWIDTH (MHz)			MINIMUM LIMIT (MHz)	PASS / FAIL
		CHAIN 0	CHAIN 1	CHAIN 2		
149	5745	15.19	15.19	15.40	0.5	PASS
157	5785	15.42	15.19	15.17	0.5	PASS
161	5805	15.36	15.16	15.49	0.5	PASS

**802.11n (40MHz)**

CHANNEL	FREQUENCY (MHz)	6dB BANDWIDTH (MHz)			MINIMUM LIMIT (MHz)	PASS / FAIL
		CHAIN 0	CHAIN 1	CHAIN 2		
151	5755	33.91	33.87	35.12	0.5	PASS
159	5795	35.17	35.12	35.14	0.5	PASS

**SPECTRUM PLOT OF WORST VALUE**

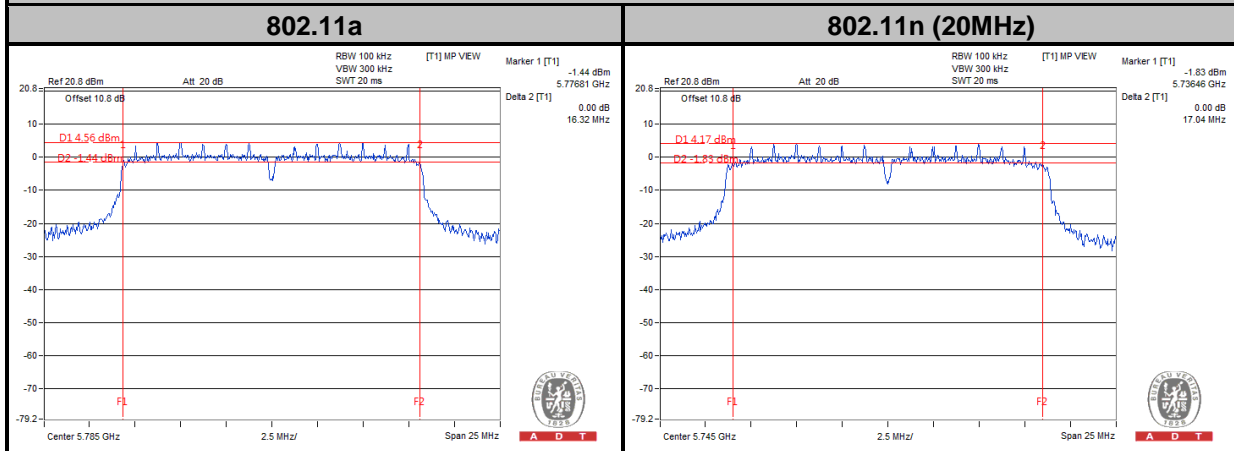

**802.11n (40MHz)**

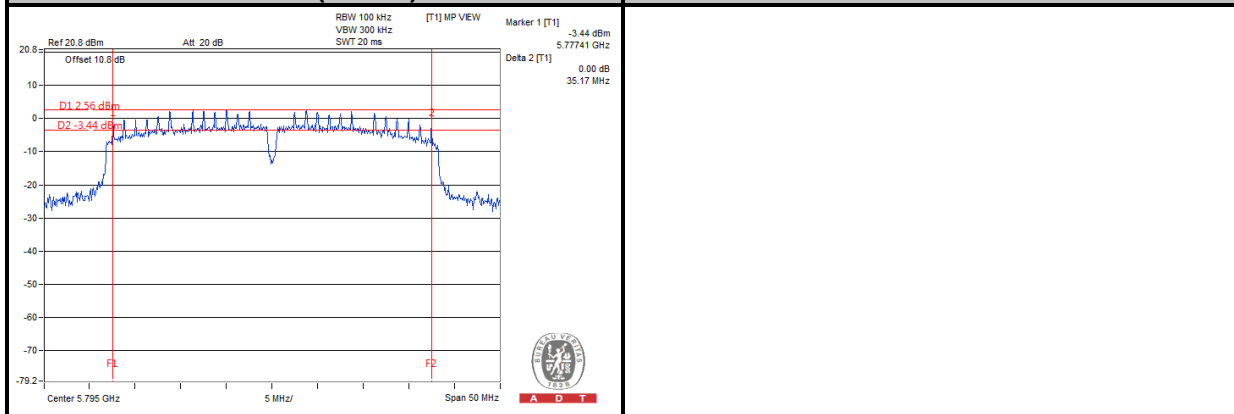

## **5.3 MAXIMUM OUTPUT POWER**

### **5.3.1 LIMITS OF MAXIMUM OUTPUT POWER MEASUREMENT**

For systems using digital modulation in the 5725–5850 MHz bands: 1 Watt (30dBm)

Per KDB 662911 D01 Multiple Transmitter Output v02r01 Method of conducted output power measurement on IEEE 802.11 devices,

Array Gain = 0 dB (i.e., no array gain) for  $NANT \leq 4$ ;

Array Gain = 0 dB (i.e., no array gain) for channel widths  $\geq 40$  MHz for any NANT;

Array Gain =  $5 \log(NANT/NSS)$  dB or 3 dB, whichever is less for 20-MHz channel widths with  $NANT \geq 5$ .

For power measurements on all other devices: Array Gain =  $10 \log(NANT/NSS)$  dB.

### **5.3.2 TEST SETUP**

Same as section 4.3.2.

### **5.3.3 INSTRUMENTS**

Refer to section 4.1.2 to get information of above instrument.

### **5.3.4 TEST PROCEDURES**

Same as section 4.3.4.

### **5.3.5 DEVIATION FROM TEST STANDARD**

No deviation.

### **5.3.6 EUT OPERATING CONDITIONS**

Same as section 4.2.6.

### 5.3.7 TEST RESULTS

#### MODE A

##### 802.11a

CHANNEL	FREQUENCY (MHz)	PEAK POWER (mW)	PEAK POWER (dBm)	LIMIT (dBm)	PASS / FAIL
149	5745	85.51	19.32	30	PASS
157	5785	90.99	19.59	30	PASS
161	5805	86.10	19.35	30	PASS

##### 802.11n (20MHz)

CHANNEL	FREQUENCY (MHz)	PEAK POWER (mW)	PEAK POWER (dBm)	LIMIT (dBm)	PASS / FAIL
149	5745	89.33	19.51	30	PASS
157	5785	92.26	19.65	30	PASS
161	5805	90.99	19.59	30	PASS

##### 802.11n (40MHz)

CHANNEL	FREQUENCY (MHz)	PEAK POWER (mW)	PEAK POWER (dBm)	LIMIT (dBm)	PASS / FAIL
151	5755	94.41	19.75	30	PASS
159	5795	94.84	19.77	30	PASS



A D T

### MODE B

#### 802.11n (20MHz)

CHAN.	FREQ. (MHz)	PEAK POWER (dBm)		TOTAL POWER (mW)	TOTAL POWER (dBm)	LIMIT (dBm)	PASS / FAIL
		CHAIN 0	CHAIN 1				
149	5745	16.87	15.54	84.450	19.27	30	PASS
157	5785	16.98	15.67	86.786	19.38	30	PASS
161	5805	16.86	15.67	85.427	19.32	30	PASS

#### 802.11n (40MHz)

CHAN.	FREQ. (MHz)	PEAK POWER (dBm)		TOTAL POWER (mW)	TOTAL POWER (dBm)	LIMIT (dBm)	PASS / FAIL
		CHAIN 0	CHAIN 1				
151	5755	16.45	15.92	83.241	19.20	30	PASS
159	5795	16.97	15.68	86.757	19.38	30	PASS

### MODE C

#### 802.11n (20MHz)

CHAN.	FREQ. (MHz)	PEAK POWER (dBm)			TOTAL POWER (mW)	TOTAL POWER (dBm)	LIMIT (dBm)	PASS / FAIL
		CHAIN 0	CHAIN 1	CHAIN 2				
149	5745	18.94	20.15	20.37	290.750	24.64	30	PASS
157	5785	18.85	20.59	20.22	296.484	24.72	30	PASS
161	5805	18.73	20.48	20.38	295.475	24.71	30	PASS

#### 802.11n (40MHz)

CHAN.	FREQ. (MHz)	PEAK POWER (dBm)			TOTAL POWER (mW)	TOTAL POWER (dBm)	LIMIT (dBm)	PASS / FAIL
		CHAIN 0	CHAIN 1	CHAIN 2				
151	5755	19.18	20.08	20.38	293.797	24.68	30	PASS
159	5795	18.69	20.44	20.45	295.540	24.71	30	PASS



A D T

## **5.4 POWER SPECTRAL DENSITY MEASUREMENT**

### **5.4.1 LIMITS OF POWER SPECTRAL DENSITY MEASUREMENT**

The Maximum of Power Spectral Density Measurement is 8dBm.

### **5.4.2 TEST SETUP**

Same as section 4.4.2.

### **5.4.3 TEST INSTRUMENTS**

Refer to section 4.1.2 to get information of above instrument.

### **5.4.4 TEST PROCEDURE.**

Same as section 4.4.4.

### **5.4.5 DEVIATION FROM TEST STANDARD**

No deviation.

### **5.4.6 EUT OPERATING CONDITION**

Same as section 4.2.6.



A D T

### 5.4.7 TEST RESULTS

#### MODE A

##### 802.11a

CHANNEL	FREQUENCY (MHz)	PSD (dBm/3kHz)	LIMIT (dBm/3kHz)	PASS / FAIL
149	5745	-11.64	8	PASS
157	5785	-9.75	8	PASS
161	5805	-9.81	8	PASS

##### 802.11n (20MHz)

CHANNEL	FREQUENCY (MHz)	PSD (dBm/3kHz)	LIMIT (dBm/3kHz)	PASS / FAIL
149	5745	-11.46	8	PASS
157	5785	-11.08	8	PASS
161	5805	-11.19	8	PASS

##### 802.11n (40MHz)

CHANNEL	FREQUENCY (MHz)	PSD (dBm/3kHz)	LIMIT (dBm/3kHz)	PASS / FAIL
151	5755	-11.37	8	PASS
159	5795	-11.06	8	PASS



**MODE C**

**802.11n (20MHz)**

TX Chain	Channel	Freq. (MHz)	PSD (dBm/3kHz)	10 log (N=3) dB	Total PSD (dBm/3kHz)	Limit (dBm/3kHz)	PASS /FAIL
0	149	5745	-10.55	4.77	-5.78	7.23	PASS
	157	5785	-11.28	4.77	-6.51	7.23	PASS
	161	5805	-11.58	4.77	-6.81	7.23	PASS
1	149	5745	-13.19	4.77	-8.42	7.23	PASS
	157	5785	-12.71	4.77	-7.94	7.23	PASS
	161	5805	-11.58	4.77	-6.81	7.23	PASS
2	149	5745	-12.40	4.77	-7.63	7.23	PASS
	157	5785	-12.48	4.77	-7.71	7.23	PASS
	165	5825	-11.97	4.77	-7.2	7.23	PASS

**NOTE:** Directional gain = 2dBi + 10log(3) = 6.77dBi > 6dBi , so the power density limit shall be reduced to 8-(6.77-6) = 7.23dBm.

**802.11n (40MHz)**

TX Chain	Channel	Freq. (MHz)	PSD (dBm/3kHz)	10 log (N=3) dB	Total PSD (dBm/3kHz)	Limit (dBm/3kHz)	PASS /FAIL
0	151	5755	-13.66	4.77	-8.89	7.23	PASS
	159	5795	-9.31	4.77	-4.54	7.23	PASS
1	151	5755	-15.31	4.77	-10.54	7.23	PASS
	159	5795	-13.94	4.77	-9.17	7.23	PASS
2	151	5755	-14.69	4.77	-9.92	7.23	PASS
	159	5795	-13.46	4.77	-8.69	7.23	PASS

**NOTE:** Directional gain = 2dBi + 10log(3) = 6.77dBi > 6dBi , so the power density limit shall be reduced to 8-(6.77-6) = 7.23dBm.





A D T

### SPECTRUM PLOT OF WORST VALUE

#### 802.11a

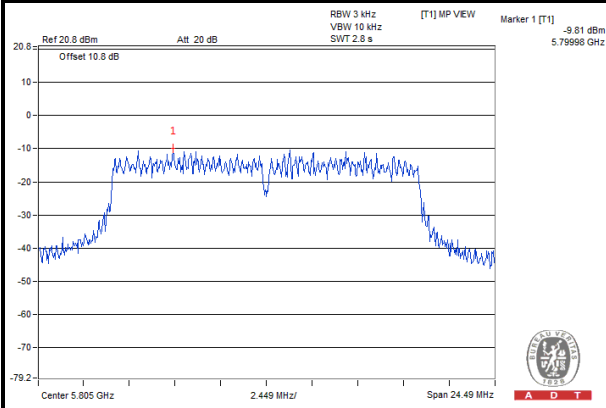

#### 802.11n (20MHz)

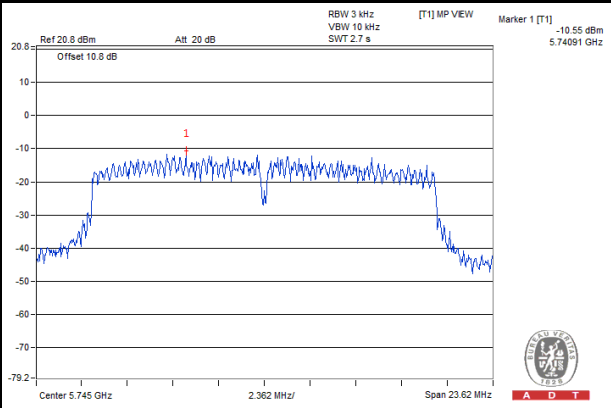

#### 802.11n (40MHz)

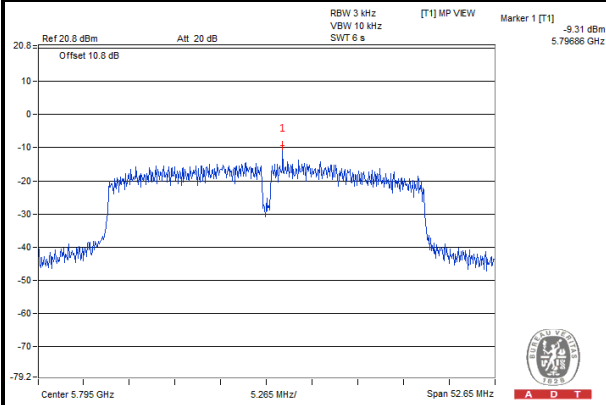

## **5.5 CONDUCTED OUT OF BAND EMISSION MEASUREMENT**

### **5.5.1 LIMITS OF OUT OF BAND EMISSION MEASUREMENT**

Below  $-20\text{dB}$  of the highest emission level of operating band (in 100kHz Resolution Bandwidth).

### **5.5.2 TEST SETUP**

Same as section 4.5.2.

### **5.5.3 TEST INSTRUMENTS**

Refer to section 4.1.2 to get information of above instrument.

### **5.5.4 TEST PROCEDURE**

Same as section 4.5.4

### **5.5.5 DEVIATION FROM TEST STANDARD**

No deviation.

### **5.5.6 EUT OPERATING CONDITION**

Same as section 4.2.6

### **5.5.7 TEST RESULTS**

The spectrum plots are attached on the following pages. D1 line indicates the highest level, and D2 line indicates the 20dB offset below D1. It shows compliance with the requirement.



A D T

MODE A

802.11a

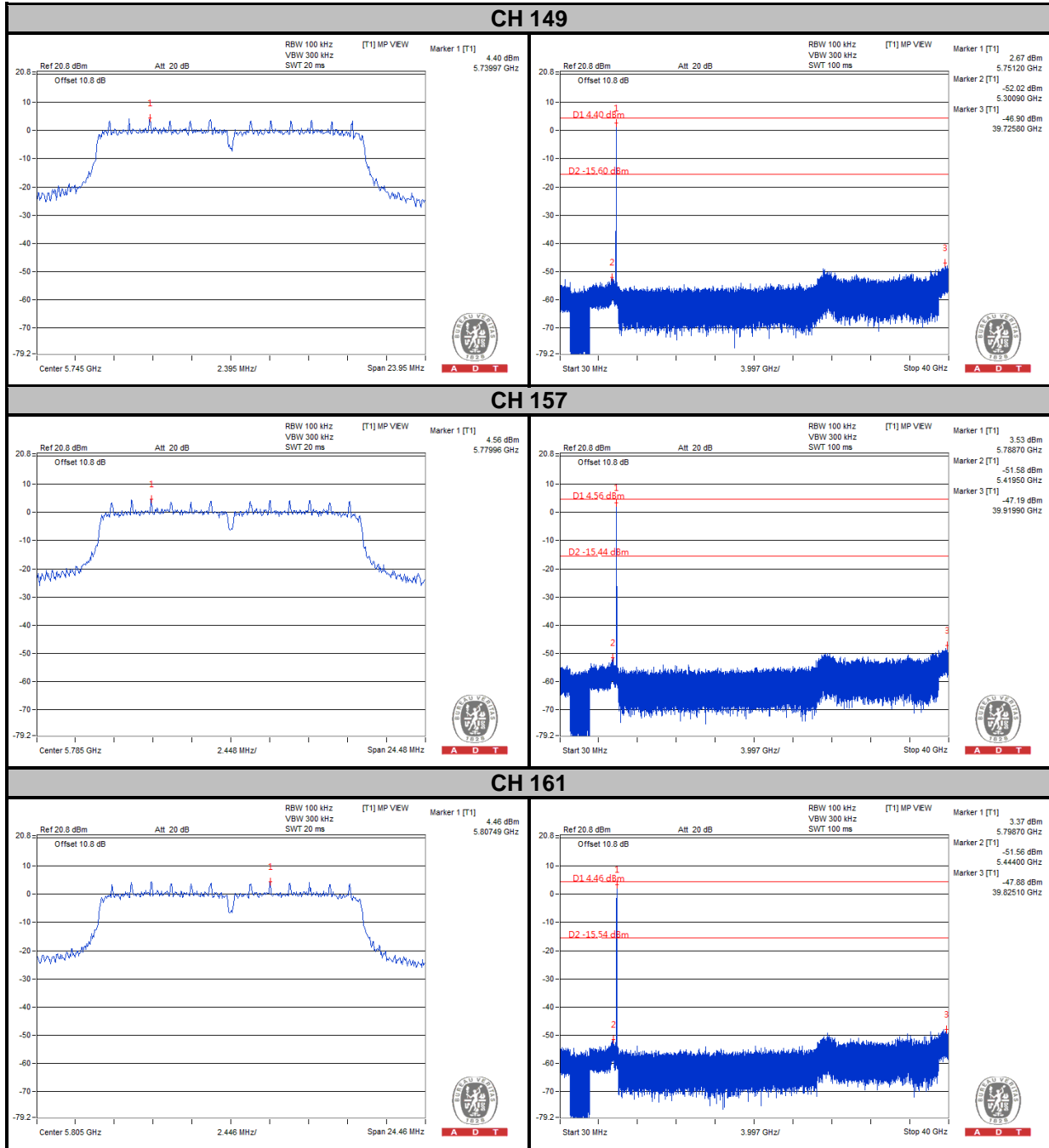



A D T

### 802.11n (20MHz)

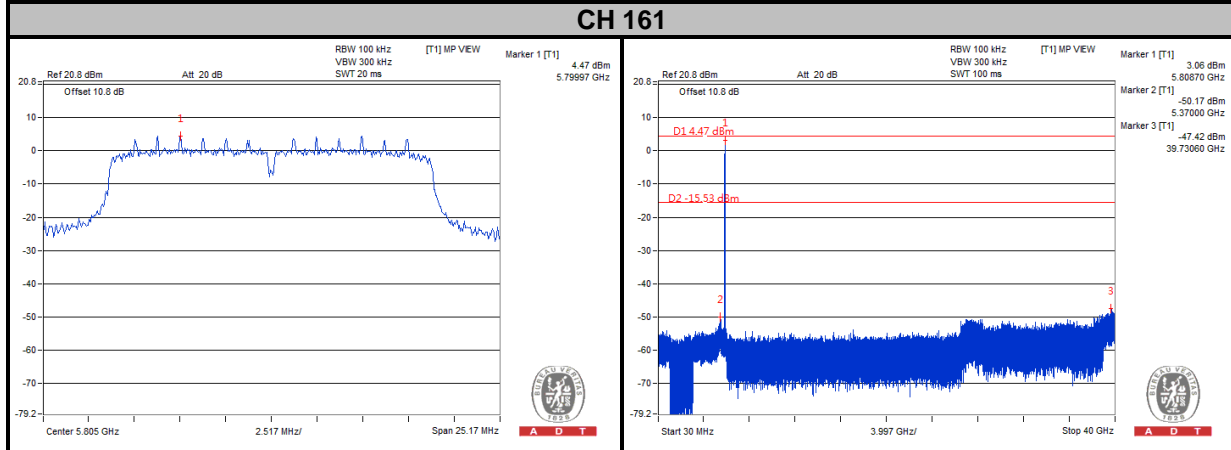
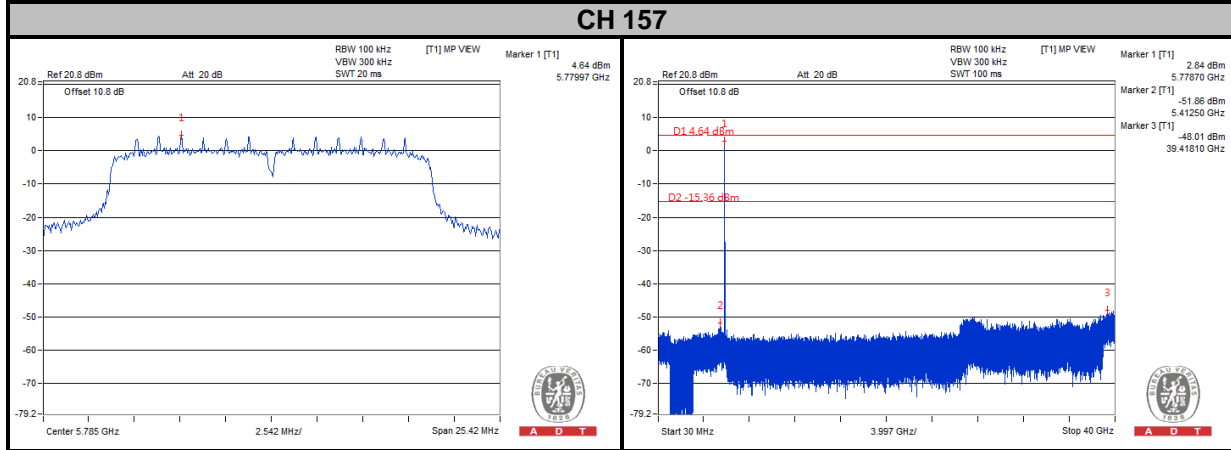
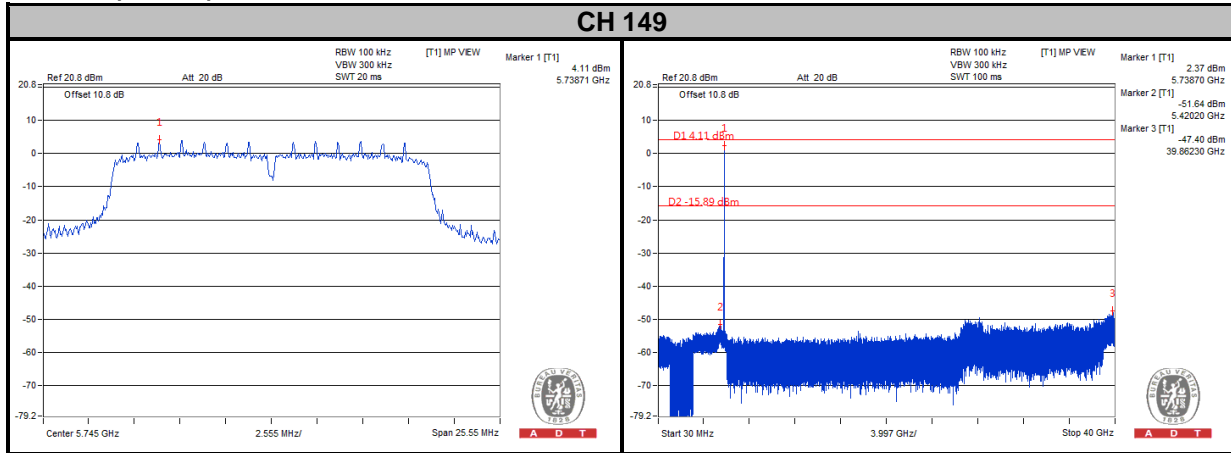



A D T

### 802.11n (40MHz)

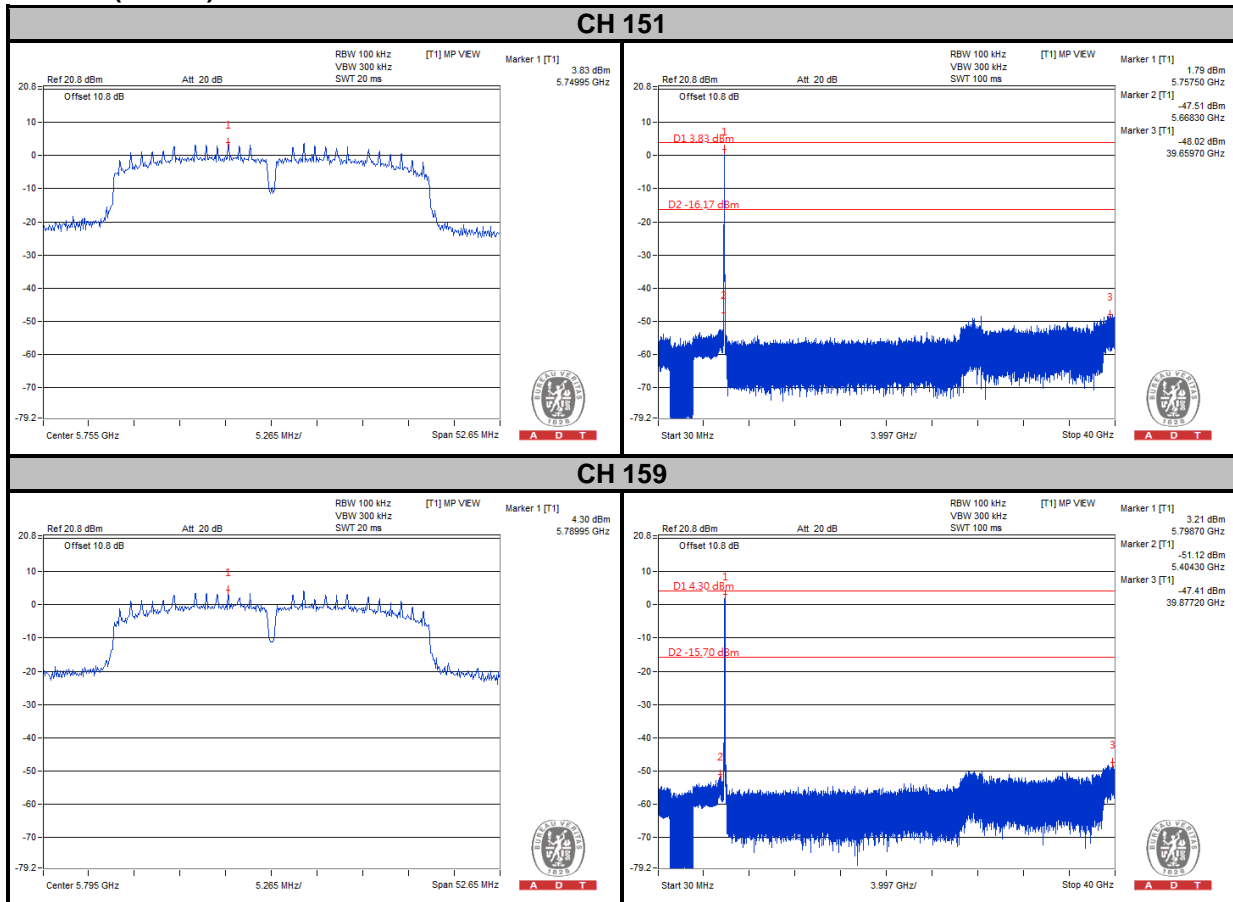



A D T

### MODE C

### 802.11n (20MHz)

### CHAIN 0

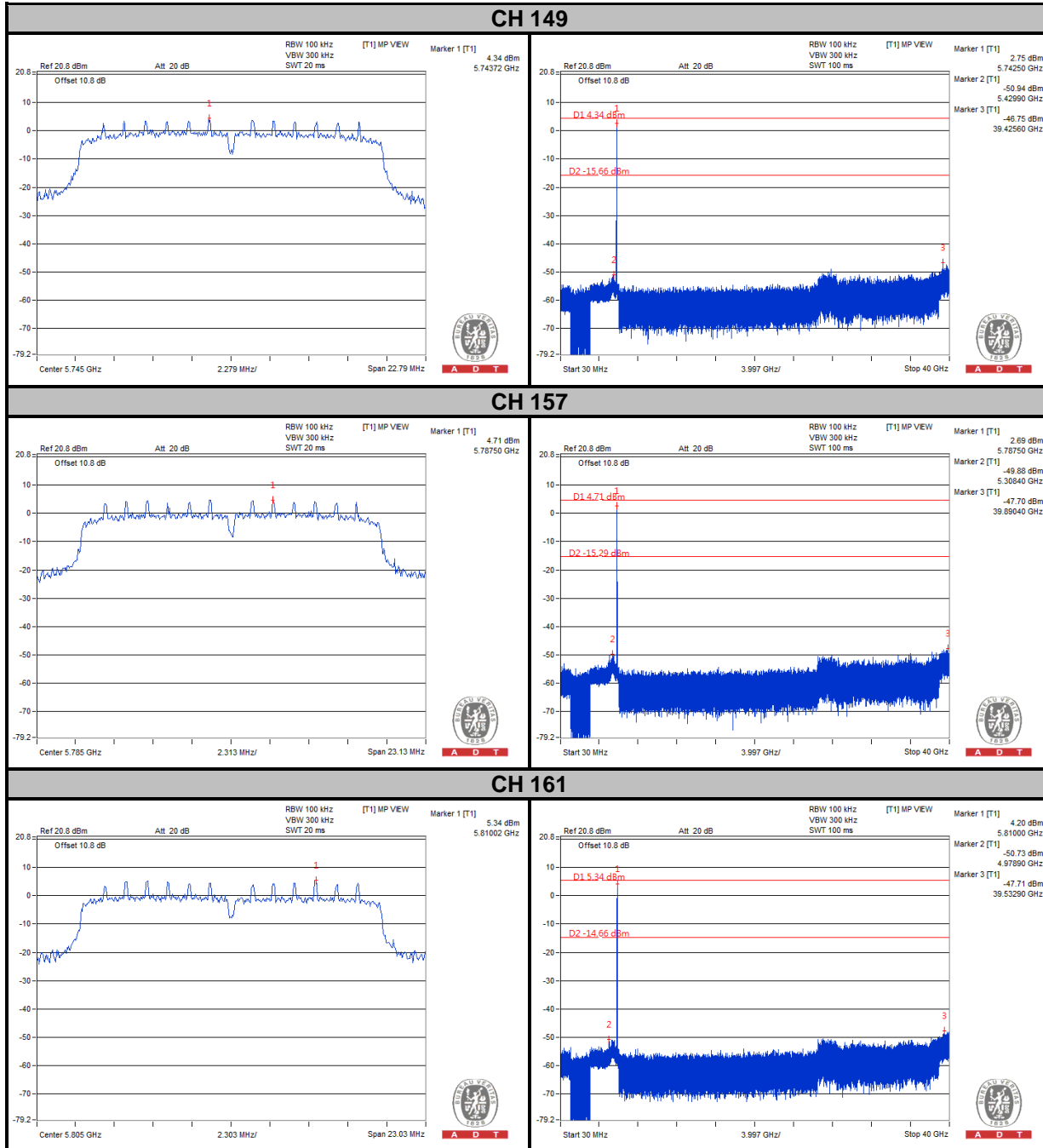



A D T

# CHAIN 1

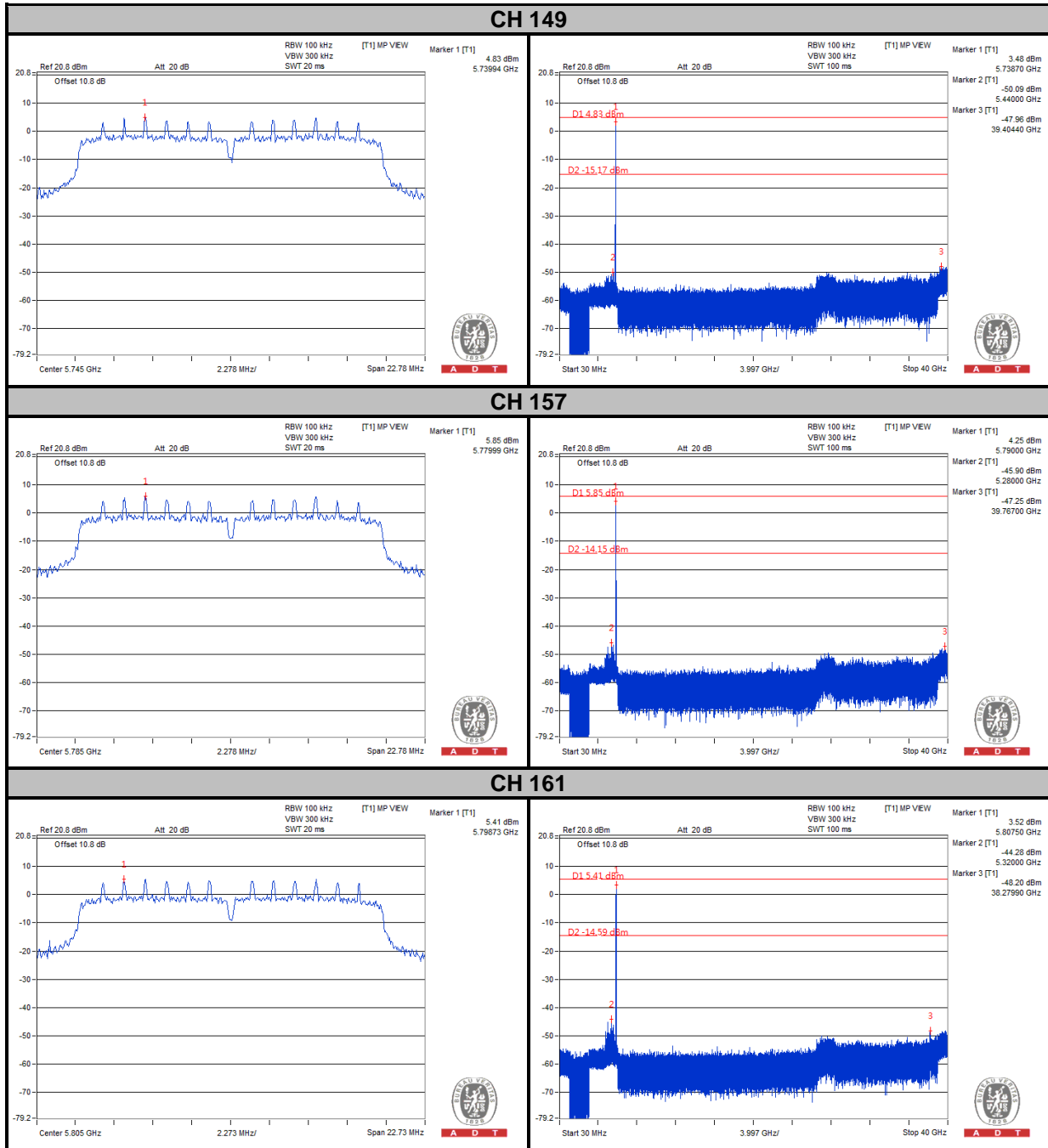



A D T

### CHAIN 2

#### CH 149

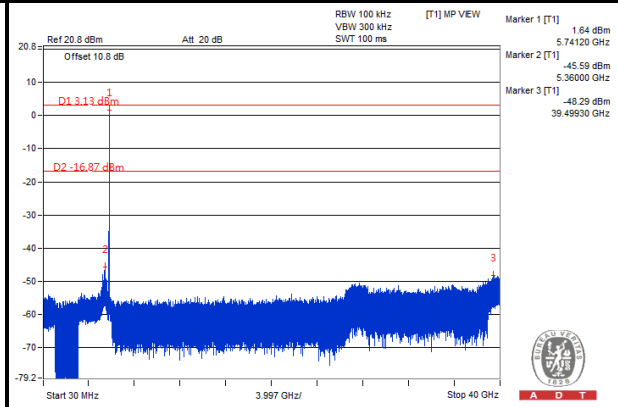
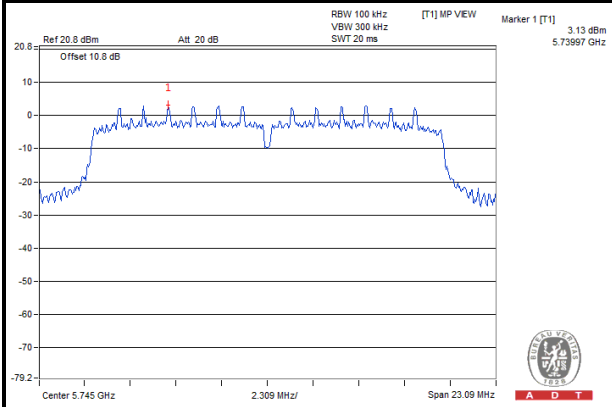

#### CH 157

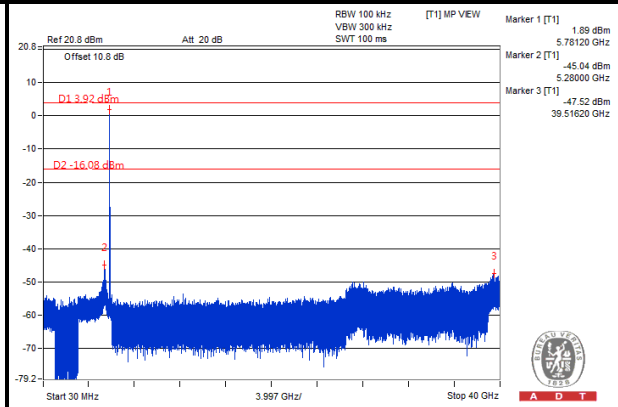
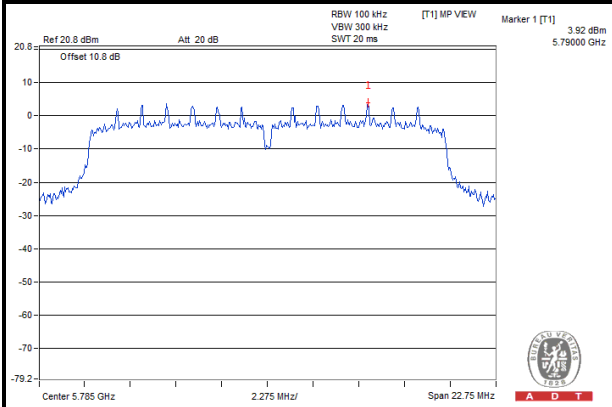

#### CH 161

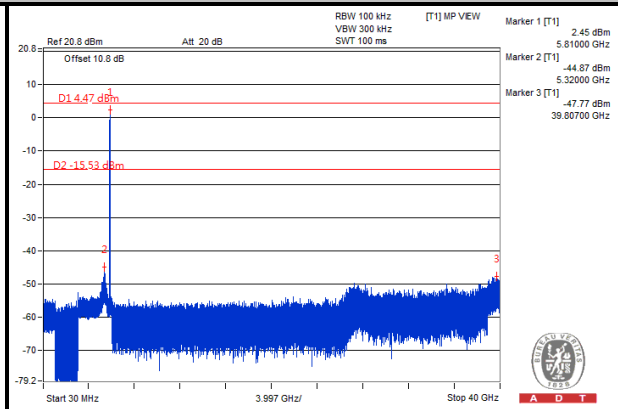
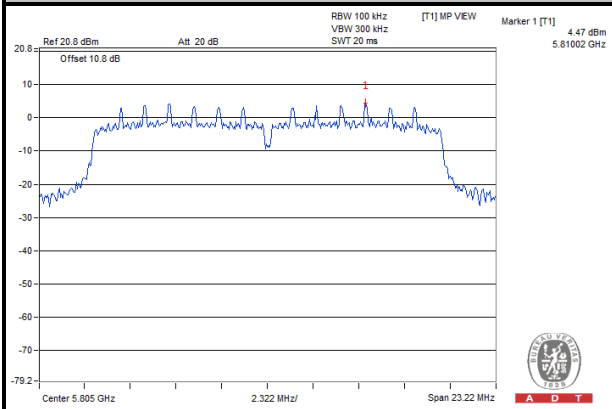





A D T

# 802.11n (40MHz)

## CHAIN 0

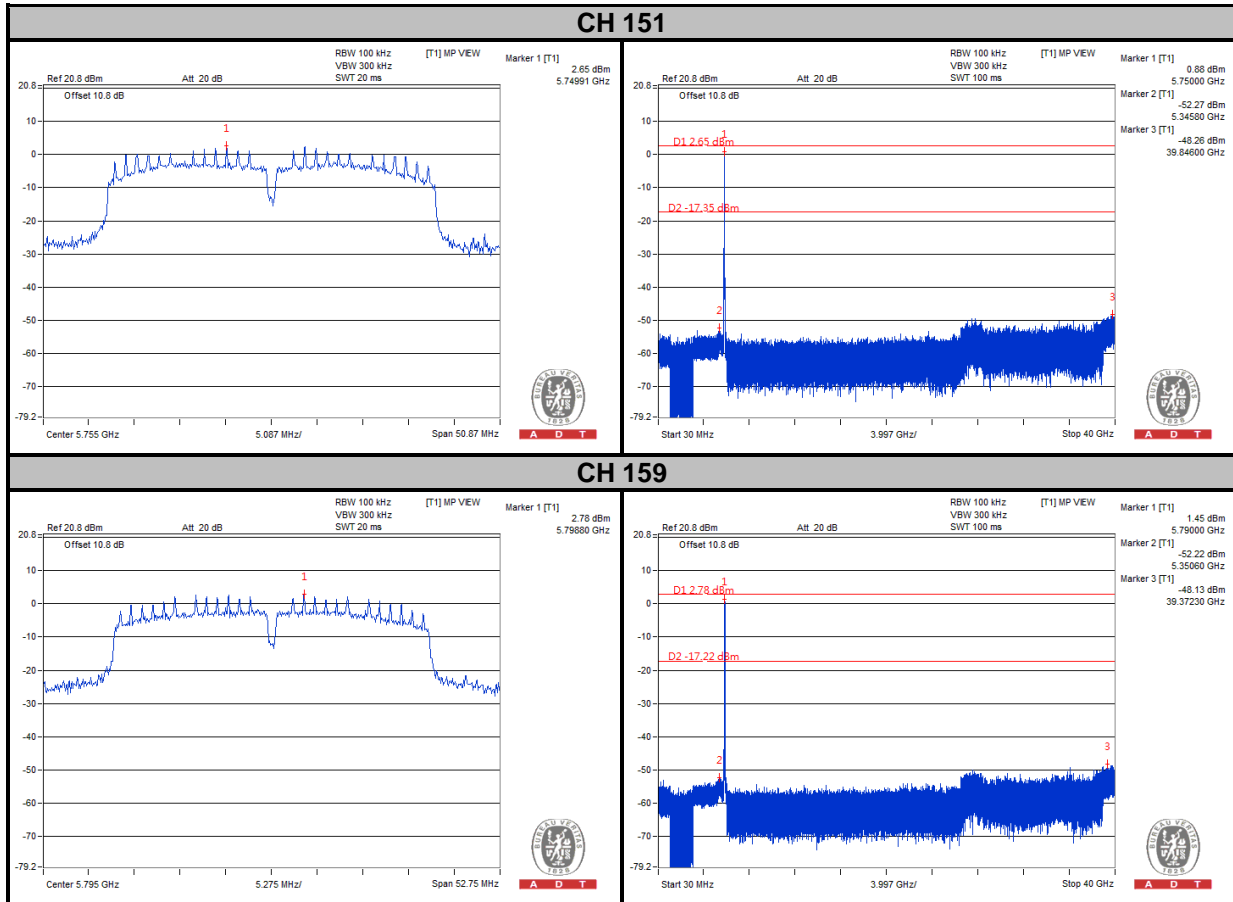



A D T

# CHAIN 1

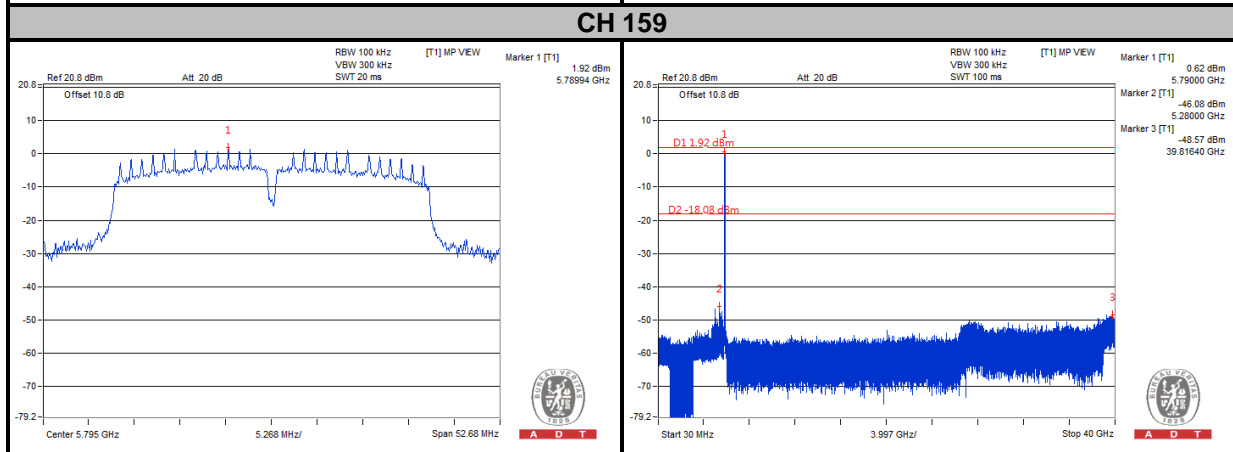
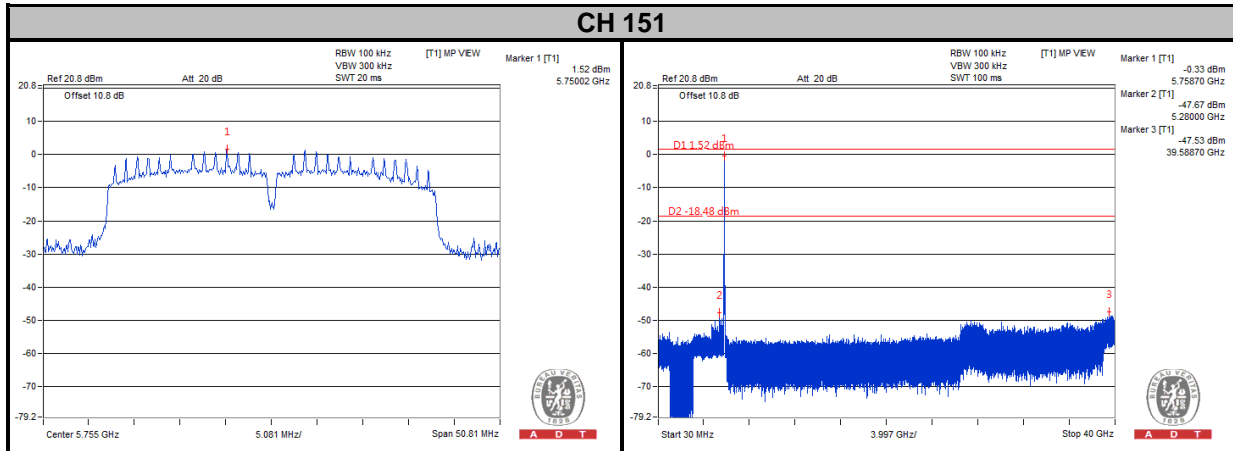



A D T

### CHAIN 2

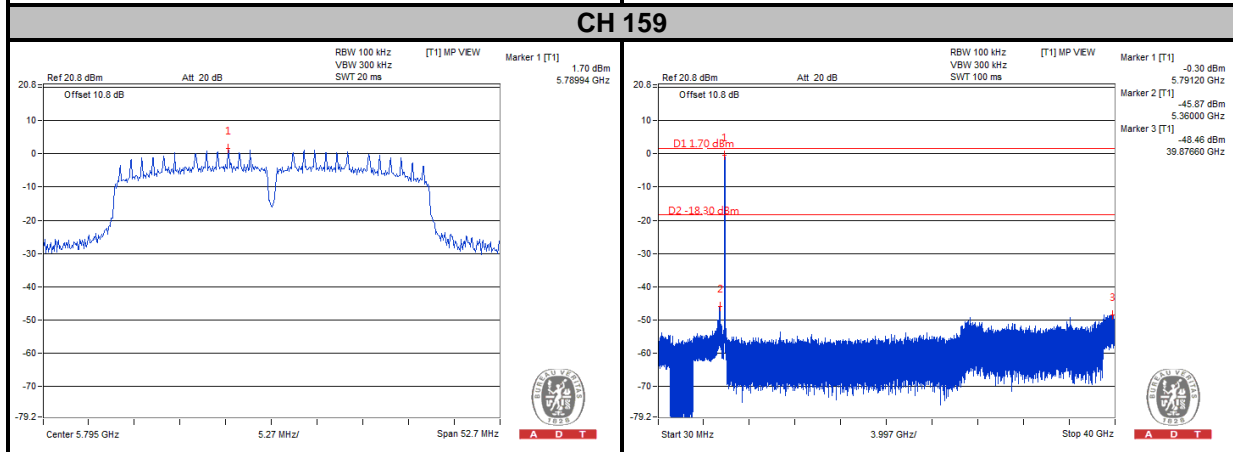
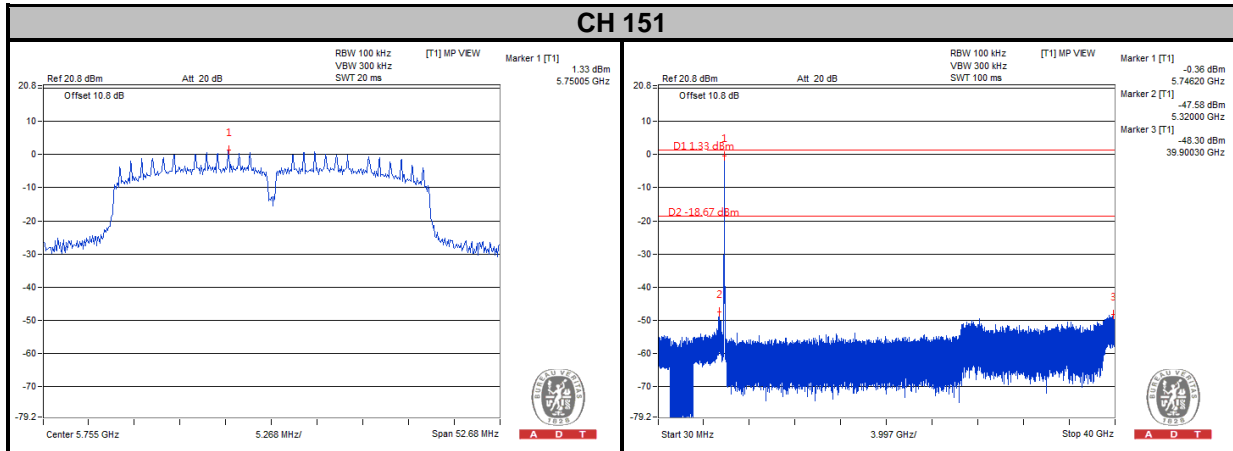



A D T

## 6. PHOTOGRAPHS OF THE TEST CONFIGURATION

Please refer to the attached file (Test Setup Photo).



## 7. INFORMATION ON THE TESTING LABORATORIES

We, Bureau Veritas Consumer Products Services (H.K.) Ltd., Taoyuan Branch, were founded in 1988 to provide our best service in EMC, Radio, Telecom and Safety consultation. Our laboratories are accredited and approved according to ISO/IEC 17025.

If you have any comments, please feel free to contact us at the following:

**Linko EMC/RF Lab:**

Tel: 886-2-26052180

Fax: 886-2-26051924

**Hsin Chu EMC/RF Lab:**

Tel: 886-3-5935343

Fax: 886-3-5935342

**Hwa Ya EMC/RF/Safety Telecom Lab:**

Tel: 886-3-3183232

Fax: 886-3-3270892

**Email:** [service.adt@tw.bureauveritas.com](mailto:service.adt@tw.bureauveritas.com)

**Web Site:** [www.bureauveritas-adt.com](http://www.bureauveritas-adt.com)

The address and road map of all our labs can be found in our web site also.



A D T

## 8. APPENDIX A – MODIFICATIONS RECORDERS FOR ENGINEERING CHANGES TO THE EUT BY THE LAB

No any modifications are made to the EUT by the lab during the test.

---END---