

Variant FCC Test Report

Report No.: RF170419C34A

FCC ID: W23-JWX5556

Test Model: JWX6055, JWX6056

Received Date: Apr. 19, 2017

Test Date: Jun. 09, 2017 ~ Jul. 03, 2017
May 14, 2018 ~ May 17, 2018

Issued Date: Jun. 05, 2018

Applicant: jjPlus CORP.

Address: 13F.-3, No.120, Qiaohe Rd., Zhonghe Dist., New Taipei City 23584, Taiwan
(R.O.C.)

Issued By: Bureau Veritas Consumer Products Services (H.K.) Ltd., Taoyuan Branch

Lab Address: No. 47-2, 14th Ling, Chia Pau Vil., Lin Kou Dist., New Taipei City, Taiwan
(R.O.C)

Test Location: No.19, Hwa Ya 2nd Rd., Wen Hwa Vil., Kwei Shan Dist., Taoyuan City
33383, TAIWAN (R.O.C.)

**FCC Registration /
Designation Number:** 788550 / TW0003



This report is for your exclusive use. Any copying or replication of this report to or for any other person or entity, or use of our name or trademark, is permitted only with our prior written permission. This report sets forth our findings solely with respect to the test samples identified herein. The results set forth in this report are not indicative or representative of the quality or characteristics of the lot from which a test sample was taken or any similar or identical product unless specifically and expressly noted. Our report includes all of the tests requested by you and the results thereof based upon the information that you provided to us. You have 60 days from date of issuance of this report to notify us of any material error or omission caused by our negligence, provided, however, that such notice shall be in writing and shall specifically address the issue you wish to raise. A failure to raise such issue within the prescribed time shall constitute your unqualified acceptance of the completeness of this report, the tests conducted and the correctness of the report contents. Unless specific mention, the uncertainty of measurement has been explicitly taken into account to declare the compliance or non-compliance to the specification. The report must not be used by the client to claim product certification, approval, or endorsement by TAF or any government agencies.

Table of Contents

Release Control Record	4
1 Certificate of Conformity	5
2 Summary of Test Results	6
2.1 Measurement Uncertainty	6
2.2 Modification Record.....	6
3 General Information	7
3.1 General Description of EUT	7
3.2 Description of Test Modes	9
3.2.1 Test Mode Applicability and Tested Channel Detail	11
3.3 Duty Cycle of Test Signal	13
3.4 Description of Support Units.....	14
3.4.1 Configuration of System under Test.....	14
3.5 General Description of Applied Standards	15
4 Test Types and Results	16
4.1 Radiated Emission and Bandedge Measurement	16
4.1.1 Limits of Radiated Emission and Bandedge Measurement	16
4.1.2 Limits of Unwanted Emission Out of the Restricted Bands	17
4.1.3 Test Instruments	18
4.1.4 Test Procedures.....	20
4.1.5 Deviation from Test Standard.....	21
4.1.6 Test Set Up	21
4.1.7 EUT Operating Conditions	22
4.1.8 Test Results	23
4.2 Conducted Emission Measurement	62
4.2.1 Limits of Conducted Emission Measurement	62
4.2.2 Test Instruments	62
4.2.3 Test Procedures.....	63
4.2.4 Deviation from Test Standard.....	63
4.2.5 Test Setup.....	63
4.2.6 EUT Operating Conditions	63
4.2.7 Test Results	64
4.3 Transmit Power Measurement	66
4.3.1 Limits of Transmit Power Measurement	66
4.3.2 Test Setup.....	66
4.3.3 Test Instruments	67
4.3.4 Test Procedure	67
4.3.5 Deviation from Test Standard.....	67
4.3.6 EUT Operating Conditions	67
4.3.7 Test Result	68
4.4 Occupied Bandwidth Measurement	75
4.4.1 Test Setup.....	75
4.4.2 Test Instruments	75
4.4.3 Test Procedure	75
4.4.4 Test Results	76
4.5 Peak Power Spectral Density Measurement.....	79
4.5.1 Limits of Peak Power Spectral Density Measurement	79
4.5.2 Test Setup.....	79
4.5.3 Test Instruments	79
4.5.4 Test Procedures.....	79
4.5.5 Deviation from Test Standard.....	80
4.5.6 EUT Operating Conditions	80
4.5.7 Test Results	81
4.6 Frequency Stability.....	86

4.6.1	Limit of Frequency Stability Measurement	86
4.6.2	Test Setup	86
4.6.3	Test Instruments	86
4.6.4	Test Procedure	86
4.6.5	Deviation from Test Standard	86
4.6.6	EUT Operating Condition	86
4.6.7	Test Results	87
4.7	6 dB Bandwidth Measurement	88
4.7.1	Limits of 6 dB Bandwidth Measurement.....	88
4.7.2	Test Setup	88
4.7.3	Test Instruments	88
4.7.4	Test Procedure	88
4.7.5	Deviation from Test Standard.....	88
4.7.6	EUT Operating Condition	88
4.7.7	Test Results	89
5	Pictures of Test Arrangements	91
	Annex A- Radiated Out of Band Emisison (OOBE) Measurement (For U-NII-3 band)	92
	Appendix – Information on the Testing Laboratories	95

Release Control Record

Issue No.	Description	Date Issued
RF170419C34A	Original Release	Jun. 05, 2018

1 Certificate of Conformity

Product: 802.11ac/abgn 2T2R Half Mini-PCI-Express Module

Brand: jjPlus

Test Model: JWX6055, JWX6056

Sample Status: Identical Prototype

Applicant: jjPlus CORP.

Test Date: Jun. 09, 2017 ~ Jul. 03, 2017

May 14, 2018 ~ May 17, 2018

Standards: 47 CFR FCC Part 15, Subpart E (Section 15.407)

ANSI C63.10:2013

The above equipment has been tested by **Bureau Veritas Consumer Products Services (H.K.) Ltd., Taoyuan Branch**, and found compliance with the requirement of the above standards. The test record, data evaluation & Equipment Under Test (EUT) configurations represented herein are true and accurate accounts of the measurements of the sample's RF characteristics under the conditions specified in this report.

Prepared by :

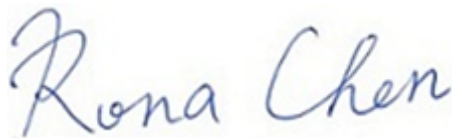

Date:

Jun. 05, 2018

Rona Chen / Specialist

Approved by :

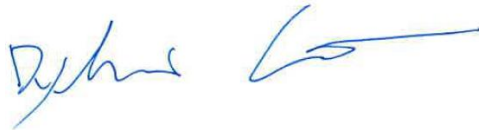

Date:

Jun. 05, 2018

Dylan Chiou / Project Engineer

2 Summary of Test Results

47 CFR FCC Part 15, Subpart E (Section 15.407)			
FCC Clause	Test Item	Result	Remarks
15.407(b)(6)	AC Power Conducted Emissions	Pass	Meet the requirement of limit. Minimum passing margin is -17.43 dB at 2.91000 MHz.
15.407(b) (1/2/3/4(iii)/6)	Radiated Emissions & Band Edge Measurement	Pass	Meet the requirement of limit. Minimum passing margin is -0.51 dB at 5725 MHz.
15.407(a)(1/2/3)	Max Average Transmit Power	Pass	Meet the requirement of limit.
---	Occupied Bandwidth Measurement	-	Reference only
15.407(a)(1/2/3)	Peak Power Spectral Density	Pass	Meet the requirement of limit.
15.407(e)	6 dB Bandwidth	Pass	Meet the requirement of limit. (U-NII-3 Band only)
15.407(g)	Frequency Stability	Pass	Meet the requirement of limit.
15.203	Antenna Requirement	Pass	No antenna connector is used.

*For U-NII-3 band compliance with rule part 15.407(b)(4)(i), the OOB test plots were recorded in Annex A.

2.1 Measurement Uncertainty

Where relevant, the following measurement uncertainty levels have been estimated for tests performed on the EUT as specified in CISPR 16-4-2:

Measurement	Frequency	Expanded Uncertainty (k=2) (±)
Conducted Emissions at mains ports	150 kHz ~ 30 MHz	2.44 dB
Radiated Emissions up to 1 GHz	30 MHz ~ 200 MHz	2.93 dB
	200 MHz ~ 1000 MHz	2.95 dB
Radiated Emissions above 1 GHz	1 GHz ~ 18 GHz	2.26 dB
	18 GHz ~ 40 GHz	1.94 dB

2.2 Modification Record

There were no modifications required for compliance.

3 General Information

3.1 General Description of EUT

Product	802.11ac/abgn 2T2R Half Mini-PCI-Express Module
Brand	jjPlus
Test Model	JWX6055, JW6056
Status of EUT	Identical Prototype
Power Supply Rating	3.3 Vdc (Host equipment)
Modulation Type	256QAM, 64QAM, 16QAM, QPSK, BPSK
Modulation Technology	OFDM
Transfer Rate	802.11a: 54.0/ 48.0/ 36.0/ 24.0/ 18.0/ 12.0/ 9.0/ 6.0 Mbps 802.11n: up to 300 Mbps 802.11ac: up to 866.7 Mbps
Operating Frequency	5180 ~ 5240 MHz, 5260 ~ 5320 MHz, 5500 ~ 5700 MHz, 5745 ~ 5825 MHz
Number of Channel	5180 ~ 5240 MHz: 4 for 802.11a, 802.11n (HT20) 2 for 802.11n (HT40) 1 for 802.11ac (VHT80) 5260 ~ 5320 MHz: 4 for 802.11a, 802.11n (HT20) 2 for 802.11n (HT40) 1 for 802.11ac (VHT80) 5500 ~ 5700 MHz: 11 for 802.11a, 802.11n (HT20) 5 for 802.11n (HT40) 2 for 802.11ac (VHT80) 5745 ~ 5825 MHz: 5 for 802.11a, 802.11n (HT20) 2 for 802.11n (HT40) 1 for 802.11ac (VHT80)
Output Power	167.314 mW for 5180 ~ 5240 MHz 152.398 mW for 5260 ~ 5320 MHz 155.279 mW for 5500 ~ 5700 MHz 167.593 mW for 5745 ~ 5825 MHz
Antenna Type	Dipole antenna with 2 dBi gain (5180 ~ 5240 MHz) Dipole antenna with 2 dBi gain (5260 ~ 5320 MHz) Dipole antenna with 2 dBi gain (5500 ~ 5700 MHz) Dipole antenna with 2 dBi gain (5745 ~ 5825 MHz)
Antenna Connector	N/A
Accessory Device	N/A
Data Cable Supplied	N/A

Note:

1. This report is issued as a supplementary report to BV CPS report no.: RF170419C34-1. The difference compared with original report is enabling bands from frequency 5.26 ~ 5.32 GHz and 5.50 ~ 5.70 GHz function.

2. The EUT incorporates a MIMO function. Physically, the EUT provides two completed transmitters and two receivers.

Modulation Mode	Tx Function
802.11a	1TX
802.11n (HT20)	2TX
802.11n (HT40)	2TX
802.11ac (VHT80)	2TX

3. All models are listed as below.

Brand	Model	Difference
jjPlus	JWX6055	The difference between two model names is temperature operating range only. Other specification is the same.
	JWX6056	

* JW X6056 was chosen for the final test and only its test result was recorded in this report.

4. The above EUT information is declared by manufacturer and for more detailed features description, please refer to the manufacturer's specifications or user's manual.

3.2 Description of Test Modes

For 5180 ~ 5240 MHz

4 channels are provided for 802.11a, 802.11n (HT20):

Channel	Frequency (MHz)	Channel	Frequency (MHz)
36	5180	44	5220
40	5200	48	5240

2 channels are provided for 802.11n (HT40):

Channel	Frequency (MHz)	Channel	Frequency (MHz)
38	5190	46	5230

1 channel is provided for 802.11ac (VHT80):

Channel	Frequency (MHz)
42	5210

For 5260 ~ 5320 MHz

4 channels are provided for 802.11a, 802.11n (HT20):

Channel	Frequency (MHz)	Channel	Frequency (MHz)
52	5260	60	5300
56	5280	64	5320

2 channels are provided for 802.11n (HT40):

Channel	Frequency (MHz)	Channel	Frequency (MHz)
54	5270	62	5310

1 channel is provided for 802.11ac (VHT80):

Channel	Frequency (MHz)
58	5290

For 5500 ~ 5700 MHz

11 channels are provided for 802.11a, 802.11n (HT20):

Channel	Frequency (MHz)	Channel	Frequency (MHz)
100	5500	124	5620
104	5520	128	5640
108	5540	132	5660
112	5560	136	5680
116	5580	140	5700
120	5600		

5 channels are provided for 802.11n (HT40):

Channel	Frequency (MHz)	Channel	Frequency (MHz)
102	5510	126	5630
110	5550	134	5670
118	5590		

2 channels are provided for 802.11ac (VHT80):

Channel	Frequency (MHz)	Channel	Frequency (MHz)
106	5530	122	5610

For 5745 ~ 5825 MHz:

5 channels are provided for 802.11a, 802.11n (HT20):

Channel	Frequency (MHz)	Channel	Frequency (MHz)
149	5745	161	5805
153	5765	165	5825
157	5785		

2 channels are provided for 802.11n (HT40):

Channel	Frequency (MHz)	Channel	Frequency (MHz)
151	5755	159	5795

1 channel is provided for 802.11ac (VHT80):

Channel	Frequency (MHz)
155	5775

3.2.1 Test Mode Applicability and Tested Channel Detail

EUT Configure Mode	Applicable To				Description
	RE \geq 1G	RE $<$ 1G	PLC	APCM	
-	√	√	√	√	-

Where **RE \geq 1G**: Radiated Emission above 1 GHz **RE $<$ 1G**: Radiated Emission below 1 GHz
PLC: Power Line Conducted Emission **APCM**: Antenna Port Conducted Measurement

Note:

1. The EUT had been pre-tested on the antenna positioned of X and Z plane. The worst case was found when positioned on **Z-plane**.
2. "-" means no effect.

Radiated Emission Test (Above 1 GHz):

- Pre-Scan has been conducted to determine the worst-case mode from all possible combinations between available modulations, data rates and antenna ports (if EUT with antenna diversity architecture).
- Following channel(s) was (were) selected for the final test as listed below.

EUT Configure Mode	Frequency Band (MHz)	Mode	Available Channel	Tested Channel	Modulation Technology	Modulation Type	Data Rate (Mbps)
-	5180-5240	802.11a	36 to 48	36, 44, 48	OFDM	BPSK	6.0
-		802.11n (HT20)	36 to 48	36, 44, 48	OFDM	BPSK	6.5
-		802.11n (HT40)	38 to 46	38, 46	OFDM	BPSK	13.5
-		802.11ac (VHT80)	42	42	OFDM	BPSK	29.3
-	5260-5320	802.11a	52 to 64	52, 60, 64	OFDM	BPSK	6.0
-		802.11n (HT20)	52 to 64	52, 60, 64	OFDM	BPSK	6.5
-		802.11n (HT40)	54 to 62	54, 62	OFDM	BPSK	13.5
-		802.11ac (VHT80)	58	58	OFDM	BPSK	29.3
-	5500-5700	802.11a	100 to 140	100, 116, 140	OFDM	BPSK	6.0
-		802.11n (HT20)	100 to 140	100, 116, 140	OFDM	BPSK	6.5
-		802.11n (HT40)	102 to 134	102, 110, 134	OFDM	BPSK	13.5
-		802.11ac (VHT80)	106 to 122	106, 122	OFDM	BPSK	29.3
-	5745-5825	802.11a	149 to 165	149, 157, 165	OFDM	BPSK	6.0
-		802.11n (HT20)	149 to 165	149, 157, 165	OFDM	BPSK	6.5
-		802.11n (HT40)	151 to 159	151, 159	OFDM	BPSK	13.5
-		802.11ac (VHT80)	155	155	OFDM	BPSK	29.3

Radiated Emission Test (Below 1 GHz):

- Pre-Scan has been conducted to determine the worst-case mode from all possible combinations between available modulations, data rates and antenna ports (if EUT with antenna diversity architecture).
- Following channel(s) was (were) selected for the final test as listed below.

EUT Configure Mode	Frequency Band (MHz)	Mode	Available Channel	Tested Channel	Modulation Technology	Modulation Type	Data Rate (Mbps)
-	5500-5700	802.11n (HT20)	100 to 140	140	OFDM	BPSK	6.5

Power Line Conducted Emission Test:

- Pre-Scan has been conducted to determine the worst-case mode from all possible combinations between available modulations, data rates and antenna ports (if EUT with antenna diversity architecture).
- Following channel(s) was (were) selected for the final test as listed below.

EUT Configure Mode	Frequency Band (MHz)	Mode	Available Channel	Tested Channel	Modulation Technology	Modulation Type	Data Rate (Mbps)
-	5180-5320	802.11n (HT20)	100 to 140	140	OFDM	BPSK	6.5

Antenna Port Conducted Measurement:

- This item includes all test value of each mode, but only includes spectrum plot of worst value of each mode.
- Pre-Scan has been conducted to determine the worst-case mode from all possible combinations between available modulations, data rates and antenna ports (if EUT with antenna diversity architecture).
- Following channel(s) was (were) selected for the final test as listed below.

EUT Configure Mode	Frequency Band (MHz)	Mode	Available Channel	Tested Channel	Modulation Technology	Modulation Type	Data Rate (Mbps)
-	5180-5240	802.11a	36 to 48	36, 44, 48	OFDM	BPSK	6.0
-		802.11n (HT20)	36 to 48	36, 44, 48	OFDM	BPSK	6.5
-		802.11n (HT40)	38 to 46	38, 46	OFDM	BPSK	13.5
-		802.11ac (VHT80)	42	42	OFDM	BPSK	29.3
-	5260-5320	802.11a	52 to 64	52, 60, 64	OFDM	BPSK	6.0
-		802.11n (HT20)	52 to 64	52, 60, 64	OFDM	BPSK	6.5
-		802.11n (HT40)	54 to 62	54, 62	OFDM	BPSK	13.5
-		802.11ac (VHT80)	58	58	OFDM	BPSK	29.3
-	5500-5700	802.11a	100 to 140	100, 116, 140	OFDM	BPSK	6.0
-		802.11n (HT20)	100 to 140	100, 116, 140	OFDM	BPSK	6.5
-		802.11n (HT40)	102 to 134	102, 110, 134	OFDM	BPSK	13.5
-		802.11ac (VHT80)	106 to 122	106, 122	OFDM	BPSK	29.3
-	5745-5825	802.11a	149 to 165	149, 157, 165	OFDM	BPSK	6.0
-		802.11n (HT20)	149 to 165	149, 157, 165	OFDM	BPSK	6.5
-		802.11n (HT40)	151 to 159	151, 159	OFDM	BPSK	13.5
-		802.11ac (VHT80)	155	155	OFDM	BPSK	29.3

Test Condition:

Applicable To	Environmental Conditions	Input Power	Tested by
RE≥1G	25 deg. C, 65 % RH	120 Vac, 60 Hz	Toby Tian / Jisyong Wang
RE<1G	25 deg. C, 65 % RH	120 Vac, 60 Hz	Jisyong Wang
PLC	25 deg. C, 65 % RH	120 Vac, 60 Hz	Getaz Yang
APCM	25 deg. C, 65 % RH	3.3 Vdc	Anson Lin / Wayne Lin

3.3 Duty Cycle of Test Signal

MODULATION TYPE: BPSK

802.11a: Duty cycle of test signal is > 98 %, duty factor is not required.

802.11n (HT20): Duty cycle of test signal is > 98 %, duty factor is not required.

802.11n (HT40): Duty cycle of test signal is > 98 %, duty factor is not required.

802.11ac (VHT80): Duty cycle of test signal is > 98 %, duty factor is not required.

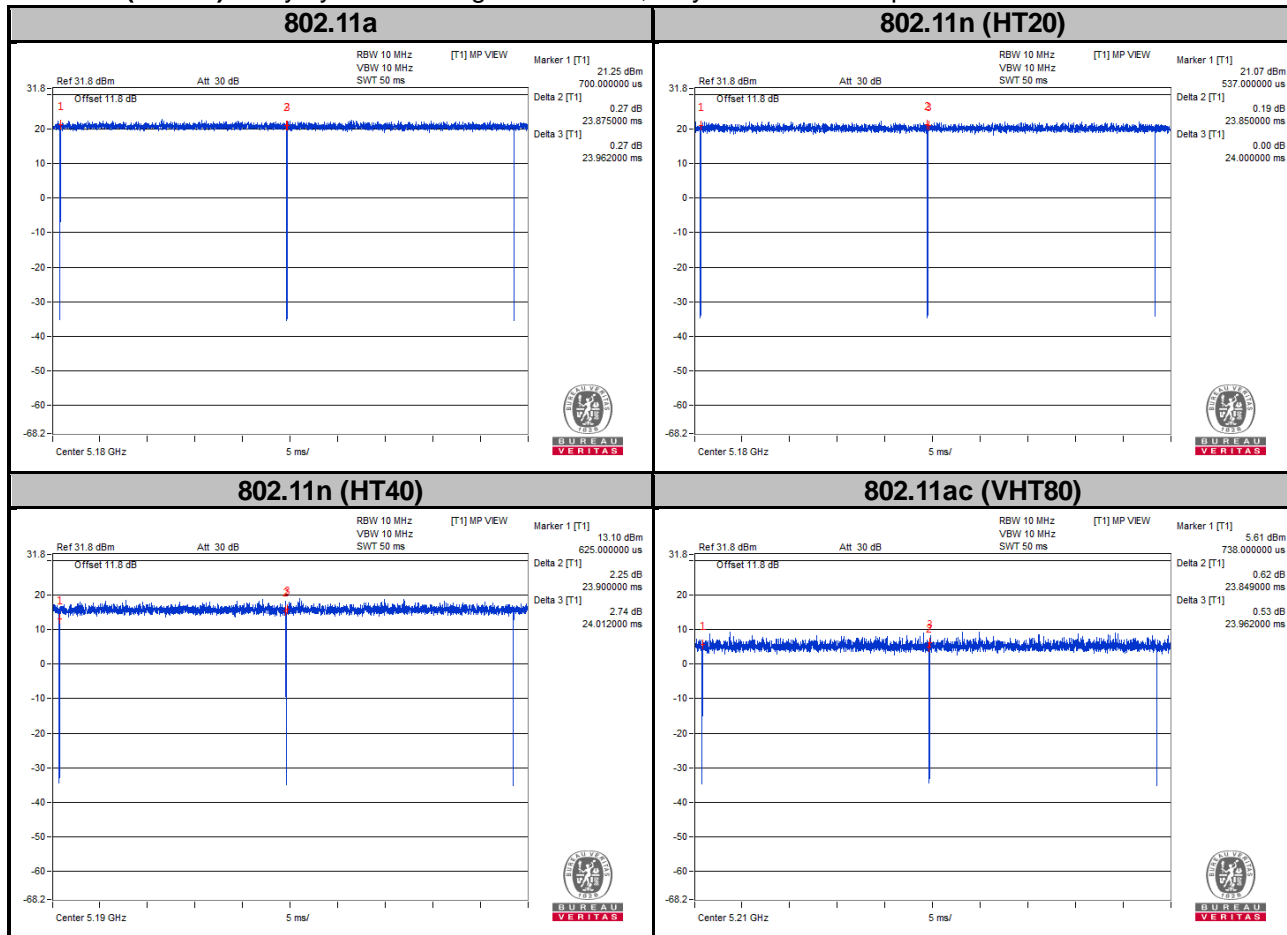

3.4 Description of Support Units

The EUT has been tested as an independent unit together with other necessary accessories or support units. The following support units or accessories were used to form a representative test configuration during the tests.

No.	Product	Brand	Model No.	Serial No.	FCC ID
1.	Notebook	DELL	E5420	33MJMQ1	N/A

No.	Signal Cable Description Of The Above Support Units
1.	N/A

Note:

1. All power cords of the above support units are non-shielded (1.8m).

3.4.1 Configuration of System under Test

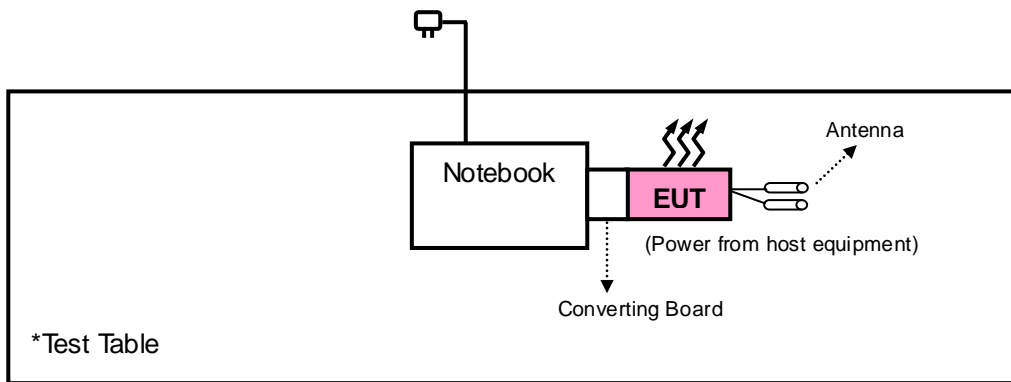

3.5 General Description of Applied Standards

The EUT is a RF Product. According to the specifications of the manufacturer, it must comply with the requirements of the following standards:

FCC Part 15, Subpart E (15.407)

KDB 789033 D02 General UNII Test Procedures New Rules v02r01

KDB 662911 D01 Multiple Transmitter Output v02r01

ANSI C63.10-2013

All test items have been performed and recorded as per the above standards.

4 Test Types and Results

4.1 Radiated Emission and Bandedge Measurement

4.1.1 Limits of Radiated Emission and Bandedge Measurement

Radiated emissions which fall in the restricted bands must comply with the radiated emission limits specified as below table. Other emissions shall be at least 20 dB below the highest level of the desired power:

Frequencies (MHz)	Field Strength (microvolts/meter)	Measurement Distance (meters)
0.009 ~ 0.490	2400/F (kHz)	300
0.490 ~ 1.705	24000/F (kHz)	30
1.705 ~ 30.0	30	30
30 ~ 88	100	3
88 ~ 216	150	3
216 ~ 960	200	3
Above 960	500	3

Note:

1. The lower limit shall apply at the transition frequencies.
2. Emission level (dBuV/m) = 20 log Emission level (uV/m).
3. For frequencies above 1000 MHz, the field strength limits are based on average detector, however, the peak field strength of any emission shall not exceed the maximum permitted average limits, specified above by more than 20 dB under any condition of modulation.

4.1.2 Limits of Unwanted Emission Out of the Restricted Bands

Applicable To		Limit	
789033 D02 General UNII Test Procedures New Rules v02r01		Field Strength at 3 m	
		PK: 74 (dBµV/m)	AV: 54 (dBµV/m)
Frequency Band	Applicable To	EIRP Limit	Equivalent Field Strength at 3 m
5150~5250 MHz	15.407(b)(1)	PK: -27 (dBm/MHz)	PK: 68.2 (dBµV/m)
5250~5350 MHz	15.407(b)(2)		
5470~5725 MHz	15.407(b)(3)		
5725~5850 MHz	15.407(b)(4)(i)	PK:-27 (dBm/MHz) ^{*1} PK:10 (dBm/MHz) ^{*2} PK:15.6 (dBm/MHz) ^{*3} PK:27 (dBm/MHz) ^{*4}	PK: 68.2 (dBµV/m) ^{*1} PK:105.2 (dBµV/m) ^{*2} PK: 110.8 (dBµV/m) ^{*3} PK:122.2 (dBµV/m) ^{*4}
	15.407(b)(4)(ii)	Emission limits in section 15.247(d)	

^{*1} beyond 75 MHz or more above of the band edge.

^{*2} below the band edge increasing linearly to 10 dBm/MHz at 25 MHz above.

^{*3} below the band edge increasing linearly to a level of 15.6 dBm/MHz at 5 MHz above.

^{*4} from 5 MHz above or below the band edge increasing linearly to a level of 27 dBm/MHz at the band edge.

Note:

The following formula is used to convert the equipment isotropic radiated power (eirp) to field strength:

$$E = \frac{1000000\sqrt{30P}}{3} \mu\text{V/m, where } P \text{ is the eirp (Watts).}$$

4.1.3 Test Instruments

Test Duration: Jun. 09, 2017 ~ Jul. 03, 2017

Description & Manufacturer	Model No.	Serial No.	Date of Calibration	Due Date of Calibration
Test Receiver Agilent	N9038A	MY51210203	Feb. 17, 2017	Feb. 16, 2018
Spectrum Analyzer Agilent	N9010A	MY52220314	Dec. 16, 2016	Dec. 15, 2017
Spectrum Analyzer ROHDE & SCHWARZ	FSU43	101261	Dec. 13, 2016	Dec. 12, 2017
BILOG Antenna SCHWARZBECK	VULB9168	9168-472	Dec. 26, 2016	Dec. 27, 2017
HORN Antenna SCHWARZBECK	BBHA 9120 D	9120D-969	Dec. 12, 2016	Dec. 13, 2017
HORN Antenna SCHWARZBECK	BBHA 9170	9170-480	Dec. 14, 2016	Dec. 13, 2017
Fixed Attenuator Mini-Circuits	BW-N10W5+	NA	Jul. 08, 2016	Jul. 07, 2017
Loop Antenna	EM-6879	269	Aug. 11, 2016	Aug. 10, 2017
Preamplifier EMCI	EMC 012645	980115	Oct. 21, 2016	Oct. 20, 2017
Preamplifier EMCI	EMC 184045	980116	Oct. 21, 2016	Oct. 20, 2017
Preamplifier EMCI	EMC 330H	980112	Oct. 21, 2016	Oct. 20, 2017
Power Meter Anritsu	ML2495A	1232002	Sep. 08, 2016	Sep. 07, 2017
Power Sensor Anritsu	MA2411B	1207325	Sep. 08, 2016	Sep. 07, 2017
RF signal cable HUBER+SUHNNER	SUCOFLEX 104	309219/4 2950114	Oct. 21, 2016	Oct. 20, 2017
RF signal cable HUBER+SUHNNER	SUCOFLEX 104	250130/4	Oct. 21, 2016	Oct. 20, 2017
RF Coaxial Cable Worken	8D-FB	Cable-Ch10-01	Oct. 21, 2016	Oct. 20, 2017
Software BV ADT	E3 6.120103	NA	NA	NA
Antenna Tower MF	MFA-440H	NA	NA	NA
Turn Table MF	MFT-201SS	NA	NA	NA
Antenna Tower & Turn Table Controller MF	MF-7802	NA	NA	NA
Temperature & Humidity Chamber	GTH-120-40-CP-AR	MAA1306-019	Sep. 02, 2016	Sep. 01, 2017
DC Power Supply Topward	33010D	807748	Oct. 25, 2016	Oct. 24, 2018
Digital Multimeter Fluke	87-III	70360742	Jul. 01, 2016 Jun. 30, 2017	Jun. 30, 2017 May 31, 2018

- Note:
1. The calibration interval of the above test instruments is 12 months and the calibrations are traceable to NML/ROC and NIST/USA.
 2. The test was performed in HwaYa Chamber 10.
 3. The horn antenna and preamplifier (model: EMC 184045) are used only for the measurement of emission frequency above 1 GHz if tested.
 4. The IC Site Registration No. is IC7450F-10.

Test Duration: May 14, 2018 ~ May 17, 2018

Description & Manufacturer	Model No.	Serial No.	Date of Calibration	Due Date of Calibration
Test Receiver Agilent	N9038A	MY51210203	Mar. 16, 2018	Mar. 15, 2019
Spectrum Analyzer Agilent	N9010A	MY52220314	Nov. 24, 2017	Nov. 23, 2018
Spectrum Analyzer ROHDE & SCHWARZ	FSU43	101261	Jan. 11, 2018	Jan. 10, 2019
Double Ridge Guide Horn Antenna EMCO	3115	5619	Nov. 30, 2017	Nov. 29, 2018
BILOG Antenna SCHWARZBECK	VULB 9168	9168-153	Dec. 06, 2017	Dec. 05, 2018
Fixed Attenuator Mini-Circuits	BW-N10W5+	1301	Aug. 14, 2017	Aug. 13, 2018
Loop Antenna	EM-6879	269	Aug. 11, 2017	Aug. 10, 2018
Preamplifier EMCI	EMC001340	980201	Nov. 01, 2017	Oct. 30, 2018
Preamplifier EMCI	EMC 012645	980115	Oct. 20, 2017	Oct. 19, 2018
Preamplifier EMCI	EMC 184045	980116	Oct. 20, 2017	Oct. 19, 2018
Preamplifier EMCI	EMC 330H	980112	Oct. 13, 2017	Oct. 12, 2018
Power Meter Anritsu	ML2495A	1012010	Aug. 15, 2017	Aug. 14, 2018
Power Sensor Anritsu	MA2411B	1315050	Aug. 15, 2017	Aug. 14, 2018
RF Coaxial Cable HUBER+SUHNNER	EMC104-SM-SM-800 0&3000	140811+170717	Oct. 20, 2017	Oct. 19, 2018
RF Coaxial Cable HUBER+SUHNNER	SUCOFLEX 104	EMC104-SM-SM-1 000(140807)	Oct. 20, 2017	Oct. 19, 2018
RF Coaxial Cable Worken	8D-FB	Cable-Ch10-01	Oct. 20, 2017	Oct. 19, 2018
Software BV ADT	E3 6.120103	NA	NA	NA
Antenna Tower MF	MFA-440H	NA	NA	NA
Turn Table MF	MFT-201SS	NA	NA	NA
Antenna Tower & Turn Table Controller MF	MF-7802	NA	NA	NA
Temperature & Humidity Chamber	GTH-120-40-CP-AR	MAA1306-019	Sep. 08, 2017	Sep. 07, 2018
DC Power Supply Topward	33010D	807748	Oct. 25, 2016	Oct. 24, 2018
Digital Multimeter Fluke	87-III	70360742	Jun. 30, 2017	Jun. 29, 2018

- Note:**
1. The calibration interval of the above test instruments is 12 / 24 months and the calibrations are traceable to NML/ROC and NIST/USA.
 2. The test was performed in HwaYa Chamber 10.
 3. The horn antenna and preamplifier (model: EMC 184045) are used only for the measurement of emission frequency above 1 GHz if tested.
 4. The IC Site Registration No. is IC7450F-10.

4.1.4 Test Procedures

For Radiated emission below 30 MHz

- a. The EUT was placed on the top of a rotating table 0.8 meters above the ground at a 3 meter chamber room. The table was rotated 360 degrees to determine the position of the highest radiation.
- b. The EUT was set 3 meters away from the interference-receiving antenna, which was mounted on the top of a variable-height antenna tower.
- c. Both Parallel, perpendicular, and ground-parallel orientations of the antenna are set to make the measurement.
- d. For each suspected emission, the EUT was arranged to its worst case and the rotatable table was turned from 0 degrees to 360 degrees to find the maximum reading.
- e. The test-receiver system was set to Quasi-Peak Detect Function and Specified Bandwidth with Maximum Hold Mode.

Note:

1. The resolution bandwidth and video bandwidth of test receiver/spectrum analyzer is 9 kHz at frequency below 30 MHz.

For Radiated emission above 30 MHz

- a. The EUT was placed on the top of a rotating table 0.8 meters (for 30 MHz ~ 1 GHz) / 1.5 meters (for above 1 GHz) above the ground at 3 meter chamber room for test. The table was rotated 360 degrees to determine the position of the highest radiation.
- b. The EUT was set 3 meters away from the interference-receiving antenna, which was mounted on the top of a variable-height antenna tower.
- c. The height of antenna is varied from one meter to four meters above the ground to determine the maximum value of the field strength. Both horizontal and vertical polarizations of the antenna are set to make the measurement.
- d. For each suspected emission, the EUT was arranged to its worst case and then the antenna was tuned to heights from 1 meter to 4 meters and the rotatable table was turned from 0 degrees to 360 degrees to find the maximum reading.
- e. The test-receiver system was set to quasi-peak detect function and specified bandwidth with maximum hold mode when the test frequency is below 1 GHz.
- f. The test-receiver system was set to peak and average detected function and specified bandwidth with maximum hold mode when the test frequency is above 1 GHz. If the peak reading value also meets average limit, measurement with the average detector is unnecessary.

Note:

1. The resolution bandwidth and video bandwidth of test receiver/spectrum analyzer is 120 kHz for Quasi-peak detection (QP) at frequency below 1 GHz.
2. The resolution bandwidth of test receiver/spectrum analyzer is 1 MHz and the video bandwidth is 3 MHz for Peak detection (PK) at frequency above 1 GHz.
3. The resolution bandwidth of test receiver/spectrum analyzer is 1 MHz and the video bandwidth is $\geq 1/T$ (Duty cycle < 98 %) or 10 Hz (Duty cycle \geq 98 %) for Average detection (AV) at frequency above 1 GHz.
(11a: RBW = 1 MHz, VBW = 100 Hz ; 11n (HT20): RBW = 1 MHz, VBW = 100 Hz ;
11n (HT40): RBW = 1 MHz, VBW = 100 Hz ; 11ac (VHT80): RBW = 1 MHz, VBW = 100 Hz)
4. All modes of operation were investigated and the worst-case emissions are reported.

4.1.5 Deviation from Test Standard

No deviation.

4.1.6 Test Set Up

<Radiated Emission below 30 MHz>

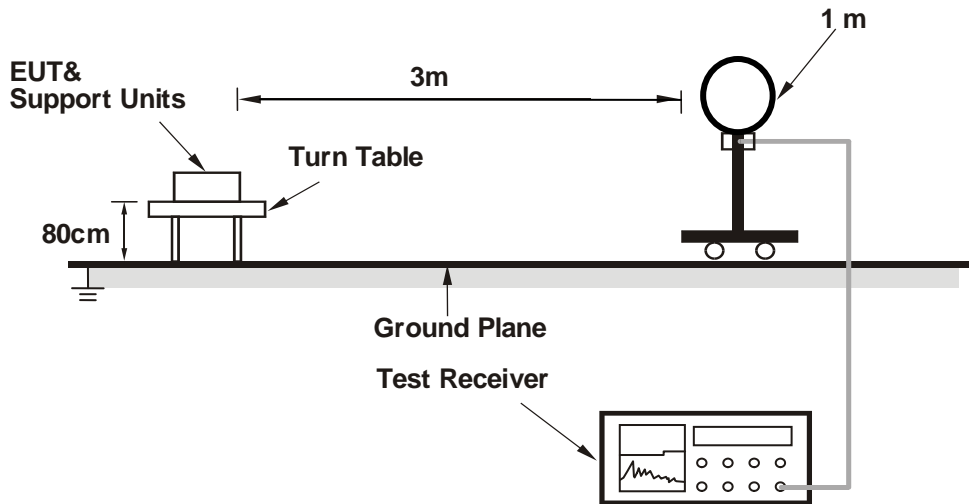

<Radiated Emission 30 MHz to 1 GHz>

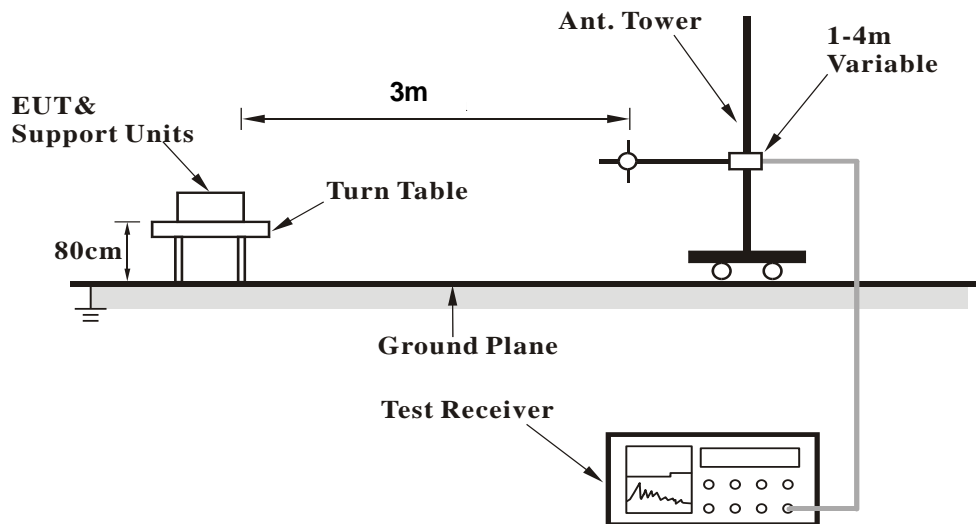

<Radiated Emission above 1 GHz>

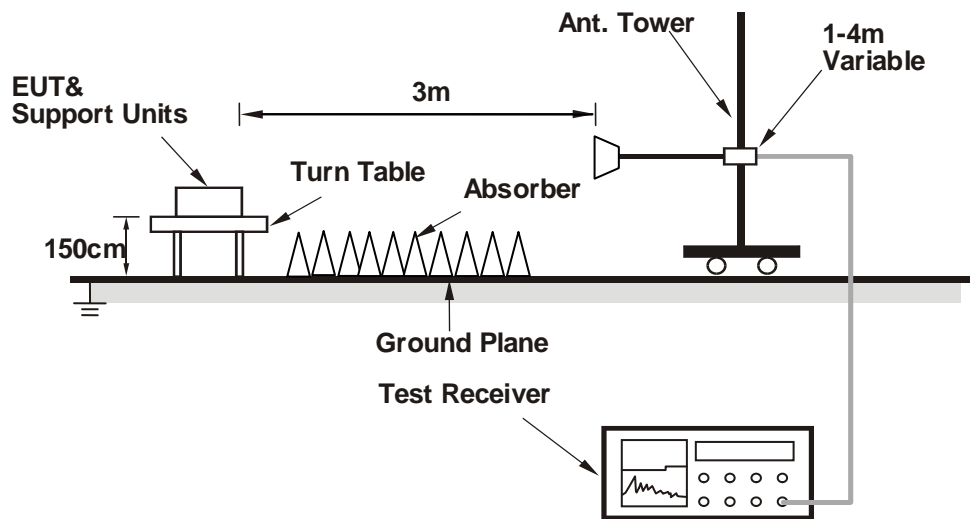

For the actual test configuration, please refer to the attached file (Test Setup Photo).

4.1.7 EUT Operating Conditions

- a. Placed the EUT on a testing table.
- b. Use the software to control the EUT under transmission condition continuously at specific channel frequency.

4.1.8 Test Results
 Above 1 GHz Data :
 802.11a

EUT Test Condition		Measurement Detail	
Channel	Channel 36	Frequency Range	1 GHz ~ 40 GHz
Input Power	120 Vac, 60 Hz	Detector Function	Peak (PK) Average (AV)
Environmental Conditions	25 deg. C, 65 % RH	Tested By	Toby Tian

Antenna Polarity & Test Distance: Horizontal at 3 m										
Frequency (MHz)	Emission Level (dBuV/m)	Read Level (dBuV)	Limit (dBuV/m)	Margin (dB)	Antenna Factor (dB/m)	Cable Loss (dB)	Preamp Factor (dB)	Antenna Height (cm)	Table Angle (Degree)	Remark
5052	40.59	40.43	54	-13.41	31.24	6.17	37.25	200	217	Average
5052	59.68	59.52	74	-14.32	31.24	6.17	37.25	200	217	Peak
5180	89.91	89.68			31.35	6.22	37.34	200	217	Average
5180	99.16	98.93			31.35	6.22	37.34	200	217	Peak
*10360	52.17	56.07	68.2	-16.03	39.19	9.05	52.14	101	174	Peak

Antenna Polarity & Test Distance: Vertical at 3 m										
Frequency (MHz)	Emission Level (dBuV/m)	Read Level (dBuV)	Limit (dBuV/m)	Margin (dB)	Antenna Factor (dB/m)	Cable Loss (dB)	Preamp Factor (dB)	Antenna Height (cm)	Table Angle (Degree)	Remark
5150	52.58	52.38	54	-1.42	31.32	6.2	37.32	228	288	Average
5150	66.14	65.94	74	-7.86	31.32	6.2	37.32	228	288	Peak
5180	103.53	103.3			31.35	6.22	37.34	228	288	Average
5180	112.04	111.81			31.35	6.22	37.34	228	288	Peak
*10360	52.94	56.84	68.2	-15.26	39.19	9.05	52.14	105	99	Peak

Remarks:

- Emission Level = Read Level + Antenna Factor + Cable Loss - Preamp Factor
 Margin value = Emission level – Limit value
- 5180 MHz: Fundamental Frequency
- *: Out of Restricted Band
- The emission levels of other frequencies were very low against the limit.

EUT Test Condition		Measurement Detail	
Channel	Channel 44	Frequency Range	1 GHz ~ 40 GHz
Input Power	120 Vac, 60 Hz	Detector Function	Peak (PK) Average (AV)
Environmental Conditions	25 deg. C, 65 % RH	Tested By	Toby Tian

Antenna Polarity & Test Distance: Horizontal at 3 m										
Frequency (MHz)	Emission Level (dBuV/m)	Read Level (dBuV)	Limit (dBuV/m)	Margin (dB)	Antenna Factor (dB/m)	Cable Loss (dB)	Preamp Factor (dB)	Antenna Height (cm)	Table Angle (Degree)	Remark
5030	38.4	38.26	54	-15.6	31.23	6.15	37.24	200	217	Average
5030	59.23	59.09	74	-14.77	31.23	6.15	37.24	200	217	Peak
5220	91.02	90.77			31.37	6.24	37.36	200	217	Average
5220	99.6	99.35			31.37	6.24	37.36	200	217	Peak
5434	38.59	37.85	54	-15.41	31.55	6.32	37.13	200	217	Average
5434	60.22	59.48	74	-13.78	31.55	6.32	37.13	200	217	Peak
*10440	52.48	56.58	68.2	-15.72	39.29	9.09	52.48	101	157	Peak

Antenna Polarity & Test Distance: Vertical at 3 m										
Frequency (MHz)	Emission Level (dBuV/m)	Read Level (dBuV)	Limit (dBuV/m)	Margin (dB)	Antenna Factor (dB/m)	Cable Loss (dB)	Preamp Factor (dB)	Antenna Height (cm)	Table Angle (Degree)	Remark
5146	42.59	42.39	54	-11.41	31.32	6.2	37.32	226	287	Average
5146	60.22	60.02	74	-13.78	31.32	6.2	37.32	226	287	Peak
5220	104.47	104.22			31.37	6.24	37.36	226	287	Average
5220	112.53	112.28			31.37	6.24	37.36	226	287	Peak
5390	41.68	41.04	54	-12.32	31.51	6.31	37.18	226	287	Average
5390	60.78	60.14	74	-13.22	31.51	6.31	37.18	226	287	Peak
*10440	52.77	56.87	68.2	-15.43	39.29	9.09	52.48	107	87	Peak

Remarks:

- Emission Level = Read Level + Antenna Factor + Cable Loss - Preamp Factor
Margin value = Emission level – Limit value
- 5220 MHz: Fundamental Frequency
- *: Out of Restricted Band
- The emission levels of other frequencies were very low against the limit.

EUT Test Condition		Measurement Detail	
Channel	Channel 48	Frequency Range	1 GHz ~ 40 GHz
Input Power	120 Vac, 60 Hz	Detector Function	Peak (PK) Average (AV)
Environmental Conditions	25 deg. C, 65 % RH	Tested By	Toby Tian

Antenna Polarity & Test Distance: Horizontal at 3 m										
Frequency (MHz)	Emission Level (dBuV/m)	Read Level (dBuV)	Limit (dBuV/m)	Margin (dB)	Antenna Factor (dB/m)	Cable Loss (dB)	Preamp Factor (dB)	Antenna Height (cm)	Table Angle (Degree)	Remark
5054	38.39	38.23	54	-15.61	31.24	6.17	37.25	200	217	Average
5054	59.85	59.69	74	-14.15	31.24	6.17	37.25	200	217	Peak
5240	91.47	91.15			31.39	6.25	37.32	200	217	Average
5240	99.88	99.56			31.39	6.25	37.32	200	217	Peak
5402	38.47	37.81	54	-15.53	31.52	6.32	37.18	200	217	Average
5402	60.23	59.57	74	-13.77	31.52	6.32	37.18	200	217	Peak
*10480	52.57	56.82	68.2	-15.63	39.37	9.09	52.71	101	180	Peak

Antenna Polarity & Test Distance: Vertical at 3 m										
Frequency (MHz)	Emission Level (dBuV/m)	Read Level (dBuV)	Limit (dBuV/m)	Margin (dB)	Antenna Factor (dB/m)	Cable Loss (dB)	Preamp Factor (dB)	Antenna Height (cm)	Table Angle (Degree)	Remark
5108	41.82	41.62	54	-12.18	31.29	6.19	37.28	225	278	Average
5108	60.31	60.11	74	-13.69	31.29	6.19	37.28	225	278	Peak
5240	104.81	104.49			31.39	6.25	37.32	225	278	Average
5240	112.73	112.41			31.39	6.25	37.32	225	278	Peak
5430	41.65	40.91	54	-12.35	31.55	6.32	37.13	225	278	Average
5430	60.56	59.82	74	-13.44	31.55	6.32	37.13	225	278	Peak
*10480	52.92	57.17	68.2	-15.28	39.37	9.09	52.71	106	101	Peak

Remarks:

- Emission Level = Read Level + Antenna Factor + Cable Loss - Preamp Factor
Margin value = Emission level – Limit value
- 5240 MHz: Fundamental Frequency
- *: Out of Restricted Band
- The emission levels of other frequencies were very low against the limit.

EUT Test Condition		Measurement Detail	
Channel	Channel 52	Frequency Range	1 GHz ~ 40 GHz
Input Power	120 Vac, 60 Hz	Detector Function	Peak (PK) Average (AV)
Environmental Conditions	25 deg. C, 65 % RH	Tested By	Jisyong Wang

Antenna Polarity & Test Distance: Horizontal at 3 m										
Frequency (MHz)	Emission Level (dBuV/m)	Read Level (dBuV)	Limit (dBuV/m)	Margin (dB)	Antenna Factor (dB/m)	Cable Loss (dB)	Preamp Factor (dB)	Antenna Height (cm)	Table Angle (Degree)	Remark
5100.26	38.5	37.96	54	-15.5	31.53	6.29	37.28	111	43	Average
5100.26	51.2	50.66	74	-22.8	31.53	6.29	37.28	111	43	Peak
5260	95.88	57.8			31.65	6.43	0	111	43	Average
5260	104.9	66.82			31.65	6.43	0	111	43	Peak
5431.84	38.89	37.77	54	-15.11	31.76	6.49	37.13	111	43	Average
5431.84	51.93	50.81	74	-22.07	31.76	6.49	37.13	111	43	Peak
*10520	56.03	58.83	68.2	-12.17	39.66	10.27	52.73	152	231	Peak

Antenna Polarity & Test Distance: Vertical at 3 m										
Frequency (MHz)	Emission Level (dBuV/m)	Read Level (dBuV)	Limit (dBuV/m)	Margin (dB)	Antenna Factor (dB/m)	Cable Loss (dB)	Preamp Factor (dB)	Antenna Height (cm)	Table Angle (Degree)	Remark
5112.32	44.87	44.31	54	-9.13	31.54	6.3	37.28	138	9	Average
5112.32	56.69	56.13	74	-17.31	31.54	6.3	37.28	138	9	Peak
5260	105.33	67.25			31.65	6.43	0	138	9	Average
5260	114.08	76			31.65	6.43	0	138	9	Peak
5377.28	43.22	42.21	54	-10.78	31.72	6.47	37.18	138	9	Average
5377.28	56.03	55.02	74	-17.97	31.72	6.47	37.18	138	9	Peak
*10520	56.05	58.85	68.2	-12.15	39.66	10.27	52.73	152	231	Peak

Remarks:

- Emission Level = Read Level + Antenna Factor + Cable Loss - Preamp Factor
Margin value = Emission level – Limit value
- 5260 MHz: Fundamental Frequency
- *: Out of Restricted Band
- The emission levels of other frequencies were very low against the limit.

EUT Test Condition		Measurement Detail	
Channel	Channel 60	Frequency Range	1 GHz ~ 40 GHz
Input Power	120 Vac, 60 Hz	Detector Function	Peak (PK) Average (AV)
Environmental Conditions	25 deg. C, 65 % RH	Tested By	Jisyong Wang

Antenna Polarity & Test Distance: Horizontal at 3 m										
Frequency (MHz)	Emission Level (dBuV/m)	Read Level (dBuV)	Limit (dBuV/m)	Margin (dB)	Antenna Factor (dB/m)	Cable Loss (dB)	Preamp Factor (dB)	Antenna Height (cm)	Table Angle (Degree)	Remark
5147.24	39.08	38.5	54	-14.92	31.56	6.34	37.32	118	44	Average
5147.24	51.94	51.36	74	-22.06	31.56	6.34	37.32	118	44	Peak
5300	95.36	94.42			31.67	6.46	37.19	118	44	Average
5300	104.34	103.4			31.67	6.46	37.19	118	44	Peak
5374.2	38.74	37.73	54	-15.26	31.72	6.47	37.18	118	44	Average
5374.2	51.91	50.9	74	-22.09	31.72	6.47	37.18	118	44	Peak
10600	45.8	48.63	54	-8.2	39.85	10.43	53.11	155	122	Average
10600	55.66	58.49	74	-18.34	39.85	10.43	53.11	155	122	Peak

Antenna Polarity & Test Distance: Vertical at 3 m										
Frequency (MHz)	Emission Level (dBuV/m)	Read Level (dBuV)	Limit (dBuV/m)	Margin (dB)	Antenna Factor (dB/m)	Cable Loss (dB)	Preamp Factor (dB)	Antenna Height (cm)	Table Angle (Degree)	Remark
5137.7	43.35	42.77	54	-10.65	31.55	6.33	37.3	104	48	Average
5137.7	54.99	54.41	74	-19.01	31.55	6.33	37.3	104	48	Peak
5300	102.53	101.59			31.67	6.46	37.19	104	48	Average
5300	111.56	110.62			31.67	6.46	37.19	104	48	Peak
5378.16	41.75	40.73	54	-12.25	31.73	6.47	37.18	104	48	Average
5378.16	54.7	53.68	74	-19.3	31.73	6.47	37.18	104	48	Peak
10600	45.47	48.3	54	-8.53	39.85	10.43	53.11	165	231	Average
10600	55.48	58.31	74	-18.52	39.85	10.43	53.11	165	231	Peak

Remarks:

- Emission Level = Read Level + Antenna Factor + Cable Loss - Preamp Factor
Margin value = Emission level – Limit value
- 5300 MHz: Fundamental Frequency
- *: Out of Restricted Band
- The emission levels of other frequencies were very low against the limit.

EUT Test Condition		Measurement Detail	
Channel	Channel 64	Frequency Range	1 GHz ~ 40 GHz
Input Power	120 Vac, 60 Hz	Detector Function	Peak (PK) Average (AV)
Environmental Conditions	25 deg. C, 65 % RH	Tested By	Jisyong Wang

Antenna Polarity & Test Distance: Horizontal at 3 m										
Frequency (MHz)	Emission Level (dBuV/m)	Read Level (dBuV)	Limit (dBuV/m)	Margin (dB)	Antenna Factor (dB/m)	Cable Loss (dB)	Preamp Factor (dB)	Antenna Height (cm)	Table Angle (Degree)	Remark
5320	96.1	95.15			31.68	6.46	37.19	105	40	Average
5320	104.95	104			31.68	6.46	37.19	105	40	Peak
5352.42	41.17	40.18	54	-12.83	31.7	6.47	37.18	105	40	Average
5352.42	56.73	55.74	74	-17.27	31.7	6.47	37.18	105	40	Peak
10640	45.34	48.12	54	-8.66	39.93	10.36	53.07	111	152	Average
10640	55.48	58.26	74	-18.52	39.93	10.36	53.07	111	152	Peak

Antenna Polarity & Test Distance: Vertical at 3 m										
Frequency (MHz)	Emission Level (dBuV/m)	Read Level (dBuV)	Limit (dBuV/m)	Margin (dB)	Antenna Factor (dB/m)	Cable Loss (dB)	Preamp Factor (dB)	Antenna Height (cm)	Table Angle (Degree)	Remark
5320	103.53	102.58			31.68	6.46	37.19	158	20	Average
5320	112.53	111.58			31.68	6.46	37.19	158	20	Peak
5350.33	47.24	46.25	54	-6.76	31.7	6.47	37.18	158	20	Average
5350.33	61.6	60.61	74	-12.4	31.7	6.47	37.18	158	20	Peak
10640	45.34	48.12	54	-8.66	39.93	10.36	53.07	111	152	Average
10640	55.48	58.26	74	-18.52	39.93	10.36	53.07	111	152	Peak

Remarks:

- Emission Level = Read Level + Antenna Factor + Cable Loss - Preamp Factor
Margin value = Emission level – Limit value
- 5320 MHz: Fundamental Frequency
- *: Out of Restricted Band
- The emission levels of other frequencies were very low against the limit.

EUT Test Condition		Measurement Detail	
Channel	Channel 100	Frequency Range	1 GHz ~ 40 GHz
Input Power	120 Vac, 60 Hz	Detector Function	Peak (PK) Average (AV)
Environmental Conditions	25 deg. C, 65 % RH	Tested By	Jisyong Wang

Antenna Polarity & Test Distance: Horizontal at 3 m										
Frequency (MHz)	Emission Level (dBuV/m)	Read Level (dBuV)	Limit (dBuV/m)	Margin (dB)	Antenna Factor (dB/m)	Cable Loss (dB)	Preamp Factor (dB)	Antenna Height (cm)	Table Angle (Degree)	Remark
5459.6	40.53	39.33	54	-13.47	31.77	6.51	37.08	135	37	Average
5459.6	52.75	51.55	74	-21.25	31.77	6.51	37.08	135	37	Peak
*5470	58.37	57.14	68.2	-9.83	31.79	6.52	37.08	135	37	Peak
5500	95.58	94.26			31.81	6.54	37.03	135	37	Average
5500	104.5	103.18			31.81	6.54	37.03	135	37	Peak
*5725	51.52	50.01	68.2	-16.68	32.18	6.76	37.43	135	37	Peak
11000	46.35	48.25	54	-7.65	40.73	10.4	53.03	152	231	Average
11000	56.28	58.18	74	-17.72	40.73	10.4	53.03	152	231	Peak

Antenna Polarity & Test Distance: Vertical at 3 m										
Frequency (MHz)	Emission Level (dBuV/m)	Read Level (dBuV)	Limit (dBuV/m)	Margin (dB)	Antenna Factor (dB/m)	Cable Loss (dB)	Preamp Factor (dB)	Antenna Height (cm)	Table Angle (Degree)	Remark
5459.6	45.89	44.69	54	-8.11	31.77	6.51	37.08	101	300	Average
5459.6	59.24	58.04	74	-14.76	31.77	6.51	37.08	101	300	Peak
*5470	65.6	64.37	68.2	-2.6	31.79	6.52	37.08	101	300	Peak
5500	103.05	101.73			31.81	6.54	37.03	101	300	Average
5500	112.15	110.83			31.81	6.54	37.03	101	300	Peak
*5725	52.5	50.99	68.2	-15.7	32.18	6.76	37.43	101	300	Peak
11000	46.72	48.62	54	-7.28	40.73	10.4	53.03	251	231	Average
11000	56.72	58.62	74	-17.28	40.73	10.4	53.03	251	231	Peak

Remarks:

- Emission Level = Read Level + Antenna Factor + Cable Loss - Preamp Factor
Margin value = Emission level – Limit value
- 5500 MHz: Fundamental Frequency
- *: Out of Restricted Band
- The emission levels of other frequencies were very low against the limit.

EUT Test Condition		Measurement Detail	
Channel	Channel 116	Frequency Range	1 GHz ~ 40 GHz
Input Power	120 Vac, 60 Hz	Detector Function	Peak (PK) Average (AV)
Environmental Conditions	25 deg. C, 65 % RH	Tested By	Jisyong Wang

Antenna Polarity & Test Distance: Horizontal at 3 m										
Frequency (MHz)	Emission Level (dBuV/m)	Read Level (dBuV)	Limit (dBuV/m)	Margin (dB)	Antenna Factor (dB/m)	Cable Loss (dB)	Preamp Factor (dB)	Antenna Height (cm)	Table Angle (Degree)	Remark
5356.88	39.34	38.35	54	-14.66	31.7	6.47	37.18	113	46	Average
5356.88	52.6	51.61	74	-21.4	31.7	6.47	37.18	113	46	Peak
*5470	51.01	49.78	68.2	-17.19	31.79	6.52	37.08	113	46	Peak
5580	96.23	94.82			31.92	6.65	37.16	113	46	Average
5580	105.25	103.84			31.92	6.65	37.16	113	46	Peak
*5725	51.38	49.87	68.2	-16.82	32.18	6.76	37.43	113	46	Peak
11160	47.33	49.03	54	-6.67	40.56	10.52	52.78	251	213	Average
11160	57.37	59.07	74	-16.63	40.56	10.52	52.78	251	213	Peak
Antenna Polarity & Test Distance: Vertical at 3 m										
Frequency (MHz)	Emission Level (dBuV/m)	Read Level (dBuV)	Limit (dBuV/m)	Margin (dB)	Antenna Factor (dB/m)	Cable Loss (dB)	Preamp Factor (dB)	Antenna Height (cm)	Table Angle (Degree)	Remark
5435.6	45.43	44.31	54	-8.57	31.76	6.49	37.13	107	302	Average
5435.6	58.17	57.05	74	-15.83	31.76	6.49	37.13	107	302	Peak
*5470	56.04	54.81	68.2	-12.16	31.79	6.52	37.08	107	302	Peak
5580	102.83	101.42			31.92	6.65	37.16	107	302	Average
5580	112.02	110.61			31.92	6.65	37.16	107	302	Peak
*5725	52.59	51.08	68.2	-15.61	32.18	6.76	37.43	107	302	Peak
11160	48.06	49.76	54	-5.94	40.56	10.52	52.78	251	231	Average
11160	58.04	59.74	74	-15.96	40.56	10.52	52.78	251	231	Peak

Remarks:

- Emission Level = Read Level + Antenna Factor + Cable Loss - Preamp Factor
Margin value = Emission level – Limit value
- 5580 MHz: Fundamental Frequency
- *: Out of Restricted Band
- The emission levels of other frequencies were very low against the limit.

EUT Test Condition		Measurement Detail	
Channel	Channel 140	Frequency Range	1 GHz ~ 40 GHz
Input Power	120 Vac, 60 Hz	Detector Function	Peak (PK) Average (AV)
Environmental Conditions	25 deg. C, 65 % RH	Tested By	Jisyong Wang

Antenna Polarity & Test Distance: Horizontal at 3 m										
Frequency (MHz)	Emission Level (dBuV/m)	Read Level (dBuV)	Limit (dBuV/m)	Margin (dB)	Antenna Factor (dB/m)	Cable Loss (dB)	Preamp Factor (dB)	Antenna Height (cm)	Table Angle (Degree)	Remark
5424.56	39.32	38.21	54	-14.68	31.75	6.49	37.13	114	35	Average
5424.56	52.54	51.43	74	-21.46	31.75	6.49	37.13	114	35	Peak
*5470	51.15	49.92	68.2	-17.05	31.79	6.52	37.08	114	35	Peak
5700	97.44	95.99			32.12	6.73	37.4	114	35	Average
5700	106.36	104.91			32.12	6.73	37.4	114	35	Peak
*5725	64.68	63.17	68.2	-3.52	32.18	6.76	37.43	114	35	Peak
11400	47.31	49.21	54	-6.69	40.33	10.47	52.7	202	231	Average
11400	57.45	59.35	74	-16.55	40.33	10.47	52.7	202	231	Peak

Antenna Polarity & Test Distance: Vertical at 3 m										
Frequency (MHz)	Emission Level (dBuV/m)	Read Level (dBuV)	Limit (dBuV/m)	Margin (dB)	Antenna Factor (dB/m)	Cable Loss (dB)	Preamp Factor (dB)	Antenna Height (cm)	Table Angle (Degree)	Remark
5356.72	43.81	42.82	54	-10.19	31.7	6.47	37.18	106	297	Average
5356.72	56.66	55.67	74	-17.34	31.7	6.47	37.18	106	297	Peak
*5470	54.58	53.35	68.2	-13.62	31.79	6.52	37.08	106	297	Peak
5700	101.08	99.63			32.12	6.73	37.4	106	297	Average
5700	110.03	108.58			32.12	6.73	37.4	106	297	Peak
*5725	67.51	66	68.2	-0.69	32.18	6.76	37.43	106	297	Peak
11400	47.85	49.75	54	-6.15	40.33	10.47	52.7	256	321	Average
11400	57.83	59.73	74	-16.17	40.33	10.47	52.7	256	321	Peak

Remarks:

- Emission Level = Read Level + Antenna Factor + Cable Loss - Preamp Factor
Margin value = Emission level – Limit value
- 5700 MHz: Fundamental Frequency
- *: Out of Restricted Band
- The emission levels of other frequencies were very low against the limit.

EUT Test Condition		Measurement Detail	
Channel	Channel 149	Frequency Range	1 GHz ~ 40 GHz
Input Power	120 Vac, 60 Hz	Detector Function	Peak (PK) Average (AV)
Environmental Conditions	25 deg. C, 65 % RH	Tested By	Toby Tian

<Spurious Emission>

Antenna Polarity & Test Distance: Horizontal at 3 m										
Frequency (MHz)	Emission Level (dBuV/m)	Read Level (dBuV)	Limit (dBuV/m)	Margin (dB)	Antenna Factor (dB/m)	Cable Loss (dB)	Preamp Factor (dB)	Antenna Height (cm)	Table Angle (Degree)	Remark
5745	89.87	88.6			31.99	6.75	37.47	128	225	Average
5745	99.17	97.9			31.99	6.75	37.47	128	225	Peak
11490	45.91	48.8	54	-8.09	39.91	10.03	52.83	110	122	Average
11490	56.62	59.51	74	-17.38	39.91	10.03	52.83	110	122	Peak
Antenna Polarity & Test Distance: Vertical at 3 m										
Frequency (MHz)	Emission Level (dBuV/m)	Read Level (dBuV)	Limit (dBuV/m)	Margin (dB)	Antenna Factor (dB/m)	Cable Loss (dB)	Preamp Factor (dB)	Antenna Height (cm)	Table Angle (Degree)	Remark
5745	103.95	102.68			31.99	6.75	37.47	209	292	Average
5745	112.34	111.07			31.99	6.75	37.47	209	292	Peak
11490	45.03	47.92	54	-8.97	39.91	10.03	52.83	100	196	Average
11490	56.61	59.5	74	-17.39	39.91	10.03	52.83	100	196	Peak

<Out of Band Emission (OOBE)>

Antenna Polarity & Test Distance: Horizontal at 3 m										
Frequency (MHz)	Emission Level (dBuV/m)	Read Level (dBuV)	Limit (dBuV/m)	Margin (dB)	Antenna Factor (dB/m)	Cable Loss (dB)	Preamp Factor (dB)	Antenna Height (cm)	Table Angle (Degree)	Remark
5647.375	47.91	46.75	68.2	-20.29	31.82	6.62	37.28	128	225	Peak
5654.025	47.19	46.06	71.19	-24	31.85	6.62	37.34	128	225	Peak
5921.925	47.29	45.49	70.47	-23.18	32.29	7.01	37.5	128	225	Peak
5929.05	47.62	45.82	68.2	-20.58	32.29	7.01	37.5	128	225	Peak
Antenna Polarity & Test Distance: Vertical at 3 m										
Frequency (MHz)	Emission Level (dBuV/m)	Read Level (dBuV)	Limit (dBuV/m)	Margin (dB)	Antenna Factor (dB/m)	Cable Loss (dB)	Preamp Factor (dB)	Antenna Height (cm)	Table Angle (Degree)	Remark
5645	50.13	48.97	68.2	-18.07	31.82	6.62	37.28	209	292	Peak
5655.45	49.39	48.26	72.25	-22.86	31.85	6.62	37.34	209	292	Peak
5921.925	49.09	47.29	70.47	-21.38	32.29	7.01	37.5	209	292	Peak
5929.05	49.02	47.22	68.2	-19.18	32.29	7.01	37.5	209	292	Peak

Remarks:

- Emission Level = Read Level + Antenna Factor + Cable Loss - Preamp Factor
Margin value = Emission level – Limit value
- 5745 MHz: Fundamental Frequency
- *: Out of Restricted Band
- The emission levels of other frequencies were very low against the limit.

EUT Test Condition		Measurement Detail	
Channel	Channel 157	Frequency Range	1 GHz ~ 40 GHz
Input Power	120 Vac, 60 Hz	Detector Function	Peak (PK) Average (AV)
Environmental Conditions	25 deg. C, 65 % RH	Tested By	Toby Tian

<Spurious Emission>

Antenna Polarity & Test Distance: Horizontal at 3 m										
Frequency (MHz)	Emission Level (dBuV/m)	Read Level (dBuV)	Limit (dBuV/m)	Margin (dB)	Antenna Factor (dB/m)	Cable Loss (dB)	Preamp Factor (dB)	Antenna Height (cm)	Table Angle (Degree)	Remark
5785	90.72	89.4			32.04	6.82	37.54	130	225	Average
5785	99.85	98.53			32.04	6.82	37.54	130	225	Peak
11570	44.27	47.73	54	-9.73	39.78	10.09	53.33	105	116	Average
11570	55.47	58.93	74	-18.53	39.78	10.09	53.33	105	116	Peak

Antenna Polarity & Test Distance: Vertical at 3 m										
Frequency (MHz)	Emission Level (dBuV/m)	Read Level (dBuV)	Limit (dBuV/m)	Margin (dB)	Antenna Factor (dB/m)	Cable Loss (dB)	Preamp Factor (dB)	Antenna Height (cm)	Table Angle (Degree)	Remark
5785	103.41	102.09			32.04	6.82	37.54	210	292	Average
5785	112.84	111.52			32.04	6.82	37.54	210	292	Peak
11570	43.35	46.81	54	-10.65	39.78	10.09	53.33	100	117	Average
11570	54.84	58.3	74	-19.16	39.78	10.09	53.33	100	117	Peak

<Out of Band Emission (OOBE)>

Antenna Polarity & Test Distance: Horizontal at 3 m										
Frequency (MHz)	Emission Level (dBuV/m)	Read Level (dBuV)	Limit (dBuV/m)	Margin (dB)	Antenna Factor (dB/m)	Cable Loss (dB)	Preamp Factor (dB)	Antenna Height (cm)	Table Angle (Degree)	Remark
5631.7	48.27	47.2	68.2	-19.93	31.79	6.56	37.28	130	225	Peak
5654.5	47.23	46.1	71.54	-24.31	31.85	6.62	37.34	130	225	Peak
5920.975	47.53	45.76	71.17	-23.64	32.26	7.01	37.5	130	225	Peak
5929.525	47.75	45.95	68.2	-20.45	32.29	7.01	37.5	130	225	Peak

Antenna Polarity & Test Distance: Vertical at 3 m										
Frequency (MHz)	Emission Level (dBuV/m)	Read Level (dBuV)	Limit (dBuV/m)	Margin (dB)	Antenna Factor (dB/m)	Cable Loss (dB)	Preamp Factor (dB)	Antenna Height (cm)	Table Angle (Degree)	Remark
5622.675	54.98	53.85	68.2	-13.22	31.79	6.56	37.22	210	292	Peak
5655.45	48.51	47.38	72.25	-23.74	31.85	6.62	37.34	210	292	Peak
5922.875	48.74	46.94	69.77	-21.03	32.29	7.01	37.5	210	292	Peak
5927.15	49.34	47.54	68.2	-18.86	32.29	7.01	37.5	210	292	Peak

Remarks:

- Emission Level = Read Level + Antenna Factor + Cable Loss - Preamp Factor
Margin value = Emission level – Limit value
- 5785 MHz: Fundamental Frequency
- *: Out of Restricted Band
- The emission levels of other frequencies were very low against the limit.

EUT Test Condition		Measurement Detail	
Channel	Channel 165	Frequency Range	1 GHz ~ 40 GHz
Input Power	120 Vac, 60 Hz	Detector Function	Peak (PK) Average (AV)
Environmental Conditions	25 deg. C, 65 % RH	Tested By	Toby Tian

<Spurious Emission>

Antenna Polarity & Test Distance: Horizontal at 3 m										
Frequency (MHz)	Emission Level (dBuV/m)	Read Level (dBuV)	Limit (dBuV/m)	Margin (dB)	Antenna Factor (dB/m)	Cable Loss (dB)	Preamp Factor (dB)	Antenna Height (cm)	Table Angle (Degree)	Remark
5825	89.92	88.45			32.12	6.88	37.53	135	225	Average
5825	99.79	98.32			32.12	6.88	37.53	135	225	Peak
11650	44.3	47.85	54	-9.7	39.65	10.15	53.35	100	155	Average
11650	55.87	59.42	74	-18.13	39.65	10.15	53.35	100	155	Peak
Antenna Polarity & Test Distance: Vertical at 3 m										
Frequency (MHz)	Emission Level (dBuV/m)	Read Level (dBuV)	Limit (dBuV/m)	Margin (dB)	Antenna Factor (dB/m)	Cable Loss (dB)	Preamp Factor (dB)	Antenna Height (cm)	Table Angle (Degree)	Remark
5825	103.59	102.12			32.12	6.88	37.53	207	290	Average
5825	112.58	111.11			32.12	6.88	37.53	207	290	Peak
11650	43.69	47.24	54	-10.31	39.65	10.15	53.35	100	162	Average
11650	55.68	59.23	74	-18.32	39.65	10.15	53.35	100	162	Peak

<Out of Band Emission (OOBE)>

Antenna Polarity & Test Distance: Horizontal at 3 m										
Frequency (MHz)	Emission Level (dBuV/m)	Read Level (dBuV)	Limit (dBuV/m)	Margin (dB)	Antenna Factor (dB/m)	Cable Loss (dB)	Preamp Factor (dB)	Antenna Height (cm)	Table Angle (Degree)	Remark
5646.425	48.92	47.76	68.2	-19.28	31.82	6.62	37.28	135	225	Peak
5653.075	47.22	46.03	70.49	-23.27	31.85	6.62	37.28	135	225	Peak
5921.45	48.5	46.73	70.82	-22.32	32.26	7.01	37.5	135	225	Peak
5933.325	48.53	46.73	68.2	-19.67	32.29	7.01	37.5	135	225	Peak
Antenna Polarity & Test Distance: Vertical at 3 m										
Frequency (MHz)	Emission Level (dBuV/m)	Read Level (dBuV)	Limit (dBuV/m)	Margin (dB)	Antenna Factor (dB/m)	Cable Loss (dB)	Preamp Factor (dB)	Antenna Height (cm)	Table Angle (Degree)	Remark
5646.9	52.01	50.85	68.2	-16.19	31.82	6.62	37.28	207	290	Peak
5653.55	51.95	50.76	70.84	-18.89	31.85	6.62	37.28	207	290	Peak
5918.125	52.1	50.33	73.27	-21.17	32.26	7.01	37.5	207	290	Peak
5930	51.8	50	68.2	-16.4	32.29	7.01	37.5	207	290	Peak

Remarks:

- Emission Level = Read Level + Antenna Factor + Cable Loss - Preamp Factor
Margin value = Emission level – Limit value
- 5825 MHz: Fundamental Frequency
- *: Out of Restricted Band
- The emission levels of other frequencies were very low against the limit.

802.11n (HT20)

EUT Test Condition		Measurement Detail	
Channel	Channel 36	Frequency Range	1 GHz ~ 40 GHz
Input Power	120 Vac, 60 Hz	Detector Function	Peak (PK) Average (AV)
Environmental Conditions	25 deg. C, 65 % RH	Tested By	Toby Tian

Antenna Polarity & Test Distance: Horizontal at 3 m

Frequency (MHz)	Emission Level (dBuV/m)	Read Level (dBuV)	Limit (dBuV/m)	Margin (dB)	Antenna Factor (dB/m)	Cable Loss (dB)	Preamp Factor (dB)	Antenna Height (cm)	Table Angle (Degree)	Remark
5126	39.27	39.06	54	-14.73	31.31	6.2	37.3	178	25	Average
5126	59.3	59.09	74	-14.7	31.31	6.2	37.3	178	25	Peak
5180	89.41	89.18			31.35	6.22	37.34	178	25	Average
5180	98.49	98.26			31.35	6.22	37.34	178	25	Peak
5404	38.9	38.24	54	-15.1	31.52	6.32	37.18	178	25	Average
5404	59.73	59.07	74	-14.27	31.52	6.32	37.18	178	25	Peak
*10360	54.71	58.61	68.2	-13.49	39.19	9.05	52.14	100	198	Peak

Antenna Polarity & Test Distance: Vertical at 3 m

Frequency (MHz)	Emission Level (dBuV/m)	Read Level (dBuV)	Limit (dBuV/m)	Margin (dB)	Antenna Factor (dB/m)	Cable Loss (dB)	Preamp Factor (dB)	Antenna Height (cm)	Table Angle (Degree)	Remark
5150	51.21	51.01	54	-2.79	31.32	6.2	37.32	225	280	Average
5150	64.58	64.38	74	-9.42	31.32	6.2	37.32	225	280	Peak
5180	98.16	97.93			31.35	6.22	37.34	225	280	Average
5180	111.85	111.62			31.35	6.22	37.34	225	280	Peak
5386	41.69	41.05	54	-12.31	31.51	6.31	37.18	225	280	Average
5386	60.39	59.75	74	-13.61	31.51	6.31	37.18	225	280	Peak
*10360	55.87	59.77	68.2	-12.33	39.19	9.05	52.14	100	57	Peak

Remarks:

- Emission Level = Read Level + Antenna Factor + Cable Loss - Preamp Factor
Margin value = Emission level – Limit value
- 5180 MHz: Fundamental Frequency
- *: Out of Restricted Band
- The emission levels of other frequencies were very low against the limit.

EUT Test Condition		Measurement Detail	
Channel	Channel 44	Frequency Range	1 GHz ~ 40 GHz
Input Power	120 Vac, 60 Hz	Detector Function	Peak (PK) Average (AV)
Environmental Conditions	25 deg. C, 65 % RH	Tested By	Toby Tian

Antenna Polarity & Test Distance: Horizontal at 3 m										
Frequency (MHz)	Emission Level (dBuV/m)	Read Level (dBuV)	Limit (dBuV/m)	Margin (dB)	Antenna Factor (dB/m)	Cable Loss (dB)	Preamp Factor (dB)	Antenna Height (cm)	Table Angle (Degree)	Remark
5028	38.39	38.25	54	-15.61	31.23	6.15	37.24	166	24	Average
5028	59.96	59.82	74	-14.04	31.23	6.15	37.24	166	24	Peak
5220	91	90.75			31.37	6.24	37.36	166	24	Average
5220	99.94	99.69			31.37	6.24	37.36	166	24	Peak
5442	38.84	38.08	54	-15.16	31.55	6.34	37.13	166	24	Average
5442	60.13	59.37	74	-13.87	31.55	6.34	37.13	166	24	Peak
*10440	55.14	59.24	68.2	-13.06	39.29	9.09	52.48	100	177	Peak

Antenna Polarity & Test Distance: Vertical at 3 m										
Frequency (MHz)	Emission Level (dBuV/m)	Read Level (dBuV)	Limit (dBuV/m)	Margin (dB)	Antenna Factor (dB/m)	Cable Loss (dB)	Preamp Factor (dB)	Antenna Height (cm)	Table Angle (Degree)	Remark
5066	43.63	43.46	54	-10.37	31.25	6.17	37.25	221	281	Average
5066	61.74	61.57	74	-12.26	31.25	6.17	37.25	221	281	Peak
5220	105.02	104.77			31.37	6.24	37.36	221	281	Average
5220	113.19	112.94			31.37	6.24	37.36	221	281	Peak
5458	43.41	42.59	54	-10.59	31.56	6.34	37.08	221	281	Average
5458	60.59	59.77	74	-13.41	31.56	6.34	37.08	221	281	Peak
*10440	55.52	59.62	68.2	-12.68	39.29	9.09	52.48	100	87	Peak

Remarks:

- Emission Level = Read Level + Antenna Factor + Cable Loss - Preamp Factor
Margin value = Emission level – Limit value
- 5220 MHz: Fundamental Frequency
- *: Out of Restricted Band
- The emission levels of other frequencies were very low against the limit.

EUT Test Condition		Measurement Detail	
Channel	Channel 48	Frequency Range	1 GHz ~ 40 GHz
Input Power	120 Vac, 60 Hz	Detector Function	Peak (PK) Average (AV)
Environmental Conditions	25 deg. C, 65 % RH	Tested By	Toby Tian

Antenna Polarity & Test Distance: Horizontal at 3 m										
Frequency (MHz)	Emission Level (dBuV/m)	Read Level (dBuV)	Limit (dBuV/m)	Margin (dB)	Antenna Factor (dB/m)	Cable Loss (dB)	Preamp Factor (dB)	Antenna Height (cm)	Table Angle (Degree)	Remark
5098	38.53	38.34	54	-15.47	31.28	6.19	37.28	148	26	Average
5098	59.25	59.06	74	-14.75	31.28	6.19	37.28	148	26	Peak
5240	90.52	90.2			31.39	6.25	37.32	148	26	Average
5240	98.98	98.66			31.39	6.25	37.32	148	26	Peak
5460	38.77	37.95	54	-15.23	31.56	6.34	37.08	148	26	Average
5460	60.28	59.46	74	-13.72	31.56	6.34	37.08	148	26	Peak
*10480	54.19	58.44	68.2	-14.01	39.37	9.09	52.71	100	208	Peak

Antenna Polarity & Test Distance: Vertical at 3 m										
Frequency (MHz)	Emission Level (dBuV/m)	Read Level (dBuV)	Limit (dBuV/m)	Margin (dB)	Antenna Factor (dB/m)	Cable Loss (dB)	Preamp Factor (dB)	Antenna Height (cm)	Table Angle (Degree)	Remark
5146	43.67	43.47	54	-10.33	31.32	6.2	37.32	223	280	Average
5146	60.21	60.01	74	-13.79	31.32	6.2	37.32	223	280	Peak
5240	105.27	104.95			31.39	6.25	37.32	223	280	Average
5240	112.45	112.13			31.39	6.25	37.32	223	280	Peak
5440	43.53	42.77	54	-10.47	31.55	6.34	37.13	223	280	Average
5440	60.4	59.64	74	-13.6	31.55	6.34	37.13	223	280	Peak
*10480	55.82	60.07	68.2	-12.38	39.37	9.09	52.71	100	210	Peak

Remarks:

- Emission Level = Read Level + Antenna Factor + Cable Loss - Preamp Factor
Margin value = Emission level – Limit value
- 5240 MHz: Fundamental Frequency
- *: Out of Restricted Band
- The emission levels of other frequencies were very low against the limit.

EUT Test Condition		Measurement Detail	
Channel	Channel 52	Frequency Range	1 GHz ~ 40 GHz
Input Power	120 Vac, 60 Hz	Detector Function	Peak (PK) Average (AV)
Environmental Conditions	25 deg. C, 65 % RH	Tested By	Jisyong Wang

Antenna Polarity & Test Distance: Horizontal at 3 m										
Frequency (MHz)	Emission Level (dBuV/m)	Read Level (dBuV)	Limit (dBuV/m)	Margin (dB)	Antenna Factor (dB/m)	Cable Loss (dB)	Preamp Factor (dB)	Antenna Height (cm)	Table Angle (Degree)	Remark
5140.94	38.68	38.09	54	-15.32	31.56	6.33	37.3	149	194	Average
5140.94	51.89	51.3	74	-22.11	31.56	6.33	37.3	149	194	Peak
5260	98.33	97.52			31.65	6.43	37.27	149	194	Average
5260	107.45	106.64			31.65	6.43	37.27	149	194	Peak
5390.59	39.75	38.73	54	-14.25	31.73	6.47	37.18	149	194	Average
5390.59	52.32	51.3	74	-21.68	31.73	6.47	37.18	149	194	Peak
*10520	55.85	58.65	68.2	-12.35	39.66	10.27	52.73	152	231	Peak
Antenna Polarity & Test Distance: Vertical at 3 m										
Frequency (MHz)	Emission Level (dBuV/m)	Read Level (dBuV)	Limit (dBuV/m)	Margin (dB)	Antenna Factor (dB/m)	Cable Loss (dB)	Preamp Factor (dB)	Antenna Height (cm)	Table Angle (Degree)	Remark
5128.16	44.11	43.54	54	-9.89	31.55	6.32	37.3	173	198	Average
5128.16	56.77	56.2	74	-17.23	31.55	6.32	37.3	173	198	Peak
5260	104.28	103.47			31.65	6.43	37.27	173	198	Average
5260	113.37	112.56			31.65	6.43	37.27	173	198	Peak
5367.38	43.97	42.96	54	-10.03	31.72	6.47	37.18	173	198	Average
5367.38	57.06	56.05	74	-16.94	31.72	6.47	37.18	173	198	Peak
*10520	55.97	58.77	68.2	-12.23	39.66	10.27	52.73	165	231	Peak

Remarks:

- Emission Level = Read Level + Antenna Factor + Cable Loss - Preamp Factor
Margin value = Emission level – Limit value
- 5260 MHz: Fundamental Frequency
- *: Out of Restricted Band
- The emission levels of other frequencies were very low against the limit.

EUT Test Condition		Measurement Detail	
Channel	Channel 60	Frequency Range	1 GHz ~ 40 GHz
Input Power	120 Vac, 60 Hz	Detector Function	Peak (PK) Average (AV)
Environmental Conditions	25 deg. C, 65 % RH	Tested By	Jisyong Wang

Antenna Polarity & Test Distance: Horizontal at 3 m										
Frequency (MHz)	Emission Level (dBuV/m)	Read Level (dBuV)	Limit (dBuV/m)	Margin (dB)	Antenna Factor (dB/m)	Cable Loss (dB)	Preamp Factor (dB)	Antenna Height (cm)	Table Angle (Degree)	Remark
5052.56	38.95	38.46	54	-15.05	31.49	6.25	37.25	150	194	Average
5052.56	51.25	50.76	74	-22.75	31.49	6.25	37.25	150	194	Peak
5300	98.38	97.44			31.67	6.46	37.19	150	194	Average
5300	108.09	107.15			31.67	6.46	37.19	150	194	Peak
5401.81	39.77	38.74	54	-14.23	31.74	6.47	37.18	150	194	Average
5401.81	52.45	51.42	74	-21.55	31.74	6.47	37.18	150	194	Peak
10600	45.37	48.2	54	-8.63	39.85	10.43	53.11	152	231	Average
10600	55.31	58.14	74	-18.69	39.85	10.43	53.11	152	231	Peak

Antenna Polarity & Test Distance: Vertical at 3 m										
Frequency (MHz)	Emission Level (dBuV/m)	Read Level (dBuV)	Limit (dBuV/m)	Margin (dB)	Antenna Factor (dB/m)	Cable Loss (dB)	Preamp Factor (dB)	Antenna Height (cm)	Table Angle (Degree)	Remark
5142.56	44.39	43.8	54	-9.61	31.56	6.33	37.3	172	184	Average
5142.56	57.12	56.53	74	-16.88	31.56	6.33	37.3	172	184	Peak
5300	107.65	106.71			31.67	6.46	37.19	172	184	Average
5300	113.37	112.43			31.67	6.46	37.19	172	184	Peak
5351.87	44.42	43.43	54	-9.58	31.7	6.47	37.18	172	184	Average
5351.87	56.78	55.79	74	-17.22	31.7	6.47	37.18	172	184	Peak
10600	46.06	48.89	54	-7.94	39.85	10.43	53.11	185	231	Average
10600	56.07	58.9	74	-17.93	39.85	10.43	53.11	185	231	Peak

Remarks:

- Emission Level = Read Level + Antenna Factor + Cable Loss - Preamp Factor
Margin value = Emission level – Limit value
- 5300 MHz: Fundamental Frequency
- *: Out of Restricted Band
- The emission levels of other frequencies were very low against the limit.

EUT Test Condition		Measurement Detail	
Channel	Channel 64	Frequency Range	1 GHz ~ 40 GHz
Input Power	120 Vac, 60 Hz	Detector Function	Peak (PK) Average (AV)
Environmental Conditions	25 deg. C, 65 % RH	Tested By	Jisyong Wang

Antenna Polarity & Test Distance: Horizontal at 3 m										
Frequency (MHz)	Emission Level (dBuV/m)	Read Level (dBuV)	Limit (dBuV/m)	Margin (dB)	Antenna Factor (dB/m)	Cable Loss (dB)	Preamp Factor (dB)	Antenna Height (cm)	Table Angle (Degree)	Remark
5320	98.49	97.54			31.68	6.46	37.19	155	202	Average
5320	107.27	106.32			31.68	6.46	37.19	155	202	Peak
5351.32	41.32	40.33	54	-12.68	31.7	6.47	37.18	155	202	Average
5351.32	53	52.01	74	-21	31.7	6.47	37.18	155	202	Peak
10640	46.67	49.45	54	-7.33	39.93	10.36	53.07	152	231	Average
10640	56.67	59.45	74	-17.33	39.93	10.36	53.07	152	231	Peak
Antenna Polarity & Test Distance: Vertical at 3 m										
Frequency (MHz)	Emission Level (dBuV/m)	Read Level (dBuV)	Limit (dBuV/m)	Margin (dB)	Antenna Factor (dB/m)	Cable Loss (dB)	Preamp Factor (dB)	Antenna Height (cm)	Table Angle (Degree)	Remark
5320	106.39	105.44			31.68	6.46	37.19	165	179	Average
5320	115.18	114.23			31.68	6.46	37.19	165	179	Peak
5350	49.12	48.13	54	-4.88	31.7	6.47	37.18	158	176	Average
5350	66.72	65.73	74	-7.28	31.7	6.47	37.18	158	176	Peak
10640	45.85	48.63	54	-8.15	39.93	10.36	53.07	256	231	Average
10640	55.82	58.6	74	-18.18	39.93	10.36	53.07	256	231	Peak

Remarks:

- Emission Level = Read Level + Antenna Factor + Cable Loss - Preamp Factor
Margin value = Emission level – Limit value
- 5320 MHz: Fundamental Frequency
- *: Out of Restricted Band
- The emission levels of other frequencies were very low against the limit.

EUT Test Condition		Measurement Detail	
Channel	Channel 100	Frequency Range	1 GHz ~ 40 GHz
Input Power	120 Vac, 60 Hz	Detector Function	Peak (PK) Average (AV)
Environmental Conditions	25 deg. C, 65 % RH	Tested By	Jisyong Wang

Antenna Polarity & Test Distance: Horizontal at 3 m										
Frequency (MHz)	Emission Level (dBuV/m)	Read Level (dBuV)	Limit (dBuV/m)	Margin (dB)	Antenna Factor (dB/m)	Cable Loss (dB)	Preamp Factor (dB)	Antenna Height (cm)	Table Angle (Degree)	Remark
5418	40.28	39.23	54	-13.72	31.75	6.48	37.18	115	196	Average
5418	52.97	51.92	74	-21.03	31.75	6.48	37.18	115	196	Peak
*5470	55.35	54.12	68.2	-12.85	31.79	6.52	37.08	115	196	Peak
5500	95.2	93.88			31.81	6.54	37.03	115	196	Average
5500	104.02	102.7			31.81	6.54	37.03	115	196	Peak
*5725	51.09	49.58	68.2	-17.11	32.18	6.76	37.43	115	196	Peak
11000	46.55	48.45	54	-7.45	40.73	10.4	53.03	251	123	Average
11000	56.56	58.46	74	-17.44	40.73	10.4	53.03	251	123	Peak

Antenna Polarity & Test Distance: Vertical at 3 m										
Frequency (MHz)	Emission Level (dBuV/m)	Read Level (dBuV)	Limit (dBuV/m)	Margin (dB)	Antenna Factor (dB/m)	Cable Loss (dB)	Preamp Factor (dB)	Antenna Height (cm)	Table Angle (Degree)	Remark
5457.2	47.97	46.77	54	-6.03	31.77	6.51	37.08	164	176	Average
5457.2	59.7	58.5	74	-14.3	31.77	6.51	37.08	164	176	Peak
*5470	67.52	66.29	68.2	-0.68	31.79	6.52	37.08	164	176	Peak
5500	105.33	104.01			31.81	6.54	37.03	167	176	Average
5500	114.15	112.83			31.81	6.54	37.03	167	176	Peak
*5725	52.82	51.31	68.2	-15.38	32.18	6.76	37.43	164	176	Peak
11000	46.62	48.52	54	-7.38	40.73	10.4	53.03	155	123	Average
11000	56.65	58.55	74	-17.35	40.73	10.4	53.03	155	123	Peak

Remarks:

- Emission Level = Read Level + Antenna Factor + Cable Loss - Preamp Factor
Margin value = Emission level – Limit value
- 5500 MHz: Fundamental Frequency
- *: Out of Restricted Band
- The emission levels of other frequencies were very low against the limit.

EUT Test Condition		Measurement Detail	
Channel	Channel 116	Frequency Range	1 GHz ~ 40 GHz
Input Power	120 Vac, 60 Hz	Detector Function	Peak (PK) Average (AV)
Environmental Conditions	25 deg. C, 65 % RH	Tested By	Jisyong Wang

Antenna Polarity & Test Distance: Horizontal at 3 m										
Frequency (MHz)	Emission Level (dBuV/m)	Read Level (dBuV)	Limit (dBuV/m)	Margin (dB)	Antenna Factor (dB/m)	Cable Loss (dB)	Preamp Factor (dB)	Antenna Height (cm)	Table Angle (Degree)	Remark
5411.92	40.55	39.5	54	-13.45	31.75	6.48	37.18	141	194	Average
5411.92	54.14	53.09	74	-19.86	31.75	6.48	37.18	141	194	Peak
*5470	53.05	51.82	68.2	-15.15	31.79	6.52	37.08	141	194	Peak
5580	96.1	94.69			31.92	6.65	37.16	141	194	Average
5580	104.63	103.22			31.92	6.65	37.16	141	194	Peak
*5725	51.45	49.94	68.2	-16.75	32.18	6.76	37.43	141	194	Peak
11160	47.46	49.16	54	-6.54	40.56	10.52	52.78	203	213	Average
11160	57.47	59.17	74	-16.53	40.56	10.52	52.78	203	213	Peak

Antenna Polarity & Test Distance: Vertical at 3 m										
Frequency (MHz)	Emission Level (dBuV/m)	Read Level (dBuV)	Limit (dBuV/m)	Margin (dB)	Antenna Factor (dB/m)	Cable Loss (dB)	Preamp Factor (dB)	Antenna Height (cm)	Table Angle (Degree)	Remark
5424.08	46.88	45.82	54	-7.12	31.75	6.49	37.18	131	176	Average
5424.08	59.35	58.29	74	-14.65	31.75	6.49	37.18	131	176	Peak
*5470	57.95	56.72	68.2	-10.25	31.79	6.52	37.08	131	176	Peak
5580	104.1	102.69			31.92	6.65	37.16	131	176	Average
5580	112.65	111.24			31.92	6.65	37.16	131	176	Peak
*5725	54.05	52.54	68.2	-14.15	32.18	6.76	37.43	131	176	Peak
11160	48.89	50.59	54	-5.11	40.56	10.52	52.78	253	321	Average
11160	58.89	60.59	74	-15.11	40.56	10.52	52.78	253	321	Peak

Remarks:

- Emission Level = Read Level + Antenna Factor + Cable Loss - Preamp Factor
Margin value = Emission level – Limit value
- 5580 MHz: Fundamental Frequency
- *: Out of Restricted Band
- The emission levels of other frequencies were very low against the limit.

EUT Test Condition		Measurement Detail	
Channel	Channel 140	Frequency Range	1 GHz ~ 40 GHz
Input Power	120 Vac, 60 Hz	Detector Function	Peak (PK) Average (AV)
Environmental Conditions	25 deg. C, 65 % RH	Tested By	Jisyong Wang

Antenna Polarity & Test Distance: Horizontal at 3 m										
Frequency (MHz)	Emission Level (dBuV/m)	Read Level (dBuV)	Limit (dBuV/m)	Margin (dB)	Antenna Factor (dB/m)	Cable Loss (dB)	Preamp Factor (dB)	Antenna Height (cm)	Table Angle (Degree)	Remark
5364.88	38.88	37.87	54	-15.12	31.72	6.47	37.18	112	161	Average
5364.88	52.37	51.36	74	-21.63	31.72	6.47	37.18	112	161	Peak
*5470	50.76	49.53	68.2	-17.44	31.79	6.52	37.08	112	161	Peak
5700	91.07	89.62			32.12	6.73	37.4	112	161	Average
5700	99.83	98.38			32.12	6.73	37.4	112	161	Peak
*5725	55.79	54.28	68.2	-12.41	32.18	6.76	37.43	112	161	Peak
11400	47.35	49.25	54	-6.65	40.33	10.47	52.7	165	231	Average
11400	57.38	59.28	74	-16.62	40.33	10.47	52.7	165	231	Peak

Antenna Polarity & Test Distance: Vertical at 3 m										
Frequency (MHz)	Emission Level (dBuV/m)	Read Level (dBuV)	Limit (dBuV/m)	Margin (dB)	Antenna Factor (dB/m)	Cable Loss (dB)	Preamp Factor (dB)	Antenna Height (cm)	Table Angle (Degree)	Remark
5361.36	47.49	46.48	54	-6.51	31.72	6.47	37.18	130	172	Average
5361.36	60.14	59.13	74	-13.86	31.72	6.47	37.18	130	172	Peak
*5470	57.12	55.89	68.2	-11.08	31.79	6.52	37.08	130	172	Peak
5700	102.7	101.25			32.12	6.73	37.4	164	177	Average
5700	111.58	110.13			32.12	6.73	37.4	164	177	Peak
*5725	67.69	66.18	68.2	-0.51	32.18	6.76	37.43	130	172	Peak
11400	46.62	48.52	54	-7.38	40.33	10.47	52.7	165	231	Average
11400	56.72	58.62	74	-17.28	40.33	10.47	52.7	165	231	Peak

Remarks:

- Emission Level = Read Level + Antenna Factor + Cable Loss - Preamp Factor
Margin value = Emission level – Limit value
- 5700 MHz: Fundamental Frequency
- *: Out of Restricted Band
- The emission levels of other frequencies were very low against the limit.

EUT Test Condition		Measurement Detail	
Channel	Channel 149	Frequency Range	1 GHz ~ 40 GHz
Input Power	120 Vac, 60 Hz	Detector Function	Peak (PK) Average (AV)
Environmental Conditions	25 deg. C, 65 % RH	Tested By	Toby Tian

<Spurious Emission>

Antenna Polarity & Test Distance: Horizontal at 3 m										
Frequency (MHz)	Emission Level (dBuV/m)	Read Level (dBuV)	Limit (dBuV/m)	Margin (dB)	Antenna Factor (dB/m)	Cable Loss (dB)	Preamp Factor (dB)	Antenna Height (cm)	Table Angle (Degree)	Remark
5745	93.72	92.45			31.99	6.75	37.47	116	197	Average
5745	103.18	101.91			31.99	6.75	37.47	116	197	Peak
11490	44.03	46.92	54	-9.97	39.91	10.03	52.83	176	89	Average
11490	56.51	59.4	74	-17.49	39.91	10.03	52.83	176	89	Peak
Antenna Polarity & Test Distance: Vertical at 3 m										
Frequency (MHz)	Emission Level (dBuV/m)	Read Level (dBuV)	Limit (dBuV/m)	Margin (dB)	Antenna Factor (dB/m)	Cable Loss (dB)	Preamp Factor (dB)	Antenna Height (cm)	Table Angle (Degree)	Remark
5745	102.65	101.38			31.99	6.75	37.47	205	285	Average
5745	111.98	110.71			31.99	6.75	37.47	205	285	Peak
11490	44.27	47.16	54	-9.73	39.91	10.03	52.83	129	26	Average
11490	57.53	60.42	74	-16.47	39.91	10.03	52.83	129	26	Peak

<Out of Band Emission (OOBE)>

Antenna Polarity & Test Distance: Horizontal at 3 m										
Frequency (MHz)	Emission Level (dBuV/m)	Read Level (dBuV)	Limit (dBuV/m)	Margin (dB)	Antenna Factor (dB/m)	Cable Loss (dB)	Preamp Factor (dB)	Antenna Height (cm)	Table Angle (Degree)	Remark
5562.35	51.3	50.25	68.2	-16.9	31.68	6.49	37.12	116	197	Peak
5656.4	50.26	49.13	72.95	-22.69	31.85	6.62	37.34	116	197	Peak
5920.975	50.85	49.08	71.17	-20.32	32.26	7.01	37.5	116	197	Peak
5974.175	51.6	49.66	68.2	-16.6	32.37	7.08	37.51	116	197	Peak
Antenna Polarity & Test Distance: Vertical at 3 m										
Frequency (MHz)	Emission Level (dBuV/m)	Read Level (dBuV)	Limit (dBuV/m)	Margin (dB)	Antenna Factor (dB/m)	Cable Loss (dB)	Preamp Factor (dB)	Antenna Height (cm)	Table Angle (Degree)	Remark
5555.7	54.04	53.06	68.2	-14.16	31.68	6.42	37.12	205	285	Peak
5655.45	53.5	52.37	72.25	-18.75	31.85	6.62	37.34	205	285	Peak
5919.075	52.01	50.24	72.57	-20.56	32.26	7.01	37.5	205	285	Peak
5983.675	52.76	50.82	68.2	-15.44	32.37	7.08	37.51	205	285	Peak

Remarks:

- Emission Level = Read Level + Antenna Factor + Cable Loss - Preamp Factor
Margin value = Emission level – Limit value
- 5745 MHz: Fundamental Frequency
- *: Out of Restricted Band
- The emission levels of other frequencies were very low against the limit.

EUT Test Condition		Measurement Detail	
Channel	Channel 157	Frequency Range	1 GHz ~ 40 GHz
Input Power	120 Vac, 60 Hz	Detector Function	Peak (PK) Average (AV)
Environmental Conditions	25 deg. C, 65 % RH	Tested By	Toby Tian

<Spurious Emission>

Antenna Polarity & Test Distance: Horizontal at 3 m										
Frequency (MHz)	Emission Level (dBuV/m)	Read Level (dBuV)	Limit (dBuV/m)	Margin (dB)	Antenna Factor (dB/m)	Cable Loss (dB)	Preamp Factor (dB)	Antenna Height (cm)	Table Angle (Degree)	Remark
5785	93.78	92.46			32.04	6.82	37.54	118	199	Average
5785	103.26	101.94			32.04	6.82	37.54	118	199	Peak
11570	43.55	47.01	54	-10.45	39.78	10.09	53.33	182	98	Average
11570	55.98	59.44	74	-18.02	39.78	10.09	53.33	182	98	Peak
Antenna Polarity & Test Distance: Vertical at 3 m										
Frequency (MHz)	Emission Level (dBuV/m)	Read Level (dBuV)	Limit (dBuV/m)	Margin (dB)	Antenna Factor (dB/m)	Cable Loss (dB)	Preamp Factor (dB)	Antenna Height (cm)	Table Angle (Degree)	Remark
5785	103.09	101.77			32.04	6.82	37.54	206	287	Average
5785	112.25	110.93			32.04	6.82	37.54	206	287	Peak
11570	43.59	47.05	54	-10.41	39.78	10.09	53.33	120	34	Average
11570	55.98	59.44	74	-18.02	39.78	10.09	53.33	120	34	Peak

<Out of Band Emission (OOBE)>

Antenna Polarity & Test Distance: Horizontal at 3 m										
Frequency (MHz)	Emission Level (dBuV/m)	Read Level (dBuV)	Limit (dBuV/m)	Margin (dB)	Antenna Factor (dB/m)	Cable Loss (dB)	Preamp Factor (dB)	Antenna Height (cm)	Table Angle (Degree)	Remark
5580.875	50.84	49.8	68.2	-17.36	31.71	6.49	37.16	118	199	Peak
5658.775	50.62	49.49	74.72	-24.1	31.85	6.62	37.34	118	199	Peak
5921.45	50.87	49.1	70.82	-19.95	32.26	7.01	37.5	118	199	Peak
5979.875	51.64	49.7	68.2	-16.56	32.37	7.08	37.51	118	199	Peak
Antenna Polarity & Test Distance: Vertical at 3 m										
Frequency (MHz)	Emission Level (dBuV/m)	Read Level (dBuV)	Limit (dBuV/m)	Margin (dB)	Antenna Factor (dB/m)	Cable Loss (dB)	Preamp Factor (dB)	Antenna Height (cm)	Table Angle (Degree)	Remark
5599.4	53.91	52.81	68.2	-14.29	31.77	6.49	37.16	206	287	Peak
5656.4	53.39	52.26	72.95	-19.56	31.85	6.62	37.34	206	287	Peak
5920.025	52.48	50.71	71.87	-19.39	32.26	7.01	37.5	206	287	Peak
5990.8	52.75	50.72	68.2	-15.45	32.4	7.14	37.51	206	287	Peak

Remarks:

- Emission Level = Read Level + Antenna Factor + Cable Loss - Preamp Factor
Margin value = Emission level – Limit value
- 5785 MHz: Fundamental Frequency
- *: Out of Restricted Band
- The emission levels of other frequencies were very low against the limit.

EUT Test Condition		Measurement Detail	
Channel	Channel 165	Frequency Range	1 GHz ~ 40 GHz
Input Power	120 Vac, 60 Hz	Detector Function	Peak (PK) Average (AV)
Environmental Conditions	25 deg. C, 65 % RH	Tested By	Toby Tian

<Spurious Emission>

Antenna Polarity & Test Distance: Horizontal at 3 m										
Frequency (MHz)	Emission Level (dBuV/m)	Read Level (dBuV)	Limit (dBuV/m)	Margin (dB)	Antenna Factor (dB/m)	Cable Loss (dB)	Preamp Factor (dB)	Antenna Height (cm)	Table Angle (Degree)	Remark
5825	93.39	54.39			32.12	6.88	0	118	200	Average
5825	103.02	64.02			32.12	6.88	0	118	200	Peak
11650	43.45	47	54	-10.55	39.65	10.15	53.35	184	81	Average
11650	54.97	58.52	74	-19.03	39.65	10.15	53.35	184	81	Peak
Antenna Polarity & Test Distance: Vertical at 3 m										
Frequency (MHz)	Emission Level (dBuV/m)	Read Level (dBuV)	Limit (dBuV/m)	Margin (dB)	Antenna Factor (dB/m)	Cable Loss (dB)	Preamp Factor (dB)	Antenna Height (cm)	Table Angle (Degree)	Remark
5825	103.04	101.57			32.12	6.88	37.53	205	282	Average
5825	112.18	110.71			32.12	6.88	37.53	205	282	Peak
11650	43.81	47.36	54	-10.19	39.65	10.15	53.35	132	33	Average
11650	55.13	58.68	74	-18.87	39.65	10.15	53.35	132	33	Peak

<Out of Band Emission (OOBE)>

Antenna Polarity & Test Distance: Horizontal at 3 m										
Frequency (MHz)	Emission Level (dBuV/m)	Read Level (dBuV)	Limit (dBuV/m)	Margin (dB)	Antenna Factor (dB/m)	Cable Loss (dB)	Preamp Factor (dB)	Antenna Height (cm)	Table Angle (Degree)	Remark
5597.975	50.11	11.88	68.2	-18.09	31.74	6.49	0	118	200	Peak
5655.45	50.6	12.13	72.25	-21.65	31.85	6.62	0	118	200	Peak
5923.825	50.18	10.88	69.07	-18.89	32.29	7.01	0	118	200	Peak
5986.05	51.83	12.32	68.2	-16.37	32.37	7.14	0	118	200	Peak
Antenna Polarity & Test Distance: Vertical at 3 m										
Frequency (MHz)	Emission Level (dBuV/m)	Read Level (dBuV)	Limit (dBuV/m)	Margin (dB)	Antenna Factor (dB/m)	Cable Loss (dB)	Preamp Factor (dB)	Antenna Height (cm)	Table Angle (Degree)	Remark
5560.45	53.41	15.24	68.2	-14.79	31.68	6.49	0	205	282	Peak
5652.6	54.14	15.67	70.13	-15.99	31.85	6.62	0	205	282	Peak
5920.025	51.87	12.6	71.87	-20	32.26	7.01	0	205	282	Peak
6007.425	52.69	13.1	68.2	-15.51	32.45	7.14	0	205	282	Peak

Remarks:

- Emission Level = Read Level + Antenna Factor + Cable Loss - Preamp Factor
Margin value = Emission level – Limit value
- 5825 MHz: Fundamental Frequency
- *: Out of Restricted Band
- The emission levels of other frequencies were very low against the limit.

802.11n (HT40)

EUT Test Condition		Measurement Detail	
Channel	Channel 38	Frequency Range	1 GHz ~ 40 GHz
Input Power	120 Vac, 60 Hz	Detector Function	Peak (PK) Average (AV)
Environmental Conditions	25 deg. C, 65 % RH	Tested By	Toby Tian

Antenna Polarity & Test Distance: Horizontal at 3 m

Frequency (MHz)	Emission Level (dBuV/m)	Read Level (dBuV)	Limit (dBuV/m)	Margin (dB)	Antenna Factor (dB/m)	Cable Loss (dB)	Preamp Factor (dB)	Antenna Height (cm)	Table Angle (Degree)	Remark
5032	42.33	42.19	54	-11.67	31.23	6.15	37.24	148	26	Average
5032	58.71	58.57	74	-15.29	31.23	6.15	37.24	148	26	Peak
5190	82.62	82.39			31.35	6.22	37.34	148	26	Average
5190	91.52	91.29			31.35	6.22	37.34	148	26	Peak
5446	38.7	37.93	54	-15.3	31.56	6.34	37.13	148	26	Average
5446	59.47	58.7	74	-14.53	31.56	6.34	37.13	148	26	Peak
*10380	55.72	59.71	68.2	-12.48	39.21	9.05	52.25	100	195	Peak

Antenna Polarity & Test Distance: Vertical at 3 m

Frequency (MHz)	Emission Level (dBuV/m)	Read Level (dBuV)	Limit (dBuV/m)	Margin (dB)	Antenna Factor (dB/m)	Cable Loss (dB)	Preamp Factor (dB)	Antenna Height (cm)	Table Angle (Degree)	Remark
5144	52.08	51.88	54	-1.92	31.32	6.2	37.32	217	279	Average
5144	64.49	64.29	74	-9.51	31.32	6.2	37.32	217	279	Peak
5190	98.39	98.16			31.35	6.22	37.34	217	279	Average
5190	106.99	106.76			31.35	6.22	37.34	217	279	Peak
5362	41.36	40.74	54	-12.64	31.49	6.31	37.18	217	279	Average
5362	60.44	59.82	74	-13.56	31.49	6.31	37.18	217	279	Peak
*10380	55.08	59.07	68.2	-13.12	39.21	9.05	52.25	100	177	Peak

Remarks:

- Emission Level = Read Level + Antenna Factor + Cable Loss - Preamp Factor
Margin value = Emission level – Limit value
- 5190 MHz: Fundamental Frequency
- *: Out of Restricted Band
- The emission levels of other frequencies were very low against the limit.

EUT Test Condition		Measurement Detail	
Channel	Channel 46	Frequency Range	1 GHz ~ 40 GHz
Input Power	120 Vac, 60 Hz	Detector Function	Peak (PK) Average (AV)
Environmental Conditions	25 deg. C, 65 % RH	Tested By	Toby Tian

Antenna Polarity & Test Distance: Horizontal at 3 m										
Frequency (MHz)	Emission Level (dBuV/m)	Read Level (dBuV)	Limit (dBuV/m)	Margin (dB)	Antenna Factor (dB/m)	Cable Loss (dB)	Preamp Factor (dB)	Antenna Height (cm)	Table Angle (Degree)	Remark
5062	38.42	38.25	54	-15.58	31.25	6.17	37.25	148	24	Average
5062	59.26	59.09	74	-14.74	31.25	6.17	37.25	148	24	Peak
5230	86.54	86.23			31.39	6.24	37.32	148	24	Average
5230	94.01	93.7			31.39	6.24	37.32	148	24	Peak
5452	38.88	38.06	54	-15.12	31.56	6.34	37.08	148	24	Average
5452	60.46	59.64	74	-13.54	31.56	6.34	37.08	148	24	Peak
*10460	53.32	57.51	68.2	-14.88	39.32	9.09	52.6	100	181	Peak

Antenna Polarity & Test Distance: Vertical at 3 m										
Frequency (MHz)	Emission Level (dBuV/m)	Read Level (dBuV)	Limit (dBuV/m)	Margin (dB)	Antenna Factor (dB/m)	Cable Loss (dB)	Preamp Factor (dB)	Antenna Height (cm)	Table Angle (Degree)	Remark
5132	42.72	42.51	54	-11.28	31.31	6.2	37.3	220	280	Average
5132	60.45	60.24	74	-13.55	31.31	6.2	37.3	220	280	Peak
5230	102.3	101.99			31.39	6.24	37.32	220	280	Average
5230	110.29	109.98			31.39	6.24	37.32	220	280	Peak
5432	42.26	41.52	54	-11.74	31.55	6.32	37.13	220	280	Average
5432	60.5	59.76	74	-13.5	31.55	6.32	37.13	220	280	Peak
*10460	54.16	58.35	68.2	-14.04	39.32	9.09	52.6	100	208	Peak

Remarks:

- Emission Level = Read Level + Antenna Factor + Cable Loss - Preamp Factor
Margin value = Emission level – Limit value
- 5230 MHz: Fundamental Frequency
- *: Out of Restricted Band
- The emission levels of other frequencies were very low against the limit.

EUT Test Condition		Measurement Detail	
Channel	Channel 54	Frequency Range	1 GHz ~ 40 GHz
Input Power	120 Vac, 60 Hz	Detector Function	Peak (PK) Average (AV)
Environmental Conditions	25 deg. C, 65 % RH	Tested By	Jisyong Wang

Antenna Polarity & Test Distance: Horizontal at 3 m										
Frequency (MHz)	Emission Level (dBuV/m)	Read Level (dBuV)	Limit (dBuV/m)	Margin (dB)	Antenna Factor (dB/m)	Cable Loss (dB)	Preamp Factor (dB)	Antenna Height (cm)	Table Angle (Degree)	Remark
5026.28	38.28	37.81	54	-15.72	31.48	6.23	37.24	150	204	Average
5026.28	50.89	50.42	74	-23.11	31.48	6.23	37.24	150	204	Peak
5270	92.59	91.77			31.65	6.44	37.27	150	204	Average
5270	101.89	101.07			31.65	6.44	37.27	150	204	Peak
5418.53	39.04	37.99	54	-14.96	31.75	6.48	37.18	150	204	Average
5418.53	51.71	50.66	74	-22.29	31.75	6.48	37.18	150	204	Peak
*10540	56.65	59.5	68.2	-11.55	39.7	10.31	52.86	152	231	Peak
Antenna Polarity & Test Distance: Vertical at 3 m										
Frequency (MHz)	Emission Level (dBuV/m)	Read Level (dBuV)	Limit (dBuV/m)	Margin (dB)	Antenna Factor (dB/m)	Cable Loss (dB)	Preamp Factor (dB)	Antenna Height (cm)	Table Angle (Degree)	Remark
5134.1	43.25	42.68	54	-10.75	31.55	6.32	37.3	157	176	Average
5134.1	55.7	55.13	74	-18.3	31.55	6.32	37.3	157	176	Peak
5270	103.34	102.52			31.65	6.44	37.27	157	176	Average
5270	112.98	112.16			31.65	6.44	37.27	157	176	Peak
5401.37	44.17	43.14	54	-9.83	31.74	6.47	37.18	157	176	Average
5401.37	57.05	56.02	74	-16.95	31.74	6.47	37.18	157	176	Peak
*10540	55.17	58.02	68.2	-13.03	39.7	10.31	52.86	152	231	Peak

Remarks:

- Emission Level = Read Level + Antenna Factor + Cable Loss - Preamp Factor
Margin value = Emission level – Limit value
- 5270 MHz: Fundamental Frequency
- *: Out of Restricted Band
- The emission levels of other frequencies were very low against the limit.

EUT Test Condition		Measurement Detail	
Channel	Channel 62	Frequency Range	1 GHz ~ 40 GHz
Input Power	120 Vac, 60 Hz	Detector Function	Peak (PK) Average (AV)
Environmental Conditions	25 deg. C, 65 % RH	Tested By	Jisyong Wang

Antenna Polarity & Test Distance: Horizontal at 3 m										
Frequency (MHz)	Emission Level (dBuV/m)	Read Level (dBuV)	Limit (dBuV/m)	Margin (dB)	Antenna Factor (dB/m)	Cable Loss (dB)	Preamp Factor (dB)	Antenna Height (cm)	Table Angle (Degree)	Remark
5057.96	38.2	37.68	54	-15.8	31.51	6.26	37.25	150	201	Average
5057.96	50.9	50.38	74	-23.1	31.51	6.26	37.25	150	201	Peak
5310	89.1	88.15			31.68	6.46	37.19	150	201	Average
5310	97.98	97.03			31.68	6.46	37.19	150	201	Peak
5350.77	42.81	41.82	54	-11.19	31.7	6.47	37.18	150	201	Average
5350.77	56.39	55.4	74	-17.61	31.7	6.47	37.18	150	201	Peak
10620	46.04	48.85	54	-7.96	39.89	10.39	53.09	152	231	Average
10620	56.01	58.82	74	-17.99	39.89	10.39	53.09	152	231	Peak

Antenna Polarity & Test Distance: Vertical at 3 m										
Frequency (MHz)	Emission Level (dBuV/m)	Read Level (dBuV)	Limit (dBuV/m)	Margin (dB)	Antenna Factor (dB/m)	Cable Loss (dB)	Preamp Factor (dB)	Antenna Height (cm)	Table Angle (Degree)	Remark
5140.4	42.6	42.01	54	-11.4	31.56	6.33	37.3	152	175	Average
5140.4	54.56	53.97	74	-19.44	31.56	6.33	37.3	152	175	Peak
5310	100.66	99.71			31.68	6.46	37.19	163	176	Average
5310	109.18	108.23			31.68	6.46	37.19	163	176	Peak
5350	52.86	51.87	54	-1.14	31.7	6.47	37.18	152	175	Average
5350	66.26	65.27	74	-7.74	31.7	6.47	37.18	152	175	Peak
10620	46.09	48.9	54	-7.91	39.89	10.39	53.09	251	231	Average
10620	56.13	58.94	74	-17.87	39.89	10.39	53.09	251	231	Peak

Remarks:

- Emission Level = Read Level + Antenna Factor + Cable Loss - Preamp Factor
Margin value = Emission level – Limit value
- 5310 MHz: Fundamental Frequency
- *: Out of Restricted Band
- The emission levels of other frequencies were very low against the limit.

EUT Test Condition		Measurement Detail	
Channel	Channel 102	Frequency Range	1 GHz ~ 40 GHz
Input Power	120 Vac, 60 Hz	Detector Function	Peak (PK) Average (AV)
Environmental Conditions	25 deg. C, 65 % RH	Tested By	Jisyong Wang

Antenna Polarity & Test Distance: Horizontal at 3 m										
Frequency (MHz)	Emission Level (dBuV/m)	Read Level (dBuV)	Limit (dBuV/m)	Margin (dB)	Antenna Factor (dB/m)	Cable Loss (dB)	Preamp Factor (dB)	Antenna Height (cm)	Table Angle (Degree)	Remark
5397.68	38.93	37.9	54	-15.07	31.74	6.47	37.18	144	166	Average
5397.68	51.8	50.77	74	-22.2	31.74	6.47	37.18	144	166	Peak
*5470	54.02	52.79	68.2	-14.18	31.79	6.52	37.08	144	166	Peak
5510	84.32	83.02			31.81	6.55	37.06	144	166	Average
5510	92.86	91.56			31.81	6.55	37.06	144	166	Peak
*5725	51.17	49.66	68.2	-17.03	32.18	6.76	37.43	144	166	Peak
11020	46.72	48.55	54	-7.28	40.71	10.41	52.95	152	211	Average
11020	56.72	58.55	74	-17.28	40.71	10.41	52.95	152	211	Peak

Antenna Polarity & Test Distance: Vertical at 3 m										
Frequency (MHz)	Emission Level (dBuV/m)	Read Level (dBuV)	Limit (dBuV/m)	Margin (dB)	Antenna Factor (dB/m)	Cable Loss (dB)	Preamp Factor (dB)	Antenna Height (cm)	Table Angle (Degree)	Remark
5460	45.33	44.13	54	-8.67	31.77	6.51	37.08	166	176	Average
5460	59.57	58.37	74	-14.43	31.77	6.51	37.08	166	176	Peak
*5470	66.92	65.69	68.2	-1.28	31.79	6.52	37.08	166	176	Peak
5510	98.61	97.31			31.81	6.55	37.06	147	171	Average
5510	107.36	106.06			31.81	6.55	37.06	147	171	Peak
*5725	51.08	49.57	68.2	-17.12	32.18	6.76	37.43	166	176	Peak
11020	47.37	49.2	54	-6.63	40.71	10.41	52.95	152	231	Average
11020	57.37	59.2	74	-16.63	40.71	10.41	52.95	152	231	Peak

Remarks:

- Emission Level = Read Level + Antenna Factor + Cable Loss - Preamp Factor
Margin value = Emission level – Limit value
- 5510 MHz: Fundamental Frequency
- *: Out of Restricted Band
- The emission levels of other frequencies were very low against the limit.

EUT Test Condition		Measurement Detail	
Channel	Channel 110	Frequency Range	1 GHz ~ 40 GHz
Input Power	120 Vac, 60 Hz	Detector Function	Peak (PK) Average (AV)
Environmental Conditions	25 deg. C, 65 % RH	Tested By	Jisyong Wang

Antenna Polarity & Test Distance: Horizontal at 3 m										
Frequency (MHz)	Emission Level (dBuV/m)	Read Level (dBuV)	Limit (dBuV/m)	Margin (dB)	Antenna Factor (dB/m)	Cable Loss (dB)	Preamp Factor (dB)	Antenna Height (cm)	Table Angle (Degree)	Remark
5427.76	39.23	38.12	54	-14.77	31.75	6.49	37.13	133	152	Average
5427.76	52.23	51.12	74	-21.77	31.75	6.49	37.13	133	152	Peak
*5470	51.71	50.48	68.2	-16.49	31.79	6.52	37.08	133	152	Peak
5550	87.46	86.05			31.89	6.61	37.09	133	152	Average
5550	96.1	94.69			31.89	6.61	37.09	133	152	Peak
*5725	50.92	49.41	68.2	-17.28	32.18	6.76	37.43	133	152	Peak
11100	46.55	48.16	54	-7.45	40.63	10.47	52.71	251	123	Average
11100	56.55	58.16	74	-17.45	40.63	10.47	52.71	251	123	Peak

Antenna Polarity & Test Distance: Vertical at 3 m										
Frequency (MHz)	Emission Level (dBuV/m)	Read Level (dBuV)	Limit (dBuV/m)	Margin (dB)	Antenna Factor (dB/m)	Cable Loss (dB)	Preamp Factor (dB)	Antenna Height (cm)	Table Angle (Degree)	Remark
5395.6	46.24	45.21	54	-7.76	31.74	6.47	37.18	132	192	Average
5395.6	59.54	58.51	74	-14.46	31.74	6.47	37.18	132	192	Peak
*5470	58.4	57.17	68.2	-9.8	31.79	6.52	37.08	132	192	Peak
5550	101.75	100.34			31.89	6.61	37.09	132	192	Average
5550	110.6	109.19			31.89	6.61	37.09	132	192	Peak
*5725	53.24	51.73	68.2	-14.96	32.18	6.76	37.43	132	192	Peak
11100	47.24	48.85	54	-6.76	40.63	10.47	52.71	251	123	Average
11100	57.23	58.84	74	-16.77	40.63	10.47	52.71	251	123	Peak

Remarks:

- Emission Level = Read Level + Antenna Factor + Cable Loss - Preamp Factor
Margin value = Emission level – Limit value
- 5550 MHz: Fundamental Frequency
- *: Out of Restricted Band
- The emission levels of other frequencies were very low against the limit.

EUT Test Condition		Measurement Detail	
Channel	Channel 134	Frequency Range	1 GHz ~ 40 GHz
Input Power	120 Vac, 60 Hz	Detector Function	Peak (PK) Average (AV)
Environmental Conditions	25 deg. C, 65 % RH	Tested By	Jisyong Wang

Antenna Polarity & Test Distance: Horizontal at 3 m										
Frequency (MHz)	Emission Level (dBuV/m)	Read Level (dBuV)	Limit (dBuV/m)	Margin (dB)	Antenna Factor (dB/m)	Cable Loss (dB)	Preamp Factor (dB)	Antenna Height (cm)	Table Angle (Degree)	Remark
5410.96	38.93	37.89	54	-15.07	31.74	6.48	37.18	109	131	Average
5410.96	52.58	51.54	74	-21.42	31.74	6.48	37.18	109	131	Peak
*5470	50.65	49.42	68.2	-17.55	31.79	6.52	37.08	109	131	Peak
5670	87.77	86.3			32.09	6.72	37.34	109	131	Average
5670	96.17	94.7			32.09	6.72	37.34	109	131	Peak
*5725	52.15	50.64	68.2	-16.05	32.18	6.76	37.43	109	131	Peak
11340	47.72	49.52	54	-6.28	40.4	10.52	52.72	152	231	Average
11340	57.76	59.56	74	-16.24	40.4	10.52	52.72	152	231	Peak

Antenna Polarity & Test Distance: Vertical at 3 m										
Frequency (MHz)	Emission Level (dBuV/m)	Read Level (dBuV)	Limit (dBuV/m)	Margin (dB)	Antenna Factor (dB/m)	Cable Loss (dB)	Preamp Factor (dB)	Antenna Height (cm)	Table Angle (Degree)	Remark
5371.28	45.61	44.6	54	-8.39	31.72	6.47	37.18	141	188	Average
5371.28	58.65	57.64	74	-15.35	31.72	6.47	37.18	141	188	Peak
*5470	56.79	55.56	68.2	-11.41	31.79	6.52	37.08	141	188	Peak
5670	101.29	99.82			32.09	6.72	37.34	145	174	Average
5670	110.23	108.76			32.09	6.72	37.34	145	174	Peak
*5725	58.01	56.5	68.2	-10.19	32.18	6.76	37.43	141	188	Peak
11340	47.72	49.52	54	-6.28	40.4	10.52	52.72	252	231	Average
11340	57.72	59.52	74	-16.28	40.4	10.52	52.72	252	231	Peak

Remarks:

- Emission Level = Read Level + Antenna Factor + Cable Loss - Preamp Factor
Margin value = Emission level – Limit value
- 5670 MHz: Fundamental Frequency
- *: Out of Restricted Band
- The emission levels of other frequencies were very low against the limit.

EUT Test Condition		Measurement Detail	
Channel	Channel 151	Frequency Range	1 GHz ~ 40 GHz
Input Power	120 Vac, 60 Hz	Detector Function	Peak (PK) Average (AV)
Environmental Conditions	25 deg. C, 65 % RH	Tested By	Toby Tian

<Spurious Emission>

Antenna Polarity & Test Distance: Horizontal at 3 m										
Frequency (MHz)	Emission Level (dBuV/m)	Read Level (dBuV)	Limit (dBuV/m)	Margin (dB)	Antenna Factor (dB/m)	Cable Loss (dB)	Preamp Factor (dB)	Antenna Height (cm)	Table Angle (Degree)	Remark
5775	91.1	89.74			32.04	6.82	37.5	115	198	Average
5775	100.66	99.3			32.04	6.82	37.5	115	198	Peak
11510	43.75	46.89	54	-10.25	39.9	10.03	53.07	183	91	Average
11510	56.4	59.54	74	-17.6	39.9	10.03	53.07	183	91	Peak
Antenna Polarity & Test Distance: Vertical at 3 m										
Frequency (MHz)	Emission Level (dBuV/m)	Read Level (dBuV)	Limit (dBuV/m)	Margin (dB)	Antenna Factor (dB/m)	Cable Loss (dB)	Preamp Factor (dB)	Antenna Height (cm)	Table Angle (Degree)	Remark
5775	100.37	99.01			32.04	6.82	37.5	206	285	Average
5775	109.69	108.33			32.04	6.82	37.5	206	285	Peak
11510	43.96	47.1	54	-10.04	39.9	10.03	53.07	115	21	Average
11510	55.64	58.78	74	-18.36	39.9	10.03	53.07	115	21	Peak

<Out of Band Emission (OOBE)>

Antenna Polarity & Test Distance: Horizontal at 3 m										
Frequency (MHz)	Emission Level (dBuV/m)	Read Level (dBuV)	Limit (dBuV/m)	Margin (dB)	Antenna Factor (dB/m)	Cable Loss (dB)	Preamp Factor (dB)	Antenna Height (cm)	Table Angle (Degree)	Remark
5592.275	50.57	49.5	68.2	-17.63	31.74	6.49	37.16	115	198	Peak
5653.55	53.02	51.83	70.84	-17.82	31.85	6.62	37.28	115	198	Peak
5917.65	50.48	48.71	73.62	-23.14	32.26	7.01	37.5	115	198	Peak
6006.95	52.44	50.36	68.2	-15.76	32.45	7.14	37.51	115	198	Peak
Antenna Polarity & Test Distance: Vertical at 3 m										
Frequency (MHz)	Emission Level (dBuV/m)	Read Level (dBuV)	Limit (dBuV/m)	Margin (dB)	Antenna Factor (dB/m)	Cable Loss (dB)	Preamp Factor (dB)	Antenna Height (cm)	Table Angle (Degree)	Remark
5576.6	52.79	51.71	68.2	-15.41	31.71	6.49	37.12	206	285	Peak
5653.075	51.61	50.42	70.49	-18.88	31.85	6.62	37.28	206	285	Peak
5921.925	51.28	49.48	70.47	-19.19	32.29	7.01	37.5	206	285	Peak
5970.85	51.98	50.07	68.2	-16.22	32.34	7.08	37.51	206	285	Peak

Remarks:

- Emission Level = Read Level + Antenna Factor + Cable Loss - Preamp Factor
Margin value = Emission level – Limit value
- 5755 MHz: Fundamental Frequency
- *: Out of Restricted Band
- The emission levels of other frequencies were very low against the limit.

EUT Test Condition		Measurement Detail	
Channel	Channel 159	Frequency Range	1 GHz ~ 40 GHz
Input Power	120 Vac, 60 Hz	Detector Function	Peak (PK) Average (AV)
Environmental Conditions	25 deg. C, 65 % RH	Tested By	Toby Tian

<Spurious Emission>

Antenna Polarity & Test Distance: Horizontal at 3 m										
Frequency (MHz)	Emission Level (dBuV/m)	Read Level (dBuV)	Limit (dBuV/m)	Margin (dB)	Antenna Factor (dB/m)	Cable Loss (dB)	Preamp Factor (dB)	Antenna Height (cm)	Table Angle (Degree)	Remark
5795	90.92	89.57			32.07	6.82	37.54	117	201	Average
5795	100.57	99.22			32.07	6.82	37.54	117	201	Peak
11590	43.47	46.97	54	-10.53	39.74	10.09	53.33	180	97	Average
11590	55.66	59.16	74	-18.34	39.74	10.09	53.33	180	97	Peak

Antenna Polarity & Test Distance: Vertical at 3 m										
Frequency (MHz)	Emission Level (dBuV/m)	Read Level (dBuV)	Limit (dBuV/m)	Margin (dB)	Antenna Factor (dB/m)	Cable Loss (dB)	Preamp Factor (dB)	Antenna Height (cm)	Table Angle (Degree)	Remark
5795	100.39	99.04			32.07	6.82	37.54	205	288	Average
5795	109.74	108.39			32.07	6.82	37.54	205	288	Peak
11590	43.82	47.32	54	-10.18	39.74	10.09	53.33	113	17	Average
11590	55.36	58.86	74	-18.64	39.74	10.09	53.33	113	17	Peak

<Out of Band Emission (OOBE)>

Antenna Polarity & Test Distance: Horizontal at 3 m										
Frequency (MHz)	Emission Level (dBuV/m)	Read Level (dBuV)	Limit (dBuV/m)	Margin (dB)	Antenna Factor (dB/m)	Cable Loss (dB)	Preamp Factor (dB)	Antenna Height (cm)	Table Angle (Degree)	Remark
5582.775	51.35	50.28	68.2	-16.85	31.74	6.49	37.16	117	201	Peak
5653.55	50.9	49.71	70.84	-19.94	31.85	6.62	37.28	117	201	Peak
5920.975	51.48	49.71	71.17	-19.69	32.26	7.01	37.5	117	201	Peak
6004.575	52.03	50	68.2	-16.17	32.4	7.14	37.51	117	201	Peak

Antenna Polarity & Test Distance: Vertical at 3 m										
Frequency (MHz)	Emission Level (dBuV/m)	Read Level (dBuV)	Limit (dBuV/m)	Margin (dB)	Antenna Factor (dB/m)	Cable Loss (dB)	Preamp Factor (dB)	Antenna Height (cm)	Table Angle (Degree)	Remark
5603.675	53.13	52.02	68.2	-15.07	31.77	6.56	37.22	205	288	Peak
5654.975	51.36	50.23	71.9	-20.54	31.85	6.62	37.34	205	288	Peak
5920.025	51.52	49.75	71.87	-20.35	32.26	7.01	37.5	205	288	Peak
6005.05	53.12	51.09	68.2	-15.08	32.4	7.14	37.51	205	288	Peak

Remarks:

- Emission Level = Read Level + Antenna Factor + Cable Loss - Preamp Factor
Margin value = Emission level – Limit value
- 5795 MHz: Fundamental Frequency
- *: Out of Restricted Band
- The emission levels of other frequencies were very low against the limit.

802.11ac (VHT80)

EUT Test Condition		Measurement Detail	
Channel	Channel 42	Frequency Range	1 GHz ~ 40 GHz
Input Power	120 Vac, 60 Hz	Detector Function	Peak (PK) Average (AV)
Environmental Conditions	25 deg. C, 65 % RH	Tested By	Toby Tian

Antenna Polarity & Test Distance: Horizontal at 3 m

Frequency (MHz)	Emission Level (dBuV/m)	Read Level (dBuV)	Limit (dBuV/m)	Margin (dB)	Antenna Factor (dB/m)	Cable Loss (dB)	Preamp Factor (dB)	Antenna Height (cm)	Table Angle (Degree)	Remark
5064	41.53	41.36	54	-12.47	31.25	6.17	37.25	156	24	Average
5064	60.5	60.33	74	-13.5	31.25	6.17	37.25	156	24	Peak
5210	79.83	79.58			31.37	6.24	37.36	156	24	Average
5210	88.57	88.32			31.37	6.24	37.36	156	24	Peak
5450	39.81	38.99	54	-14.19	31.56	6.34	37.08	156	24	Average
5450	59.92	59.1	74	-14.08	31.56	6.34	37.08	156	24	Peak
*10420	55.94	59.94	68.2	-12.26	39.27	9.09	52.36	100	186	Peak

Antenna Polarity & Test Distance: Vertical at 3 m

Frequency (MHz)	Emission Level (dBuV/m)	Read Level (dBuV)	Limit (dBuV/m)	Margin (dB)	Antenna Factor (dB/m)	Cable Loss (dB)	Preamp Factor (dB)	Antenna Height (cm)	Table Angle (Degree)	Remark
5142	52.44	52.22	54	-1.56	31.32	6.2	37.3	220	279	Average
5142	63.23	63.01	74	-10.77	31.32	6.2	37.3	220	279	Peak
5210	91.65	91.4			31.37	6.24	37.36	220	279	Average
5210	101.83	101.58			31.37	6.24	37.36	220	279	Peak
5424	39.71	39.04	54	-14.29	31.53	6.32	37.18	220	279	Average
5424	60.84	60.17	74	-13.16	31.53	6.32	37.18	220	279	Peak
*10420	55.34	59.34	68.2	-12.86	39.27	9.09	52.36	100	254	Peak

Remarks:

- Emission Level = Read Level + Antenna Factor + Cable Loss - Preamp Factor
Margin value = Emission level – Limit value
- 5210 MHz: Fundamental Frequency
- *: Out of Restricted Band
- The emission levels of other frequencies were very low against the limit.

EUT Test Condition		Measurement Detail	
Channel	Channel 58	Frequency Range	1 GHz ~ 40 GHz
Input Power	120 Vac, 60 Hz	Detector Function	Peak (PK) Average (AV)
Environmental Conditions	25 deg. C, 65 % RH	Tested By	Jisyong Wang

Antenna Polarity & Test Distance: Horizontal at 3 m										
Frequency (MHz)	Emission Level (dBuV/m)	Read Level (dBuV)	Limit (dBuV/m)	Margin (dB)	Antenna Factor (dB/m)	Cable Loss (dB)	Preamp Factor (dB)	Antenna Height (cm)	Table Angle (Degree)	Remark
5017.64	38.15	37.7	54	-15.85	31.47	6.22	37.24	130	152	Average
5017.64	51.38	50.93	74	-22.62	31.47	6.22	37.24	130	152	Peak
5290	81.36	80.48			31.66	6.45	37.23	130	152	Average
5290	90.09	89.21			31.66	6.45	37.23	130	152	Peak
5357.15	41.87	40.88	54	-12.13	31.7	6.47	37.18	130	152	Average
5357.15	55.17	54.18	74	-18.83	31.7	6.47	37.18	130	152	Peak
*10580	56.46	59.37	68.2	-11.74	39.81	10.39	53.11	125	123	Peak

Antenna Polarity & Test Distance: Vertical at 3 m										
Frequency (MHz)	Emission Level (dBuV/m)	Read Level (dBuV)	Limit (dBuV/m)	Margin (dB)	Antenna Factor (dB/m)	Cable Loss (dB)	Preamp Factor (dB)	Antenna Height (cm)	Table Angle (Degree)	Remark
5131.76	40.75	40.18	54	-13.25	31.55	6.32	37.3	144	190	Average
5131.76	53.66	53.09	74	-20.34	31.55	6.32	37.3	144	190	Peak
5290	93.34	92.46			31.66	6.45	37.23	153	173	Average
5290	102.16	101.28			31.66	6.45	37.23	153	173	Peak
5350	53.02	52.03	54	-0.98	31.7	6.47	37.18	144	190	Average
5350	66.48	65.49	74	-7.52	31.7	6.47	37.18	144	190	Peak
*10580	56.2	59.11	68.2	-12	39.81	10.39	53.11	256	321	Peak

Remarks:

- Emission Level = Read Level + Antenna Factor + Cable Loss - Preamp Factor
Margin value = Emission level – Limit value
- 5290 MHz: Fundamental Frequency
- *: Out of Restricted Band
- The emission levels of other frequencies were very low against the limit.

EUT Test Condition		Measurement Detail	
Channel	Channel 106	Frequency Range	1 GHz ~ 40 GHz
Input Power	120 Vac, 60 Hz	Detector Function	Peak (PK) Average (AV)
Environmental Conditions	25 deg. C, 65 % RH	Tested By	Jisyong Wang

Antenna Polarity & Test Distance: Horizontal at 3 m										
Frequency (MHz)	Emission Level (dBuV/m)	Read Level (dBuV)	Limit (dBuV/m)	Margin (dB)	Antenna Factor (dB/m)	Cable Loss (dB)	Preamp Factor (dB)	Antenna Height (cm)	Table Angle (Degree)	Remark
5412.56	39.86	38.81	54	-14.14	31.75	6.48	37.18	128	142	Average
5412.56	52.69	51.64	74	-21.31	31.75	6.48	37.18	128	142	Peak
*5470	54.88	53.65	68.2	-13.32	31.79	6.52	37.08	128	142	Peak
5530	78.52	77.19			31.84	6.58	37.09	128	142	Average
5530	86.8	85.47			31.84	6.58	37.09	128	142	Peak
*5725	50.87	49.36	68.2	-17.33	32.18	6.76	37.43	128	142	Peak
11060	47.84	49.53	54	-6.16	40.66	10.44	52.79	125	231	Average
11060	57.46	59.15	74	-16.54	40.66	10.44	52.79	125	231	Peak

Antenna Polarity & Test Distance: Vertical at 3 m										
Frequency (MHz)	Emission Level (dBuV/m)	Read Level (dBuV)	Limit (dBuV/m)	Margin (dB)	Antenna Factor (dB/m)	Cable Loss (dB)	Preamp Factor (dB)	Antenna Height (cm)	Table Angle (Degree)	Remark
5460	51.13	49.93	54	-2.87	31.77	6.51	37.08	154	171	Average
5460	63.86	62.66	74	-10.14	31.77	6.51	37.08	154	171	Peak
*5470	66.09	64.86	68.2	-2.11	31.79	6.52	37.08	154	171	Peak
5530	92.77	91.44			31.84	6.58	37.09	149	171	Average
5530	101.59	100.26			31.84	6.58	37.09	149	171	Peak
*5725	52.34	50.83	68.2	-15.86	32.18	6.76	37.43	154	171	Peak
11060	46.95	48.64	54	-7.05	40.66	10.44	52.79	252	263	Average
11060	56.93	58.62	74	-17.07	40.66	10.44	52.79	252	263	Peak

Remarks:

- Emission Level = Read Level + Antenna Factor + Cable Loss - Preamp Factor
Margin value = Emission level – Limit value
- 5530 MHz: Fundamental Frequency
- *: Out of Restricted Band
- The emission levels of other frequencies were very low against the limit.

EUT Test Condition		Measurement Detail	
Channel	Channel 122	Frequency Range	1 GHz ~ 40 GHz
Input Power	120 Vac, 60 Hz	Detector Function	Peak (PK) Average (AV)
Environmental Conditions	25 deg. C, 65 % RH	Tested By	Jisyong Wang

Antenna Polarity & Test Distance: Horizontal at 3 m										
Frequency (MHz)	Emission Level (dBuV/m)	Read Level (dBuV)	Limit (dBuV/m)	Margin (dB)	Antenna Factor (dB/m)	Cable Loss (dB)	Preamp Factor (dB)	Antenna Height (cm)	Table Angle (Degree)	Remark
5457.36	39.29	38.09	54	-14.71	31.77	6.51	37.08	130	152	Average
5457.36	52.3	51.1	74	-21.7	31.77	6.51	37.08	130	152	Peak
*5470	51.47	50.24	68.2	-16.73	31.79	6.52	37.08	130	152	Peak
5610	85.41	83.97			31.98	6.68	37.22	130	152	Average
5610	94.25	92.81			31.98	6.68	37.22	130	152	Peak
*5725	51.37	49.86	68.2	-16.83	32.18	6.76	37.43	130	152	Peak
11220	47.15	48.9	54	-6.85	40.51	10.55	52.81	152	231	Average
11220	57.16	58.91	74	-16.84	40.51	10.55	52.81	152	231	Peak

Antenna Polarity & Test Distance: Vertical at 3 m										
Frequency (MHz)	Emission Level (dBuV/m)	Read Level (dBuV)	Limit (dBuV/m)	Margin (dB)	Antenna Factor (dB/m)	Cable Loss (dB)	Preamp Factor (dB)	Antenna Height (cm)	Table Angle (Degree)	Remark
5459.6	48.21	47.01	54	-5.79	31.77	6.51	37.08	134	190	Average
5459.6	61.18	59.98	74	-12.82	31.77	6.51	37.08	134	190	Peak
*5470	62.22	60.99	68.2	-5.98	31.79	6.52	37.08	134	190	Peak
5610	99.56	98.12			31.98	6.68	37.22	142	170	Average
5610	108.54	107.1			31.98	6.68	37.22	142	170	Peak
*5725	58.84	57.33	68.2	-9.36	32.18	6.76	37.43	134	190	Peak
11220	47.7	49.45	54	-6.3	40.51	10.55	52.81	152	231	Average
11220	57.71	59.46	74	-16.29	40.51	10.55	52.81	152	231	Peak

Remarks:

- Emission Level = Read Level + Antenna Factor + Cable Loss - Preamp Factor
Margin value = Emission level – Limit value
- 5610 MHz: Fundamental Frequency
- *: Out of Restricted Band
- The emission levels of other frequencies were very low against the limit.

EUT Test Condition		Measurement Detail	
Channel	Channel 155	Frequency Range	1 GHz ~ 40 GHz
Input Power	120 Vac, 60 Hz	Detector Function	Peak (PK) Average (AV)
Environmental Conditions	25 deg. C, 65 % RH	Tested By	Toby Tian

<Spurious Emission>

Antenna Polarity & Test Distance: Horizontal at 3 m										
Frequency (MHz)	Emission Level (dBuV/m)	Read Level (dBuV)	Limit (dBuV/m)	Margin (dB)	Antenna Factor (dB/m)	Cable Loss (dB)	Preamp Factor (dB)	Antenna Height (cm)	Table Angle (Degree)	Remark
5775	97.82	96.46			32.04	6.82	37.5	115	201	Average
5775	97.44	96.08			32.04	6.82	37.5	115	201	Peak
11550	43.55	46.89	54	-10.45	39.81	10.09	53.24	177	87	Average
11550	55.49	58.83	74	-18.51	39.81	10.09	53.24	177	87	Peak
Antenna Polarity & Test Distance: Vertical at 3 m										
Frequency (MHz)	Emission Level (dBuV/m)	Read Level (dBuV)	Limit (dBuV/m)	Margin (dB)	Antenna Factor (dB/m)	Cable Loss (dB)	Preamp Factor (dB)	Antenna Height (cm)	Table Angle (Degree)	Remark
5775	97.48	96.12			32.04	6.82	37.5	206	282	Average
5775	106.95	105.59			32.04	6.82	37.5	206	282	Peak
11550	43.75	47.09	54	-10.25	39.81	10.09	53.24	128	27	Average
11550	56.04	59.38	74	-17.96	39.81	10.09	53.24	128	27	Peak

<Out of Band Emission (OOBE)>

Antenna Polarity & Test Distance: Horizontal at 3 m										
Frequency (MHz)	Emission Level (dBuV/m)	Read Level (dBuV)	Limit (dBuV/m)	Margin (dB)	Antenna Factor (dB/m)	Cable Loss (dB)	Preamp Factor (dB)	Antenna Height (cm)	Table Angle (Degree)	Remark
5577.075	50.55	49.47	68.2	-17.65	31.71	6.49	37.12	115	201	Peak
5654.975	51.13	50	71.9	-20.77	31.85	6.62	37.34	115	201	Peak
5917.65	51.53	49.76	73.62	-22.09	32.26	7.01	37.5	115	201	Peak
5989.85	51.84	49.81	68.2	-16.36	32.4	7.14	37.51	115	201	Peak
Antenna Polarity & Test Distance: Vertical at 3 m										
Frequency (MHz)	Emission Level (dBuV/m)	Read Level (dBuV)	Limit (dBuV/m)	Margin (dB)	Antenna Factor (dB/m)	Cable Loss (dB)	Preamp Factor (dB)	Antenna Height (cm)	Table Angle (Degree)	Remark
5644.05	56.78	55.62	68.2	-11.42	31.82	6.62	37.28	206	282	Peak
5654.975	60.86	59.73	71.9	-11.04	31.85	6.62	37.34	206	282	Peak
5917.65	53.42	51.65	73.62	-20.2	32.26	7.01	37.5	206	282	Peak
5997.45	52.32	50.29	68.2	-15.88	32.4	7.14	37.51	206	282	Peak

Remarks:

- Emission Level = Read Level + Antenna Factor + Cable Loss - Preamp Factor
Margin value = Emission level – Limit value
- 5775 MHz: Fundamental Frequency
- *: Out of Restricted Band
- The emission levels of other frequencies were very low against the limit.

9 kHz ~ 30 MHz Data:

The amplitude of spurious emissions attenuated more than 20 dB below the permissible value is not required to be report.

30 MHz ~ 1 GHz Worst-Case Data:

802.11n (HT20)

EUT Test Condition		Measurement Detail	
Channel	Channel 140	Frequency Range	30 MHz ~ 1 GHz
Input Power	120 Vac, 60 Hz	Detector Function	Peak (PK) Quasi-peak (QP)
Environmental Conditions	25 deg. C, 65 % RH	Tested By	Jisyong Wang

Antenna Polarity & Test Distance: Horizontal at 3 m										
Frequency (MHz)	Emission Level (dBuV/m)	Read Level (dBuV)	Limit (dBuV/m)	Margin (dB)	Antenna Factor (dB/m)	Cable Loss (dB)	Preamp Factor (dB)	Antenna Height (cm)	Table Angle (Degree)	Remark
99.84	31.43	53.58	43.5	-12.07	9.06	0.75	31.96	102	222	Peak
166.77	34.05	52.72	43.5	-9.45	12.05	1.05	31.77	132	265	Peak
215.27	36.26	56.59	43.5	-7.24	10.01	1.31	31.65	142	214	Peak
335.55	34.99	51.19	46	-11.01	13.8	1.82	31.82	152	214	Peak
665.35	31.45	39.76	46	-14.55	20.4	3.16	31.87	152	236	Peak
876.81	29.28	34.1	46	-16.72	23.21	3.96	31.99	185	214	Peak
Antenna Polarity & Test Distance: Vertical at 3 m										
Frequency (MHz)	Emission Level (dBuV/m)	Read Level (dBuV)	Limit (dBuV/m)	Margin (dB)	Antenna Factor (dB/m)	Cable Loss (dB)	Preamp Factor (dB)	Antenna Height (cm)	Table Angle (Degree)	Remark
99.84	35.54	57.69	43.5	-7.96	9.06	0.75	31.96	251	123	Peak
141.55	35.77	54.05	43.5	-7.73	12.41	0.94	31.63	165	231	Peak
213.33	34.87	55.27	43.5	-8.63	9.93	1.3	31.63	111	185	Peak
431.58	31.75	45.6	46	-14.25	15.96	2.2	32.01	256	321	Peak
494.63	35.83	47.85	46	-10.17	17.21	2.47	31.7	152	214	Peak
938.89	29.89	33.92	46	-16.11	23.73	4.18	31.94	111	165	Peak

Remarks:

- Emission Level = Read Level + Antenna Factor + Cable Loss - Preamp Factor
Margin value = Emission level – Limit value
- The emission levels of other frequencies were very low against the limit.

4.2 Conducted Emission Measurement

4.2.1 Limits of Conducted Emission Measurement

Frequency (MHz)	Conducted Limit (dBuV)	
	Quasi-peak	Average
0.15 - 0.5	66 - 56	56 - 46
0.50 - 5.0	56	46
5.0 - 30.0	60	50

- Note: 1. The lower limit shall apply at the transition frequencies.
 2. The limit decreases in line with the logarithm of the frequency in the range of 0.15 to 0.50 MHz.

4.2.2 Test Instruments

Description & Manufacturer	Model No.	Serial No.	Date Of Calibration	Due Date Of Calibration
Test Receiver ROHDE & SCHWARZ	ESCI	100613	Nov. 21, 2016	Nov. 20, 2017
RF signal cable Woken	5D-FB	Cable-cond1-01	Dec. 22, 2016	Dec. 21, 2017
LISN ROHDE & SCHWARZ (EUT)	ESH3-Z5	835239/001	Mar. 10, 2017	Mar. 09, 2018
LISN ROHDE & SCHWARZ (Peripheral)	ESH3-Z5	100311	Jul. 28, 2016	Jul. 27, 2017
Software ADT	BV ADT_Cond_ V7.3.7.4	NA	NA	NA

- Note: 1. The calibration interval of the above test instruments is 12 months and the calibrations are traceable to NML/ROC and NIST/USA.
 2. The test was performed in HwaYa Shielded Room 1.
 3. The VCCI Site Registration No. is C-2040.

4.2.3 Test Procedures

- a. The EUT was placed 0.4 meters from the conducting wall of the shielded room with EUT being connected to the power mains through a line impedance stabilization network (LISN). Other support units were connected to the power mains through another LISN. The two LISNs provide 50 ohm/ 50uH of coupling impedance for the measuring instrument.
- b. Both lines of the power mains connected to the EUT were checked for maximum conducted interference.
- c. The frequency range from 150 kHz to 30 MHz was searched. Emission levels under (Limit -20 dB) was not recorded.

Note: All modes of operation were investigated and the worst-case emissions are reported.

4.2.4 Deviation from Test Standard

No deviation.

4.2.5 Test Setup

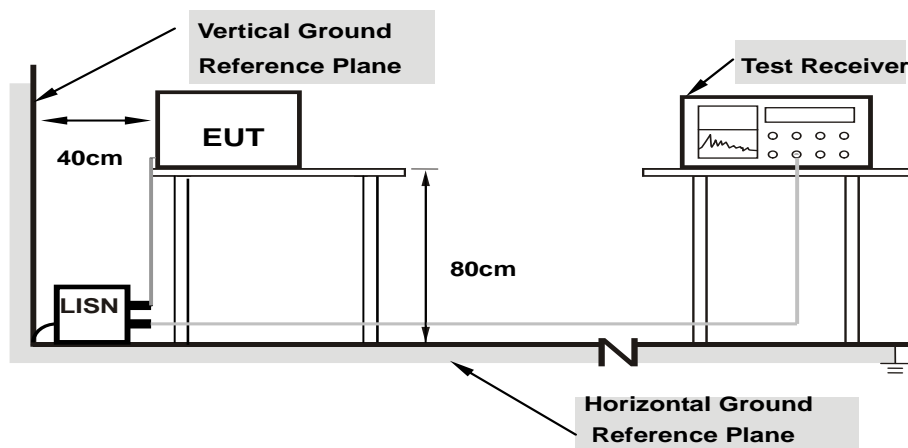

- Note:**
1. Support units were connected to second LISN.
 2. Both of LISNs (AMN) are 80 cm from EUT and at least 80 cm from other units and other metal planes

For the actual test configuration, please refer to the attached file (Test Setup Photo).

4.2.6 EUT Operating Conditions

- a. Placed the EUT on a testing table.
- b. Use the software to control the EUT under transmission condition continuously at specific channel frequency.

4.2.7 Test Results

Frequency Range	150kHz ~ 30MHz	Detector Function & Resolution Bandwidth	Quasi-Peak (QP) / Average (AV), 9kHz
Input Power	120Vac, 60Hz	Environmental Conditions	25°C, 65%RH
Tested by	Getaz Yang	Test Date	2017/6/21

Phase Of Power : Line (L)										
No	Frequency (MHz)	Correction Factor (dB)	Reading Value (dBuV)		Emission Level (dBuV)		Limit (dBuV)		Margin (dB)	
			Q.P.	AV.	Q.P.	AV.	Q.P.	AV.	Q.P.	AV.
1	0.15800	10.35	32.62	8.48	42.97	18.83	65.57	55.57	-22.60	-36.74
2	0.19000	10.36	30.79	16.91	41.15	27.27	64.04	54.04	-22.89	-26.77
3	0.77400	10.40	23.19	9.69	33.59	20.09	56.00	46.00	-22.41	-25.91
4	1.36600	10.42	22.51	12.59	32.93	23.01	56.00	46.00	-23.07	-22.99
5	2.83800	10.51	25.83	17.68	36.34	28.19	56.00	46.00	-19.66	-17.81
6	7.29400	10.71	21.31	14.81	32.02	25.52	60.00	50.00	-27.98	-24.48

Remarks:

1. Q.P. and AV. are abbreviations of quasi-peak and average individually.
2. The emission levels of other frequencies were very low against the limit.
3. Margin value = Emission level – Limit value
4. Correction factor = Insertion loss + Cable loss
5. Emission Level = Correction Factor + Reading Value

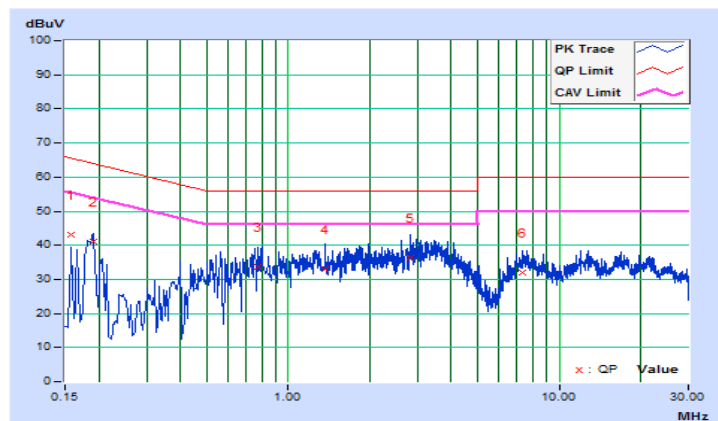

Frequency Range	150kHz ~ 30MHz	Detector Function & Resolution Bandwidth	Quasi-Peak (QP) / Average (AV), 9kHz
Input Power	120Vac, 60Hz	Environmental Conditions	25°C, 65%RH
Tested by	Getaz Yang	Test Date	2017/6/21

Phase Of Power : Neutral (N)										
No	Frequency (MHz)	Correction Factor (dB)	Reading Value (dBuV)		Emission Level (dBuV)		Limit (dBuV)		Margin (dB)	
			Q.P.	AV.	Q.P.	AV.	Q.P.	AV.	Q.P.	AV.
1	0.15400	10.11	33.06	8.25	43.17	18.36	65.78	55.78	-22.61	-37.42
2	0.28600	10.15	17.27	1.93	27.42	12.08	60.64	50.64	-33.22	-38.56
3	0.49800	10.16	22.42	10.69	32.58	20.85	56.03	46.03	-23.45	-25.18
4	0.90600	10.17	23.41	11.46	33.58	21.63	56.00	46.00	-22.42	-24.37
5	2.91000	10.28	26.36	18.29	36.64	28.57	56.00	46.00	-19.36	-17.43
6	3.91000	10.34	25.24	17.71	35.58	28.05	56.00	46.00	-20.42	-17.95

Remarks:

1. Q.P. and AV. are abbreviations of quasi-peak and average individually.
2. The emission levels of other frequencies were very low against the limit.
3. Margin value = Emission level – Limit value
4. Correction factor = Insertion loss + Cable loss
5. Emission Level = Correction Factor + Reading Value

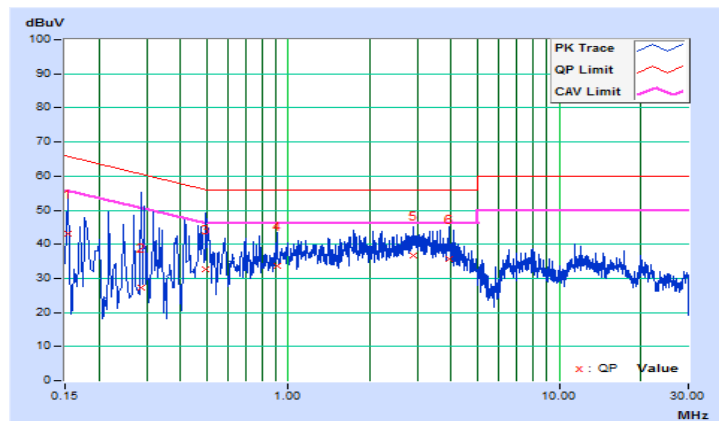

4.3 Transmit Power Measurement

4.3.1 Limits of Transmit Power Measurement

Operation Band	EUT Category		Limit
U-NII-1		Outdoor Access Point	1 Watt (30 dBm) (Max. e.i.r.p \leq 125 mW (21 dBm) at any elevation angle above 30 degrees as measured from the horizon)
		Fixed point-to-point Access Point	1 Watt (30 dBm)
		Indoor Access Point	1 Watt (30 dBm)
	√	Mobile and Portable client device	250 mW (24 dBm)
U-NII-2A		√	250 mW (24 dBm) or 11 dBm + 10 log B*
U-NII-2C		√	250 mW (24 dBm) or 11 dBm + 10 log B*
U-NII-3		√	1 Watt (30 dBm)

*B is the 26 dB emission bandwidth in megahertz

Per KDB 662911 Method of conducted output power measurement on IEEE 802.11 devices,

Array Gain = 0 dB (i.e., no array gain) for $N_{ANT} \leq 4$;

Array Gain = 0 dB (i.e., no array gain) for channel widths \geq 40 MHz for any N_{ANT} ;

Array Gain = $5 \log(N_{ANT}/N_{SS})$ dB or 3 dB, whichever is less for 20 MHz channel widths with $N_{ANT} \geq 5$.

For power measurements on all other devices: Array Gain = $10 \log(N_{ANT}/N_{SS})$ dB.

4.3.2 Test Setup

<Power Output Measurement>

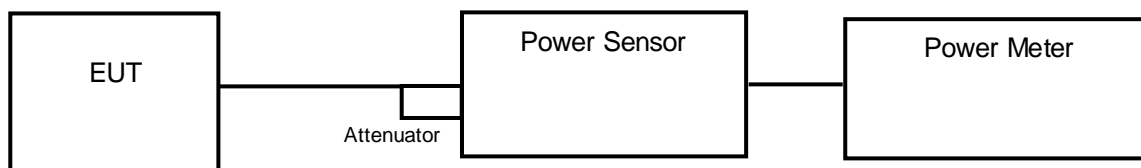

or

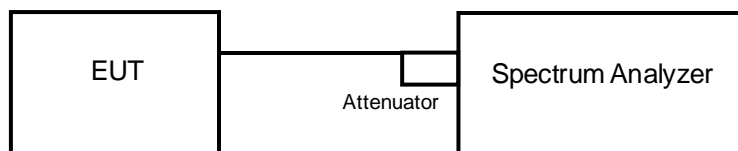

<26 dB Bandwidth>

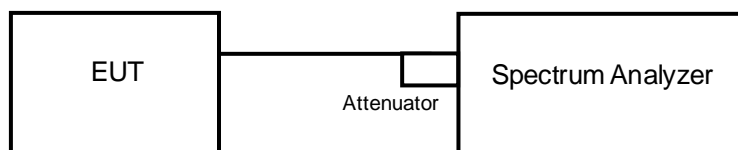

4.3.3 Test Instruments

Refer to section 4.1.2 to get information of above instrument.

4.3.4 Test Procedure

Average Power Measurement

<802.11a, 802.11n (HT20), 802.11n (HT40)>

Method PM is used to perform output power measurement, trigger and gating function of wide band power meter is enabled to measure max output power of TX on burst. Duty factor is not added to measured value.

<802.11ac (VHT80)>

- a. Set span to encompass the entire 26 dB EBW (or, alternatively, the entire 99% occupied bandwidth) of the signal.
- b. Set sweep trigger to "free run".
- c. Set RBW = 1 MHz.
- d. Set VBW \geq 3 MHz
- e. Number of points in sweep \geq 2 Span / RBW.
- f. Sweep time \leq (number of points in sweep) * T
- g. Using emission bandwidth to determine the frequency span for integration the channel bandwidth.
- h. Detector = RMS.
- i. Trace mode = max hold.
- j. Allow max hold to run for at least 60 seconds, or longer as needed to allow the trace to stabilize.

26 dB Bandwidth

- a. Set RBW = approximately 1 % of the emission bandwidth.
- b. Set the VBW > RBW.
- c. Detector = Peak.
- d. Trace mode = max hold.
- e. Measure the maximum width of the emission that is 26 dB down from the peak of the emission. Compare this with the RBW setting of the analyzer. Readjust RBW and repeat measurement as needed until the RBW/EBW ratio is approximately 1 %.

4.3.5 Deviation from Test Standard

No deviation.

4.3.6 EUT Operating Conditions

The software provided by client to enable the EUT under transmission condition continuously at lowest, middle and highest channel frequencies individually.

4.3.7 Test Result

Power Output:

802.11a

Channel	Frequency (MHz)	Maximum Conducted Power (mW)	Maximum Conducted Power (dBm)	Power Limit (dBm)	Pass / Fail
36	5180	126.183	21.01	24	Pass
44	5220	129.122	21.11	24	Pass
48	5240	127.35	21.05	24	Pass
52	5260	98.628	19.94	24	Pass
60	5300	94.189	19.74	24	Pass
64	5320	98.175	19.92	24	Pass
100	5500	98.628	19.94	24	Pass
116	5580	99.312	19.97	24	Pass
140	5700	97.949	19.91	24	Pass
149	5745	127.057	21.04	30	Pass
157	5785	136.773	21.36	30	Pass
165	5825	130.617	21.16	30	Pass

Note:

For U-NII-2A, U-NII-2C Band:

1. $11 \text{ dBm} + 10\log (35.33) = 26.48 \text{ dBm} > 24 \text{ dBm}$.
2. $11 \text{ dBm} + 10\log (34.62) = 26.39 \text{ dBm} > 24 \text{ dBm}$.
3. $11 \text{ dBm} + 10\log (36.20) = 26.59 \text{ dBm} > 24 \text{ dBm}$.
4. $11 \text{ dBm} + 10\log (38.21) = 26.82 \text{ dBm} > 24 \text{ dBm}$.
5. $11 \text{ dBm} + 10\log (38.33) = 26.84 \text{ dBm} > 24 \text{ dBm}$.
6. $11 \text{ dBm} + 10\log (34.12) = 26.33 \text{ dBm} > 24 \text{ dBm}$.

802.11n (HT20)

Channel	Frequency (MHz)	Maximum Conducted Power (dBm)		Total Power (mW)	Total Power (dBm)	Power Limit (dBm)	Pass / Fail
		Chain 0	Chain 1				
36	5180	19.51	18.92	167.314	22.24	24	Pass
44	5220	19.44	18.89	165.348	22.18	24	Pass
48	5240	19.26	19.07	165.057	22.18	24	Pass
52	5260	18.45	19.16	152.398	21.83	24	Pass
60	5300	18.43	18.96	148.368	21.71	24	Pass
64	5320	18.37	19.07	149.431	21.74	24	Pass
100	5500	18.65	18.89	150.728	21.78	24	Pass
116	5580	19.12	18.67	155.279	21.91	24	Pass
140	5700	16.89	16.83	97.06	19.87	24	Pass
149	5745	19.55	18.48	160.626	22.06	30	Pass
157	5785	19.73	18.67	167.593	22.24	30	Pass
165	5825	19.65	18.32	160.177	22.05	30	Pass

Note:

For U-NII-2A, U-NII-2C Band:

Chain 0

1. $11 \text{ dBm} + 10\log (27.71) = 25.43 \text{ dBm} > 24 \text{ dBm}$.
2. $11 \text{ dBm} + 10\log (28.76) = 25.59 \text{ dBm} > 24 \text{ dBm}$.
3. $11 \text{ dBm} + 10\log (28.55) = 25.56 \text{ dBm} > 24 \text{ dBm}$.
4. $11 \text{ dBm} + 10\log (31.76) = 26.02 \text{ dBm} > 24 \text{ dBm}$.
5. $11 \text{ dBm} + 10\log (37.32) = 26.72 \text{ dBm} > 24 \text{ dBm}$.
6. $11 \text{ dBm} + 10\log (24.66) = 24.92 \text{ dBm} > 24 \text{ dBm}$.

Chain 1

1. $11 \text{ dBm} + 10\log (31.56) = 25.99 \text{ dBm} > 24 \text{ dBm}$.
2. $11 \text{ dBm} + 10\log (41.14) = 27.14 \text{ dBm} > 24 \text{ dBm}$.
3. $11 \text{ dBm} + 10\log (33.38) = 26.23 \text{ dBm} > 24 \text{ dBm}$.
4. $11 \text{ dBm} + 10\log (25.19) = 25.01 \text{ dBm} > 24 \text{ dBm}$.
5. $11 \text{ dBm} + 10\log (24.46) = 24.88 \text{ dBm} > 24 \text{ dBm}$.
6. $11 \text{ dBm} + 10\log (22.88) = 24.59 \text{ dBm} > 24 \text{ dBm}$.

802.11n (HT40)

Channel	Frequency (MHz)	Maximum Conducted Power (dBm)		Total Power (mW)	Total Power (dBm)	Power Limit (dBm)	Pass / Fail
		Chain 0	Chain 1				
38	5190	15.48	15.34	69.516	18.42	24	Pass
46	5230	18.34	18.44	138.057	21.40	24	Pass
54	5270	17.35	18.40	123.508	20.92	24	Pass
62	5310	13.39	14.66	51.069	17.08	24	Pass
102	5510	14.03	15.12	57.802	17.62	24	Pass
110	5550	17.50	17.98	119.04	20.76	24	Pass
134	5670	17.45	18.06	119.563	20.78	24	Pass
151	5755	18.57	17.94	134.175	21.28	30	Pass
159	5795	18.97	17.84	139.7	21.45	30	Pass

Note:

For U-NII-2A, U-NII-2C Band:

Chain 0

1. $11 \text{ dBm} + 10\log (54.05) = 28.33 \text{ dBm} > 24 \text{ dBm}.$
2. $11 \text{ dBm} + 10\log (47.64) = 27.78 \text{ dBm} > 24 \text{ dBm}.$
3. $11 \text{ dBm} + 10\log (55.49) = 28.44 \text{ dBm} > 24 \text{ dBm}.$
4. $11 \text{ dBm} + 10\log (51.18) = 28.09 \text{ dBm} > 24 \text{ dBm}.$
5. $11 \text{ dBm} + 10\log (52.65) = 28.21 \text{ dBm} > 24 \text{ dBm}.$

Chain 1

1. $11 \text{ dBm} + 10\log (87.61) = 30.43 \text{ dBm} > 24 \text{ dBm}.$
2. $11 \text{ dBm} + 10\log (49.93) = 27.98 \text{ dBm} > 24 \text{ dBm}.$
3. $11 \text{ dBm} + 10\log (45.52) = 27.58 \text{ dBm} > 24 \text{ dBm}.$
4. $11 \text{ dBm} + 10\log (45.74) = 27.60 \text{ dBm} > 24 \text{ dBm}.$
5. $11 \text{ dBm} + 10\log (46.35) = 27.66 \text{ dBm} > 24 \text{ dBm}.$

802.11ac (VHT80)

Channel	Frequency (MHz)	Maximum Conducted Power (dBm)		Total Power (mW)	Total Power (dBm)	Power Limit (dBm)	Pass / Fail
		Chain 0	Chain 1				
42	5210	10.18	10.11	20.68	13.16	24	Pass
58	5290	14.58	15.60	65.016	18.13	24	Pass
106	5530	11.91	12.59	33.679	15.27	24	Pass
122	5610	18.10	18.52	135.686	21.33	24	Pass
155	5775	18.51	18.14	136.121	21.34	30	Pass

Note:

For U-NII-2A, U-NII-2C Band:

Chain 0

1. $11 \text{ dBm} + 10\log (91.22) = 30.60 \text{ dBm} > 24 \text{ dBm}$.
2. $11 \text{ dBm} + 10\log (89.08) = 30.50 \text{ dBm} > 24 \text{ dBm}$.
3. $11 \text{ dBm} + 10\log (158.96) = 33.01 \text{ dBm} > 24 \text{ dBm}$.

Chain 1

1. $11 \text{ dBm} + 10\log (134.11) = 32.27 \text{ dBm} > 24 \text{ dBm}$.
2. $11 \text{ dBm} + 10\log (86.68) = 30.38 \text{ dBm} > 24 \text{ dBm}$.
3. $11 \text{ dBm} + 10\log (93.90) = 30.73 \text{ dBm} > 24 \text{ dBm}$.

26 dB Bandwidth:
802.11a

Channel	Frequency (MHz)	26 dBc Bandwidth (MHz)
36	5180	45.00
44	5220	45.54
48	5240	45.68
52	5260	35.33
60	5300	34.62
64	5320	36.20
100	5500	38.21
116	5580	38.33
140	5700	34.12

802.11n (HT20)

Channel	Frequency (MHz)	26 dBc Bandwidth (MHz)	
		Chain 0	Chain 1
36	5180	44.44	41.90
44	5220	43.48	40.49
48	5240	44.48	39.23
52	5260	27.71	31.56
60	5300	28.76	41.14
64	5320	28.55	33.38
100	5500	31.76	25.19
116	5580	37.32	24.46
140	5700	24.66	22.88

802.11n (HT40)

Channel	Frequency (MHz)	26 dBc Bandwidth (MHz)	
		Chain 0	Chain 1
38	5190	60.58	53.46
46	5230	62.40	58.32
54	5270	54.05	87.61
62	5310	47.64	49.93
102	5510	55.49	45.52
110	5550	51.18	45.74
134	5670	52.65	46.35

802.11ac (VHT80)

Channel	Frequency (MHz)	26 dBc Bandwidth (MHz)	
		Chain 0	Chain 1
42	5210	89.33	89.64
58	5290	91.22	134.11
106	5530	89.08	86.68
122	5610	158.96	93.90

Spectrum Plot of Worst Value

802.11a

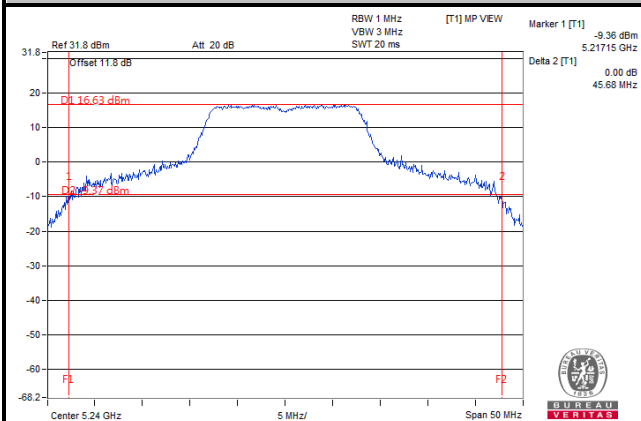

802.11n (HT20)

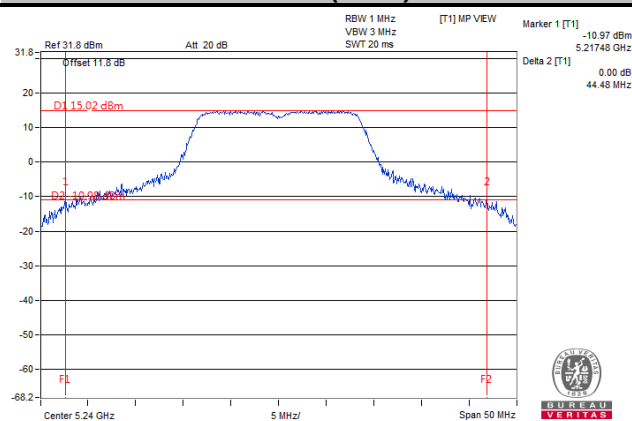

802.11n (HT40)

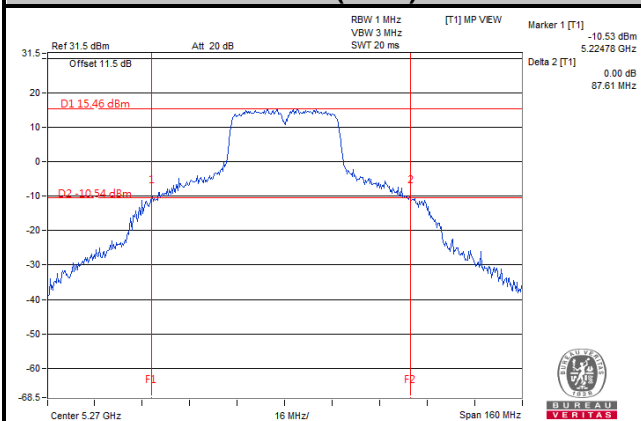

802.11ac (VHT80)

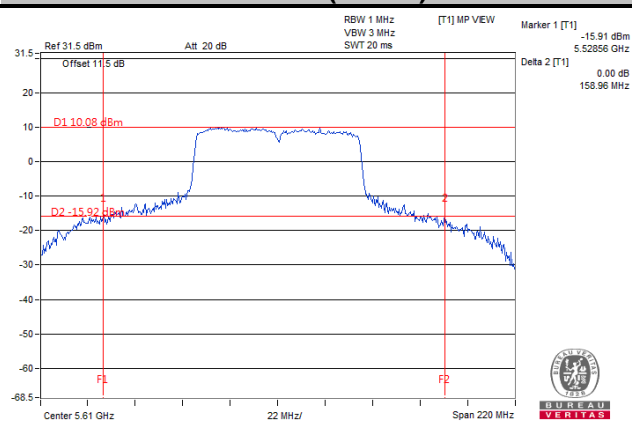

4.4 Occupied Bandwidth Measurement

4.4.1 Test Setup

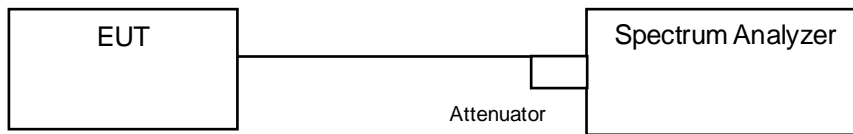

4.4.2 Test Instruments

Refer to section 4.1.2 to get information of above instrument.

4.4.3 Test Procedure

The transmitter output was connected to the spectrum analyzer through an attenuator. The bandwidth of the fundamental frequency was measured by spectrum analyzer with resolution bandwidth in the range of 1 % to 5 % of the anticipated emission bandwidth, and a video bandwidth at least 3x the resolution bandwidth and set the detector to SAMPLE. The width of a frequency band such that, below the lower and above the upper frequency limits, the mean powers emitted are each equal to a specified percentage 0.5 % of the total mean power of a given emission.

4.4.4 Test Results

802.11a

Channel	Channel Frequency (MHz)	Occupied Bandwidth (MHz)
36	5180	19.80
44	5220	20.67
48	5240	19.66
52	5260	18.48
60	5300	18.12
64	5320	18.48
100	5500	19.56
116	5580	19.92
140	5700	18.00
149	5745	20.43
157	5785	20.80
165	5825	19.60

802.11n (HT20)

Channel	Channel Frequency (MHz)	Occupied Bandwidth (MHz)	
		Chain 0	Chain 1
36	5180	18.79	18.36
44	5220	18.65	18.46
48	5240	18.70	18.26
52	5260	18.12	18.36
60	5300	18.12	18.60
64	5320	18.24	19.08
100	5500	18.36	18.00
116	5580	19.56	18.00
140	5700	18.00	17.88
149	5745	18.60	18.31
157	5785	18.75	18.30
165	5825	18.50	18.25

802.11n (HT40)

Channel	Channel Frequency (MHz)	Occupied Bandwidth (MHz)	
		Chain 0	Chain 1
38	5190	37.82	37.30
46	5230	37.82	37.30
54	5270	36.96	37.92
62	5310	36.96	36.96
102	5510	37.08	36.72
110	5550	37.08	36.72
134	5670	37.20	36.84
151	5755	37.50	37.17
159	5795	37.66	37.16

802.11ac (VHT80)

Channel	Channel Frequency (MHz)	Occupied Bandwidth (MHz)	
		Chain 0	Chain 1
42	5210	75.96	75.80
58	5290	76.08	76.80
106	5530	76.32	76.08
122	5610	76.32	75.84
155	5775	76.60	76.60

Spectrum Plot of Worst Value

802.11a

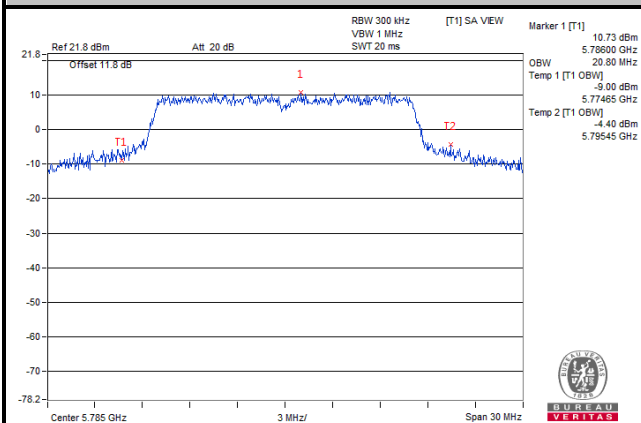

802.11n (HT20)

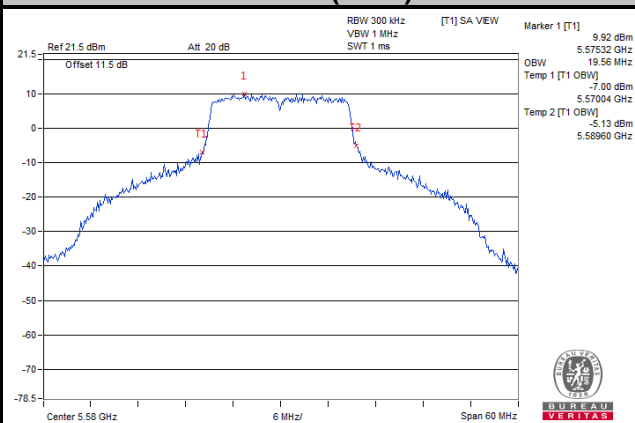

802.11n (HT40)

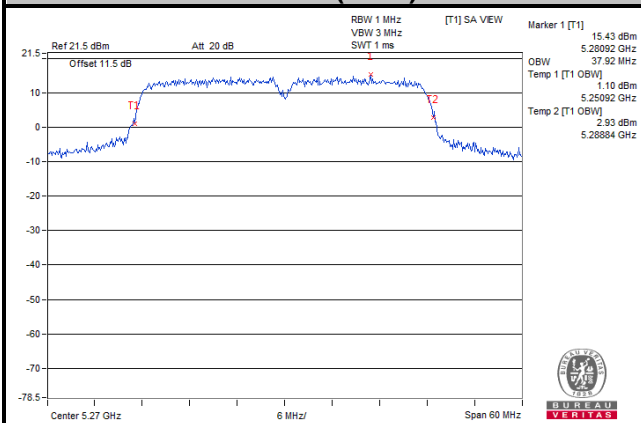

802.11ac (VHT80)

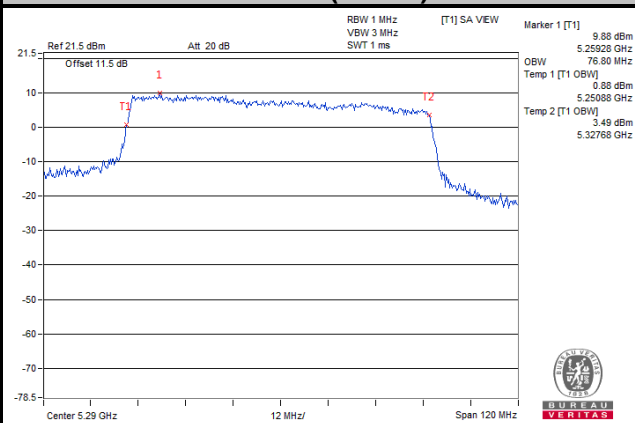

4.5 Peak Power Spectral Density Measurement

4.5.1 Limits of Peak Power Spectral Density Measurement

Operation Band	EUT Category		Limit
U-NII-1		Outdoor Access Point	17 dBm/MHz
		Fixed point-to-point Access Point	
		Indoor Access Point	
	√	Mobile and Portable client device	11 dBm/MHz
U-NII-2A		√	11 dBm/MHz
U-NII-2C		√	11 dBm/MHz
U-NII-3		√	30 dBm/500 kHz

4.5.2 Test Setup

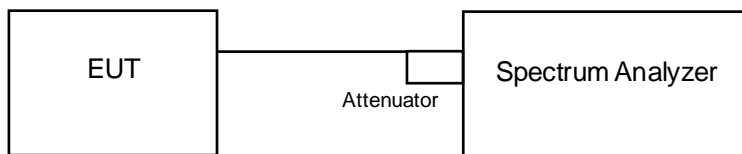

4.5.3 Test Instruments

Refer to section 4.1.3 to get information of above instrument.

4.5.4 Test Procedures

For U-NII-1, U-NII-2A, U-NII-2C band:

Using method SA-1

1. Set span to encompass the entire emission bandwidth (EBW) of the signal.
2. Set RBW = 1 MHz, Set VBW \geq 3 RBW, Detector = RMS
3. Sweep time = auto, trigger set to "free run".
4. Trace average at least 100 traces in power averaging mode.
5. Record the max value

※For U-NII-3:

1. Set span to encompass the entire emission bandwidth (EBW) of the signal.
2. Set RBW = 500 kHz, Set VBW \geq 3 RBW, Detector = RMS
3. Use the peak marker function to determine the maximum power level in any 500 kHz band segment within the fundamental EBW.
4. Sweep time = auto, trigger set to "free run".
5. Trace average at least 100 traces in power averaging mode.
6. Record the max value

4.5.5 Deviation from Test Standard

No deviation.

4.5.6 EUT Operating Conditions

The software provided by client to enable the EUT under transmission condition continuously at lowest, middle and highest channel frequencies individually.

4.5.7 Test Results

For U-NII-1, U-NII-2A, U-NII-2C Band

802.11a

Channel	Frequency (MHz)	PSD (dBm/MHz)	Maximum Limit (dBm/MHz)	Pass / Fail
36	5180	7.00	11	Pass
44	5220	7.47	11	Pass
48	5240	7.36	11	Pass
52	5260	7.97	11	Pass
60	5300	7.70	11	Pass
64	5320	7.99	11	Pass
100	5500	7.96	11	Pass
116	5580	8.25	11	Pass
140	5700	8.05	11	Pass

802.11n (HT20)

Channel	Frequency (MHz)	PSD (dBm/MHz)		Total Power Density (dBm/MHz)	Max. Limit (dBm/MHz)	Pass / Fail
		Chain 0	Chain 1			
36	5180	5.95	5.23	8.60	11	Pass
44	5220	5.72	5.63	8.66	11	Pass
48	5240	5.84	5.47	8.66	11	Pass
52	5260	5.49	6.75	9.18	11	Pass
60	5300	5.53	8.83	10.50	11	Pass
64	5320	5.71	7.98	10.00	11	Pass
100	5500	6.15	5.35	8.78	11	Pass
116	5580	7.22	4.74	9.16	11	Pass
140	5700	4.48	2.91	6.78	11	Pass

Note:

1. Method 1 of power density measurement of KDB 662911 is using for calculating total power density. Total power density is summing entire spectra across corresponding frequency bins on the various outputs by computer.

2. For U-NII-1 Band:

Directional gain = 2 dBi + 10log(2) = 5.31 dBi < 6 dBi, so the limit no need to reduced.

For U-NII-2A, U-NII-2C Band:

Directional gain = 2 dBi + 10log(2) = 5.31 dBi < 6 dBi, so the limit no need to reduced.

802.11n (HT40)

Channel	Frequency (MHz)	PSD (dBm/MHz)		Total Power Density (dBm/MHz)	Max. Limit (dBm/MHz)	Pass / Fail
		Chain 0	Chain 1			
38	5190	1.11	1.03	4.04	11	Pass
46	5230	1.34	1.57	4.44	11	Pass
54	5270	2.35	5.23	7.02	11	Pass
62	5310	-2.15	1.83	3.29	11	Pass
102	5510	2.65	-2.46	3.82	11	Pass
110	5550	2.63	0.96	4.89	11	Pass
134	5670	2.75	0.73	4.87	11	Pass

Note:

- Method 1 of power density measurement of KDB 662911 is using for calculating total power density. Total power density is summing entire spectra across corresponding frequency bins on the various outputs by computer.
- For U-NII-1 Band:**
Directional gain = 2 dBi + 10log(2) = 5.31 dBi < 6 dBi, so the limit no need to reduced.
- For U-NII-2A, U-NII-2C Band:**
Directional gain = 2 dBi + 10log(2) = 5.31 dBi < 6 dBi , so the limit no need to reduced.

802.11ac (VHT80):

Channel	Frequency (MHz)	PSD (dBm/MHz)		Total Power Density (dBm/MHz)	Max. Limit (dBm/MHz)	Pass / Fail
		Chain 0	Chain 1			
42	5210	-10.45	-10.52	-7.59	11	Pass
58	5290	0.34	-1.27	2.62	11	Pass
106	5530	-5.02	-8.58	-3.43	11	Pass
122	5610	1.20	-1.10	3.20	11	Pass

Note:

- Method 1 of power density measurement of KDB 662911 is using for calculating total power density. Total power density is summing entire spectra across corresponding frequency bins on the various outputs by computer.
- For U-NII-1 Band:**
Directional gain = 2 dBi + 10log(2) = 5.31 dBi < 6 dBi, so the limit no need to reduced.
- For U-NII-2A, U-NII-2C Band:**
Directional gain = 2 dBi + 10log(2) = 5.31 dBi < 6 dBi , so the limit no need to reduced.

Spectrum Plot of Worst Value

802.11a

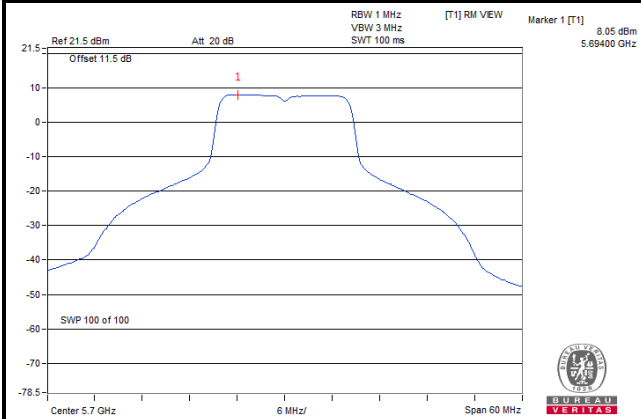

802.11n (HT20)

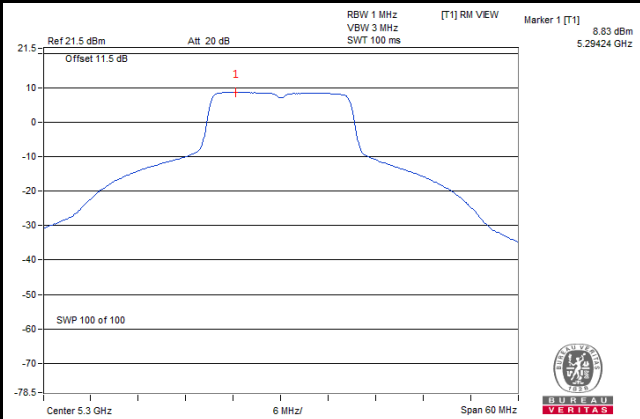

802.11n (HT40)

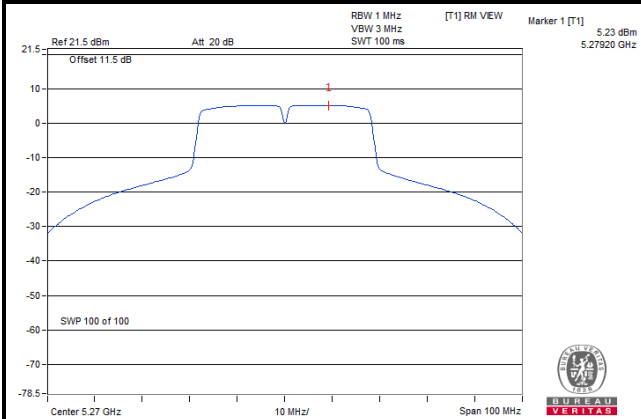

802.11ac (VHT80)

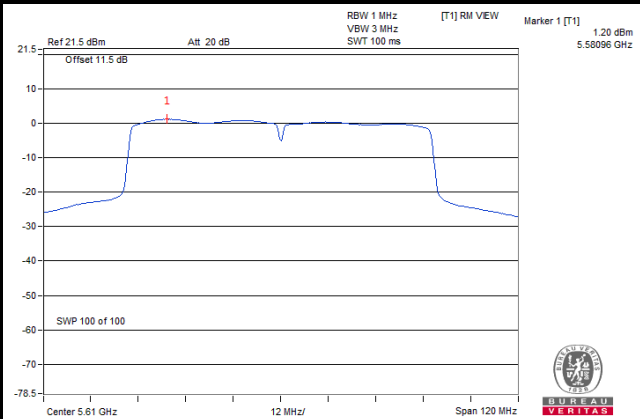

For U-NII-3 Band

802.11a

Channel	Freq. (MHz)	PSD (dBm/500 kHz)	Limit (dBm/500 kHz)	Pass / Fail
149	5745	4.61	30	Pass
157	5785	4.79	30	Pass
165	5825	4.91	30	Pass

802.11n (HT20)

TX Chain	Channel	Freq. (MHz)	PSD (dBm/500 kHz)	10 log (N=2) dB	Total PSD (dBm/500 kHz)	Limit (dBm/500 kHz)	Pass / Fail
0	149	5745	3.10	3.01	6.11	30	Pass
	157	5785	3.01	3.01	6.02	30	Pass
	165	5825	3.10	3.01	6.11	30	Pass
1	149	5745	2.79	3.01	5.80	30	Pass
	157	5785	3.07	3.01	6.08	30	Pass
	165	5825	3.20	3.01	6.21	30	Pass

Note: Directional gain = 2 dBi + 10log(2) = 5.01 dBi > 6 dBi, so the limit no need to reduced.

802.11n (HT40)

TX Chain	Channel	Freq. (MHz)	PSD (dBm/500 kHz)	10 log (N=2) dB	Total PSD (dBm/500 kHz)	Limit (dBm/500 kHz)	Pass / Fail
0	151	5755	-0.88	3.01	2.13	30	Pass
	159	5795	-0.24	3.01	2.77	30	Pass
1	151	5755	-0.91	3.01	2.10	30	Pass
	159	5795	-0.41	3.01	2.60	30	Pass

Note: Directional gain = 2 dBi + 10log(2) = 5.01 dBi > 6 dBi, so the limit no need to reduced.

802.11ac (VHT80)

TX Chain	Channel	Freq. (MHz)	PSD (dBm/500 kHz)	10 log (N=2) dB	Total PSD (dBm/500 kHz)	Limit (dBm/500 kHz)	Pass / Fail
0	155	5775	-2.90	3.01	0.11	30	Pass
1	155	5775	-3.14	3.01	-0.13	30	Pass

Note: Directional gain = 2 dBi + 10log(2) = 5.01 dBi > 6 dBi, so the limit no need to reduced.

Spectrum Plot of Worst Value

802.11a

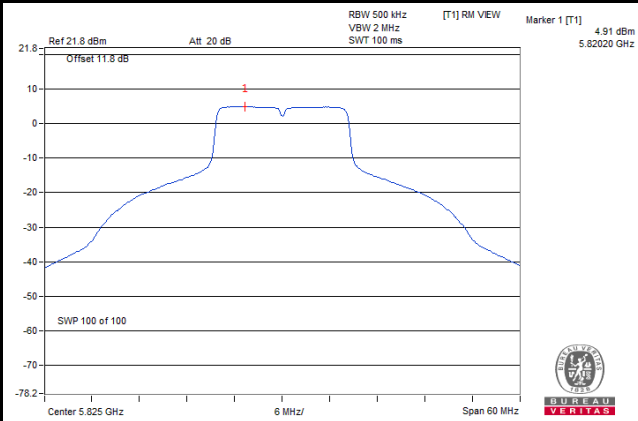

802.11n (HT20)

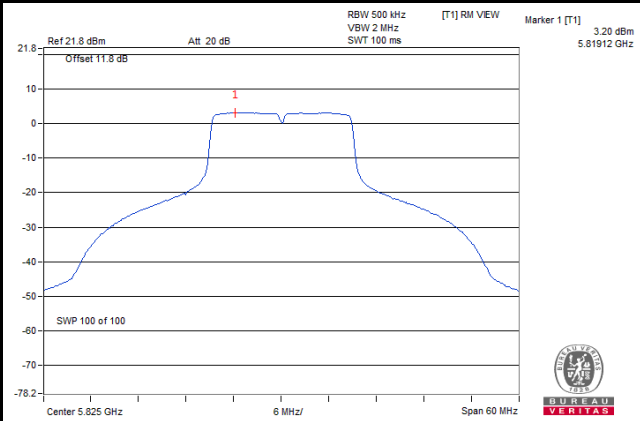

802.11n (HT40)

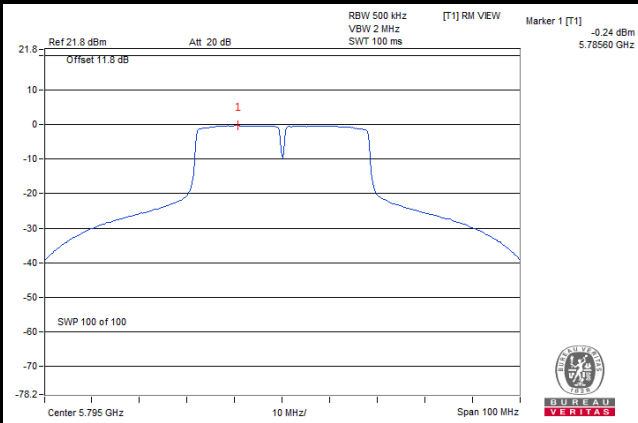

802.11ac (VHT80)

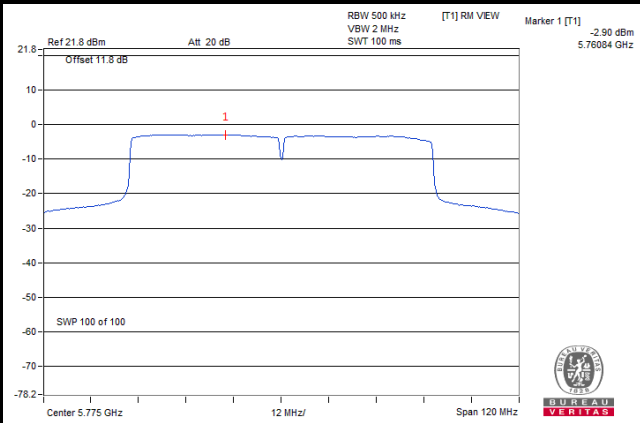

4.6 Frequency Stability

4.6.1 Limit of Frequency Stability Measurement

The frequency of the carrier signal shall be maintained within band of operation.

4.6.2 Test Setup

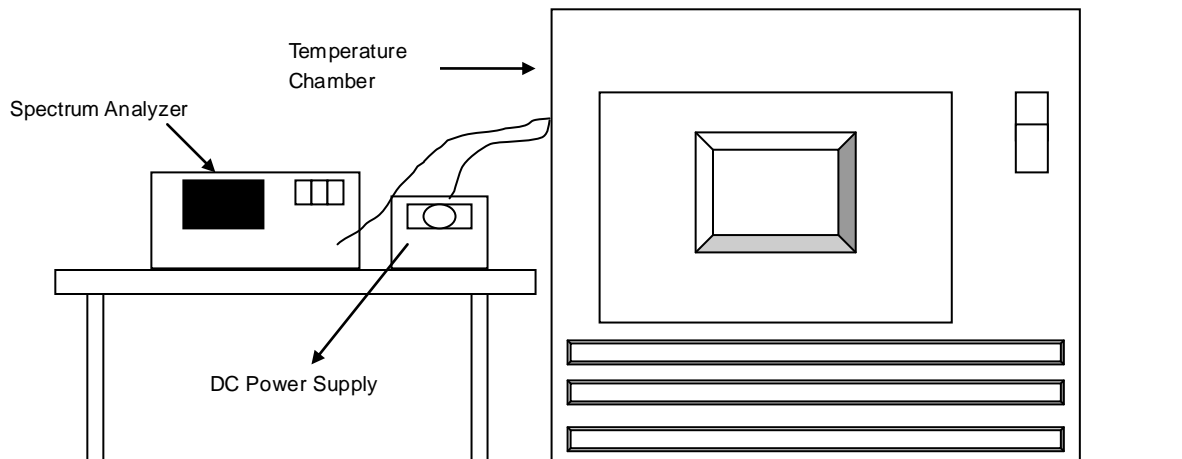

4.6.3 Test Instruments

Refer to section 4.1.3 to get information of above instrument.

4.6.4 Test Procedure

- To ensure emission at the band edge is maintained within the authorized band, those values shall be measured by radiation emissions at upper and lower frequency points, and finally compensated by frequency deviation as procedures below.
- The EUT was operated at the maximum output power, and connected to the spectrum analyzer, which is set to maximum hold function and peak detector. The peak value of the power envelope was measured and noted. The upper and lower frequency points were respectively measured relatively 10 dB lower than the measured peak value.
- The frequency deviation was calculated by adding the upper frequency point and the lower frequency point divided by two. Those detailed values of frequency deviation are provided in table below.

4.6.5 Deviation from Test Standard

No deviation.

4.6.6 EUT Operating Condition

Set the EUT transmit at un-modulation mode to test frequency stability.

4.6.7 Test Results

Frequency Stability Versus Temp.									
Operating Frequency: 5260 MHz									
Temp. (°C)	Power Supply (Vdc)	0 Minute		2 Minute		5 Minute		10 Minute	
		Measured Frequency (MHz)	Result	Measured Frequency (MHz)	Result	Measured Frequency (MHz)	Result	Measured Frequency (MHz)	Result
85	3.3	5260.0124	PASS	5260.0093	PASS	5260.0091	PASS	5260.0107	PASS
80	3.3	5259.9773	PASS	5259.9775	PASS	5259.9735	PASS	5259.9744	PASS
70	3.3	5259.9934	PASS	5259.9979	PASS	5259.9956	PASS	5259.9969	PASS
60	3.3	5260.0035	PASS	5260.0005	PASS	5260.0044	PASS	5260.0052	PASS
50	3.3	5260.0246	PASS	5260.0234	PASS	5260.0255	PASS	5260.0223	PASS
40	3.3	5259.9833	PASS	5259.9826	PASS	5259.9835	PASS	5259.9843	PASS
30	3.3	5259.983	PASS	5259.9826	PASS	5259.9864	PASS	5259.9839	PASS
20	3.3	5259.9801	PASS	5259.9816	PASS	5259.9807	PASS	5259.9804	PASS
10	3.3	5260.0231	PASS	5260.0224	PASS	5260.0226	PASS	5260.0254	PASS
0	3.3	5259.9812	PASS	5259.9843	PASS	5259.9836	PASS	5259.9858	PASS
-10	3.3	5260.0113	PASS	5260.0143	PASS	5260.0119	PASS	5260.0114	PASS
-20	3.3	5259.9947	PASS	5259.9936	PASS	5259.998	PASS	5259.9943	PASS
-30	3.3	5260.0042	PASS	5260.0045	PASS	5260.0028	PASS	5260.0037	PASS
-40	3.3	5259.983	PASS	5259.9836	PASS	5259.9858	PASS	5259.9828	PASS

Frequency Stability Versus Temp.									
Operating Frequency: 5260 MHz									
Temp. (°C)	Power Supply (Vdc)	0 Minute		2 Minute		5 Minute		10 Minute	
		Measured Frequency (MHz)	Result	Measured Frequency (MHz)	Result	Measured Frequency (MHz)	Result	Measured Frequency (MHz)	Result
20	3.795	5259.9809	PASS	5259.9823	PASS	5259.9811	PASS	5259.9809	PASS
	3.3	5259.9801	PASS	5259.9816	PASS	5259.9807	PASS	5259.9804	PASS
	2.805	5259.9796	PASS	5259.9807	PASS	5259.9807	PASS	5259.9813	PASS

4.7 6 dB Bandwidth Measurement

4.7.1 Limits of 6 dB Bandwidth Measurement

The minimum of 6 dB Bandwidth Measurement is 0.5 MHz.

4.7.2 Test Setup

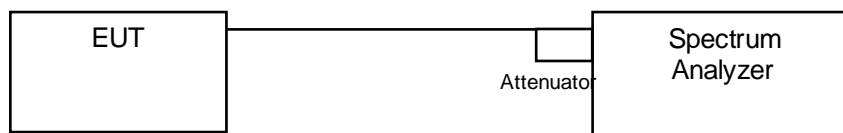

4.7.3 Test Instruments

Refer to section 4.1.3 to get information of above instrument.

4.7.4 Test Procedure

MEASUREMENT PROCEDURE REF

- Set resolution bandwidth (RBW) = 100 kHz
- Set the video bandwidth (VBW) $\geq 3 \times$ RBW, Detector = Peak.
- Trace mode = max hold.
- Sweep = auto couple.
- Measure the maximum width of the emission that is constrained by the frequencies associated with the two amplitude points (upper and lower) that are attenuated by 6 dB relative to the maximum level measured in the fundamental emission

4.7.5 Deviation from Test Standard

No deviation.

4.7.6 EUT Operating Condition

The software provided by client to enable the EUT under transmission condition continuously at lowest, middle and highest channel frequencies individually.

4.7.7 Test Results

802.11a

Channel	Frequency (MHz)	6 dB Bandwidth (MHz)	Minimum Limit (MHz)	Pass / Fail
149	5745	16.44	0.5	Pass
157	5785	16.41	0.5	Pass
165	5825	16.45	0.5	Pass

802.11n (HT20)

Channel	Frequency (MHz)	6 dB Bandwidth (MHz)		Minimum Limit (MHz)	Pass / Fail
		Chain 0	Chain 1		
149	5745	17.62	17.65	0.5	Pass
157	5785	17.61	17.61	0.5	Pass
165	5825	17.58	17.63	0.5	Pass

802.11n (HT40)

Channel	Frequency (MHz)	6 dB Bandwidth (MHz)		Minimum Limit (MHz)	Pass / Fail
		Chain 0	Chain 1		
151	5755	36.44	36.43	0.5	Pass
159	5795	36.39	36.45	0.5	Pass

802.11ac (VHT80)

Channel	Frequency (MHz)	6 dB Bandwidth (MHz)		Minimum Limit (MHz)	Pass / Fail
		Chain 0	Chain 1		
155	5775	76.15	75.85	0.5	Pass

Spectrum Plot of Worst Value

802.11a

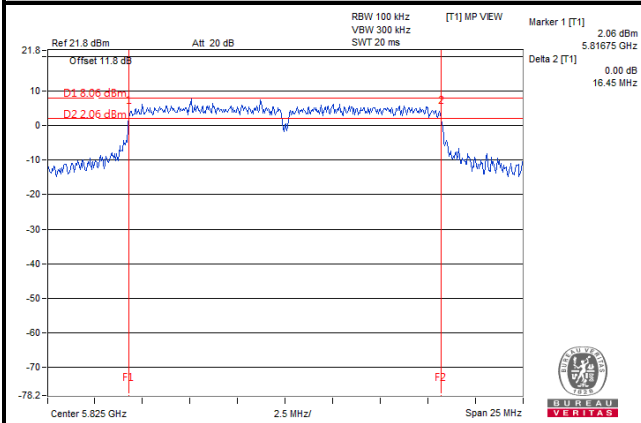

802.11n (HT20)

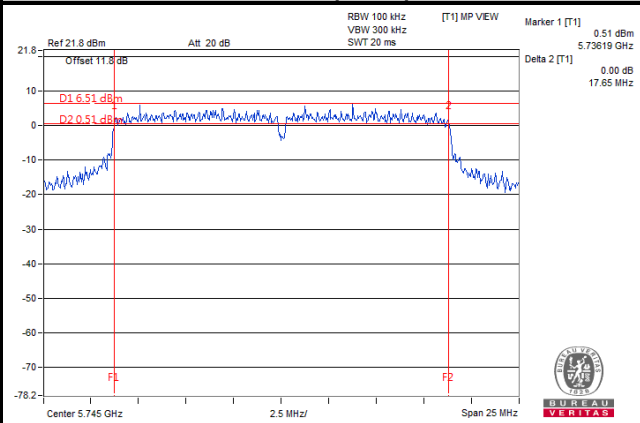

802.11n (HT40)

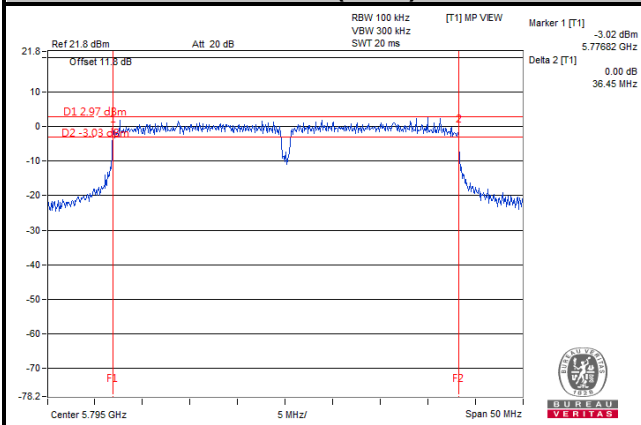

802.11ac (VHT80)

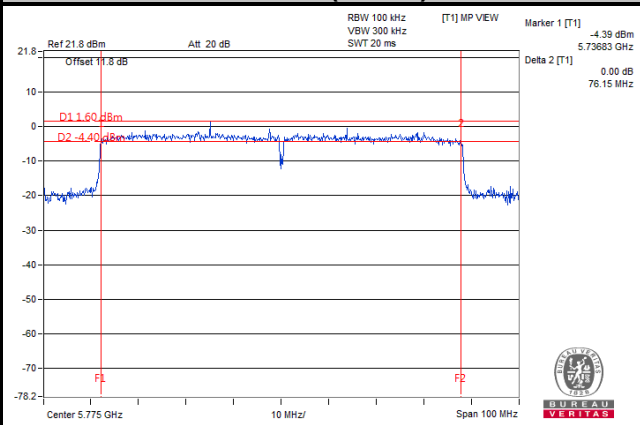

5 Pictures of Test Arrangements

Please refer to the attached file (Test Setup Photo).

Annex A- Radiated Out of Band Emisison (OOBE) Measurement (For U-NII-3 band)

802.11a

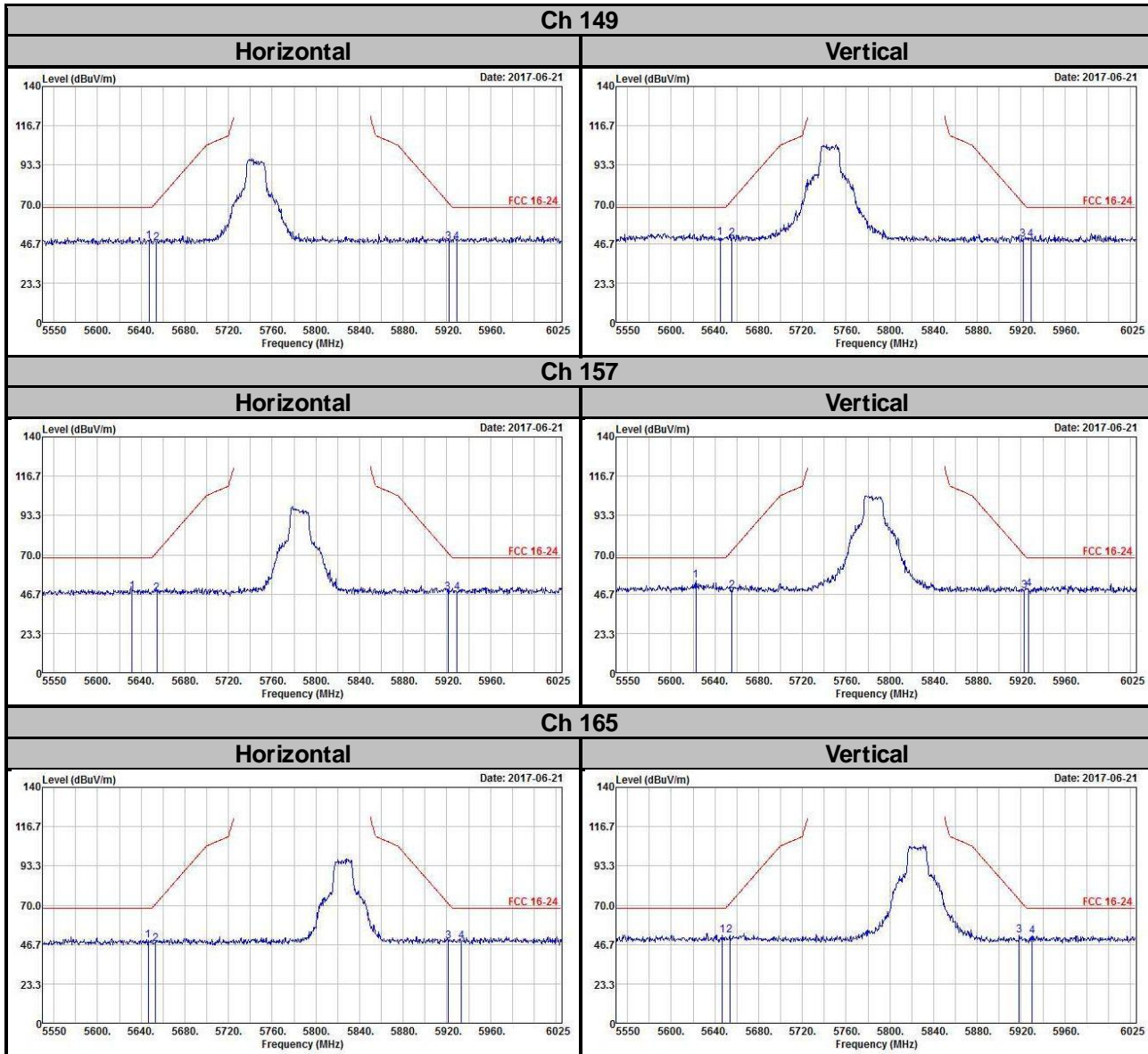

802.11n (HT20)

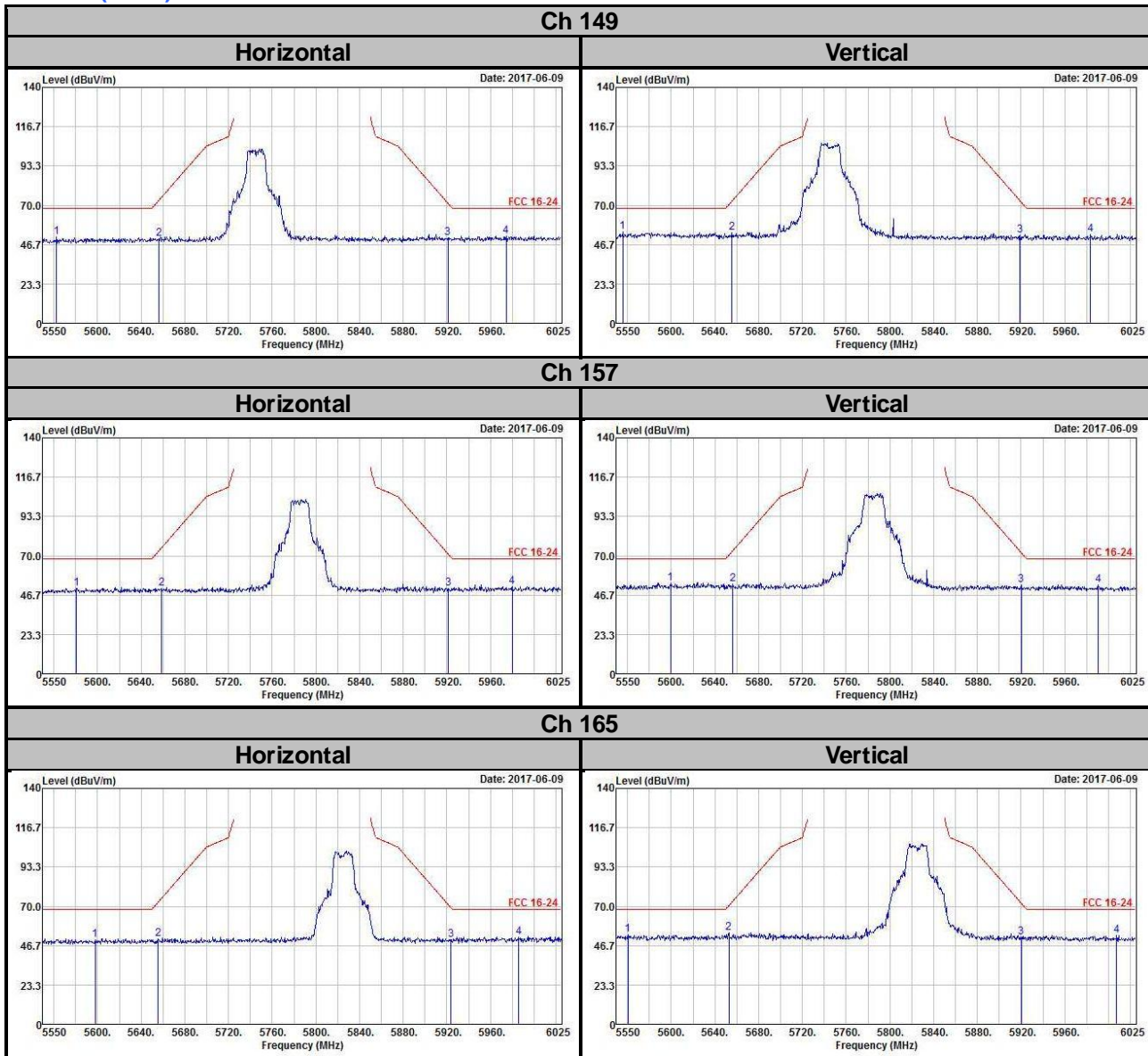

802.11n (HT40)

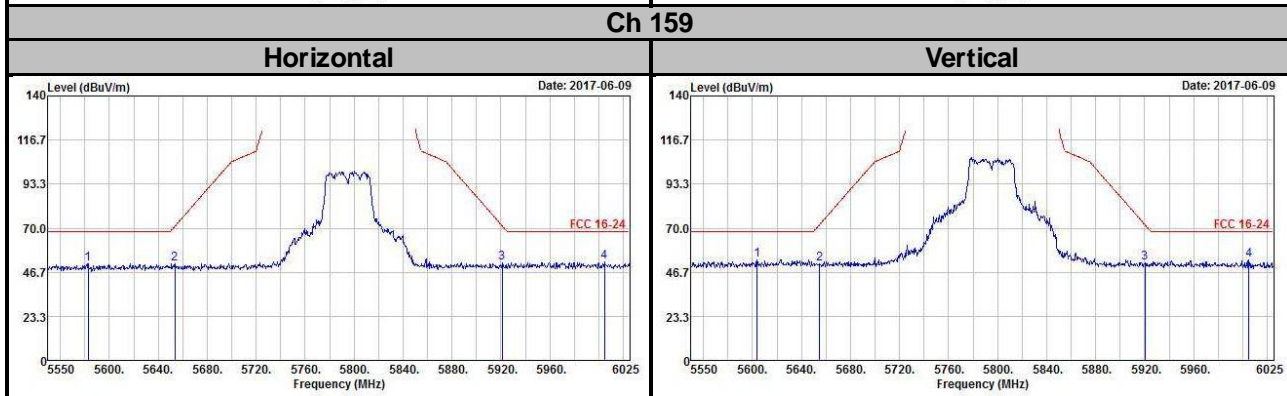
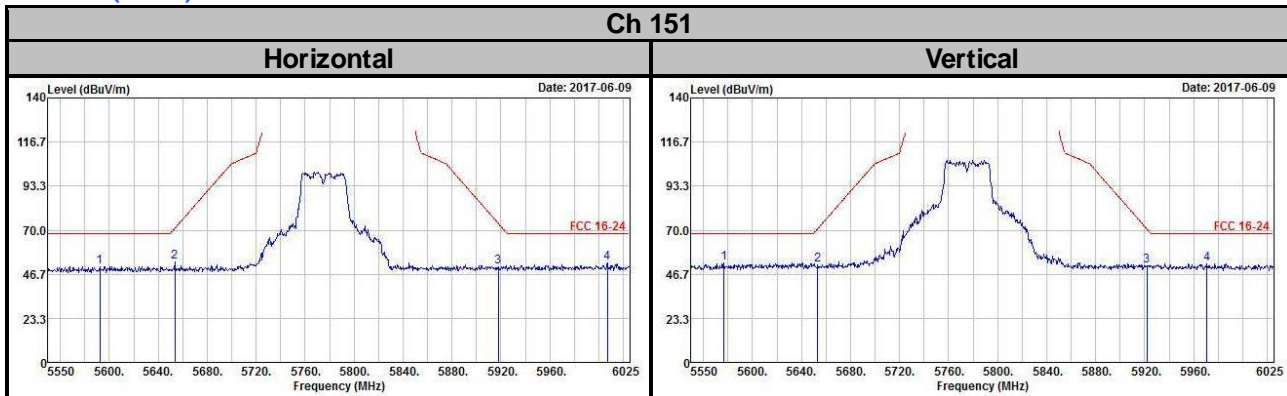

802.11ac (VHT80)

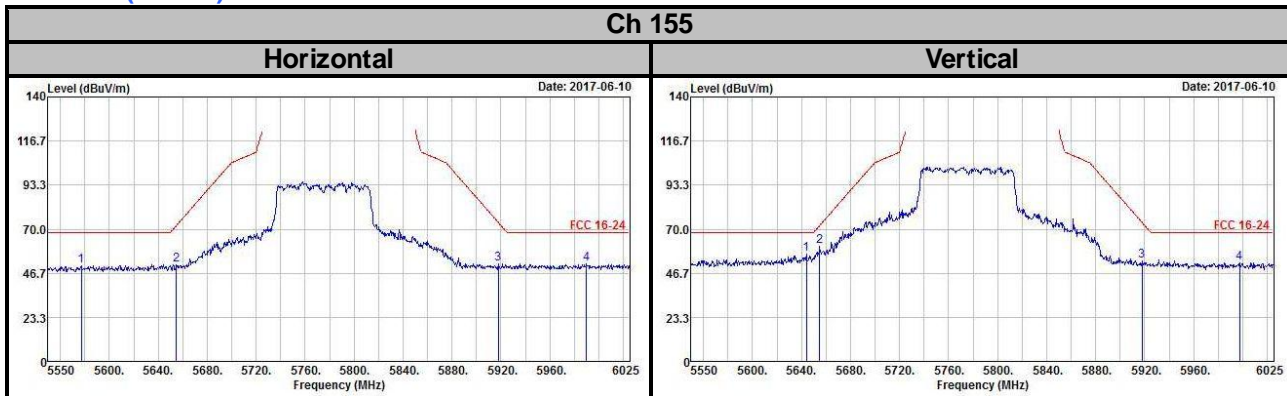

Appendix – Information on the Testing Laboratories

We, Bureau Veritas Consumer Products Services (H.K.) Ltd., Taoyuan Branch, were founded in 1988 to provide our best service in EMC, Radio, Telecom and Safety consultation. Our laboratories are FCC recognized accredited test firms and accredited according to ISO/IEC 17025.

If you have any comments, please feel free to contact us at the following:

Linko EMC/RF Lab

Tel: 886-2-26052180

Fax: 886-2-26051924

Hsin Chu EMC/RF/Telecom Lab

Tel: 886-3-6668565

Fax: 886-3-6668323

Hwa Ya EMC/RF/Safety

Tel: 886-3-3183232

Fax: 886-3-3270892

Email: service.adt@tw.bureauveritas.com

Web Site: www.bureauveritas-adt.com

The address and road map of all our labs can be found in our web site also.

--- END ---