

FCC Test Report

Report No.: RF170419C34

FCC ID: W23-JWX5556

Test Model: JWX6055, JWX6056

Received Date: Apr. 19, 2017

Test Date: Jun. 09, 2017 ~ Jul. 03, 2017

Issued Date: Jul. 17, 2017

Applicant: jjPlus CORP.

Address: 13F.-3, No.120, Qiaohe Rd., Zhonghe Dist., New Taipei City 23584, Taiwan (R.O.C.)

Issued By: Bureau Veritas Consumer Products Services (H.K.) Ltd., Taoyuan Branch

Lab Address: No. 47-2, 14th Ling, Chia Pau Vil., Lin Kou Dist., New Taipei City, Taiwan (R.O.C)

Test Location: No.19, Hwa Ya 2nd Rd., Wen Hwa Vil., Kwei Shan Dist., Taoyuan City 33383, TAIWAN (R.O.C.)



This report is for your exclusive use. Any copying or replication of this report to or for any other person or entity, or use of our name or trademark, is permitted only with our prior written permission. This report sets forth our findings solely with respect to the test samples identified herein. The results set forth in this report are not indicative or representative of the quality or characteristics of the lot from which a test sample was taken or any similar or identical product unless specifically and expressly noted. Our report includes all of the tests requested by you and the results thereof based upon the information that you provided to us. You have 60 days from date of issuance of this report to notify us of any material error or omission caused by our negligence, provided, however, that such notice shall be in writing and shall specifically address the issue you wish to raise. A failure to raise such issue within the prescribed time shall constitute your unqualified acceptance of the completeness of this report, the tests conducted and the correctness of the report contents. Unless specific mention, the uncertainty of measurement has been explicitly taken into account to declare the compliance or non-compliance to the specification.

Table of Contents

Release Control Record	4
1 Certificate of Conformity	5
2 Summary of Test Results	6
2.1 Measurement Uncertainty	6
2.2 Modification Record	6
3 General Information	7
3.1 General Description of EUT	7
3.2 Description of Test Modes	8
3.2.1 Test Mode Applicability and Tested Channel Detail	9
3.3 Duty Cycle of Test Signal	11
3.4 Description of Support Units	12
3.4.1 Configuration of System under Test	12
3.5 General Description of Applied Standards	12
4 Test Types and Results	13
4.1 Radiated Emission and Bandedge Measurement	13
4.1.1 Limits of Radiated Emission and Bandedge Measurement	13
4.1.2 Test Instruments	14
4.1.3 Test Procedures	15
4.1.4 Deviation from Test Standard	15
4.1.5 Test Set Up	16
4.1.6 EUT Operating Conditions	16
4.1.7 Test Results	17
4.2 Conducted Emission Measurement	30
4.2.1 Limits of Conducted Emission Measurement	30
4.2.2 Test Instruments	30
4.2.3 Test Procedures	31
4.2.4 Deviation from Test Standard	31
4.2.5 Test Setup	31
4.2.6 EUT Operating Conditions	31
4.2.7 Test Results	32
4.3 6 dB Bandwidth Measurement	34
4.3.1 Limits of 6 dB Bandwidth Measurement	34
4.3.2 Test Setup	34
4.3.3 Test Instruments	34
4.3.4 Test Procedure	34
4.3.5 Deviation from Test Standard	34
4.3.6 EUT Operating Conditions	34
4.3.7 Test Result	35
4.4 Occupied Bandwidth Measurement	37
4.4.1 Test Setup	37
4.4.2 Test Instruments	37
4.4.3 Test Procedure	37
4.4.4 Deviation From Test Standard	37
4.4.5 EUT Operating Conditions	37
4.4.6 Test Results	38
4.5 Conducted Output Power Measurement	40
4.5.1 Limits of Conducted Output Power Measurement	40
4.5.2 Test Setup	40
4.5.3 Test Instruments	40
4.5.4 Test Procedures	40
4.5.5 Deviation from Test Standard	40
4.5.6 EUT Operating Conditions	40
4.5.7 Test Results	41

4.6	Power Spectral Density Measurement	42
4.6.1	Limits of Power Spectral Density Measurement.....	42
4.6.2	Test Setup.....	42
4.6.3	Test Instruments	42
4.6.4	Test Procedure	42
4.6.5	Deviation from Test Standard	42
4.6.6	EUT Operating Condition	42
4.6.7	Test Results	43
4.7	Conducted Out of Band Emission Measurement	45
4.7.1	Limits of Conducted Out of Band Emission Measurement.....	45
4.7.2	Test Setup.....	45
4.7.3	Test Instruments	45
4.7.4	Test Procedure	45
4.7.5	Deviation from Test Standard	45
4.7.6	EUT Operating Condition	45
4.7.7	Test Results	46
5	Pictures of Test Arrangements.....	58
	Appendix – Information on the Testing Laboratories	59

Release Control Record

Issue No.	Description	Date Issued
RF170419C34	Original Release	Jul. 17, 2017

1 Certificate of Conformity

Product: 802.11ac/abgn 2T2R Half Mini-PCI-Express Module

Brand: jjPlus

Test Model: JWX6055, JWX6056

Sample Status: Identical Prototype

Applicant: jjPlus CORP.

Test Date: Jun. 09, 2017 ~ Jul. 03, 2017

Standards: 47 CFR FCC Part 15, Subpart C (Section 15.247)
ANSI C63.10:2013

The above equipment has been tested by **Bureau Veritas Consumer Products Services (H.K.) Ltd., Taoyuan Branch**, and found compliance with the requirement of the above standards. The test record, data evaluation & Equipment Under Test (EUT) configurations represented herein are true and accurate accounts of the measurements of the sample's EMC characteristics under the conditions specified in this report.

Prepared by :

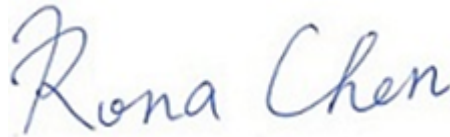

, **Date:**

Jul. 17, 2017

Rona Chen / Specialist

Approved by :

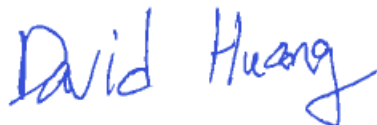

, **Date:**

Jul. 17, 2017

David Huang / Project Engineer

2 Summary of Test Results

47 CFR FCC Part 15, Subpart C (Section 15.247)			
FCC Clause	Test Item	Result	Remarks
15.207	AC Power Conducted Emission	Pass	Meet the requirement of limit. Minimum passing margin is -17.08 dB at 3.14600 MHz.
15.205 / 15.209 / 15.247(d)	Radiated Emissions and Band Edge Measurement	Pass	Meet the requirement of limit. Minimum passing margin is -1 dB at 2484 MHz.
15.247(d)	Antenna Port Emission	Pass	Meet the requirement of limit.
15.247(a)(2)	6 dB Bandwidth	Pass	Meet the requirement of limit.
15.247(b)	Conducted power	Pass	Meet the requirement of limit.
15.247(e)	Power Spectral Density	Pass	Meet the requirement of limit.
15.203	Antenna Requirement	Pass	No antenna connector is used.

2.1 Measurement Uncertainty

Where relevant, the following measurement uncertainty levels have been estimated for tests performed on the EUT:

The listed uncertainties are the worst case uncertainty for the entire range of measurement. Please note that the uncertainty values are provided for informational purposes only and are not used in determining the PASS/FAIL results.

Measurement	Frequency	Expanded Uncertainty (k=2) (\pm)
Conducted Emissions at mains ports	150 kHz ~ 30 MHz	2.44 dB
Radiated Emissions up to 1 GHz	30 MHz ~ 200 MHz	2.93 dB
	200 MHz ~ 1000 MHz	2.95 dB
Radiated Emissions above 1 GHz	1 GHz ~ 18 GHz	2.26 dB
	18 GHz ~ 40 GHz	1.94 dB

2.2 Modification Record

There were no modifications required for compliance.

3 General Information

3.1 General Description of EUT

Product	802.11ac/abgn 2T2R Half Mini-PCI-Express Module
Brand	jjPlus
Test Model	JWX6055, JWX6056
Status of EUT	Identical Prototype
Power Supply Rating	3.3 Vdc (Host equipment)
Modulation Type	CCK, DQPSK, DBPSK for DSSS 64QAM, 16QAM, QPSK, BPSK for OFDM
Modulation Technology	DSSS, OFDM
Transfer Rate	802.11b: 11.0 / 5.5 / 2.0 / 1.0 Mbps 802.11g: 54.0 / 48.0 / 36.0 / 24.0 / 18.0 / 12.0 / 9.0 / 6.0 Mbps 802.11n: up to MCS7
Operating Frequency	2412 ~ 2462 MHz
Number of Channel	11 for 802.11b, 802.11g, 802.11n (HT20) 7 for 802.11n (HT40)
Output Power	633.305 mW
Antenna Type	Dipole antenna with 2 dBi gain
Antenna Connector	N/A
Accessory Device	Refer to Note as below
Data Cable Supplied	Refer to Note as below

Note:

- The EUT incorporates a MIMO function. Physically, the EUT provides two completed transmitters and two receivers.

Modulation Mode	TX Function
802.11b	1TX
802.11g	1TX
802.11n (HT20)	2TX
802.11n (HT40)	2TX

- All models are listed as below.

Brand	Model	Difference
jjPlus	JWX6055	The difference between two model names is temperature operating range only. Other specification is the same.
	JWX6056	

* JWX6056 was chosen for the final test and only its test result was recorded in this report.

- The above EUT information is declared by manufacturer and for more detailed features description, please refer to the manufacturer's specifications or user's manual.

3.2 Description of Test Modes

11 channels are provided for 802.11b, 802.11g and 802.11n (HT20):

Channel	Frequency (MHz)	Channel	Frequency (MHz)
1	2412	7	2442
2	2417	8	2447
3	2422	9	2452
4	2427	10	2457
5	2432	11	2462
6	2437		

7 channels are provided for 802.11n (HT40):

Channel	Frequency (MHz)	Channel	Frequency (MHz)
3	2422	7	2442
4	2427	8	2447
5	2432	9	2452
6	2437		

3.2.1 Test Mode Applicability and Tested Channel Detail

EUT Configure Mode	Applicable To				Description
	RE \geq 1G	RE<1G	PLC	APCM	
A	√	-	-	√	1Tx
B	√	√	√	√	2Tx

Where **RE \geq 1G**: Radiated Emission above 1 GHz **RE<1G**: Radiated Emission below 1 GHz
PLC: Power Line Conducted Emission **APCM**: Antenna Port Conducted Measurement

NOTE: The EUT had been pre-tested on the antenna positioned of X and Z plane. The worst case was found when positioned on X-plane.

Radiated Emission Test (Above 1 GHz):

- Pre-Scan has been conducted to determine the worst-case mode from all possible combinations between available modulations, data rates and antenna ports (if EUT with antenna diversity architecture).
- Following channel(s) was (were) selected for the final test as listed below.

EUT Configure Mode	Mode	Available Channel	Tested Channel	Modulation Technology	Modulation Type	Data Rate (Mbps)
A	802.11b	1 to 11	1, 6, 11	DSSS	DBPSK	1.0
	802.11g	1 to 11	1, 6, 11	OFDM	BPSK	6.0
B	802.11n (HT20)	1 to 11	1, 6, 11	OFDM	BPSK	MCS0
	802.11n (HT40)	3 to 9	3, 6, 9	OFDM	BPSK	MCS0

Radiated Emission Test (Below 1 GHz):

- Pre-Scan has been conducted to determine the worst-case mode from all possible combinations between available modulations, data rates and antenna ports (if EUT with antenna diversity architecture).
- Following channel(s) was (were) selected for the final test as listed below.

EUT Configure Mode	Mode	Available Channel	Tested Channel	Modulation Technology	Modulation Type	Data Rate (Mbps)
B	802.11n (HT40)	3 to 9	9	OFDM	BPSK	MCS0

Power Line Conducted Emission Test:

- Pre-Scan has been conducted to determine the worst-case mode from all possible combinations between available modulations, data rates and antenna ports (if EUT with antenna diversity architecture).
- Following channel(s) was (were) selected for the final test as listed below.

EUT Configure Mode	Mode	Available Channel	Tested Channel	Modulation Technology	Modulation Type	Data Rate (Mbps)
B	802.11n (HT40)	1 to 11	9	OFDM	BPSK	MCS0

Bandedge Measurement:

- Pre-Scan has been conducted to determine the worst-case mode from all possible combinations between available modulations, data rates and antenna ports (if EUT with antenna diversity architecture).
- Following channel(s) was (were) selected for the final test as listed below.

EUT Configure Mode	Mode	Available Channel	Tested Channel	Modulation Technology	Modulation Type	Data Rate (Mbps)
A	802.11b	1 to 11	1, 11	DSSS	DBPSK	1.0
	802.11g	1 to 11	1, 11	OFDM	BPSK	6.0
B	802.11n (HT20)	1 to 11	1, 11	OFDM	BPSK	MCS0
	802.11n (HT40)	3 to 9	3, 9	OFDM	BPSK	MCS0

Antenna Port Conducted Measurement:

- This item includes all test value of each mode, but only includes spectrum plot of worst value of each mode.
- Pre-Scan has been conducted to determine the worst-case mode from all possible combinations between available modulations, data rates and antenna ports (if EUT with antenna diversity architecture).
- Following channel(s) was (were) selected for the final test as listed below.

EUT Configure Mode	Mode	Available Channel	Tested Channel	Modulation Technology	Modulation Type	Data Rate (Mbps)
A	802.11b	1 to 11	1, 6, 11	DSSS	DBPSK	1.0
	802.11g	1 to 11	1, 6, 11	OFDM	BPSK	6.0
B	802.11n (HT20)	1 to 11	1, 6, 11	OFDM	BPSK	MCS0
	802.11n (HT40)	3 to 9	3, 6, 9	OFDM	BPSK	MCS0

Test Condition:

Applicable To	Environmental Conditions	Input Power	Tested by
RE \geq 1G	25 deg. C, 65 % RH	120 Vac, 60 Hz	Toby Tian
RE<1G	25 deg. C, 65 % RH	120 Vac, 60 Hz	Toby Tian
PLC	25 deg. C, 65 % RH	120 Vac, 60 Hz	Getaz Yang
APCM	25 deg. C, 65 % RH	3.3 Vdc	Anson Lin

3.3 Duty Cycle of Test Signal

Mode A

802.11b: Duty cycle of test signal is 100 %, duty factor is not required.

802.11g: Duty cycle of test signal is 100 %, duty factor is not required.

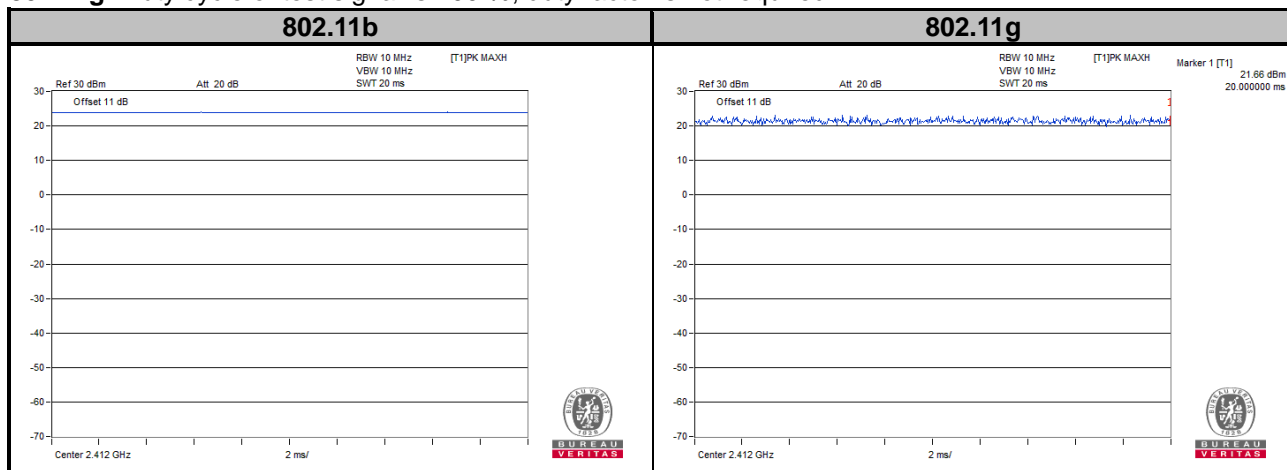

Mode B

802.11n (HT20): Duty cycle of test signal is 100 %, duty factor is not required.

802.11n (HT40): Duty cycle of test signal is 100 %, duty factor is not required.

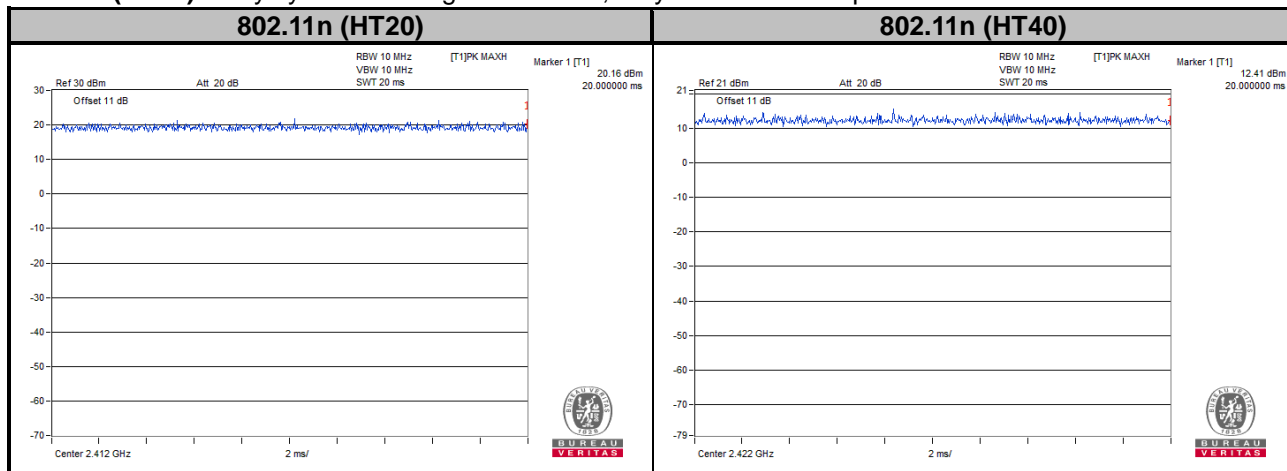

3.4 Description of Support Units

The EUT has been tested as an independent unit together with other necessary accessories or support units. The following support units or accessories were used to form a representative test configuration during the tests.

No.	Product	Brand	Model No.	Serial No.	FCC ID
1.	Notebook	DELL	E5420	33MJMQ1	N/A

No.	Signal Cable Description Of The Above Support Units
1.	N/A

Note:

1. All power cords of the above support units are non-shielded (1.8m).

3.4.1 Configuration of System under Test

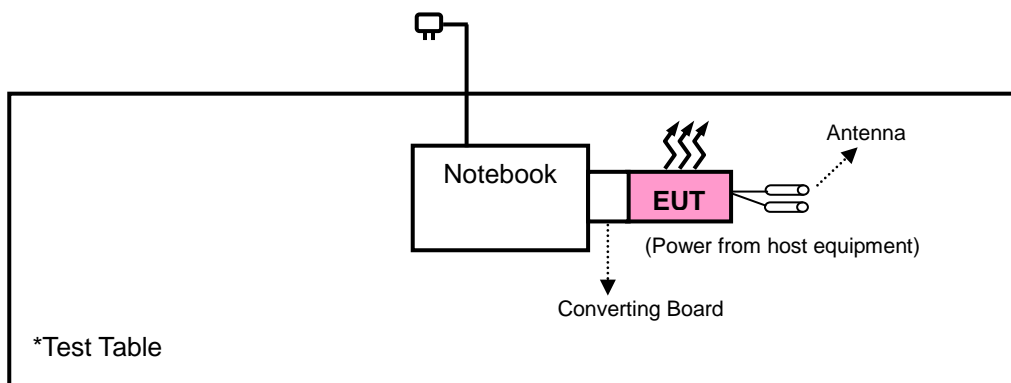

3.5 General Description of Applied Standards

The EUT is a RF Product. According to the specifications of the manufacturer, it must comply with the requirements of the following standards:

FCC Part 15, Subpart C (15.247)

558074 D01 DTS Meas Guidance v04

662911 D01 Multiple Transmitter Output v02r01

ANSI C63.10-2013

All test items have been performed and recorded as per the above standards.

NOTE: The EUT has been verified to comply with the requirements of FCC Part 15, Subpart B, Class B (DoC). The test report has been issued separately.

4 Test Types and Results

4.1 Radiated Emission and Bandedge Measurement

4.1.1 Limits of Radiated Emission and Bandedge Measurement

Radiated emissions which fall in the restricted bands must comply with the radiated emission limits specified as below table. Other emissions shall be at least 20 dB below the highest level of the desired power:

Frequencies (MHz)	Field Strength (microvolts/meter)	Measurement Distance (meters)
0.009 ~ 0.490	2400/F (kHz)	300
0.490 ~ 1.705	24000/F (kHz)	30
1.705 ~ 30.0	30	30
30 ~ 88	100	3
88 ~ 216	150	3
216 ~ 960	200	3
Above 960	500	3

NOTE:

1. The lower limit shall apply at the transition frequencies.
2. Emission level (dBuV/m) = 20 log Emission level (uV/m).
3. For frequencies above 1000 MHz, the field strength limits are based on average detector, however, the peak field strength of any emission shall not exceed the maximum permitted average limits, specified above by more than 20 dB under any condition of modulation.

4.1.2 Test Instruments

Description & Manufacturer	Model No.	Serial No.	Date of Calibration	Due Date of Calibration
Test Receiver Agilent	N9038A	MY51210203	Feb. 17, 2017	Feb. 16, 2018
Spectrum Analyzer Agilent	N9010A	MY52220314	Dec. 16, 2016	Dec. 15, 2017
Spectrum Analyzer ROHDE & SCHWARZ	FSU43	101261	Dec. 13, 2016	Dec. 12, 2017
BILOG Antenna SCHWARZBECK	VULB9168	9168-472	Dec. 26, 2016	Dec. 27, 2017
HORN Antenna SCHWARZBECK	BBHA 9120 D	9120D-969	Dec. 12, 2016	Dec. 13, 2017
HORN Antenna SCHWARZBECK	BBHA 9170	9170-480	Dec. 14, 2016	Dec. 13, 2017
Fixed Attenuator Mini-Circuits	BW-N10W5+	NA	Jul. 08, 2016	Jul. 07, 2017
Loop Antenna	EM-6879	269	Aug. 11, 2016	Aug. 10, 2017
Preamplifier EMCI	EMC 012645	980115	Oct. 21, 2016	Oct. 20, 2017
Preamplifier EMCI	EMC 184045	980116	Oct. 21, 2016	Oct. 20, 2017
Preamplifier EMCI	EMC 330H	980112	Oct. 21, 2016	Oct. 20, 2017
Power Meter Anritsu	ML2495A	1232002	Sep. 08, 2016	Sep. 07, 2017
Power Sensor Anritsu	MA2411B	1207325	Sep. 08, 2016	Sep. 07, 2017
RF signal cable HUBER+SUHNNER	SUCOFLEX 104	309219/4 2950114	Oct. 21, 2016	Oct. 20, 2017
RF signal cable HUBER+SUHNNER	SUCOFLEX 104	250130/4	Oct. 21, 2016	Oct. 20, 2017
RF Coaxial Cable Worken	8D-FB	Cable-Ch10-01	Oct. 21, 2016	Oct. 20, 2017
Software BV ADT	E3 6.120103	NA	NA	NA
Antenna Tower MF	MFA-440H	NA	NA	NA
Turn Table MF	MFT-201SS	NA	NA	NA
Antenna Tower & Turn Table Controller MF	MF-7802	NA	NA	NA

- Note: 1. The calibration interval of the above test instruments is 12 months and the calibrations are traceable to NML/ROC and NIST/USA.
2. The test was performed in HwaYa Chamber 10.
3. The horn antenna and preamplifier (model: EMC 184045) are used only for the measurement of emission frequency above 1 GHz if tested.
4. The FCC Site Registration No. is 690701.
5. The IC Site Registration No. is IC7450F-10.

4.1.3 Test Procedures

- a. The EUT was placed on the top of a rotating table 0.8 meters (for below 1 GHz) / 1.5 meters (for above 1 GHz) above the ground at 3 meter chamber room for test. The table was rotated 360 degrees to determine the position of the highest radiation.
- b. The EUT was set 3 meters away from the interference-receiving antenna, which was mounted on the top of a variable-height antenna tower.
- c. The height of antenna is varied from one meter to four meters above the ground to determine the maximum value of the field strength. Both horizontal and vertical polarizations of the antenna are set to make the measurement.
- d. For each suspected emission, the EUT was arranged to its worst case and then the antenna was tuned to heights from 1 meter to 4 meters and the rotatable table was turned from 0 degrees to 360 degrees to find the maximum reading.
- e. The test-receiver system was set to quasi-peak detect function and specified bandwidth with maximum hold mode when the test frequency is below 1 GHz.
- f. The test-receiver system was set to peak and average detected function and specified bandwidth with maximum hold mode when the test frequency is above 1 GHz. If the peak reading value also meets average limit, measurement with the average detector is unnecessary.

Note:

1. The resolution bandwidth and video bandwidth of test receiver/spectrum analyzer is 120 kHz & 360 KHz for Quasi-peak detection (QP) at frequency below 1 GHz.
2. The resolution bandwidth of test receiver/spectrum analyzer is 1 MHz and the video bandwidth is 3 MHz for Peak detection (PK) at frequency above 1 GHz.
3. The resolution bandwidth of test receiver/spectrum analyzer is 1 MHz and the video bandwidth is 1/T for Average (Duty cycle < 98 %) detection at frequency above 1 GHz.
4. The resolution bandwidth of test receiver/spectrum analyzer is 1 MHz and the video bandwidth is 10 Hz (Duty cycle \geq 98 %) for Average detection (AV) at frequency above 1 GHz.
5. All modes of operation were investigated and the worst-case emissions are reported.

4.1.4 Deviation from Test Standard

No deviation.

4.1.5 Test Set Up

<Frequency Range below 1 GHz>

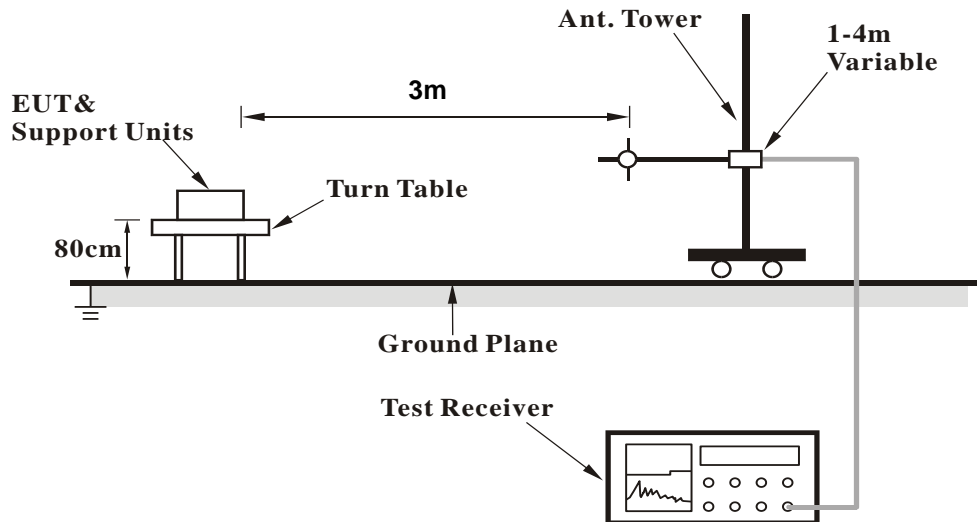

<Frequency Range above 1 GHz>

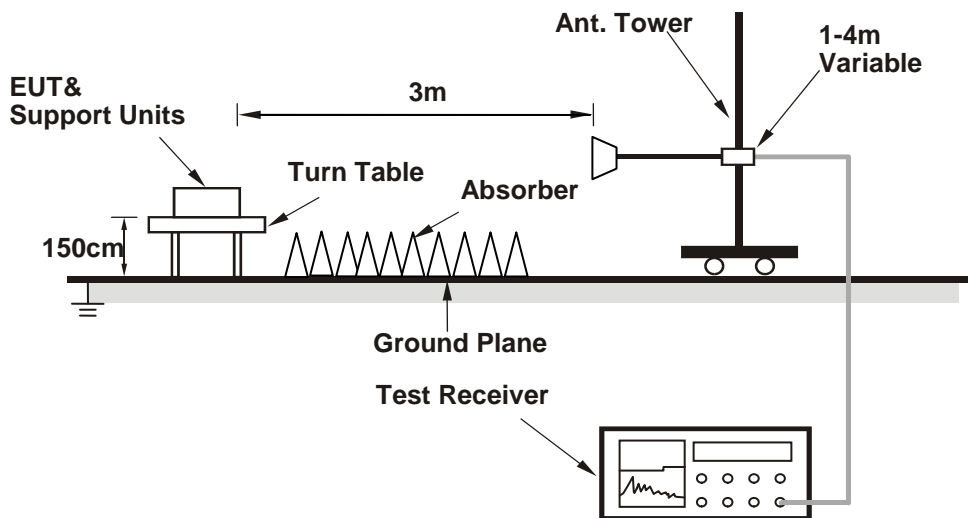

For the actual test configuration, please refer to the attached file (Test Setup Photo).

4.1.6 EUT Operating Conditions

- a. Placed the EUT on a testing table.
- b. Use the software to control the EUT under transmission condition continuously at specific channel frequency.

4.1.7 Test Results

Above 1 GHz Data :

Mode A

802.11b

EUT Test Condition		Measurement Detail	
Channel	Channel 1	Frequency Range	1 GHz ~ 25 GHz
Input Power	120 Vac, 60 Hz	Detector Function	Peak (PK) Average (AV)
Environmental Conditions	25 deg. C, 65 % RH	Tested By	Toby Tian

Antennal Polarity & Test Distance: Horizontal at 3 m										
Frequency (MHz)	Emission Level (dBuV/m)	Read Level (dBuV)	Limit (dBuV/m)	Margin (dB)	Antenna Factor (dB/m)	Cable Loss (dB)	Preamp Factor (dB)	Antenna Height (cm)	Table Angle (Degree)	Remark
2390	50.96	57.49	54	-3.04	26.91	4.08	37.52	107	167	Average
2390	58.79	65.32	74	-15.21	26.91	4.08	37.52	107	167	Peak
2412	111	117.47			26.96	4.09	37.52	107	167	Average
2412	114.6	121.07			26.96	4.09	37.52	107	167	Peak
4824	42.83	58.13	54	-11.17	30.99	6.79	53.08	138	15	Average
4824	46.07	61.37	74	-27.93	30.99	6.79	53.08	138	15	Peak

Antennal Polarity & Test Distance: Vertical at 3 m										
Frequency (MHz)	Emission Level (dBuV/m)	Read Level (dBuV)	Limit (dBuV/m)	Margin (dB)	Antenna Factor (dB/m)	Cable Loss (dB)	Preamp Factor (dB)	Antenna Height (cm)	Table Angle (Degree)	Remark
2390	48.55	55.08	54	-5.45	26.91	4.08	37.52	244	269	Average
2390	57.67	64.2	74	-16.33	26.91	4.08	37.52	244	269	Peak
2412	105.02	111.49			26.96	4.09	37.52	244	269	Average
2412	108.03	114.5			26.96	4.09	37.52	244	269	Peak
4824	37.72	53.02	54	-16.28	30.99	6.79	53.08	100	271	Average
4824	45.39	60.69	74	-28.61	30.99	6.79	53.08	100	271	Peak

Remarks:

- Emission Level = Read Level + Antenna Factor + Cable Loss - Preamp Factor
Margin value = Emission level – Limit value
- 2412 MHz: Fundamental frequency.

EUT Test Condition		Measurement Detail	
Channel	Channel 6	Frequency Range	1 GHz ~ 25 GHz
Input Power	120 Vac, 60 Hz	Detector Function	Peak (PK) Average (AV)
Environmental Conditions	25 deg. C, 65 % RH	Tested By	Toby Tian

Antennal Polarity & Test Distance: Horizontal at 3 m										
Frequency (MHz)	Emission Level (dBuV/m)	Read Level (dBuV)	Limit (dBuV/m)	Margin (dB)	Antenna Factor (dB/m)	Cable Loss (dB)	Preamp Factor (dB)	Antenna Height (cm)	Table Angle (Degree)	Remark
2366	38.05	44.67	54	-15.95	26.81	4.07	37.5	102	168	Average
2366	56.1	62.72	74	-17.9	26.81	4.07	37.5	102	168	Peak
2437	110.83	117.11			27.06	4.12	37.46	102	168	Average
2437	114.46	120.74			27.06	4.12	37.46	102	168	Peak
2488	57.69	63.65	74	-16.31	27.2	4.16	37.32	102	168	Peak
2488	38.67	44.63	74	-35.33	27.2	4.16	37.32	102	168	Peak
4874	43.46	58.6	54	-10.54	31.06	6.85	53.05	117	10	Average
4874	45.74	60.88	74	-28.26	31.06	6.85	53.05	117	10	Peak
Antennal Polarity & Test Distance: Vertical at 3 m										
Frequency (MHz)	Emission Level (dBuV/m)	Read Level (dBuV)	Limit (dBuV/m)	Margin (dB)	Antenna Factor (dB/m)	Cable Loss (dB)	Preamp Factor (dB)	Antenna Height (cm)	Table Angle (Degree)	Remark
2384	37.55	44.11	54	-16.45	26.86	4.08	37.5	239	267	Average
2384	56.67	63.23	74	-17.33	26.86	4.08	37.5	239	267	Peak
2437	104.32	110.6			27.06	4.12	37.46	239	267	Average
2437	108.4	114.68			27.06	4.12	37.46	239	267	Peak
2490	35.97	41.93	54	-18.03	27.2	4.16	37.32	239	267	Average
2490	55.66	61.62	74	-18.34	27.2	4.16	37.32	239	267	Peak
4874	36.92	52.06	54	-17.08	31.06	6.85	53.05	193	267	Average
4874	44.95	60.09	74	-29.05	31.06	6.85	53.05	193	267	Peak

Remarks:

- Emission Level = Read Level + Antenna Factor + Cable Loss - Preamp Factor
Margin value = Emission level – Limit value
- 2437 MHz: Fundamental frequency.

EUT Test Condition		Measurement Detail	
Channel	Channel 11	Frequency Range	1 GHz ~ 25 GHz
Input Power	120 Vac, 60 Hz	Detector Function	Peak (PK) Average (AV)
Environmental Conditions	25 deg. C, 65 % RH	Tested By	Toby Tian

Antennal Polarity & Test Distance: Horizontal at 3 m										
Frequency (MHz)	Emission Level (dBuV/m)	Read Level (dBuV)	Limit (dBuV/m)	Margin (dB)	Antenna Factor (dB/m)	Cable Loss (dB)	Preamp Factor (dB)	Antenna Height (cm)	Table Angle (Degree)	Remark
2462	110.96	117.12			27.1	4.13	37.39	104	168	Average
2462	114.61	120.77			27.1	4.13	37.39	104	168	Peak
2484	46.43	52.45	54	-7.57	27.15	4.15	37.32	104	168	Average
2484	57.13	63.15	74	-16.87	27.15	4.15	37.32	104	168	Peak
4924	41.98	57.01	54	-12.02	31.12	6.88	53.03	164	9	Average
4924	45.43	60.46	74	-28.57	31.12	6.88	53.03	164	9	Peak

Antennal Polarity & Test Distance: Vertical at 3 m										
Frequency (MHz)	Emission Level (dBuV/m)	Read Level (dBuV)	Limit (dBuV/m)	Margin (dB)	Antenna Factor (dB/m)	Cable Loss (dB)	Preamp Factor (dB)	Antenna Height (cm)	Table Angle (Degree)	Remark
2462	104.55	110.71			27.1	4.13	37.39	259	264	Average
2462	108.45	114.61			27.1	4.13	37.39	259	264	Peak
2498	46.21	52.1	54	-7.79	27.2	4.16	37.25	259	264	Average
2498	56.64	62.53	74	-17.36	27.2	4.16	37.25	259	264	Peak
4924	37.02	52.05	54	-16.98	31.12	6.88	53.03	100	260	Average
4924	44.71	59.74	74	-29.29	31.12	6.88	53.03	100	260	Peak

Remarks:

- Emission Level = Read Level + Antenna Factor + Cable Loss - Preamp Factor
Margin value = Emission level – Limit value
- 2462 MHz: Fundamental frequency.

802.11g

EUT Test Condition		Measurement Detail	
Channel	Channel 1	Frequency Range	1 GHz ~ 25 GHz
Input Power	120 Vac, 60 Hz	Detector Function	Peak (PK) Average (AV)
Environmental Conditions	25 deg. C, 65 % RH	Tested By	Toby Tian

Antennal Polarity & Test Distance: Horizontal at 3 m										
Frequency (MHz)	Emission Level (dBuV/m)	Read Level (dBuV)	Limit (dBuV/m)	Margin (dB)	Antenna Factor (dB/m)	Cable Loss (dB)	Preamp Factor (dB)	Antenna Height (cm)	Table Angle (Degree)	Remark
2390	52.35	58.88	54	-1.65	26.91	4.08	37.52	196	4	Average
2390	66.68	73.21	74	-7.32	26.91	4.08	37.52	196	4	Peak
2412	100.84	107.31			26.96	4.09	37.52	196	4	Average
2412	111.43	117.9			26.96	4.09	37.52	196	4	Peak
4824	34.07	49.37	54	-19.93	30.99	6.79	53.08	100	169	Average
4824	45.05	60.35	74	-28.95	30.99	6.79	53.08	100	169	Peak

Antennal Polarity & Test Distance: Vertical at 3 m										
Frequency (MHz)	Emission Level (dBuV/m)	Read Level (dBuV)	Limit (dBuV/m)	Margin (dB)	Antenna Factor (dB/m)	Cable Loss (dB)	Preamp Factor (dB)	Antenna Height (cm)	Table Angle (Degree)	Remark
2388	47.92	54.43	54	-6.08	26.91	4.08	37.5	244	271	Average
2388	61.88	68.39	74	-12.12	26.91	4.08	37.5	244	271	Peak
2412	95.18	101.65			26.96	4.09	37.52	244	271	Average
2412	105.18	111.65			26.96	4.09	37.52	244	271	Peak
4824	32.43	47.73	54	-21.57	30.99	6.79	53.08	101	188	Average
4824	44.98	60.28	74	-29.02	30.99	6.79	53.08	101	188	Peak

Remarks:

- Emission Level = Read Level + Antenna Factor + Cable Loss - Preamp Factor
Margin value = Emission level – Limit value
- 2412 MHz: Fundamental frequency.

EUT Test Condition		Measurement Detail	
Channel	Channel 6	Frequency Range	1 GHz ~ 25 GHz
Input Power	120 Vac, 60 Hz	Detector Function	Peak (PK) Average (AV)
Environmental Conditions	25 deg. C, 65 % RH	Tested By	Toby Tian

Antennal Polarity & Test Distance: Horizontal at 3 m										
Frequency (MHz)	Emission Level (dBuV/m)	Read Level (dBuV)	Limit (dBuV/m)	Margin (dB)	Antenna Factor (dB/m)	Cable Loss (dB)	Preamp Factor (dB)	Antenna Height (cm)	Table Angle (Degree)	Remark
2364	40.44	47.05	54	-13.56	26.81	4.07	37.49	192	4	Average
2364	56.96	63.57	74	-17.04	26.81	4.07	37.49	192	4	Peak
2437	103.52	109.8			27.06	4.12	37.46	192	4	Average
2437	114.07	120.35			27.06	4.12	37.46	192	4	Peak
2492	41.89	47.78	54	-12.11	27.2	4.16	37.25	192	4	Average
2492	58.9	64.79	74	-15.1	27.2	4.16	37.25	192	4	Peak
4874	33.72	48.86	54	-20.28	31.06	6.85	53.05	100	205	Average
4874	45.28	60.42	74	-28.72	31.06	6.85	53.05	100	205	Peak

Antennal Polarity & Test Distance: Vertical at 3 m										
Frequency (MHz)	Emission Level (dBuV/m)	Read Level (dBuV)	Limit (dBuV/m)	Margin (dB)	Antenna Factor (dB/m)	Cable Loss (dB)	Preamp Factor (dB)	Antenna Height (cm)	Table Angle (Degree)	Remark
2374	37.41	43.98	54	-16.59	26.86	4.07	37.5	236	270	Average
2374	58.06	64.63	74	-15.94	26.86	4.07	37.5	236	270	Peak
2437	98.54	104.82			27.06	4.12	37.46	236	270	Average
2437	108.97	115.25			27.06	4.12	37.46	236	270	Peak
2496	38.42	44.31	54	-15.58	27.2	4.16	37.25	236	270	Average
2496	57.88	63.77	74	-16.12	27.2	4.16	37.25	236	270	Peak
4874	32.26	47.4	54	-21.74	31.06	6.85	53.05	106	119	Average
4874	44.35	59.49	74	-29.65	31.06	6.85	53.05	106	119	Peak

Remarks:

- Emission Level = Read Level + Antenna Factor + Cable Loss - Preamp Factor
Margin value = Emission level – Limit value
- 2437 MHz: Fundamental frequency.

EUT Test Condition		Measurement Detail	
Channel	Channel 11	Frequency Range	1 GHz ~ 25 GHz
Input Power	120 Vac, 60 Hz	Detector Function	Peak (PK) Average (AV)
Environmental Conditions	25 deg. C, 65 % RH	Tested By	Toby Tian

Antennal Polarity & Test Distance: Horizontal at 3 m										
Frequency (MHz)	Emission Level (dBuV/m)	Read Level (dBuV)	Limit (dBuV/m)	Margin (dB)	Antenna Factor (dB/m)	Cable Loss (dB)	Preamp Factor (dB)	Antenna Height (cm)	Table Angle (Degree)	Remark
2462	101.38	107.54			27.1	4.13	37.39	188	4	Average
2462	111.88	118.04			27.1	4.13	37.39	188	4	Peak
2484	52.73	58.75	54	-1.27	27.15	4.15	37.32	188	4	Average
2484	65.52	71.54	74	-8.48	27.15	4.15	37.32	188	4	Peak
4924	33.92	48.95	54	-20.08	31.12	6.88	53.03	103	296	Average
4924	45.08	60.11	74	-28.92	31.12	6.88	53.03	103	296	Peak

Antennal Polarity & Test Distance: Vertical at 3 m										
Frequency (MHz)	Emission Level (dBuV/m)	Read Level (dBuV)	Limit (dBuV/m)	Margin (dB)	Antenna Factor (dB/m)	Cable Loss (dB)	Preamp Factor (dB)	Antenna Height (cm)	Table Angle (Degree)	Remark
2462	93.5	99.66			27.1	4.13	37.39	244	268	Average
2462	104.01	110.17			27.1	4.13	37.39	244	268	Peak
2484	43.35	49.37	54	-10.65	27.15	4.15	37.32	244	268	Average
2484	58.9	64.92	74	-15.1	27.15	4.15	37.32	244	268	Peak
4924	32.59	47.62	54	-21.41	31.12	6.88	53.03	102	174	Average
4924	44.65	59.68	74	-29.35	31.12	6.88	53.03	102	174	Peak

Remarks:

- Emission Level = Read Level + Antenna Factor + Cable Loss - Preamp Factor
Margin value = Emission level – Limit value
- 2462 MHz: Fundamental frequency.

Mode B

802.11n (HT20)

EUT Test Condition		Measurement Detail	
Channel	Channel 1	Frequency Range	1 GHz ~ 25 GHz
Input Power	120 Vac, 60 Hz	Detector Function	Peak (PK) Average (AV)
Environmental Conditions	25 deg. C, 65 % RH	Tested By	Toby Tian

Antennal Polarity & Test Distance: Horizontal at 3 m										
Frequency (MHz)	Emission Level (dBuV/m)	Read Level (dBuV)	Limit (dBuV/m)	Margin (dB)	Antenna Factor (dB/m)	Cable Loss (dB)	Preamp Factor (dB)	Antenna Height (cm)	Table Angle (Degree)	Remark
2390	52.64	59.17	54	-1.36	26.91	4.08	37.52	107	165	Average
2390	66.92	73.45	74	-7.08	26.91	4.08	37.52	107	165	Peak
2412	103.74	110.21			26.96	4.09	37.52	107	165	Average
2412	113.52	119.99			26.96	4.09	37.52	107	165	Peak
2500	38.29	44.18	54	-15.71	27.2	4.16	37.25	107	165	Average
2500	57.3	63.19	74	-16.7	27.2	4.16	37.25	107	165	Peak
4824	35.77	51.07	54	-18.23	30.99	6.79	53.08	142	11	Average
4824	44.72	60.02	74	-29.28	30.99	6.79	53.08	142	11	Peak
Antennal Polarity & Test Distance: Vertical at 3 m										
Frequency (MHz)	Emission Level (dBuV/m)	Read Level (dBuV)	Limit (dBuV/m)	Margin (dB)	Antenna Factor (dB/m)	Cable Loss (dB)	Preamp Factor (dB)	Antenna Height (cm)	Table Angle (Degree)	Remark
2390	40.58	47.11	54	-13.42	26.91	4.08	37.52	242	268	Average
2390	57.47	64	74	-16.53	26.91	4.08	37.52	242	268	Peak
2412	97.2	103.67			26.96	4.09	37.52	242	268	Average
2412	106.68	113.15			26.96	4.09	37.52	242	268	Peak
2498	35.81	41.7	54	-18.19	27.2	4.16	37.25	242	268	Average
2498	56.83	62.72	74	-17.17	27.2	4.16	37.25	242	268	Peak
4824	33.87	49.17	54	-20.13	30.99	6.79	53.08	124	124	Average
4824	44.18	59.48	74	-29.82	30.99	6.79	53.08	124	124	Peak

Remarks:

- Emission Level = Read Level + Antenna Factor + Cable Loss - Preamp Factor
Margin value = Emission level – Limit value
- 2412 MHz: Fundamental frequency.

EUT Test Condition		Measurement Detail	
Channel	Channel 6	Frequency Range	1 GHz ~ 25 GHz
Input Power	120 Vac, 60 Hz	Detector Function	Peak (PK) Average (AV)
Environmental Conditions	25 deg. C, 65 % RH	Tested By	Toby Tian

Antennal Polarity & Test Distance: Horizontal at 3 m										
Frequency (MHz)	Emission Level (dBuV/m)	Read Level (dBuV)	Limit (dBuV/m)	Margin (dB)	Antenna Factor (dB/m)	Cable Loss (dB)	Preamp Factor (dB)	Antenna Height (cm)	Table Angle (Degree)	Remark
2384	46.17	52.73	54	-7.83	26.86	4.08	37.5	107	166	Average
2384	60.45	67.01	74	-13.55	26.86	4.08	37.5	107	166	Peak
2437	108.57	114.85			27.06	4.12	37.46	107	166	Average
2437	117.95	124.23			27.06	4.12	37.46	107	166	Peak
2484	50.58	56.6	54	-3.42	27.15	4.15	37.32	107	166	Average
2484	61.72	67.74	74	-12.28	27.15	4.15	37.32	107	166	Peak
4874	43.73	58.87	54	-10.27	31.06	6.85	53.05	149	10	Average
4874	54.5	69.64	74	-19.5	31.06	6.85	53.05	149	10	Peak
Antennal Polarity & Test Distance: Vertical at 3 m										
Frequency (MHz)	Emission Level (dBuV/m)	Read Level (dBuV)	Limit (dBuV/m)	Margin (dB)	Antenna Factor (dB/m)	Cable Loss (dB)	Preamp Factor (dB)	Antenna Height (cm)	Table Angle (Degree)	Remark
2390	42.23	48.76	54	-11.77	26.91	4.08	37.52	237	264	Average
2390	57.61	64.14	74	-16.39	26.91	4.08	37.52	237	264	Peak
2437	102.2	108.48			27.06	4.12	37.46	237	264	Average
2437	111.76	118.04			27.06	4.12	37.46	237	264	Peak
2488	39.67	45.63	54	-14.33	27.2	4.16	37.32	237	264	Average
2488	57.92	63.88	74	-16.08	27.2	4.16	37.32	237	264	Peak
4874	38.24	53.38	54	-15.76	31.06	6.85	53.05	100	119	Average
4874	49.73	64.87	74	-24.27	31.06	6.85	53.05	100	119	Peak

Remarks:

- Emission Level = Read Level + Antenna Factor + Cable Loss - Preamp Factor
Margin value = Emission level – Limit value
- 2437 MHz: Fundamental frequency.

EUT Test Condition		Measurement Detail	
Channel	Channel 11	Frequency Range	1 GHz ~ 25 GHz
Input Power	120 Vac, 60 Hz	Detector Function	Peak (PK) Average (AV)
Environmental Conditions	25 deg. C, 65 % RH	Tested By	Toby Tian

Antennal Polarity & Test Distance: Horizontal at 3 m										
Frequency (MHz)	Emission Level (dBuV/m)	Read Level (dBuV)	Limit (dBuV/m)	Margin (dB)	Antenna Factor (dB/m)	Cable Loss (dB)	Preamp Factor (dB)	Antenna Height (cm)	Table Angle (Degree)	Remark
2388	39.04	45.55	54	-14.96	26.91	4.08	37.5	106	168	Average
2388	57.31	63.82	74	-16.69	26.91	4.08	37.5	106	168	Peak
2462	103.93	110.09			27.1	4.13	37.39	106	168	Average
2462	113.49	119.65			27.1	4.13	37.39	106	168	Peak
2484	52.89	58.91	54	-1.11	27.15	4.15	37.32	106	168	Average
2484	66.78	72.8	74	-7.22	27.15	4.15	37.32	106	168	Peak
4924	34.95	49.98	54	-19.05	31.12	6.88	53.03	141	11	Average
4924	44.77	59.8	74	-29.23	31.12	6.88	53.03	141	11	Peak
Antennal Polarity & Test Distance: Vertical at 3 m										
Frequency (MHz)	Emission Level (dBuV/m)	Read Level (dBuV)	Limit (dBuV/m)	Margin (dB)	Antenna Factor (dB/m)	Cable Loss (dB)	Preamp Factor (dB)	Antenna Height (cm)	Table Angle (Degree)	Remark
2368	34.96	41.58	54	-19.04	26.81	4.07	37.5	232	266	Average
2368	55.49	62.11	74	-18.51	26.81	4.07	37.5	232	266	Peak
2462	97.52	103.68			27.1	4.13	37.39	232	266	Average
2462	106.83	112.99			27.1	4.13	37.39	232	266	Peak
2484	43.39	49.41	54	-10.61	27.15	4.15	37.32	232	266	Average
2484	58.59	64.61	74	-15.41	27.15	4.15	37.32	232	266	Peak
4924	32.52	47.55	54	-21.48	31.12	6.88	53.03	100	223	Average
4924	44.01	59.04	74	-29.99	31.12	6.88	53.03	100	223	Peak

Remarks:

- Emission Level = Read Level + Antenna Factor + Cable Loss - Preamp Factor
Margin value = Emission level – Limit value
- 2462 MHz: Fundamental frequency.

802.11n (HT40)

EUT Test Condition		Measurement Detail	
Channel	Channel 3	Frequency Range	1 GHz ~ 25 GHz
Input Power	120 Vac, 60 Hz	Detector Function	Peak (PK) Average (AV)
Environmental Conditions	25 deg. C, 65 % RH	Tested By	Toby Tian

Antennal Polarity & Test Distance: Horizontal at 3 m

Frequency (MHz)	Emission Level (dBuV/m)	Read Level (dBuV)	Limit (dBuV/m)	Margin (dB)	Antenna Factor (dB/m)	Cable Loss (dB)	Preamp Factor (dB)	Antenna Height (cm)	Table Angle (Degree)	Remark
2390	52.39	58.92	54	-1.61	26.91	4.08	37.52	108	164	Average
2390	65.15	71.68	74	-8.85	26.91	4.08	37.52	108	164	Peak
2422	97.23	103.57			27.01	4.11	37.46	108	164	Average
2422	106.58	112.92			27.01	4.11	37.46	108	164	Peak
2484	38.68	44.7	54	-15.32	27.15	4.15	37.32	108	164	Average
2484	57.49	63.51	74	-16.51	27.15	4.15	37.32	108	164	Peak
4844	36	51.23	54	-18	31.01	6.82	53.06	100	128	Average
4844	44.67	59.9	74	-29.33	31.01	6.82	53.06	100	128	Peak

Antennal Polarity & Test Distance: Vertical at 3 m

Frequency (MHz)	Emission Level (dBuV/m)	Read Level (dBuV)	Limit (dBuV/m)	Margin (dB)	Antenna Factor (dB/m)	Cable Loss (dB)	Preamp Factor (dB)	Antenna Height (cm)	Table Angle (Degree)	Remark
2380	41.67	48.23	54	-12.33	26.86	4.08	37.5	241	268	Average
2380	58.86	65.42	74	-15.14	26.86	4.08	37.5	241	268	Peak
2422	91.81	98.15			27.01	4.11	37.46	241	268	Average
2422	101.13	107.47			27.01	4.11	37.46	241	268	Peak
2484	36.08	42.1	54	-17.92	27.15	4.15	37.32	241	268	Average
2484	56.24	62.26	74	-17.76	27.15	4.15	37.32	241	268	Peak
4844	35.06	50.29	54	-18.94	31.01	6.82	53.06	133	120	Average
4844	44.25	59.48	74	-29.75	31.01	6.82	53.06	133	120	Peak

Remarks:

- Emission Level = Read Level + Antenna Factor + Cable Loss - Preamp Factor
Margin value = Emission level – Limit value
- 2422 MHz: Fundamental frequency.

EUT Test Condition		Measurement Detail	
Channel	Channel 6	Frequency Range	1 GHz ~ 25 GHz
Input Power	120 Vac, 60 Hz	Detector Function	Peak (PK) Average (AV)
Environmental Conditions	25 deg. C, 65 % RH	Tested By	Toby Tian

Antennal Polarity & Test Distance: Horizontal at 3 m										
Frequency (MHz)	Emission Level (dBuV/m)	Read Level (dBuV)	Limit (dBuV/m)	Margin (dB)	Antenna Factor (dB/m)	Cable Loss (dB)	Preamp Factor (dB)	Antenna Height (cm)	Table Angle (Degree)	Remark
2390	48.65	55.18	54	-5.35	26.91	4.08	37.52	106	167	Average
2390	61.39	67.92	74	-12.61	26.91	4.08	37.52	106	167	Peak
2437	101.87	108.15			27.06	4.12	37.46	106	167	Average
2437	111.35	117.63			27.06	4.12	37.46	106	167	Peak
2484	52.94	58.96	54	-1.06	27.15	4.15	37.32	106	167	Average
2484	66.28	72.3	74	-7.72	27.15	4.15	37.32	106	167	Peak
4874	35.14	50.28	54	-18.86	31.06	6.85	53.05	100	122	Average
4874	46.62	61.76	74	-27.38	31.06	6.85	53.05	100	122	Peak

Antennal Polarity & Test Distance: Vertical at 3 m										
Frequency (MHz)	Emission Level (dBuV/m)	Read Level (dBuV)	Limit (dBuV/m)	Margin (dB)	Antenna Factor (dB/m)	Cable Loss (dB)	Preamp Factor (dB)	Antenna Height (cm)	Table Angle (Degree)	Remark
2390	42.02	48.55	54	-11.98	26.91	4.08	37.52	238	268	Average
2390	56.64	63.17	74	-17.36	26.91	4.08	37.52	238	268	Peak
2437	96.85	103.13			27.06	4.12	37.46	238	268	Average
2437	106.46	112.74			27.06	4.12	37.46	238	268	Peak
2492	41.97	47.86	54	-12.03	27.2	4.16	37.25	238	268	Average
2492	57.11	63	74	-16.89	27.2	4.16	37.25	238	268	Peak
4874	32.49	47.63	54	-21.51	31.06	6.85	53.05	100	158	Average
4874	44.06	59.2	74	-29.94	31.06	6.85	53.05	100	158	Peak

Remarks:

- Emission Level = Read Level + Antenna Factor + Cable Loss - Preamp Factor
Margin value = Emission level – Limit value
- 2437 MHz: Fundamental frequency.

EUT Test Condition		Measurement Detail	
Channel	Channel 9	Frequency Range	1 GHz ~ 25 GHz
Input Power	120 Vac, 60 Hz	Detector Function	Peak (PK) Average (AV)
Environmental Conditions	25 deg. C, 65 % RH	Tested By	Toby Tian

Antennal Polarity & Test Distance: Horizontal at 3 m										
Frequency (MHz)	Emission Level (dBuV/m)	Read Level (dBuV)	Limit (dBuV/m)	Margin (dB)	Antenna Factor (dB/m)	Cable Loss (dB)	Preamp Factor (dB)	Antenna Height (cm)	Table Angle (Degree)	Remark
2320	38.82	45.54	54	-15.18	26.72	4.03	37.47	107	169	Average
2320	56.62	63.34	74	-17.38	26.72	4.03	37.47	107	169	Peak
2452	97.3	103.5			27.06	4.13	37.39	107	169	Average
2452	106.63	112.83			27.06	4.13	37.39	107	169	Peak
2484	53	59.02	54	-1	27.15	4.15	37.32	107	169	Average
2484	67.5	73.52	74	-6.5	27.15	4.15	37.32	107	169	Peak
4904	35.27	50.32	54	-18.73	31.1	6.88	53.03	100	147	Average
4904	45.14	60.19	74	-28.86	31.1	6.88	53.03	100	147	Peak

Antennal Polarity & Test Distance: Vertical at 3 m										
Frequency (MHz)	Emission Level (dBuV/m)	Read Level (dBuV)	Limit (dBuV/m)	Margin (dB)	Antenna Factor (dB/m)	Cable Loss (dB)	Preamp Factor (dB)	Antenna Height (cm)	Table Angle (Degree)	Remark
2348	37.13	43.8	54	-16.87	26.77	4.05	37.49	240	266	Average
2348	56.43	63.1	74	-17.57	26.77	4.05	37.49	240	266	Peak
2452	92.57	98.77			27.06	4.13	37.39	240	266	Average
2452	100.79	106.99			27.06	4.13	37.39	240	266	Peak
2488	43.37	49.33	54	-10.63	27.2	4.16	37.32	240	266	Average
2488	58.83	64.79	74	-15.17	27.2	4.16	37.32	240	266	Peak
4904	34.56	49.61	54	-19.44	31.1	6.88	53.03	109	258	Average
4904	44.71	59.76	74	-29.29	31.1	6.88	53.03	109	258	Peak

Remarks:

- Emission Level = Read Level + Antenna Factor + Cable Loss - Preamp Factor
Margin value = Emission level – Limit value
- 2452 MHz: Fundamental frequency.

9 kHz ~ 30 MHz DATA:

The amplitude of spurious emissions attenuated more than 20 dB below the permissible value is not required to be report.

30 MHz ~ 1 GHz WORST-CASE DATA:

802.11n (HT40)

EUT Test Condition		Measurement Detail	
Channel	Channel 9	Frequency Range	30 MHz ~ 1 GHz
Input Power	120 Vac, 60 Hz	Detector Function	Peak (PK) Quasi-peak (QP)
Environmental Conditions	25 deg. C, 65 % RH	Tested By	Toby Tian

Antennal Polarity & Test Distance: Horizontal at 3 m										
Frequency (MHz)	Emission Level (dBuV/m)	Read Level (dBuV)	Limit (dBuV/m)	Margin (dB)	Antenna Factor (dB/m)	Cable Loss (dB)	Preamp Factor (dB)	Antenna Height (cm)	Table Angle (Degree)	Remark
99.84	36.24	58.1	43.5	-7.26	9.06	1.04	31.96	111	16	Peak
143.49	37.75	55.75	43.5	-5.75	12.47	1.16	31.63	134	24	Peak
166.77	39.57	58.16	43.5	-3.93	12.05	1.13	31.77	119	270	Peak
230.79	40.22	59.99	46	-5.78	10.66	1.42	31.85	136	142	Peak
298.69	41.18	58.46	46	-4.82	12.91	1.63	31.82	111	189	Peak
700.27	42.38	50.9	46	-3.62	20.82	2.45	31.79	103	20	Peak

Antennal Polarity & Test Distance: Vertical at 3 m										
Frequency (MHz)	Emission Level (dBuV/m)	Read Level (dBuV)	Limit (dBuV/m)	Margin (dB)	Antenna Factor (dB/m)	Cable Loss (dB)	Preamp Factor (dB)	Antenna Height (cm)	Table Angle (Degree)	Remark
99.84	39.62	61.48	43.5	-3.88	9.06	1.04	31.96	138	152	Peak
166.77	38.33	56.92	43.5	-5.17	12.05	1.13	31.77	101	296	Peak
222.06	35.27	55.33	46	-10.73	10.3	1.38	31.74	111	81	Peak
559.62	30.4	41.59	46	-15.6	18.68	2.19	32.06	116	285	Peak
575.14	26.99	37.84	46	-19.01	19.03	2.22	32.1	134	327	Peak
699.3	41.36	49.89	46	-4.64	20.81	2.45	31.79	105	280	Peak

Remarks:

- Emission Level = Read Level + Antenna Factor + Cable Loss - Preamp Factor
Margin value = Emission level – Limit value

4.2 Conducted Emission Measurement

4.2.1 Limits of Conducted Emission Measurement

Frequency (MHz)	Conducted Limit (dBuV)	
	Quasi-peak	Average
0.15 - 0.5	66 - 56	56 - 46
0.50 - 5.0	56	46
5.0 - 30.0	60	50

Note: 1. The lower limit shall apply at the transition frequencies.

2. The limit decreases in line with the logarithm of the frequency in the range of 0.15 to 0.50 MHz.

4.2.2 Test Instruments

Description & Manufacturer	Model No.	Serial No.	Date of Calibration	Due Date of Calibration
Test Receiver ROHDE & SCHWARZ	ESCI	100613	Nov. 21, 2016	Nov. 20, 2017
RF signal cable Woken	5D-FB	Cable-cond1-01	Dec. 22, 2016	Dec. 21, 2017
LISN ROHDE & SCHWARZ (EUT)	ESH3-Z5	835239/001	Mar. 10, 2017	Mar. 09, 2018
LISN ROHDE & SCHWARZ (Peripheral)	ESH3-Z5	100311	Jul. 28, 2016	Jul. 27, 2017
Software ADT	BV ADT_Cond_ V7.3.7.3	NA	NA	NA

Note: 1. The calibration interval of the above test instruments is 12 months and the calibrations are traceable to NML/ROC and NIST/USA.

2. The test was performed in HwaYa Shielded Room 1.

3. The VCCI Site Registration No. is C-2040.

4.2.3 Test Procedures

- The EUT was placed 0.4 meters from the conducting wall of the shielded room with EUT being connected to the power mains through a line impedance stabilization network (LISN). Other support units were connected to the power mains through another LISN. The two LISNs provide 50 ohm/50 uH of coupling impedance for the measuring instrument.
- Both lines of the power mains connected to the EUT were checked for maximum conducted interference.
- The frequency range from 150 kHz to 30 MHz was searched. Emission levels under (Limit – 20 dB) was not recorded.

NOTE: All modes of operation were investigated and the worst-case emissions are reported.

4.2.4 Deviation from Test Standard

No deviation.

4.2.5 Test Setup

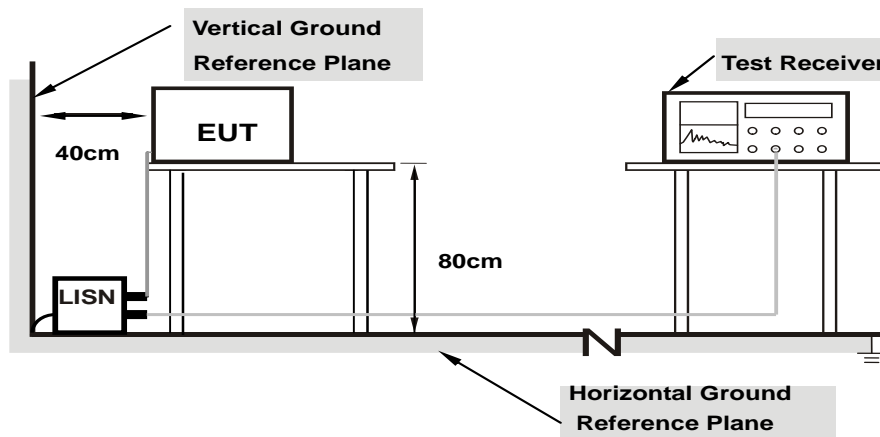

Note: 1.Support units were connected to second LISN.

For the actual test configuration, please refer to the attached file (Test Setup Photo).

4.2.6 EUT Operating Conditions

- Placed the EUT on a testing table.
- Use the software to control the EUT under transmission condition continuously at specific channel frequency.

4.2.7 Test Results

Frequency Range	150kHz ~ 30MHz	Detector Function & Resolution Bandwidth	Quasi-Peak (QP) / Average (AV), 9kHz
Input Power	120Vac, 60Hz	Environmental Conditions	25°C, 65%RH
Tested by	Getaz Yang	Test Date	2017/6/21

Phase Of Power : Line (L)										
No	Frequency (MHz)	Correction Factor (dB)	Reading Value (dBuV)		Emission Level (dBuV)		Limit (dBuV)		Margin (dB)	
			Q.P.	AV.	Q.P.	AV.	Q.P.	AV.	Q.P.	AV.
1	0.16535	10.35	31.17	7.87	41.52	18.22	65.19	55.19	-23.67	-36.97
2	0.18617	10.36	30.86	16.80	41.22	27.16	64.21	54.21	-22.99	-27.05
3	0.73400	10.40	22.93	10.10	33.33	20.50	56.00	46.00	-22.67	-25.50
4	1.92200	10.46	24.02	15.27	34.48	25.73	56.00	46.00	-21.52	-20.27
5	3.14600	10.52	26.35	18.40	36.87	28.92	56.00	46.00	-19.13	-17.08
6	7.49000	10.72	22.06	15.43	32.78	26.15	60.00	50.00	-27.22	-23.85

Remarks:

1. Q.P. and AV. are abbreviations of quasi-peak and average individually.
2. The emission levels of other frequencies were very low against the limit.
3. Margin value = Emission level – Limit value
4. Correction factor = Insertion loss + Cable loss
5. Emission Level = Correction Factor + Reading Value

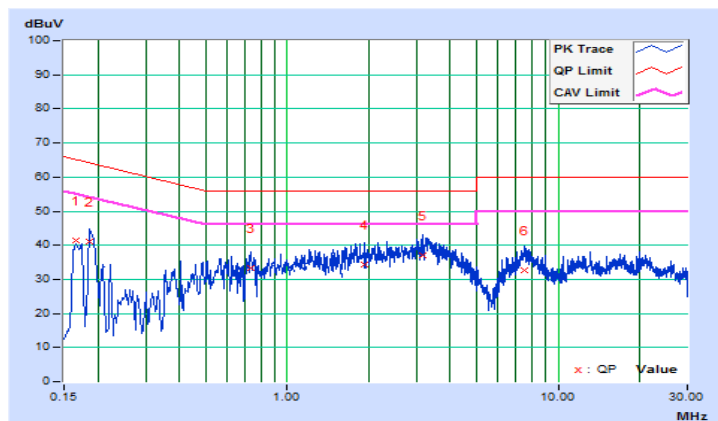

Frequency Range	150kHz ~ 30MHz	Detector Function & Resolution Bandwidth	Quasi-Peak (QP) / Average (AV), 9kHz
Input Power	120Vac, 60Hz	Environmental Conditions	25°C, 65%RH
Tested by	Getaz Yang	Test Date	2017/6/21

Phase Of Power : Neutral (N)										
No	Frequency (MHz)	Correction Factor (dB)	Reading Value (dBuV)		Emission Level (dBuV)		Limit (dBuV)		Margin (dB)	
			Q.P.	AV.	Q.P.	AV.	Q.P.	AV.	Q.P.	AV.
1	0.15400	10.11	34.98	12.66	45.09	22.77	65.78	55.78	-20.69	-33.01
2	0.27000	10.15	23.72	4.21	33.87	14.36	61.12	51.12	-27.25	-36.76
3	0.40605	10.16	21.90	5.89	32.06	16.05	57.73	47.73	-25.67	-31.68
4	0.90600	10.17	24.07	11.75	34.24	21.92	56.00	46.00	-21.76	-24.08
5	1.61000	10.21	24.25	14.84	34.46	25.05	56.00	46.00	-21.54	-20.95
6	2.92600	10.28	26.04	18.30	36.32	28.58	56.00	46.00	-19.68	-17.42

Remarks:

1. Q.P. and AV. are abbreviations of quasi-peak and average individually.
2. The emission levels of other frequencies were very low against the limit.
3. Margin value = Emission level – Limit value
4. Correction factor = Insertion loss + Cable loss
5. Emission Level = Correction Factor + Reading Value

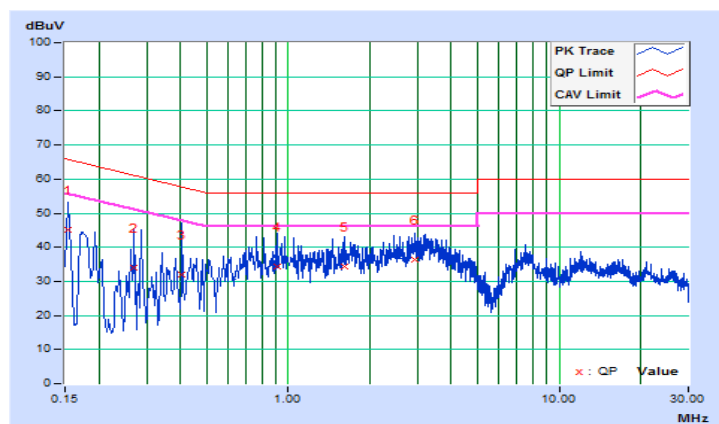

4.3 6 dB Bandwidth Measurement

4.3.1 Limits of 6 dB Bandwidth Measurement

The minimum of 6 dB Bandwidth Measurement is 0.5 MHz.

4.3.2 Test Setup

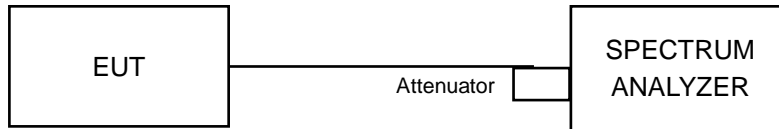

4.3.3 Test Instruments

Refer to section 4.1.2 to get information of above instrument.

4.3.4 Test Procedure

- Set resolution bandwidth (RBW) = 100 kHz
- Set the video bandwidth (VBW) $\geq 3 \times$ RBW, Detector = Peak.
- Trace mode = max hold.
- Sweep = auto couple.
- Measure the maximum width of the emission that is constrained by the frequencies associated with the two amplitude points (upper and lower) that are attenuated by 6 dB relative to the maximum level measured in the fundamental emission

4.3.5 Deviation from Test Standard

No deviation.

4.3.6 EUT Operating Conditions

The software provided by client to enable the EUT under transmission condition continuously at lowest, middle and highest channel frequencies individually.

4.3.7 Test Result

Mode A
802.11b

Channel	Frequency (MHz)	6 dB Bandwidth (MHz)	Minimum Limit (MHz)	Pass / Fail
1	2412	7.11	0.5	Pass
6	2437	7.08	0.5	Pass
11	2462	7.10	0.5	Pass

802.11g

Channel	Frequency (MHz)	6 dB Bandwidth (MHz)	Minimum Limit (MHz)	Pass / Fail
1	2412	16.35	0.5	Pass
6	2437	16.37	0.5	Pass
11	2462	16.36	0.5	Pass

Mode B
802.11n (HT20)

Channel	Frequency (MHz)	6 dB Bandwidth (MHz)		Minimum Limit (MHz)	Pass / Fail
		Chain 0	Chain 1		
1	2412	17.35	17.57	0.5	Pass
6	2437	17.60	17.60	0.5	Pass
11	2462	17.55	17.64	0.5	Pass

802.11n (HT40)

Channel	Frequency (MHz)	6 dB Bandwidth (MHz)		Minimum Limit (MHz)	Pass / Fail
		Chain 0	Chain 1		
3	2422	35.51	36.44	0.5	Pass
6	2437	35.87	36.34	0.5	Pass
9	2452	36.37	36.32	0.5	Pass

Spectrum Plot of Worst Value

802.11b

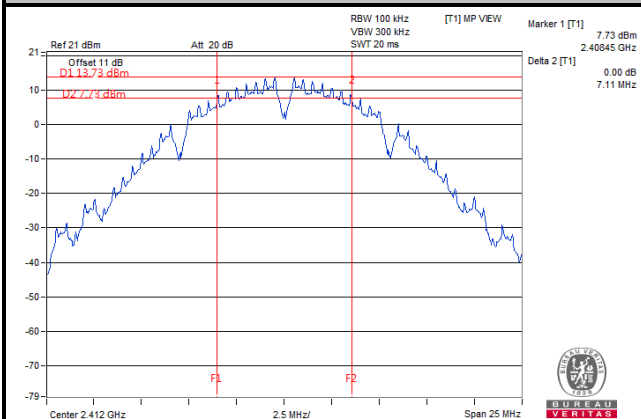

802.11g

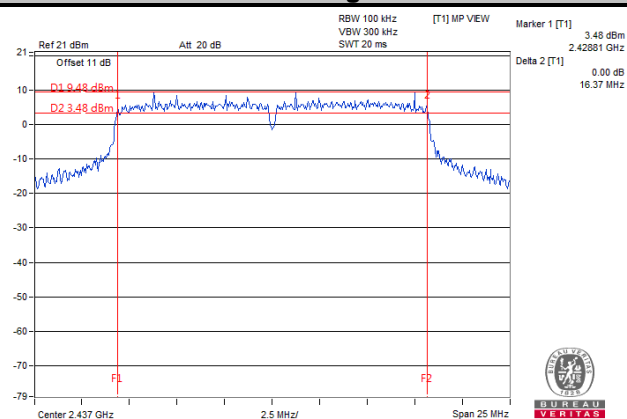

802.11n (HT20)

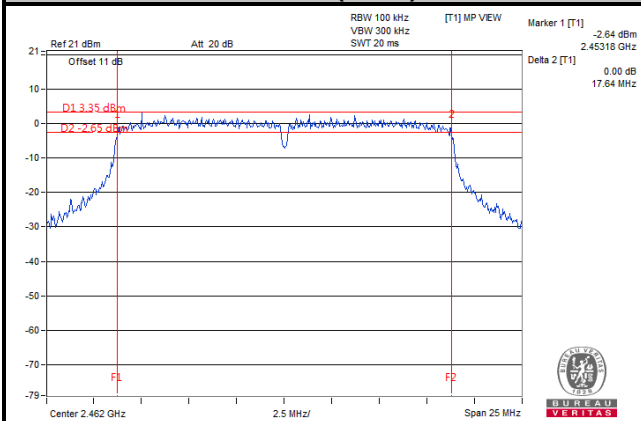

802.11n (HT40)

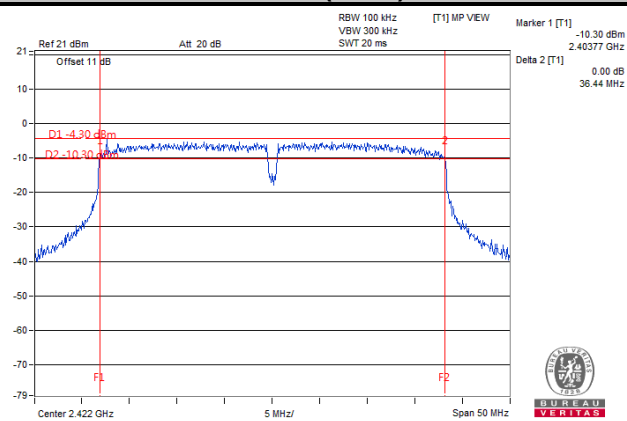

4.4 Occupied Bandwidth Measurement

4.4.1 Test Setup

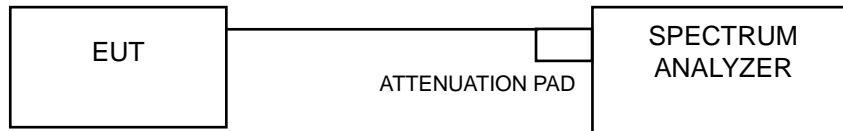

4.4.2 Test Instruments

Refer to section 4.1.2 to get information of above instrument.

4.4.3 Test Procedure

The transmitter output was connected to the spectrum analyzer through an attenuator. The bandwidth of the fundamental frequency was measured by spectrum analyzer with resolution bandwidth in the range of 1 % to 5 % of the anticipated emission bandwidth, and a video bandwidth at least 3x the resolution bandwidth and set the detector to PEAK. The width of a frequency band such that, below the lower and above the upper frequency limits, the mean powers emitted are each equal to a specified percentage 0.5 % of the total mean power of a given emission.

4.4.4 Deviation From Test Standard

No deviation.

4.4.5 EUT Operating Conditions

The software provided by client to enable the EUT under transmission condition continuously at lowest, middle and highest channel frequencies individually.

4.4.6 Test Results

Mode A

802.11b

Channel	Frequency (MHz)	Occupied Bandwidth (MHz)	Pass / Fail
1	2412	12.40	Pass
6	2437	12.35	Pass
11	2462	12.20	Pass

802.11g

Channel	Frequency (MHz)	Occupied Bandwidth (MHz)	Pass / Fail
1	2412	16.73	Pass
6	2437	17.05	Pass
11	2462	16.70	Pass

Mode B

802.11n (HT20)

Channel	Frequency (MHz)	Occupied Bandwidth (MHz)		Pass / Fail
		Chain 0	Chain 1	
1	2412	17.83	17.88	Pass
6	2437	18.35	18.35	Pass
11	2462	17.83	17.80	Pass

802.11n (HT40)

Channel	Frequency (MHz)	Occupied Bandwidth (MHz)		Pass / Fail
		Chain 0	Chain 1	
3	2422	36.69	36.53	Pass
6	2437	36.50	36.66	Pass
9	2452	36.66	36.83	Pass

Spectrum Plot of Worst Value

802.11b

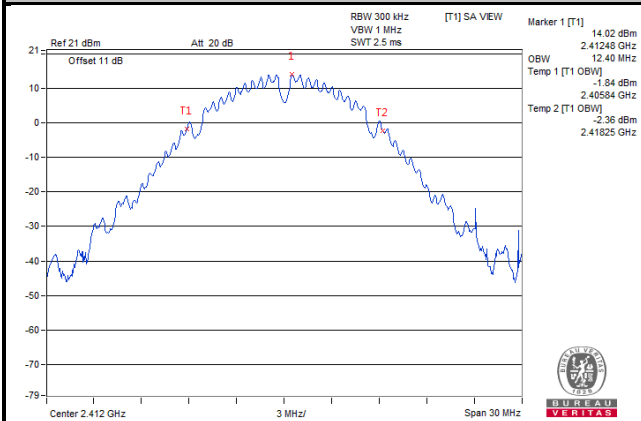

802.11g

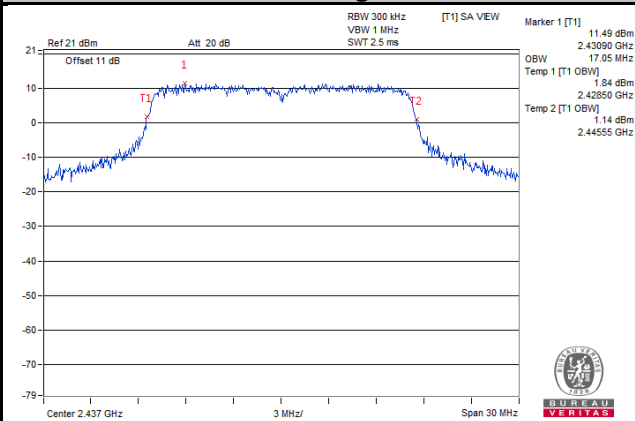

802.11n (HT20)

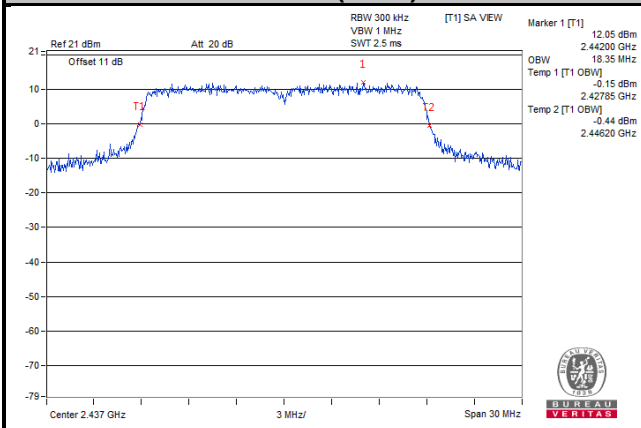

802.11n (HT40)

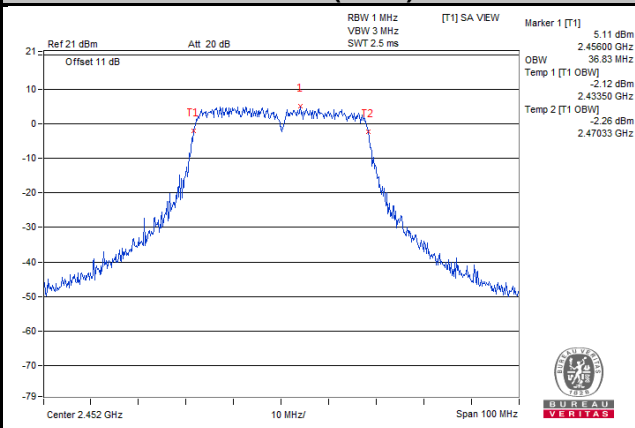

4.5 Conducted Output Power Measurement

4.5.1 Limits of Conducted Output Power Measurement

For systems using digital modulation in the 2400–2483.5 MHz bands: 1 Watt (30 dBm)

Per KDB 662911 D01 Multiple Transmitter Output Method of conducted output power measurement on IEEE 802.11 devices,

Array Gain = 0 dB (i.e., no array gain) for $NANT \leq 4$;

Array Gain = 0 dB (i.e., no array gain) for channel widths ≥ 40 MHz for any NANT;

Array Gain = $5 \log(NANT/NSS)$ dB or 3 dB, whichever is less for 20 MHz channel widths with $NANT \geq 5$.

For power measurements on all other devices: Array Gain = $10 \log(NANT/NSS)$ dB.

4.5.2 Test Setup

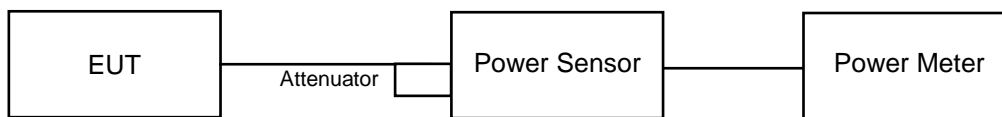

4.5.3 Test Instruments

Refer to section 4.1.2 to get information of above instrument.

4.5.4 Test Procedures

A peak power sensor was used on the output port of the EUT. A power meter was used to read the response of the peak power sensor. Record the power level.

4.5.5 Deviation from Test Standard

No deviation.

4.5.6 EUT Operating Conditions

The software provided by client to enable the EUT under transmission condition continuously at lowest, middle and highest channel frequencies individually.

4.5.7 Test Results

Mode A
802.11b

Channel	Frequency (MHz)	Peak Power (mW)	Peak Power (dBm)	Limit (dBm)	Pass / Fail
1	2412	254.683	24.06	30	Pass
6	2437	234.423	23.70	30	Pass
11	2462	232.809	23.67	30	Pass

802.11g

Channel	Frequency (MHz)	Peak Power (mW)	Peak Power (dBm)	Limit (dBm)	Pass / Fail
1	2412	207.97	23.18	30	Pass
6	2437	251.189	24.00	30	Pass
11	2462	211.836	23.26	30	Pass

Mode B
802.11n (HT20)

Channel	Frequency (MHz)	Peak Power (dBm)		Total Power (mW)	Total Power (dBm)	Limit (dBm)	Pass / Fail
		Chain 0	Chain 1				
1	2412	22.12	21.69	310.501	24.92	30	Pass
6	2437	24.92	25.09	633.305	28.02	30	Pass
11	2462	21.42	21.29	273.262	24.37	30	Pass

802.11n (HT40)

Channel	Frequency (MHz)	Peak Power (dBm)		Total Power (mW)	Total Power (dBm)	Limit (dBm)	Pass / Fail
		Chain 0	Chain 1				
3	2422	18.55	18.23	138.141	21.40	30	Pass
6	2437	21.81	21.58	295.585	24.71	30	Pass
9	2452	18.13	17.77	124.854	20.96	30	Pass

4.6 Power Spectral Density Measurement

4.6.1 Limits of Power Spectral Density Measurement

The Maximum of Power Spectral Density Measurement is 8 dBm.

4.6.2 Test Setup

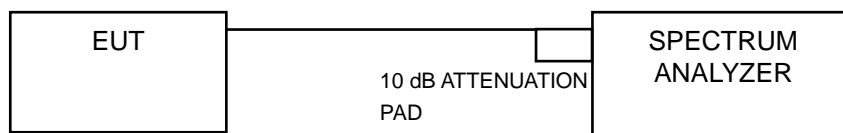

4.6.3 Test Instruments

Refer to section 4.1.2 to get information of above instrument.

4.6.4 Test Procedure

- a. Set analyzer center frequency to DTS channel center frequency.
- b. Set the span to 1.5 times the DTS bandwidth.
- c. Set the RBW to: $3 \text{ kHz} \leq \text{RBW} \leq 100 \text{ kHz}$.
- d. Set the VBW $\geq 3 \times \text{RBW}$.
- e. Detector = peak.
- f. Sweep time = auto couple.
- g. Trace mode = max hold.
- h. Allow trace to fully stabilize.
- i. Use the peak marker function to determine the maximum amplitude level within the RBW.

4.6.5 Deviation from Test Standard

No deviation.

4.6.6 EUT Operating Condition

The software provided by client to enable the EUT under transmission condition continuously at lowest, middle and highest channel frequencies individually.

4.6.7 Test Results

Mode A

802.11b

Channel	Frequency (MHz)	PSD (dBm/3 kHz)	Limit (dBm/3 kHz)	Pass / Fail
1	2412	-1.13	8	Pass
6	2437	-1.33	8	Pass
11	2462	-1.49	8	Pass

802.11g

Channel	Frequency (MHz)	PSD (dBm/3 kHz)	Limit (dBm/3 kHz)	Pass / Fail
1	2412	-7.64	8	Pass
6	2437	-4.36	8	Pass
11	2462	-7.38	8	Pass

Mode B

802.11n (HT20)

TX Chain	Channel	Freq. (MHz)	PSD (dBm/3 kHz)	10 log (N=2) dB	Total PSD (dBm/3 kHz)	Limit (dBm/3 kHz)	Pass / Fail
0	1	2412	-9.05	3.01	-6.04	8	Pass
	6	2437	-4.50	3.01	-1.49	8	Pass
	11	2462	-9.65	3.01	-6.64	8	Pass
1	1	2412	-9.52	3.01	-6.51	8	Pass
	6	2437	-4.60	3.01	-1.59	8	Pass
	11	2462	-9.86	3.01	-6.85	8	Pass

NOTE: Directional gain = 2 dBi + 10log(2) = 5.01 dBi > 6 dBi, so the limit no need to reduced.

802.11n (HT40)

TX Chain	Channel	Freq. (MHz)	PSD (dBm/3 kHz)	10 log (N=2) dB	Total PSD (dBm/3 kHz)	Limit (dBm/3 kHz)	Pass / Fail
0	3	2422	-15.06	3.01	-12.05	8	Pass
	6	2437	-11.84	3.01	-8.83	8	Pass
	9	2452	-15.60	3.01	-12.59	8	Pass
1	3	2422	-15.38	3.01	-12.37	8	Pass
	6	2437	-12.18	3.01	-9.17	8	Pass
	9	2452	-15.82	3.01	-12.81	8	Pass

NOTE: Directional gain = 2 dBi + 10log(2) = 5.01 dBi > 6 dBi, so the limit no need to reduced.

Spectrum Plot of Worst Value

802.11b

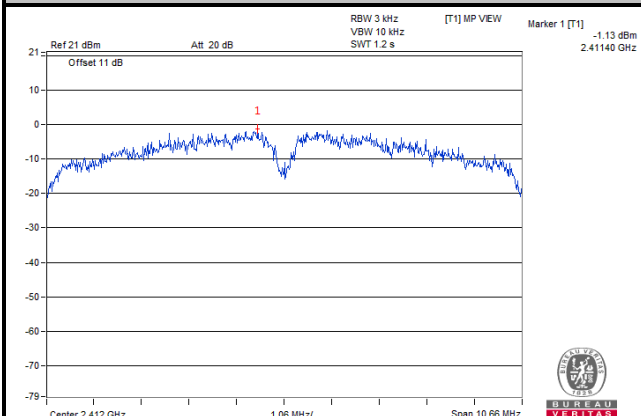

802.11g

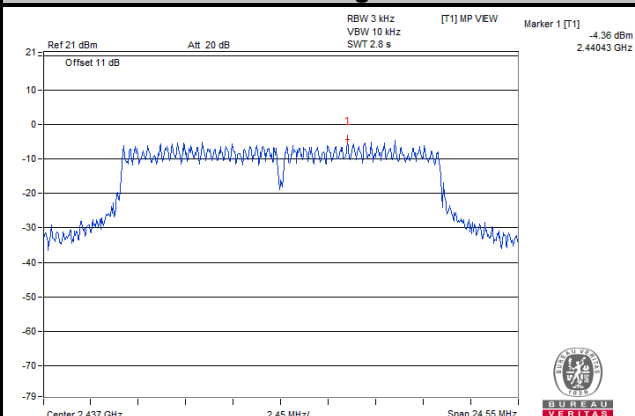

802.11n (HT20)

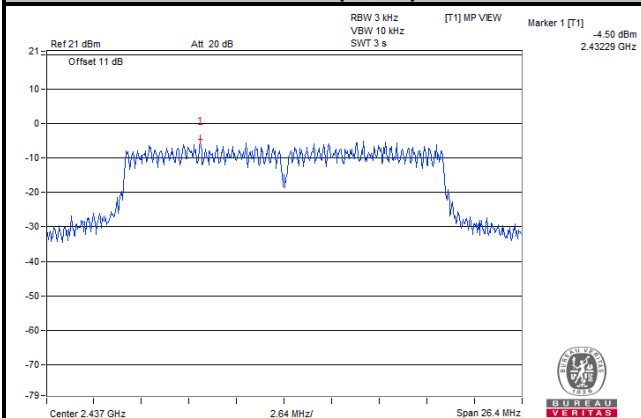

802.11n (HT40)

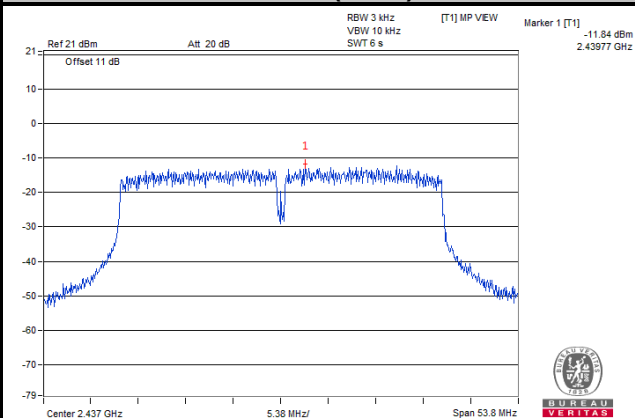

4.7 Conducted Out of Band Emission Measurement

4.7.1 Limits of Conducted Out of Band Emission Measurement

Below 20 dB of the highest emission level of operating band (in 100 kHz Resolution Bandwidth).

4.7.2 Test Setup

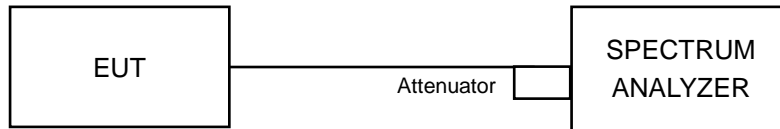

4.7.3 Test Instruments

Refer to section 4.1.2 to get information of above instrument.

4.7.4 Test Procedure

MEASUREMENT PROCEDURE REF

1. Set the RBW = 100 kHz.
2. Set the VBW \geq 300 kHz.
3. Detector = peak.
4. Sweep time = auto couple.
5. Trace mode = max hold.
6. Allow trace to fully stabilize.
7. Use the peak marker function to determine the maximum power level in any 100 kHz band segment within the fundamental EBW.

MEASUREMENT PROCEDURE OOB

1. Set RBW = 100 kHz.
2. Set VBW \geq 300 kHz.
3. Detector = peak.
4. Sweep = auto couple.
5. Trace Mode = max hold.
6. Allow trace to fully stabilize.
7. Use the peak marker function to determine the maximum amplitude level.

4.7.5 Deviation from Test Standard

No deviation.

4.7.6 EUT Operating Condition

The software provided by client to enable the EUT under transmission condition continuously at lowest, middle and highest channel frequencies individually.

4.7.7 Test Results

The spectrum plots are attached on the following images. D1 line indicates the highest level, and D2 line indicates the 20 dB offset below D1. It shows compliance with the requirement.

Mode A

802.11b

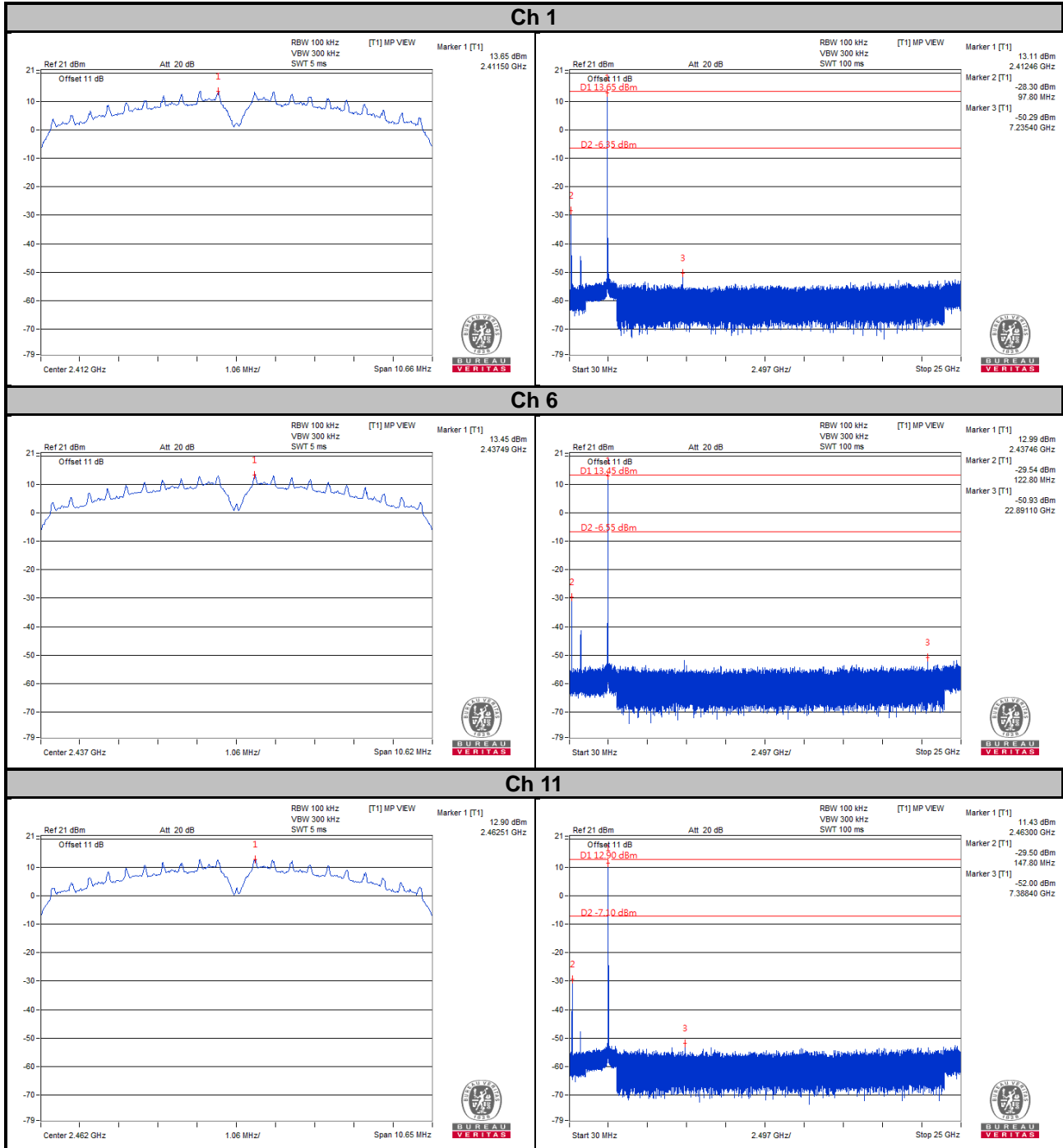

Ch 1 Band Edge

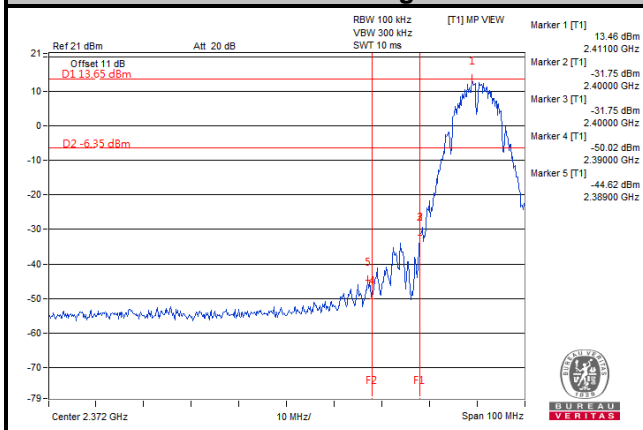

Ch 11 Band Edge

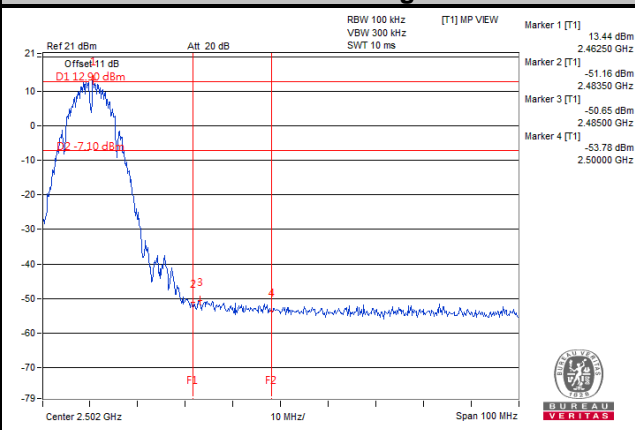

802.11g

Ch 1

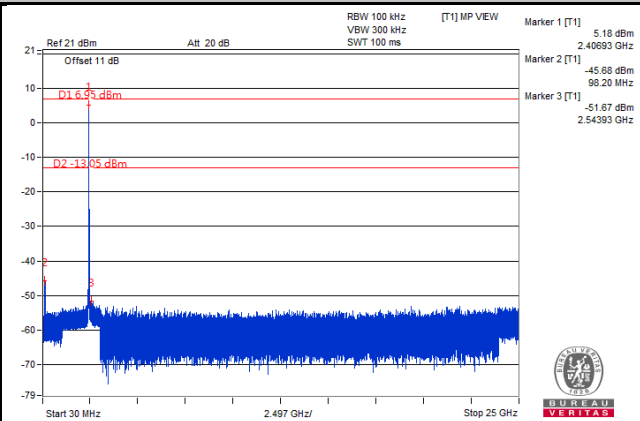
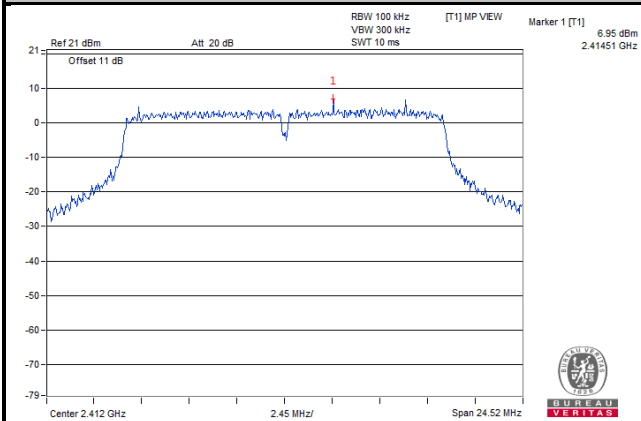

Ch 6

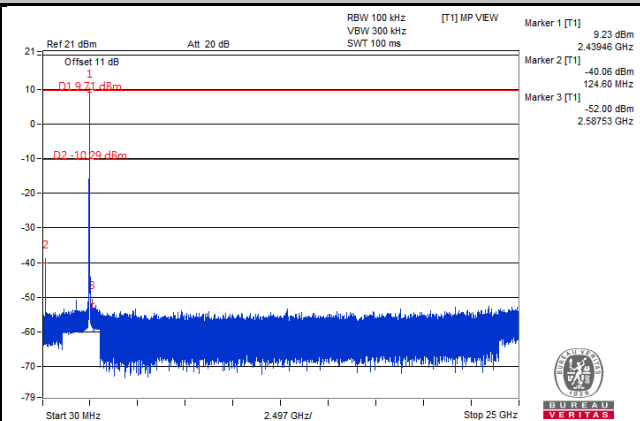
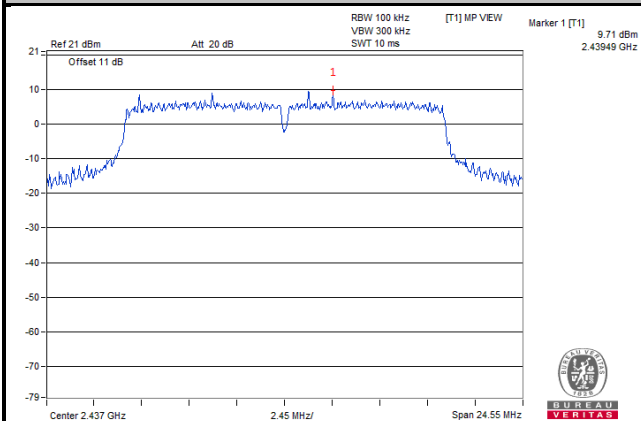

Ch 11

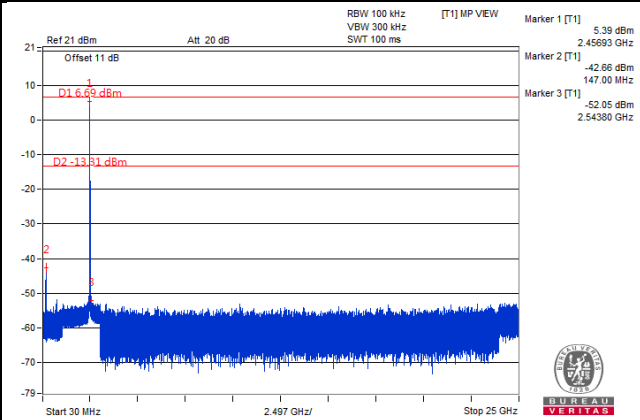
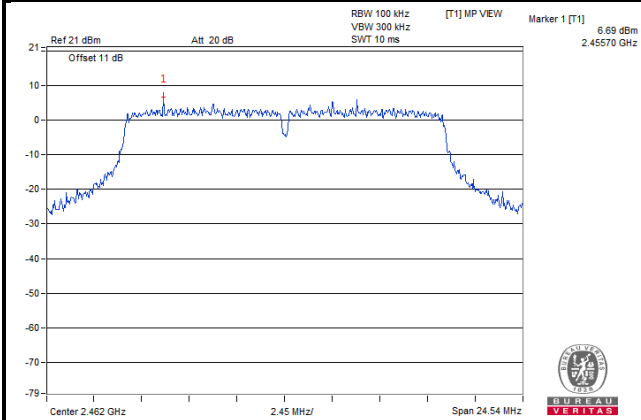

Ch 1 Band Edge

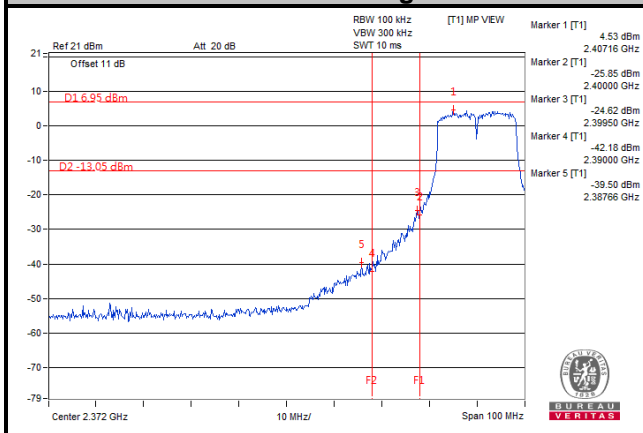

Ch 11 Band Edge

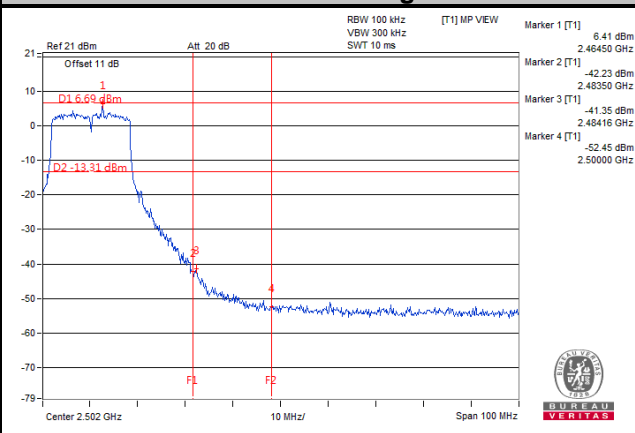

Mode B
802.11n (HT20)
CHAIN 0

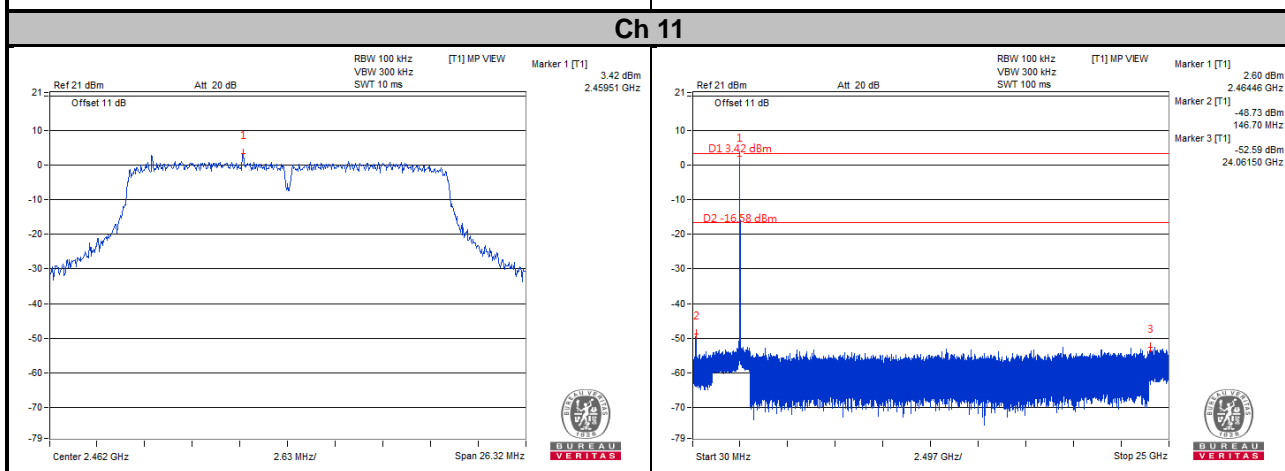
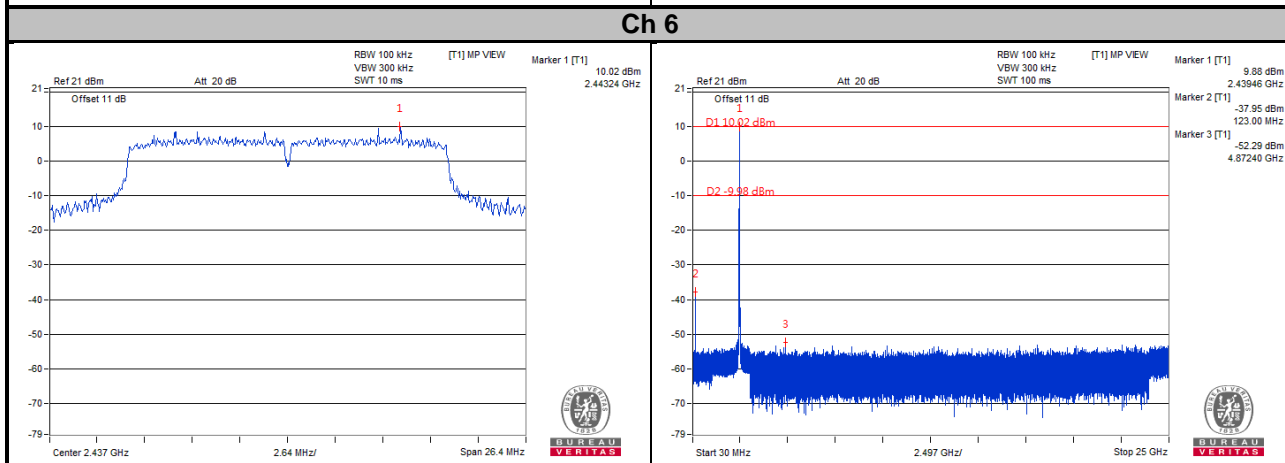
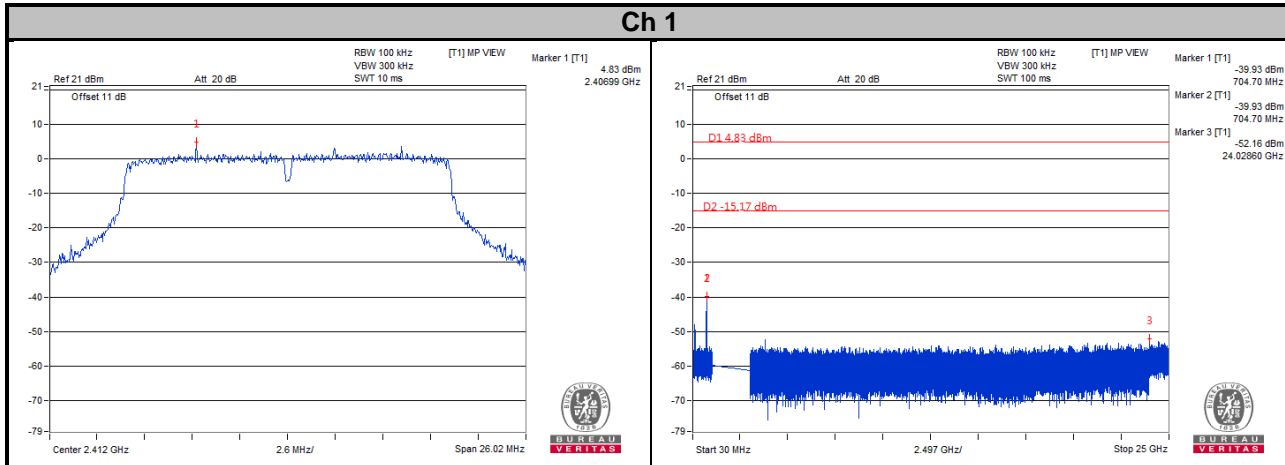

Ch 1 Band Edge

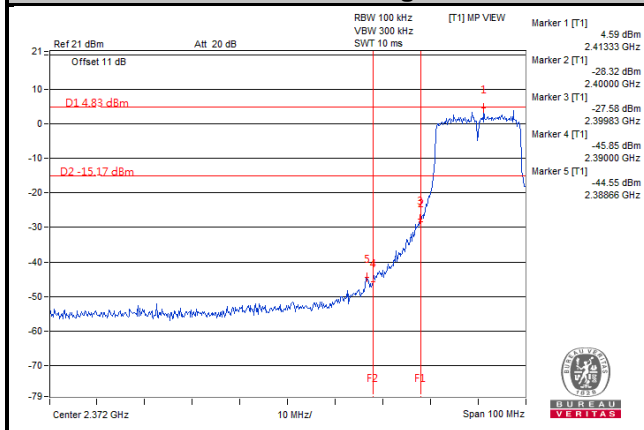

Ch 11 Band Edge

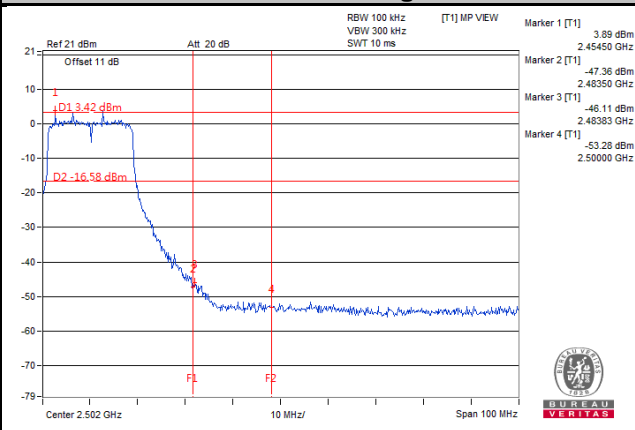

CHAIN 1

Ch 1

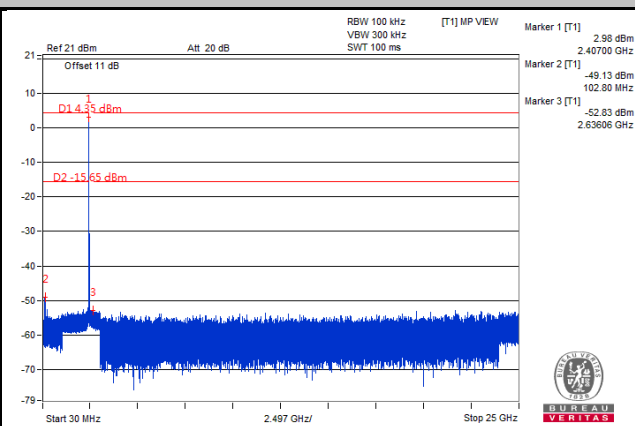
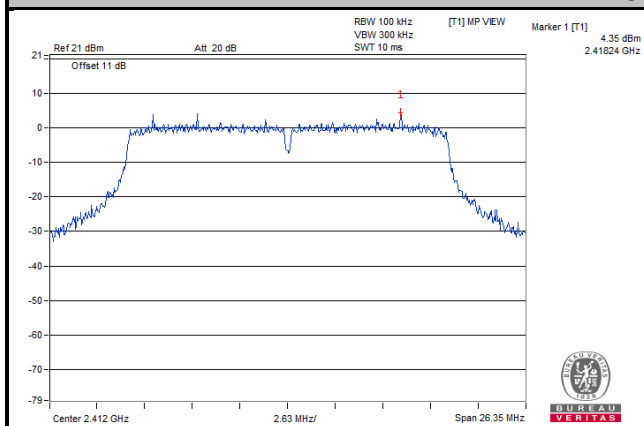

Ch 6

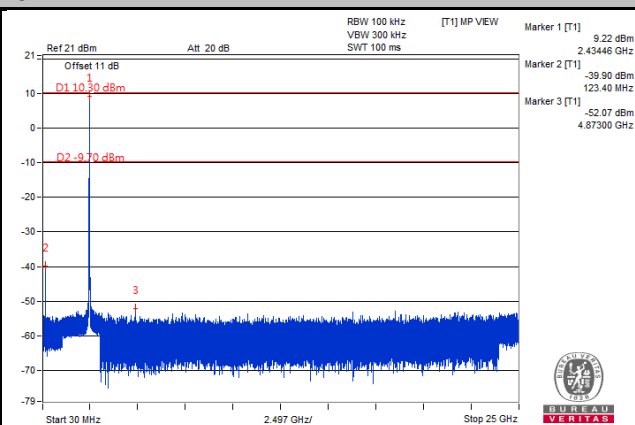
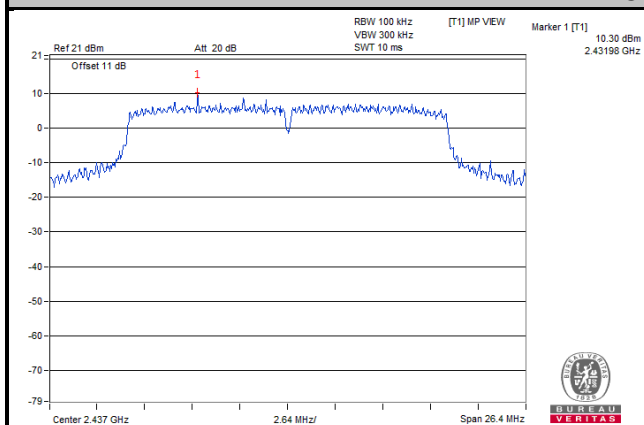

Ch 11

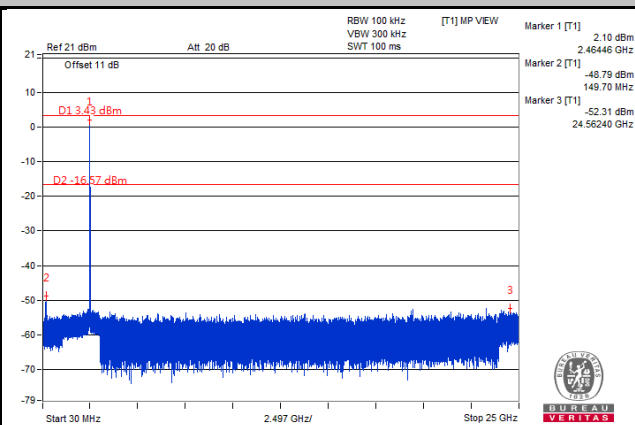
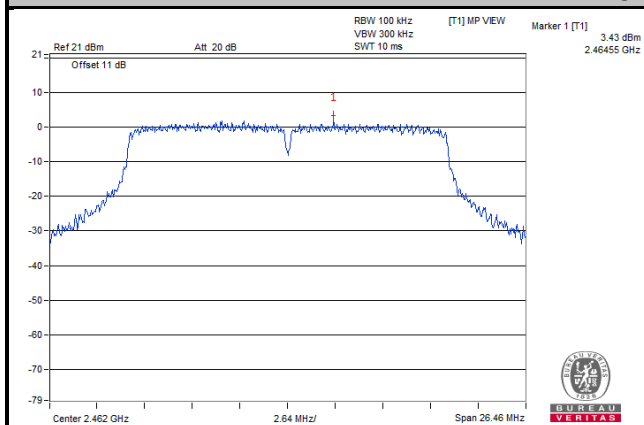

Ch 1 Band Edge

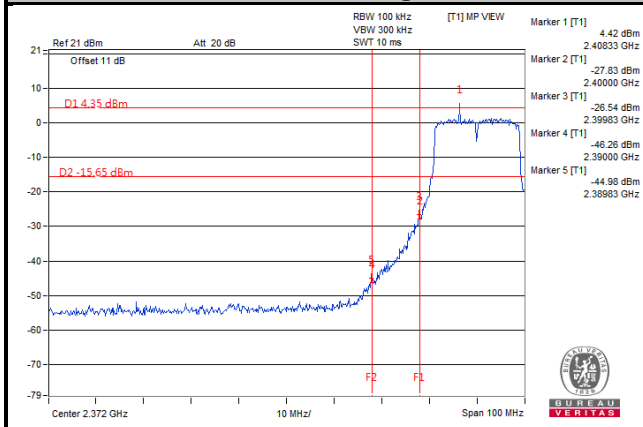

Ch 11 Band Edge

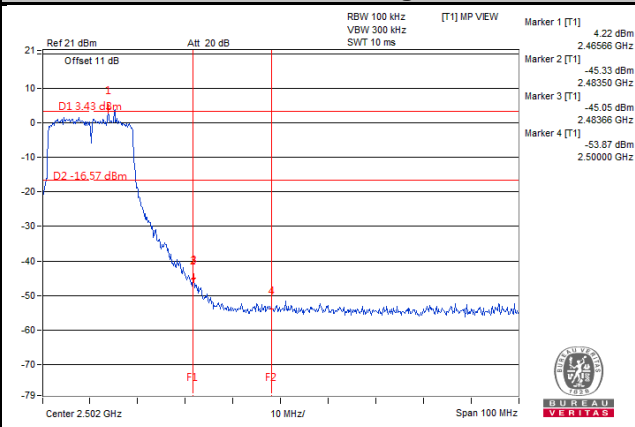

802.11n (HT40)
CHAIN 0

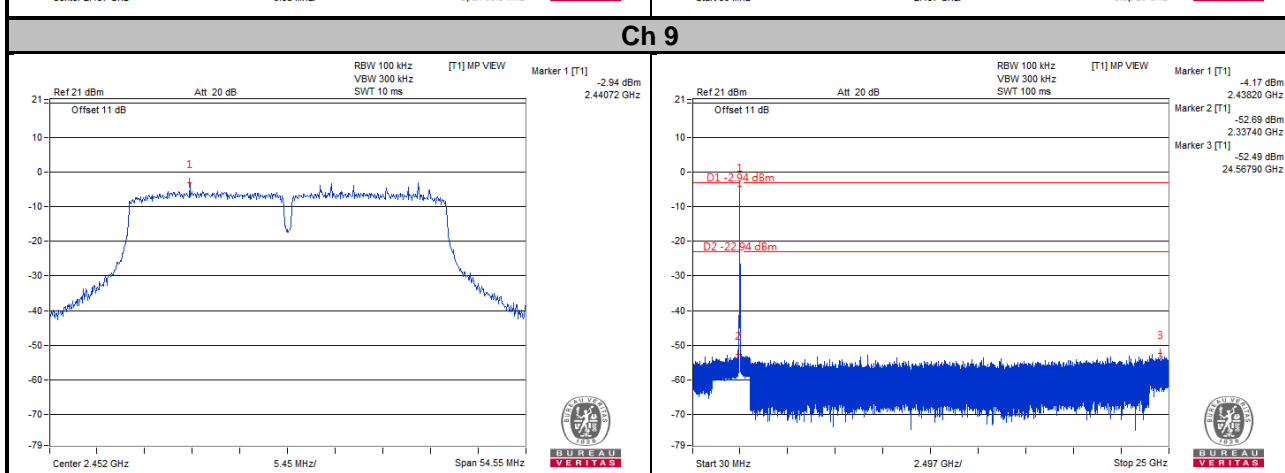
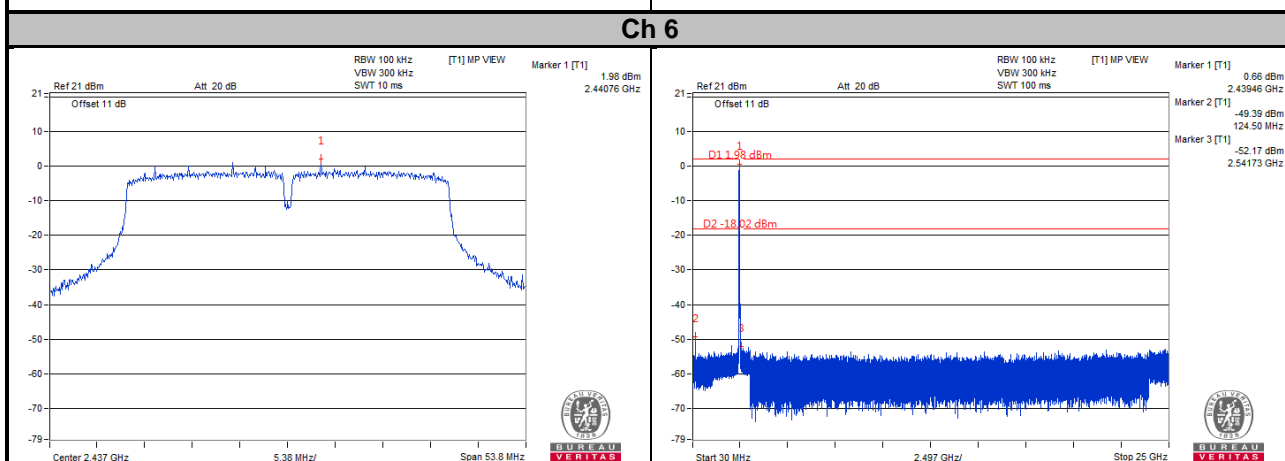
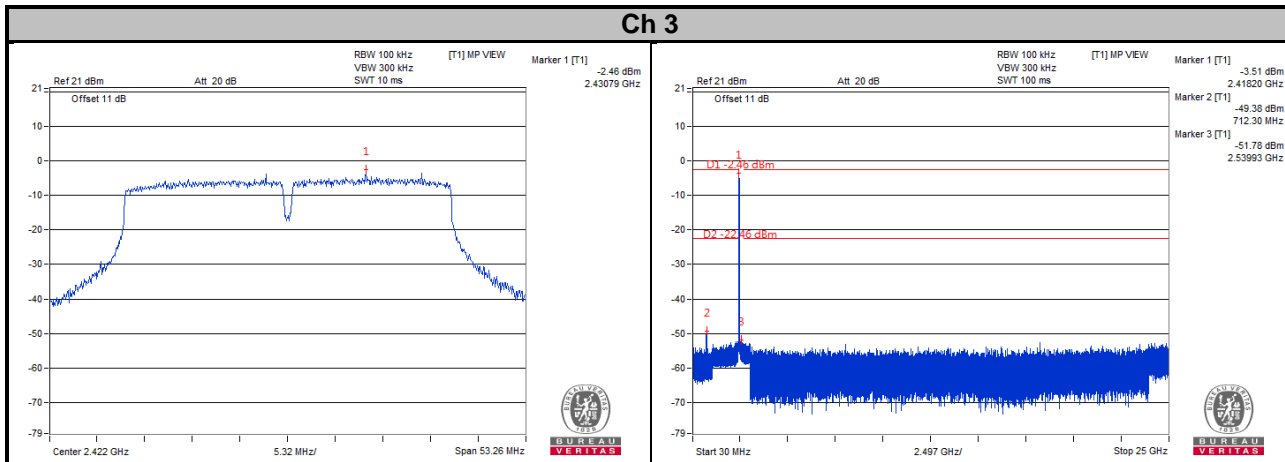

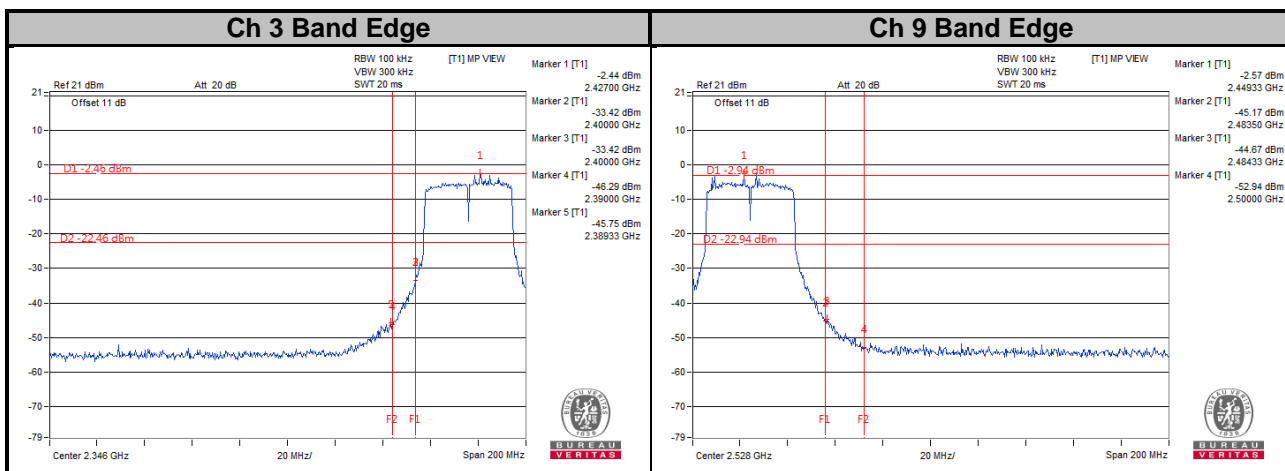

CHAIN 1

Ch 3

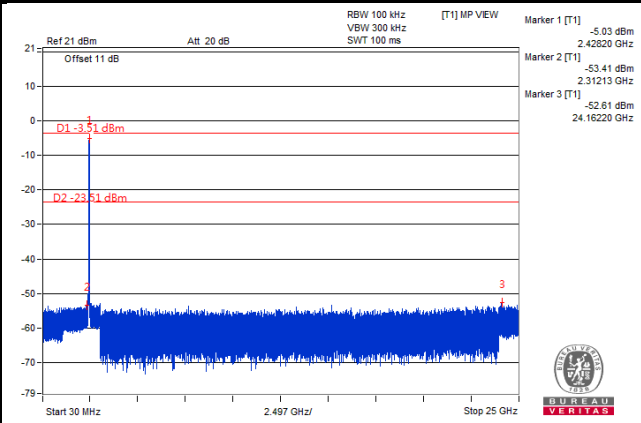
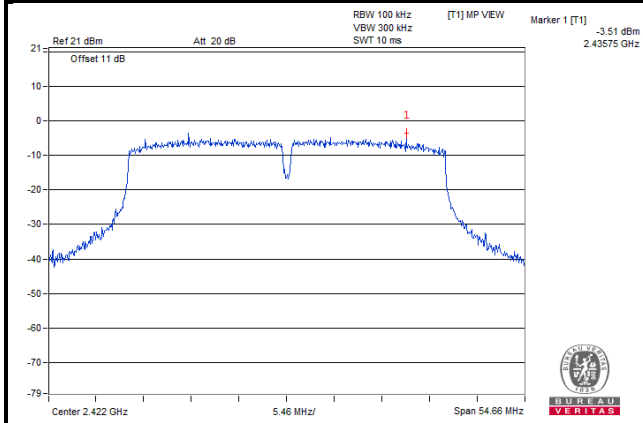

Ch 6

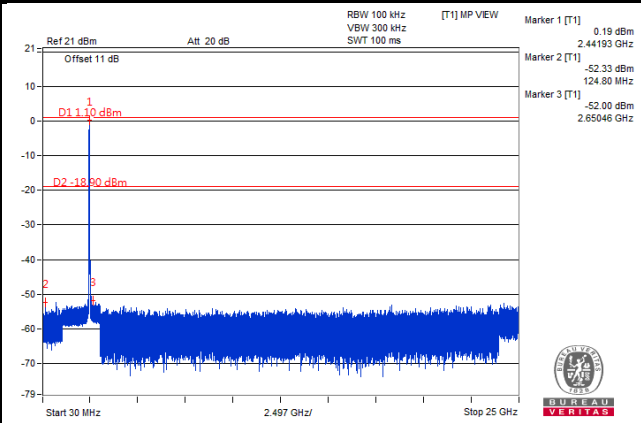
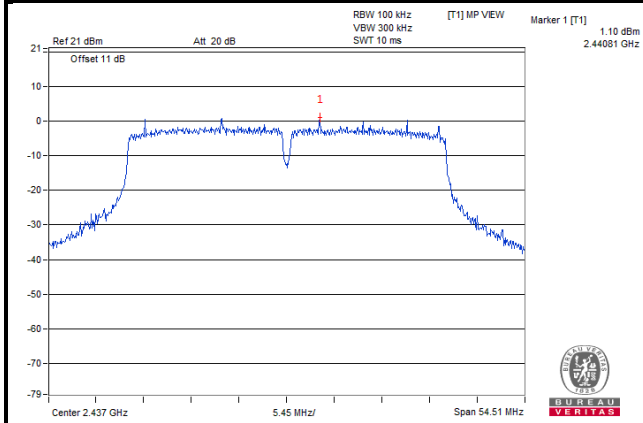

Ch 9

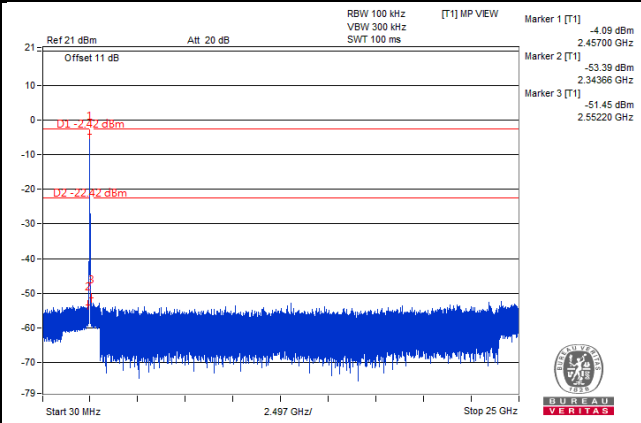
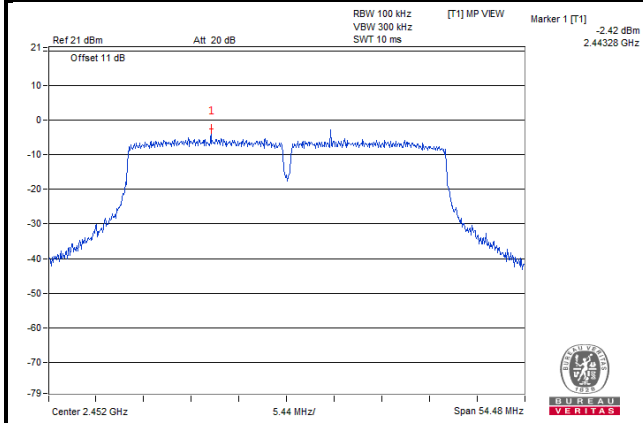

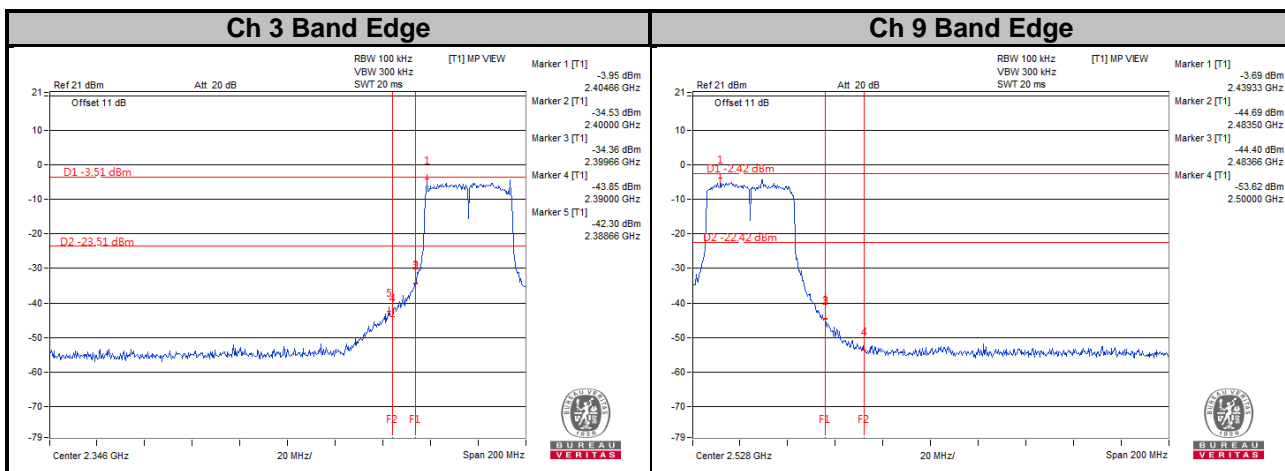

5 Pictures of Test Arrangements

Please refer to the attached file (Test Setup Photo).

Appendix – Information on the Testing Laboratories

We, Bureau Veritas Consumer Products Services (H.K.) Ltd., Taoyuan Branch, were founded in 1988 to provide our best service in EMC, Radio, Telecom and Safety consultation. Our laboratories are accredited and approved according to ISO/IEC 17025.

If you have any comments, please feel free to contact us at the following:

Linko EMC/RF Lab

Tel: 886-2-26052180

Fax: 886-2-26051924

Hsin Chu EMC/RF/Telecom Lab

Tel: 886-3-6668565

Fax: 886-3-6668323

Hwa Ya EMC/RF/Safety Lab

Tel: 886-3-3183232

Fax: 886-3-3270892

Email: service.adt@tw.bureauveritas.com

Web Site: www.bureauveritas-adt.com

The address and road map of all our labs can be found in our web site also.

--- END ---