

FCC Test Report

Report No.: RF160113C23-1

FCC ID: W23-JWX5253

Test Model: JWX6052, JWX6053

Received Date: Jan. 13, 2016

Test Date: Apr. 24, 2016 ~ May 04, 2016

Issued Date: May 16, 2016

Applicant: jjPlus CORP.

Address: 13F.-3, No.120, Qiaohe Rd., Zhonghe Dist., New Taipei City 235, Taiwan

Issued By: Bureau Veritas Consumer Products Services (H.K.) Ltd., Taoyuan Branch

Lab Address: No. 47-2, 14th Ling, Chia Pau Vil., Lin Kou Dist., New Taipei City, Taiwan
(R.O.C)

Test Location: No. 19, Hwa Ya 2nd Rd, Wen Hwa Tsuen, Kwei Shan Hsiang, Taoyuan
Hsien 333, Taiwan, R.O.C.



This report is for your exclusive use. Any copying or replication of this report to or for any other person or entity, or use of our name or trademark, is permitted only with our prior written permission. This report sets forth our findings solely with respect to the test samples identified herein. The results set forth in this report are not indicative or representative of the quality or characteristics of the lot from which a test sample was taken or any similar or identical product unless specifically and expressly noted. Our report includes all of the tests requested by you and the results thereof based upon the information that you provided to us. You have 60 days from date of issuance of this report to notify us of any material error or omission caused by our negligence, provided, however, that such notice shall be in writing and shall specifically address the issue you wish to raise. A failure to raise such issue within the prescribed time shall constitute your unqualified acceptance of the completeness of this report, the tests conducted and the correctness of the report contents. Unless specific mention, the uncertainty of measurement has been explicitly taken into account to declare the compliance or non-compliance to the specification. The report must not be used by the client to claim product certification, approval, or endorsement by TAF or any government agencies.

Table of Contents

Release Control Record	4
1 Certificate of Conformity	5
2 Summary of Test Results.....	6
2.1 Measurement Uncertainty.....	6
2.2 Modification Record	6
3 General Information	7
3.1 General Description of EUT	7
3.2 Description of Test Modes.....	8
3.2.1 Test Mode Applicability and Tested Channel Detail.....	10
3.3 Duty Cycle of Test Signal	12
3.4 Description of Support Units	16
3.4.1 Configuration of System under Test	16
3.5 General Description of Applied Standards.....	16
4 Test Types and Results	17
4.1 Radiated Emission and Bandedge Measurement	17
4.1.1 Limits of Radiated Emission and Bandedge Measurement	17
4.1.2 Limits of Unwanted Emission Out of the Restricted Bands	17
4.1.3 Test Instruments	18
4.1.4 Test Procedures.....	19
4.1.5 Deviation from Test Standard	19
4.1.6 Test Set Up	20
4.1.7 EUT Operating Conditions.....	20
4.1.8 Test Results	21
4.2 Conducted Emission Measurement.....	63
4.2.1 Limits of Conducted Emission Measurement	63
4.2.2 Test Instruments	63
4.2.3 Test Procedures.....	64
4.2.4 Deviation from Test Standard	64
4.2.5 Test Setup.....	64
4.2.6 EUT Operating Conditions.....	64
4.2.7 Test Results	65
4.3 Transmit Power Measurement.....	67
4.3.1 Limits of Transmit Power Measurement	67
4.3.2 Test Setup.....	67
4.3.3 Test Instruments	68
4.3.4 Test Procedure	68
4.3.5 Deviation from Test Standard	68
4.3.6 EUT Operating Conditions.....	68
4.3.7 Test Result	69
4.4 Peak Power Spectral Density Measurement	75
4.4.1 Limits of Peak Power Spectral Density Measurement	75
4.4.2 Test Setup.....	75
4.4.3 Test Instruments	75
4.4.4 Test Procedures.....	75
4.4.5 Deviation from Test Standard	76
4.4.6 EUT Operating Conditions.....	76
4.4.7 Test Results	76
4.5 Frequency Stability	83
4.5.1 Limit of Frequency Stability Measurement	83
4.5.2 Test Setup.....	83
4.5.3 Test Instruments	83
4.5.4 Test Procedure	83
4.5.5 Deviation from Test Standard	83

4.5.6 EUT Operating Condition	83
4.5.7 Test Results	84
4.6 6 dB Bandwidth Measurement.....	85
4.6.1 Limits of 6 dB Bandwidth Measurement.....	85
4.6.2 Test Setup.....	85
4.6.3 Test Instruments	85
4.6.4 Test Procedure	85
4.6.5 Deviation from Test Standard	85
4.6.6 EUT Operating Condition	85
4.6.7 Test Results	86
5 Pictures of Test Arrangements.....	88
Appendix – Information on the Testing Laboratories	89

Release Control Record

Issue No.	Description	Date Issued
RF160113C23-1	Original Release	May 16, 2016

1 Certificate of Conformity

Product: 802.11a/b/g/n/ac 3T3R Mini-PCI-Express Module

Brand: jjPlus

Test Model: JWX6052, JWX6053

Sample Status: Identical Prototype

Applicant: jjPlus CORP.

Test Date: Apr. 24, 2016 ~ May 04, 2016

Standards: 47 CFR FCC Part 15, Subpart E (Section 15.407)
ANSI C63.10:2013

The above equipment has been tested by **Bureau Veritas Consumer Products Services (H.K.) Ltd., Taoyuan Branch**, and found compliance with the requirement of the above standards. The test record, data evaluation & Equipment Under Test (EUT) configurations represented herein are true and accurate accounts of the measurements of the sample's EMC characteristics under the conditions specified in this report.

Prepared by : Evonne Liu, **Date:** May 16, 2016
Evonne Liu / Specialist

Approved by : Stanley Wu, **Date:** May 16, 2016
Stanley Wu / Assistant Manager

2 Summary of Test Results

47 CFR FCC Part 15, Subpart E (Section 15.407)			
FCC Clause	Test Item	Result	Remarks
15.407(b)(6)	AC Power Conducted Emissions	Pass	Meet the requirement of limit. Minimum passing margin is -13.16 dB at 0.20201 MHz.
15.407(b) (1/2/3/4/6)	Radiated Emissions & Band Edge Measurement	Pass	Meet the requirement of limit. Minimum passing margin is -1.01 dB at 5470 MHz.
15.407(a)(1/2 /3)	Max Average Transmit Power	Pass	Meet the requirement of limit.
15.407(a)(1/2 /3)	Peak Power Spectral Density	Pass	Meet the requirement of limit.
15.407(e)	6 dB Bandwidth	Pass	Meet the requirement of limit. (U-NII-3 Band only)
15.407(g)	Frequency Stability	Pass	Meet the requirement of limit.
15.203	Antenna Requirement	Pass	No antenna connector is used.

2.1 Measurement Uncertainty

Where relevant, the following measurement uncertainty levels have been estimated for tests performed on the EUT as specified in CISPR 16-4-2:

Measurement	Frequency	Expanded Uncertainty (k=2) (±)
Conducted Emissions at mains ports	150 kHz ~ 30 MHz	2.44 dB
Radiated Emissions up to 1 GHz	30 MHz ~ 200 MHz	2.93 dB
	200 MHz ~ 1000 MHz	2.95 dB
Radiated Emissions above 1 GHz	1 GHz ~ 18 GHz	2.26 dB
	18 GHz ~ 40 GHz	1.94 dB

2.2 Modification Record

There were no modifications required for compliance.

3 General Information

3.1 General Description of EUT

Product	802.11a/b/g/n/ac 3T3R Mini-PCI-Express Module
Brand	jjPlus
Test Model	JWX6052, JWX6053
Status of EUT	Identical Prototype
Power Supply Rating	3.3 Vdc (host equipment)
Modulation Type	256QAM, 64QAM, 16QAM, QPSK, BPSK
Modulation Technology	OFDM
Transfer Rate	802.11a: 54.0/ 48.0/ 36.0/ 24.0/ 18.0/ 12.0/ 9.0/ 6.0 Mbps 802.11n: up to MCS7 802.11ac: up to V9
Operating Frequency	5180 ~ 5240 MHz, 5260 ~ 5320 MHz, 5500 ~ 5700 MHz, 5745 ~ 5825 MHz
Number of Channel	5180 ~ 5240 MHz: 4 for 802.11a, 802.11n (HT20) 2 for 802.11n (HT40) 1 for 802.11ac (VHT80) 5260 ~ 5320 MHz: 4 for 802.11a, 802.11n (HT20) 2 for 802.11n (HT40) 1 for 802.11ac (VHT80) 5500 ~ 5700 MHz: 11 for 802.11a, 802.11n (HT20) 5 for 802.11n (HT40) 2 for 802.11ac (VHT80) 5745 ~ 5825 MHz: 5 for 802.11a, 802.11n (HT20) 2 for 802.11n (HT40) 1 for 802.11ac (VHT80)
Output Power	123.54 mW for 5180 ~ 5240 MHz 120.27 mW for 5260 ~ 5320 MHz 120.93 mW for 5500 ~ 5700 MHz 127.294 mW for 5745 ~ 5825 MHz
Antenna Type	Omni antenna with 5 dBi gain (5180 ~ 5240 MHz) Omni antenna with 5 dBi gain (5260 ~ 5320 MHz) Omni antenna with 5 dBi gain (5500 ~ 5700 MHz) Omni antenna with 5 dBi gain (5745 ~ 5825 MHz)
Antenna Connector	N/A
Accessory Device	Refer to Note as below
Data Cable Supplied	Refer to Note as below

Note:

1. All models are listed as below.

Brand	Model	Difference
jjPlus	JWX6052	The difference between two model names is temperature operating range only. Other specification is the same.
	JWX6053	

*Model of 'JWX6053' was chosen for final test.

2. The EUT incorporates a MIMO function. Physically, the EUT provides three completed transmitters and three receivers.

Modulation Mode	Tx Function
802.11a	1TX
802.11n (HT20)	3TX
802.11n (HT40)	3TX
802.11ac (VHT80)	3TX

* The modulation and bandwidth are similar for 802.11n mode for HT20 / HT40 and 802.11ac mode for HT20 / HT40, therefore investigated worst case to representative mode in test report. (Final test mode refer section 3.2.1)

3. The above EUT information is declared by manufacturer and for more detailed features description, please refer to the manufacturer's specifications or user's manual.

3.2 Description of Test Modes

FOR 5180 ~ 5240 MHz

4 channels are provided for 802.11a, 802.11n (HT20):

Channel	Frequency (MHz)	Channel	Frequency (MHz)
36	5180	44	5220
40	5200	48	5240

2 channels are provided for 802.11n (HT40):

Channel	Frequency (MHz)	Channel	Frequency (MHz)
38	5190	46	5230

1 channel is provided for 802.11ac (VHT80):

Channel	Frequency (MHz)
42	5210

FOR 5260 ~ 5320 MHz

4 channels are provided for 802.11a, 802.11n (HT20):

Channel	Frequency (MHz)	Channel	Frequency (MHz)
52	5260	60	5300
56	5280	64	5320

2 channels are provided for 802.11n (HT40):

Channel	Frequency (MHz)	Channel	Frequency (MHz)
54	5270	62	5310

1 channel is provided for 802.11ac (VHT80):

Channel	Frequency (MHz)
58	5290

FOR 5500 ~ 5700 MHz

11 channels are provided for 802.11a, 802.11n (HT20):

Channel	Frequency (MHz)	Channel	Frequency (MHz)
100	5500	124	5620
104	5520	128	5640
108	5540	132	5660
112	5560	136	5680
116	5580	140	5700
120	5600		

5 channels are provided for 802.11n (HT40):

Channel	Frequency (MHz)	Channel	Frequency (MHz)
102	5510	126	5630
110	5550	134	5670
118	5590		

2 channels are provided for 802.11ac (VHT80):

Channel	Frequency (MHz)	Channel	Frequency (MHz)
106	5530	122	5610

FOR 5745 ~ 5825 MHz:

5 channels are provided for 802.11a, 802.11n (HT20):

Channel	Frequency (MHz)	Channel	Frequency (MHz)
149	5745	161	5805
153	5765	165	5825
157	5785		

2 channels are provided for 802.11n (HT40):

Channel	Frequency (MHz)	Channel	Frequency (MHz)
151	5755	159	5795

1 channel is provided for 802.11ac (VHT80):

Channel	Frequency (MHz)
155	5775

3.2.1 Test Mode Applicability and Tested Channel Detail

EUT Configure Mode	Applicable To				Description
	RE \geq 1G	RE $<$ 1G	PLC	APCM	
A	√	-	-	√	1TX
B	√	√	√	√	3TX

Where **RE \geq 1G**: Radiated Emission above 1 GHz **RE $<$ 1G**: Radiated Emission below 1 GHz
PLC: Power Line Conducted Emission **APCM**: Antenna Port Conducted Measurement

NOTE: "-" means no effect.

Radiated Emission Test (Above 1 GHz):

- Pre-Scan has been conducted to determine the worst-case mode from all possible combinations between available modulations, data rates and antenna ports (if EUT with antenna diversity architecture).
- Following channel(s) was (were) selected for the final test as listed below.

EUT Configure Mode	Frequency Band (MHz)	Mode	Available Channel	Tested Channel	Modulation Technology	Modulation Type	Data Rate (Mbps)
A	5180-5240	802.11a	36 to 48	36, 44, 48	OFDM	BPSK	6.0
B		802.11n (HT20)	36 to 48	36, 44, 48	OFDM	BPSK	MCS0
		802.11n (HT40)	38 to 46	38, 46	OFDM	BPSK	MCS0
		802.11ac (VHT80)	42	42	OFDM	BPSK	V0
A	5260-5320	802.11a	52 to 64	52, 60, 64	OFDM	BPSK	6.0
B		802.11n (HT20)	52 to 64	52, 60, 64	OFDM	BPSK	MCS0
		802.11n (HT40)	54 to 62	54, 62	OFDM	BPSK	MCS0
		802.11ac (VHT80)	58	58	OFDM	BPSK	V0
A	5500-5700	802.11a	100 to 140	100, 116, 140	OFDM	BPSK	6.0
B		802.11n (HT20)	100 to 140	100, 116, 140	OFDM	BPSK	MCS0
		802.11n (HT40)	102 to 134	102, 110, 134	OFDM	BPSK	MCS0
		802.11ac (VHT80)	106 to 122	106, 122	OFDM	BPSK	V0
A	5745-5825	802.11a	149 to 165	149, 157, 165	OFDM	BPSK	6.0
B		802.11n (HT20)	149 to 165	149, 157, 165	OFDM	BPSK	MCS0
		802.11n (HT40)	151 to 159	151, 159	OFDM	BPSK	MCS0
		802.11ac (VHT80)	155	155	OFDM	BPSK	V0

Radiated Emission Test (Below 1 GHz):

- Pre-Scan has been conducted to determine the worst-case mode from all possible combinations between available modulations, data rates and antenna ports (if EUT with antenna diversity architecture).
- Following channel(s) was (were) selected for the final test as listed below.

EUT Configure Mode	Frequency Band (MHz)	Mode	Available Channel	Tested Channel	Modulation Technology	Modulation Type	Data Rate (Mbps)
B	5180-5240	802.11n (HT40)	38 to 46	38	OFDM	BPSK	MCS0
	5260-5320	802.11n (HT40)	54 to 62	62	OFDM	BPSK	MCS0
	5500-5700	802.11n (HT40)	102 to 134	102	OFDM	BPSK	MCS0
	5745-5825	802.11n (HT40)	151 to 159	151	OFDM	BPSK	MCS0

Power Line Conducted Emission Test:

Pre-Scan has been conducted to determine the worst-case mode from all possible combinations between available modulations, data rates and antenna ports (if EUT with antenna diversity architecture).

Following channel(s) was (were) selected for the final test as listed below.

EUT Configure Mode	Frequency Band (MHz)	Mode	Available Channel	Tested Channel	Modulation Technology	Modulation Type	Data Rate (Mbps)
B	5500-5700	802.11n (HT40)	102 to 134	102	OFDM	BPSK	MCS0

Antenna Port Conducted Measurement:

This item includes all test value of each mode, but only includes spectrum plot of worst value of each mode.

Pre-Scan has been conducted to determine the worst-case mode from all possible combinations between available modulations, data rates and antenna ports (if EUT with antenna diversity architecture).

Following channel(s) was (were) selected for the final test as listed below.

EUT Configure Mode	Frequency Band (MHz)	Mode	Available Channel	Tested Channel	Modulation Technology	Modulation Type	Data Rate (Mbps)
A	5180-5240	802.11a	36 to 48	36, 44, 48	OFDM	BPSK	6.0
B		802.11n (HT20)	36 to 48	36, 44, 48	OFDM	BPSK	MCS0
		802.11n (HT40)	38 to 46	38, 46	OFDM	BPSK	MCS0
		802.11ac (VHT80)	42	42	OFDM	BPSK	V0
A	5260-5320	802.11a	52 to 64	52, 60, 64	OFDM	BPSK	6.0
B		802.11n (HT20)	52 to 64	52, 60, 64	OFDM	BPSK	MCS0
		802.11n (HT40)	54 to 62	54, 62	OFDM	BPSK	MCS0
		802.11ac (VHT80)	58	58	OFDM	BPSK	V0
A	5500-5700	802.11a	100 to 140	100, 116, 140	OFDM	BPSK	6.0
B		802.11n (HT20)	100 to 140	100, 116, 140	OFDM	BPSK	MCS0
		802.11n (HT40)	102 to 134	102, 110, 134	OFDM	BPSK	MCS0
		802.11ac (VHT80)	106 to 122	106, 122	OFDM	BPSK	V0
A	5745-5825	802.11a	149 to 165	149, 157, 165	OFDM	BPSK	6.0
B		802.11n (HT20)	149 to 165	149, 157, 165	OFDM	BPSK	MCS0
		802.11n (HT40)	151 to 159	151, 159	OFDM	BPSK	MCS0
		802.11ac (VHT80)	155	155	OFDM	BPSK	V0

Test Condition:

Applicable To	Environmental Conditions	Input Power	Tested by
RE≥1G	25 deg. C, 65 % RH	120 Vac, 60 Hz	Gavin Wu
RE<1G	25 deg. C, 65 % RH	120 Vac, 60 Hz	Gavin Wu
PLC	25 deg. C, 65 % RH	120 Vac, 60 Hz	Toby Tian
APCM	25 deg. C, 65 % RH	3.3 Vdc	Taylor Liu

3.3 Duty Cycle of Test Signal

MODULATION TYPE: BPSK

Duty cycle of test signal is < 98 %, duty factor is required.

802.11a: Duty cycle = 1.883/1.963 = 0.959, Duty factor = $10 * \log(1/0.959) = 0.18$

802.11n (HT20): Duty cycle = 2.019/2.107 = 0.958, Duty factor = $10 * \log(1/0.958) = 0.19$

802.11n (HT40): Duty cycle = 0.889/1.001 = 0.888, Duty factor = $10 * \log(1/0.888) = 0.52$

802.11ac (VHT80): Duty cycle = 424/520 = 0.815, Duty factor = $10 * \log(1/0.815) = 0.89$

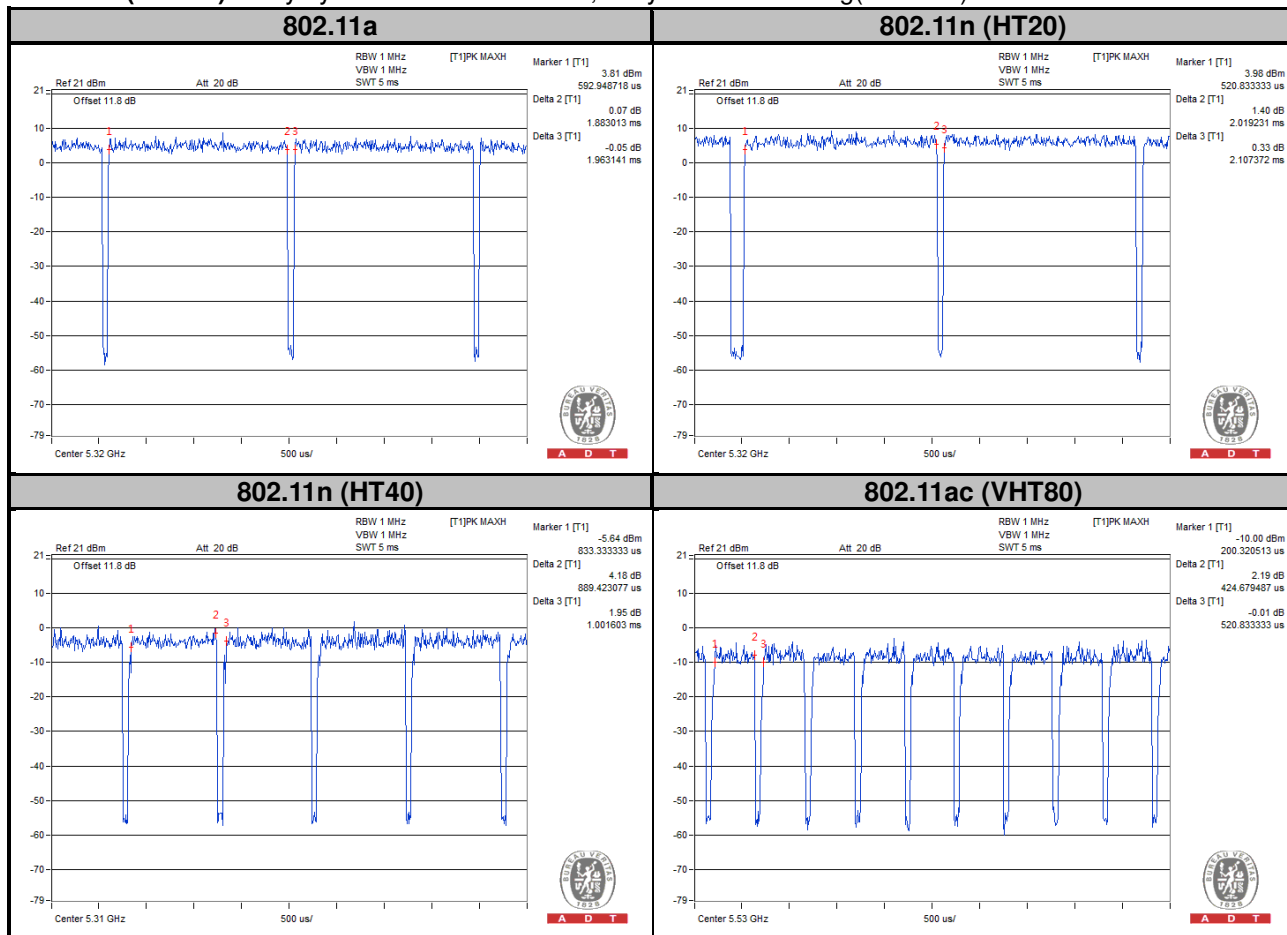

MODULATION TYPE: QPSK

Duty cycle of test signal is < 98 %, duty factor is required.

802.11a: Duty cycle = $1.017/1.089 = 0.933$, Duty factor = $10 * \log(1/0.933) = 0.30$

802.11n (HT20): Duty cycle = $0.953/1.033 = 0.922$, Duty factor = $10 * \log(1/0.922) = 0.35$

802.11n (HT40): Duty cycle = $448/552 = 0.811$, Duty factor = $10 * \log(1/0.811) = 0.91$

802.11ac (VHT80): Duty cycle = $216/315 = 0.692$, Duty factor = $10 * \log(1/0.692) = 1.60$



MODULATION TYPE: 16QAM

Duty cycle of test signal is < 98 %, duty factor is required.

802.11a: Duty cycle = 512/592 = 0.864, Duty factor = $10 * \log(1/0.864) = 0.63$

802.11n (HT20): Duty cycle = 488/568 = 0.859, Duty factor = $10 * \log(1/0.859) = 0.66$

802.11n (HT40): Duty cycle = 224/328 = 0.682, Duty factor = $10 * \log(1/0.682) = 1.66$

802.11ac (VHT80): Duty cycle = 113/206 = 0.550, Duty factor = $10 * \log(1/0.550) = 2.59$

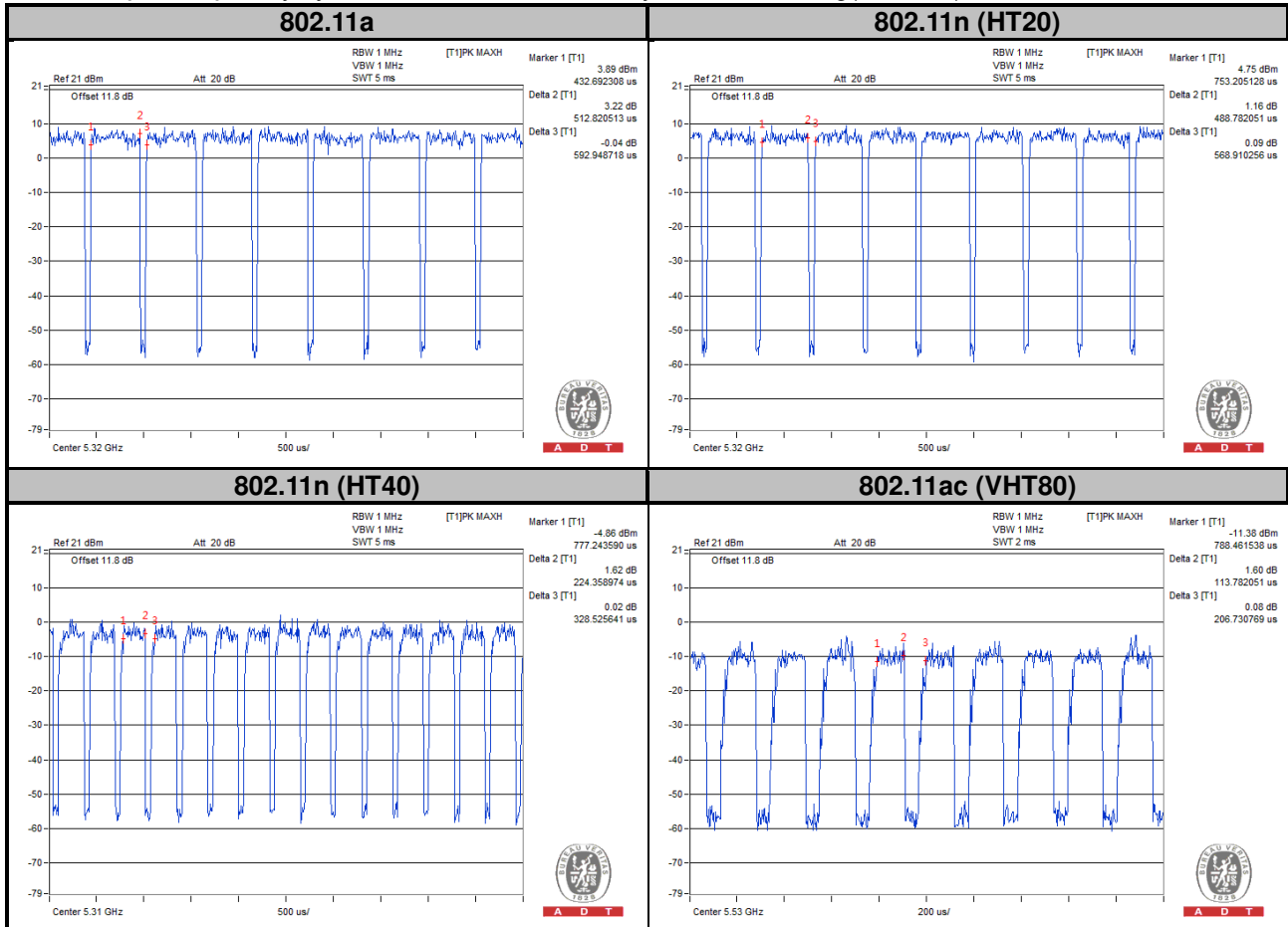

MODULATION TYPE: 64QAM

Duty cycle of test signal is < 98 %, duty factor is required.

802.11a: Duty cycle = 264/336 = 0.785, Duty factor = $10 \cdot \log(1/0.785) = 1.05$

802.11n (HT20): Duty cycle = 256/336 = 0.761, Duty factor = $10 \cdot \log(1/0.761) = 1.18$

802.11n (HT40): Duty cycle = 104/208 = 0.500, Duty factor = $10 \cdot \log(1/0.500) = 3.01$

802.11ac (VHT80): Duty cycle = 59/155 = 0.381, Duty factor = $10 \cdot \log(1/0.381) = 4.19$

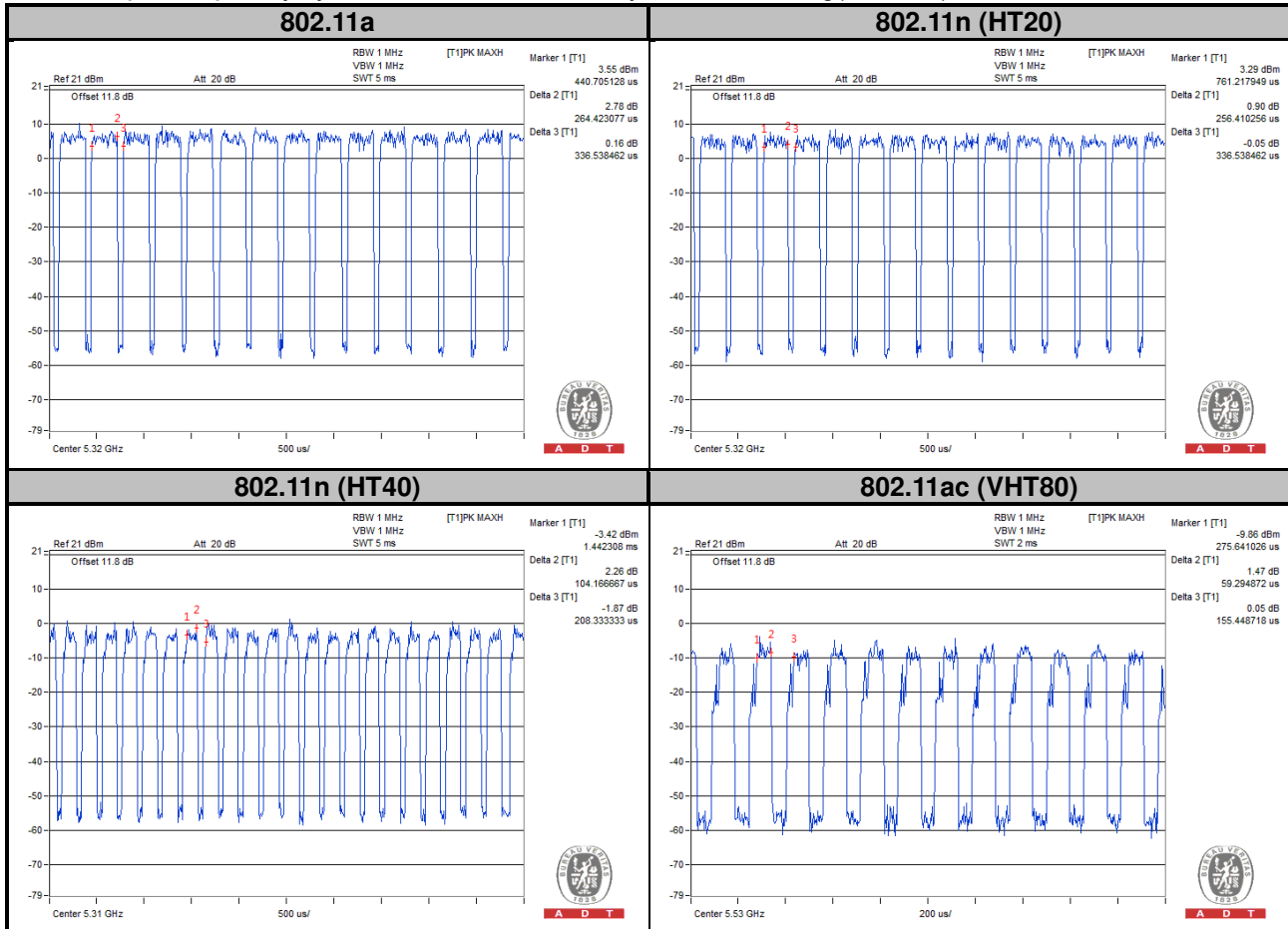

MODULATION TYPE: 256QAM

Duty cycle of test signal is < 98 %, duty factor is required.

802.11ac (VHT80): Duty cycle = 40/139 = 0.287, Duty factor = $10 \cdot \log(1/0.287) = 5.42$

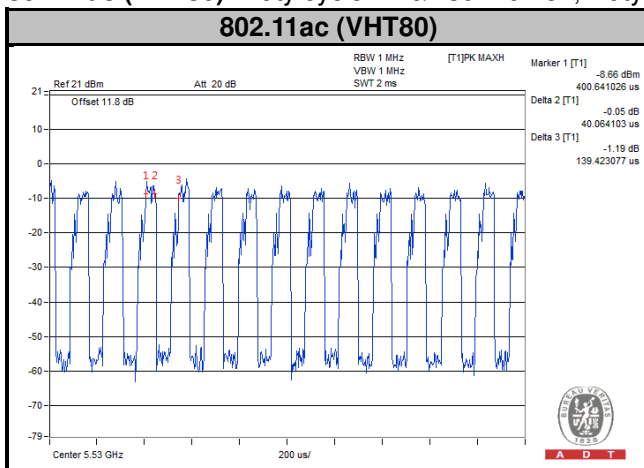

3.4 Description of Support Units

The EUT has been tested as an independent unit together with other necessary accessories or support units. The following support units or accessories were used to form a representative test configuration during the tests.

No.	Product	Brand	Model No.	Serial No.	FCC ID
1.	Notebook	DELL	E5420	8BHF5S1	N/A
2.	Ant* 3	N/A	N/A	N/A	N/A

No.	Signal Cable Description Of The Above Support Units
1.	N/A
2.	N/A

Note:

1. All power cords of the above support units are non-shielded (1.8m).

3.4.1 Configuration of System under Test

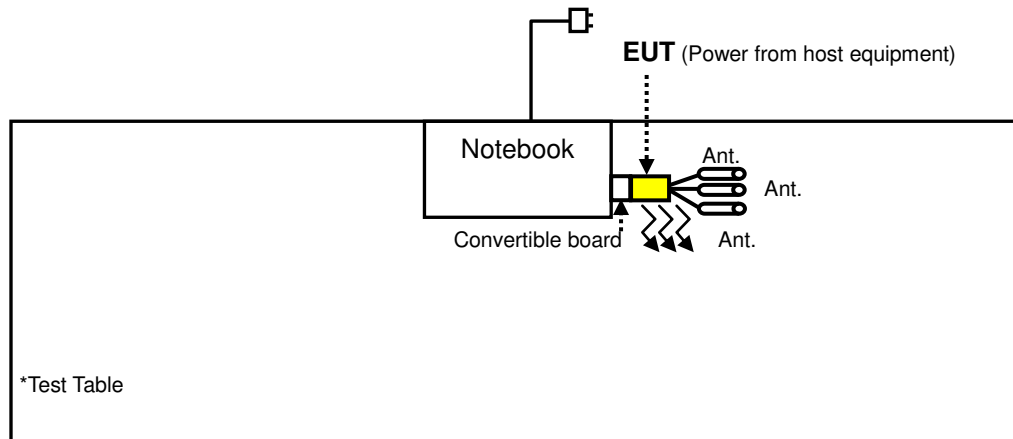

3.5 General Description of Applied Standards

The EUT is a RF Product. According to the specifications of the manufacturer, it must comply with the requirements of the following standards:

FCC Part 15, Subpart E (15.407)

789033 D02 General UNII Test Procedures New Rules v01r02

644545 D01 Guidance for IEEE 802 11ac v01r02

662911 D01 Multiple Transmitter Output v02r01

ANSI C63.10-2013

All test items have been performed and recorded as per the above standards.

NOTE: The EUT has been verified to comply with the requirements of FCC Part 15, Subpart B, Class B (DoC). The test report has been issued separately.

4 Test Types and Results

4.1 Radiated Emission and Bandedge Measurement

4.1.1 Limits of Radiated Emission and Bandedge Measurement

Radiated emissions which fall in the restricted bands must comply with the radiated emission limits specified as below table. Other emissions shall be at least 20 dB below the highest level of the desired power:

Frequencies (MHz)	Field Strength (microvolts/meter)	Measurement Distance (meters)
0.009 ~ 0.490	2400/F (kHz)	300
0.490 ~ 1.705	24000/F (kHz)	30
1.705 ~ 30.0	30	30
30 ~ 88	100	3
88 ~ 216	150	3
216 ~ 960	200	3
Above 960	500	3

NOTE:

1. The lower limit shall apply at the transition frequencies.
2. Emission level (dBuV/m) = 20 log Emission level (uV/m).
3. For frequencies above 1000 MHz, the field strength limits are based on average detector, however, the peak field strength of any emission shall not exceed the maximum permitted average limits, specified above by more than 20 dB under any condition of modulation.

4.1.2 Limits of Unwanted Emission Out of the Restricted Bands

Applicable To	Limit	
789033 D02 General UNII Test Procedures New Rules v01r02	Field Strength at 3 m	
	PK: 74 (dBμV/m)	AV: 54 (dBμV/m)
Applicable To	EIRP Limit	Equivalent Field Strength at 3 m
15.407(b)(1)	PK: -27 (dBm/MHz)	PK: 68.2 (dBμV/m)
15.407(b)(2)		
15.407(b)(3)		
15.407(b)(4)	PK: -27 (dBm/MHz) ^{*1} PK: -17 (dBm/MHz) ^{*2}	PK: 68.2 (dBμV/m) ^{*1} PK: 78.2 (dBμV/m) ^{*2}

NOTE: ^{*1} beyond 10 MHz of the band edge ^{*2} within 10 MHz of band edge

The following formula is used to convert the equipment isotropic radiated power (eirp) to field strength:

$$E = \frac{1000000\sqrt{30P}}{3} \mu\text{V/m, where } P \text{ is the eirp (Watts).}$$

4.1.3 Test Instruments

Description & Manufacturer	Model No.	Serial No.	Date of Calibration	Due Date of Calibration
Test Receiver Agilent	N9038A	MY51210203	Jan. 21, 2016	Jan. 20, 2017
Spectrum Analyzer Agilent	N9010A	MY52220314	Sep. 03, 2015	Sep. 02, 2016
Spectrum Analyzer ROHDE & SCHWARZ	FSU43	101261	Dec. 17, 2015	Dec. 16, 2016
BILOG Antenna SCHWARZBECK	VULB9168	9168-472	Jan. 07, 2016	Jan. 06, 2017
HORN Antenna SCHWARZBECK	BBHA 9120 D	9120D-969	Jan. 04, 2016	Jan. 03, 2017
HORN Antenna SCHWARZBECK	BBHA 9170	9170-480	Jan. 08, 2016	Jan. 07, 2017
Loop Antenna	EM-6879	269	Jul. 31, 2015	Jul. 30, 2016
Agilent Communications Tester-Wireless	8960 Series 10	MY53201073	Jul. 03, 2015	Jul. 02, 2017
Preamplifier EMCI	EMC 012645	980115	Dec. 21, 2015	Dec. 20, 2016
Preamplifier EMCI	EMC 184045	980116	Dec. 21, 2015	Dec. 20, 2016
Preamplifier EMCI	EMC 330H	980112	Dec. 28, 2015	Dec. 27, 2016
Power Meter Anritsu	ML2495A	1232002	Sep. 21, 2015	Sep. 20, 2016
Power Sensor Anritsu	MA2411B	1207325	Sep. 21, 2015	Sep. 20, 2016
RF signal cable HUBER+SUHNNER	SUCOFLEX 104	309219/4 2950114	Oct. 12, 2015	Oct. 11, 2016
RF signal cable HUBER+SUHNNER	SUCOFLEX 104	250130/4	Oct. 12, 2015	Oct. 11, 2016
RF Coaxial Cable Worken	8D-FB	Cable-Ch10-01	Oct. 12, 2015	Oct. 11, 2016
Software BV ADT	E3 6.120103	NA	NA	NA
Antenna Tower MF	MFA-440H	NA	NA	NA
Turn Table MF	MFT-201SS	NA	NA	NA
Antenna Tower & Turn Table Controller MF	MF-7802	NA	NA	NA

- Note: 1. The calibration interval of the above test instruments is 12 / 24 months and the calibrations are traceable to NML/ROC and NIST/USA.
2. The test was performed in HwaYa Chamber 10.
3. The horn antenna and preamplifier (model: EMC 184045) are used only for the measurement of emission frequency above 1 GHz if tested.
4. The FCC Site Registration No. is 690701.
5. The IC Site Registration No. is IC7450F-10.

4.1.4 Test Procedures

- a. The EUT was placed on the top of a rotating table 0.8 meters (for below 1 GHz) / 1.5 meters (for above 1 GHz) above the ground at 3 meter chamber room for test. The table was rotated 360 degrees to determine the position of the highest radiation.
- b. The EUT was set 3 meters away from the interference-receiving antenna, which was mounted on the top of a variable-height antenna tower.
- c. The height of antenna is varied from one meter to four meters above the ground to determine the maximum value of the field strength. Both horizontal and vertical polarizations of the antenna are set to make the measurement.
- d. For each suspected emission, the EUT was arranged to its worst case and then the antenna was tuned to heights from 1 meter to 4 meters and the rotatable table was turned from 0 degrees to 360 degrees to find the maximum reading.
- e. The test-receiver system was set to quasi-peak detect function and specified bandwidth with maximum hold mode when the test frequency is below 1 GHz.
- f. The test-receiver system was set to peak and average detected function and specified bandwidth with maximum hold mode when the test frequency is above 1 GHz. If the peak reading value also meets average limit, measurement with the average detector is unnecessary.

Note:

1. The resolution bandwidth and video bandwidth of test receiver/spectrum analyzer is 120 kHz for Quasi-peak detection (QP) at frequency below 1 GHz.
2. The resolution bandwidth of test receiver/spectrum analyzer is 1 MHz and the video bandwidth is 3 MHz for Peak detection (PK) at frequency above 1 GHz.
3. The resolution bandwidth of test receiver/spectrum analyzer is 1 MHz and the video bandwidth is 3 MHz for RMS Average (Duty cycle < 98 %) for Average detection (AV) at frequency above 1 GHz, then the measurement results was added to a correction factor ($10 \log(1/\text{duty cycle})$).
4. The resolution bandwidth of test receiver/spectrum analyzer is 1 MHz and the video bandwidth is 10 Hz (Duty cycle \geq 98 %) for Average detection (AV) at frequency above 1 GHz.
5. All modes of operation were investigated and the worst-case emissions are reported.

4.1.5 Deviation from Test Standard

No deviation.

4.1.6 Test Set Up

<Frequency Range below 1 GHz>

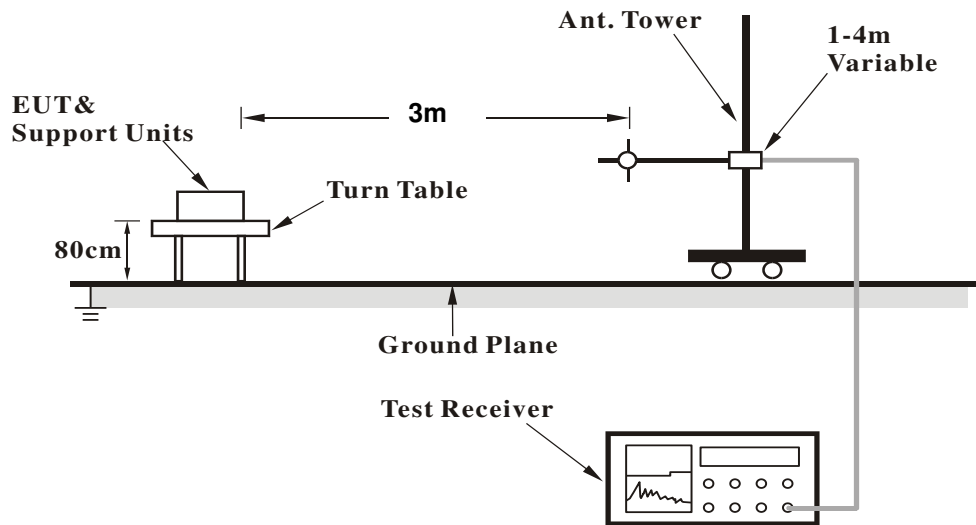

<Frequency Range above 1 GHz>

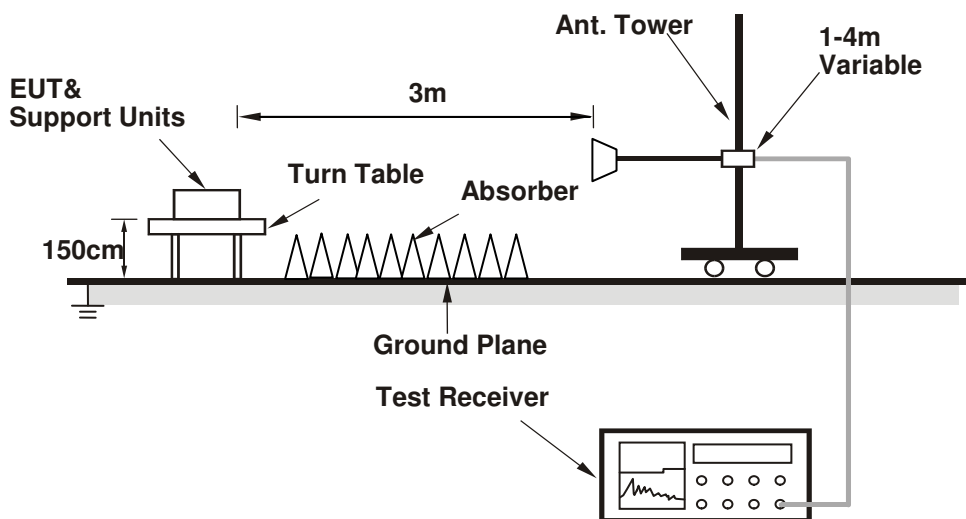

For the actual test configuration, please refer to the attached file (Test Setup Photo).

4.1.7 EUT Operating Conditions

- a. Placed the EUT on a testing table.
- b. Use the software to control the EUT under transmission condition continuously at specific channel frequency.

4.1.8 Test Results
 Above 1 GHz Data :
 MODE A (1TX)
 802.11a

EUT Test Condition		Measurement Detail	
Channel	Channel 36	Frequency Range	1 GHz ~ 40 GHz
Input Power	120 Vac, 60 Hz	Detector Function	Peak (PK) Average (AV)
Environmental Conditions	25 deg. C, 65 % RH	Tested By	Gavin Wu

Antenna Polarity & Test Distance: Horizontal at 3 m										
Frequency (MHz)	Emission Level (dBuV/m)	Read Level (dBuV)	Limit (dBuV/m)	Margin (dB)	Antenna Factor (dB/m)	Cable Loss (dB)	Preamp Factor (dB)	Antenna Height (cm)	Table Angle (Degree)	Remark
5138	39.42	39.21	54	-14.58	31.31	6.2	37.3	220	246	Average
5138	61.07	60.86	74	-12.93	31.31	6.2	37.3	220	246	Peak
5180	90.36	90.13			31.35	6.22	37.34	220	246	Average
5180	99.3	99.07			31.35	6.22	37.34	220	246	Peak
5444	40.21	39.45	54	-13.79	31.55	6.34	37.13	220	246	Average
5444	61.04	60.28	74	-12.96	31.55	6.34	37.13	220	246	Peak

Antenna Polarity & Test Distance: Vertical at 3 m										
Frequency (MHz)	Emission Level (dBuV/m)	Read Level (dBuV)	Limit (dBuV/m)	Margin (dB)	Antenna Factor (dB/m)	Cable Loss (dB)	Preamp Factor (dB)	Antenna Height (cm)	Table Angle (Degree)	Remark
5066	44.31	44.14	54	-9.69	31.25	6.17	37.25	199	293	Average
5066	60.15	59.98	74	-13.85	31.25	6.17	37.25	199	293	Peak
5180	100.21	99.98			31.35	6.22	37.34	199	293	Average
5180	109.21	108.98			31.35	6.22	37.34	199	293	Peak
5422	45.19	44.52	54	-8.81	31.53	6.32	37.18	199	293	Average
5422	60.69	60.02	74	-13.31	31.53	6.32	37.18	199	293	Peak

Remarks:

- Emission Level = Read Level + Antenna Factor + Cable Loss - Preamp Factor
 Margin value = Emission level – Limit value
- 5180 MHz: Fundamental Frequency

EUT Test Condition		Measurement Detail	
Channel	Channel 44	Frequency Range	1 GHz ~ 40 GHz
Input Power	120 Vac, 60 Hz	Detector Function	Peak (PK) Average (AV)
Environmental Conditions	25 deg. C, 65 % RH	Tested By	Gavin Wu

Antenna Polarity & Test Distance: Horizontal at 3 m										
Frequency (MHz)	Emission Level (dBuV/m)	Read Level (dBuV)	Limit (dBuV/m)	Margin (dB)	Antenna Factor (dB/m)	Cable Loss (dB)	Preamp Factor (dB)	Antenna Height (cm)	Table Angle (Degree)	Remark
5140	39.33	39.11	54	-14.67	31.32	6.2	37.3	219	255	Average
5140	61.64	61.42	74	-12.36	31.32	6.2	37.3	219	255	Peak
5220	90.4	90.15			31.37	6.24	37.36	219	255	Average
5220	99.47	99.22			31.37	6.24	37.36	219	255	Peak
5384	40.29	39.65	54	-13.71	31.51	6.31	37.18	219	255	Average
5384	60.96	60.32	74	-13.04	31.51	6.31	37.18	219	255	Peak
Antenna Polarity & Test Distance: Vertical at 3 m										
Frequency (MHz)	Emission Level (dBuV/m)	Read Level (dBuV)	Limit (dBuV/m)	Margin (dB)	Antenna Factor (dB/m)	Cable Loss (dB)	Preamp Factor (dB)	Antenna Height (cm)	Table Angle (Degree)	Remark
5036	44.01	43.87	54	-9.99	31.23	6.15	37.24	200	291	Average
5036	60.87	60.73	74	-13.13	31.23	6.15	37.24	200	291	Peak
5220	100.23	99.98			31.37	6.24	37.36	200	291	Average
5220	109.19	108.94			31.37	6.24	37.36	200	291	Peak
5422	45.63	44.96	54	-8.37	31.53	6.32	37.18	200	291	Average
5422	62.16	61.49	74	-11.84	31.53	6.32	37.18	200	291	Peak

Remarks:

- Emission Level = Read Level + Antenna Factor + Cable Loss - Preamp Factor
Margin value = Emission level – Limit value
- 5220 MHz: Fundamental Frequency

EUT Test Condition		Measurement Detail	
Channel	Channel 48	Frequency Range	1 GHz ~ 40 GHz
Input Power	120 Vac, 60 Hz	Detector Function	Peak (PK) Average (AV)
Environmental Conditions	25 deg. C, 65 % RH	Tested By	Gavin Wu

Antenna Polarity & Test Distance: Horizontal at 3 m										
Frequency (MHz)	Emission Level (dBuV/m)	Read Level (dBuV)	Limit (dBuV/m)	Margin (dB)	Antenna Factor (dB/m)	Cable Loss (dB)	Preamp Factor (dB)	Antenna Height (cm)	Table Angle (Degree)	Remark
5042	39.1	38.96	54	-14.9	31.24	6.15	37.25	220	253	Average
5042	60.25	60.11	74	-13.75	31.24	6.15	37.25	220	253	Peak
5240	90.38	90.06			31.39	6.25	37.32	220	253	Average
5240	99.39	99.07			31.39	6.25	37.32	220	253	Peak
5438	40.4	39.64	54	-13.6	31.55	6.34	37.13	220	253	Average
5438	61.59	60.83	74	-12.41	31.55	6.34	37.13	220	253	Peak
Antenna Polarity & Test Distance: Vertical at 3 m										
Frequency (MHz)	Emission Level (dBuV/m)	Read Level (dBuV)	Limit (dBuV/m)	Margin (dB)	Antenna Factor (dB/m)	Cable Loss (dB)	Preamp Factor (dB)	Antenna Height (cm)	Table Angle (Degree)	Remark
5084	45.73	45.56	54	-8.27	31.27	6.17	37.27	194	287	Average
5084	61.32	61.15	74	-12.68	31.27	6.17	37.27	194	287	Peak
5240	100.45	100.13			31.39	6.25	37.32	194	287	Average
5240	109.57	109.25			31.39	6.25	37.32	194	287	Peak
5392	46.9	46.26	54	-7.1	31.51	6.31	37.18	194	287	Average
5392	61.95	61.31	74	-12.05	31.51	6.31	37.18	194	287	Peak

Remarks:

- Emission Level = Read Level + Antenna Factor + Cable Loss - Preamp Factor
Margin value = Emission level – Limit value
- 5240 MHz: Fundamental Frequency

EUT Test Condition		Measurement Detail	
Channel	Channel 52	Frequency Range	1 GHz ~ 40 GHz
Input Power	120 Vac, 60 Hz	Detector Function	Peak (PK) Average (AV)
Environmental Conditions	25 deg. C, 65 % RH	Tested By	Gavin Wu

Antenna Polarity & Test Distance: Horizontal at 3 m										
Frequency (MHz)	Emission Level (dBuV/m)	Read Level (dBuV)	Limit (dBuV/m)	Margin (dB)	Antenna Factor (dB/m)	Cable Loss (dB)	Preamp Factor (dB)	Antenna Height (cm)	Table Angle (Degree)	Remark
5060	38.08	37.91	54	-15.92	31.25	6.17	37.25	100	65	Average
5060	61.08	60.91	74	-12.92	31.25	6.17	37.25	100	65	Peak
5260	87.69	87.3			31.41	6.25	37.27	100	65	Average
5260	97.33	96.94			31.41	6.25	37.27	100	65	Peak
5458	38.97	38.15	54	-15.03	31.56	6.34	37.08	100	65	Average
5458	61.11	60.29	74	-12.89	31.56	6.34	37.08	100	65	Peak
Antenna Polarity & Test Distance: Vertical at 3 m										
Frequency (MHz)	Emission Level (dBuV/m)	Read Level (dBuV)	Limit (dBuV/m)	Margin (dB)	Antenna Factor (dB/m)	Cable Loss (dB)	Preamp Factor (dB)	Antenna Height (cm)	Table Angle (Degree)	Remark
5090	43.95	43.75	54	-10.05	31.28	6.19	37.27	200	202	Average
5090	61.17	60.97	74	-12.83	31.28	6.19	37.27	200	202	Peak
5260	98.87	98.48			31.41	6.25	37.27	200	202	Average
5260	108.18	107.79			31.41	6.25	37.27	200	202	Peak
5454	44.04	43.22	54	-9.96	31.56	6.34	37.08	200	202	Average
5454	62.03	61.21	74	-11.97	31.56	6.34	37.08	200	202	Peak

Remarks:

- Emission Level = Read Level + Antenna Factor + Cable Loss - Preamp Factor
Margin value = Emission level – Limit value
- 5260 MHz: Fundamental Frequency

EUT Test Condition		Measurement Detail	
Channel	Channel 60	Frequency Range	1 GHz ~ 40 GHz
Input Power	120 Vac, 60 Hz	Detector Function	Peak (PK) Average (AV)
Environmental Conditions	25 deg. C, 65 % RH	Tested By	Gavin Wu

Antenna Polarity & Test Distance: Horizontal at 3 m										
Frequency (MHz)	Emission Level (dBuV/m)	Read Level (dBuV)	Limit (dBuV/m)	Margin (dB)	Antenna Factor (dB/m)	Cable Loss (dB)	Preamp Factor (dB)	Antenna Height (cm)	Table Angle (Degree)	Remark
5080	38.02	37.85	54	-15.98	31.27	6.17	37.27	112	61	Average
5080	60.39	60.22	74	-13.61	31.27	6.17	37.27	112	61	Peak
5300	88.41	87.89			31.44	6.27	37.19	112	61	Average
5300	98.14	97.62			31.44	6.27	37.19	112	61	Peak
5432	39.18	38.44	54	-14.82	31.55	6.32	37.13	112	61	Average
5432	60.83	60.09	74	-13.17	31.55	6.32	37.13	112	61	Peak
Antenna Polarity & Test Distance: Vertical at 3 m										
Frequency (MHz)	Emission Level (dBuV/m)	Read Level (dBuV)	Limit (dBuV/m)	Margin (dB)	Antenna Factor (dB/m)	Cable Loss (dB)	Preamp Factor (dB)	Antenna Height (cm)	Table Angle (Degree)	Remark
5118	44.25	44.05	54	-9.75	31.29	6.19	37.28	200	201	Average
5118	61.34	61.14	74	-12.66	31.29	6.19	37.28	200	201	Peak
5300	98.99	98.47			31.44	6.27	37.19	200	201	Average
5300	108.33	107.81			31.44	6.27	37.19	200	201	Peak
5368	43.51	42.89	54	-10.49	31.49	6.31	37.18	200	201	Average
5368	61.76	61.14	74	-12.24	31.49	6.31	37.18	200	201	Peak

Remarks:

- Emission Level = Read Level + Antenna Factor + Cable Loss - Preamp Factor
Margin value = Emission level – Limit value
- 5300 MHz: Fundamental Frequency

EUT Test Condition		Measurement Detail	
Channel	Channel 64	Frequency Range	1 GHz ~ 40 GHz
Input Power	120 Vac, 60 Hz	Detector Function	Peak (PK) Average (AV)
Environmental Conditions	25 deg. C, 65 % RH	Tested By	Gavin Wu

Antenna Polarity & Test Distance: Horizontal at 3 m										
Frequency (MHz)	Emission Level (dBuV/m)	Read Level (dBuV)	Limit (dBuV/m)	Margin (dB)	Antenna Factor (dB/m)	Cable Loss (dB)	Preamp Factor (dB)	Antenna Height (cm)	Table Angle (Degree)	Remark
5138	38.15	37.94	54	-15.85	31.31	6.2	37.3	112	61	Average
5138	60.43	60.22	74	-13.57	31.31	6.2	37.3	112	61	Peak
5320	89.14	88.59			31.45	6.29	37.19	112	61	Average
5320	98.54	97.99			31.45	6.29	37.19	112	61	Peak
5432	39.22	38.48	54	-14.78	31.55	6.32	37.13	112	61	Average
5432	61.28	60.54	74	-12.72	31.55	6.32	37.13	112	61	Peak

Antenna Polarity & Test Distance: Vertical at 3 m										
Frequency (MHz)	Emission Level (dBuV/m)	Read Level (dBuV)	Limit (dBuV/m)	Margin (dB)	Antenna Factor (dB/m)	Cable Loss (dB)	Preamp Factor (dB)	Antenna Height (cm)	Table Angle (Degree)	Remark
5144	43.81	43.61	54	-10.19	31.32	6.2	37.32	200	208	Average
5144	62.81	62.61	74	-11.19	31.32	6.2	37.32	200	208	Peak
5320	98.13	97.58			31.45	6.29	37.19	200	208	Average
5320	107.41	106.86			31.45	6.29	37.19	200	208	Peak
5434	44.37	43.63	54	-9.63	31.55	6.32	37.13	200	208	Average
5434	61.61	60.87	74	-12.39	31.55	6.32	37.13	200	208	Peak

Remarks:

- Emission Level = Read Level + Antenna Factor + Cable Loss - Preamp Factor
Margin value = Emission level – Limit value
- 5320 MHz: Fundamental Frequency

EUT Test Condition		Measurement Detail	
Channel	Channel 100	Frequency Range	1 GHz ~ 40 GHz
Input Power	120 Vac, 60 Hz	Detector Function	Peak (PK) Average (AV)
Environmental Conditions	25 deg. C, 65 % RH	Tested By	Gavin Wu

Antenna Polarity & Test Distance: Horizontal at 3 m										
Frequency (MHz)	Emission Level (dBuV/m)	Read Level (dBuV)	Limit (dBuV/m)	Margin (dB)	Antenna Factor (dB/m)	Cable Loss (dB)	Preamp Factor (dB)	Antenna Height (cm)	Table Angle (Degree)	Remark
5370	39.07	38.45	54	-14.93	31.49	6.31	37.18	151	173	Average
5370	59.91	59.29	74	-14.09	31.49	6.31	37.18	151	173	Peak
5470	59.49	58.66	68.2	-8.71	31.57	6.34	37.08	151	173	Peak
5500	88.35	87.42			31.6	6.36	37.03	151	173	Average
5500	97.89	96.96			31.6	6.36	37.03	151	173	Peak
5725	59.02	57.74	68.2	-9.18	31.96	6.75	37.43	151	173	Peak
Antenna Polarity & Test Distance: Vertical at 3 m										
Frequency (MHz)	Emission Level (dBuV/m)	Read Level (dBuV)	Limit (dBuV/m)	Margin (dB)	Antenna Factor (dB/m)	Cable Loss (dB)	Preamp Factor (dB)	Antenna Height (cm)	Table Angle (Degree)	Remark
5448	42.56	41.79	54	-11.44	31.56	6.34	37.13	199	214	Average
5448	60.1	59.33	74	-13.9	31.56	6.34	37.13	199	214	Peak
5470	59.31	58.48	68.2	-8.89	31.57	6.34	37.08	199	214	Peak
5500	97.31	96.39			31.59	6.36	37.03	199	214	Average
5500	107.06	106.14			31.59	6.36	37.03	199	214	Peak
5725	59.3	58.02	68.2	-8.9	31.96	6.75	37.43	199	214	Peak

Remarks:

- Emission Level = Read Level + Antenna Factor + Cable Loss - Preamp Factor
Margin value = Emission level – Limit value
- 5500 MHz: Fundamental Frequency
- 5470 MHz & 5725 MHz: Out of Restricted Band

EUT Test Condition		Measurement Detail	
Channel	Channel 116	Frequency Range	1 GHz ~ 40 GHz
Input Power	120 Vac, 60 Hz	Detector Function	Peak (PK) Average (AV)
Environmental Conditions	25 deg. C, 65 % RH	Tested By	Gavin Wu

Antenna Polarity & Test Distance: Horizontal at 3 m										
Frequency (MHz)	Emission Level (dBuV/m)	Read Level (dBuV)	Limit (dBuV/m)	Margin (dB)	Antenna Factor (dB/m)	Cable Loss (dB)	Preamp Factor (dB)	Antenna Height (cm)	Table Angle (Degree)	Remark
5422	39.98	39.31	54	-14.02	31.53	6.32	37.18	151	170	Average
5422	61.16	60.49	74	-12.84	31.53	6.32	37.18	151	170	Peak
5470	58.99	58.16	68.2	-9.21	31.57	6.34	37.08	151	170	Peak
5580	88.11	87.07			31.71	6.49	37.16	151	170	Average
5580	98.53	97.49			31.71	6.49	37.16	151	170	Peak
5725	60.12	58.84	68.2	-8.08	31.96	6.75	37.43	151	170	Peak
Antenna Polarity & Test Distance: Vertical at 3 m										
Frequency (MHz)	Emission Level (dBuV/m)	Read Level (dBuV)	Limit (dBuV/m)	Margin (dB)	Antenna Factor (dB/m)	Cable Loss (dB)	Preamp Factor (dB)	Antenna Height (cm)	Table Angle (Degree)	Remark
5376	46.5	45.88	54	-7.5	31.49	6.31	37.18	180	207	Average
5376	61.7	61.08	74	-12.3	31.49	6.31	37.18	180	207	Peak
5470	60.87	60.04	68.2	-7.33	31.57	6.34	37.08	180	207	Peak
5580	96.9	95.86			31.71	6.49	37.16	180	207	Average
5580	106.89	105.85			31.71	6.49	37.16	180	207	Peak
5725	59.94	58.66	68.2	-8.26	31.96	6.75	37.43	180	207	Peak

Remarks:

- Emission Level = Read Level + Antenna Factor + Cable Loss - Preamp Factor
Margin value = Emission level – Limit value
- 5580 MHz: Fundamental Frequency
- 5470 MHz & 5725 MHz: Out of Restricted Band

EUT Test Condition		Measurement Detail	
Channel	Channel 140	Frequency Range	1 GHz ~ 40 GHz
Input Power	120 Vac, 60 Hz	Detector Function	Peak (PK) Average (AV)
Environmental Conditions	25 deg. C, 65 % RH	Tested By	Gavin Wu

Antenna Polarity & Test Distance: Horizontal at 3 m										
Frequency (MHz)	Emission Level (dBuV/m)	Read Level (dBuV)	Limit (dBuV/m)	Margin (dB)	Antenna Factor (dB/m)	Cable Loss (dB)	Preamp Factor (dB)	Antenna Height (cm)	Table Angle (Degree)	Remark
5376	39.94	39.32	54	-14.06	31.49	6.31	37.18	124	170	Average
5376	61.4	60.78	74	-12.6	31.49	6.31	37.18	124	170	Peak
5470	59.2	58.37	68.2	-9	31.57	6.34	37.08	124	170	Peak
5700	88.54	87.35			31.9	6.69	37.4	124	170	Average
5700	98.45	97.26			31.9	6.69	37.4	124	170	Peak
5725	59.85	58.57	68.2	-8.35	31.96	6.75	37.43	124	170	Peak
Antenna Polarity & Test Distance: Vertical at 3 m										
Frequency (MHz)	Emission Level (dBuV/m)	Read Level (dBuV)	Limit (dBuV/m)	Margin (dB)	Antenna Factor (dB/m)	Cable Loss (dB)	Preamp Factor (dB)	Antenna Height (cm)	Table Angle (Degree)	Remark
5414	46.03	45.36	54	-7.97	31.53	6.32	37.18	167	209	Average
5414	62.72	62.05	74	-11.28	31.53	6.32	37.18	167	209	Peak
5470	61.12	60.29	68.2	-7.08	31.57	6.34	37.08	167	209	Peak
5700	98.1	96.91			31.9	6.69	37.4	167	209	Average
5700	108.16	106.97			31.9	6.69	37.4	167	209	Peak
5725	63.85	62.57	68.2	-4.35	31.96	6.75	37.43	167	209	Peak

Remarks:

- Emission Level = Read Level + Antenna Factor + Cable Loss - Preamp Factor
Margin value = Emission level – Limit value
- 5700 MHz: Fundamental Frequency
- 5470 MHz & 5725 MHz: Out of Restricted Band

EUT Test Condition		Measurement Detail	
Channel	Channel 149	Frequency Range	1 GHz ~ 40 GHz
Input Power	120 Vac, 60 Hz	Detector Function	Peak (PK) Average (AV)
Environmental Conditions	25 deg. C, 65 % RH	Tested By	Gavin Wu

Antenna Polarity & Test Distance: Horizontal at 3 m										
Frequency (MHz)	Emission Level (dBuV/m)	Read Level (dBuV)	Limit (dBuV/m)	Margin (dB)	Antenna Factor (dB/m)	Cable Loss (dB)	Preamp Factor (dB)	Antenna Height (cm)	Table Angle (Degree)	Remark
*5714	60.73	59.54	68.2	-7.47	31.93	6.69	37.43	212	255	Peak
*5725	62.66	61.38	78.2	-15.54	31.96	6.75	37.43	212	255	Peak
5745	91.2	89.93			31.99	6.75	37.47	212	255	Average
5745	100.36	99.09			31.99	6.75	37.47	212	255	Peak
*5850	58.3	56.78	78.2	-19.9	32.15	6.88	37.51	212	255	Peak
*5861	60.06	58.43	68.2	-8.14	32.18	6.95	37.5	212	255	Peak
Antenna Polarity & Test Distance: Vertical at 3 m										
Frequency (MHz)	Emission Level (dBuV/m)	Read Level (dBuV)	Limit (dBuV/m)	Margin (dB)	Antenna Factor (dB/m)	Cable Loss (dB)	Preamp Factor (dB)	Antenna Height (cm)	Table Angle (Degree)	Remark
*5714	60.89	59.7	68.2	-7.31	31.93	6.69	37.43	202	282	Peak
*5725	74.14	72.86	78.2	-4.06	31.96	6.75	37.43	202	282	Peak
5745	100.75	99.48			31.99	6.75	37.47	202	282	Average
5745	110.37	109.1			31.99	6.75	37.47	202	282	Peak
*5850	60.74	59.22	78.2	-17.46	32.15	6.88	37.51	202	282	Peak
*5861	59.59	57.96	68.2	-8.61	32.18	6.95	37.5	202	282	Peak

Remarks:

- Emission Level = Read Level + Antenna Factor + Cable Loss - Preamp Factor
Margin value = Emission level – Limit value
- 5745 MHz: Fundamental Frequency
- *: Out of Restricted Band

EUT Test Condition		Measurement Detail	
Channel	Channel 157	Frequency Range	1 GHz ~ 40 GHz
Input Power	120 Vac, 60 Hz	Detector Function	Peak (PK) Average (AV)
Environmental Conditions	25 deg. C, 65 % RH	Tested By	Gavin Wu

Antenna Polarity & Test Distance: Horizontal at 3 m										
Frequency (MHz)	Emission Level (dBuV/m)	Read Level (dBuV)	Limit (dBuV/m)	Margin (dB)	Antenna Factor (dB/m)	Cable Loss (dB)	Preamp Factor (dB)	Antenna Height (cm)	Table Angle (Degree)	Remark
*5714	59.46	58.27	68.2	-8.74	31.93	6.69	37.43	210	256	Peak
*5725	59.25	57.97	78.2	-18.95	31.96	6.75	37.43	210	256	Peak
5785	91.16	89.84			32.04	6.82	37.54	210	256	Average
5785	100.28	98.96			32.04	6.82	37.54	210	256	Peak
*5850	60.5	58.98	78.2	-17.7	32.15	6.88	37.51	210	256	Peak
*5861	59.87	58.24	68.2	-8.33	32.18	6.95	37.5	210	256	Peak
Antenna Polarity & Test Distance: Vertical at 3 m										
Frequency (MHz)	Emission Level (dBuV/m)	Read Level (dBuV)	Limit (dBuV/m)	Margin (dB)	Antenna Factor (dB/m)	Cable Loss (dB)	Preamp Factor (dB)	Antenna Height (cm)	Table Angle (Degree)	Remark
*5714	60.59	59.4	68.2	-7.61	31.93	6.69	37.43	198	289	Peak
*5725	60.2	58.92	78.2	-18	31.96	6.75	37.43	198	289	Peak
5785	100.98	99.66			32.04	6.82	37.54	198	289	Average
5785	110.24	108.92			32.04	6.82	37.54	198	289	Peak
*5850	59.52	58	78.2	-18.68	32.15	6.88	37.51	198	289	Peak
*5861	60.95	59.32	68.2	-7.25	32.18	6.95	37.5	198	289	Peak

Remarks:

- Emission Level = Read Level + Antenna Factor + Cable Loss - Preamp Factor
Margin value = Emission level – Limit value
- 5785 MHz: Fundamental Frequency
- *: Out of Restricted Band

EUT Test Condition		Measurement Detail	
Channel	Channel 165	Frequency Range	1 GHz ~ 40 GHz
Input Power	120 Vac, 60 Hz	Detector Function	Peak (PK) Average (AV)
Environmental Conditions	25 deg. C, 65 % RH	Tested By	Gavin Wu

Antenna Polarity & Test Distance: Horizontal at 3 m										
Frequency (MHz)	Emission Level (dBuV/m)	Read Level (dBuV)	Limit (dBuV/m)	Margin (dB)	Antenna Factor (dB/m)	Cable Loss (dB)	Preamp Factor (dB)	Antenna Height (cm)	Table Angle (Degree)	Remark
*5714	60.26	59.07	68.2	-7.94	31.93	6.69	37.43	215	262	Peak
*5725	59.02	57.74	78.2	-19.18	31.96	6.75	37.43	215	262	Peak
5825	91.25	89.78			32.12	6.88	37.53	215	262	Average
5825	100.22	98.75			32.12	6.88	37.53	215	262	Peak
*5850	59.93	58.41	78.2	-18.27	32.15	6.88	37.51	215	262	Peak
*5861	59.38	57.75	68.2	-8.82	32.18	6.95	37.5	215	262	Peak
Antenna Polarity & Test Distance: Vertical at 3 m										
Frequency (MHz)	Emission Level (dBuV/m)	Read Level (dBuV)	Limit (dBuV/m)	Margin (dB)	Antenna Factor (dB/m)	Cable Loss (dB)	Preamp Factor (dB)	Antenna Height (cm)	Table Angle (Degree)	Remark
*5714	61.85	60.66	68.2	-6.35	31.93	6.69	37.43	204	284	Peak
*5725	62.78	61.5	78.2	-15.42	31.96	6.75	37.43	204	284	Peak
5825	100.96	99.49			32.12	6.88	37.53	204	284	Average
5825	110.02	108.55			32.12	6.88	37.53	204	284	Peak
*5850	60.92	59.4	78.2	-17.28	32.15	6.88	37.51	204	284	Peak
*5861	60.86	59.23	68.2	-7.34	32.18	6.95	37.5	204	284	Peak

Remarks:

- Emission Level = Read Level + Antenna Factor + Cable Loss - Preamp Factor
Margin value = Emission level – Limit value
- 5825 MHz: Fundamental Frequency
- *: Out of Restricted Band

MODE B (3TX)
802.11n (HT20)

EUT Test Condition		Measurement Detail	
Channel	Channel 36	Frequency Range	1 GHz ~ 40 GHz
Input Power	120 Vac, 60 Hz	Detector Function	Peak (PK) Average (AV)
Environmental Conditions	25 deg. C, 65 % RH	Tested By	Gavin Wu

Antenna Polarity & Test Distance: Horizontal at 3 m										
Frequency (MHz)	Emission Level (dBuV/m)	Read Level (dBuV)	Limit (dBuV/m)	Margin (dB)	Antenna Factor (dB/m)	Cable Loss (dB)	Preamp Factor (dB)	Antenna Height (cm)	Table Angle (Degree)	Remark
5014	41.09	40.96	54	-12.91	31.21	6.15	37.23	217	249	Average
5014	60.37	60.24	74	-13.63	31.21	6.15	37.23	217	249	Peak
5180	95.29	95.06			31.35	6.22	37.34	217	249	Average
5180	104.77	104.54			31.35	6.22	37.34	217	249	Peak
5370	40.57	39.95	54	-13.43	31.49	6.31	37.18	217	249	Average
5370	60.47	59.85	74	-13.53	31.49	6.31	37.18	217	249	Peak

Antenna Polarity & Test Distance: Vertical at 3 m										
Frequency (MHz)	Emission Level (dBuV/m)	Read Level (dBuV)	Limit (dBuV/m)	Margin (dB)	Antenna Factor (dB/m)	Cable Loss (dB)	Preamp Factor (dB)	Antenna Height (cm)	Table Angle (Degree)	Remark
5150	51.29	51.09	54	-2.71	31.32	6.2	37.32	210	281	Average
5150	63.47	63.27	74	-10.53	31.32	6.2	37.32	210	281	Peak
5180	107.83	107.6			31.35	6.22	37.34	210	281	Average
5180	115.2	114.97			31.35	6.22	37.34	210	281	Peak
5352	50.43	49.84	54	-3.57	31.48	6.29	37.18	210	281	Average
5352	63.89	63.3	74	-10.11	31.48	6.29	37.18	210	281	Peak

Remarks:

- Emission Level = Read Level + Antenna Factor + Cable Loss - Preamp Factor
 Margin value = Emission level – Limit value
- 5180 MHz: Fundamental Frequency

EUT Test Condition		Measurement Detail	
Channel	Channel 44	Frequency Range	1 GHz ~ 40 GHz
Input Power	120 Vac, 60 Hz	Detector Function	Peak (PK) Average (AV)
Environmental Conditions	25 deg. C, 65 % RH	Tested By	Gavin Wu

Antenna Polarity & Test Distance: Horizontal at 3 m										
Frequency (MHz)	Emission Level (dBuV/m)	Read Level (dBuV)	Limit (dBuV/m)	Margin (dB)	Antenna Factor (dB/m)	Cable Loss (dB)	Preamp Factor (dB)	Antenna Height (cm)	Table Angle (Degree)	Remark
5130	40.6	40.39	54	-13.4	31.31	6.2	37.3	216	246	Average
5130	61.23	61.02	74	-12.77	31.31	6.2	37.3	216	246	Peak
5220	95.54	95.29			31.37	6.24	37.36	216	246	Average
5220	104.94	104.69			31.37	6.24	37.36	216	246	Peak
5424	41.72	41.05	54	-12.28	31.53	6.32	37.18	216	246	Average
5424	61.02	60.35	74	-12.98	31.53	6.32	37.18	216	246	Peak
Antenna Polarity & Test Distance: Vertical at 3 m										
Frequency (MHz)	Emission Level (dBuV/m)	Read Level (dBuV)	Limit (dBuV/m)	Margin (dB)	Antenna Factor (dB/m)	Cable Loss (dB)	Preamp Factor (dB)	Antenna Height (cm)	Table Angle (Degree)	Remark
5126	50.31	50.1	54	-3.69	31.31	6.2	37.3	211	283	Average
5126	64.24	64.03	74	-9.76	31.31	6.2	37.3	211	283	Peak
5220	107.83	107.58			31.37	6.24	37.36	211	283	Average
5220	115.19	114.94			31.37	6.24	37.36	211	283	Peak
5366	50.63	50.01	54	-3.37	31.49	6.31	37.18	211	283	Average
5366	63.98	63.36	74	-10.02	31.49	6.31	37.18	211	283	Peak

Remarks:

- Emission Level = Read Level + Antenna Factor + Cable Loss - Preamp Factor
Margin value = Emission level – Limit value
- 5220 MHz: Fundamental Frequency

EUT Test Condition		Measurement Detail	
Channel	Channel 48	Frequency Range	1 GHz ~ 40 GHz
Input Power	120 Vac, 60 Hz	Detector Function	Peak (PK) Average (AV)
Environmental Conditions	25 deg. C, 65 % RH	Tested By	Gavin Wu

Antenna Polarity & Test Distance: Horizontal at 3 m										
Frequency (MHz)	Emission Level (dBuV/m)	Read Level (dBuV)	Limit (dBuV/m)	Margin (dB)	Antenna Factor (dB/m)	Cable Loss (dB)	Preamp Factor (dB)	Antenna Height (cm)	Table Angle (Degree)	Remark
5130	40.58	40.37	54	-13.42	31.31	6.2	37.3	219	242	Average
5130	60.19	59.98	74	-13.81	31.31	6.2	37.3	219	242	Peak
5240	95.73	95.41			31.39	6.25	37.32	219	242	Average
5240	105.08	104.76			31.39	6.25	37.32	219	242	Peak
5378	41.43	40.79	54	-12.57	31.51	6.31	37.18	219	242	Average
5378	60.96	60.32	74	-13.04	31.51	6.31	37.18	219	242	Peak
Antenna Polarity & Test Distance: Vertical at 3 m										
Frequency (MHz)	Emission Level (dBuV/m)	Read Level (dBuV)	Limit (dBuV/m)	Margin (dB)	Antenna Factor (dB/m)	Cable Loss (dB)	Preamp Factor (dB)	Antenna Height (cm)	Table Angle (Degree)	Remark
5106	49.95	49.75	54	-4.05	31.29	6.19	37.28	209	295	Average
5106	63.6	63.4	74	-10.4	31.29	6.19	37.28	209	295	Peak
5240	107.97	107.65			31.39	6.25	37.32	209	295	Average
5240	115.33	115.01			31.39	6.25	37.32	209	295	Peak
5420	49.98	49.31	54	-4.02	31.53	6.32	37.18	209	295	Average
5420	64.03	63.36	74	-9.97	31.53	6.32	37.18	209	295	Peak

Remarks:

- Emission Level = Read Level + Antenna Factor + Cable Loss - Preamp Factor
Margin value = Emission level – Limit value
- 5240 MHz: Fundamental Frequency

EUT Test Condition		Measurement Detail	
Channel	Channel 52	Frequency Range	1 GHz ~ 40 GHz
Input Power	120 Vac, 60 Hz	Detector Function	Peak (PK) Average (AV)
Environmental Conditions	25 deg. C, 65 % RH	Tested By	Gavin Wu

Antenna Polarity & Test Distance: Horizontal at 3 m										
Frequency (MHz)	Emission Level (dBuV/m)	Read Level (dBuV)	Limit (dBuV/m)	Margin (dB)	Antenna Factor (dB/m)	Cable Loss (dB)	Preamp Factor (dB)	Antenna Height (cm)	Table Angle (Degree)	Remark
5148	46.5	46.3	54	-7.5	31.32	6.2	37.32	146	27	Average
5148	61.76	61.56	74	-12.24	31.32	6.2	37.32	146	27	Peak
5260	100.39	100			31.41	6.25	37.27	146	27	Average
5260	109.8	109.41			31.41	6.25	37.27	146	27	Peak
5456	43.94	43.12	54	-10.06	31.56	6.34	37.08	146	27	Average
5456	61.24	60.42	74	-12.76	31.56	6.34	37.08	146	27	Peak
Antenna Polarity & Test Distance: Vertical at 3 m										
Frequency (MHz)	Emission Level (dBuV/m)	Read Level (dBuV)	Limit (dBuV/m)	Margin (dB)	Antenna Factor (dB/m)	Cable Loss (dB)	Preamp Factor (dB)	Antenna Height (cm)	Table Angle (Degree)	Remark
5096	45.61	45.42	54	-8.39	31.28	6.19	37.28	200	287	Average
5096	62.18	61.99	74	-11.82	31.28	6.19	37.28	200	287	Peak
5260	103.34	102.95			31.41	6.25	37.27	200	287	Average
5260	112.6	112.21			31.41	6.25	37.27	200	287	Peak
5362	46.21	45.59	54	-7.79	31.49	6.31	37.18	200	287	Average
5362	62.54	61.92	74	-11.46	31.49	6.31	37.18	200	287	Peak

Remarks:

- Emission Level = Read Level + Antenna Factor + Cable Loss - Preamp Factor
Margin value = Emission level – Limit value
- 5260 MHz: Fundamental Frequency

EUT Test Condition		Measurement Detail	
Channel	Channel 60	Frequency Range	1 GHz ~ 40 GHz
Input Power	120 Vac, 60 Hz	Detector Function	Peak (PK) Average (AV)
Environmental Conditions	25 deg. C, 65 % RH	Tested By	Gavin Wu

Antenna Polarity & Test Distance: Horizontal at 3 m										
Frequency (MHz)	Emission Level (dBuV/m)	Read Level (dBuV)	Limit (dBuV/m)	Margin (dB)	Antenna Factor (dB/m)	Cable Loss (dB)	Preamp Factor (dB)	Antenna Height (cm)	Table Angle (Degree)	Remark
5116	44.09	43.89	54	-9.91	31.29	6.19	37.28	135	28	Average
5116	61	60.8	74	-13	31.29	6.19	37.28	135	28	Peak
5300	99.41	98.89			31.44	6.27	37.19	135	28	Average
5300	109	108.48			31.44	6.27	37.19	135	28	Peak
5374	45.5	44.88	54	-8.5	31.49	6.31	37.18	135	28	Average
5374	61.39	60.77	74	-12.61	31.49	6.31	37.18	135	28	Peak
Antenna Polarity & Test Distance: Vertical at 3 m										
Frequency (MHz)	Emission Level (dBuV/m)	Read Level (dBuV)	Limit (dBuV/m)	Margin (dB)	Antenna Factor (dB/m)	Cable Loss (dB)	Preamp Factor (dB)	Antenna Height (cm)	Table Angle (Degree)	Remark
5094	45.71	45.52	54	-8.29	31.28	6.19	37.28	200	255	Average
5094	61.24	61.05	74	-12.76	31.28	6.19	37.28	200	255	Peak
5300	103.21	102.69			31.44	6.27	37.19	200	255	Average
5300	112.11	111.59			31.44	6.27	37.19	200	255	Peak
5416	44.95	44.28	54	-9.05	31.53	6.32	37.18	200	255	Average
5416	61.26	60.59	74	-12.74	31.53	6.32	37.18	200	255	Peak

Remarks:

- Emission Level = Read Level + Antenna Factor + Cable Loss - Preamp Factor
Margin value = Emission level – Limit value
- 5300 MHz: Fundamental Frequency

EUT Test Condition		Measurement Detail	
Channel	Channel 64	Frequency Range	1 GHz ~ 40 GHz
Input Power	120 Vac, 60 Hz	Detector Function	Peak (PK) Average (AV)
Environmental Conditions	25 deg. C, 65 % RH	Tested By	Gavin Wu

Antenna Polarity & Test Distance: Horizontal at 3 m										
Frequency (MHz)	Emission Level (dBuV/m)	Read Level (dBuV)	Limit (dBuV/m)	Margin (dB)	Antenna Factor (dB/m)	Cable Loss (dB)	Preamp Factor (dB)	Antenna Height (cm)	Table Angle (Degree)	Remark
5120	45.12	44.94	54	-8.88	31.29	6.19	37.3	135	28	Average
5120	61.23	61.05	74	-12.77	31.29	6.19	37.3	135	28	Peak
5320	99.59	99.04			31.45	6.29	37.19	135	28	Average
5320	109.23	108.68			31.45	6.29	37.19	135	28	Peak
5448	45	44.23	54	-9	31.56	6.34	37.13	135	28	Average
5448	61.38	60.61	74	-12.62	31.56	6.34	37.13	135	28	Peak
Antenna Polarity & Test Distance: Vertical at 3 m										
Frequency (MHz)	Emission Level (dBuV/m)	Read Level (dBuV)	Limit (dBuV/m)	Margin (dB)	Antenna Factor (dB/m)	Cable Loss (dB)	Preamp Factor (dB)	Antenna Height (cm)	Table Angle (Degree)	Remark
5116	45.93	45.73	54	-8.07	31.29	6.19	37.28	202	287	Average
5116	61.98	61.78	74	-12.02	31.29	6.19	37.28	202	287	Peak
5320	103.72	103.17			31.45	6.29	37.19	202	287	Average
5320	112.38	111.83			31.45	6.29	37.19	202	287	Peak
5432	45.76	45.02	54	-8.24	31.55	6.32	37.13	202	287	Average
5432	61.73	60.99	74	-12.27	31.55	6.32	37.13	202	287	Peak

Remarks:

- Emission Level = Read Level + Antenna Factor + Cable Loss - Preamp Factor
Margin value = Emission level – Limit value
- 5320 MHz: Fundamental Frequency

EUT Test Condition		Measurement Detail	
Channel	Channel 100	Frequency Range	1 GHz ~ 40 GHz
Input Power	120 Vac, 60 Hz	Detector Function	Peak (PK) Average (AV)
Environmental Conditions	25 deg. C, 65 % RH	Tested By	Gavin Wu

Antenna Polarity & Test Distance: Horizontal at 3 m										
Frequency (MHz)	Emission Level (dBuV/m)	Read Level (dBuV)	Limit (dBuV/m)	Margin (dB)	Antenna Factor (dB/m)	Cable Loss (dB)	Preamp Factor (dB)	Antenna Height (cm)	Table Angle (Degree)	Remark
5404	42.33	41.67	54	-11.67	31.52	6.32	37.18	100	66	Average
5404	60.35	59.69	74	-13.65	31.52	6.32	37.18	100	66	Peak
5470	59.17	58.34	68.2	-9.03	31.57	6.34	37.08	100	66	Peak
5500	96.9	95.97			31.6	6.36	37.03	100	66	Average
5500	106.57	105.64			31.6	6.36	37.03	100	66	Peak
5725	59.79	58.51	68.2	-8.41	31.96	6.75	37.43	100	66	Peak
Antenna Polarity & Test Distance: Vertical at 3 m										
Frequency (MHz)	Emission Level (dBuV/m)	Read Level (dBuV)	Limit (dBuV/m)	Margin (dB)	Antenna Factor (dB/m)	Cable Loss (dB)	Preamp Factor (dB)	Antenna Height (cm)	Table Angle (Degree)	Remark
5370	48.23	47.61	54	-5.77	31.49	6.31	37.18	201	284	Average
5370	62.45	61.83	74	-11.55	31.49	6.31	37.18	201	284	Peak
5470	61.05	60.22	68.2	-7.15	31.57	6.34	37.08	201	284	Peak
5500	102.59	101.66			31.6	6.36	37.03	201	284	Average
5500	112.39	111.46			31.6	6.36	37.03	201	284	Peak
5725	60.48	59.2	68.2	-7.72	31.96	6.75	37.43	201	284	Peak

Remarks:

- Emission Level = Read Level + Antenna Factor + Cable Loss - Preamp Factor
Margin value = Emission level – Limit value
- 5500 MHz: Fundamental Frequency
- 5470 MHz & 5725 MHz: Out of Restricted Band

EUT Test Condition		Measurement Detail	
Channel	Channel 116	Frequency Range	1 GHz ~ 40 GHz
Input Power	120 Vac, 60 Hz	Detector Function	Peak (PK) Average (AV)
Environmental Conditions	25 deg. C, 65 % RH	Tested By	Gavin Wu

Antenna Polarity & Test Distance: Horizontal at 3 m										
Frequency (MHz)	Emission Level (dBuV/m)	Read Level (dBuV)	Limit (dBuV/m)	Margin (dB)	Antenna Factor (dB/m)	Cable Loss (dB)	Preamp Factor (dB)	Antenna Height (cm)	Table Angle (Degree)	Remark
5434	41.21	40.47	54	-12.79	31.55	6.32	37.13	101	100	Average
5434	60.33	59.59	74	-13.67	31.55	6.32	37.13	101	100	Peak
5470	60.36	59.53	68.2	-7.84	31.57	6.34	37.08	101	100	Peak
5580	95.34	94.3			31.71	6.49	37.16	101	100	Average
5580	105.5	104.46			31.71	6.49	37.16	101	100	Peak
5725	59.83	58.55	68.2	-8.37	31.96	6.75	37.43	101	100	Peak
Antenna Polarity & Test Distance: Vertical at 3 m										
Frequency (MHz)	Emission Level (dBuV/m)	Read Level (dBuV)	Limit (dBuV/m)	Margin (dB)	Antenna Factor (dB/m)	Cable Loss (dB)	Preamp Factor (dB)	Antenna Height (cm)	Table Angle (Degree)	Remark
5364	48.45	47.83	54	-5.55	31.49	6.31	37.18	209	284	Average
5364	63.34	62.72	74	-10.66	31.49	6.31	37.18	209	284	Peak
5470	61.91	61.08	68.2	-6.29	31.57	6.34	37.08	209	284	Peak
5580	103.34	102.3			31.71	6.49	37.16	209	284	Average
5580	113.26	112.22			31.71	6.49	37.16	209	284	Peak
5725	60.74	59.46	68.2	-7.46	31.96	6.75	37.43	209	284	Peak

Remarks:

- Emission Level = Read Level + Antenna Factor + Cable Loss - Preamp Factor
Margin value = Emission level – Limit value
- 5580 MHz: Fundamental Frequency
- 5470 MHz & 5725 MHz: Out of Restricted Band

EUT Test Condition		Measurement Detail	
Channel	Channel 140	Frequency Range	1 GHz ~ 40 GHz
Input Power	120 Vac, 60 Hz	Detector Function	Peak (PK) Average (AV)
Environmental Conditions	25 deg. C, 65 % RH	Tested By	Gavin Wu

Antenna Polarity & Test Distance: Horizontal at 3 m										
Frequency (MHz)	Emission Level (dBuV/m)	Read Level (dBuV)	Limit (dBuV/m)	Margin (dB)	Antenna Factor (dB/m)	Cable Loss (dB)	Preamp Factor (dB)	Antenna Height (cm)	Table Angle (Degree)	Remark
5436	41.69	40.95	54	-12.31	31.55	6.32	37.13	100	126	Average
5436	61.09	60.35	74	-12.91	31.55	6.32	37.13	100	126	Peak
5470	58.71	57.88	68.2	-9.49	31.57	6.34	37.08	100	126	Peak
5700	95.27	94.08			31.9	6.69	37.4	100	126	Average
5700	105.09	103.9			31.9	6.69	37.4	100	126	Peak
5725	59.66	58.38	68.2	-8.54	31.96	6.75	37.43	100	126	Peak
Antenna Polarity & Test Distance: Vertical at 3 m										
Frequency (MHz)	Emission Level (dBuV/m)	Read Level (dBuV)	Limit (dBuV/m)	Margin (dB)	Antenna Factor (dB/m)	Cable Loss (dB)	Preamp Factor (dB)	Antenna Height (cm)	Table Angle (Degree)	Remark
5354	49.46	48.87	54	-4.54	31.48	6.29	37.18	209	284	Average
5354	64.28	63.69	74	-9.72	31.48	6.29	37.18	209	284	Peak
5470	61.33	60.5	68.2	-6.87	31.57	6.34	37.08	209	284	Peak
5700	104.15	102.96			31.9	6.69	37.4	209	284	Average
5700	114.11	112.92			31.9	6.69	37.4	209	284	Peak
5725	66.24	64.96	68.2	-1.96	31.96	6.75	37.43	209	284	Peak

Remarks:

- Emission Level = Read Level + Antenna Factor + Cable Loss - Preamp Factor
Margin value = Emission level – Limit value
- 5700 MHz: Fundamental Frequency
- 5470 MHz & 5725 MHz: Out of Restricted Band

EUT Test Condition		Measurement Detail	
Channel	Channel 149	Frequency Range	1 GHz ~ 40 GHz
Input Power	120 Vac, 60 Hz	Detector Function	Peak (PK) Average (AV)
Environmental Conditions	25 deg. C, 65 % RH	Tested By	Gavin Wu

Antenna Polarity & Test Distance: Horizontal at 3 m										
Frequency (MHz)	Emission Level (dBuV/m)	Read Level (dBuV)	Limit (dBuV/m)	Margin (dB)	Antenna Factor (dB/m)	Cable Loss (dB)	Preamp Factor (dB)	Antenna Height (cm)	Table Angle (Degree)	Remark
*5714	59.31	58.12	68.2	-8.89	31.93	6.69	37.43	224	256	Peak
*5725	64.7	63.42	78.2	-13.5	31.96	6.75	37.43	224	256	Peak
5745	95.86	94.59			31.99	6.75	37.47	224	256	Average
5745	105.71	104.44			31.99	6.75	37.47	224	256	Peak
*5850	58.69	57.17	78.2	-19.51	32.15	6.88	37.51	224	256	Peak
*5861	60.87	59.24	68.2	-7.33	32.18	6.95	37.5	224	256	Peak
Antenna Polarity & Test Distance: Vertical at 3 m										
Frequency (MHz)	Emission Level (dBuV/m)	Read Level (dBuV)	Limit (dBuV/m)	Margin (dB)	Antenna Factor (dB/m)	Cable Loss (dB)	Preamp Factor (dB)	Antenna Height (cm)	Table Angle (Degree)	Remark
*5714	61.78	60.59	68.2	-6.42	31.93	6.69	37.43	201	282	Peak
*5725	76.88	75.6	78.2	-1.32	31.96	6.75	37.43	201	282	Peak
5745	106.74	105.47			31.99	6.75	37.47	201	282	Average
5745	114.95	113.68			31.99	6.75	37.47	201	282	Peak
*5850	61.31	59.79	78.2	-16.89	32.15	6.88	37.51	201	282	Peak
*5861	60.06	58.43	68.2	-8.14	32.18	6.95	37.5	201	282	Peak

Remarks:

- Emission Level = Read Level + Antenna Factor + Cable Loss - Preamp Factor
Margin value = Emission level – Limit value
- 5745 MHz: Fundamental Frequency
- *: Out of Restricted Band

EUT Test Condition		Measurement Detail	
Channel	Channel 157	Frequency Range	1 GHz ~ 40 GHz
Input Power	120 Vac, 60 Hz	Detector Function	Peak (PK) Average (AV)
Environmental Conditions	25 deg. C, 65 % RH	Tested By	Gavin Wu

Antenna Polarity & Test Distance: Horizontal at 3 m										
Frequency (MHz)	Emission Level (dBuV/m)	Read Level (dBuV)	Limit (dBuV/m)	Margin (dB)	Antenna Factor (dB/m)	Cable Loss (dB)	Preamp Factor (dB)	Antenna Height (cm)	Table Angle (Degree)	Remark
*5714	60.37	59.18	68.2	-7.83	31.93	6.69	37.43	220	255	Peak
*5725	59.34	58.06	78.2	-18.86	31.96	6.75	37.43	220	255	Peak
5785	96.36	95.04			32.04	6.82	37.54	220	255	Average
5785	105.9	104.58			32.04	6.82	37.54	220	255	Peak
*5850	60.46	58.94	78.2	-17.74	32.15	6.88	37.51	220	255	Peak
*5861	59.38	57.75	68.2	-8.82	32.18	6.95	37.5	220	255	Peak
Antenna Polarity & Test Distance: Vertical at 3 m										
Frequency (MHz)	Emission Level (dBuV/m)	Read Level (dBuV)	Limit (dBuV/m)	Margin (dB)	Antenna Factor (dB/m)	Cable Loss (dB)	Preamp Factor (dB)	Antenna Height (cm)	Table Angle (Degree)	Remark
*5714	61.68	60.49	68.2	-6.52	31.93	6.69	37.43	200	284	Peak
*5725	61.91	60.63	78.2	-16.29	31.96	6.75	37.43	200	284	Peak
5785	106.9	105.58			32.04	6.82	37.54	200	284	Average
5785	115.75	114.43			32.04	6.82	37.54	200	284	Peak
*5850	62.51	60.99	78.2	-15.69	32.15	6.88	37.51	200	284	Peak
*5861	60.51	58.88	68.2	-7.69	32.18	6.95	37.5	200	284	Peak

Remarks:

- Emission Level = Read Level + Antenna Factor + Cable Loss - Preamp Factor
Margin value = Emission level – Limit value
- 5785 MHz: Fundamental Frequency
- *: Out of Restricted Band

EUT Test Condition		Measurement Detail	
Channel	Channel 165	Frequency Range	1 GHz ~ 40 GHz
Input Power	120 Vac, 60 Hz	Detector Function	Peak (PK) Average (AV)
Environmental Conditions	25 deg. C, 65 % RH	Tested By	Gavin Wu

Antenna Polarity & Test Distance: Horizontal at 3 m										
Frequency (MHz)	Emission Level (dBuV/m)	Read Level (dBuV)	Limit (dBuV/m)	Margin (dB)	Antenna Factor (dB/m)	Cable Loss (dB)	Preamp Factor (dB)	Antenna Height (cm)	Table Angle (Degree)	Remark
*5714	59.41	58.22	68.2	-8.79	31.93	6.69	37.43	220	247	Peak
*5725	59.86	58.58	78.2	-18.34	31.96	6.75	37.43	220	247	Peak
5825	96.5	95.03			32.12	6.88	37.53	220	247	Average
5825	105.82	104.35			32.12	6.88	37.53	220	247	Peak
*5850	62.59	61.07	78.2	-15.61	32.15	6.88	37.51	220	247	Peak
*5861	59.49	57.86	68.2	-8.71	32.18	6.95	37.5	220	247	Peak
Antenna Polarity & Test Distance: Vertical at 3 m										
Frequency (MHz)	Emission Level (dBuV/m)	Read Level (dBuV)	Limit (dBuV/m)	Margin (dB)	Antenna Factor (dB/m)	Cable Loss (dB)	Preamp Factor (dB)	Antenna Height (cm)	Table Angle (Degree)	Remark
*5714	62.02	60.83	68.2	-6.18	31.93	6.69	37.43	204	279	Peak
*5725	61.45	60.17	78.2	-16.75	31.96	6.75	37.43	204	279	Peak
5825	106.94	105.47			32.12	6.88	37.53	204	279	Average
5825	115.32	113.85			32.12	6.88	37.53	204	279	Peak
*5850	65.5	63.98	78.2	-12.7	32.15	6.88	37.51	204	279	Peak
*5861	62.96	61.33	68.2	-5.24	32.18	6.95	37.5	204	279	Peak

Remarks:

- Emission Level = Read Level + Antenna Factor + Cable Loss - Preamp Factor
Margin value = Emission level – Limit value
- 5825 MHz: Fundamental Frequency
- *: Out of Restricted Band

802.11n (HT40)

EUT Test Condition		Measurement Detail	
Channel	Channel 38	Frequency Range	1 GHz ~ 40 GHz
Input Power	120 Vac, 60 Hz	Detector Function	Peak (PK) Average (AV)
Environmental Conditions	25 deg. C, 65 % RH	Tested By	Gavin Wu

Antenna Polarity & Test Distance: Horizontal at 3 m

Frequency (MHz)	Emission Level (dBuV/m)	Read Level (dBuV)	Limit (dBuV/m)	Margin (dB)	Antenna Factor (dB/m)	Cable Loss (dB)	Preamp Factor (dB)	Antenna Height (cm)	Table Angle (Degree)	Remark
5040	41.73	41.58	54	-12.27	31.24	6.15	37.24	221	248	Average
5040	60.72	60.57	74	-13.28	31.24	6.15	37.24	221	248	Peak
5190	90.61	90.38			31.35	6.22	37.34	221	248	Average
5190	100.07	99.84			31.35	6.22	37.34	221	248	Peak
5420	40.87	40.2	54	-13.13	31.53	6.32	37.18	221	248	Average
5420	61.23	60.56	74	-12.77	31.53	6.32	37.18	221	248	Peak

Antenna Polarity & Test Distance: Vertical at 3 m

Frequency (MHz)	Emission Level (dBuV/m)	Read Level (dBuV)	Limit (dBuV/m)	Margin (dB)	Antenna Factor (dB/m)	Cable Loss (dB)	Preamp Factor (dB)	Antenna Height (cm)	Table Angle (Degree)	Remark
5150	52.83	52.63	54	-1.17	31.32	6.2	37.32	210	283	Average
5150	64.8	64.6	74	-9.2	31.32	6.2	37.32	210	283	Peak
5190	101.4	101.17			31.35	6.22	37.34	210	283	Average
5190	110.29	110.06			31.35	6.22	37.34	210	283	Peak
5382	47.28	46.64	54	-6.72	31.51	6.31	37.18	210	283	Average
5382	61.65	61.01	74	-12.35	31.51	6.31	37.18	210	283	Peak

Remarks:

- Emission Level = Read Level + Antenna Factor + Cable Loss - Preamp Factor
Margin value = Emission level – Limit value
- 5190 MHz: Fundamental Frequency

EUT Test Condition		Measurement Detail	
Channel	Channel 46	Frequency Range	1 GHz ~ 40 GHz
Input Power	120 Vac, 60 Hz	Detector Function	Peak (PK) Average (AV)
Environmental Conditions	25 deg. C, 65 % RH	Tested By	Gavin Wu

Antenna Polarity & Test Distance: Horizontal at 3 m										
Frequency (MHz)	Emission Level (dBuV/m)	Read Level (dBuV)	Limit (dBuV/m)	Margin (dB)	Antenna Factor (dB/m)	Cable Loss (dB)	Preamp Factor (dB)	Antenna Height (cm)	Table Angle (Degree)	Remark
5128	40.88	40.67	54	-13.12	31.31	6.2	37.3	218	257	Average
5128	60.56	60.35	74	-13.44	31.31	6.2	37.3	218	257	Peak
5230	96.44	96.13			31.39	6.24	37.32	218	257	Average
5230	105.6	105.29			31.39	6.24	37.32	218	257	Peak
5426	41.95	41.23	54	-12.05	31.53	6.32	37.13	218	257	Average
5426	60.67	59.95	74	-13.33	31.53	6.32	37.13	218	257	Peak

Antenna Polarity & Test Distance: Vertical at 3 m										
Frequency (MHz)	Emission Level (dBuV/m)	Read Level (dBuV)	Limit (dBuV/m)	Margin (dB)	Antenna Factor (dB/m)	Cable Loss (dB)	Preamp Factor (dB)	Antenna Height (cm)	Table Angle (Degree)	Remark
5140	49.58	49.36	54	-4.42	31.32	6.2	37.3	210	280	Average
5140	64.02	63.8	74	-9.98	31.32	6.2	37.3	210	280	Peak
5230	107.44	107.13			31.39	6.24	37.32	210	280	Average
5230	114.92	114.61			31.39	6.24	37.32	210	280	Peak
5354	50.41	49.82	54	-3.59	31.48	6.29	37.18	210	280	Average
5354	63.69	63.1	74	-10.31	31.48	6.29	37.18	210	280	Peak

Remarks:

- Emission Level = Read Level + Antenna Factor + Cable Loss - Preamp Factor
Margin value = Emission level – Limit value
- 5230 MHz: Fundamental Frequency

EUT Test Condition		Measurement Detail	
Channel	Channel 54	Frequency Range	1 GHz ~ 40 GHz
Input Power	120 Vac, 60 Hz	Detector Function	Peak (PK) Average (AV)
Environmental Conditions	25 deg. C, 65 % RH	Tested By	Gavin Wu

Antenna Polarity & Test Distance: Horizontal at 3 m										
Frequency (MHz)	Emission Level (dBuV/m)	Read Level (dBuV)	Limit (dBuV/m)	Margin (dB)	Antenna Factor (dB/m)	Cable Loss (dB)	Preamp Factor (dB)	Antenna Height (cm)	Table Angle (Degree)	Remark
5066	43.27	43.1	54	-10.73	31.25	6.17	37.25	185	30	Average
5066	60.91	60.74	74	-13.09	31.25	6.17	37.25	185	30	Peak
5270	99.87	99.48			31.41	6.25	37.27	185	30	Average
5270	109.33	108.94			31.41	6.25	37.27	185	30	Peak
5364	43.53	42.91	54	-10.47	31.49	6.31	37.18	185	30	Average
5364	61.05	60.43	74	-12.95	31.49	6.31	37.18	185	30	Peak
Antenna Polarity & Test Distance: Vertical at 3 m										
Frequency (MHz)	Emission Level (dBuV/m)	Read Level (dBuV)	Limit (dBuV/m)	Margin (dB)	Antenna Factor (dB/m)	Cable Loss (dB)	Preamp Factor (dB)	Antenna Height (cm)	Table Angle (Degree)	Remark
5148	44.92	44.72	54	-9.08	31.32	6.2	37.32	212	287	Average
5148	61.2	61	74	-12.8	31.32	6.2	37.32	212	287	Peak
5270	101.7	101.31			31.41	6.25	37.27	212	287	Average
5270	110.52	110.13			31.41	6.25	37.27	212	287	Peak
5446	44.11	43.34	54	-9.89	31.56	6.34	37.13	212	287	Average
5446	61.13	60.36	74	-12.87	31.56	6.34	37.13	212	287	Peak

Remarks:

- Emission Level = Read Level + Antenna Factor + Cable Loss - Preamp Factor
Margin value = Emission level – Limit value
- 5270 MHz: Fundamental Frequency

EUT Test Condition		Measurement Detail	
Channel	Channel 62	Frequency Range	1 GHz ~ 40 GHz
Input Power	120 Vac, 60 Hz	Detector Function	Peak (PK) Average (AV)
Environmental Conditions	25 deg. C, 65 % RH	Tested By	Gavin Wu

Antenna Polarity & Test Distance: Horizontal at 3 m

Frequency (MHz)	Emission Level (dBuV/m)	Read Level (dBuV)	Limit (dBuV/m)	Margin (dB)	Antenna Factor (dB/m)	Cable Loss (dB)	Preamp Factor (dB)	Antenna Height (cm)	Table Angle (Degree)	Remark
5028	41.27	41.13	54	-12.73	31.23	6.15	37.24	146	30	Average
5028	61.19	61.05	74	-12.81	31.23	6.15	37.24	146	30	Peak
5310	94.67	94.14			31.45	6.27	37.19	146	30	Average
5310	104.52	103.99			31.45	6.27	37.19	146	30	Peak
5350	52.97	52.38	54	-1.03	31.48	6.29	37.18	146	30	Average
5350	69.16	68.57	74	-4.84	31.48	6.29	37.18	146	30	Peak

Antenna Polarity & Test Distance: Vertical at 3 m

Frequency (MHz)	Emission Level (dBuV/m)	Read Level (dBuV)	Limit (dBuV/m)	Margin (dB)	Antenna Factor (dB/m)	Cable Loss (dB)	Preamp Factor (dB)	Antenna Height (cm)	Table Angle (Degree)	Remark
5124	44.63	44.43	54	-9.37	31.31	6.19	37.3	213	286	Average
5124	61.96	61.76	74	-12.04	31.31	6.19	37.3	213	286	Peak
5310	99.16	98.63			31.45	6.27	37.19	213	286	Average
5310	108.49	107.96			31.45	6.27	37.19	213	286	Peak
5350	50.72	50.13	54	-3.28	31.48	6.29	37.18	213	286	Average
5350	65.63	65.04	74	-8.37	31.48	6.29	37.18	213	286	Peak

Remarks:

- Emission Level = Read Level + Antenna Factor + Cable Loss - Preamp Factor
Margin value = Emission level – Limit value
- 5310 MHz: Fundamental Frequency

EUT Test Condition		Measurement Detail	
Channel	Channel 102	Frequency Range	1 GHz ~ 40 GHz
Input Power	120 Vac, 60 Hz	Detector Function	Peak (PK) Average (AV)
Environmental Conditions	25 deg. C, 65 % RH	Tested By	Gavin Wu

Antenna Polarity & Test Distance: Horizontal at 3 m										
Frequency (MHz)	Emission Level (dBuV/m)	Read Level (dBuV)	Limit (dBuV/m)	Margin (dB)	Antenna Factor (dB/m)	Cable Loss (dB)	Preamp Factor (dB)	Antenna Height (cm)	Table Angle (Degree)	Remark
5460	44.45	43.63	54	-9.55	31.56	6.34	37.08	100	64	Average
5460	62.28	61.46	74	-11.72	31.56	6.34	37.08	100	64	Peak
5470	62.29	61.46	68.2	-5.91	31.57	6.34	37.08	100	64	Peak
5510	93.26	92.36			31.6	6.36	37.06	100	64	Average
5510	103.38	102.48			31.6	6.36	37.06	100	64	Peak
5725	60.93	59.65	68.2	-7.27	31.96	6.75	37.43	100	64	Peak
Antenna Polarity & Test Distance: Vertical at 3 m										
Frequency (MHz)	Emission Level (dBuV/m)	Read Level (dBuV)	Limit (dBuV/m)	Margin (dB)	Antenna Factor (dB/m)	Cable Loss (dB)	Preamp Factor (dB)	Antenna Height (cm)	Table Angle (Degree)	Remark
5460	50	49.18	54	-4	31.56	6.34	37.08	201	285	Average
5460	67.02	66.2	74	-6.98	31.56	6.34	37.08	201	285	Peak
5470	67.19	66.36	68.2	-1.01	31.57	6.34	37.08	201	285	Peak
5510	100.03	99.13			31.6	6.36	37.06	201	285	Average
5510	109.86	108.96			31.6	6.36	37.06	201	285	Peak
5725	60.89	59.61	68.2	-7.31	31.96	6.75	37.43	201	285	Peak

Remarks:

- Emission Level = Read Level + Antenna Factor + Cable Loss - Preamp Factor
Margin value = Emission level – Limit value
- 5510 MHz: Fundamental Frequency
- 5470 MHz & 5725 MHz: Out of Restricted Band

EUT Test Condition		Measurement Detail	
Channel	Channel 110	Frequency Range	1 GHz ~ 40 GHz
Input Power	120 Vac, 60 Hz	Detector Function	Peak (PK) Average (AV)
Environmental Conditions	25 deg. C, 65 % RH	Tested By	Gavin Wu

Antenna Polarity & Test Distance: Horizontal at 3 m										
Frequency (MHz)	Emission Level (dBuV/m)	Read Level (dBuV)	Limit (dBuV/m)	Margin (dB)	Antenna Factor (dB/m)	Cable Loss (dB)	Preamp Factor (dB)	Antenna Height (cm)	Table Angle (Degree)	Remark
5444	40.2	39.44	54	-13.8	31.55	6.34	37.13	100	163	Average
5444	61.43	60.67	74	-12.57	31.55	6.34	37.13	100	163	Peak
5470	59.59	58.76	68.2	-8.61	31.57	6.34	37.08	100	163	Peak
5550	93.83	92.82			31.68	6.42	37.09	100	163	Average
5550	104.51	103.5			31.68	6.42	37.09	100	163	Peak
5725	60.42	59.14	68.2	-7.78	31.96	6.75	37.43	100	163	Peak
Antenna Polarity & Test Distance: Vertical at 3 m										
Frequency (MHz)	Emission Level (dBuV/m)	Read Level (dBuV)	Limit (dBuV/m)	Margin (dB)	Antenna Factor (dB/m)	Cable Loss (dB)	Preamp Factor (dB)	Antenna Height (cm)	Table Angle (Degree)	Remark
5376	45.68	45.06	54	-8.32	31.49	6.31	37.18	208	288	Average
5376	61.81	61.19	74	-12.19	31.49	6.31	37.18	208	288	Peak
5470	61.09	60.26	68.2	-7.11	31.57	6.34	37.08	208	288	Peak
5550	101.63	100.62			31.68	6.42	37.09	208	288	Average
5550	111.83	110.82			31.68	6.42	37.09	208	288	Peak
5725	60.75	59.47	68.2	-7.45	31.96	6.75	37.43	208	288	Peak

Remarks:

- Emission Level = Read Level + Antenna Factor + Cable Loss - Preamp Factor
Margin value = Emission level – Limit value
- 5550 MHz: Fundamental Frequency
- 5470 MHz & 5725 MHz: Out of Restricted Band

EUT Test Condition		Measurement Detail	
Channel	Channel 134	Frequency Range	1 GHz ~ 40 GHz
Input Power	120 Vac, 60 Hz	Detector Function	Peak (PK) Average (AV)
Environmental Conditions	25 deg. C, 65 % RH	Tested By	Gavin Wu

Antenna Polarity & Test Distance: Horizontal at 3 m										
Frequency (MHz)	Emission Level (dBuV/m)	Read Level (dBuV)	Limit (dBuV/m)	Margin (dB)	Antenna Factor (dB/m)	Cable Loss (dB)	Preamp Factor (dB)	Antenna Height (cm)	Table Angle (Degree)	Remark
5412	42.13	41.46	54	-11.87	31.53	6.32	37.18	100	213	Average
5412	61.2	60.53	74	-12.8	31.53	6.32	37.18	100	213	Peak
5470	60.84	60.01	68.2	-7.36	31.57	6.34	37.08	100	213	Peak
5670	94.3	93.14			31.88	6.62	37.34	100	213	Average
5670	103.57	102.41			31.88	6.62	37.34	100	213	Peak
5725	59.27	57.99	68.2	-8.93	31.96	6.75	37.43	100	213	Peak
Antenna Polarity & Test Distance: Vertical at 3 m										
Frequency (MHz)	Emission Level (dBuV/m)	Read Level (dBuV)	Limit (dBuV/m)	Margin (dB)	Antenna Factor (dB/m)	Cable Loss (dB)	Preamp Factor (dB)	Antenna Height (cm)	Table Angle (Degree)	Remark
5430	46.39	45.65	54	-7.61	31.55	6.32	37.13	214	285	Average
5430	63.08	62.34	74	-10.92	31.55	6.32	37.13	214	285	Peak
5470	61.53	60.7	68.2	-6.67	31.57	6.34	37.08	214	285	Peak
5670	101	99.84			31.88	6.62	37.34	214	285	Average
5670	110.56	109.4			31.88	6.62	37.34	214	285	Peak
5725	62.21	60.93	68.2	-5.99	31.96	6.75	37.43	214	285	Peak

Remarks:

- Emission Level = Read Level + Antenna Factor + Cable Loss - Preamp Factor
Margin value = Emission level – Limit value
- 5670 MHz: Fundamental Frequency
- 5470 MHz & 5725 MHz: Out of Restricted Band

EUT Test Condition		Measurement Detail	
Channel	Channel 151	Frequency Range	1 GHz ~ 40 GHz
Input Power	120 Vac, 60 Hz	Detector Function	Peak (PK) Average (AV)
Environmental Conditions	25 deg. C, 65 % RH	Tested By	Gavin Wu

Antenna Polarity & Test Distance: Horizontal at 3 m										
Frequency (MHz)	Emission Level (dBuV/m)	Read Level (dBuV)	Limit (dBuV/m)	Margin (dB)	Antenna Factor (dB/m)	Cable Loss (dB)	Preamp Factor (dB)	Antenna Height (cm)	Table Angle (Degree)	Remark
*5714	61.07	59.88	68.2	-7.13	31.93	6.69	37.43	222	259	Peak
*5725	70.31	69.03	78.2	-7.89	31.96	6.75	37.43	222	259	Peak
5755	93.24	91.95			32.01	6.75	37.47	222	259	Average
5755	102.65	101.36			32.01	6.75	37.47	222	259	Peak
*5850	58.75	57.23	78.2	-19.45	32.15	6.88	37.51	222	259	Peak
*5861	60.7	59.07	68.2	-7.5	32.18	6.95	37.5	222	259	Peak
Antenna Polarity & Test Distance: Vertical at 3 m										
Frequency (MHz)	Emission Level (dBuV/m)	Read Level (dBuV)	Limit (dBuV/m)	Margin (dB)	Antenna Factor (dB/m)	Cable Loss (dB)	Preamp Factor (dB)	Antenna Height (cm)	Table Angle (Degree)	Remark
*5714	67.07	65.88	68.2	-1.13	31.93	6.69	37.43	206	280	Peak
*5725	76.92	75.64	78.2	-1.28	31.96	6.75	37.43	206	280	Peak
5755	103.33	102.04			32.01	6.75	37.47	206	280	Average
5755	111.57	110.28			32.01	6.75	37.47	206	280	Peak
*5850	59.35	57.83	78.2	-18.85	32.15	6.88	37.51	206	280	Peak
*5861	59.82	58.19	68.2	-8.38	32.18	6.95	37.5	206	280	Peak

Remarks:

- Emission Level = Read Level + Antenna Factor + Cable Loss - Preamp Factor
Margin value = Emission level – Limit value
- 5755 MHz: Fundamental Frequency
- *: Out of Restricted Band

EUT Test Condition		Measurement Detail	
Channel	Channel 159	Frequency Range	1 GHz ~ 40 GHz
Input Power	120 Vac, 60 Hz	Detector Function	Peak (PK) Average (AV)
Environmental Conditions	25 deg. C, 65 % RH	Tested By	Gavin Wu

Antenna Polarity & Test Distance: Horizontal at 3 m										
Frequency (MHz)	Emission Level (dBuV/m)	Read Level (dBuV)	Limit (dBuV/m)	Margin (dB)	Antenna Factor (dB/m)	Cable Loss (dB)	Preamp Factor (dB)	Antenna Height (cm)	Table Angle (Degree)	Remark
*5714	58.69	57.5	68.2	-9.51	31.93	6.69	37.43	224	268	Peak
*5725	59.29	58.01	78.2	-18.91	31.96	6.75	37.43	224	268	Peak
5795	94.86	93.51			32.07	6.82	37.54	224	268	Average
5795	104.11	102.76			32.07	6.82	37.54	224	268	Peak
*5850	61.2	59.68	78.2	-17	32.15	6.88	37.51	224	268	Peak
*5861	60.35	58.72	68.2	-7.85	32.18	6.95	37.5	224	268	Peak
Antenna Polarity & Test Distance: Vertical at 3 m										
Frequency (MHz)	Emission Level (dBuV/m)	Read Level (dBuV)	Limit (dBuV/m)	Margin (dB)	Antenna Factor (dB/m)	Cable Loss (dB)	Preamp Factor (dB)	Antenna Height (cm)	Table Angle (Degree)	Remark
*5714	60.31	59.12	68.2	-7.89	31.93	6.69	37.43	208	278	Peak
*5725	59.92	58.64	78.2	-18.28	31.96	6.75	37.43	208	278	Peak
5795	105.11	103.76			32.07	6.82	37.54	208	278	Average
5795	113.5	112.15			32.07	6.82	37.54	208	278	Peak
*5850	59.27	57.75	78.2	-18.93	32.15	6.88	37.51	208	278	Peak
*5861	61.69	60.06	68.2	-6.51	32.18	6.95	37.5	208	278	Peak

Remarks:

- Emission Level = Read Level + Antenna Factor + Cable Loss - Preamp Factor
Margin value = Emission level – Limit value
- 5795 MHz: Fundamental Frequency
- *: Out of Restricted Band

802.11ac (VHT80)

EUT Test Condition		Measurement Detail	
Channel	Channel 42	Frequency Range	1 GHz ~ 40 GHz
Input Power	120 Vac, 60 Hz	Detector Function	Peak (PK) Average (AV)
Environmental Conditions	25 deg. C, 65 % RH	Tested By	Gavin Wu

Antenna Polarity & Test Distance: Horizontal at 3 m

Frequency (MHz)	Emission Level (dBuV/m)	Read Level (dBuV)	Limit (dBuV/m)	Margin (dB)	Antenna Factor (dB/m)	Cable Loss (dB)	Preamp Factor (dB)	Antenna Height (cm)	Table Angle (Degree)	Remark
5024	40.48	40.34	54	-13.52	31.23	6.15	37.24	127	255	Average
5024	60.38	60.24	74	-13.62	31.23	6.15	37.24	127	255	Peak
5210	82.36	82.11			31.37	6.24	37.36	127	255	Average
5210	91.93	91.68			31.37	6.24	37.36	127	255	Peak
5420	38.28	37.61	54	-15.72	31.53	6.32	37.18	127	255	Average
5420	60.17	59.5	74	-13.83	31.53	6.32	37.18	127	255	Peak

Antenna Polarity & Test Distance: Vertical at 3 m

Frequency (MHz)	Emission Level (dBuV/m)	Read Level (dBuV)	Limit (dBuV/m)	Margin (dB)	Antenna Factor (dB/m)	Cable Loss (dB)	Preamp Factor (dB)	Antenna Height (cm)	Table Angle (Degree)	Remark
5136	50.04	49.83	54	-3.96	31.31	6.2	37.3	206	72	Average
5136	64.19	63.98	74	-9.81	31.31	6.2	37.3	206	72	Peak
5210	95.24	94.99			31.37	6.24	37.36	206	72	Average
5210	104.59	104.34			31.37	6.24	37.36	206	72	Peak
5378	41.4	40.76	54	-12.6	31.51	6.31	37.18	206	72	Average
5378	61.04	60.4	74	-12.96	31.51	6.31	37.18	206	72	Peak

Remarks:

- Emission Level = Read Level + Antenna Factor + Cable Loss - Preamp Factor
Margin value = Emission level – Limit value
- 5210 MHz: Fundamental Frequency

EUT Test Condition		Measurement Detail	
Channel	Channel 58	Frequency Range	1 GHz ~ 40 GHz
Input Power	120 Vac, 60 Hz	Detector Function	Peak (PK) Average (AV)
Environmental Conditions	25 deg. C, 65 % RH	Tested By	Gavin Wu

Antenna Polarity & Test Distance: Horizontal at 3 m										
Frequency (MHz)	Emission Level (dBuV/m)	Read Level (dBuV)	Limit (dBuV/m)	Margin (dB)	Antenna Factor (dB/m)	Cable Loss (dB)	Preamp Factor (dB)	Antenna Height (cm)	Table Angle (Degree)	Remark
5068	38.67	38.52	54	-15.33	31.25	6.17	37.27	254	250	Average
5068	60.83	60.68	74	-13.17	31.25	6.17	37.27	254	250	Peak
5290	84.41	83.94			31.43	6.27	37.23	254	250	Average
5290	93.64	93.17			31.43	6.27	37.23	254	250	Peak
5456	45.48	44.66	54	-8.52	31.56	6.34	37.08	254	250	Average
5456	60.33	59.51	74	-13.67	31.56	6.34	37.08	254	250	Peak

Antenna Polarity & Test Distance: Vertical at 3 m										
Frequency (MHz)	Emission Level (dBuV/m)	Read Level (dBuV)	Limit (dBuV/m)	Margin (dB)	Antenna Factor (dB/m)	Cable Loss (dB)	Preamp Factor (dB)	Antenna Height (cm)	Table Angle (Degree)	Remark
5022	41.98	41.84	54	-12.02	31.23	6.15	37.24	203	71	Average
5022	60.8	60.66	74	-13.2	31.23	6.15	37.24	203	71	Peak
5290	95.44	94.97			31.43	6.27	37.23	203	71	Average
5290	104.33	103.86			31.43	6.27	37.23	203	71	Peak
5350	52.49	51.9	54	-1.51	31.48	6.29	37.18	203	71	Average
5350	64.54	63.95	74	-9.46	31.48	6.29	37.18	203	71	Peak

Remarks:

- Emission Level = Read Level + Antenna Factor + Cable Loss - Preamp Factor
Margin value = Emission level – Limit value
- 5290 MHz: Fundamental Frequency

EUT Test Condition		Measurement Detail	
Channel	Channel 106	Frequency Range	1 GHz ~ 40 GHz
Input Power	120 Vac, 60 Hz	Detector Function	Peak (PK) Average (AV)
Environmental Conditions	25 deg. C, 65 % RH	Tested By	Gavin Wu

Antenna Polarity & Test Distance: Horizontal at 3 m										
Frequency (MHz)	Emission Level (dBuV/m)	Read Level (dBuV)	Limit (dBuV/m)	Margin (dB)	Antenna Factor (dB/m)	Cable Loss (dB)	Preamp Factor (dB)	Antenna Height (cm)	Table Angle (Degree)	Remark
5460	51.06	50.24	54	-2.94	31.56	6.34	37.08	254	252	Average
5460	64.91	64.09	74	-9.09	31.56	6.34	37.08	254	252	Peak
5470	58.93	58.1	68.2	-9.27	31.57	6.34	37.08	254	252	Peak
5530	83.23	82.27			31.63	6.42	37.09	254	252	Average
5530	96.48	95.52			31.63	6.42	37.09	254	252	Peak
5725	59.51	58.23	68.2	-8.69	31.96	6.75	37.43	254	252	Peak
Antenna Polarity & Test Distance: Vertical at 3 m										
Frequency (MHz)	Emission Level (dBuV/m)	Read Level (dBuV)	Limit (dBuV/m)	Margin (dB)	Antenna Factor (dB/m)	Cable Loss (dB)	Preamp Factor (dB)	Antenna Height (cm)	Table Angle (Degree)	Remark
5460	52.16	51.34	54	-1.84	31.56	6.34	37.08	200	71	Average
5460	63.23	62.41	74	-10.77	31.56	6.34	37.08	200	71	Peak
5470	60.88	60.05	68.2	-7.32	31.57	6.34	37.08	200	71	Peak
5530	92.28	91.32			31.63	6.42	37.09	200	71	Average
5530	102.54	101.58			31.63	6.42	37.09	200	71	Peak
5725	59.05	57.77	68.2	-9.15	31.96	6.75	37.43	200	71	Peak

Remarks:

- Emission Level = Read Level + Antenna Factor + Cable Loss - Preamp Factor
Margin value = Emission level – Limit value
- 5530 MHz: Fundamental Frequency
- 5470 MHz & 5725 MHz: Out of Restricted Band

EUT Test Condition		Measurement Detail	
Channel	Channel 122	Frequency Range	1 GHz ~ 40 GHz
Input Power	120 Vac, 60 Hz	Detector Function	Peak (PK) Average (AV)
Environmental Conditions	25 deg. C, 65 % RH	Tested By	Gavin Wu

Antenna Polarity & Test Distance: Horizontal at 3 m										
Frequency (MHz)	Emission Level (dBuV/m)	Read Level (dBuV)	Limit (dBuV/m)	Margin (dB)	Antenna Factor (dB/m)	Cable Loss (dB)	Preamp Factor (dB)	Antenna Height (cm)	Table Angle (Degree)	Remark
5458	40.66	39.84	54	-13.34	31.56	6.34	37.08	259	251	Average
5458	60.41	59.59	74	-13.59	31.56	6.34	37.08	259	251	Peak
5470	59.95	59.12	68.2	-8.25	31.57	6.34	37.08	259	251	Peak
5610	91.65	90.54			31.77	6.56	37.22	259	251	Average
5610	101.12	100.01			31.77	6.56	37.22	259	251	Peak
5725	59.43	58.15	68.2	-8.77	31.96	6.75	37.43	259	251	Peak
Antenna Polarity & Test Distance: Vertical at 3 m										
Frequency (MHz)	Emission Level (dBuV/m)	Read Level (dBuV)	Limit (dBuV/m)	Margin (dB)	Antenna Factor (dB/m)	Cable Loss (dB)	Preamp Factor (dB)	Antenna Height (cm)	Table Angle (Degree)	Remark
5448	48.08	47.31	54	-5.92	31.56	6.34	37.13	207	62	Average
5448	62.08	61.31	74	-11.92	31.56	6.34	37.13	207	62	Peak
5470	60.25	59.42	68.2	-7.95	31.57	6.34	37.08	207	62	Peak
5610	98.08	96.97			31.77	6.56	37.22	207	62	Average
5610	107.49	106.38			31.77	6.56	37.22	207	62	Peak
5725	61.97	60.69	68.2	-6.23	31.96	6.75	37.43	207	62	Peak

Remarks:

- Emission Level = Read Level + Antenna Factor + Cable Loss - Preamp Factor
Margin value = Emission level – Limit value
- 5610 MHz: Fundamental Frequency
- 5470 MHz & 5725 MHz: Out of Restricted Band

EUT Test Condition		Measurement Detail	
Channel	Channel 155	Frequency Range	1 GHz ~ 40 GHz
Input Power	120 Vac, 60 Hz	Detector Function	Peak (PK) Average (AV)
Environmental Conditions	25 deg. C, 65 % RH	Tested By	Gavin Wu

Antenna Polarity & Test Distance: Horizontal at 3 m										
Frequency (MHz)	Emission Level (dBuV/m)	Read Level (dBuV)	Limit (dBuV/m)	Margin (dB)	Antenna Factor (dB/m)	Cable Loss (dB)	Preamp Factor (dB)	Antenna Height (cm)	Table Angle (Degree)	Remark
*5714	64.02	62.83	68.2	-4.18	31.93	6.69	37.43	265	256	Peak
*5725	70.39	69.11	78.2	-7.81	31.96	6.75	37.43	265	256	Peak
5775	89.04	87.68			32.04	6.82	37.5	265	256	Average
5775	98.03	96.67			32.04	6.82	37.5	265	256	Peak
*5850	61.49	59.97	78.2	-16.71	32.15	6.88	37.51	265	256	Peak
*5861	61.38	59.75	68.2	-6.82	32.18	6.95	37.5	265	256	Peak
Antenna Polarity & Test Distance: Vertical at 3 m										
Frequency (MHz)	Emission Level (dBuV/m)	Read Level (dBuV)	Limit (dBuV/m)	Margin (dB)	Antenna Factor (dB/m)	Cable Loss (dB)	Preamp Factor (dB)	Antenna Height (cm)	Table Angle (Degree)	Remark
*5714	63.38	62.19	68.2	-4.82	31.93	6.69	37.43	217	71	Peak
*5725	76.74	75.46	78.2	-1.46	31.96	6.75	37.43	217	71	Peak
5775	97.52	96.16			32.04	6.82	37.5	217	71	Average
5775	106.08	104.72			32.04	6.82	37.5	217	71	Peak
*5850	65.54	64.02	78.2	-12.66	32.15	6.88	37.51	217	71	Peak
*5861	64.23	62.6	68.2	-3.97	32.18	6.95	37.5	217	71	Peak

Remarks:

- Emission Level = Read Level + Antenna Factor + Cable Loss - Preamp Factor
Margin value = Emission level – Limit value
- 5775 MHz: Fundamental Frequency
- *: Out of Restricted Band

9 kHz ~ 30 MHz DATA:

The amplitude of spurious emissions attenuated more than 20 dB below the permissible value is not required to be report.

30 MHz ~ 1 GHz WORST-CASE DATA:

802.11n (HT40)

EUT Test Condition		Measurement Detail	
Channel	Channel 38	Frequency Range	30 MHz ~ 1 GHz
Input Power	120 Vac, 60 Hz	Detector Function	Peak (PK) Quasi-peak (QP)
Environmental Conditions	25 deg. C, 65 % RH	Tested By	Gavin Wu

Antenna Polarity & Test Distance: Horizontal at 3 m										
Frequency (MHz)	Emission Level (dBuV/m)	Read Level (dBuV)	Limit (dBuV/m)	Margin (dB)	Antenna Factor (dB/m)	Cable Loss (dB)	Preamp Factor (dB)	Antenna Height (cm)	Table Angle (Degree)	Remark
144.46	33.31	51.27	43.5	-10.19	12.51	1.16	31.63	110	173	Peak
213.33	39.82	60.17	43.5	-3.68	9.93	1.35	31.63	139	203	Peak
298.69	44.09	61.37	46	-1.91	12.91	1.63	31.82	128	174	QP
666.32	35.88	44.94	46	-10.12	20.41	2.39	31.86	127	49	Peak
697.36	44.45	53.02	46	-1.55	20.78	2.45	31.8	120	339	QP
896.21	34.18	39.98	46	-11.82	23.46	2.74	32	131	148	Peak

Antenna Polarity & Test Distance: Vertical at 3 m										
Frequency (MHz)	Emission Level (dBuV/m)	Read Level (dBuV)	Limit (dBuV/m)	Margin (dB)	Antenna Factor (dB/m)	Cable Loss (dB)	Preamp Factor (dB)	Antenna Height (cm)	Table Angle (Degree)	Remark
99.84	35.21	57.07	43.5	-8.29	9.06	1.04	31.96	139	164	Peak
221.09	31.46	51.54	46	-14.54	10.26	1.38	31.72	111	286	Peak
298.69	40.93	58.21	46	-5.07	12.91	1.63	31.82	102	28	Peak
666.32	34.96	44.02	46	-11.04	20.41	2.39	31.86	138	228	Peak
700.27	44.21	52.73	46	-1.79	20.82	2.45	31.79	137	117	QP
896.21	36.53	42.33	46	-9.47	23.46	2.74	32	113	236	Peak

Remarks:

- Emission Level = Read Level + Antenna Factor + Cable Loss - Preamp Factor
Margin value = Emission level – Limit value

802.11n (HT40)

EUT Test Condition		Measurement Detail	
Channel	Channel 62	Frequency Range	30 MHz ~ 1 GHz
Input Power	120 Vac, 60 Hz	Detector Function	Peak (PK) Quasi-peak (QP)
Environmental Conditions	25 deg. C, 65 % RH	Tested By	Gavin Wu

Antenna Polarity & Test Distance: Horizontal at 3 m										
Frequency (MHz)	Emission Level (dBuV/m)	Read Level (dBuV)	Limit (dBuV/m)	Margin (dB)	Antenna Factor (dB/m)	Cable Loss (dB)	Preamp Factor (dB)	Antenna Height (cm)	Table Angle (Degree)	Remark
144.46	32.15	50.11	43.5	-11.35	12.51	1.16	31.63	103	351	Peak
215.27	40.31	60.59	43.5	-3.19	10.01	1.36	31.65	104	172	Peak
298.69	42.53	59.81	46	-3.47	12.91	1.63	31.82	137	129	Peak
666.32	36.01	45.07	46	-9.99	20.41	2.39	31.86	125	198	Peak
697.36	43.6	52.17	46	-2.4	20.78	2.45	31.8	106	201	QP
896.21	34.67	40.47	46	-11.33	23.46	2.74	32	131	221	Peak

Antenna Polarity & Test Distance: Vertical at 3 m										
Frequency (MHz)	Emission Level (dBuV/m)	Read Level (dBuV)	Limit (dBuV/m)	Margin (dB)	Antenna Factor (dB/m)	Cable Loss (dB)	Preamp Factor (dB)	Antenna Height (cm)	Table Angle (Degree)	Remark
107.6	35	55.96	43.5	-8.5	9.81	1.09	31.86	107	316	Peak
218.18	31.59	51.78	46	-14.41	10.13	1.37	31.69	112	186	Peak
299.66	40.76	58.03	46	-5.24	12.94	1.63	31.84	117	168	Peak
663.41	34.51	43.66	46	-11.49	20.37	2.38	31.9	128	54	Peak
697.36	43.89	52.46	46	-2.11	20.78	2.45	31.8	127	252	QP
896.21	37	42.8	46	-9	23.46	2.74	32	136	130	Peak

Remarks:

- Emission Level = Read Level + Antenna Factor + Cable Loss - Preamp Factor
Margin value = Emission level – Limit value

802.11n (HT40)

EUT Test Condition		Measurement Detail	
Channel	Channel 102	Frequency Range	30 MHz ~ 1 GHz
Input Power	120 Vac, 60 Hz	Detector Function	Peak (PK) Quasi-peak (QP)
Environmental Conditions	25 deg. C, 65 % RH	Tested By	Gavin Wu

Antenna Polarity & Test Distance: Horizontal at 3 m

Frequency (MHz)	Emission Level (dBuV/m)	Read Level (dBuV)	Limit (dBuV/m)	Margin (dB)	Antenna Factor (dB/m)	Cable Loss (dB)	Preamp Factor (dB)	Antenna Height (cm)	Table Angle (Degree)	Remark
144.46	33.1	51.06	43.5	-10.4	12.51	1.16	31.63	132	145	Peak
214.3	40.29	60.61	43.5	-3.21	9.97	1.35	31.64	128	273	Peak
299.66	43.27	60.54	46	-2.73	12.94	1.63	31.84	110	89	QP
663.41	36.53	45.68	46	-9.47	20.37	2.38	31.9	122	314	Peak
697.36	43.3	51.87	46	-2.7	20.78	2.45	31.8	124	328	QP
896.21	34.11	39.91	46	-11.89	23.46	2.74	32	125	129	Peak

Antenna Polarity & Test Distance: Vertical at 3 m

Frequency (MHz)	Emission Level (dBuV/m)	Read Level (dBuV)	Limit (dBuV/m)	Margin (dB)	Antenna Factor (dB/m)	Cable Loss (dB)	Preamp Factor (dB)	Antenna Height (cm)	Table Angle (Degree)	Remark
99.84	35.26	57.12	43.5	-8.24	9.06	1.04	31.96	132	90	Peak
298.69	40.39	57.67	46	-5.61	12.91	1.63	31.82	113	188	Peak
431.58	27.02	41.11	46	-18.98	15.96	1.96	32.01	126	333	Peak
664.38	35.79	44.9	46	-10.21	20.39	2.39	31.89	106	212	Peak
697.36	43.18	51.75	46	-2.82	20.78	2.45	31.8	100	73	QP
900.09	36.59	42.34	46	-9.41	23.51	2.75	32.01	116	134	Peak

Remarks:

- Emission Level = Read Level + Antenna Factor + Cable Loss - Preamp Factor
Margin value = Emission level – Limit value

802.11n (HT40)

EUT Test Condition		Measurement Detail	
Channel	Channel 151	Frequency Range	30 MHz ~ 1 GHz
Input Power	120 Vac, 60 Hz	Detector Function	Peak (PK) Quasi-peak (QP)
Environmental Conditions	25 deg. C, 65 % RH	Tested By	Gavin Wu

Antenna Polarity & Test Distance: Horizontal at 3 m

Frequency (MHz)	Emission Level (dBuV/m)	Read Level (dBuV)	Limit (dBuV/m)	Margin (dB)	Antenna Factor (dB/m)	Cable Loss (dB)	Preamp Factor (dB)	Antenna Height (cm)	Table Angle (Degree)	Remark
99.84	32.87	54.73	43.5	-10.63	9.06	1.04	31.96	120	12	Peak
209.45	39.12	59.63	43.5	-4.38	9.77	1.33	31.61	110	67	Peak
299.66	43.88	61.15	46	-2.12	12.94	1.63	31.84	132	75	QP
666.32	36.55	45.61	46	-9.45	20.41	2.39	31.86	119	191	Peak
697.36	43.56	52.13	46	-2.44	20.78	2.45	31.8	109	196	QP
900.09	33.99	39.74	46	-12.01	23.51	2.75	32.01	122	310	Peak

Antenna Polarity & Test Distance: Vertical at 3 m

Frequency (MHz)	Emission Level (dBuV/m)	Read Level (dBuV)	Limit (dBuV/m)	Margin (dB)	Antenna Factor (dB/m)	Cable Loss (dB)	Preamp Factor (dB)	Antenna Height (cm)	Table Angle (Degree)	Remark
107.6	34.36	55.32	43.5	-9.14	9.81	1.09	31.86	124	31	Peak
218.18	32.27	52.46	46	-13.73	10.13	1.37	31.69	140	120	Peak
298.69	40.56	57.84	46	-5.44	12.91	1.63	31.82	101	327	Peak
666.32	35.24	44.3	46	-10.76	20.41	2.39	31.86	130	187	Peak
700.27	43.1	51.62	46	-2.9	20.82	2.45	31.79	102	165	QP
900.09	37.29	43.04	46	-8.71	23.51	2.75	32.01	108	181	Peak

Remarks:

- Emission Level = Read Level + Antenna Factor + Cable Loss - Preamp Factor
Margin value = Emission level – Limit value

4.2 Conducted Emission Measurement

4.2.1 Limits of Conducted Emission Measurement

Frequency (MHz)	Conducted Limit (dBuV)	
	Quasi-peak	Average
0.15 - 0.5	66 - 56	56 - 46
0.50 - 5.0	56	46
5.0 - 30.0	60	50

Note: 1. The lower limit shall apply at the transition frequencies.

2. The limit decreases in line with the logarithm of the frequency in the range of 0.15 to 0.50 MHz.

4.2.2 Test Instruments

Description & Manufacturer	Model No.	Serial No.	Date Of Calibration	Due Date Of Calibration
Test Receiver ROHDE & SCHWARZ	ESCI	100613	Nov. 16, 2015	Nov. 15, 2016
RF signal cable (with 10dB PAD) Woken	5D-FB	Cable-cond1-01	Dec. 26, 2015	Dec. 25, 2016
LISN ROHDE & SCHWARZ (EUT)	ESH3-Z5	835239/001	Feb. 26, 2016	Feb. 25, 2017
LISN ROHDE & SCHWARZ (Peripheral)	ESH3-Z5	100311	Jul. 24, 2015	Jul. 23, 2016
Software ADT	BV ADT_Cond_ V7.3.7.3	NA	NA	NA

- Note:**
1. The calibration interval of the above test instruments is 12 months and the calibrations are traceable to NML/ROC and NIST/USA.
 2. The test was performed in HwaYa Shielded Room 1.
 3. The VCCI Site Registration No. is C-2040.

4.2.3 Test Procedures

- a. The EUT was placed 0.4 meters from the conducting wall of the shielded room with EUT being connected to the power mains through a line impedance stabilization network (LISN). Other support units were connected to the power mains through another LISN. The two LISNs provide 50 ohm/ 50uH of coupling impedance for the measuring instrument.
- b. Both lines of the power mains connected to the EUT were checked for maximum conducted interference.
- c. The frequency range from 150 kHz to 30 MHz was searched. Emission levels under (Limit -20 dB) was not recorded.

NOTE: All modes of operation were investigated and the worst-case emissions are reported.

4.2.4 Deviation from Test Standard

No deviation.

4.2.5 Test Setup

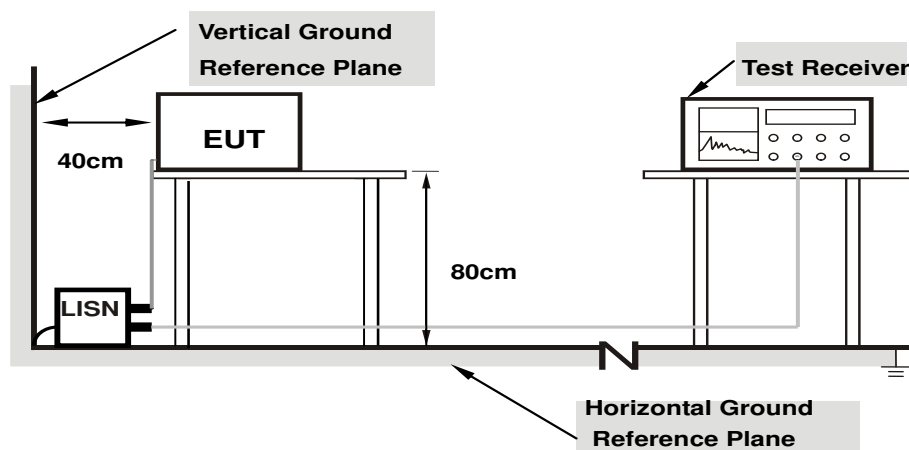

- Note: 1.Support units were connected to second LISN.**
2.Both of LISNs (AMN) are 80 cm from EUT and at least 80 from other units and other metal planes

For the actual test configuration, please refer to the attached file (Test Setup Photo).

4.2.6 EUT Operating Conditions

- a. Placed the EUT on a testing table.
- b. Use the software to control the EUT under transmission condition continuously at specific channel frequency.

4.2.7 Test Results

Frequency Range	150kHz ~ 30MHz	Detector Function & Resolution Bandwidth	Quasi-Peak (QP) / Average (AV), 9kHz
Input Power	120Vac, 60Hz	Environmental Conditions	25°C, 65%RH
Tested by	Toby Tian	Test Date	2016/4/24

Phase Of Power : Line (L)										
No	Frequency (MHz)	Correction Factor (dB)	Reading Value (dBuV)		Emission Level (dBuV)		Limit (dBuV)		Margin (dB)	
			Q.P.	AV.	Q.P.	AV.	Q.P.	AV.	Q.P.	AV.
1	0.15400	10.02	40.74	20.18	50.76	30.20	65.78	55.78	-15.03	-25.59
2	0.20201	10.03	40.34	22.81	50.37	32.84	63.53	53.53	-13.16	-20.69
3	0.24614	10.05	30.56	15.87	40.61	25.92	61.89	51.89	-21.28	-25.97
4	0.46200	10.13	20.10	11.53	30.23	21.66	56.66	46.66	-26.43	-25.00
5	2.02600	10.27	16.15	8.14	26.42	18.41	56.00	46.00	-29.58	-27.59
6	3.71800	10.39	16.74	9.59	27.13	19.98	56.00	46.00	-28.87	-26.02

Remarks:

1. Q.P. and AV. are abbreviations of quasi-peak and average individually.
2. The emission levels of other frequencies were very low against the limit.
3. Margin value = Emission level – Limit value
4. Correction factor = Insertion loss + Cable loss
5. Emission Level = Correction Factor + Reading Value

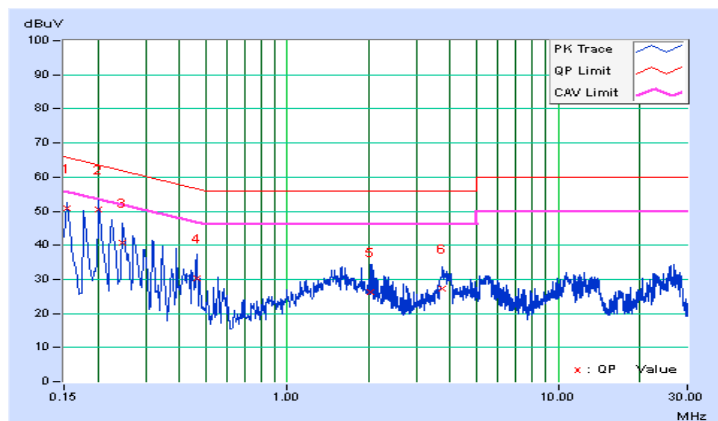

Frequency Range	150kHz ~ 30MHz	Detector Function & Resolution Bandwidth	Quasi-Peak (QP) / Average (AV), 9kHz
Input Power	120Vac, 60Hz	Environmental Conditions	25°C, 65%RH
Tested by	Toby Tian	Test Date	2016/4/24

Phase Of Power : Neutral (N)										
No	Frequency (MHz)	Correction Factor (dB)	Reading Value (dBuV)		Emission Level (dBuV)		Limit (dBuV)		Margin (dB)	
			Q.P.	AV.	Q.P.	AV.	Q.P.	AV.	Q.P.	AV.
1	0.15800	10.03	39.27	19.30	49.30	29.33	65.57	55.57	-16.27	-26.24
2	0.18600	10.04	39.17	21.29	49.21	31.33	64.21	54.21	-15.01	-22.89
3	0.23400	10.06	30.59	14.92	40.65	24.98	62.31	52.31	-21.66	-27.33
4	0.42200	10.13	19.55	8.51	29.68	18.64	57.41	47.41	-27.73	-28.77
5	1.87400	10.27	15.45	7.92	25.72	18.19	56.00	46.00	-30.28	-27.81
6	14.08600	11.05	16.63	9.78	27.68	20.83	60.00	50.00	-32.32	-29.17

Remarks:

1. Q.P. and AV. are abbreviations of quasi-peak and average individually.
2. The emission levels of other frequencies were very low against the limit.
3. Margin value = Emission level – Limit value
4. Correction factor = Insertion loss + Cable loss
5. Emission Level = Correction Factor + Reading Value

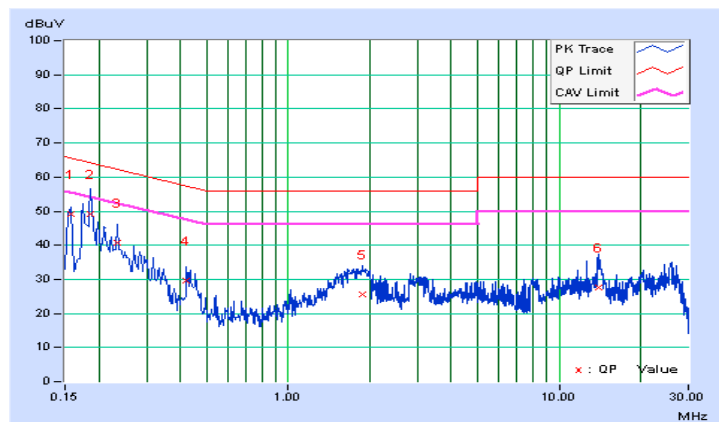

4.3 Transmit Power Measurement

4.3.1 Limits of Transmit Power Measurement

Operation Band	EUT Category	Limit
U-NII-1	Outdoor Access Point	1 Watt (30 dBm) (Max. e.i.r.p \leq 125 mW (21 dBm) at any elevation angle above 30 degrees as measured from the horizon)
	Fixed point-to-point Access Point	1 Watt (30 dBm)
	Indoor Access Point	1 Watt (30 dBm)
	√ Mobile and Portable client device	250 mW (24 dBm)
U-NII-2A	√	250 mW (24 dBm) or 11 dBm+10 log B*
U-NII-2C	√	250 mW (24 dBm) or 11 dBm+10 log B*
U-NII-3	√	1 Watt (30 dBm)

*B is the 26 dB emission bandwidth in megahertz

Per KDB 662911 Method of conducted output power measurement on IEEE 802.11 devices,

Array Gain = 0 dB (i.e., no array gain) for $N_{ANT} \leq 4$;

Array Gain = 0 dB (i.e., no array gain) for channel widths ≥ 40 MHz for any N_{ANT} ;

Array Gain = $5 \log(N_{ANT}/N_{SS})$ dB or 3 dB, whichever is less for 20 MHz channel widths with $N_{ANT} \geq 5$.

For power measurements on all other devices: Array Gain = $10 \log(N_{ANT}/N_{SS})$ dB.

4.3.2 Test Setup

<Power Output Measurement>

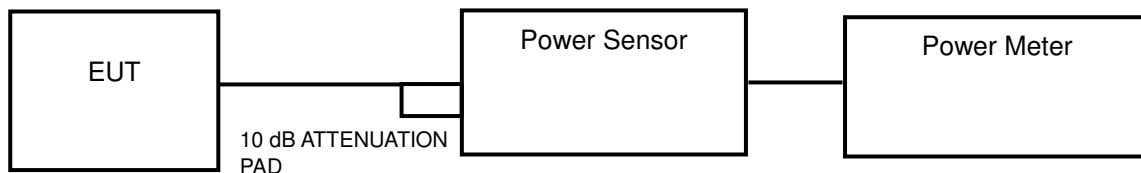

or



<26 dB Bandwidth>

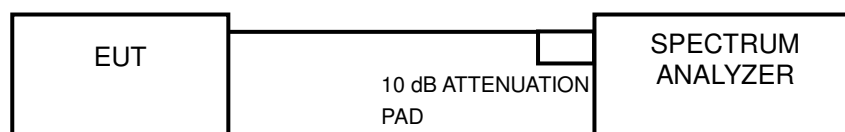

4.3.3 Test Instruments

Refer to section 4.1.2 to get information of above instrument.

4.3.4 Test Procedure

Average Power Measurement

<802.11a, 802.11n (HT20), 802.11n (HT40)>

Method PM is used to perform output power measurement, trigger and gating function of wide band power meter is enabled to measure max output power of TX on burst. Duty factor is not added to measured value.

<802.11ac (VHT80)>

Method SA-1 is used to perform output power measurement, trigger and gating function of spectrum analyzer is enabled to measure max output power of TX on burst. Duty factor is not added to measured value.

26 dB Bandwidth

- 1) Set RBW = approximately 1 % of the emission bandwidth.
- 2) Set the VBW > RBW.
- 3) Detector = Peak.
- 4) Trace mode = max hold.
- 5) Measure the maximum width of the emission that is 26 dB down from the peak of the emission. Compare this with the RBW setting of the analyzer. Readjust RBW and repeat measurement as needed until the RBW/EBW ratio is approximately 1 %.

4.3.5 Deviation from Test Standard

No deviation.

4.3.6 EUT Operating Conditions

The software provided by client to enable the EUT under transmission condition continuously at lowest, middle and highest channel frequencies individually.

4.3.7 Test Result

Power Output:

MODE A (1TX)

802.11a

Channel	Frequency (MHz)	Maximum Conducted Power (mW)	Maximum Conducted Power (dBm)	Power Limit (dBm)	Pass / Fail
36	5180	38.82	15.89	24	Pass
44	5220	39.36	15.95	24	Pass
48	5240	38.19	15.82	24	Pass
52	5260	37.41	15.73	24	Pass
60	5300	37.67	15.76	24	Pass
64	5320	36.90	15.67	24	Pass
100	5500	39.17	15.93	24	Pass
116	5580	39.45	15.96	24	Pass
140	5700	38.55	15.86	24	Pass
149	5745	38.02	15.8	30	Pass
157	5785	38.28	15.83	30	Pass
165	5825	37.93	15.79	30	Pass

Note:

For U-NII-2A, U-NII-2C Band:

1. $11 \text{ dBm} + 10\log(23.42) = 26.69 \text{ dBm} > 24 \text{ dBm}$.
2. $11 \text{ dBm} + 10\log(23.95) = 26.68 \text{ dBm} > 24 \text{ dBm}$.
3. $11 \text{ dBm} + 10\log(23.67) = 26.69 \text{ dBm} > 24 \text{ dBm}$.
4. $11 \text{ dBm} + 10\log(24.06) = 26.68 \text{ dBm} > 24 \text{ dBm}$.
5. $11 \text{ dBm} + 10\log(23.52) = 26.69 \text{ dBm} > 24 \text{ dBm}$.
6. $11 \text{ dBm} + 10\log(22.47) = 23.46 \text{ dBm} > 24 \text{ dBm}$.

MODE B (3TX)
802.11n (HT20)

Channel	Frequency (MHz)	Maximum Cunducted Power (dBm)			Total Power (mW)	Total Power (dBm)	Power Limit (dBm)	Pass / Fail
		Chain 0	Chain 1	Chain 2				
36	5180	14.54	14.03	13.15	74.39	18.72	24	Pass
44	5220	14.26	13.77	12.93	70.13	18.46	24	Pass
48	5240	14.11	13.85	12.96	69.80	18.44	24	Pass
52	5260	13.85	14.07	13.22	70.78	18.50	24	Pass
60	5300	13.54	13.52	13.15	65.74	18.18	24	Pass
64	5320	13.62	13.62	13.24	67.12	18.27	24	Pass
100	5500	12.89	12.11	11.72	50.57	17.04	24	Pass
116	5580	13.84	12.78	12.16	59.62	17.75	24	Pass
140	5700	15.50	14.25	13.05	82.27	19.15	24	Pass
149	5745	16.03	14.55	15.24	102.016	20.09	30	Pass
157	5785	16.52	15.43	16.35	122.940	20.90	30	Pass
165	5825	15.96	15.38	17.27	127.294	21.05	30	Pass

Note:

For U-NII-2A, U-NII-2C Band:

Chain 0

1. $11 \text{ dBm} + 10\log(23.69) = 24.75 \text{ dBm} > 24 \text{ dBm}$.
2. $11 \text{ dBm} + 10\log(23.98) = 24.80 \text{ dBm} > 24 \text{ dBm}$.
3. $11 \text{ dBm} + 10\log(23.67) = 24.74 \text{ dBm} > 24 \text{ dBm}$.
4. $11 \text{ dBm} + 10\log(23.72) = 24.75 \text{ dBm} > 24 \text{ dBm}$.
5. $11 \text{ dBm} + 10\log(23.52) = 24.71 \text{ dBm} > 24 \text{ dBm}$.
6. $11 \text{ dBm} + 10\log(24.04) = 24.81 \text{ dBm} > 24 \text{ dBm}$.

Chain 1

1. $11 \text{ dBm} + 10\log(24.43) = 24.88 \text{ dBm} > 24 \text{ dBm}$.
2. $11 \text{ dBm} + 10\log(24.09) = 24.82 \text{ dBm} > 24 \text{ dBm}$.
3. $11 \text{ dBm} + 10\log(23.86) = 24.78 \text{ dBm} > 24 \text{ dBm}$.
4. $11 \text{ dBm} + 10\log(23.26) = 24.67 \text{ dBm} > 24 \text{ dBm}$.
5. $11 \text{ dBm} + 10\log(23.78) = 24.76 \text{ dBm} > 24 \text{ dBm}$.
6. $11 \text{ dBm} + 10\log(23.59) = 24.73 \text{ dBm} > 24 \text{ dBm}$.

Chain 2

1. $11 \text{ dBm} + 10\log(23.91) = 24.79 \text{ dBm} > 24 \text{ dBm}$.
2. $11 \text{ dBm} + 10\log(24.70) = 24.93 \text{ dBm} > 24 \text{ dBm}$.
3. $11 \text{ dBm} + 10\log(23.90) = 24.78 \text{ dBm} > 24 \text{ dBm}$.
4. $11 \text{ dBm} + 10\log(23.22) = 24.66 \text{ dBm} > 24 \text{ dBm}$.
5. $11 \text{ dBm} + 10\log(23.52) = 24.71 \text{ dBm} > 24 \text{ dBm}$.
6. $11 \text{ dBm} + 10\log(24.38) = 24.87 \text{ dBm} > 24 \text{ dBm}$.

802.11n (HT40)

Channel	Frequency (MHz)	Maximum Conducted Power (dBm)			Total Power (mW)	Total Power (dBm)	Power Limit (dBm)	Pass / Fail
		Chain 0	Chain 1	Chain 2				
38	5190	11.38	11.28	10.95	39.61	15.98	24	Pass
46	5230	15.91	15.51	16.90	123.54	20.92	24	Pass
54	5270	16.05	15.58	16.42	120.27	20.80	24	Pass
62	5310	13.19	13.46	13.03	63.12	18.00	24	Pass
102	5510	14.59	14.21	14.11	80.90	19.08	24	Pass
110	5550	15.79	14.75	14.66	97.03	19.87	24	Pass
134	5670	16.46	15.93	15.60	119.74	20.78	24	Pass
151	5755	14.72	14.05	13.09	75.428	18.78	30	Pass
159	5795	15.96	16.28	16.08	122.459	20.88	30	Pass

Note:

For U-NII-2A, U-NII-2C Band:

Chain 0

1. $11 \text{ dBm} + 10\log(49.98) = 27.99 \text{ dBm} > 24 \text{ dBm}$.
2. $11 \text{ dBm} + 10\log(48.22) = 27.83 \text{ dBm} > 24 \text{ dBm}$.
3. $11 \text{ dBm} + 10\log(48.11) = 27.82 \text{ dBm} > 24 \text{ dBm}$.
4. $11 \text{ dBm} + 10\log(50.35) = 28.02 \text{ dBm} > 24 \text{ dBm}$.
5. $11 \text{ dBm} + 10\log(47.88) = 27.80 \text{ dBm} > 24 \text{ dBm}$.

Chain 1

1. $11 \text{ dBm} + 10\log(46.67) = 27.69 \text{ dBm} > 24 \text{ dBm}$.
2. $11 \text{ dBm} + 10\log(46.06) = 27.63 \text{ dBm} > 24 \text{ dBm}$.
3. $11 \text{ dBm} + 10\log(47.21) = 27.74 \text{ dBm} > 24 \text{ dBm}$.
4. $11 \text{ dBm} + 10\log(47.26) = 27.74 \text{ dBm} > 24 \text{ dBm}$.
5. $11 \text{ dBm} + 10\log(47.65) = 27.78 \text{ dBm} > 24 \text{ dBm}$.

Chain 2

1. $11 \text{ dBm} + 10\log(48.14) = 27.83 \text{ dBm} > 24 \text{ dBm}$.
2. $11 \text{ dBm} + 10\log(47.78) = 27.79 \text{ dBm} > 24 \text{ dBm}$.
3. $11 \text{ dBm} + 10\log(47.71) = 27.79 \text{ dBm} > 24 \text{ dBm}$.
4. $11 \text{ dBm} + 10\log(47.00) = 27.72 \text{ dBm} > 24 \text{ dBm}$.
5. $11 \text{ dBm} + 10\log(47.95) = 27.81 \text{ dBm} > 24 \text{ dBm}$.

802.11ac (VHT80)

Channel	Frequency (MHz)	Maximum Conducted Power (dBm)			Total Power (mW)	Total Power (dBm)	Power Limit (dBm)	Pass / Fail
		Chain 0	Chain 1	Chain 2				
42	5210	8.51	7.85	9.83	22.81	13.58	24	Pass
58	5290	8.63	8.26	10.13	24.30	13.86	24	Pass
106	5530	10.47	10.25	10.67	33.40	15.24	24	Pass
122	5610	16.53	15.78	15.81	120.93	20.83	24	Pass
155	5775	11.96	11.08	11.67	43.216	16.36	30	Pass

Note:

For U-NII-2A, U-NII-2C Band:

Chain 0

1. 11 dBm + 10log (87.91) = 30.44 dBm > 24 dBm.
2. 11 dBm + 10log (85.90) = 30.34 dBm > 24 dBm.
3. 11 dBm + 10log (101.17) = 31.05 dBm > 24 dBm.

Chain 1

1. 11 dBm + 10log (86.74) = 30.38 dBm > 24 dBm.
2. 11 dBm + 10log (86.33) = 30.36 dBm > 24 dBm.
3. 11 dBm + 10log (95.50) = 30.80 dBm > 24 dBm.

Chain 2

1. 11 dBm + 10log (87.61) = 30.43 dBm > 24 dBm.
2. 11 dBm + 10log (90.57) = 30.57 dBm > 24 dBm.
3. 11 dBm + 10log (92.39) = 30.66 dBm > 24 dBm.

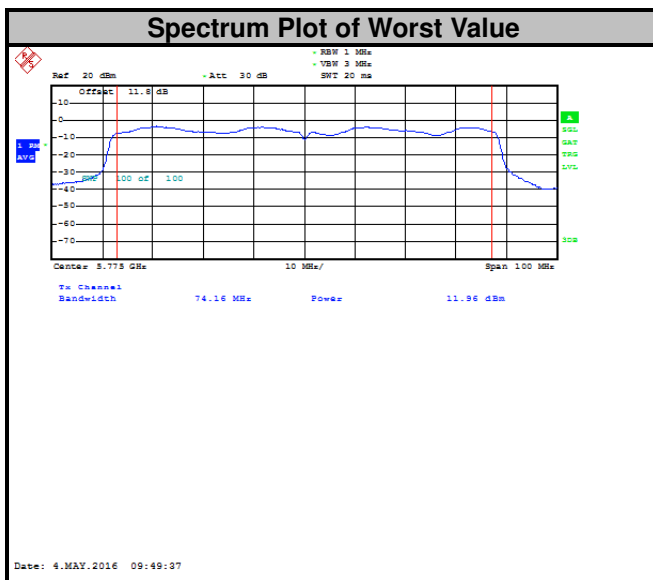

26 dB Bandwidth:
MODE A (1TX)
802.11a

Channel	Frequency (MHz)	26 dBc Bandwidth (MHz)
36	5180	23.84
44	5220	22.86
48	5240	23.68
52	5260	23.42
60	5300	23.95
64	5320	23.67
100	5500	24.06
116	5580	23.52
140	5700	22.47

MODE B (3TX)
802.11n (HT20)

Channel	Frequency (MHz)	26 dBc Bandwidth (MHz)		
		Chain 0	Chain 1	Chain 2
36	5180	23.16	24.53	24.48
44	5220	23.62	23.34	24.47
48	5240	23.55	23.79	24.00
52	5260	23.69	24.43	23.91
60	5300	23.98	24.09	24.70
64	5320	23.67	23.86	23.90
100	5500	23.72	23.26	23.22
116	5580	23.52	23.78	23.52
140	5700	24.04	23.59	24.38

802.11n (HT40)

Channel	Frequency (MHz)	26 dBc Bandwidth (MHz)		
		Chain 0	Chain 1	Chain 2
38	5190	47.23	48.00	46.32
46	5230	48.06	47.47	47.84
54	5270	49.98	46.67	48.14
62	5310	48.22	46.06	47.78
102	5510	48.11	47.21	47.71
110	5550	50.35	47.26	47.00
134	5670	47.88	47.65	47.95

802.11ac (VHT80)

Channel	Frequency (MHz)	26 dBc Bandwidth (MHz)		
		Chain 0	Chain 1	Chain 2
42	5210	89.30	88.79	90.06
58	5290	87.91	86.74	87.61
106	5530	85.90	86.33	90.57
122	5610	101.17	95.50	92.39

Spectrum Plot of Worst Value

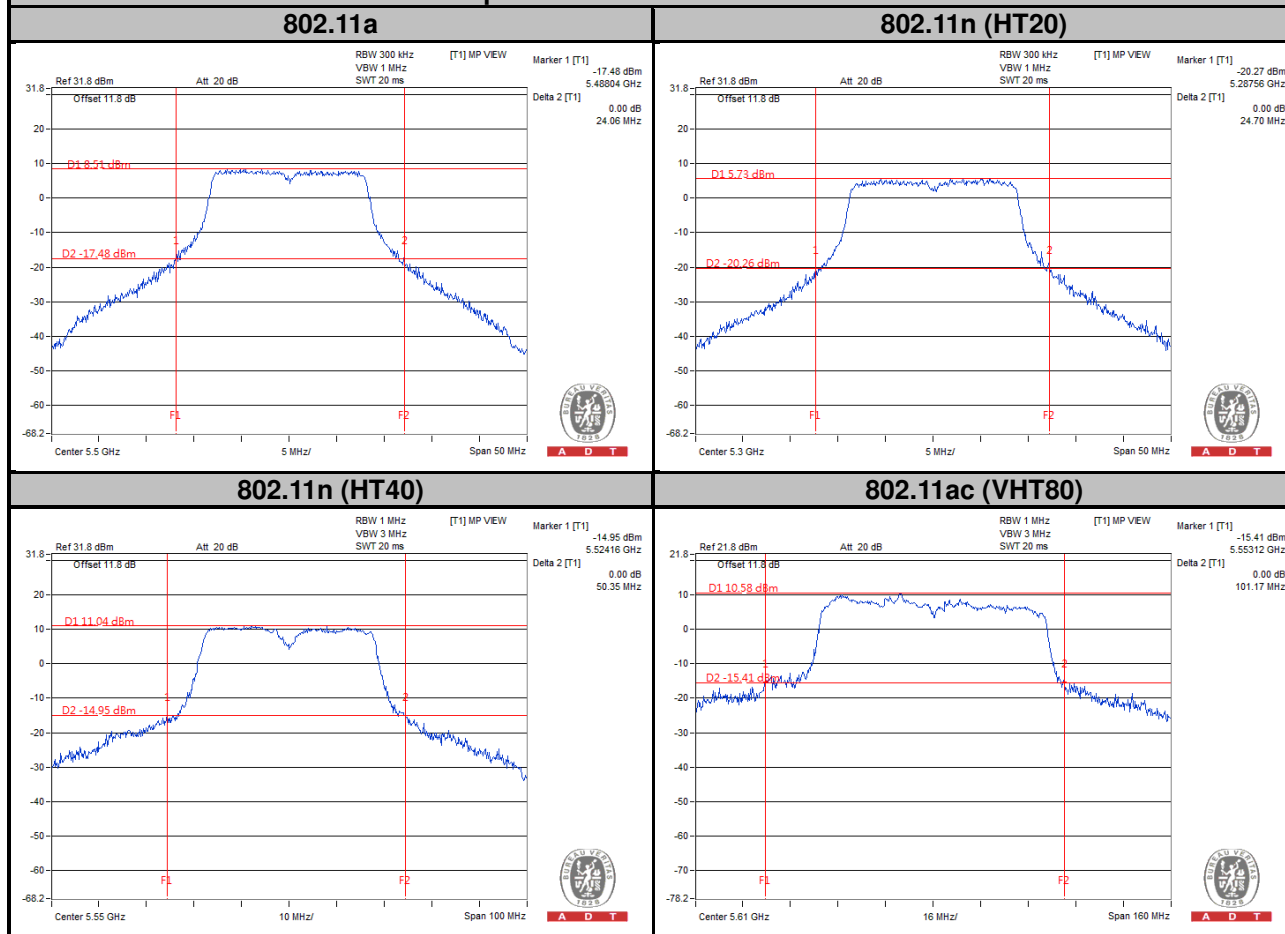

4.4 Peak Power Spectral Density Measurement

4.4.1 Limits of Peak Power Spectral Density Measurement

Operation Band	EUT Category		Limit
U-NII-1		Outdoor Access Point	17 dBm/MHz
		Fixed point-to-point Access Point	
		Indoor Access Point	
	√	Mobile and Portable client device	11 dBm/MHz
U-NII-2A		√	11 dBm/MHz
U-NII-2C		√	11 dBm/MHz
U-NII-3		√	30 dBm/500 kHz

4.4.2 Test Setup

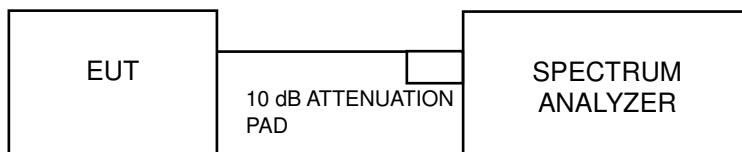

4.4.3 Test Instruments

Refer to section 4.1.3 to get information of above instrument.

4.4.4 Test Procedures

For U-NII-1, U-NII-2A, U-NII-2C band:

Using method SA-2

1. Set span to encompass the entire emission bandwidth (EBW) of the signal.
2. Set RBW = 1 MHz, Set VBW \geq 3 RBW, Detector = RMS
3. Sweep time = auto, trigger set to "free run".
4. Trace average at least 100 traces in power averaging mode.
5. Record the max value and add 10 log (1/duty cycle)

※For U-NII-3:

1. Set span to encompass the entire emission bandwidth (EBW) of the signal.
2. Set RBW = 500 kHz, Set VBW \geq 3 RBW, Detector = RMS
3. Use the peak marker function to determine the maximum power level in any 500 kHz band segment within the fundamental EBW.
4. Sweep time = auto, trigger set to "free run".
5. Trace average at least 100 traces in power averaging mode.
6. Record the max value and add 10 log (1/duty cycle)

4.4.5 Deviation from Test Standard

No deviation.

4.4.6 EUT Operating Conditions

The software provided by client to enable the EUT under transmission condition continuously at lowest, middle and highest channel frequencies individually.

4.4.7 Test Results

For U-NII-1, U-NII-2A, U-NII-2C Band

MODE A (1TX)

802.11a

Channel	Frequency (MHz)	PSD w/o Duty Factor (dBm)	Duty Factor	PSD with Duty Factor (dBm)	Maximum Limit (dBm)	Pass / Fail
36	5180	2.98	0.18	3.16	11	Pass
44	5220	3.34	0.18	3.52	11	Pass
48	5240	3.17	0.18	3.35	11	Pass
52	5260	3.19	0.18	3.37	11	Pass
60	5300	3.55	0.18	3.73	11	Pass
64	5320	3.76	0.18	3.94	11	Pass
100	5500	5.06	0.18	5.24	11	Pass
116	5580	4.65	0.18	4.83	11	Pass
140	5700	3.30	0.18	3.48	11	Pass

Note: Refer to section 3.3 for duty cycle spectrum plot.

MODE B (3TX)
802.11n (HT20)

Channel	Frequency (MHz)	PSD (dBm)			Total PSD w/o Duty Factor (dBm)	Duty Factor	Total PSD with Duty Factor (dBm)	Maximum Limit (dBm)	Pass / Fail
		Chain 0	Chain 1	Chain 2					
36	5180	1.53	0.68	3.24	6.72	0.19	6.91	7.23	Pass
44	5220	1.06	0.68	1.32	5.80	0.19	5.98	7.23	Pass
48	5240	1.24	0.84	2.82	6.49	0.19	6.68	7.23	Pass
52	5260	1.34	1.23	1.66	6.19	0.19	6.38	7.23	Pass
60	5300	0.74	0.79	2.16	6.05	0.19	6.24	7.23	Pass
64	5320	1.12	1.15	2.40	6.37	0.19	6.56	7.23	Pass
100	5500	3.44	1.73	0.89	6.92	0.19	7.11	7.23	Pass
116	5580	3.08	2.21	1.25	7.02	0.19	7.21	7.23	Pass
140	5700	2.21	1.81	1.50	6.62	0.19	6.81	7.23	Pass

Note:

- Method 1 of power density measurement of KDB 662911 is using for calculating total power density. Total power density is summing entire spectra across corresponding frequency bins on the various outputs by computer.
- For U-NII-1, U-NII-2A, U-NII-2C Band:**
 Directional gain = $5 \text{ dBi} + 10\log(3) = 9.77 \text{ dBi} > 6 \text{ dBi}$, so the power density limit shall be reduced to $11 - (9.77 - 6) = 7.23 \text{ dBm}$.
- Refer to section 3.3 for duty cycle spectrum plot.

802.11n (HT40)

Channel	Frequency (MHz)	PSD (dBm)			Total PSD w/o Duty Factor (dBm)	Duty Factor	Total PSD with Duty Factor (dBm)	Maximum Limit (dBm)	Pass / Fail
		Chain 0	Chain 1	Chain 2					
38	5190	-3.60	-4.44	-4.63	0.57	0.52	1.09	7.23	Pass
46	5230	0.88	-0.22	1.48	5.54	0.52	6.06	7.23	Pass
54	5270	1.07	0.53	1.51	5.83	0.52	6.35	7.23	Pass
62	5310	-1.88	-1.73	-0.41	3.48	0.52	4.00	7.23	Pass
102	5510	2.65	1.65	1.26	6.66	0.52	7.18	7.23	Pass
110	5550	2.15	0.89	1.56	6.33	0.52	6.85	7.23	Pass
134	5670	1.46	1.60	1.13	6.17	0.52	6.69	7.23	Pass

Note:

- Method 1 of power density measurement of KDB 662911 is using for calculating total power density. Total power density is summing entire spectra across corresponding frequency bins on the various outputs by computer.
- For U-NII-1, U-NII-2A, U-NII-2C Band:**
 Directional gain = 5 dBi + 10log(3) = 9.77 dBi > 6 dBi , so the power density limit shall be reduced to 11-(9.77-6) = 7.23 dBm.
- Refer to section 3.3 for duty cycle spectrum plot.

802.11ac (VHT80)

Channel	Frequency (MHz)	PSD (dBm)			Total PSD w/o Duty Factor (dBm)	Duty Factor	Total PSD with Duty Factor (dBm)	Maximum Limit (dBm)	Pass / Fail
		Chain 0	Chain 1	Chain 2					
42	5210	-10.08	-10.40	-8.68	-4.88	0.89	-3.99	7.23	Pass
58	5290	-10.01	-10.08	-10.28	-5.35	0.89	-4.46	7.23	Pass
106	5530	-6.57	-8.22	-7.90	-2.73	0.89	-1.84	7.23	Pass
122	5610	-0.65	-2.41	-3.36	2.78	0.89	3.67	7.23	Pass

Note:

- Method 1 of power density measurement of KDB 662911 is using for calculating total power density. Total power density is summing entire spectra across corresponding frequency bins on the various outputs by computer.
- For U-NII-1, U-NII-2A, U-NII-2C Band:**
 Directional gain = 5 dBi + 10log(3) = 9.77 dBi > 6 dBi , so the power density limit shall be reduced to 11-(9.77-6) = 7.23 dBm.
- Refer to section 3.3 for duty cycle spectrum plot.

Spectrum Plot of Worst Value

802.11a

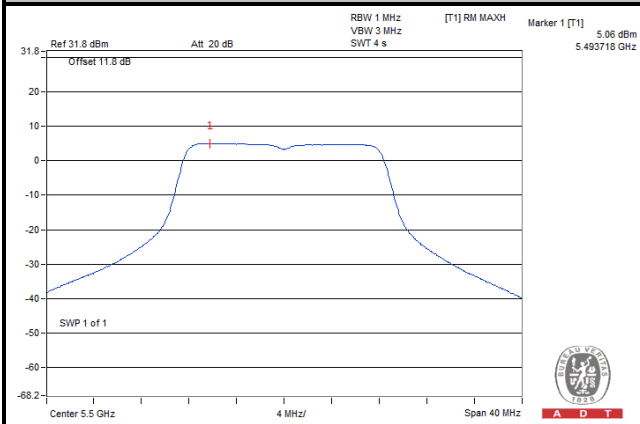

802.11n (HT20)

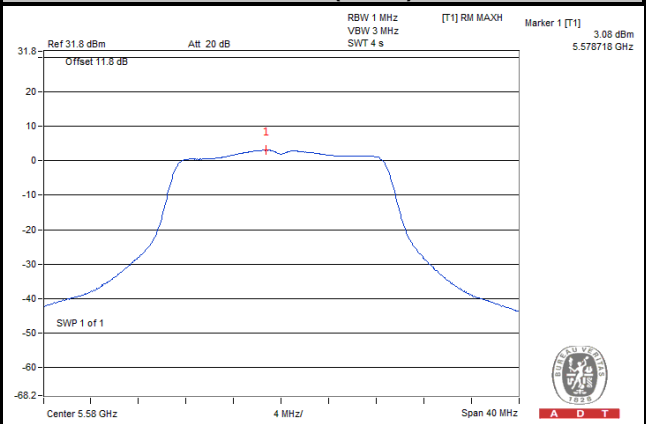

802.11n (HT40)

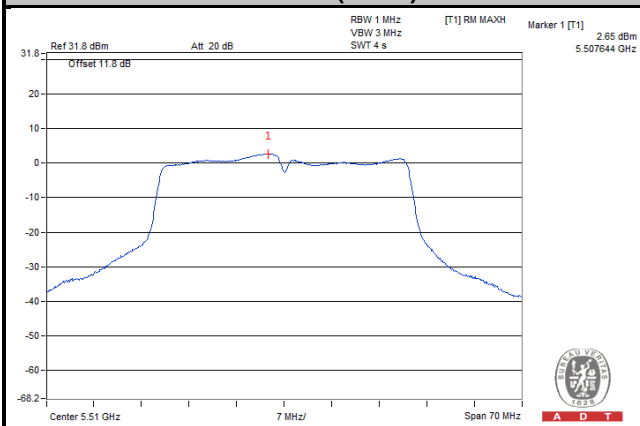

802.11ac (VHT80)

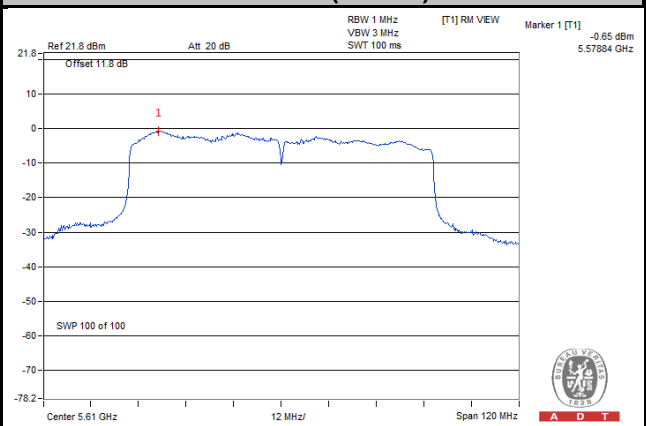

For U-NII-3 Band

MODE A (1TX)

802.11a

Channel	Frequency (MHz)	PSD w/o Duty Factor (dBm)	Duty Factor	PSD with Duty Factor (dBm)	Limit (dBm/500 kHz)	Pass / Fail
149	5745	0.15	0.18	0.33	30	Pass
157	5785	-0.13	0.18	0.05	30	Pass
165	5825	0.50	0.18	0.68	30	Pass

Note: Refer to section 3.3 for duty cycle spectrum plot.

MODE B (3TX)

802.11n (HT20)

TX Chain	Channel	Frequency (MHz)	PSD (dBm/500 kHz)	10 log (N=3) dB	Total PSD without Duty Factor (dBm/500 kHz)	Duty Factor	Total PSD with Duty Factor (dBm/500 kHz)	Limit (dBm/500 kHz)	Pass / Fail
0	149	5745	1.08	4.77	5.85	0.19	6.04	26.23	Pass
	157	5785	1.67	4.77	6.44	0.19	6.63	26.23	Pass
	165	5825	1.67	4.77	6.44	0.19	6.63	26.23	Pass
1	149	5745	-0.08	4.77	4.69	0.19	4.88	26.23	Pass
	157	5785	0.02	4.77	4.79	0.19	4.98	26.23	Pass
	165	5825	0.01	4.77	4.78	0.19	4.97	26.23	Pass
2	149	5745	0.27	4.77	5.04	0.19	5.23	26.23	Pass
	157	5785	1.20	4.77	5.97	0.19	6.16	26.23	Pass
	165	5825	2.66	4.77	7.43	0.19	7.62	26.23	Pass

Note:

- Method 1 of power density measurement of KDB 662911 is using for calculating total power density. Total power density is summing entire spectra across corresponding frequency bins on the various outputs by computer.
- Directional gain = 5 dBi + 10log(3) = 9.77 dBi > 6 dBi , so the power density limit shall be reduced to 30-(9.77-6) = 26.23 dBm.
- Refer to section 3.3 for duty cycle spectrum plot.

802.11n (HT40)

TX Chain	Channel	Frequency (MHz)	PSD (dBm/500 kHz)	10 log (N=3) dB	Total PSD without Duty Factor (dBm/500 kHz)	Duty Factor	Total PSD with Duty Factor (dBm/500 kHz)	Limit (dBm/500 kHz)	Pass / Fail
0	151	5755	-3.12	4.77	1.65	0.52	2.17	26.23	Pass
	159	5795	-1.26	4.77	3.51	0.52	4.03	26.23	Pass
1	151	5755	-3.31	4.77	1.46	0.52	1.98	26.23	Pass
	159	5795	-1.73	4.77	3.04	0.52	3.56	26.23	Pass
2	151	5755	-3.58	4.77	1.19	0.52	1.71	26.23	Pass
	159	5795	-1.24	4.77	3.53	0.52	4.05	26.23	Pass

Note:

- Method 1 of power density measurement of KDB 662911 is using for calculating total power density. Total power density is summing entire spectra across corresponding frequency bins on the various outputs by computer.
- Directional gain = 5 dBi + 10log(3) = 9.77 dBi > 6 dBi , so the power density limit shall be reduced to 30-(9.77-6) = 26.23 dBm.
- Refer to section 3.3 for duty cycle spectrum plot.

802.11ac (VHT80)

TX Chain	Channel	Frequency (MHz)	PSD (dBm/500 kHz)	10 log (N=3) dB	Total PSD without Duty Factor (dBm/500 kHz)	Duty Factor	Total PSD with Duty Factor (dBm/500 kHz)	Limit (dBm/500 kHz)	Pass / Fail
0	155	5775	-8.12	4.77	-3.35	0.89	-2.46	26.23	Pass
1	155	5775	-8.57	4.77	-3.80	0.89	-2.91	26.23	Pass
2	155	5775	-8.04	4.77	-3.27	0.89	-2.38	26.23	Pass

Note:

- Method 1 of power density measurement of KDB 662911 is using for calculating total power density. Total power density is summing entire spectra across corresponding frequency bins on the various outputs by computer.
- Directional gain = 5 dBi + 10log(3) = 9.77 dBi > 6 dBi , so the power density limit shall be reduced to 30-(9.77-6) = 26.23 dBm.
- Refer to section 3.3 for duty cycle spectrum plot.

Spectrum Plot of Worst Value

802.11a

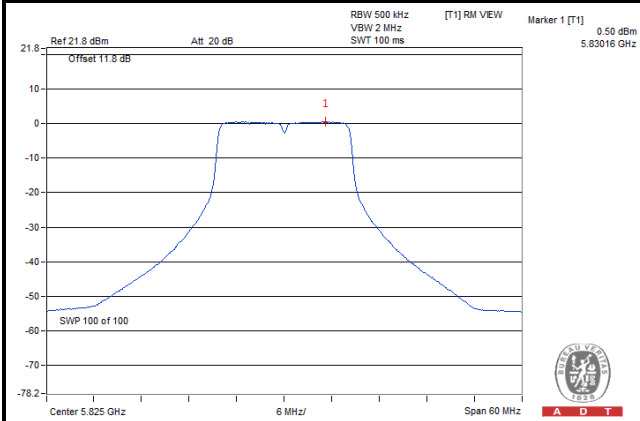

802.11n (HT20)

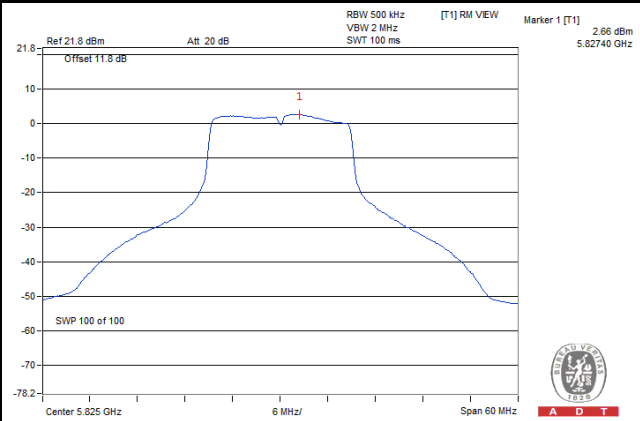

802.11n (HT40)

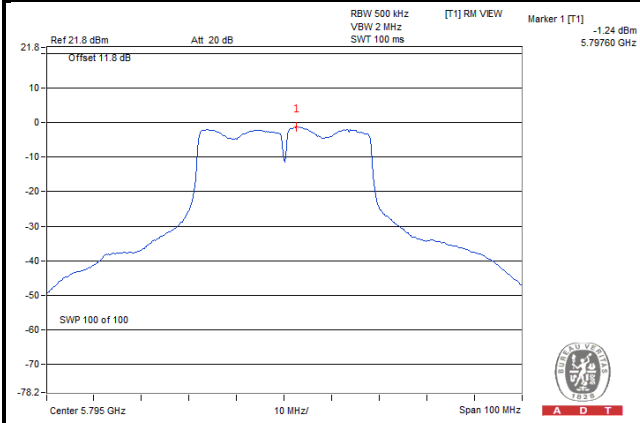

802.11ac (VHT80)

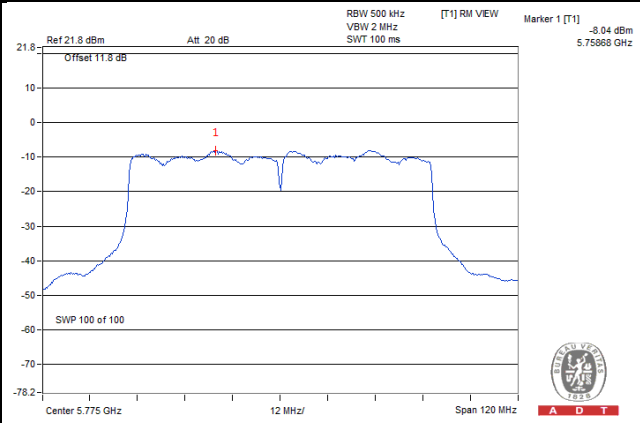

4.5 Frequency Stability

4.5.1 Limit of Frequency Stability Measurement

The frequency of the carrier signal shall be maintained within band of operation.

4.5.2 Test Setup

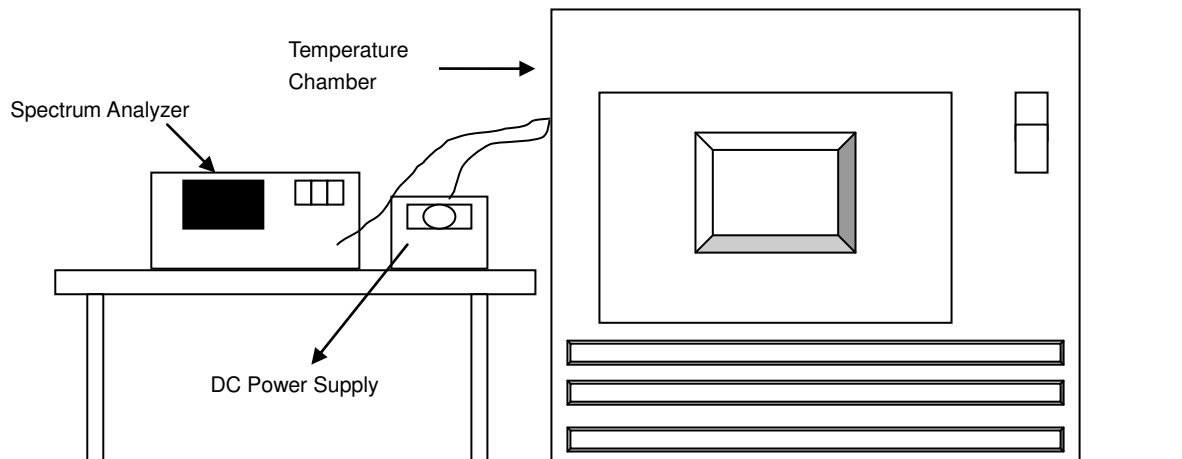

4.5.3 Test Instruments

Refer to section 4.1.3 to get information of above instrument.

4.5.4 Test Procedure

- To ensure emission at the band edge is maintained within the authorized band, those values shall be measured by radiation emissions at upper and lower frequency points, and finally compensated by frequency deviation as procedures below.
- The EUT was operated at the maximum output power, and connected to the spectrum analyzer, which is set to maximum hold function and peak detector. The peak value of the power envelope was measured and noted. The upper and lower frequency points were respectively measured relatively 10 dB lower than the measured peak value.
- The frequency deviation was calculated by adding the upper frequency point and the lower frequency point divided by two. Those detailed values of frequency deviation are provided in table below.

4.5.5 Deviation from Test Standard

No deviation.

4.5.6 EUT Operating Condition

Set the EUT transmit at un-modulation mode to test frequency stability.

4.5.7 Test Results

Frequency Stability Versus Temp.									
Operating Frequency: 5320 MHz									
Temp. (°C)	Power Supply (Vdc)	0 Minute		2 Minute		5 Minute		10 Minute	
		Measured Frequency (MHz)	Frequency Drift (ppm)	Measured Frequency (MHz)	Frequency Drift (ppm)	Measured Frequency (MHz)	Frequency Drift (ppm)	Measured Frequency (MHz)	Frequency Drift (ppm)
85	3.3	5320.011813	2.220	5320.011790	2.216	5320.011467	2.155	5320.011177	2.101
80	3.3	5320.012190	2.291	5320.012620	2.372	5320.012266	2.306	5320.012715	2.390
70	3.3	5320.012306	2.313	5320.012549	2.359	5320.012439	2.338	5320.012206	2.294
60	3.3	5320.012163	2.286	5320.012000	2.256	5320.012300	2.312	5320.012163	2.286
50	3.3	5320.011884	2.234	5320.011773	2.213	5320.012283	2.309	5320.011904	2.238
40	3.3	5320.011872	2.232	5320.012293	2.311	5320.012418	2.334	5320.012161	2.286
30	3.3	5320.013411	2.521	5320.013417	2.522	5320.013714	2.578	5320.013940	2.620
20	3.3	5320.014613	2.747	5320.014046	2.640	5320.014180	2.665	5320.014732	2.769
10	3.3	5320.015817	2.973	5320.015411	2.897	5320.015753	2.961	5320.015820	2.974
0	3.3	5320.014760	2.774	5320.014566	2.738	5320.014698	2.763	5320.014839	2.789
-10	3.3	5320.012940	2.432	5320.012603	2.369	5320.012777	2.402	5320.012742	2.395
-20	3.3	5320.012490	2.348	5320.012405	2.332	5320.012440	2.338	5320.012884	2.422
-30	3.3	5320.011308	2.126	5320.011155	2.097	5320.011347	2.133	5320.011358	2.135
-40	3.3	5320.011360	2.135	5320.011477	2.157	5320.011283	2.121	5320.011531	2.167

Frequency Stability Versus Temp.									
Operating Frequency: 5320 MHz									
Temp. (°C)	Power Supply (Vdc)	0 Minute		2 Minute		5 Minute		10 Minute	
		Measured Frequency (MHz)	Frequency Drift (ppm)	Measured Frequency (MHz)	Frequency Drift (ppm)	Measured Frequency (MHz)	Frequency Drift (ppm)	Measured Frequency (MHz)	Frequency Drift (ppm)
20	3.14	5320.020198	3.797	5320.020359	3.827	5320.020543	3.861	5320.020231	3.803
	3.3	5320.014613	2.747	5320.014046	2.640	5320.014180	2.665	5320.014732	2.769
	3.47	5320.021813	4.100	5320.021677	4.075	5320.021717	4.082	5320.022090	4.152

4.6 6 dB Bandwidth Measurement

4.6.1 Limits of 6 dB Bandwidth Measurement

The minimum of 6 dB Bandwidth Measurement is 0.5 MHz.

4.6.2 Test Setup

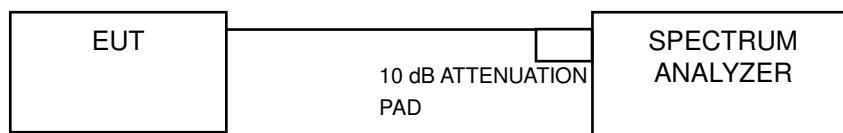

4.6.3 Test Instruments

Refer to section 4.1.3 to get information of above instrument.

4.6.4 Test Procedure

MEASUREMENT PROCEDURE REF

- Set resolution bandwidth (RBW) = 100 kHz
- Set the video bandwidth (VBW) $\geq 3 \times$ RBW, Detector = Peak.
- Trace mode = max hold.
- Sweep = auto couple.
- Measure the maximum width of the emission that is constrained by the frequencies associated with the two amplitude points (upper and lower) that are attenuated by 6 dB relative to the maximum level measured in the fundamental emission

4.6.5 Deviation from Test Standard

No deviation.

4.6.6 EUT Operating Condition

The software provided by client to enable the EUT under transmission condition continuously at lowest, middle and highest channel frequencies individually.

4.6.7 Test Results

MODE A (1TX)
802.11a

Channel	Frequency (MHz)	6 dB Bandwidth (MHz)	Minimum Limit (MHz)	Pass / Fail
149	5745	16.36	0.5	Pass
157	5785	16.37	0.5	Pass
165	5825	16.38	0.5	Pass

MODE B (3TX)
802.11n (HT20)

Channel	Frequency (MHz)	6 dB Bandwidth (MHz)			Minimum Limit (MHz)	Pass / Fail
		Chain 0	Chain 1	Chain 2		
149	5745	17.56	16.29	15.83	0.5	Pass
157	5785	16.39	15.80	17.30	0.5	Pass
165	5825	16.89	16.42	16.97	0.5	Pass

802.11n (HT40)

Channel	Frequency (MHz)	6 dB Bandwidth (MHz)			Minimum Limit (MHz)	Pass / Fail
		Chain 0	Chain 1	Chain 2		
151	5755	35.75	35.16	35.15	0.5	Pass
159	5795	35.51	36.09	35.81	0.5	Pass

802.11ac (VHT80)

Channel	Frequency (MHz)	6 dB Bandwidth (MHz)			Minimum Limit (MHz)	Pass / Fail
		Chain 0	Chain 1	Chain 2		
155	5775	74.16	76.13	75.24	0.5	Pass

Spectrum Plot of Worst Value

802.11a

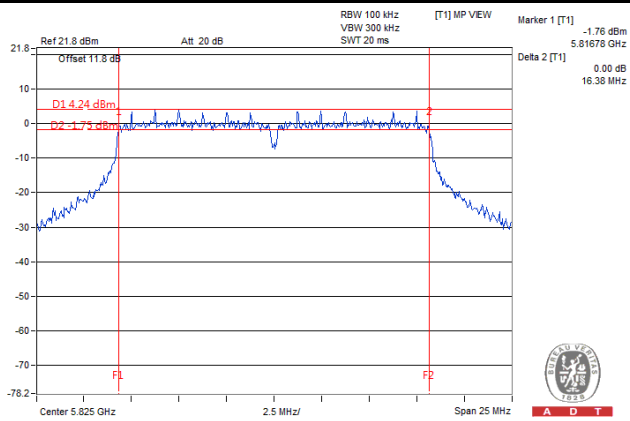

802.11n (HT20)

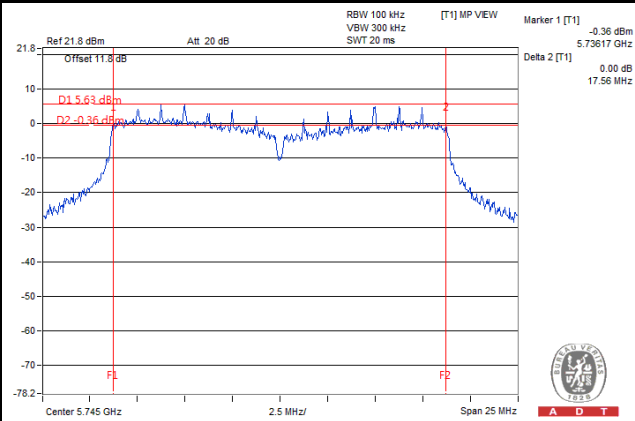

802.11n (HT40)

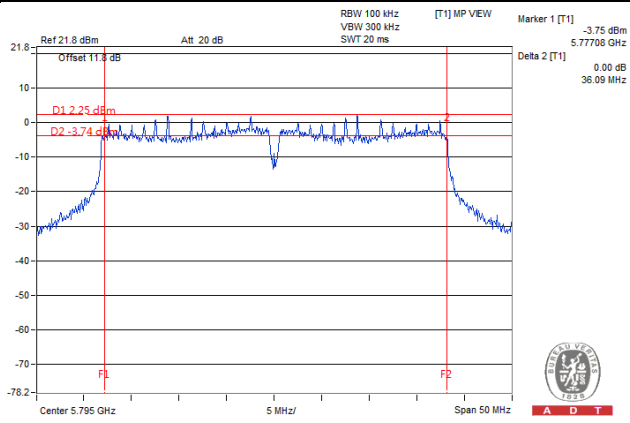

802.11ac (VHT80)

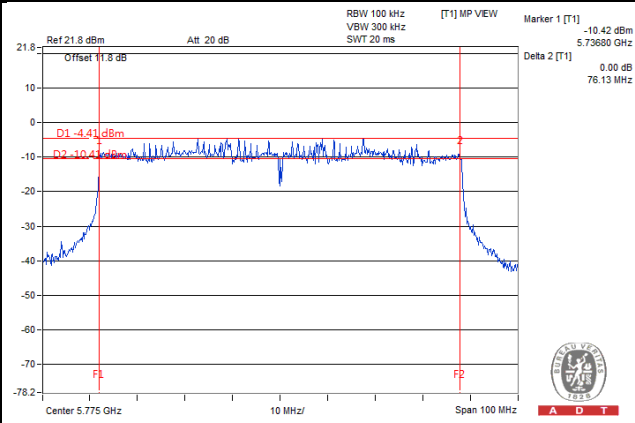

5 Pictures of Test Arrangements

Please refer to the attached file (Test Setup Photo).

Appendix – Information on the Testing Laboratories

We, Bureau Veritas Consumer Products Services (H.K.) Ltd., Taoyuan Branch, were founded in 1988 to provide our best service in EMC, Radio, Telecom and Safety consultation. Our laboratories are accredited and approved according to ISO/IEC 17025.

If you have any comments, please feel free to contact us at the following:

Linko EMC/RF Lab

Tel: 886-2-26052180

Fax: 886-2-26051924

Hsin Chu EMC/RF/Telecom Lab

Tel: 886-3-6668565

Fax: 886-3-6668323

Hwa Ya EMC/RF/Safety

Tel: 886-3-3183232

Fax: 886-3-3270892

Email: service.adt@tw.bureauveritas.com

Web Site: www.bureauveritas-adt.com

The address and road map of all our labs can be found in our web site also.

--- END ---