

Figure 6-152 Spurious Emissions 2115.0MHz TX1\_16QAM 10MHz Band Edge (ACP 15kHz – 550KHz)

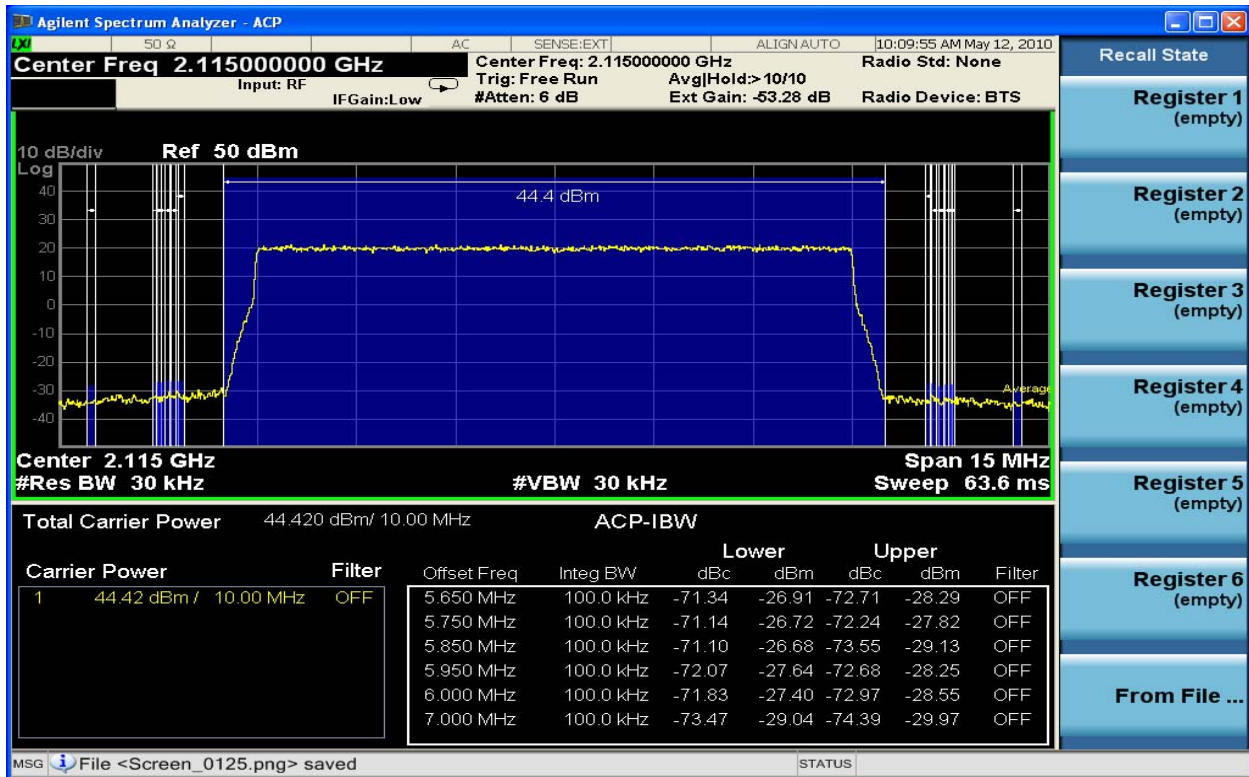

Figure 6-153 Spurious Emissions 2115.0MHz TX1\_16QAM 10MHz Band Edge (ACP 650kHz – 2MHz)

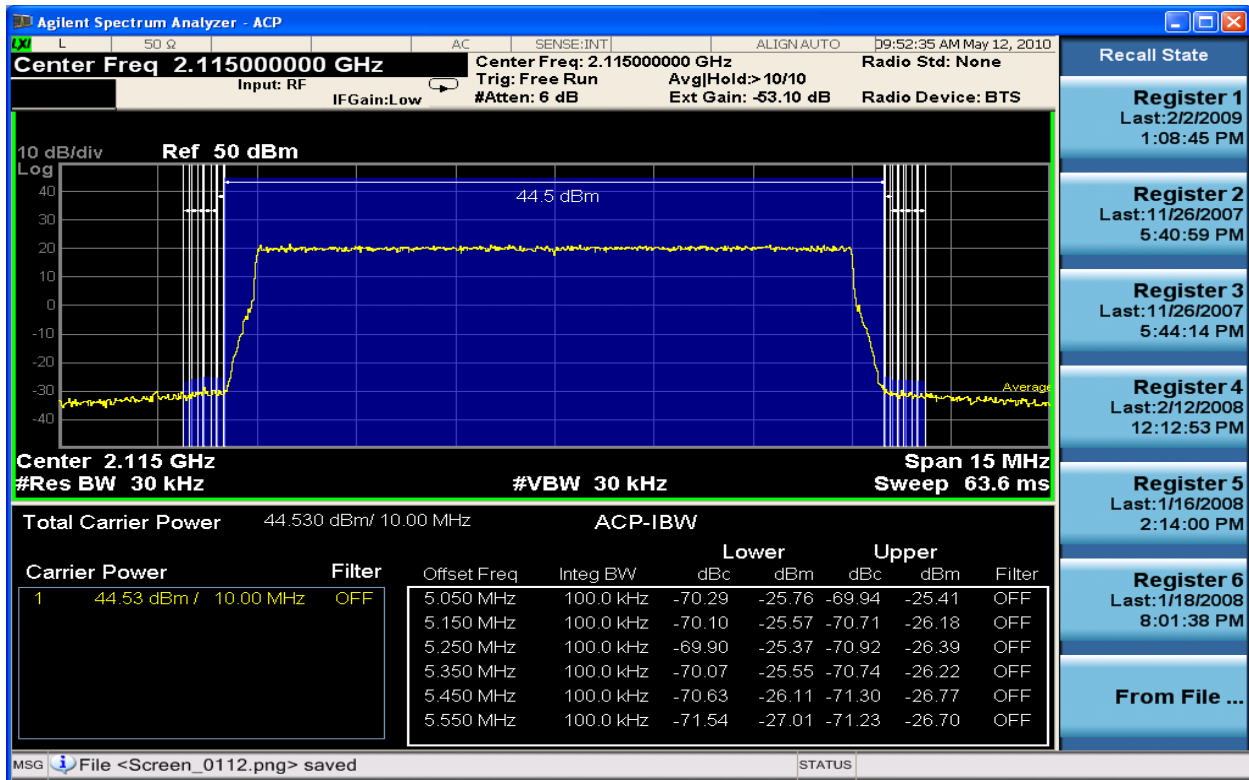

Figure 6-154 Spurious Emissions 2115.0MHz TX2\_16QAM 10MHz Band Edge (ACP 15kHz – 550KHz)

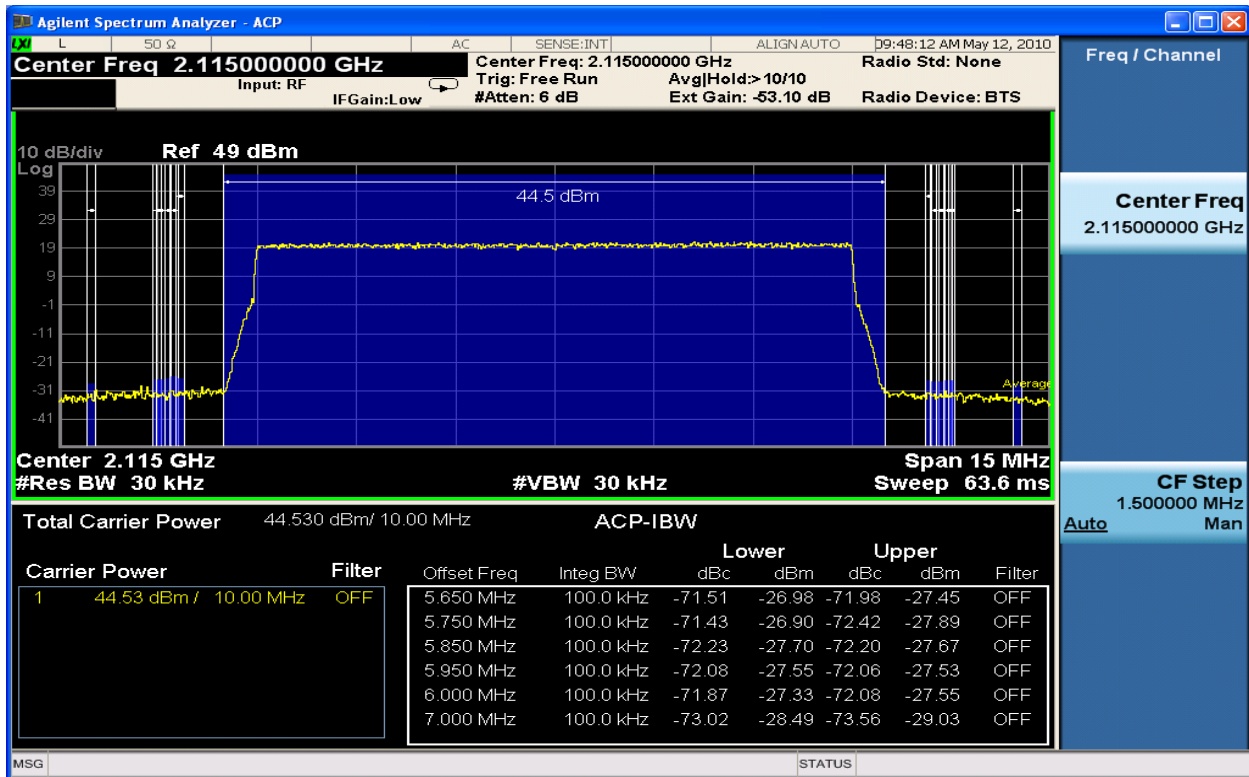

Figure 6-155 Spurious Emissions 2115.0MHz TX2\_16QAM 10MHz Band Edge (ACP 650kHz – 2MHz)

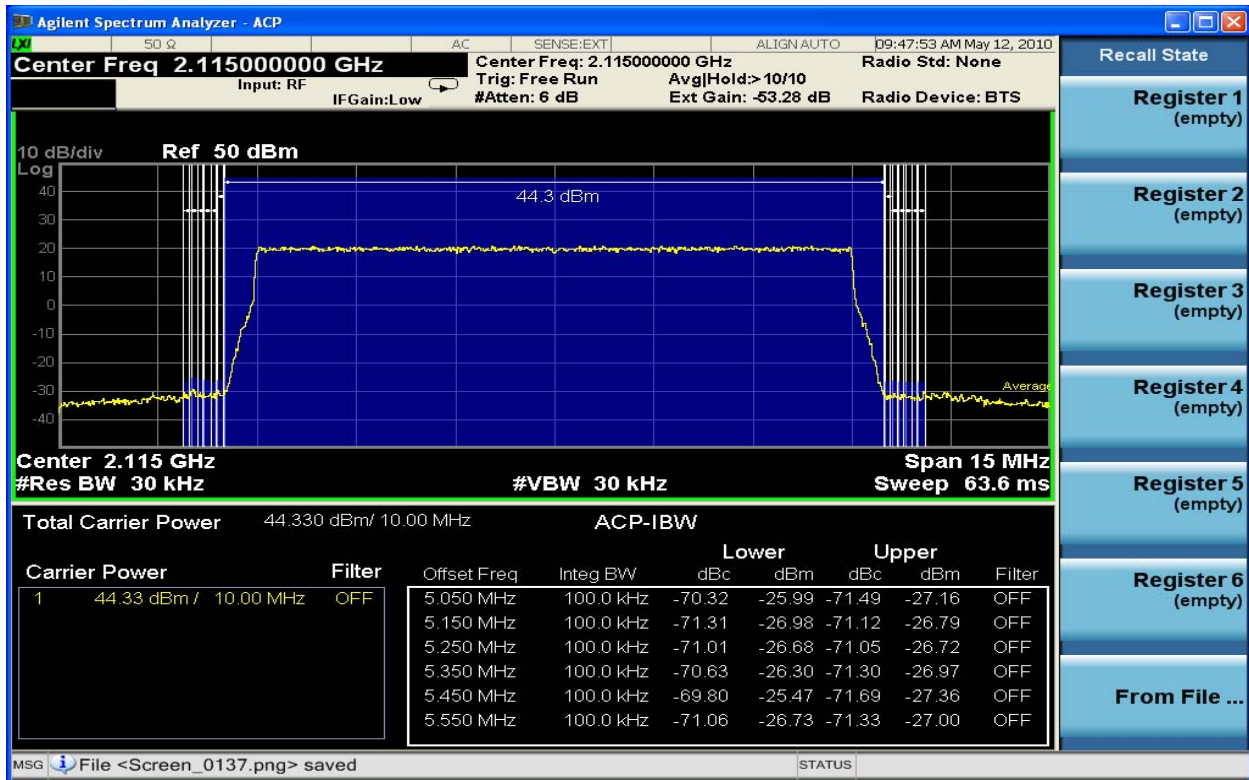

Figure 6-156 Spurious Emissions 2115.0MHz TX1\_64QAM 10MHz Band Edge (ACP 15kHz – 550KHz)

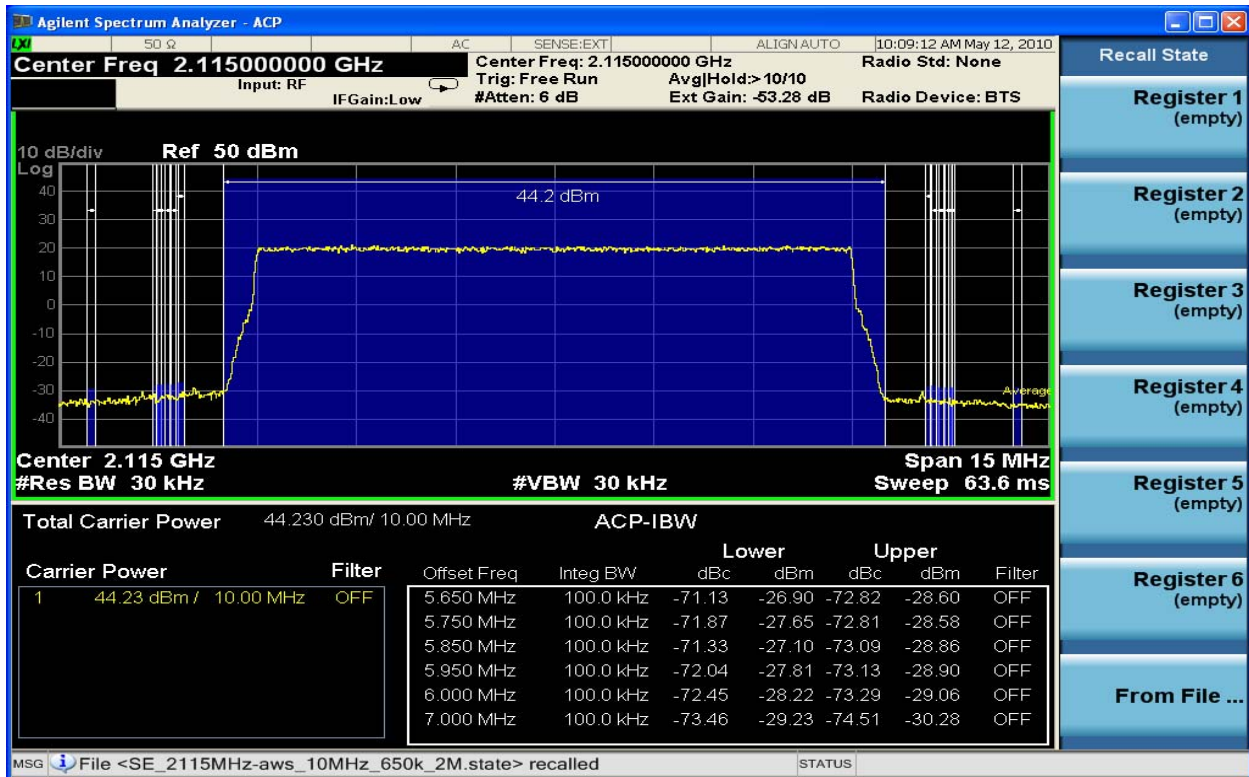

Figure 6-157 Spurious Emissions 2115.0MHz TX1\_64QAM 10MHz Band Edge (ACP 650kHz – 2MHz)

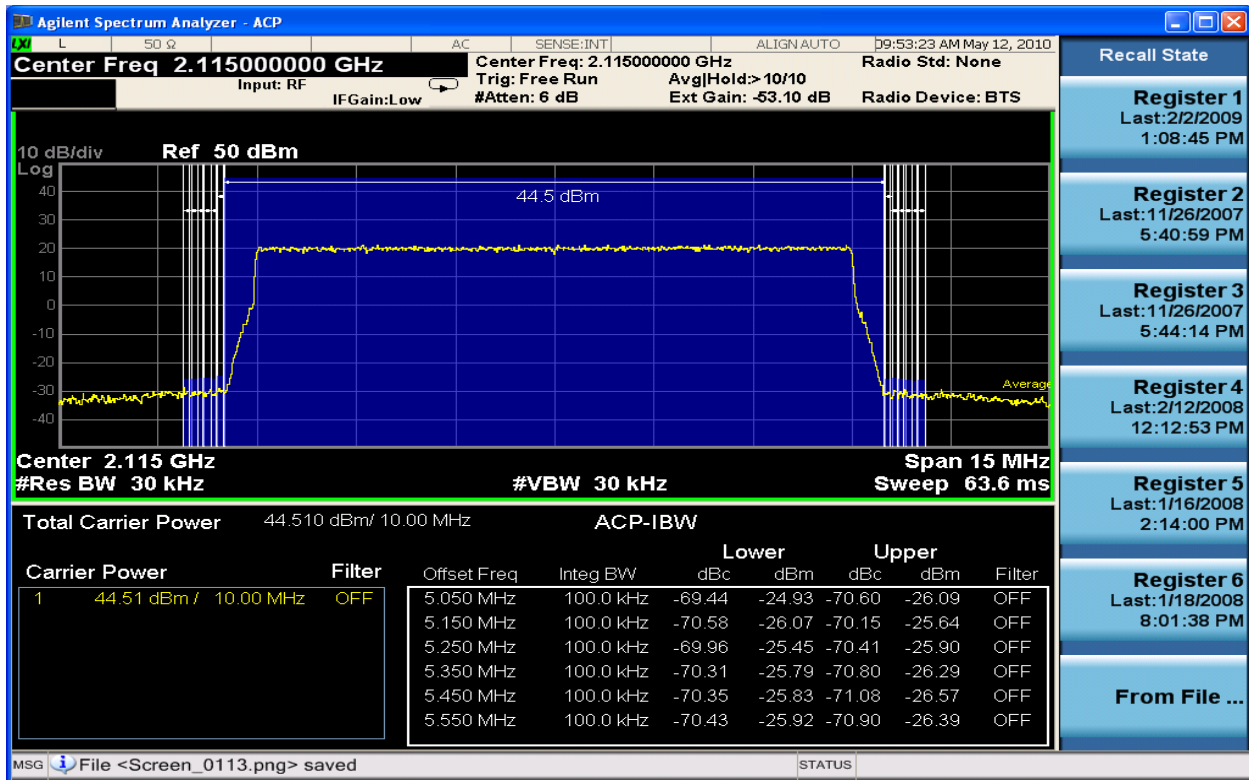

Figure 6-158 Spurious Emissions 2115.0MHz TX2\_64QAM 10MHz Band Edge (ACP 15kHz – 550KHz)

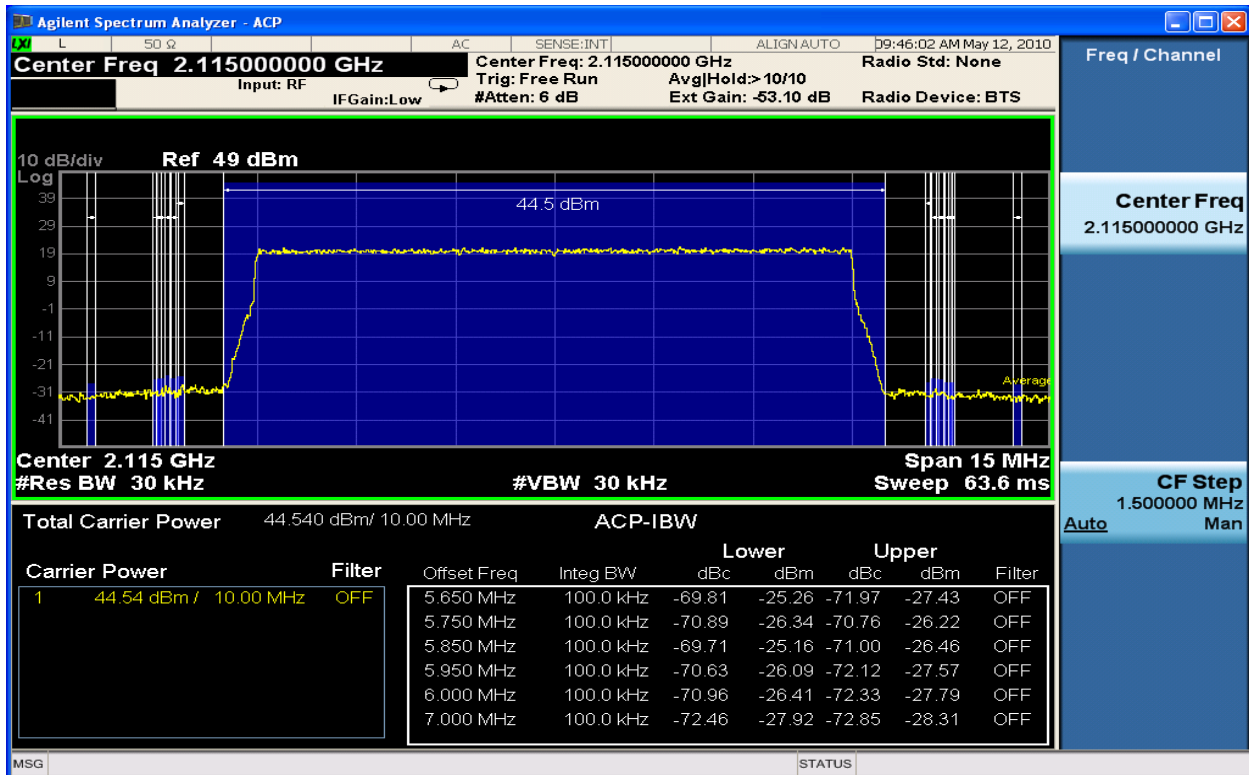

Figure 6-159 Spurious Emissions 2115.0MHz TX2\_64QAM 10MHz Band Edge (ACP 650kHz – 2MHz)



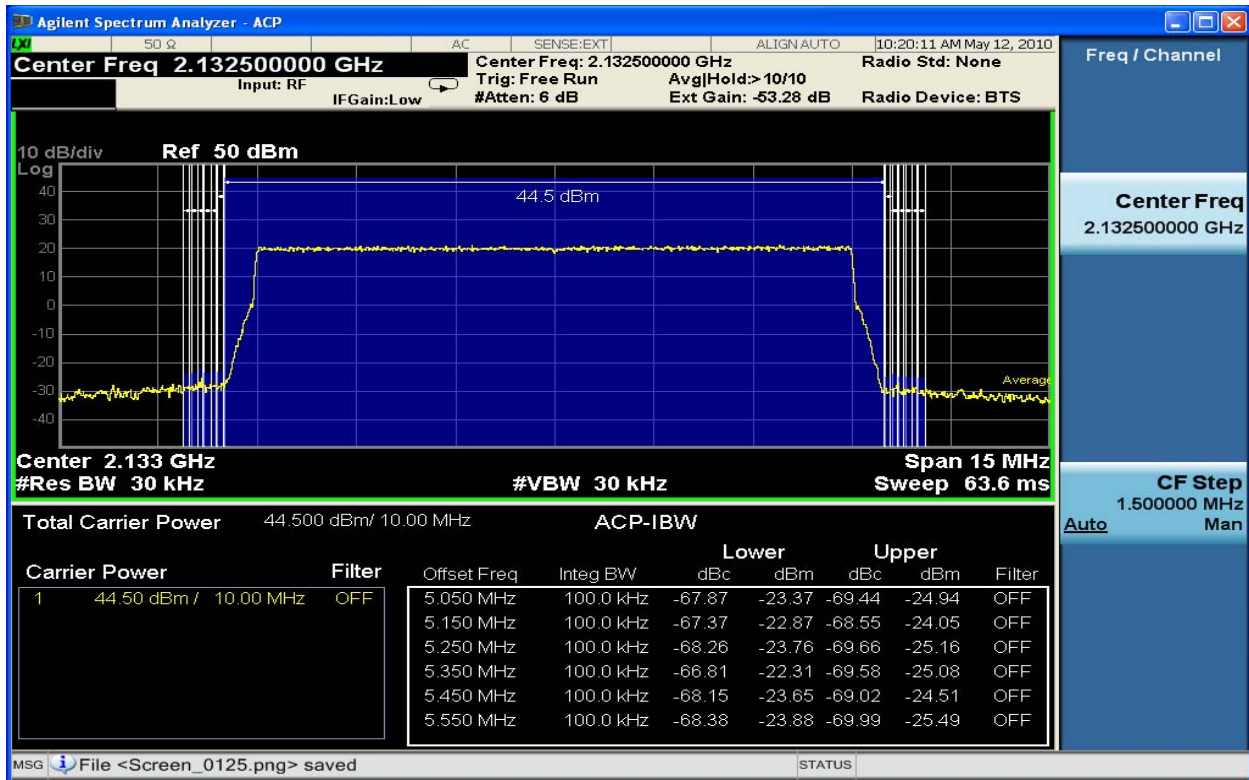

Figure 6-160 Spurious Emissions 2132.5MHz TX1\_QPSK 10MHz Band Edge (ACP 15kHz – 550KHz)

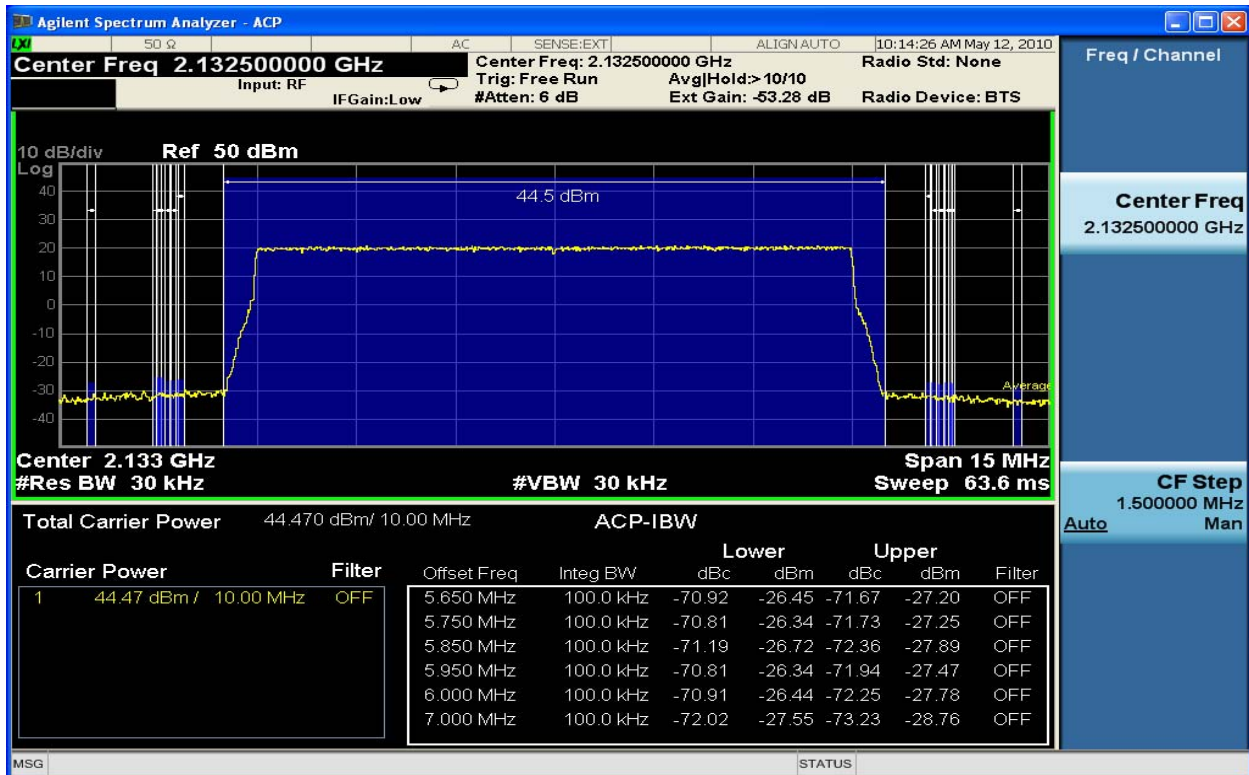

Figure 6-161 Spurious Emissions 2132.5MHz TX1\_QPSK 10MHz Band Edge (ACP 650kHz – 2MHz)

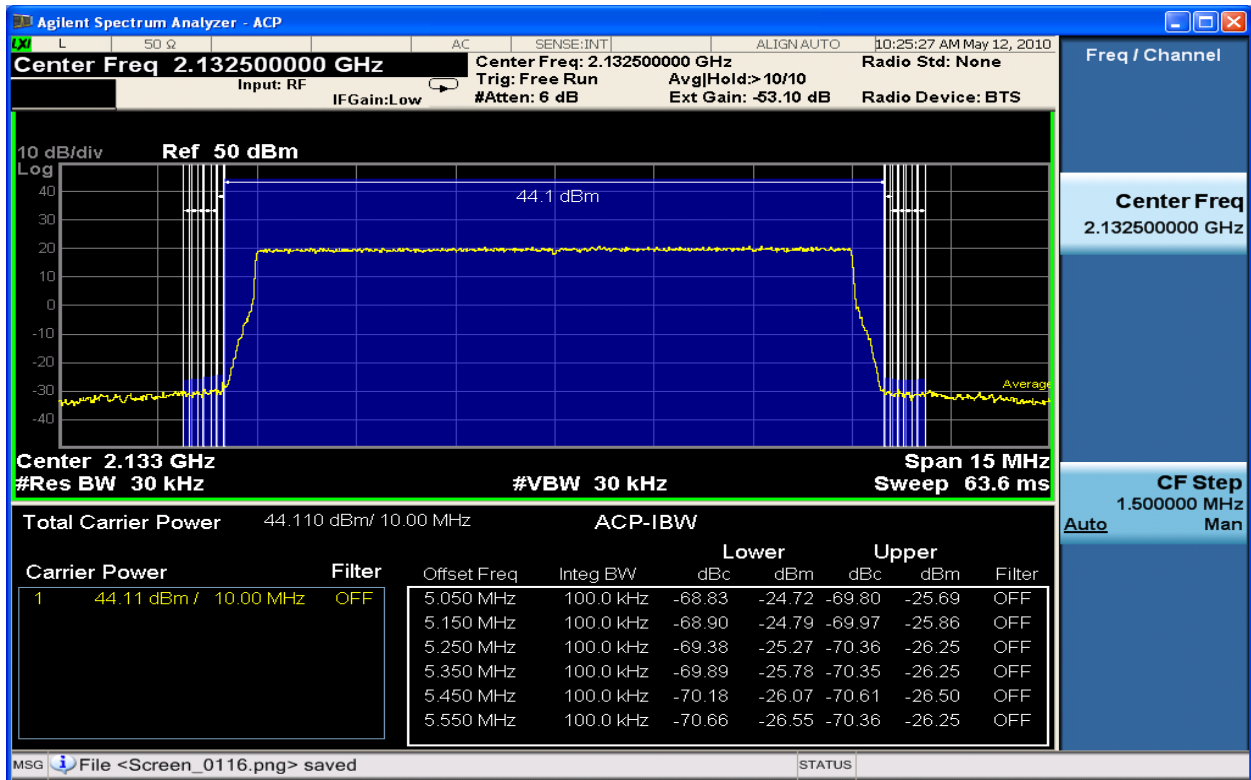

Figure 6-162 Spurious Emissions 2132.5MHz TX2\_QPSK 10MHz Band Edge (ACP 15kHz – 550KHz)

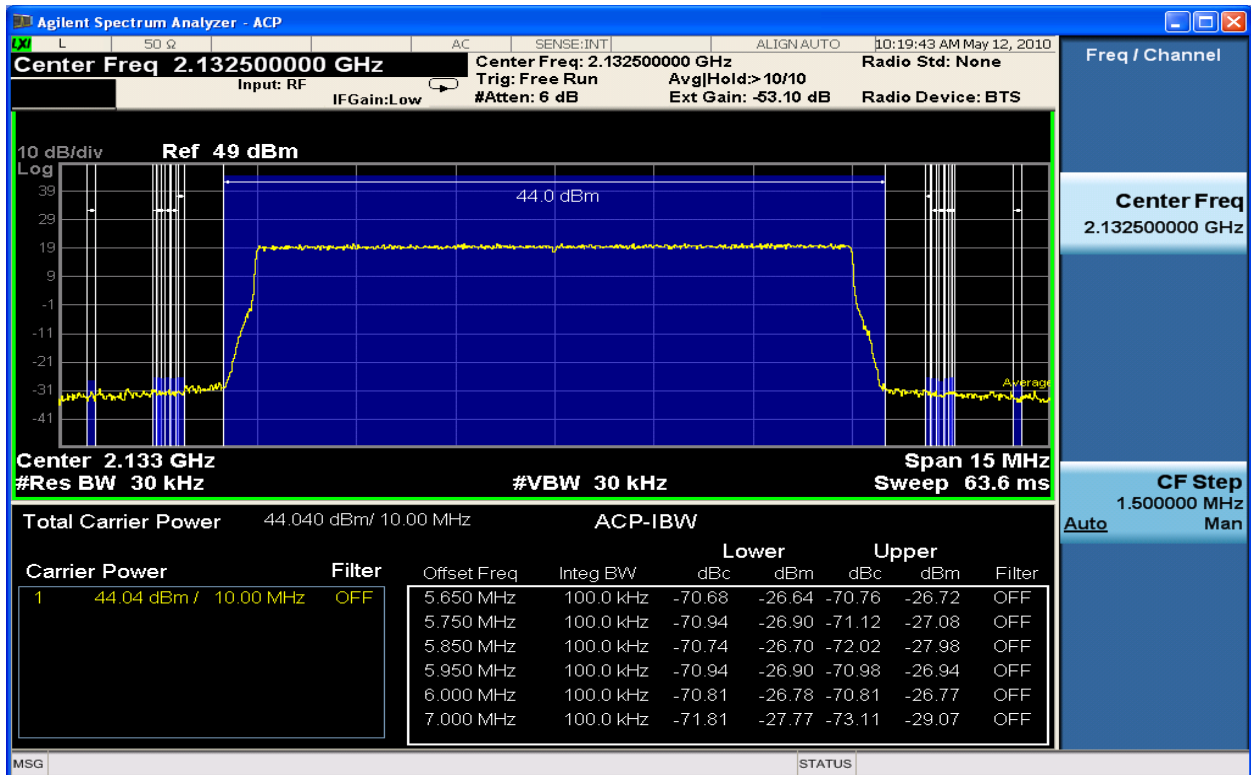

Figure 6-163 Spurious Emissions 2132.5MHz TX2\_QPSK 10MHz Band Edge (ACP 650kHz – 2MHz)

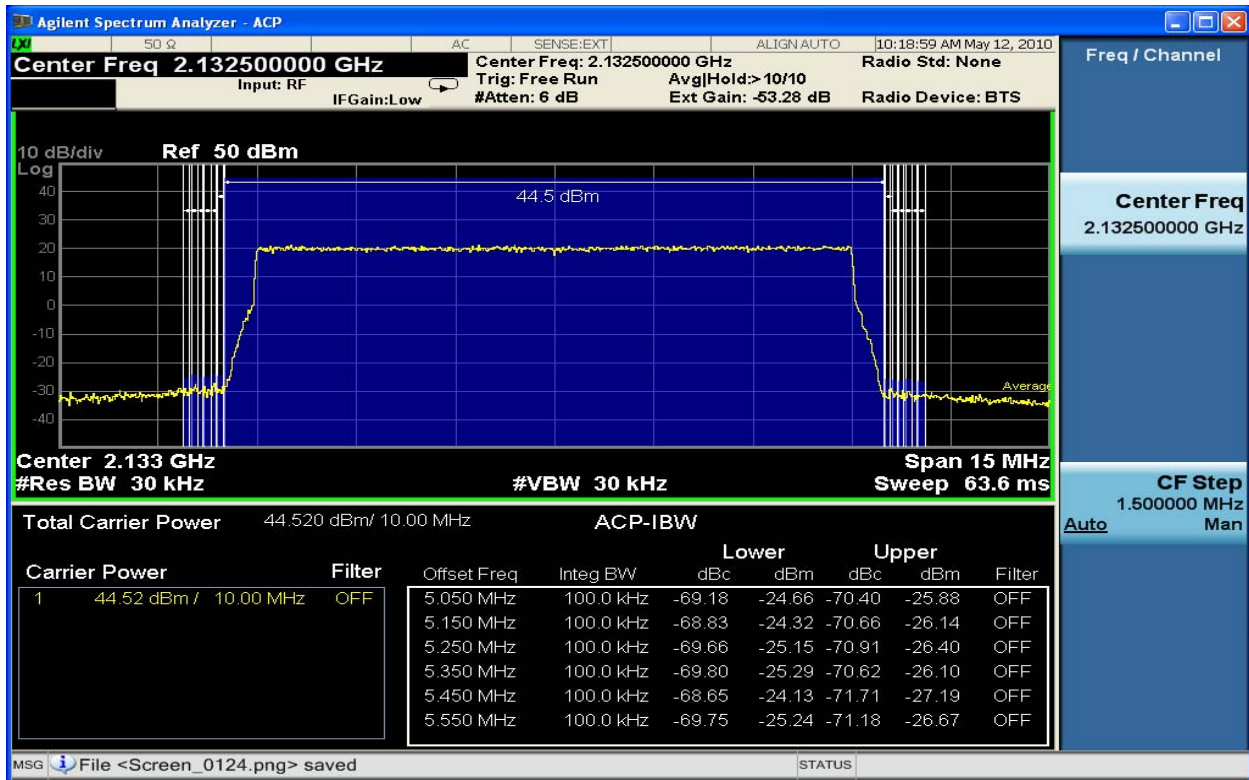

Figure 6-164 Spurious Emissions 2132.5MHz TX1\_16QAM 10MHz Band Edge (ACP 15kHz – 550kHz)

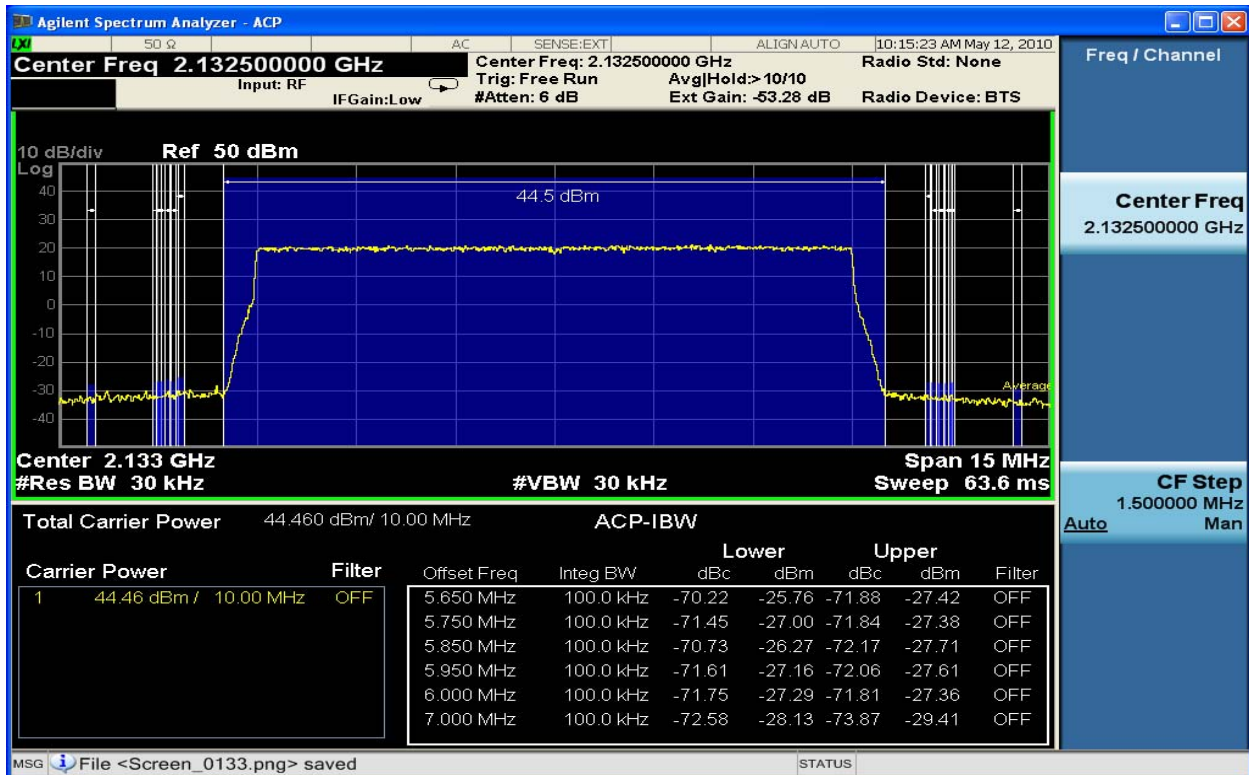

Figure 6-165 Spurious Emissions 2132.5MHz TX1\_16QAM 10MHz Band Edge (ACP 650kHz – 2MHz)

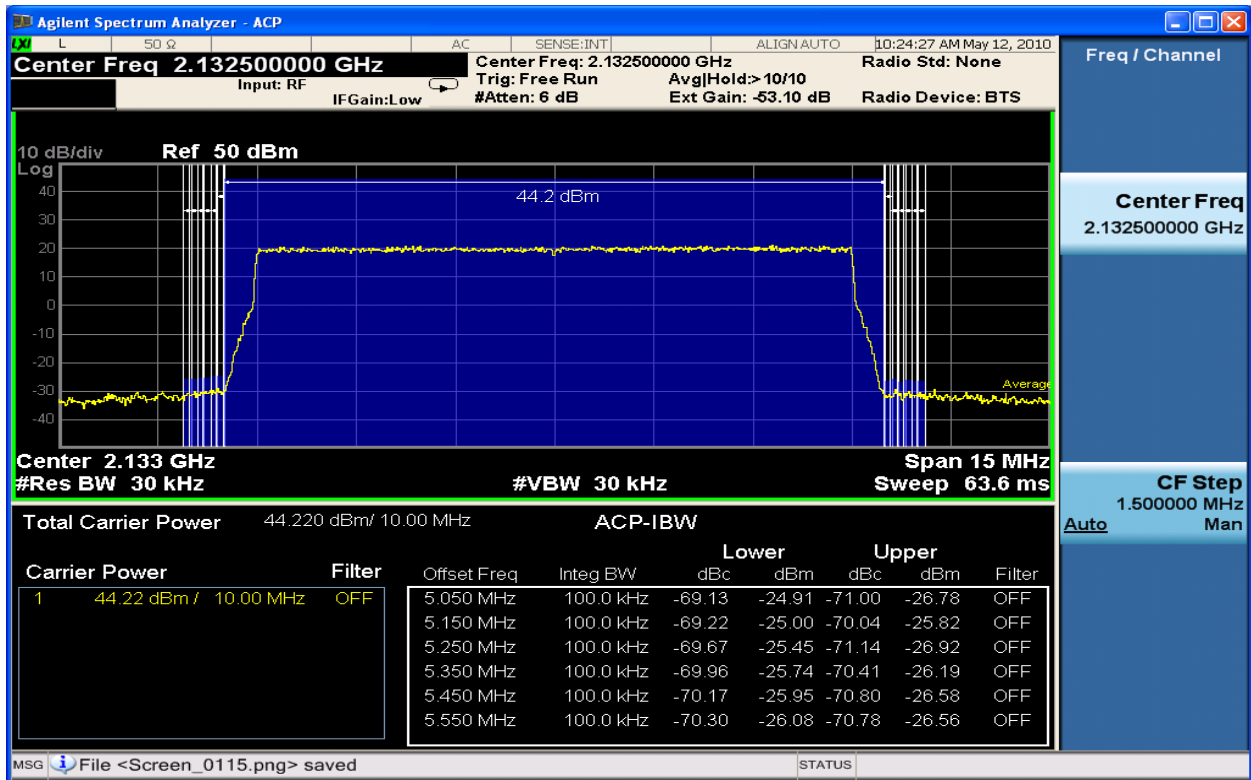

Figure 6-166 Spurious Emissions 2132.5MHz TX2\_16QAM 10MHz Band Edge (ACP 15kHz – 550kHz)

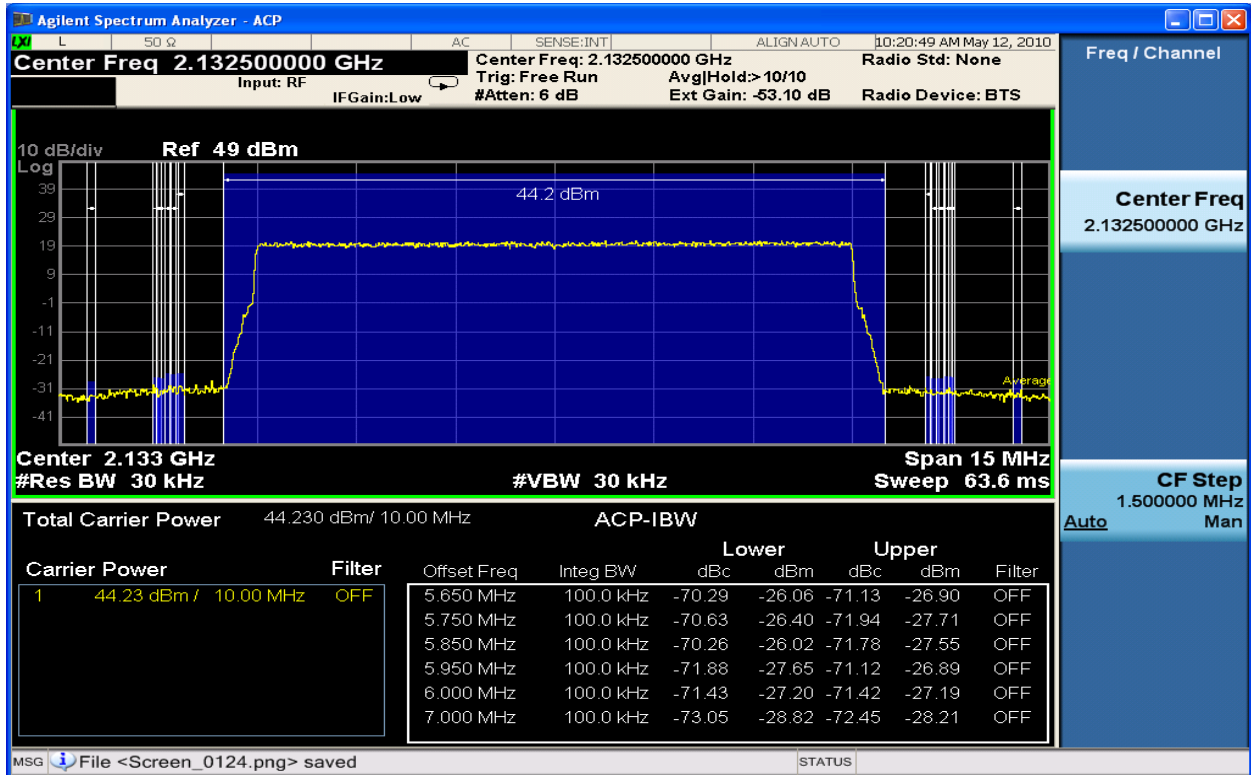

Figure 6-167 Spurious Emissions 2132.5MHz TX2\_16QAM 10MHz Band Edge (ACP 650kHz – 2MHz)



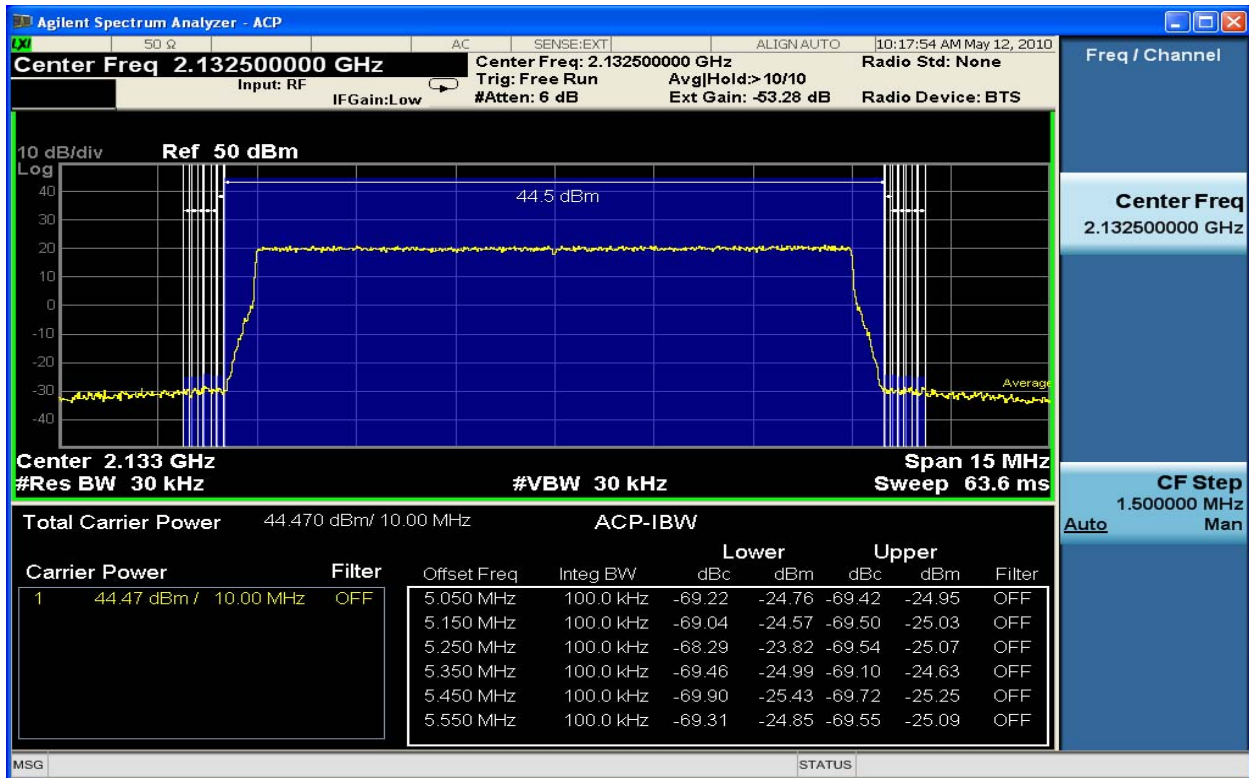

Figure 6-168 Spurious Emissions 2132.5MHz TX1\_64QAM 10MHz Band Edge (ACP 15kHz – 550kHz)

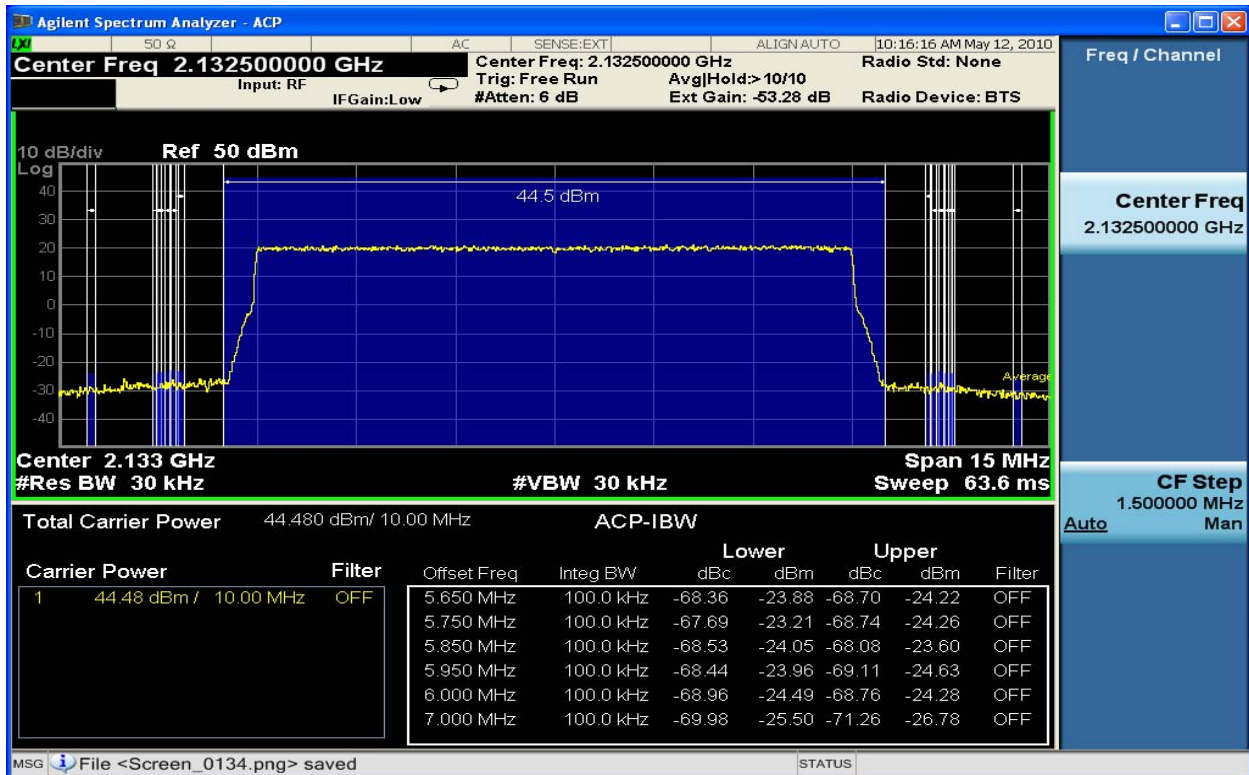

Figure 6-169 Spurious Emissions 2132.5MHz TX1\_64QAM 10MHz Band Edge (ACP 650kHz – 2MHz)

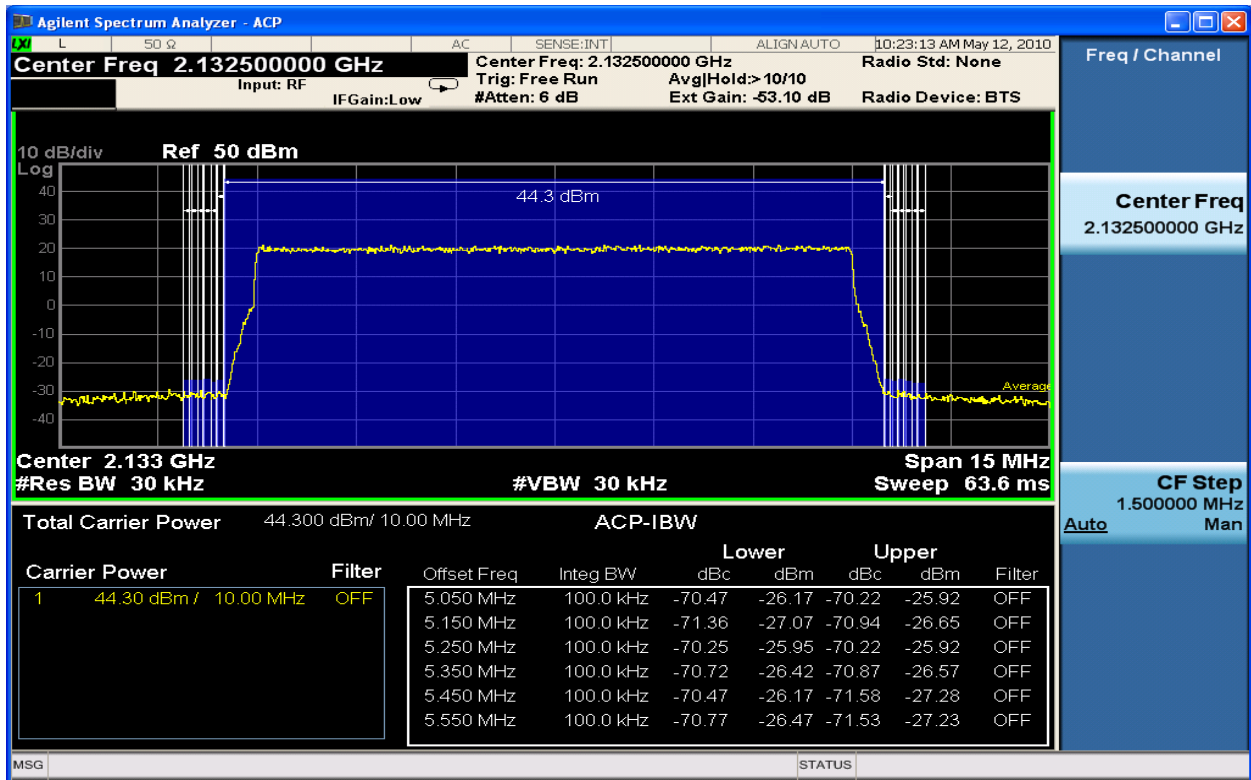

Figure 6-170 Spurious Emissions 2132.5MHz TX2\_64QAM 10MHz Band Edge (ACP 15kHz – 550kHz)

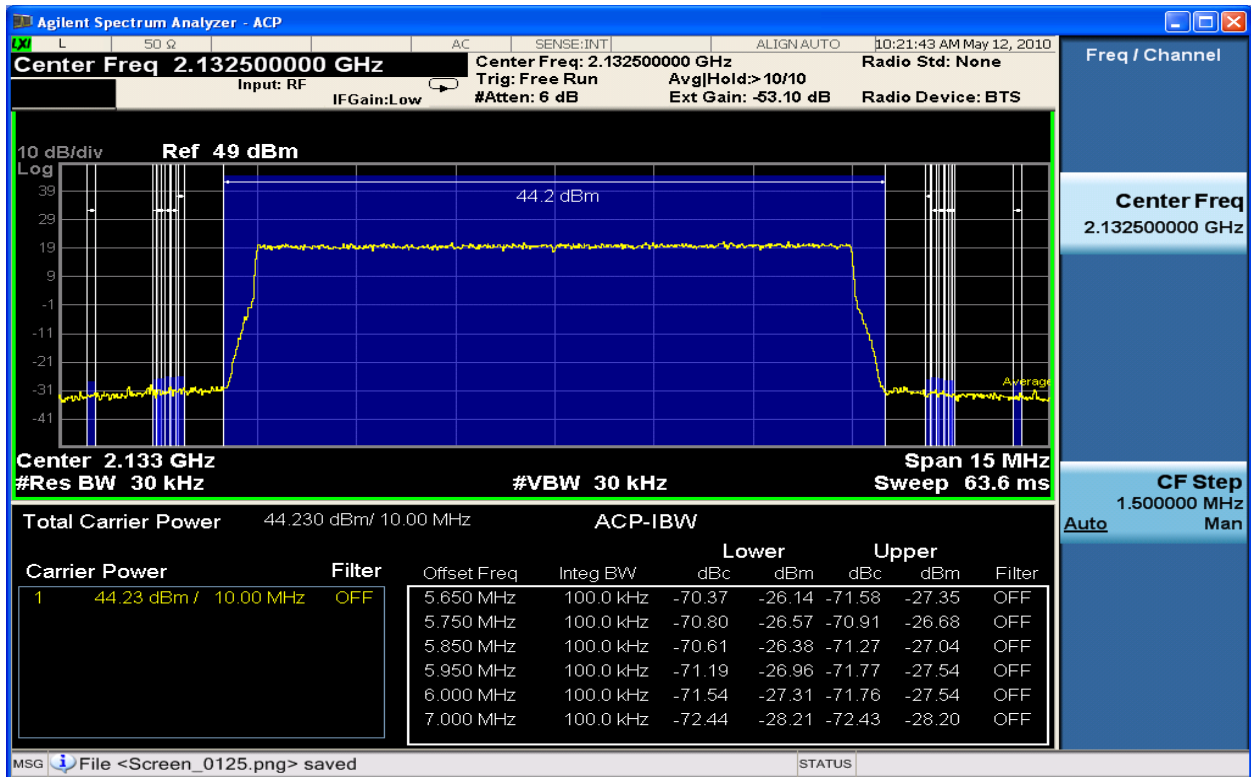

Figure 6-171 Spurious Emissions 2132.5MHz TX2\_64QAM 10MHz Band Edge (ACP 650kHz – 2MHz)

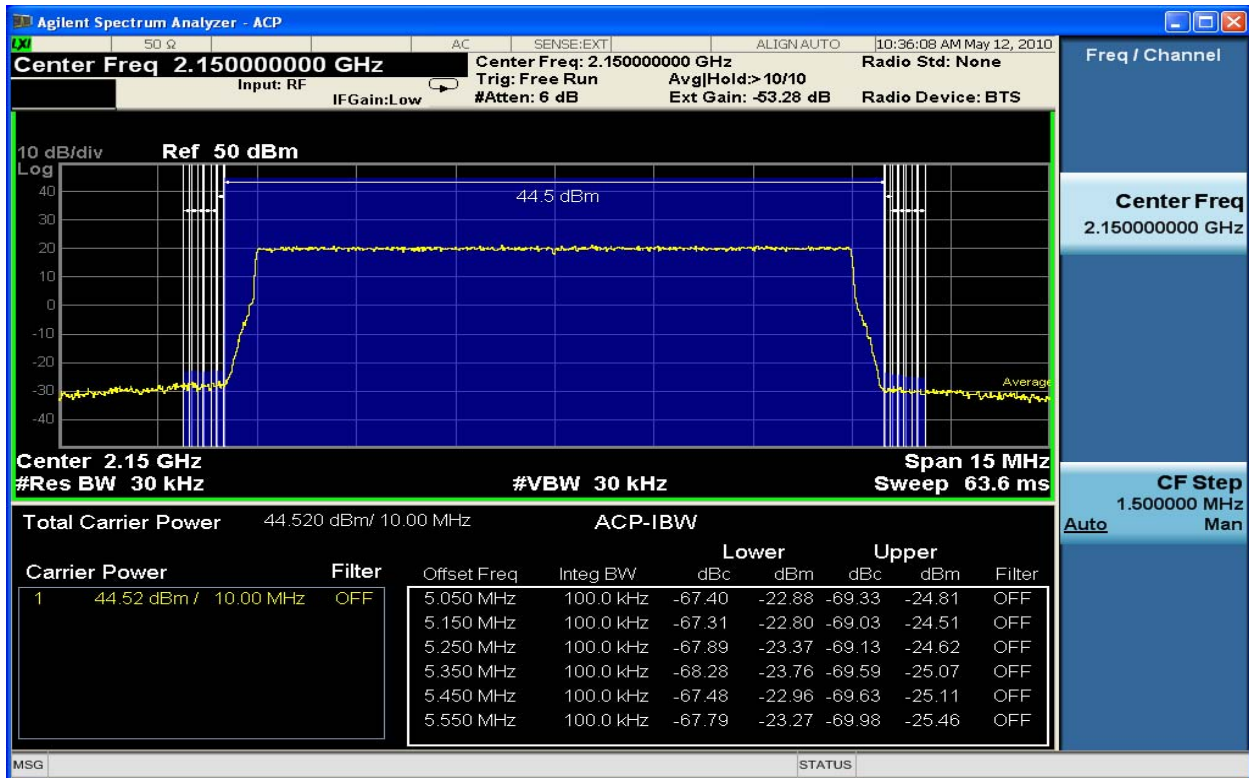

Figure 6-172 Spurious Emissions 2150.0MHz TX1\_QPSK 10MHz Band Edge (ACP 15kHz – 550KHz)

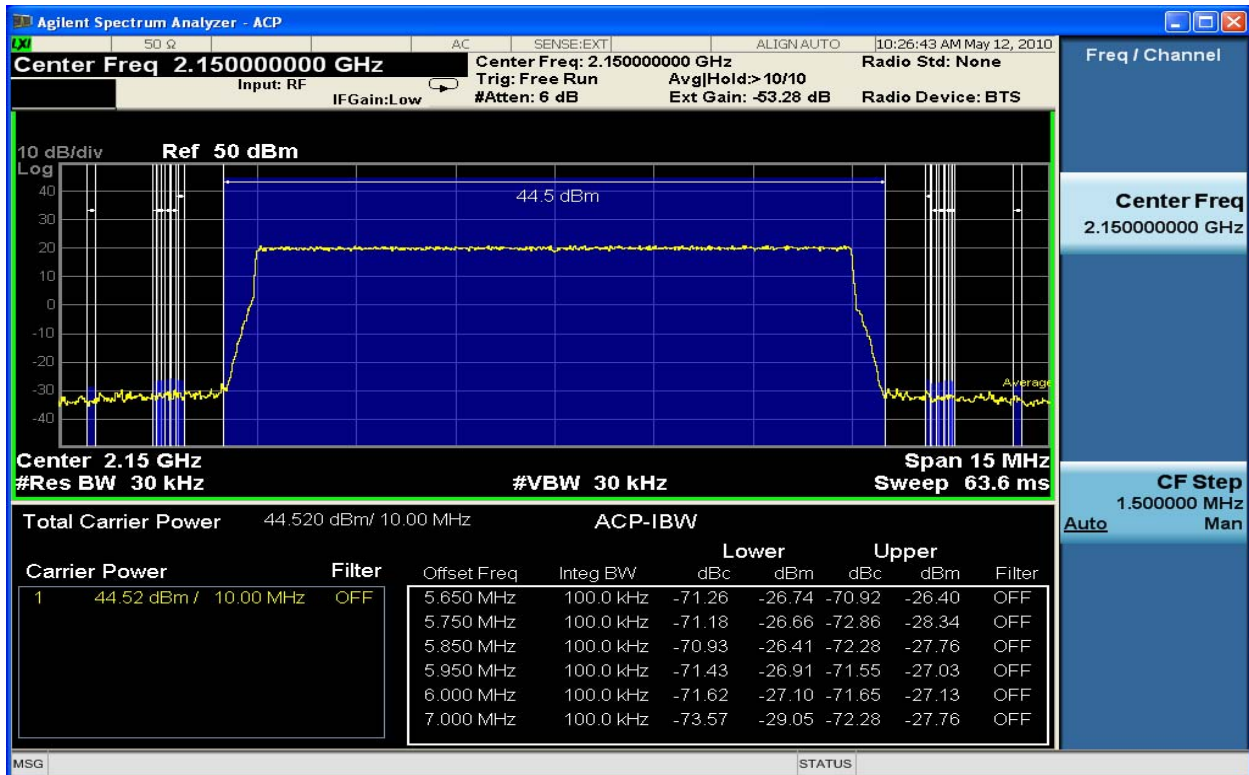

Figure 6-173 Spurious Emissions 2150.0MHz TX1\_QPSK 10MHz Band Edge (ACP 650kHz – 2MHz)

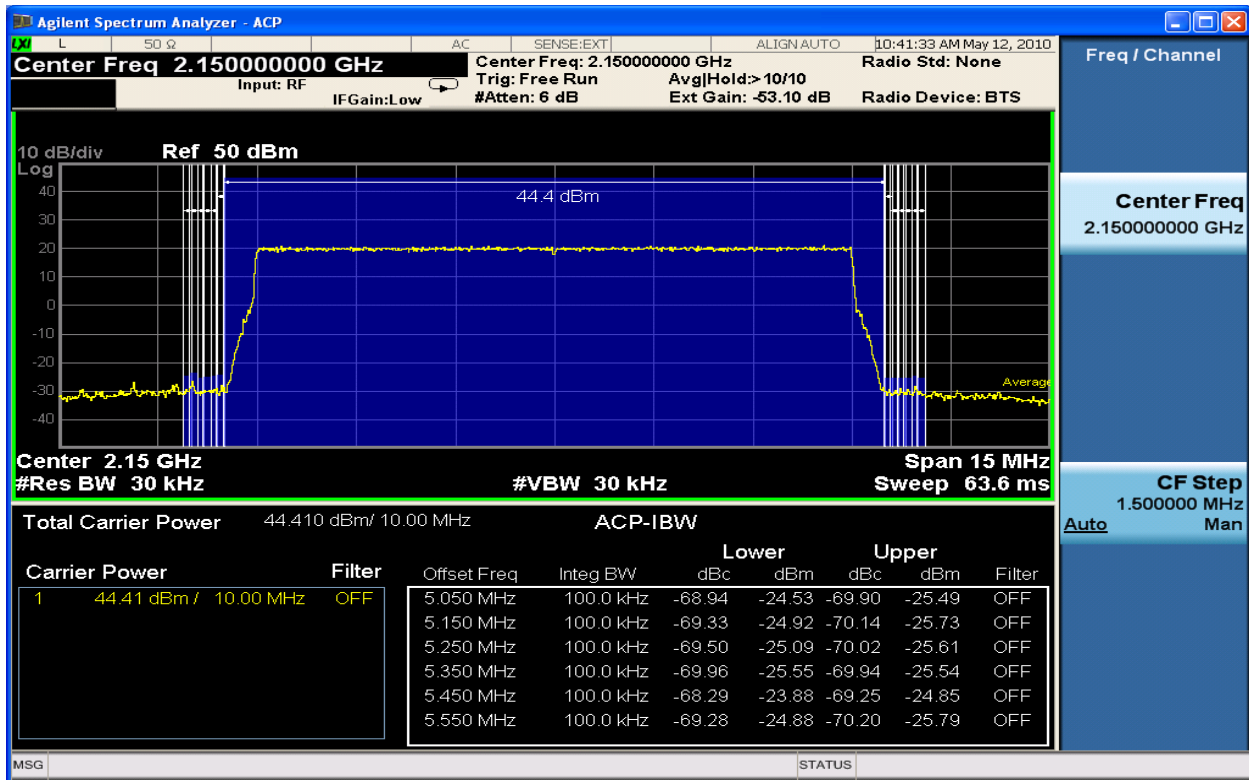

Figure 6-174 Spurious Emissions 2150.0MHz TX2\_QPSK 10MHz Band Edge (ACP 15kHz – 550KHz)

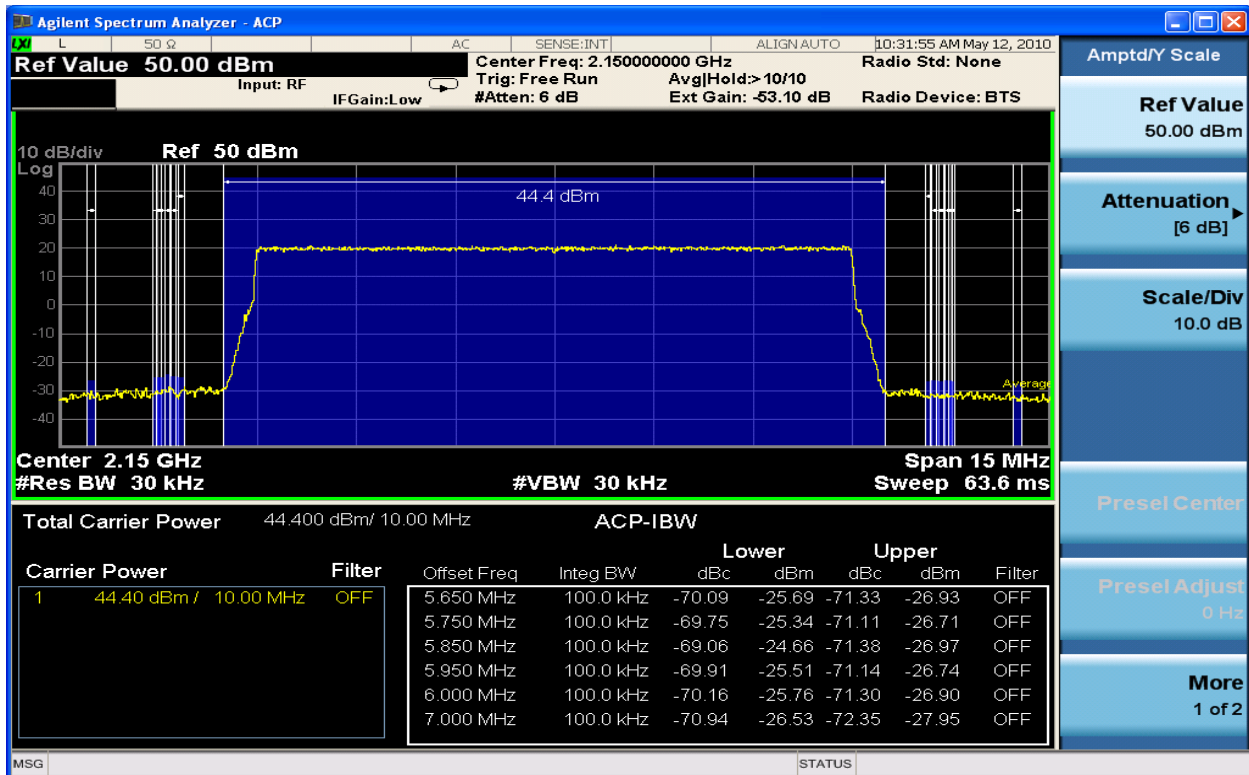

Figure 6-175 Spurious Emissions 2150.0MHz TX2\_QPSK 10MHz Band Edge (ACP 650kHz – 2MHz)



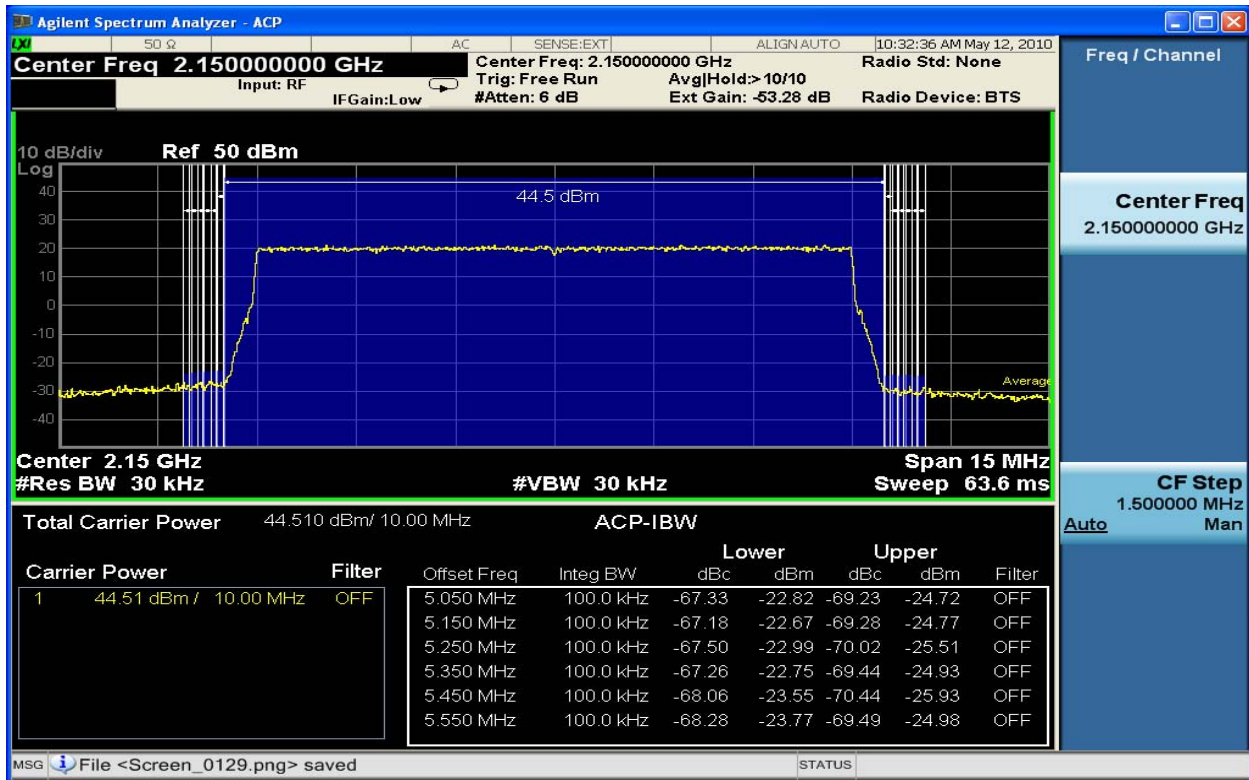

Figure 6-176 Spurious Emissions 2150.0MHz TX1\_16QAM 10MHz Band Edge (ACP 15kHz – 550kHz)

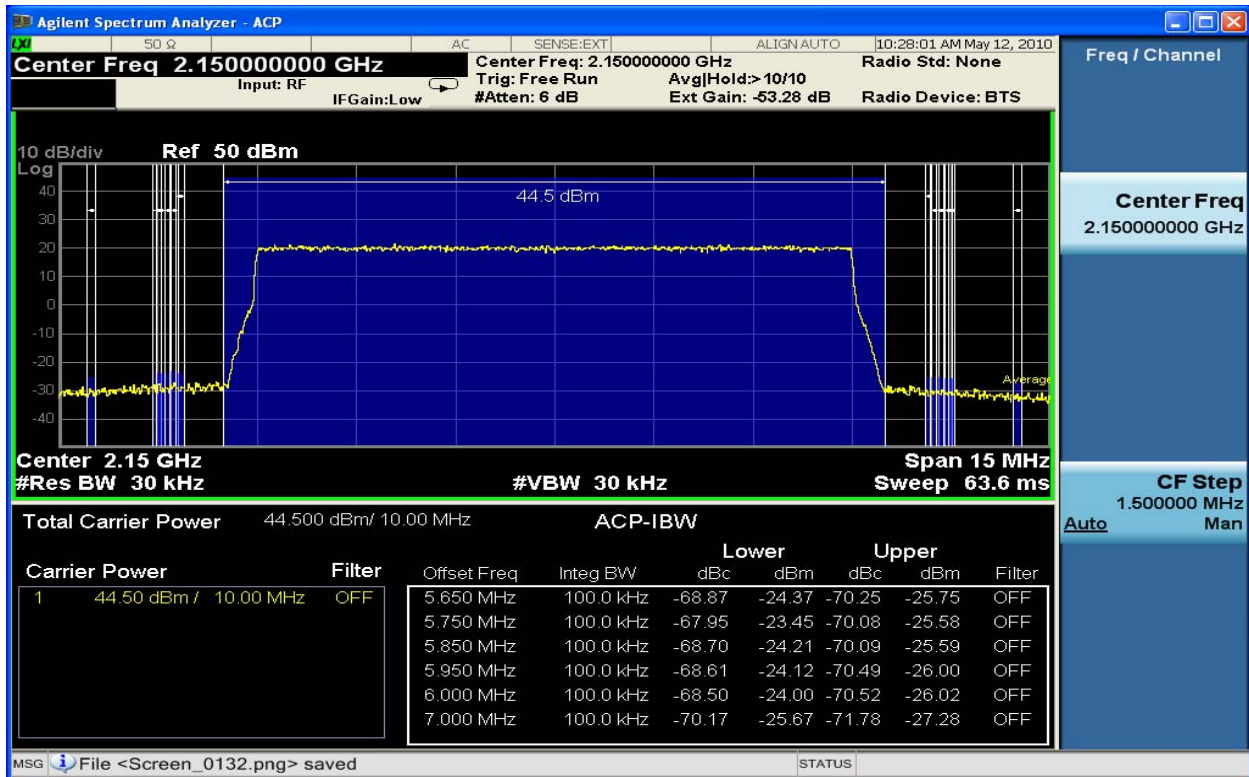

Figure 6-177 Spurious Emissions 2150.0MHz TX1\_16QAM 10MHz Band Edge (ACP 650kHz – 2MHz)

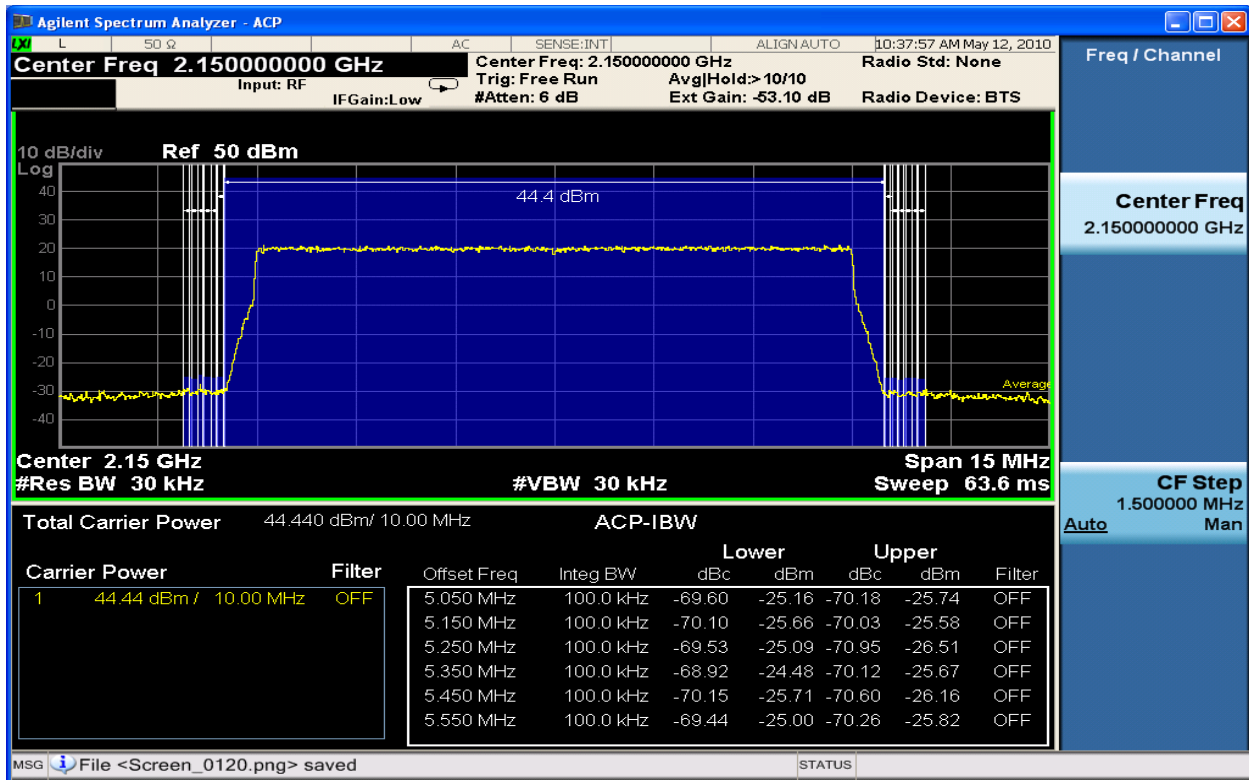

Figure 6-178 Spurious Emissions 2150.0MHz TX2\_16QAM 10MHz Band Edge (ACP 15kHz – 550kHz)

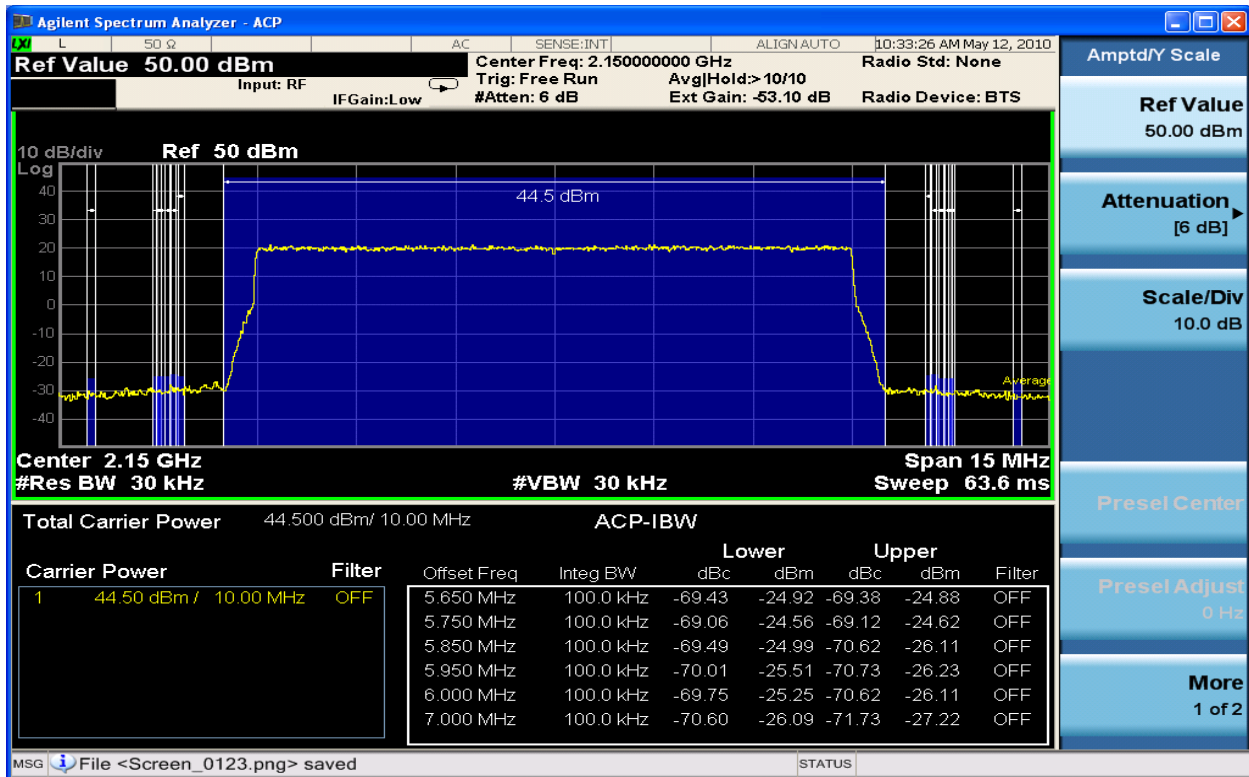

Figure 6-179 Spurious Emissions 2150.0MHz TX2\_16QAM 10MHz Band Edge (ACP 650kHz – 2MHz)

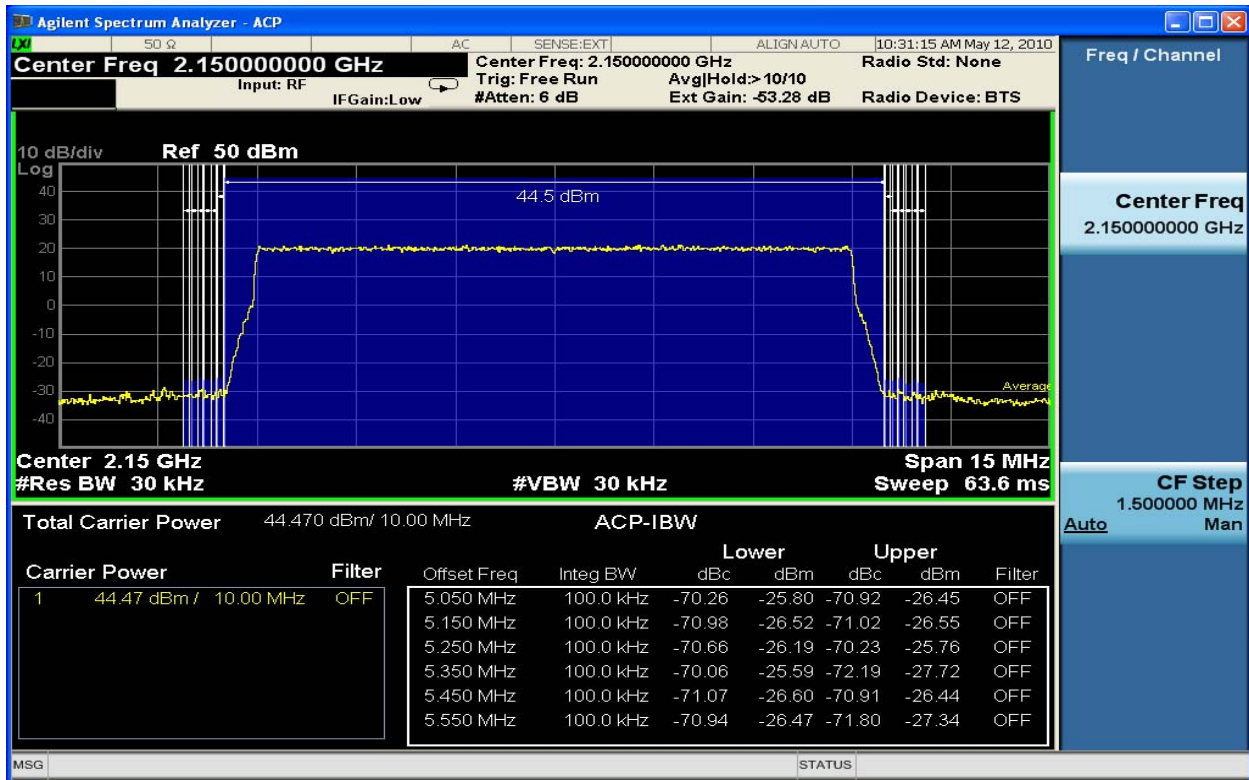

Figure 6-180 Spurious Emissions 2150.0MHz TX1\_64QAM 10MHz Band Edge (ACP 15kHz – 550kHz)

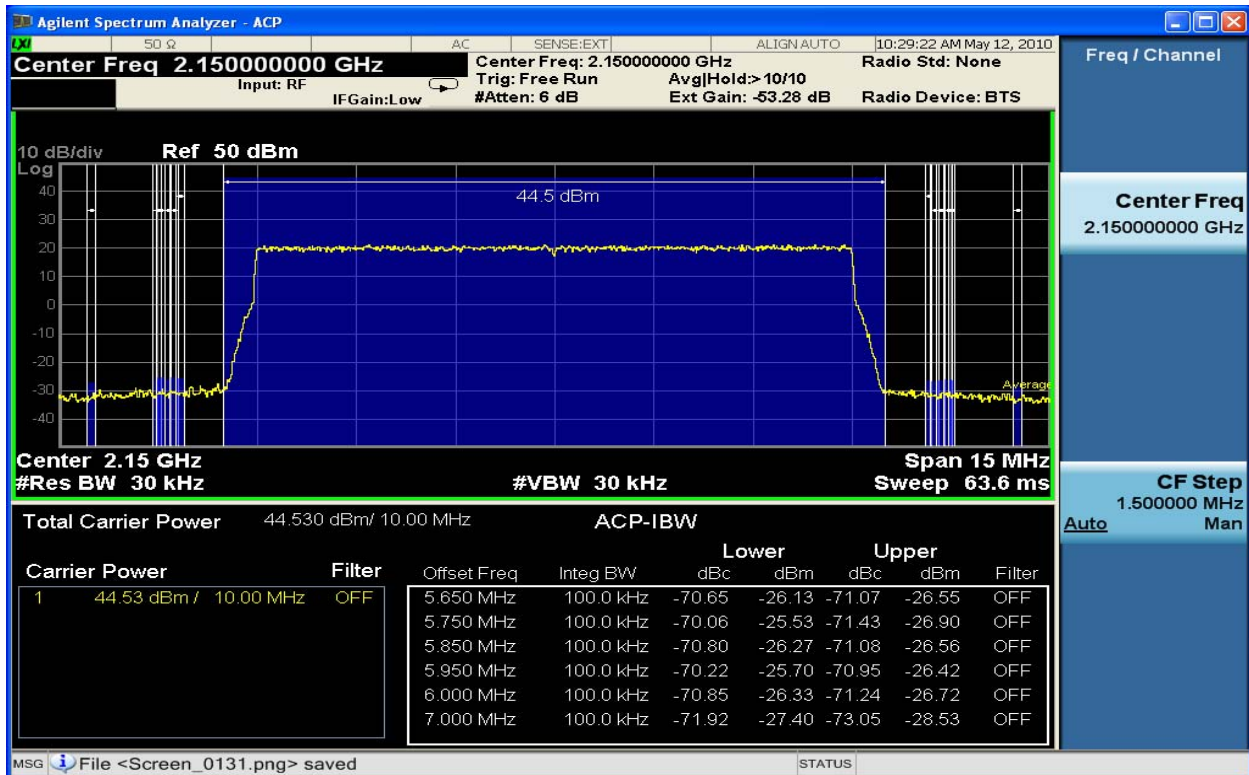

Figure 6-181 Spurious Emissions 2150.0MHz TX1\_64QAM 10MHz Band Edge (ACP 650kHz – 2MHz)

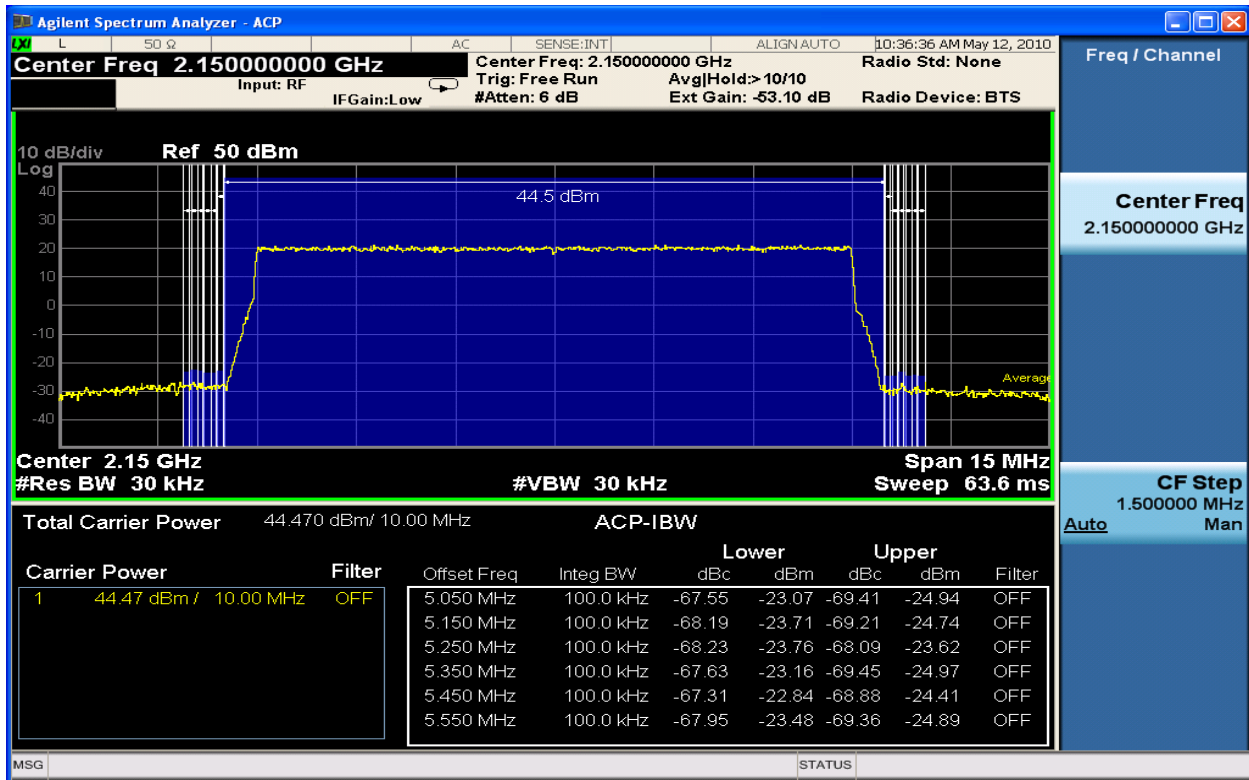

Figure 6-182 Spurious Emissions 2150.0MHz TX2\_64QAM 10MHz Band Edge (ACP 15kHz – 550kHz)

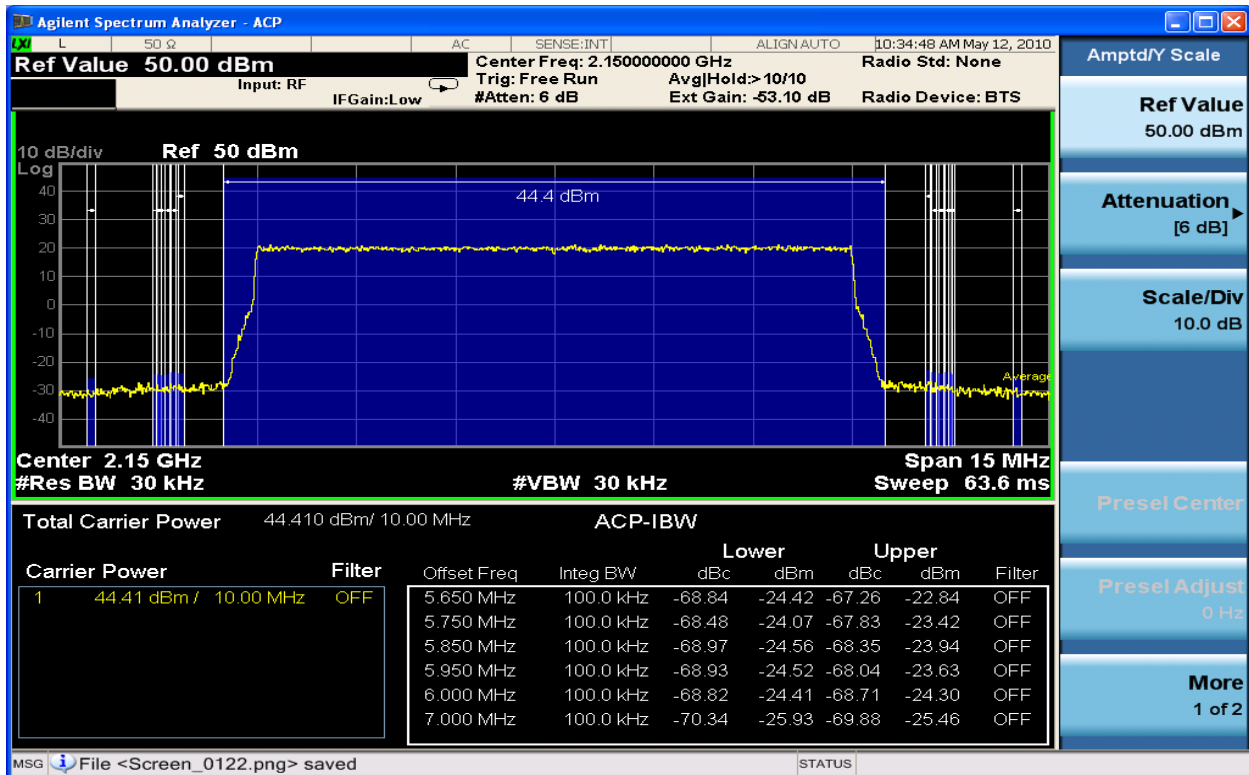

Figure 6-183 Spurious Emissions 2150.0MHz TX2\_64QAM 10MHz Band Edge (ACP 650kHz – 2MHz)



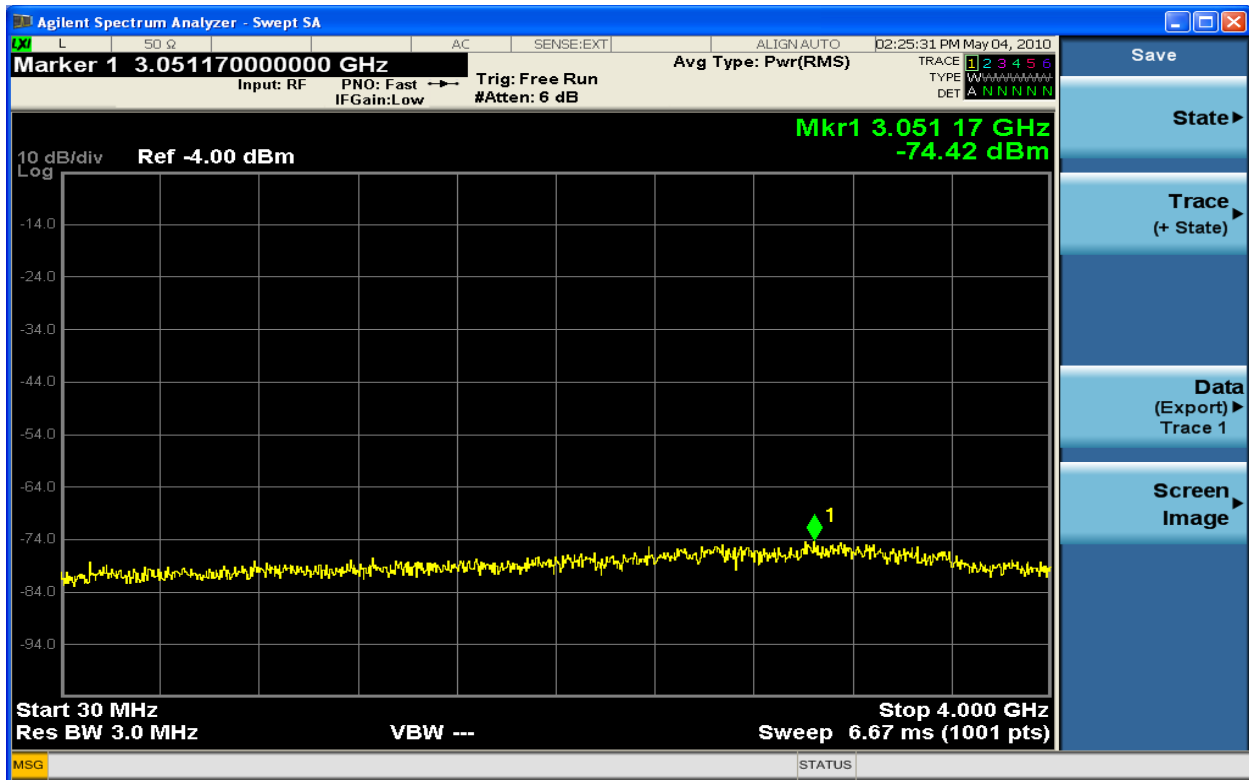

Figure 6-184 MXA (TX1) Noise Floor Reference (30MHz - 4GHz)

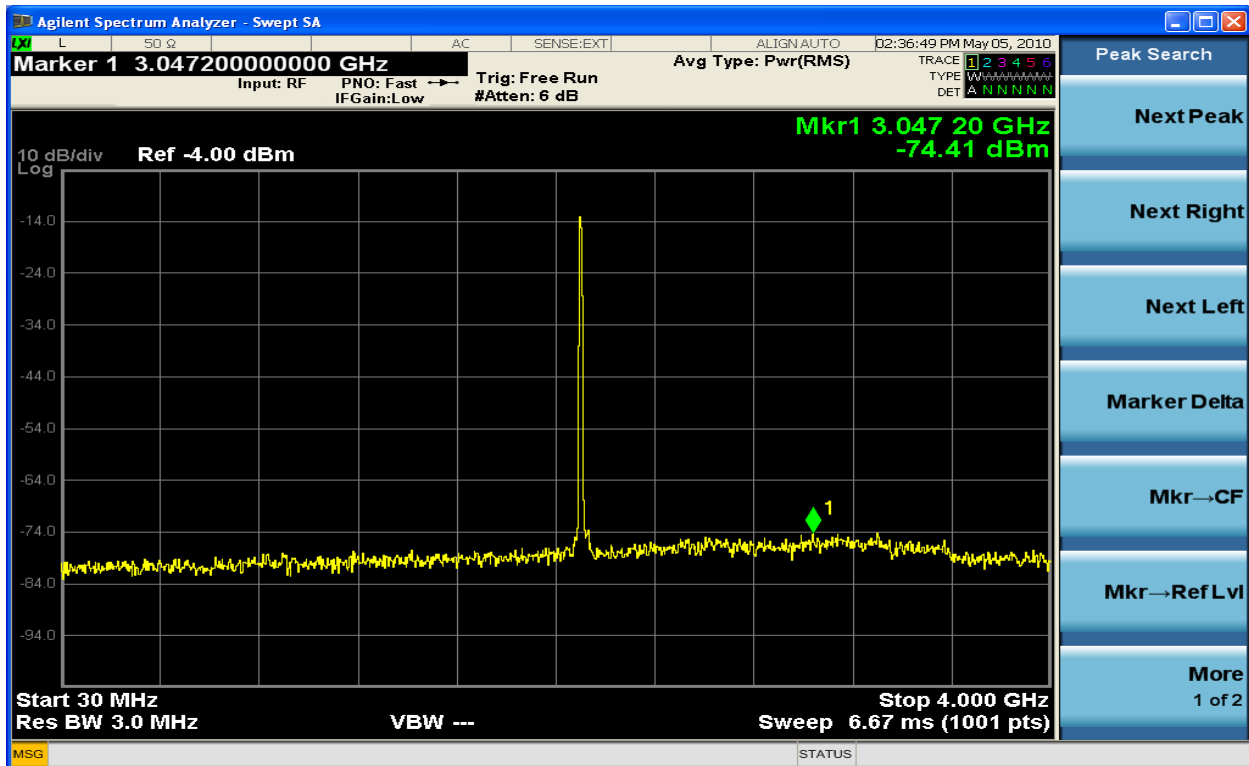

Figure 6-185 Spurious Emission TX1 64QAM 2115.0MHz - 10MHz (30MHz - 4GHz)

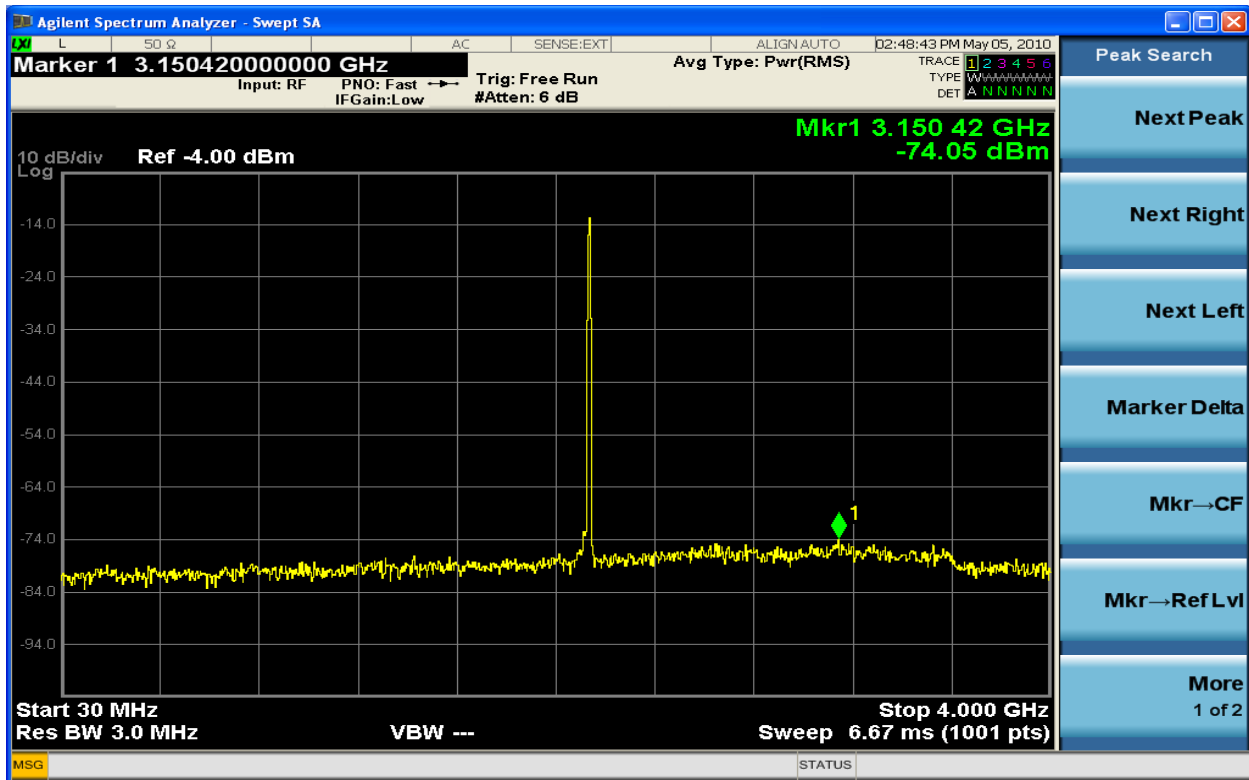

Figure 6-186 Spurious Emission TX1 64QAM 2150.0MHz - 10MHz (30MHz - 4GHz)

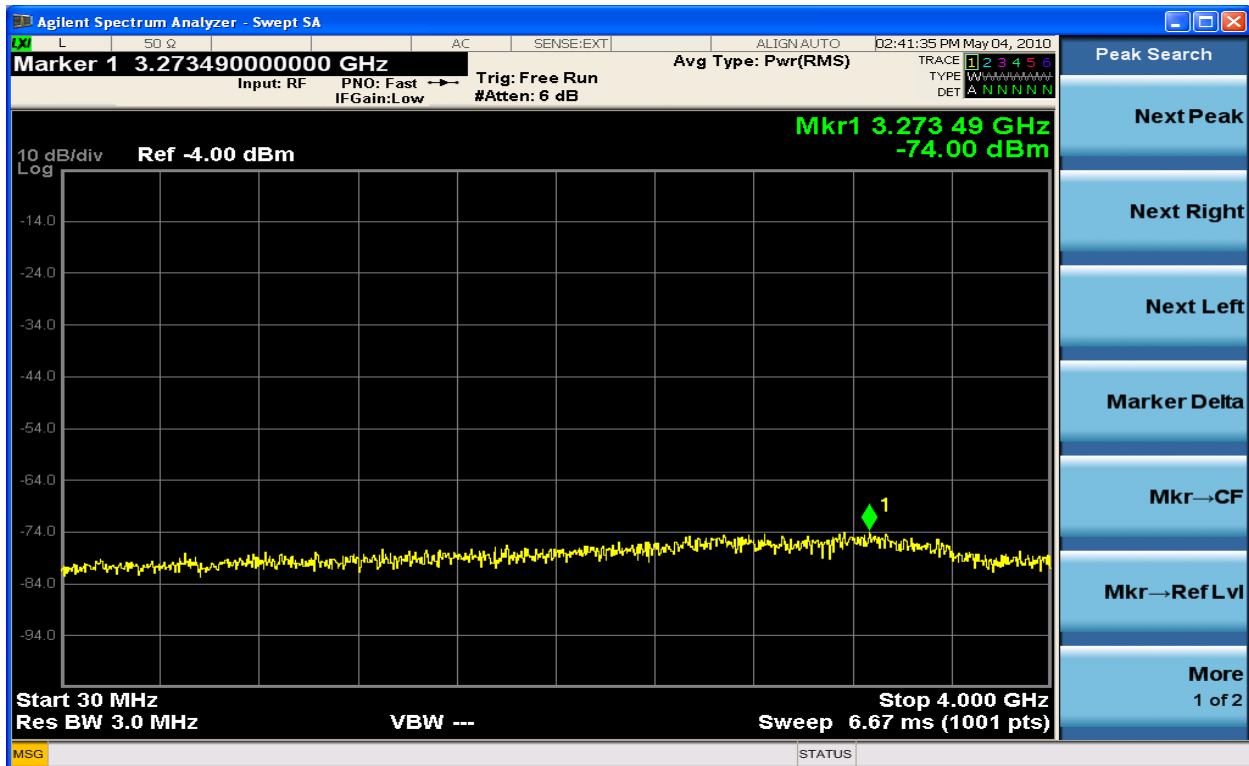

Figure 6-187 MXA (TX2) Noise Floor Reference (30MHz - 4GHz)

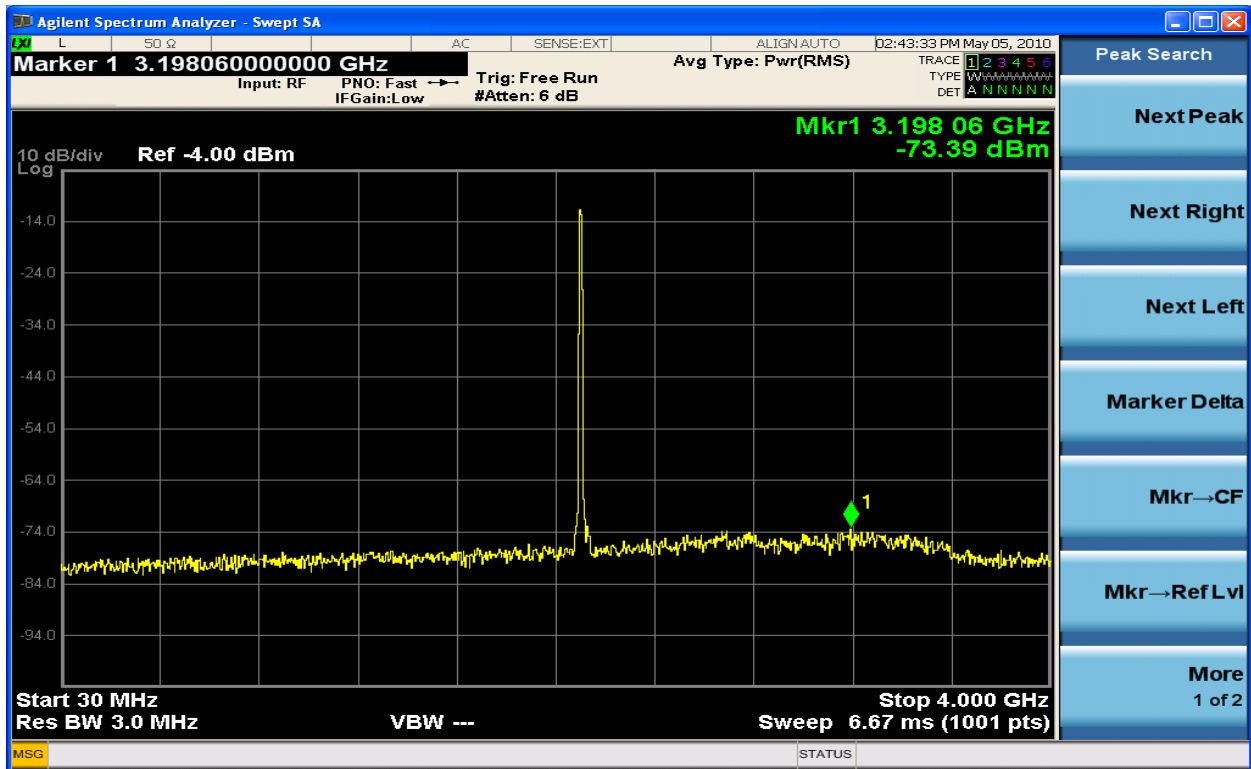

Figure 6-188 Spurious Emission TX2 64QAM 2115.0MHz - 10MHz (30MHz - 4GHz)

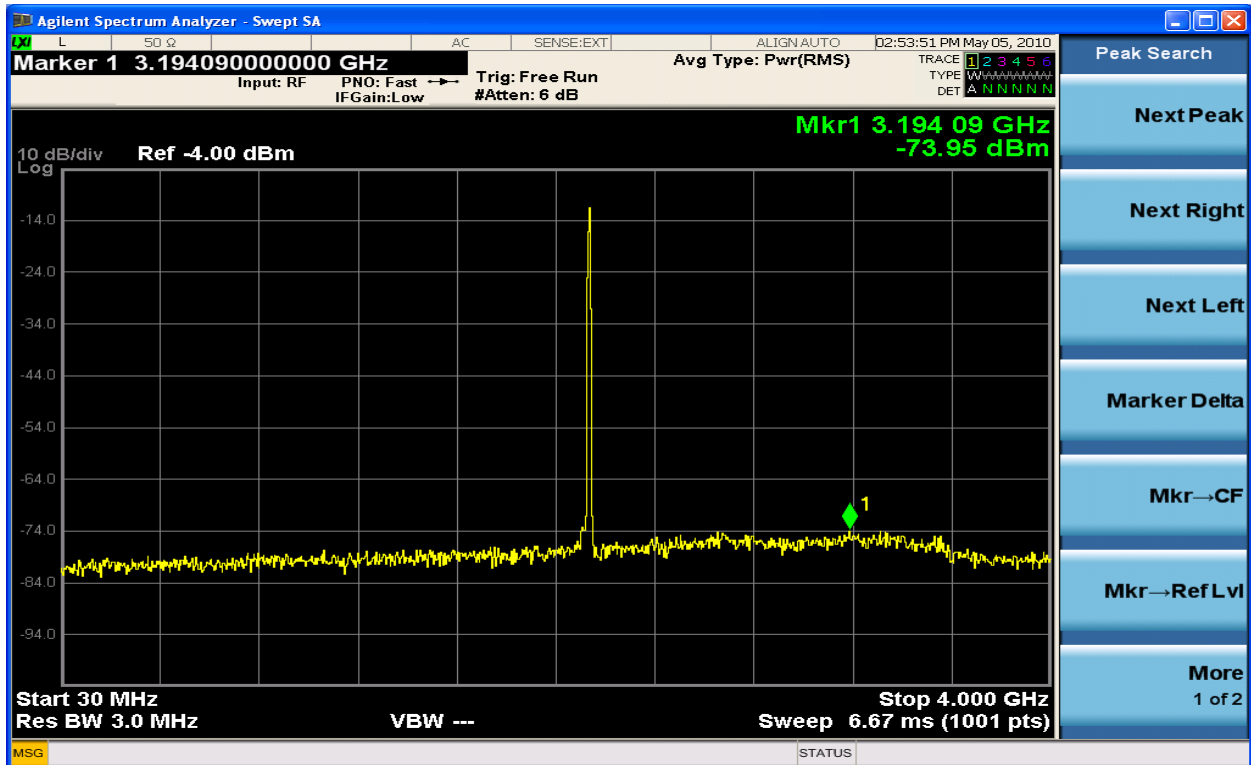

Figure 6-189 Spurious Emission TX2 64QAM 2150.0MHz - 10MHz (30MHz - 4GHz)

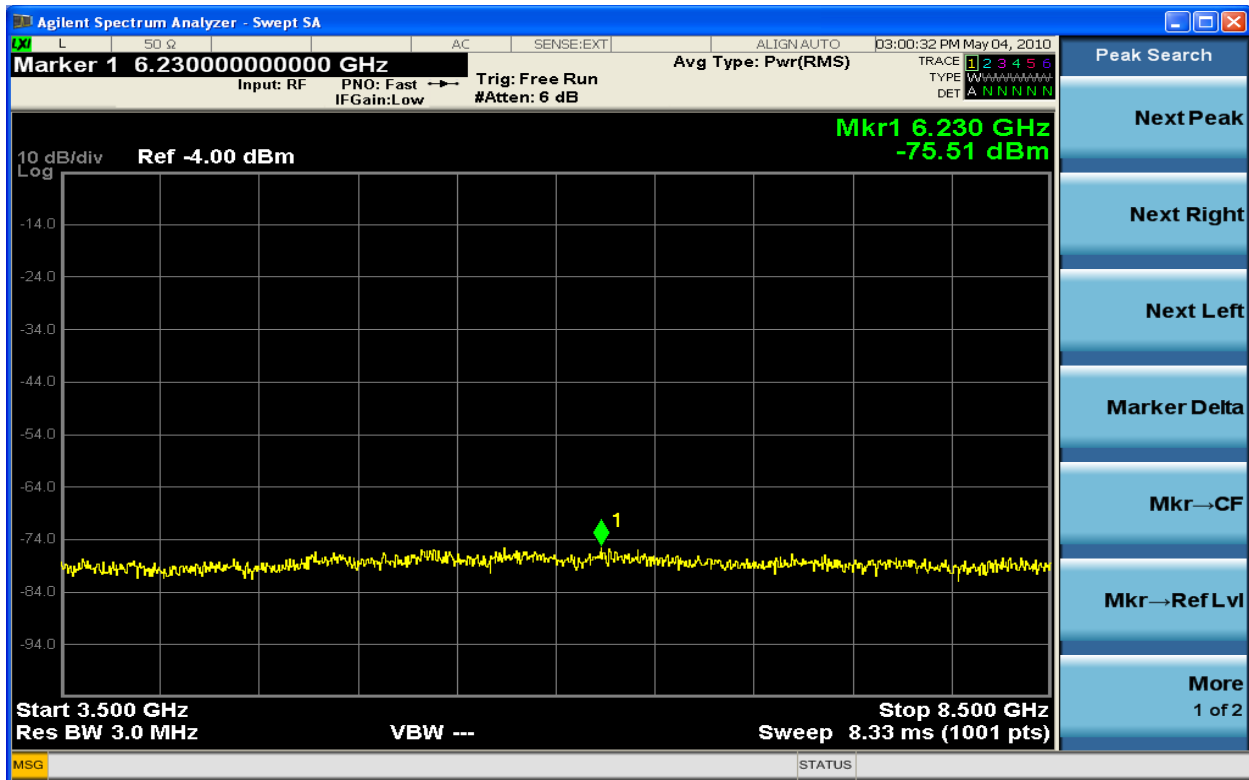

Figure 6-190 MXA (TX1) Noise Floor Reference (3.5GHz – 8.4GHz)

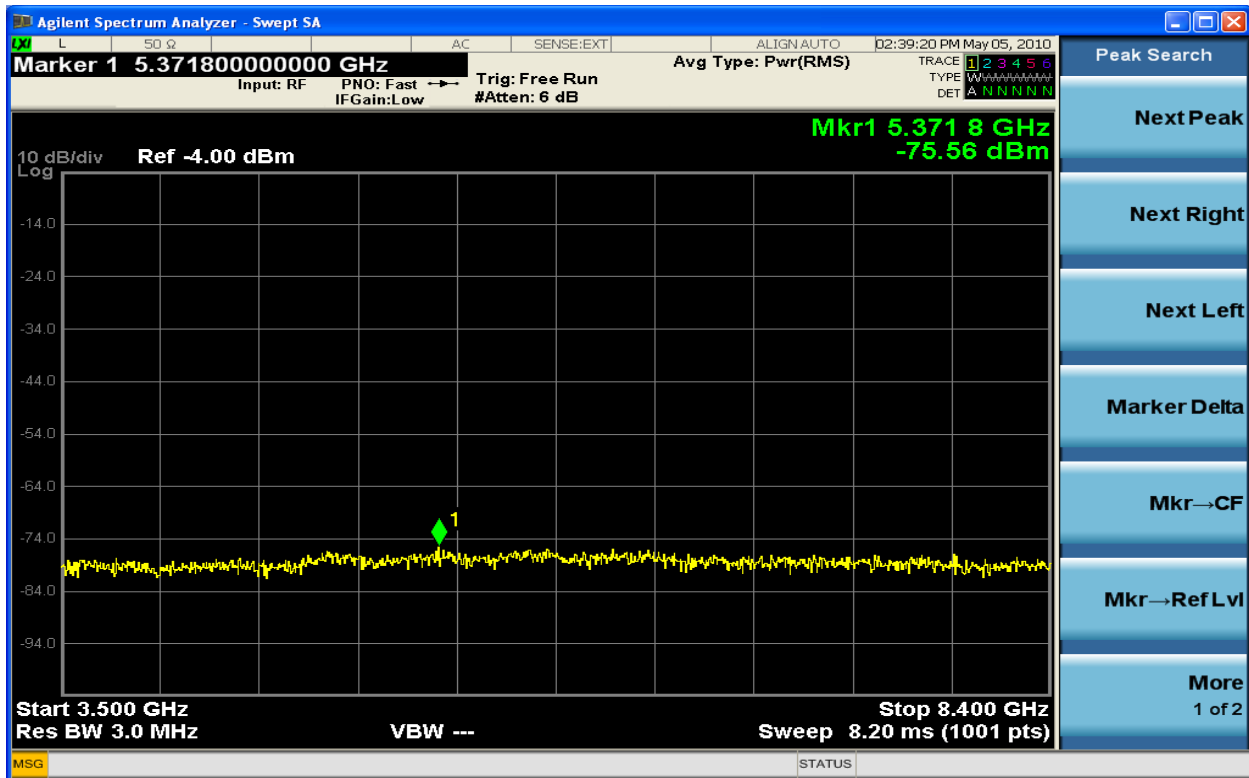

Figure 6-191 Spurious Emission TX1 64QAM 2115.0MHz - 10MHz (3.5GHz – 8.4GHz)



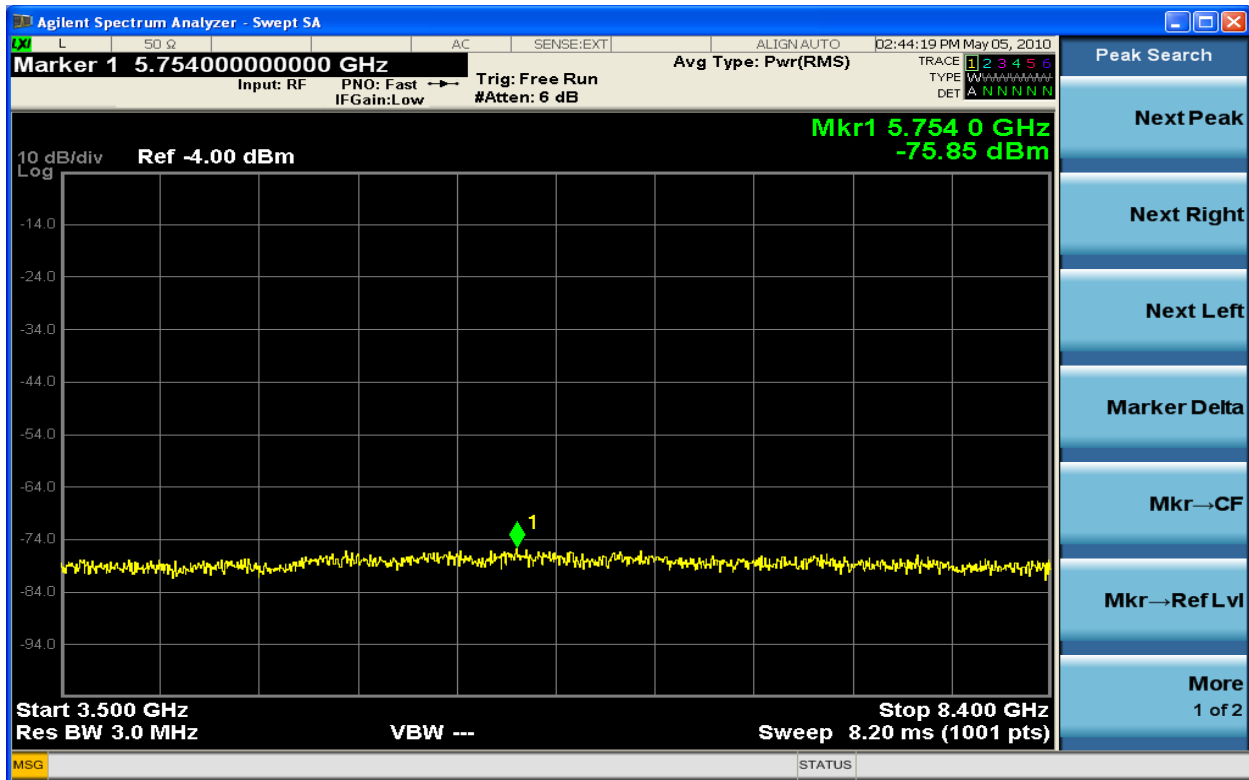

Figure 6-192 Spurious Emission TX1 64QAM 2150.0MHz - 10MHz (3.5GHz – 8.4GHz)

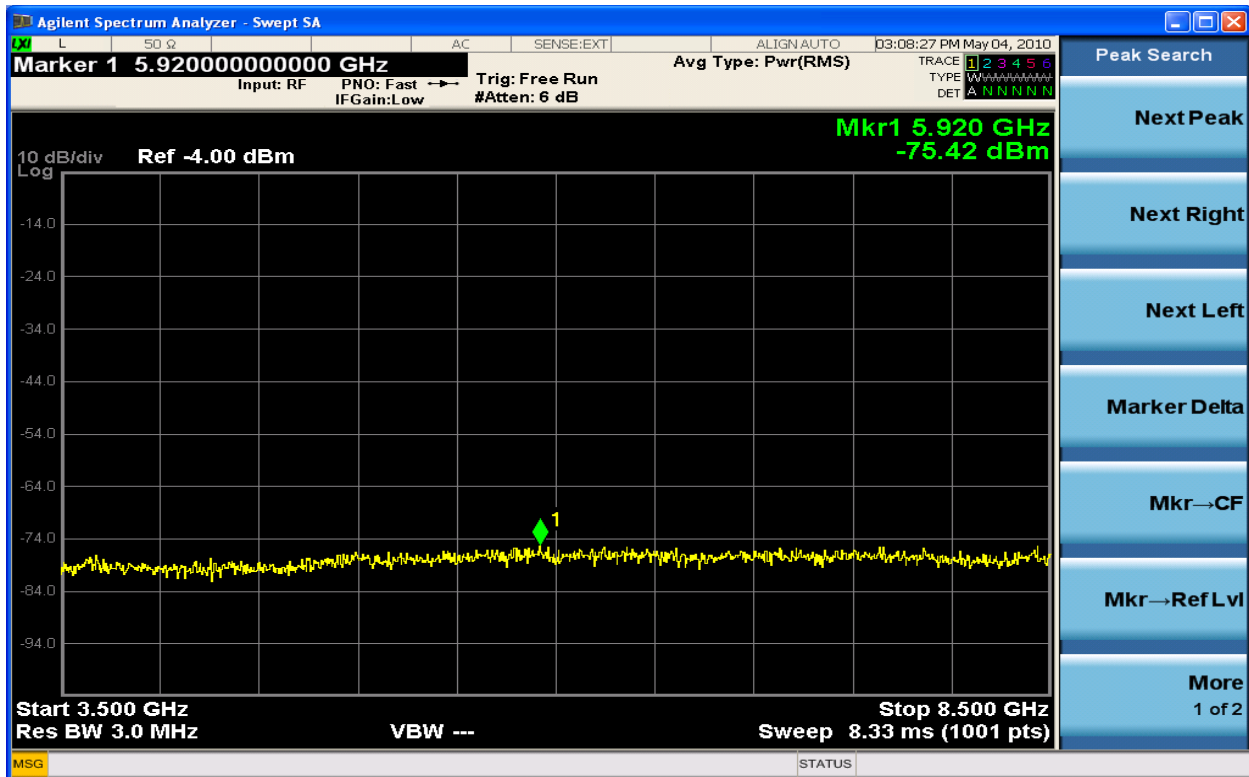

Figure 6-193 MXA (TX2) Noise Floor Reference (3.5GHz – 8.4GHz)

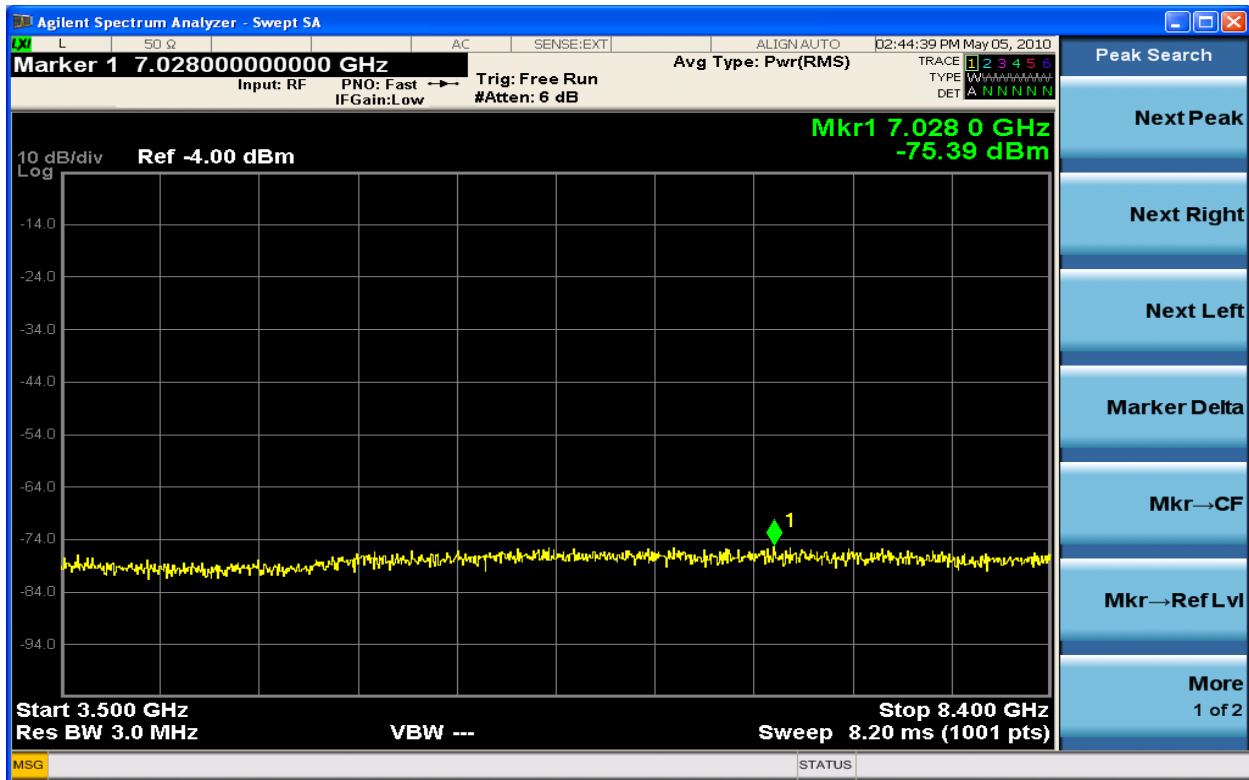

Figure 6-194 Spurious Emission TX2 64QAM 2115.0MHz - 10MHz (3.5GHz – 8.4GHz)

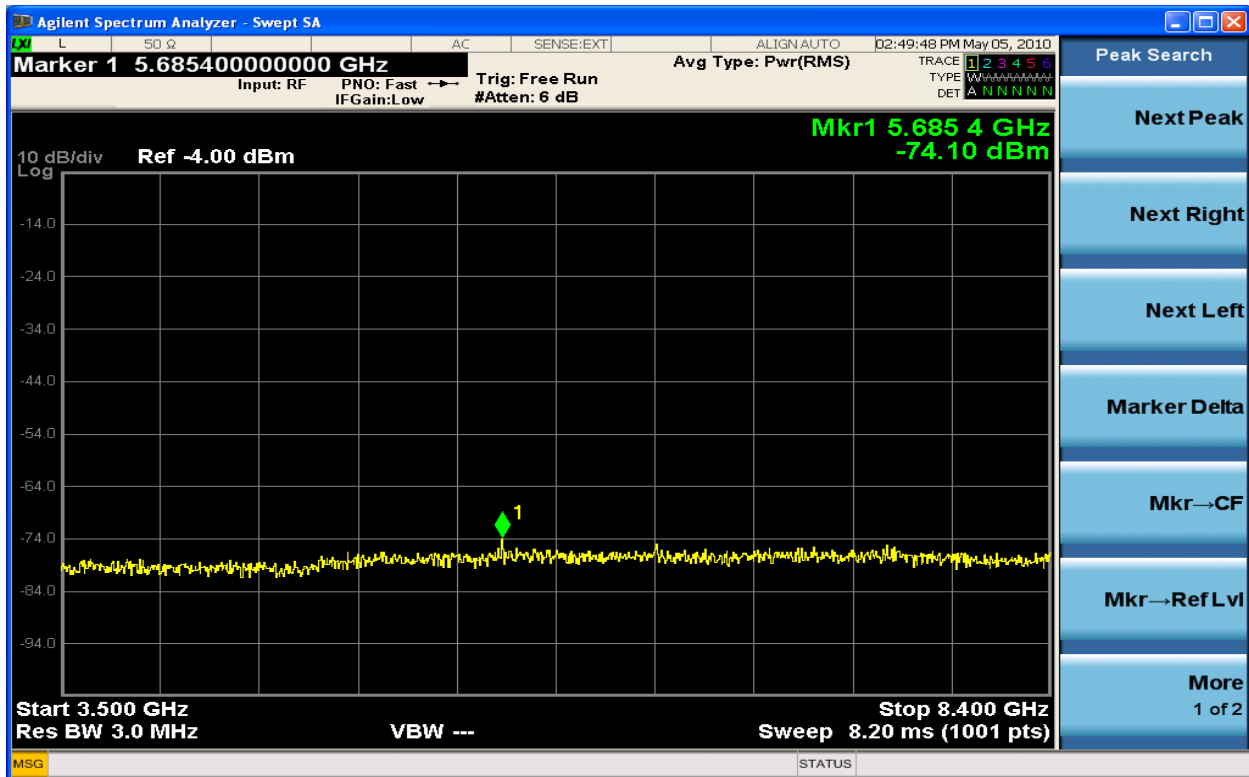

Figure 6-195 Spurious Emission TX2 64QAM 2150.0MHz – 10MHz (3.5GHz – 8.4GHz)



Figure 6-196 MXA (TX1) Noise Floor Reference (8GHz- 16GHz)



Figure 6-197 Spurious Emission TX1 64QAM 2115.0MHz - 10MHz (8GHz- 16GHz)

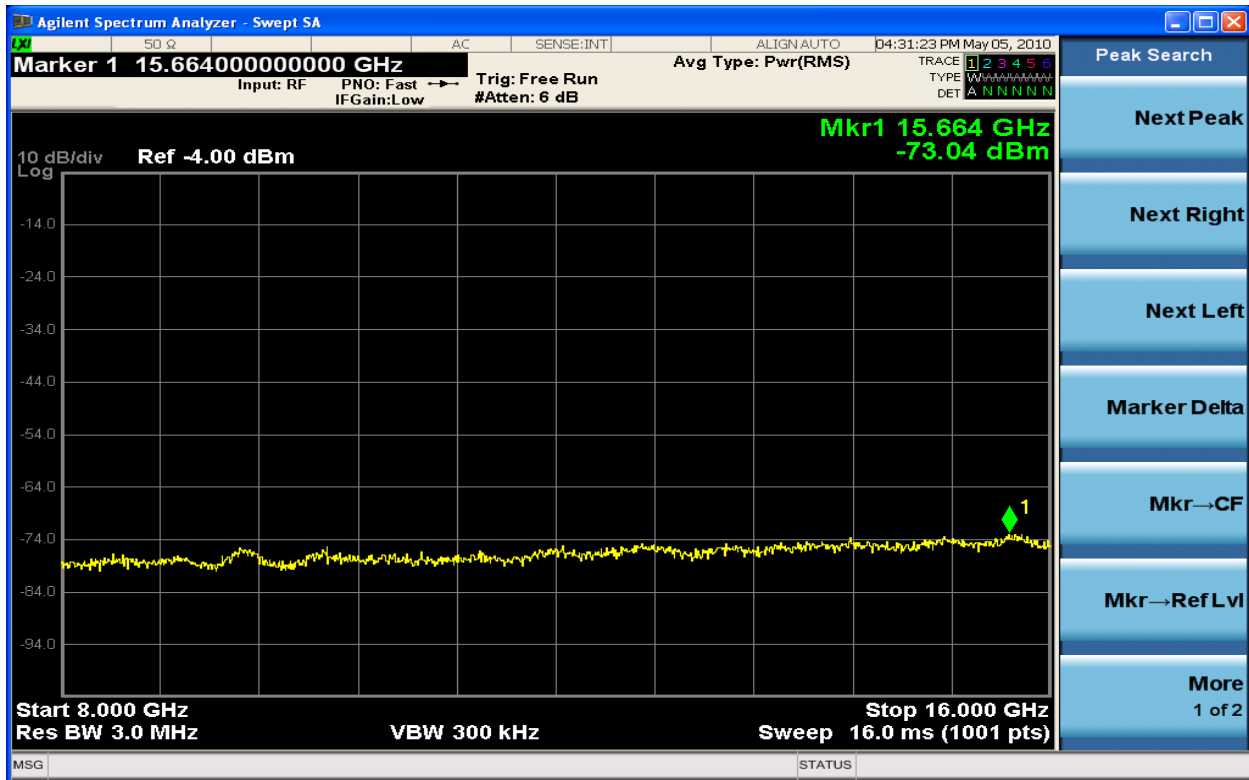

Figure 6-198 Spurious Emission TX1 64QAM 2150.0MHz – 10MHz (8GHz- 16GHz)

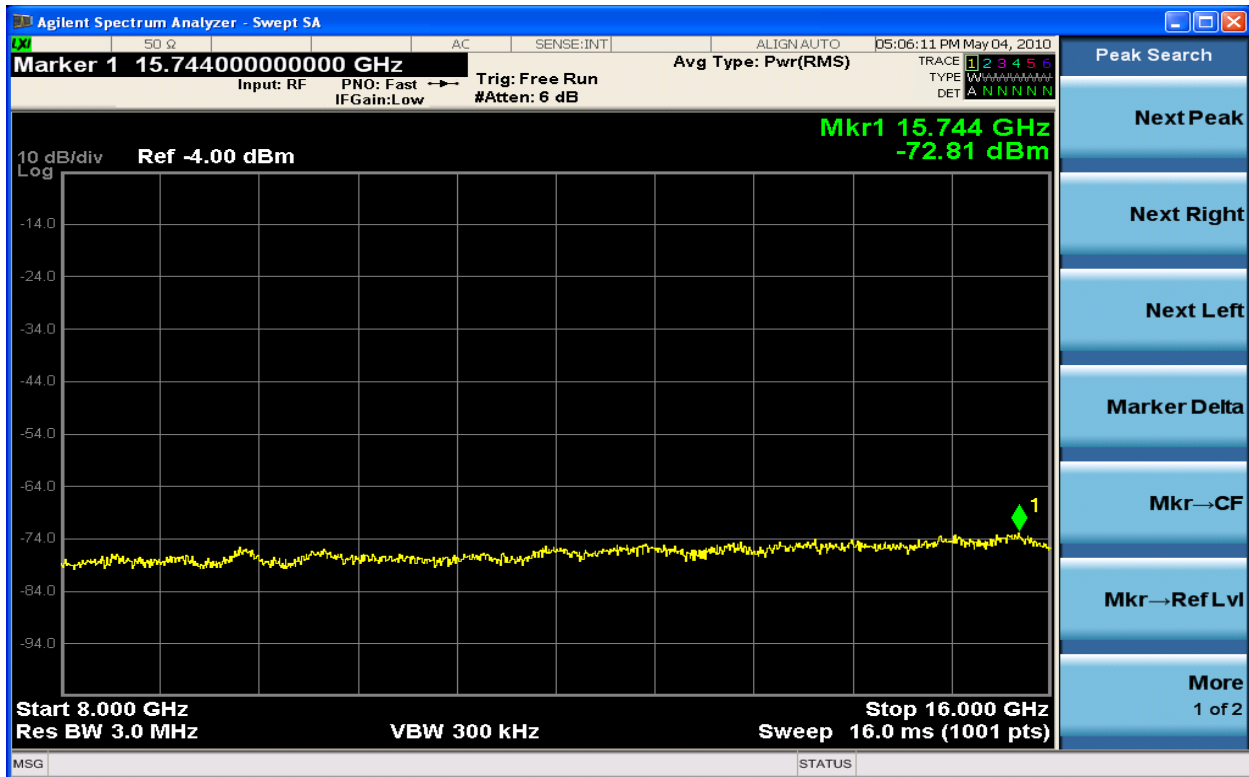

Figure 6-199 MXA (TX2) Noise Floor Reference (8GHz- 16GHz)



Figure 6-200 Spurious Emission TX2 64QAM 2115.0MHz - 10MHz (8GHz- 16GHz)

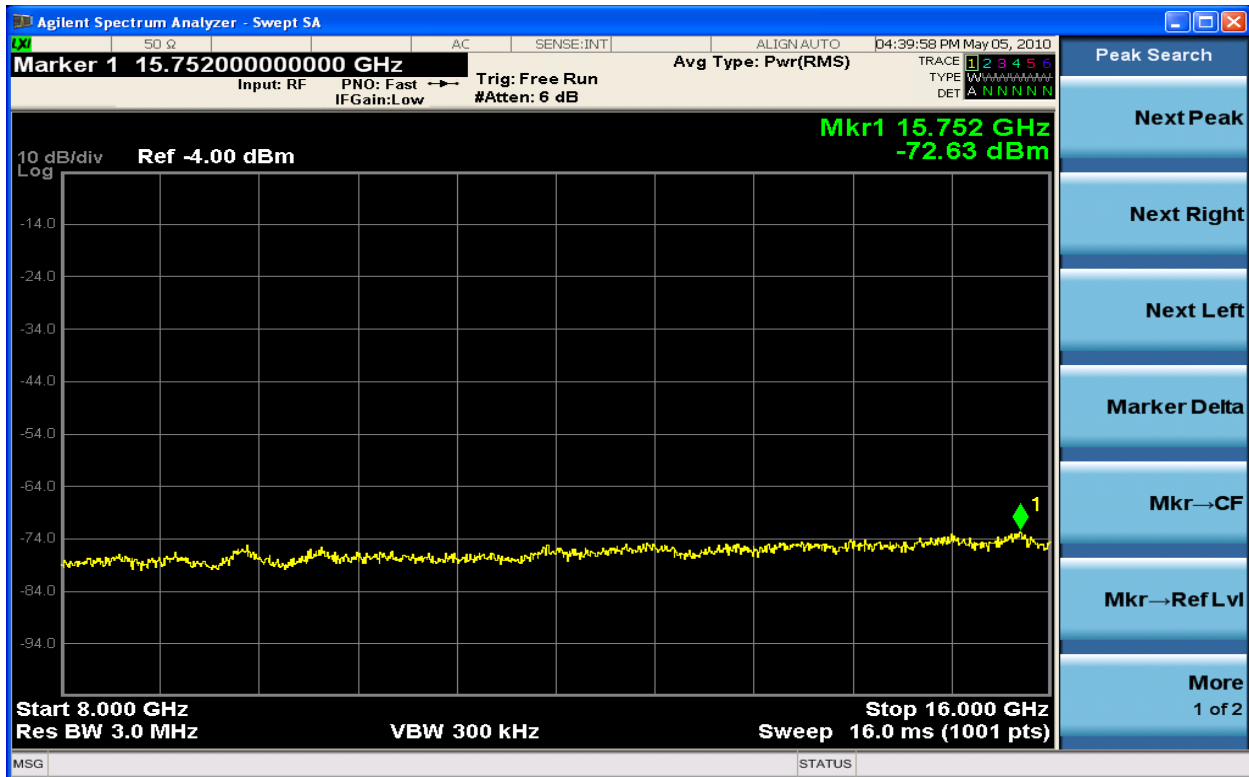

Figure 6-201 Spurious Emission TX2 64QAM 2150.0MHz - 10MHz (8GHz- 16GHz)



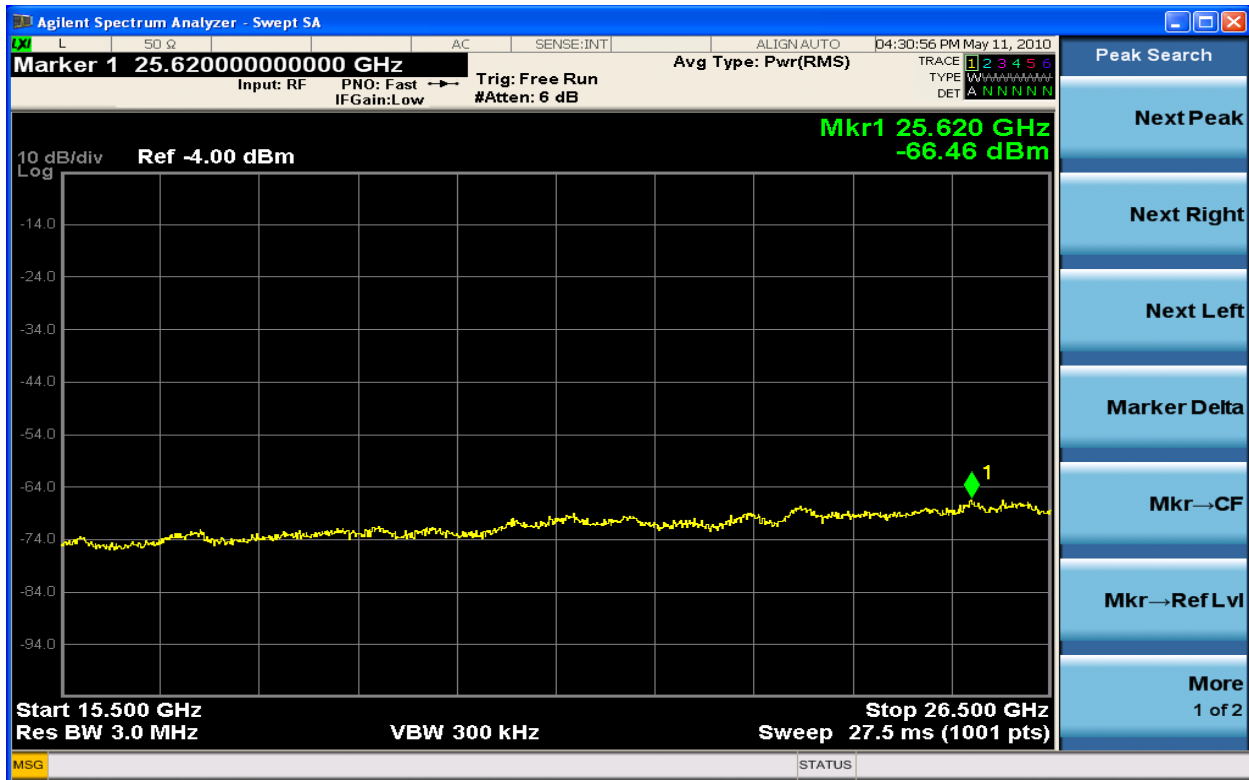

Figure 6-202 MXA (TX1) Noise Floor Reference (15.5GHz – 26.5GHz)

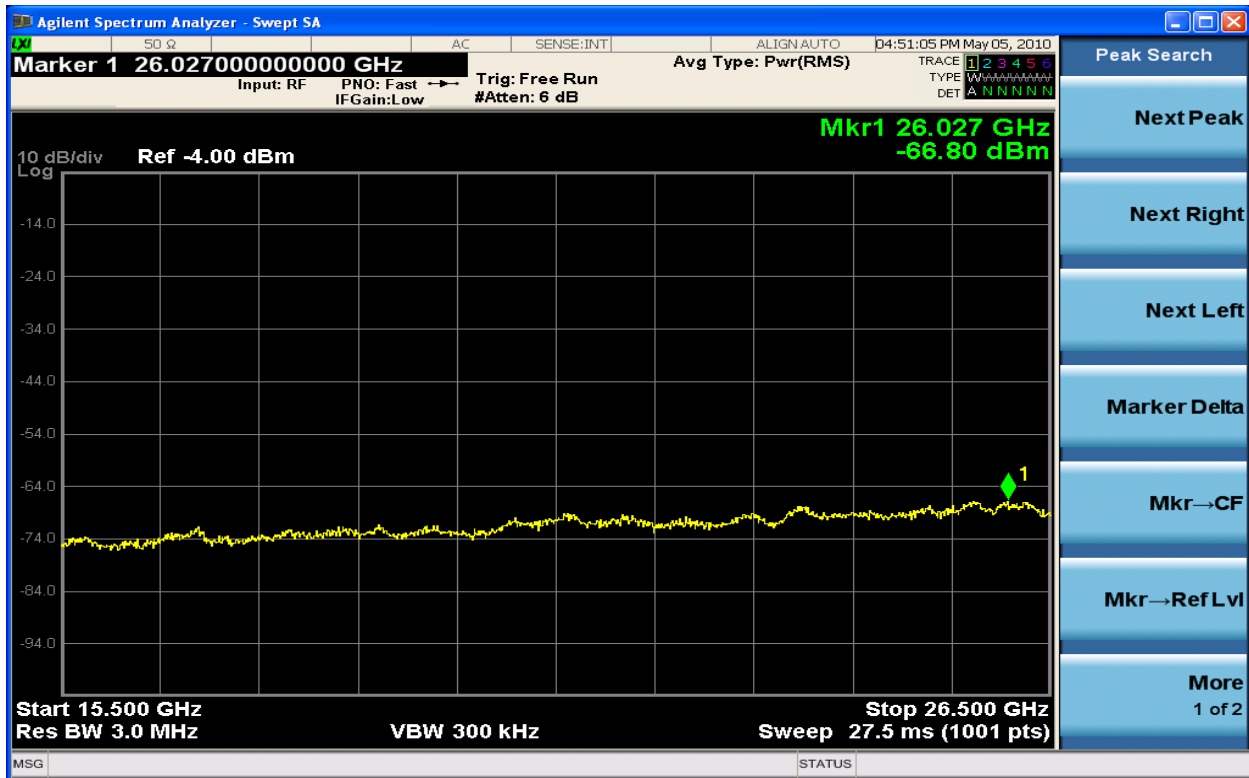

Figure 6-203 Spurious Emission TX1 64QAM 2115.0MHz - 10MHz (15.5GHz – 26.5GHz)

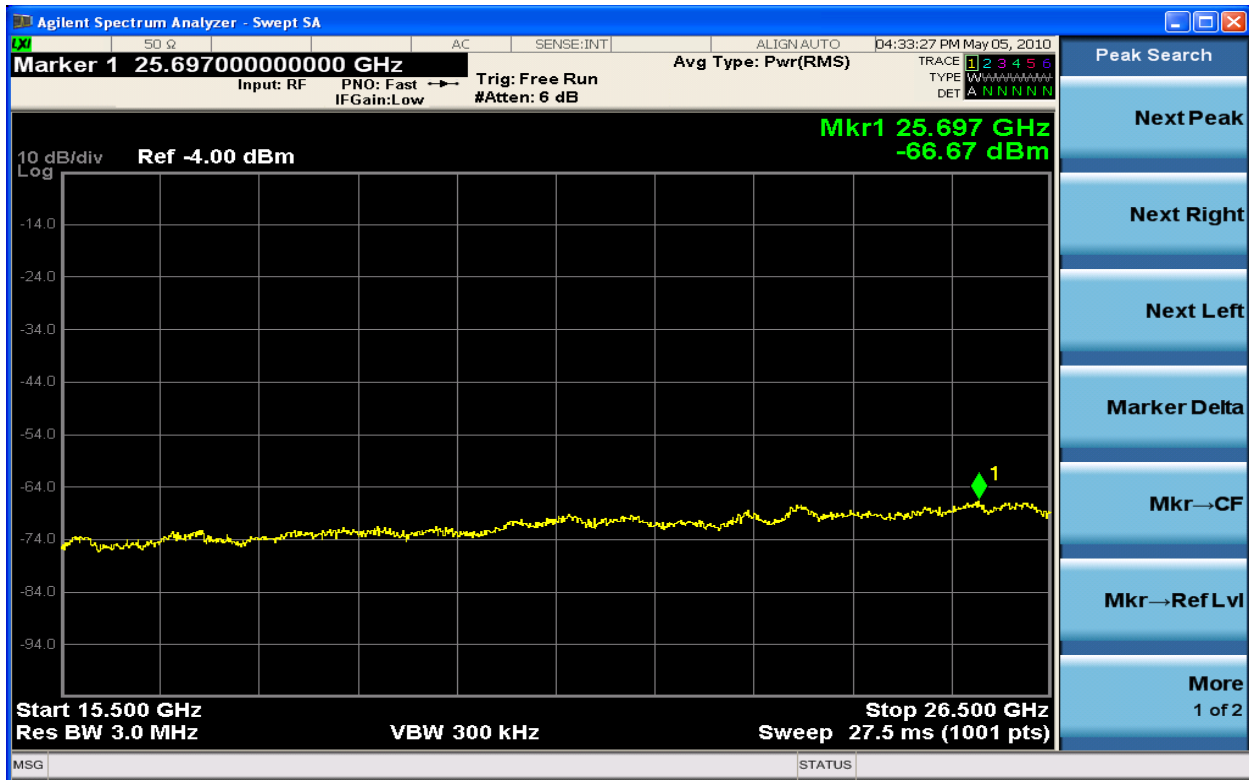

Figure 6-204 Spurious Emission TX1 64QAM 2150.0MHz – 10MHz (15.5GHz – 26.5GHz)

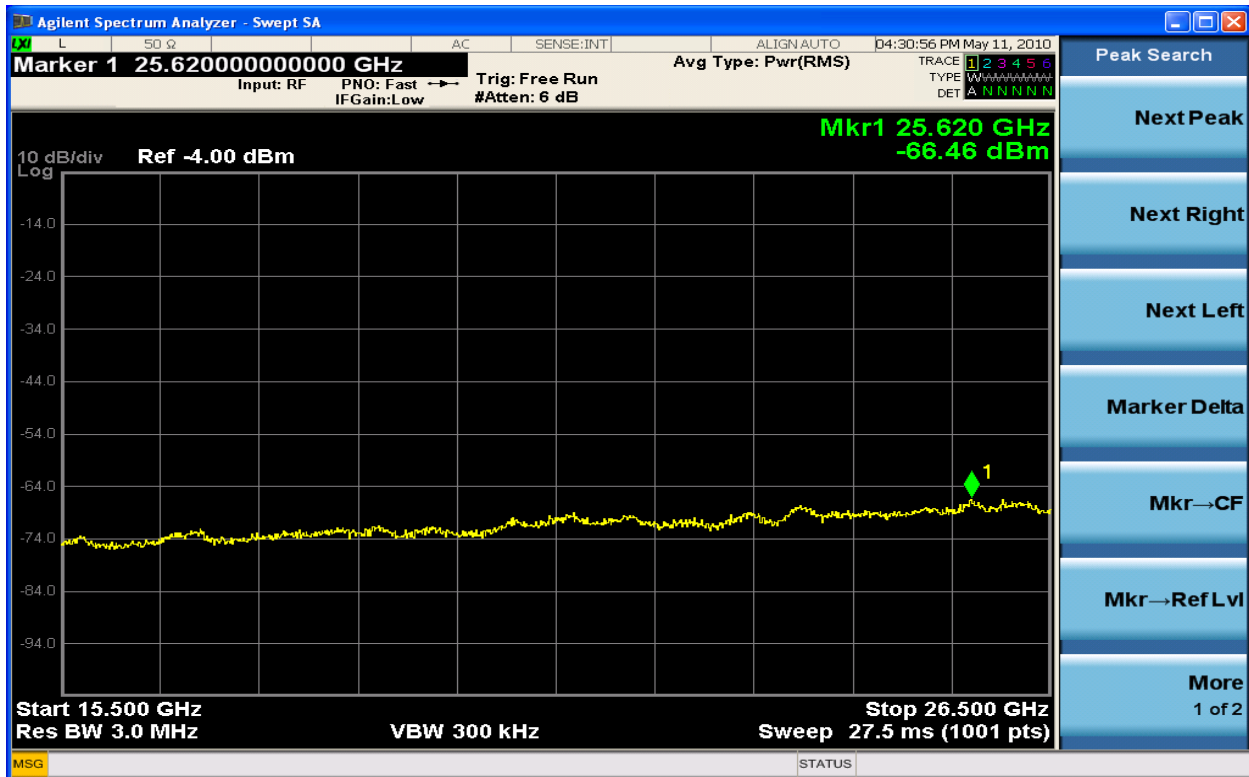

Figure 6-205 MXA (TX2) Noise Floor Reference (15.5GHz – 26.5GHz)

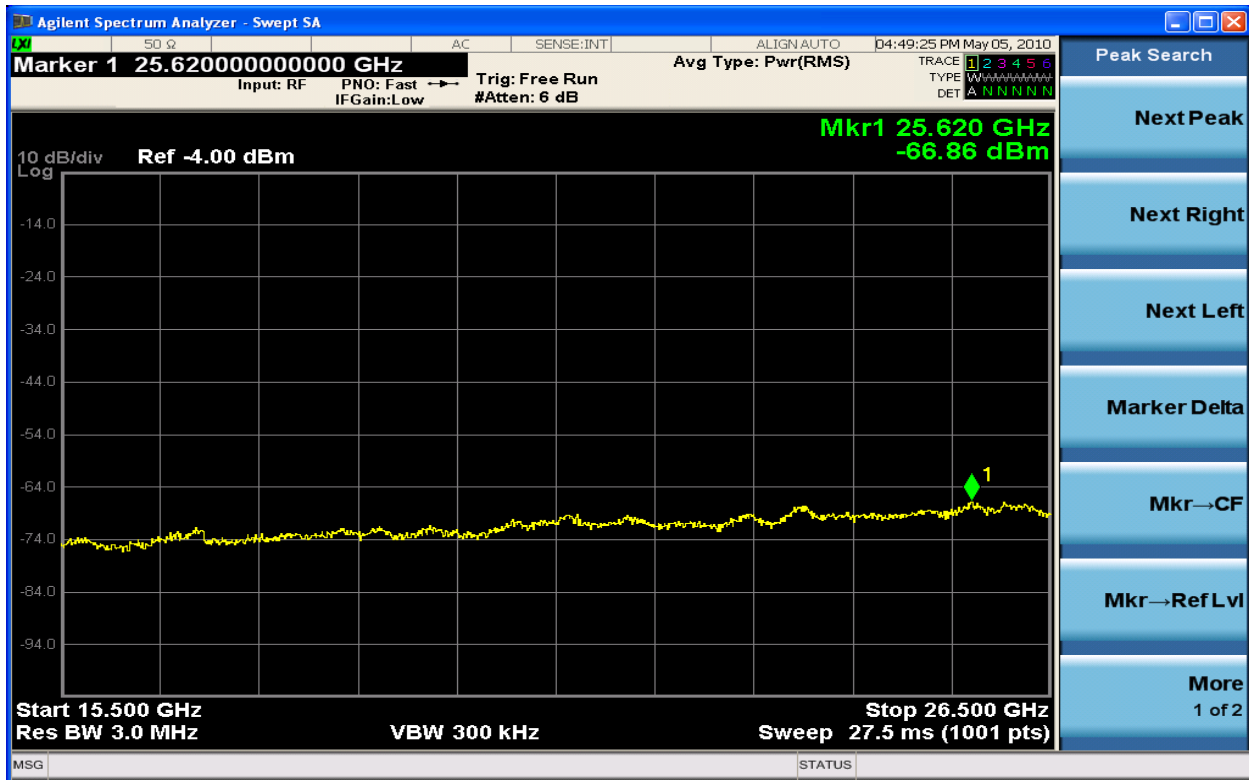

Figure 6-206 Spurious Emission TX2 64QAM 2115.0MHz - 10MHz (15.5GHz – 26.5GHz)

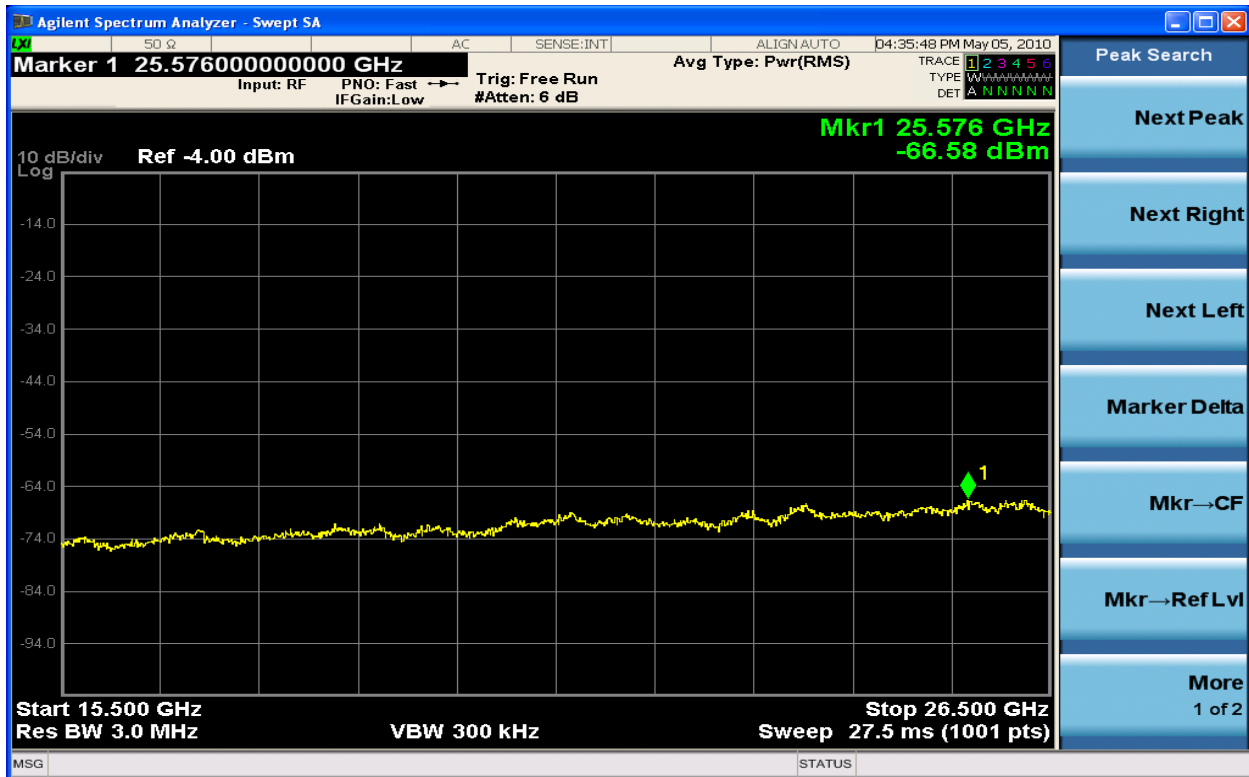

Figure 6-207 Spurious Emission TX2 64QAM 2150.0MHz – 10MHz (15.5GHz – 26.5GHz)

## 6.5 Field Strength of Spurious Radiation

### Clause 27.53(h)

(h) For operations in the 1710–1755 MHz and 2110–2155 MHz bands, the power of any emission outside a licensee’s frequency block shall be attenuated below the transmitter power (P) by at least  $43 + 10 \log_{10}(P)$  dB.

(1) Compliance with this provision is based on the use of measurement instrumentation employing a resolution bandwidth of 1 megahertz or greater. However, in the 1 megahertz bands immediately outside and adjacent to the licensee’s frequency block, a resolution bandwidth of at least one percent of the emission bandwidth of the fundamental emission of the transmitter may be employed. The emission bandwidth is defined as the width of the signal between two points, one below the carrier center frequency and one above the carrier center frequency, outside of which all emissions are attenuated at least 26 dB below the transmitter power.

(2) When measuring the emission limits, the nominal carrier frequency shall be adjusted as close to the licensee’s frequency block edges, both upper and lower, as the design permits.

(3) The measurements of emission power can be expressed in peak or average values, provided they are expressed in the same parameters as the transmitter power.

(i) When an emission outside of the authorized bandwidth causes harmful interference, the Commission may, at its discretion, require greater attenuation than specified in this section.

### Test Setup:

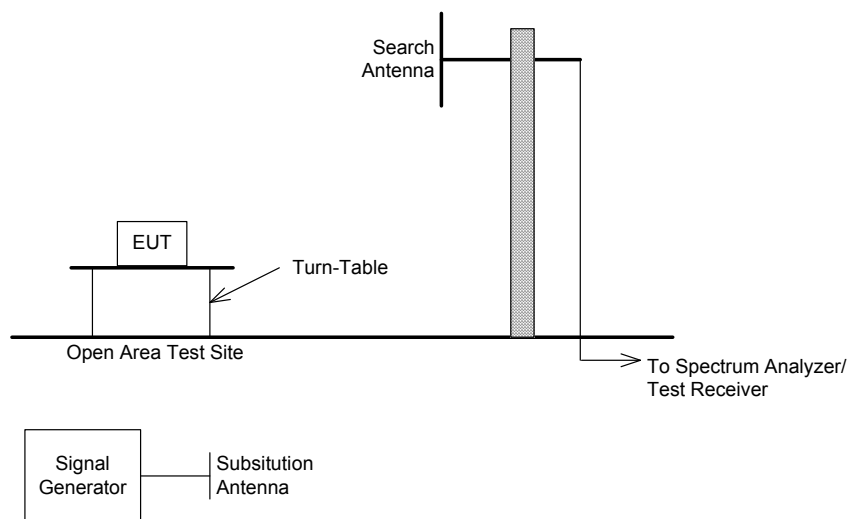

Figure 6-208 RRU Field Strength Set Up / Configuration

## Test Procedure

- The EUT was placed on a turntable inside the AFC (configured as in normal operation). The system and its cables were separated from the ground plane by an insulating support 10 mm in height. The system was grounded in accordance with its installation specifications. No additional grounding connections were connected.
- For tests between **30 MHz and 1 GHz** the receive antenna (bi-log/horn) was placed at 10 m away from the EUT. An initial scan was done to find emissions (frequencies) requiring detailed measurement. The pre-scan was done by rotating the system 360 degrees while recording all emissions (frequency and amplitude). This procedure was repeated for antenna heights of 1 to 4 m, and for horizontal and vertical polarizations of the receiving antenna. The detector mode was quasi-peak (QP) with a 120 kHz bandwidth unless otherwise noted.
- For tests between **1 GHz and 10 GHz** the receive antenna (bi-log/horn) was placed at 10 m away from the EUT. An initial scan was done to find emissions (frequencies) requiring detailed measurement. The pre-scan was done by rotating the system 360 degrees while recording all emissions (frequency and amplitude). This procedure was repeated for antenna heights of 1 to 4 m, and for horizontal and vertical polarizations of the receiving antenna. The detector mode was average (AVG) with a 1 MHz bandwidth unless otherwise noted.
- For tests between **10 GHz to 18 GHz** the receive horn antenna was placed at a 3 m distance from the EUT. An initial scan was done to find emissions (frequencies) requiring detail measurement. The pre-scan was done by rotating the system 360 degrees while recording all emissions (frequency and amplitude). This procedure was repeated for antenna heights of 1 to 4 m, and for horizontal and vertical polarizations of the receiving antenna. These measurements were made with an average detector mode (AVG) with a 1 MHz bandwidth unless otherwise noted.
- For **all the above frequency ranges** optimization was done based on the pre-scan data. For each identified frequency, the EUT was rotated in azimuth over 360 degrees and the direction of maximum emission was noted. Antenna height was then varied from 1 to 4 m at this azimuth to obtain maximum emissions. The procedure was repeated for both horizontal and vertical polarizations (where applicable) of the search antenna. The maximum level measured was recorded. The spectrum analyzer was verified to make sure it was not saturating in the presence of the radio signal.
- The highest emissions were re-evaluated using the substitution method. This is accomplished by replacing the EUT by a calibrated antenna, cable and signal generator. This equipment is used to transmit a signal that will generate a RF meter reading level identical to the one were done with a bandwidth of 1 MHz.



### Calculation of the Compliance Margin

The following example illustrates the manner in which the emissions levels are calculated in the “RE Test Results” Table 6-9 Spurious Emissions ERP.

The rows in these tables are defined as follows.

Meter Reading (dBuV) =	Voltage measured using the spectrum analyzer with quasi-peak adapter
Gain/Loss Factor (dB) =	Cumulative gain or loss of pre-amplifier and cables used in the measurement path (a negative value indicates gain)
Transducer Factor (dB) =	Antenna factor
Level (dBuV/m) =	Corrected value or field strength, that is, the parameter of interest that is compared to the limit
Margin (dB) =	Level with respect to the appropriate limit (a positive Margin indicates that the Level is below the limit and that the measurement is a PASS)

The values in the Level row are calculated as follows:

$$\text{Level} = \text{Meter Reading} + \text{Gain/Loss Factor} + \text{Transducer Factor}$$

The values in the Margin row are calculated as follows:

$$\text{Margin} = \text{Limit} - \text{Level}$$

The following example shows the manner in which the compliance margin is calculated for ERP:

ERP = Effective radiated power or equivalent radiated power

$$\text{ERP} = \text{Signal generator level} - \text{Cable losses} + \text{Antenna gain} - \text{Half wave dipole gain}$$

$$\text{Margin} = \text{Limit} - \text{ERP}$$

$$\text{Limit} = \text{EUT Rated Power} - \text{Attenuation}$$

$$\text{Attenuation} = (43 + 10 \text{ Log} (\text{Pwr}))$$

$$\text{Limit} = 10 \text{ log} (30\text{Watt}) - (43 + 10 \text{ Log}(30\text{W}))$$

$$\text{Limit} = - 13 \text{ dBm}$$

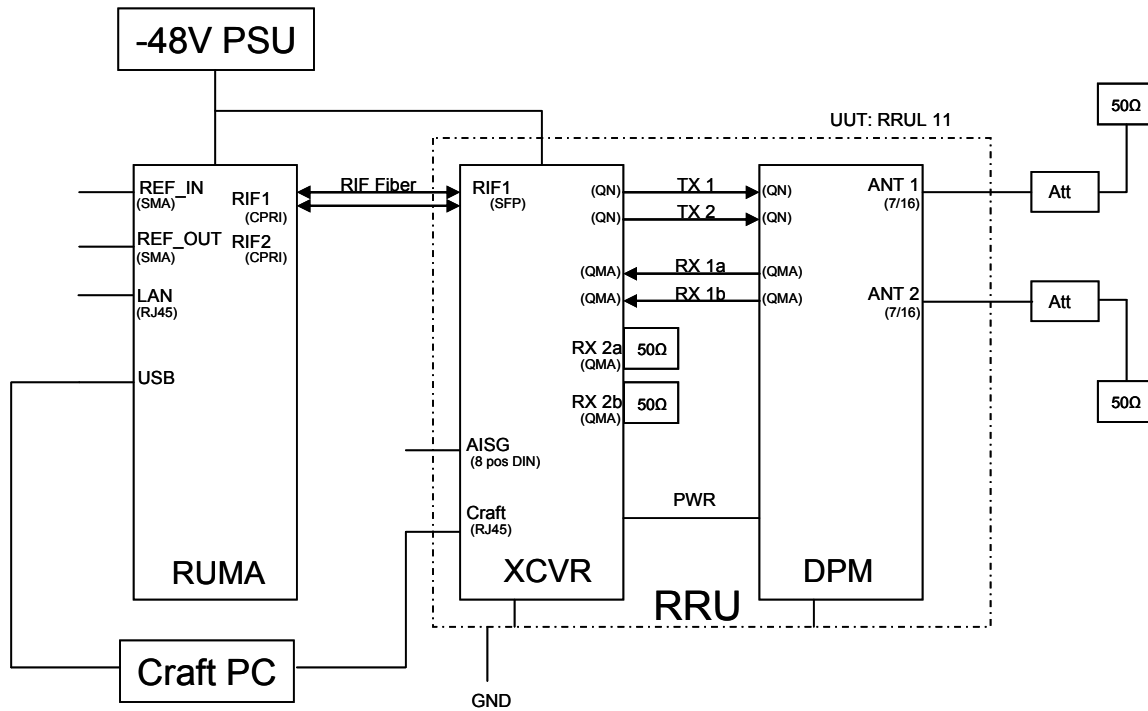

**Figure 6-209 RRU EMC Set Up / Configuration**

**FCC 2.1053:** Measurements required: Field strength of spurious radiation.

Measurements shall be made to detect spurious emissions that may be radiated directly from the cabinet, control circuits, power leads, or intermediate circuit elements under normal conditions of installation and operation. Curves or equivalent data shall be supplied showing the magnitude of each harmonic and other spurious emission. For this test, single sideband, independent sideband, and controlled carrier transmitters shall be modulated under the conditions specified in paragraph (c) of FCC 2.1049, as appropriate.

**FCC 2.1057:** Frequency spectrum to be investigated.

In all of the measurements set forth in 2.1051 and 2.1053, the spectrum shall be investigated from the lowest radio frequency signal generated in the equipment, without going below 9 kHz, up to at least the tenth harmonic of the highest fundamental frequency or to 40 GHz, whichever is lower. Particular attention should be paid to harmonics and sub-harmonics of the carrier frequency as well as to those frequencies removed from the carrier by multiples of the oscillator frequency. Radiation at the frequencies of multiplier stages should also be checked. The amplitude of spurious emissions which are attenuated more than 20 dB below the permissible value need not be reported.

**27.55 Power Strength Limits.**

(a) *Field strength limits:* For the following bands, the predicted or measured median field strength at any location on the geographical border of a licensee’s service area shall not exceed the value specified unless the adjacent affected service area licensee(s) agree(s) to a different field strength. This value applies to both the initially offered service areas and to partitioned service areas.

- (1) 2110–2155, 2305–2320 and 2345–2360 MHz bands: 47 dBV/m.

EMC Reference Report: K0001782-TR-EMC-01-A01, 03 June 2010

Flextronics Design Validation Centre, 21 Richardson Side Road, Kanata On, K2K 2C1, Canada

Accreditation: SCC ISO/IEC 17025

**Table 6-9 Spurious Emissions ERP**

Frequency (MHz)	Field Strength (dBuV)	Signal Substitution (dBm)	Cable Loss (dB)	Antenna Gain (dBi)	dBi to dBd Conversion	ERP (dBm)	Limit (dBm)	Margin (dB)
88.8833	40.0	-68.56	1.09	-0.11	2.15	-72.0	-13.0	59.0
4268.488	49.7	-48.54	7.89	10.68	2.15	-47.9	-13.0	34.9
6399.734	43.9	-48.45	10.0	11.71	2.15	-48.9	-13.0	35.9
17969.167	35.7	-36.54	17.44	6.49	2.15	-49.6	-13.0	36.7

Remarks: All other spurious have more margin

All emissions in the radiated emission scan were low compared to the FCC Part 15 limits. The worst case spurious emissions were verified using substitution method as tabulated above.



**Figure 6-210 Radiated Emissions Set Up Photo**

## 6.6 Frequency Stability

### Frequency Stability Clause 27.54

27.54 Frequency Stability. - The frequency stability shall be sufficient to ensure that the fundamental emissions stay within the authorized bands of operation.

### FCC Clause 2.1055 Frequency Stability

2.1055 Measurements required: Frequency stability.

- (a) The frequency stability shall be measured with variation of ambient temperature as follows:
  - (1) From  $-30^{\circ}$  to  $+50^{\circ}$  centigrade for all equipment except that specified in paragraphs (a)(2) and (3) of this section
- (b) Frequency measurements shall be made at the extremes of the specified temperature range and at intervals of not more than  $10^{\circ}$  centigrade through the range.
- (d) The frequency stability shall be measured with variation of primary supply voltage as follows:
  - (1) Vary primary supply voltage from 85 to 115 percent of the nominal value for other than hand carried battery equipment.

### Test Setup

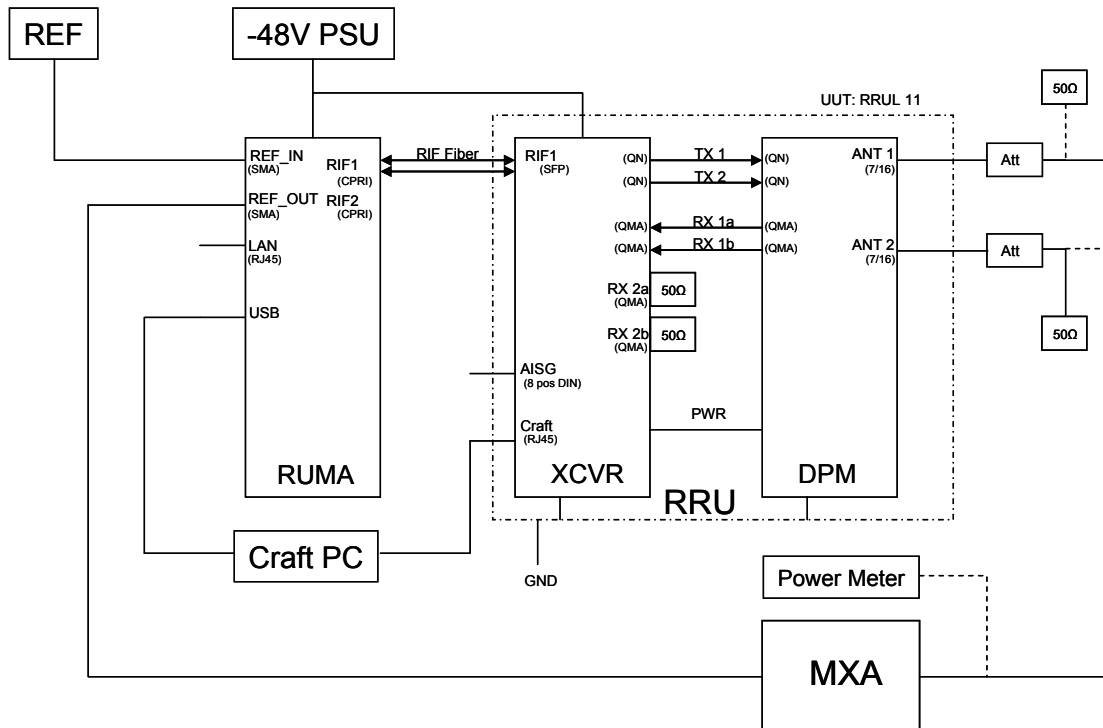

**Figure 6-211 RRU Stability Set Up / Configuration**

**Test Conditions:**

Extreme Temperature Condition: -30°C to 50°C

Extreme Voltage Conditions: ±15% of standard voltage condition.

**Settings Remarks**

1. The EUT would be operated and frequency offset / error monitored over the variables.
2. The EUT would be connected to a spectrum analyzer. The frequency stability would be determined by the frequency counter function of the spectrum analyzer.
3. Test would be conducted at the temperature range from -30°C to 50°C degree with 10°C intervals. Measurement would also be conducted with varying the primary supply voltage from 85% to 115% of the nominal value.
4. Tabulated results and plots are compiled and presented in this section.

**Table 6-10: Frequency Stability vs. Temperature / Voltage Variation**

Temperature (°C)	DC (V)	Frequency Error (Hz)	Time	Date
-30	40	-5.2030	17:30	06 May 2010
-30	48	-11.113	17:30	06 May 2010
-30	55	13.222	17:30	06 May 2010
-20	40	12.213	09:00	07 May 2010
-20	48	-1.6841	09:00	07 May 2010
-20	55	3.5470	09:00	07 May 2010
-10	40	15.872	10:00	07 May 2010
-10	48	-6.0710	10:00	07 May 2010
-10	55	-13.201	10:00	07 May 2010
0	40	3.7803	11:00	07 May 2010
0	48	5.1106	11:00	07 May 2010
0	55	11.550	11:00	07 May 2010
+10	40	6.9055	12:00	07 May 2010
+10	48	0.1139	12:00	07 May 2010
+10	55	7.5110	12:00	07 May 2010
+20	40	3.7602	13:00	07 May 2010
+20	48	6.1441	13:00	07 May 2010
+20	55	11.239	13:00	07 May 2010
+30	40	11.421	14:00	07 May 2010
+30	48	8.7464	14:00	07 May 2010
+30	55	-2.1100	14:00	07 May 2010
+40	40	4.3135	15:00	07 May 2010
+40	48	7.6271	15:00	07 May 2010
+40	55	-11.490	15:00	07 May 2010
+50	40	-9.2888	16:00	07 May 2010
+50	48	-13.393	16:00	07 May 2010
+50	55	3.3176	16:00	07 May 2010



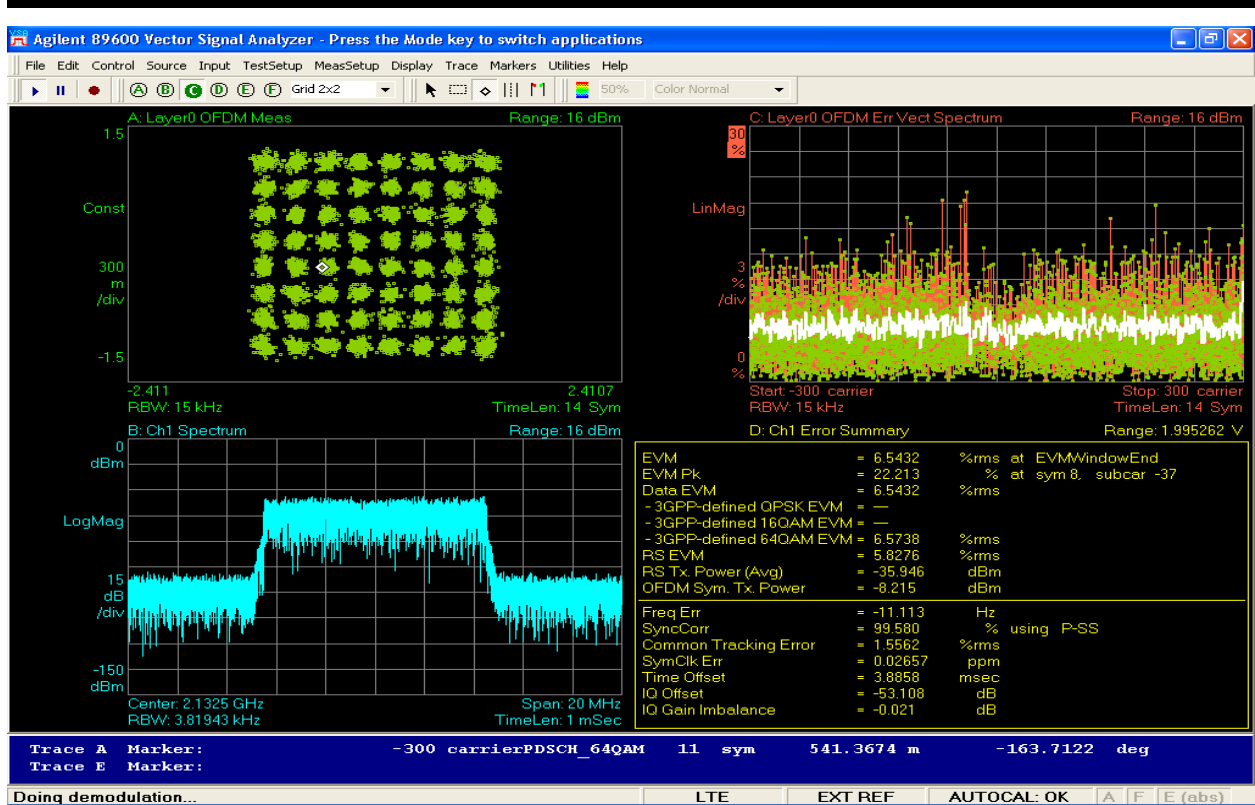

Figure 6-212 Stability - 10MHz @ -30C

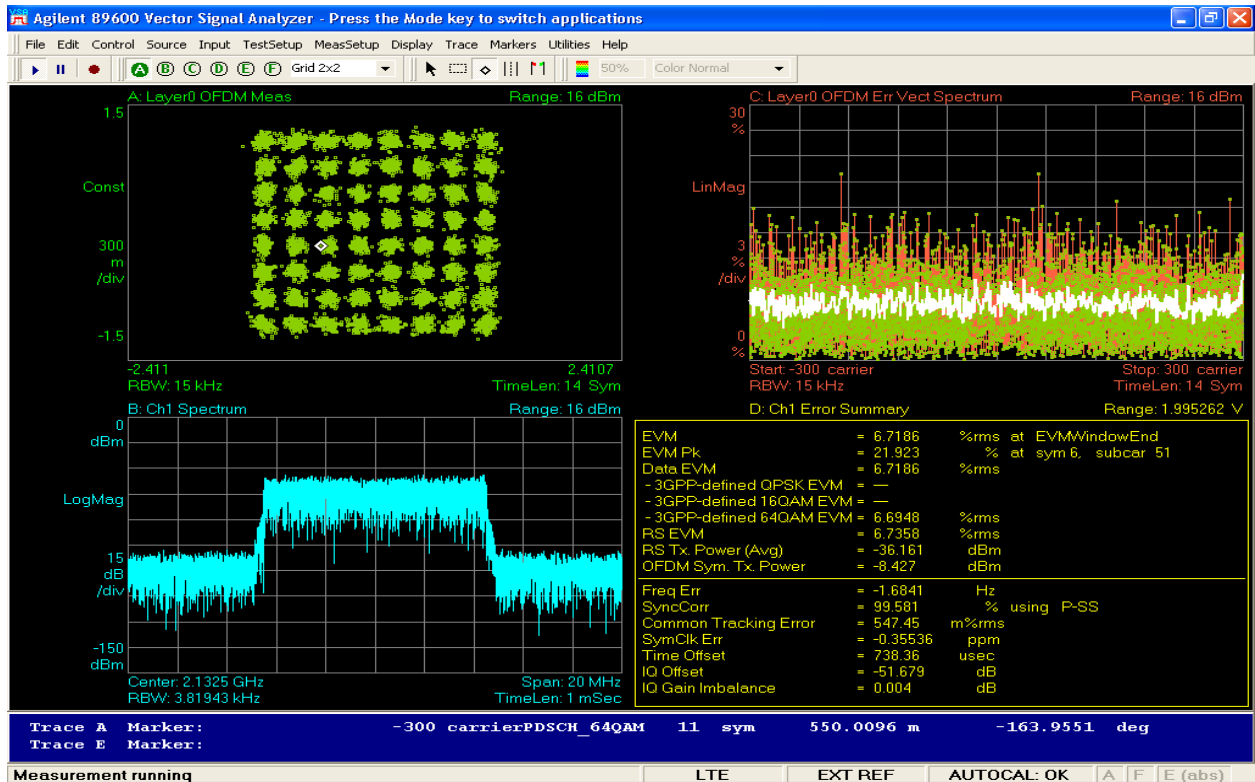

Figure 6-213 Stability 10MHz @ -20C

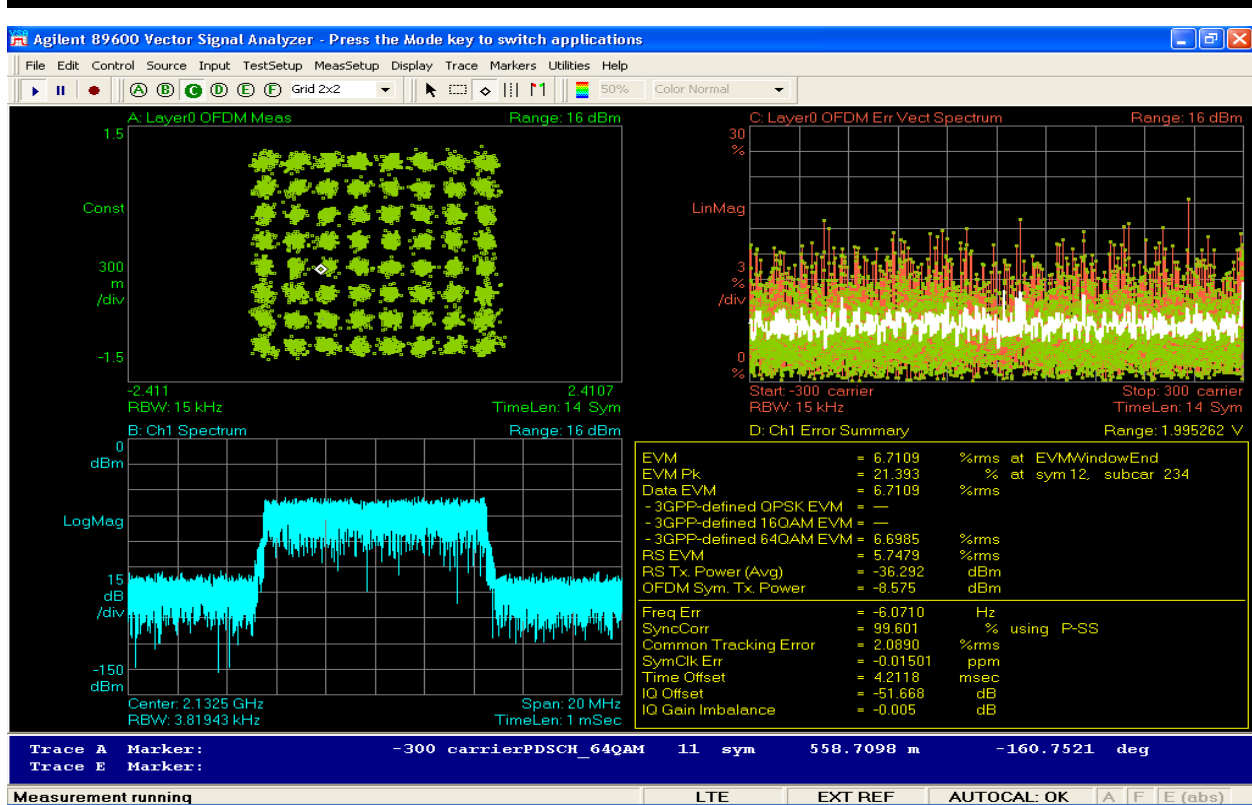

Figure 6-214 Stability 10MHz @ -10C

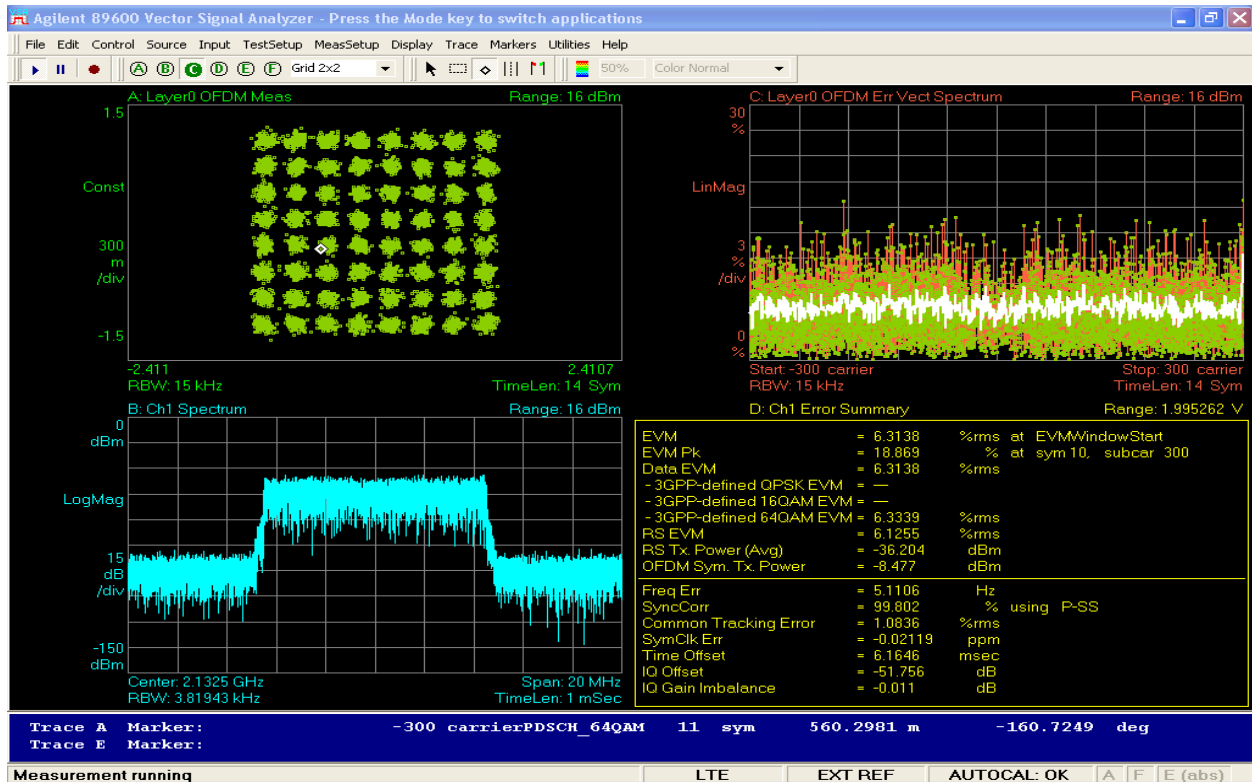

Figure 6-215 Stability 10MHz @ 0C

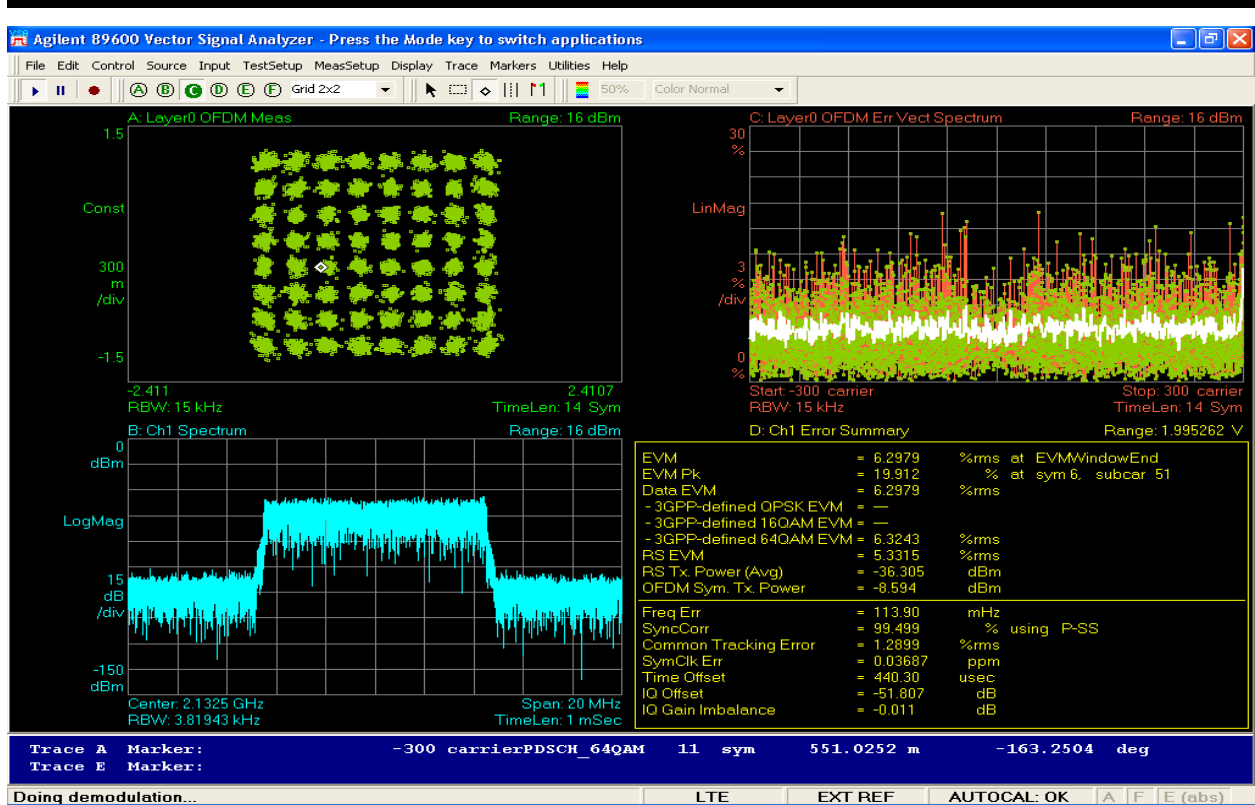

Figure 6-216 Stability 10MHz @ +10C

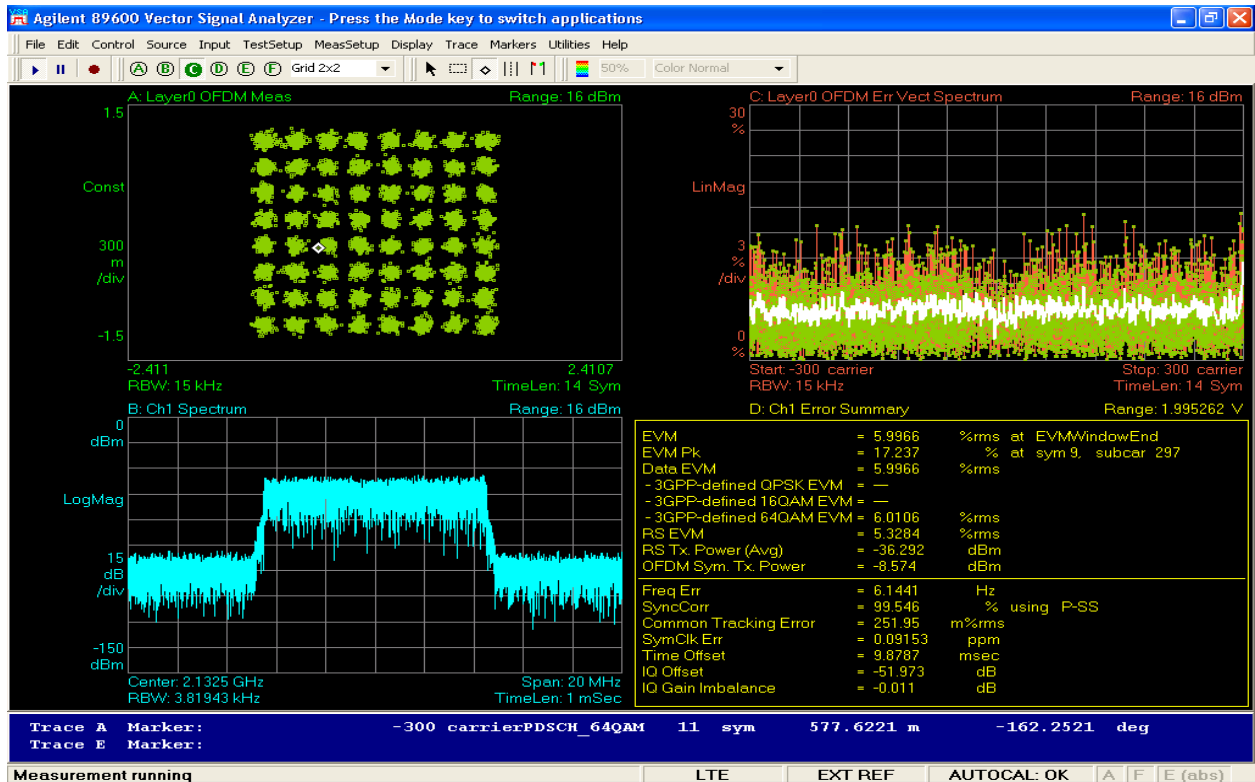

Figure 6-217 Stability 10MHz @ +20C

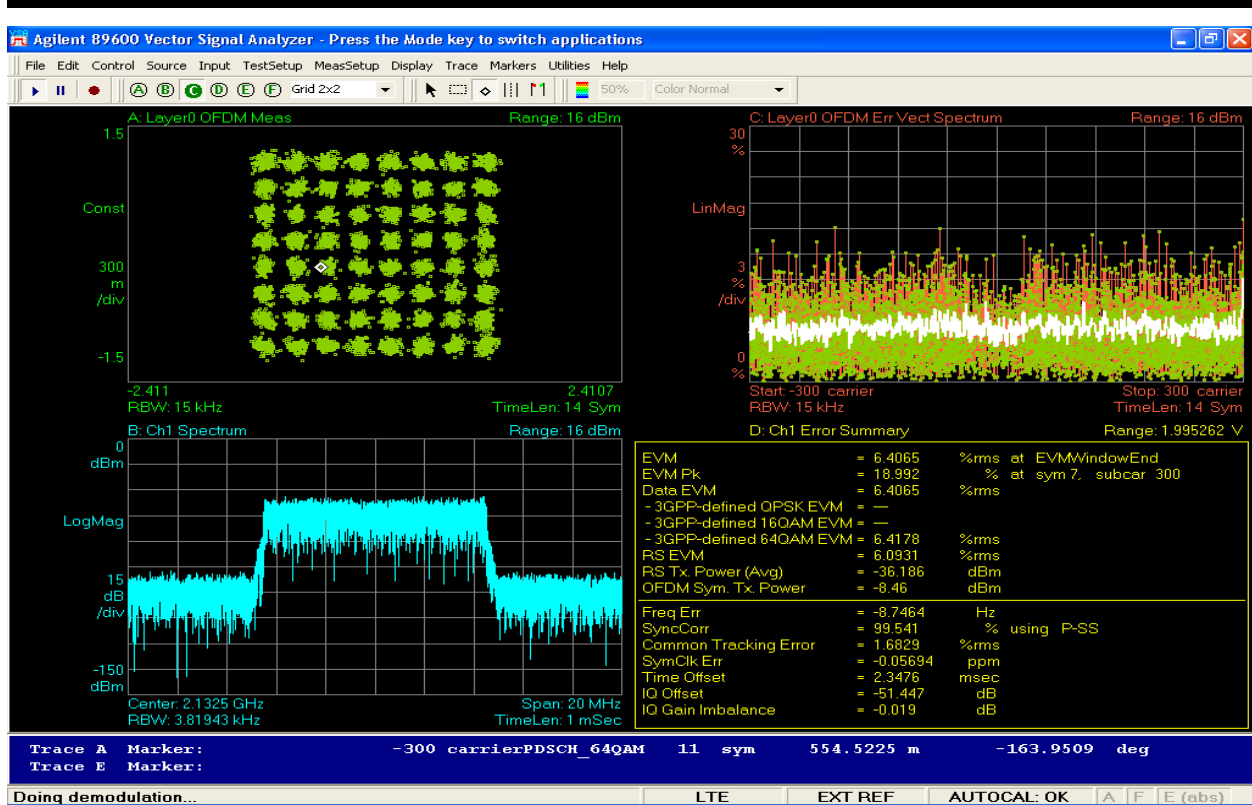

Figure 6-218 Stability 10MHz @ +30C

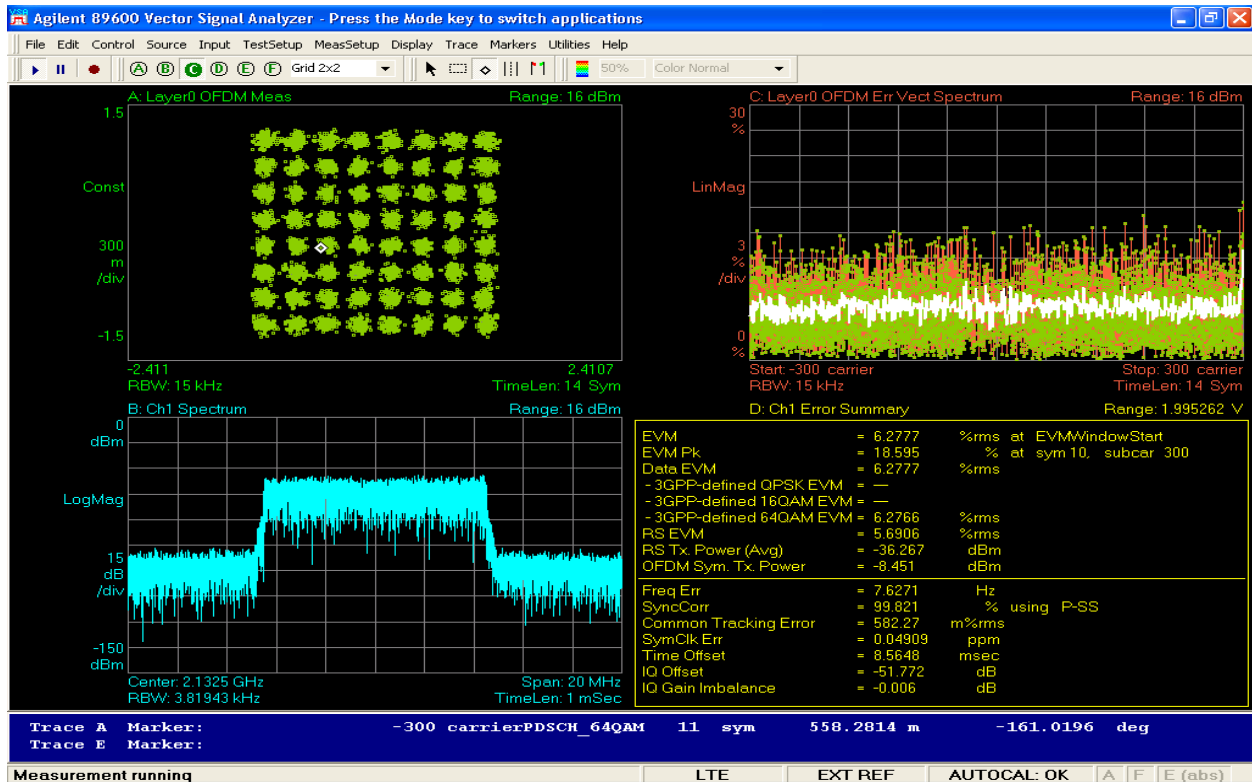

Figure 6-219 Stability 10MHz @ +40C

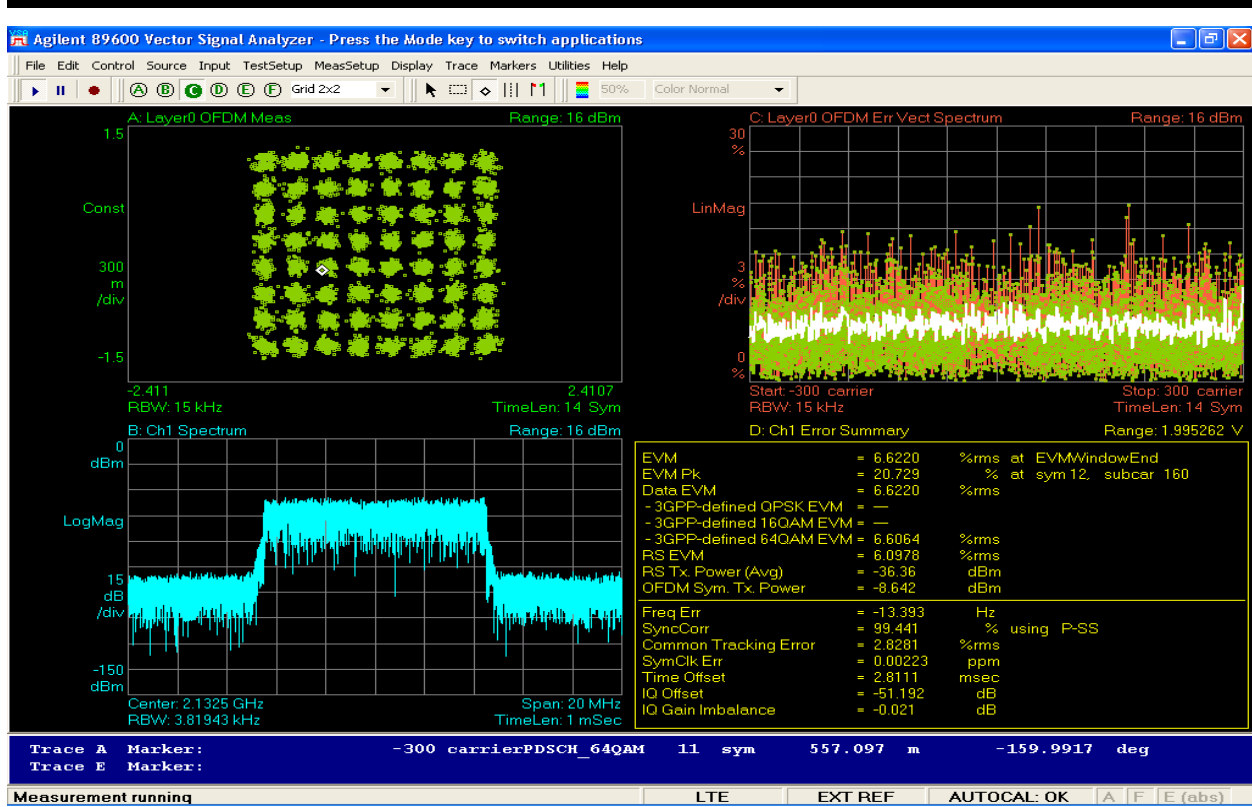

Figure 6-220 Stability 10MHz @ +50C



## **6.7 Submission Exhibits**

### **2.1033 Submission Exhibits**

- Schematics
- Bill of Materials
- Block Diagram
- User Manual
- Letter Head Technical Operation and Description
- Letter Head MPE Calculation
- Letter Head, Cover Letter, Confidentiality Request
- External Photo's
- Internal Photo's
- Tune up Procedure
- FCC Form 731
- Label Details (Format and location)
- Set-up Photo's
- Test Report