

Figure 6-260 Spurious Emission TX1 64QAM 742.5MHz – 5MHz (5GHz - 8GHz)

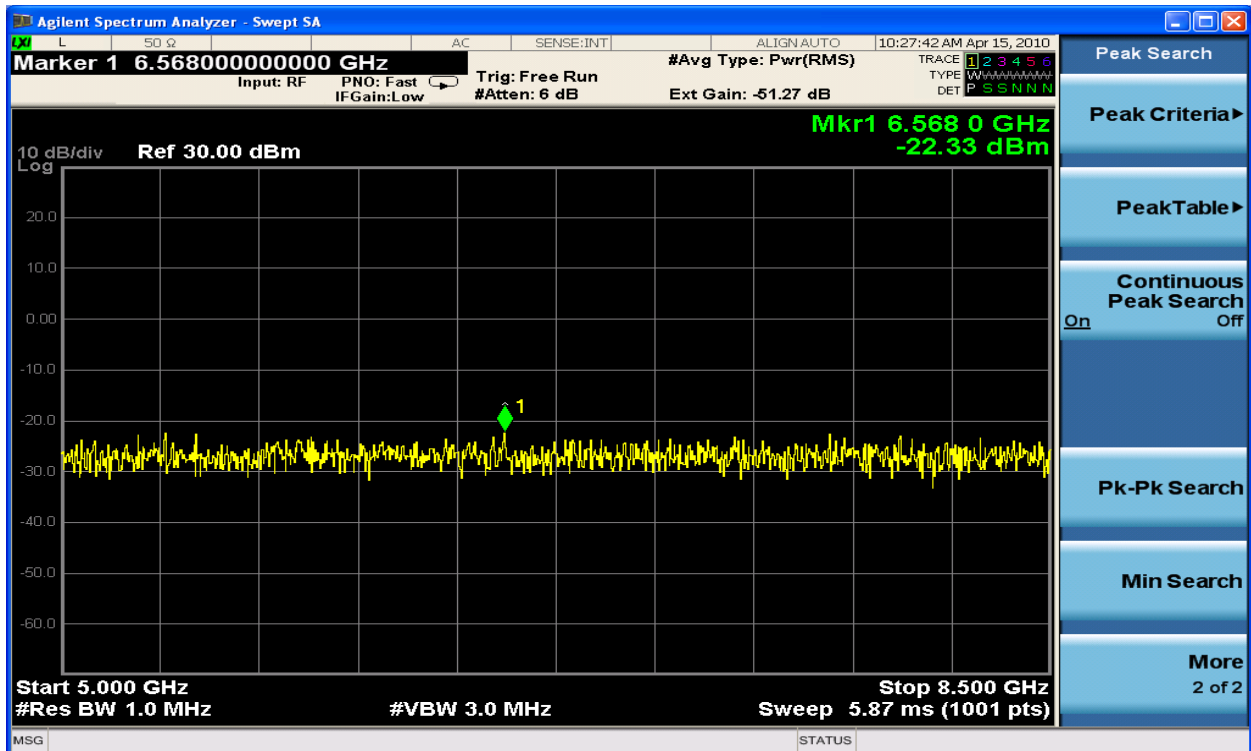

Figure 6-261 Spurious Emission TX2 64QAM 742.5MHz – 5MHz (5GHz - 8GHz)

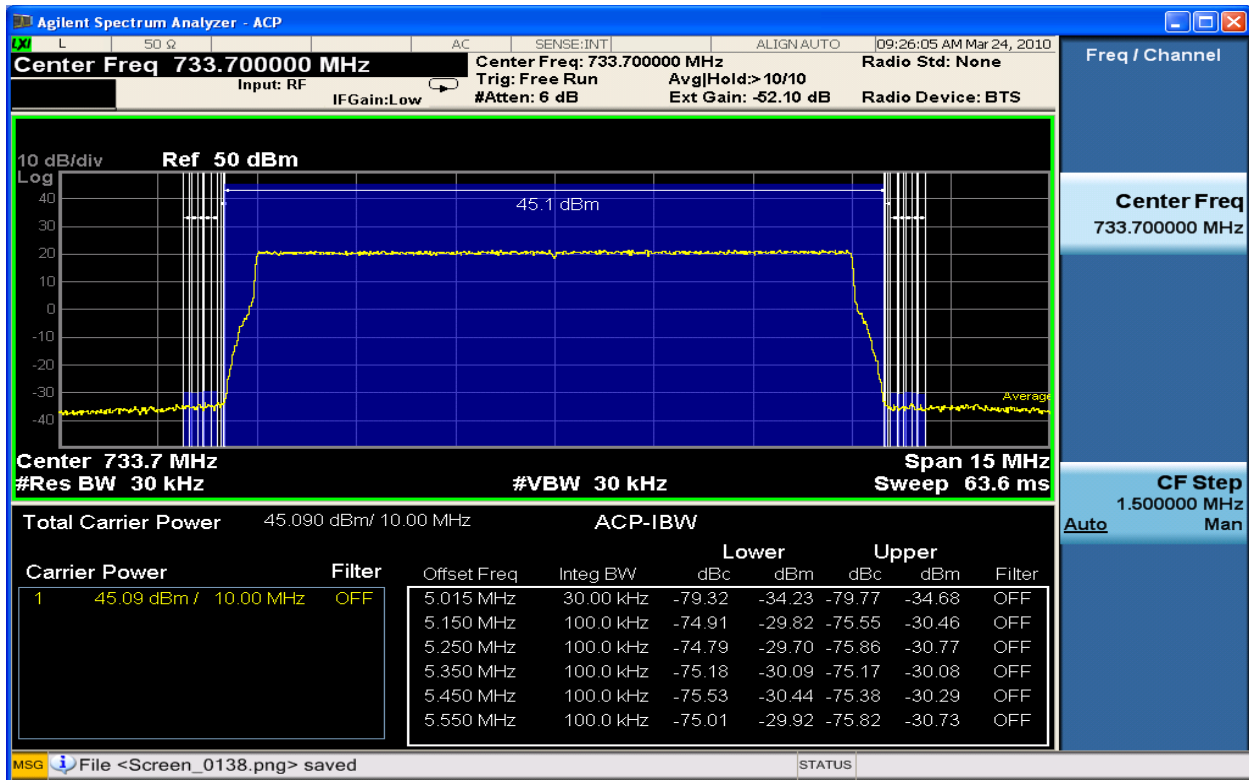

Figure 6-262 Spurious Emissions 733.7MHz TX1_QPSK 10MHz Band Edge (ACP 15kHz – 550KHz)

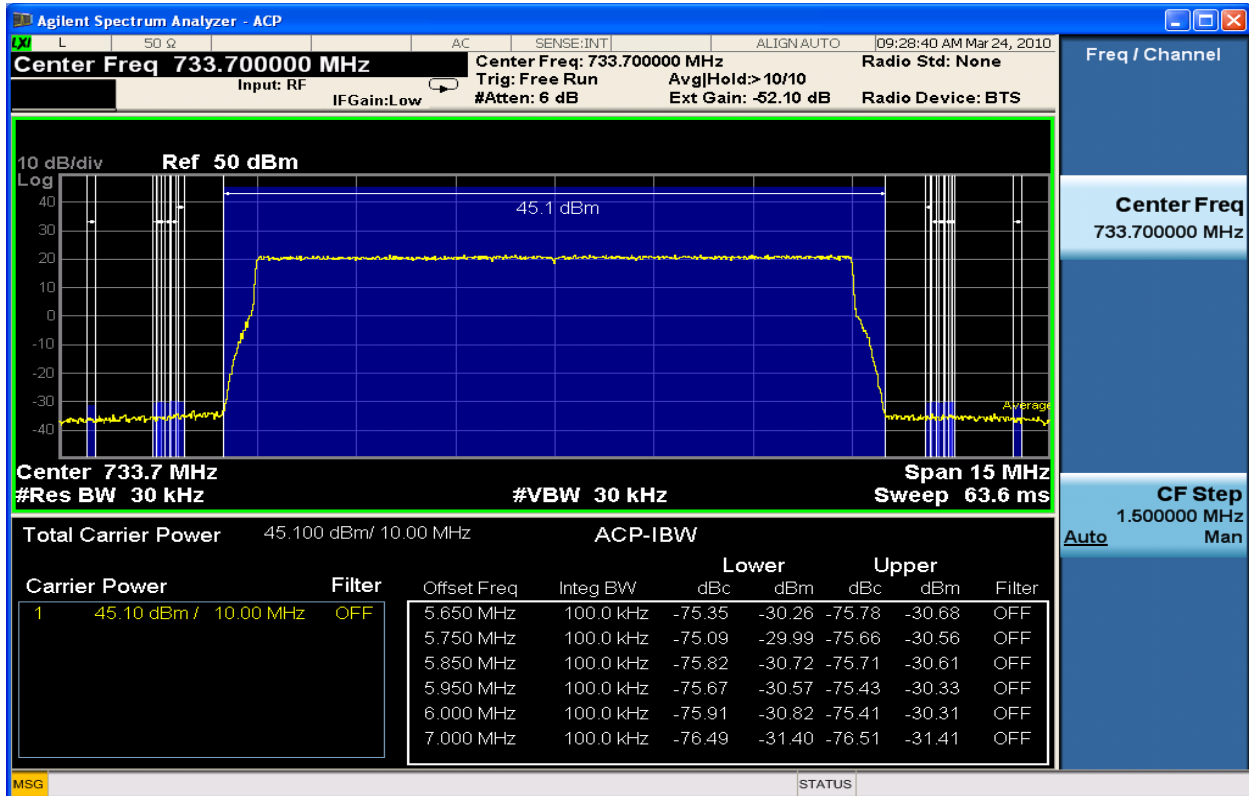

Figure 6-263 Spurious Emissions 733.7MHz TX1_QPSK 10MHz Band Edge (ACP 650kHz – 2MHz)

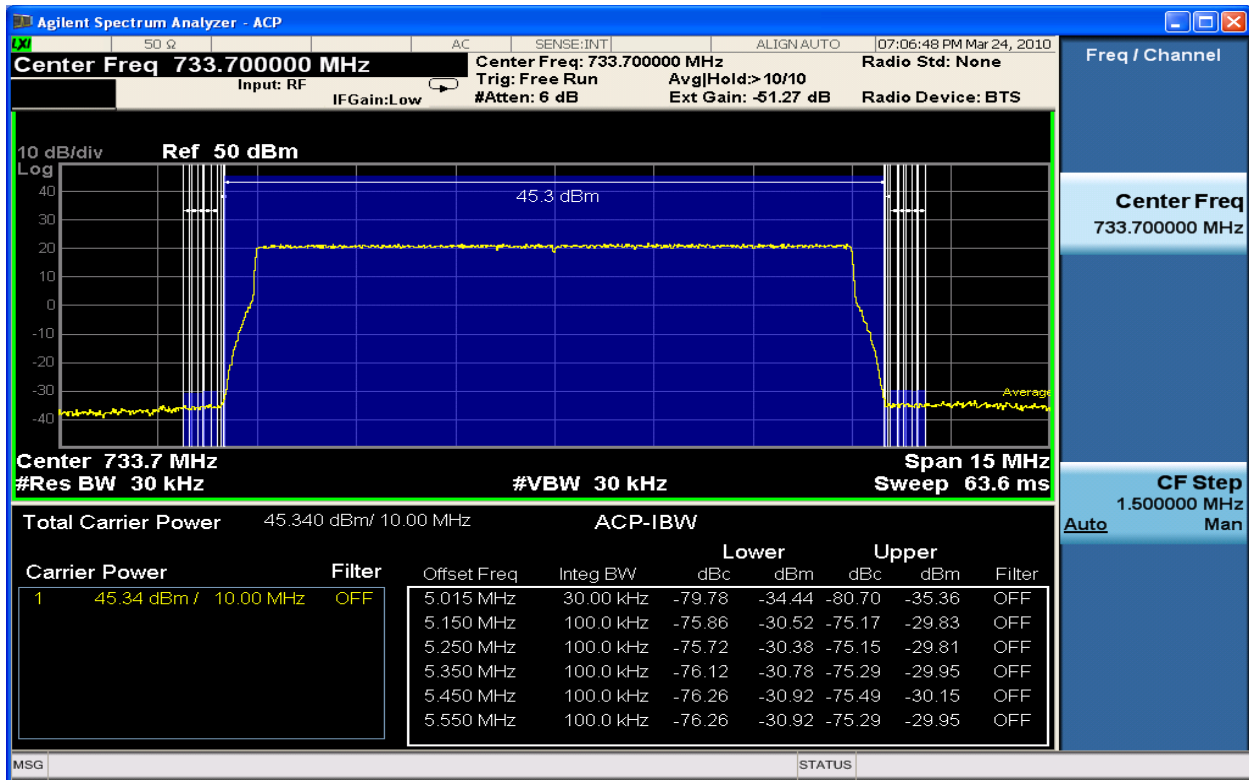

Figure 6-264 Spurious Emissions 733.7MHz TX2_QPSK 10MHz Band Edge (ACP 15kHz – 550KHz)

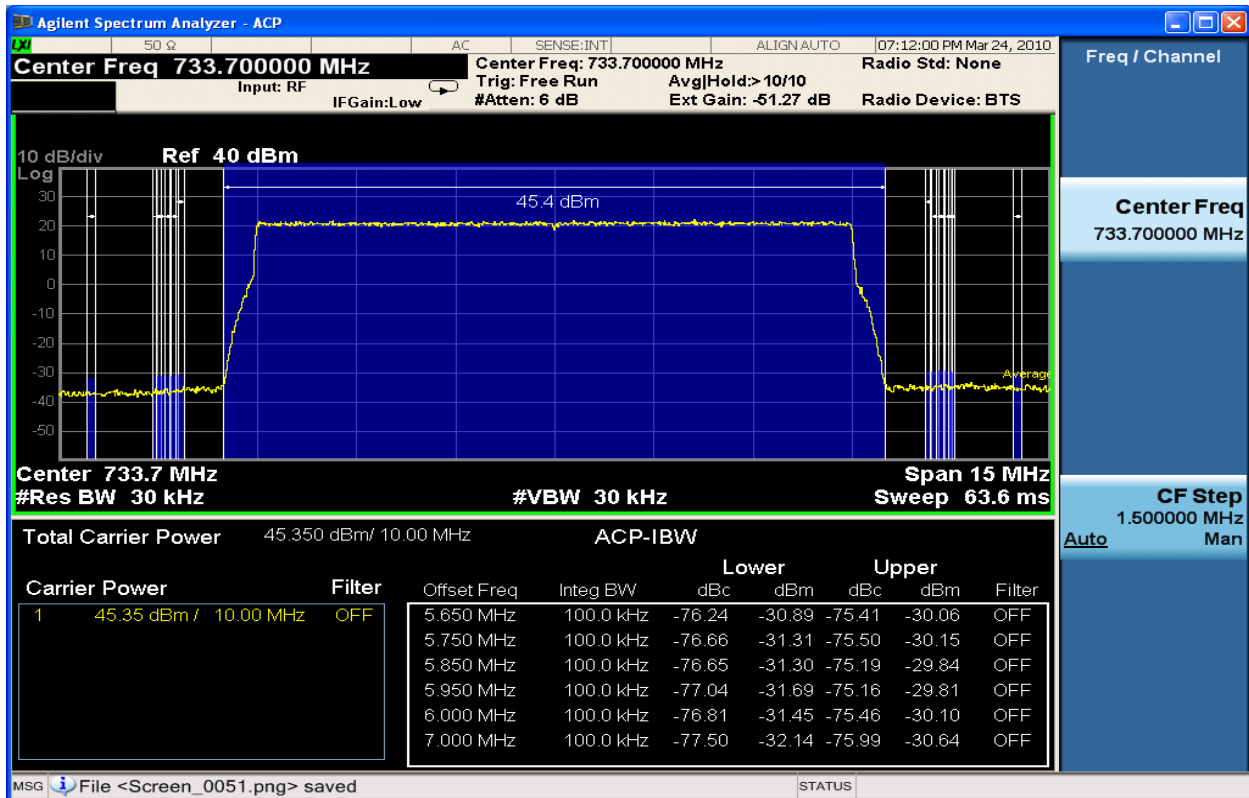

Figure 6-265 Spurious Emissions 733.7MHz TX2_QPSK 10MHz Band Edge (ACP 650kHz – 2MHz)

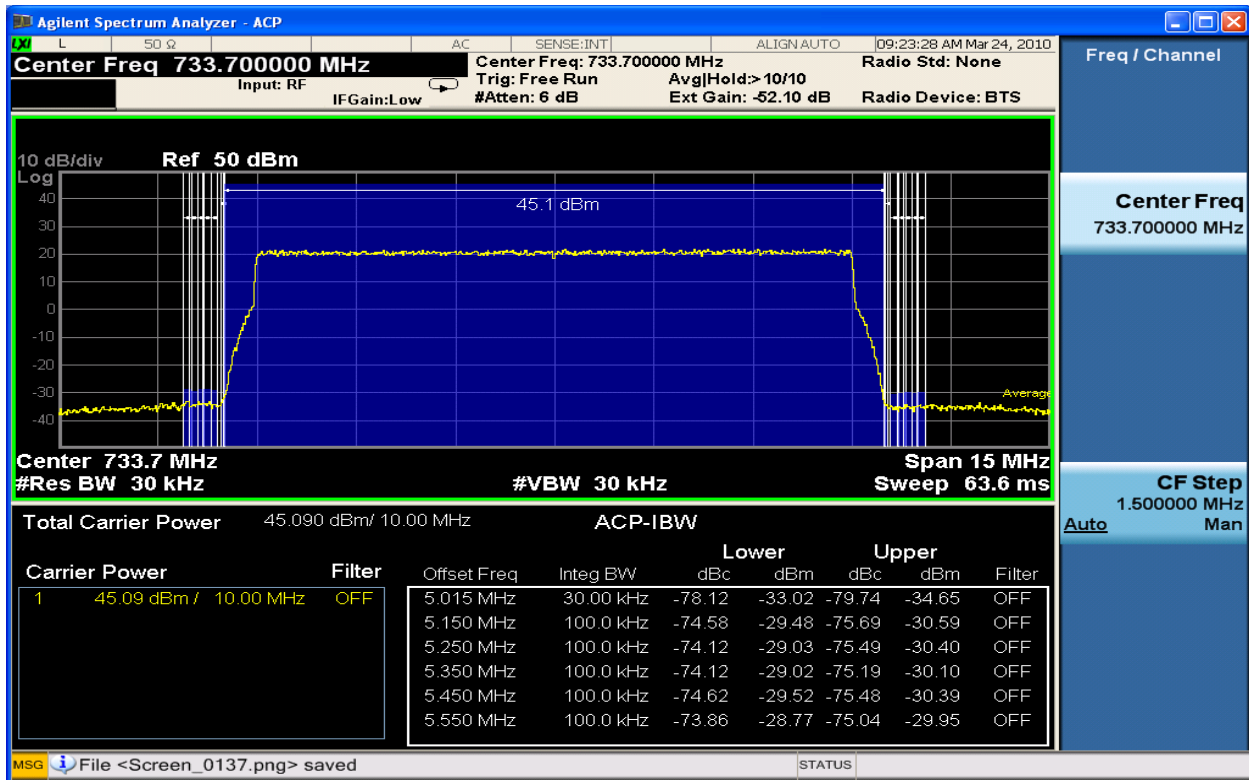

Figure 6-266 Spurious Emissions 733.7MHz TX1_16QAM 10MHz Band Edge (ACP 15kHz – 550KHz)

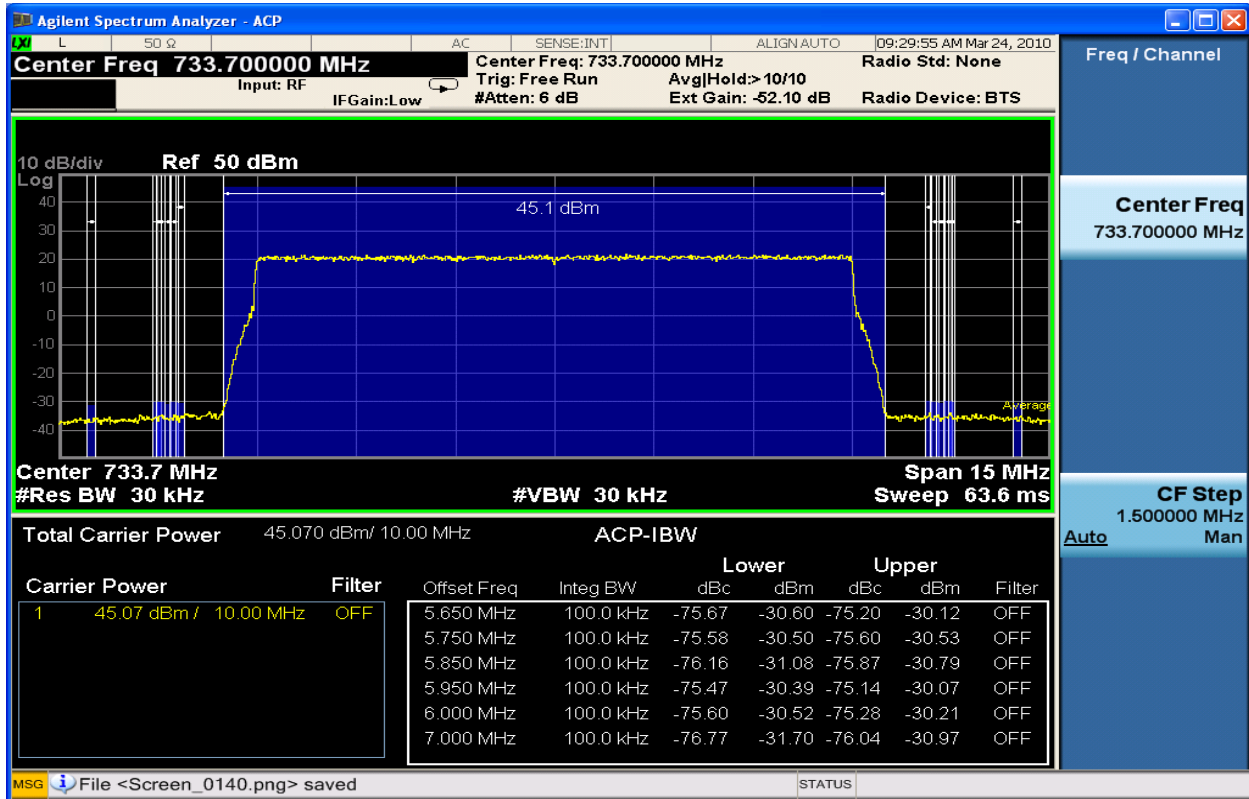

Figure 6-267 Spurious Emissions 733.7MHz TX1_16QAM 10MHz Band Edge (ACP 650kHz – 2MHz)

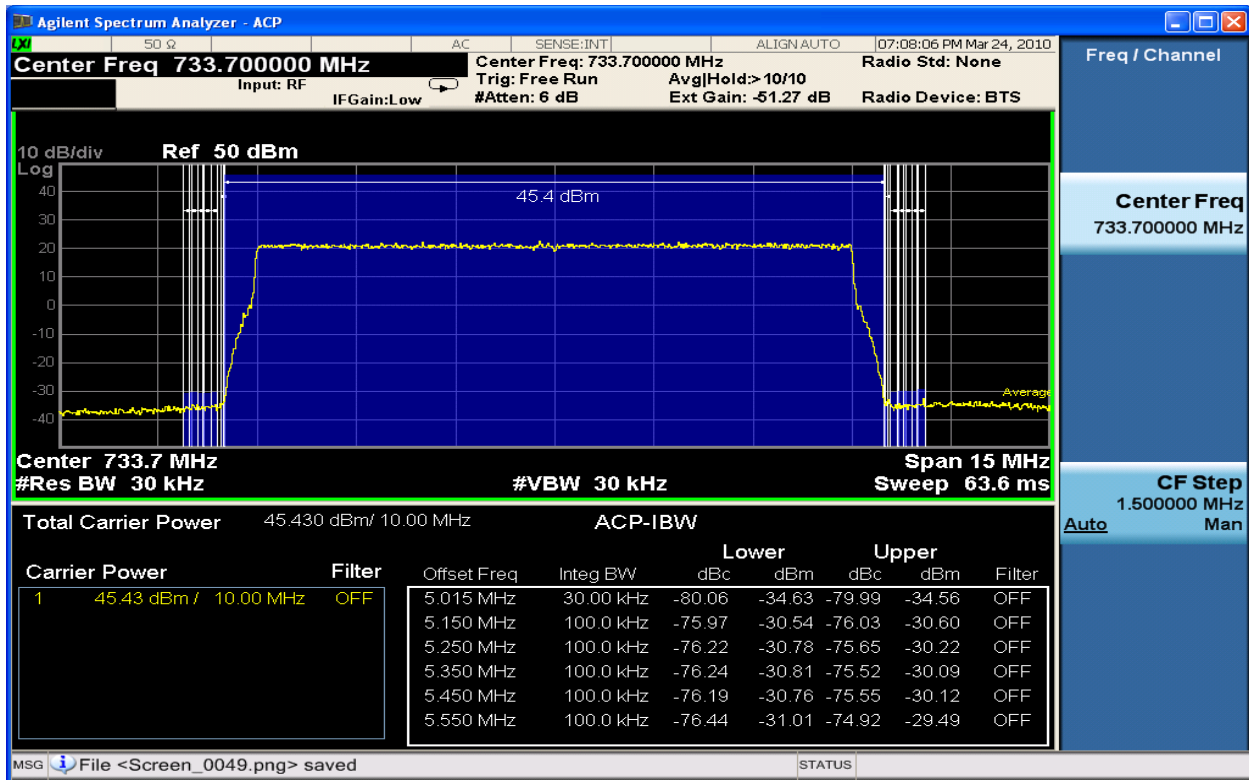

Figure 6-268 Spurious Emissions 733.7MHz TX2_16QAM 10MHz Band Edge (ACP 15kHz – 550KHz)

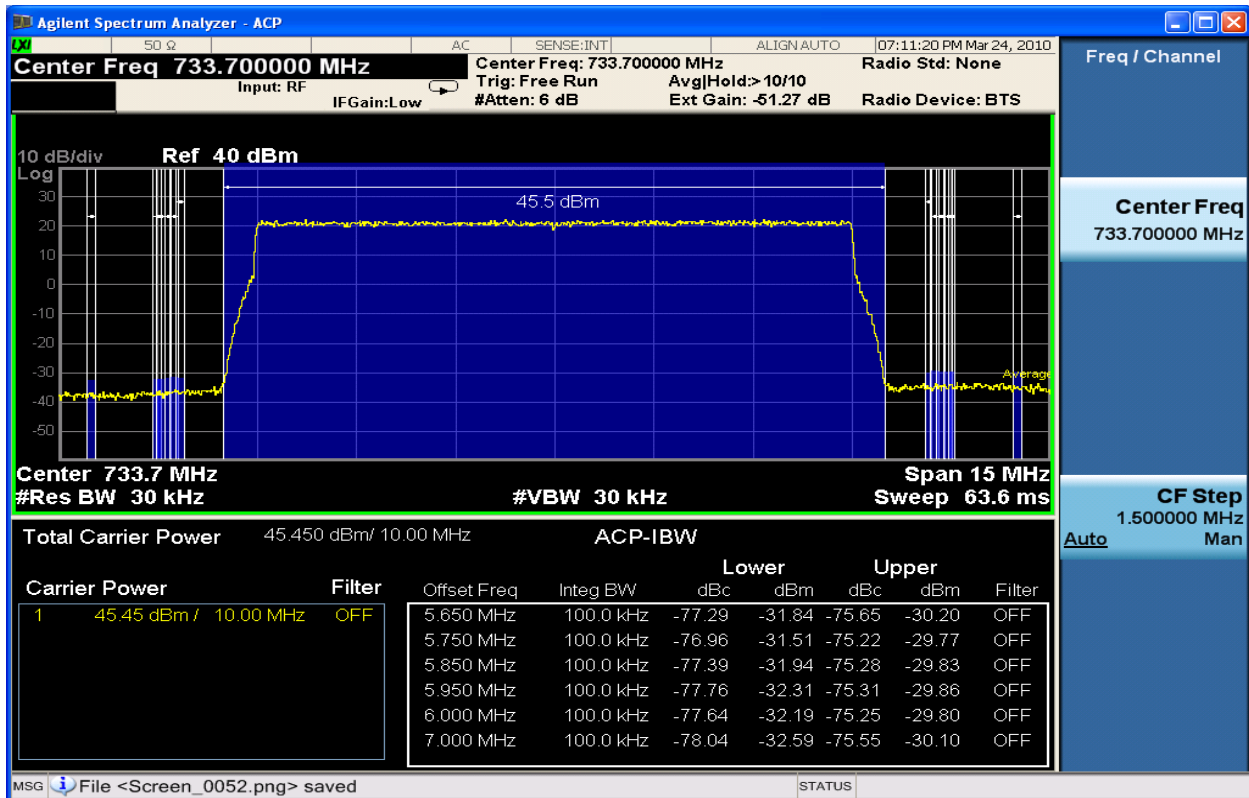

Figure 6-269 Spurious Emissions 733.7MHz TX2_16QAM 10MHz Band Edge (ACP 650kHz – 2MHz)

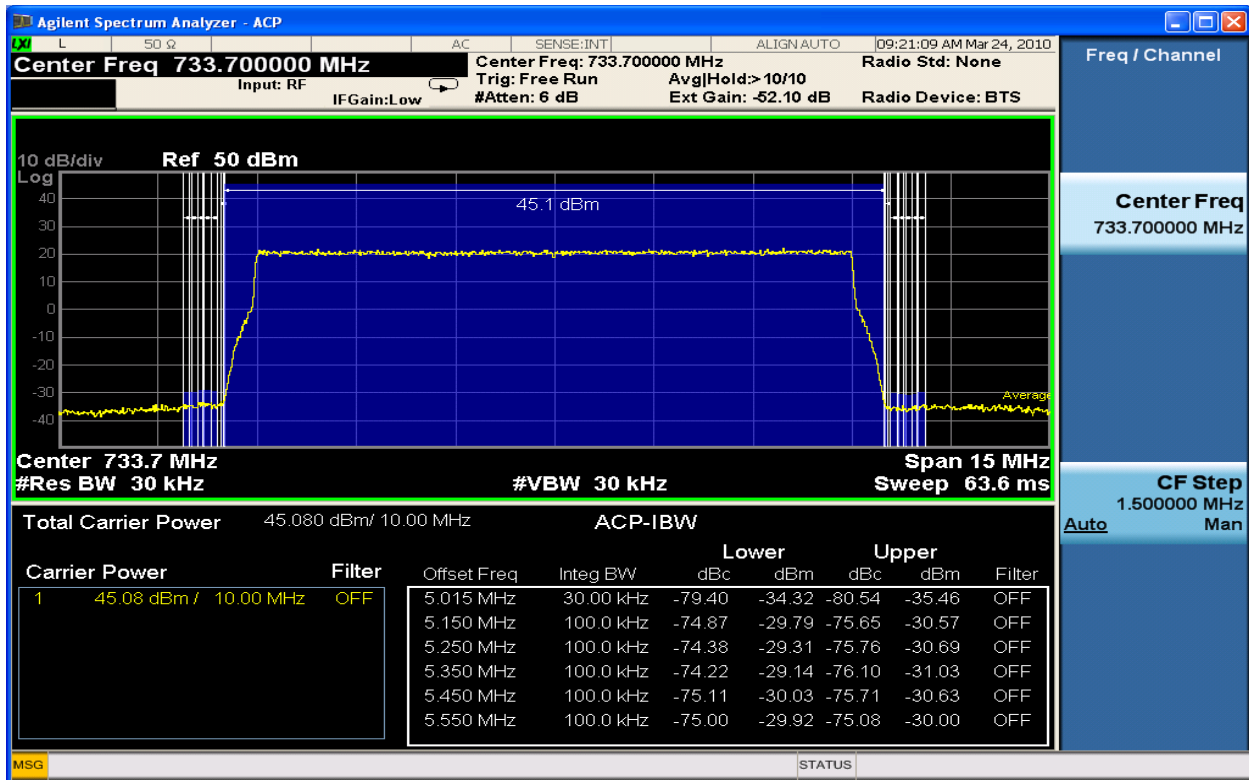

Figure 6-270 Spurious Emissions 733.7MHz TX1_64QAM 10MHz Band Edge (ACP 15kHz – 550KHz)

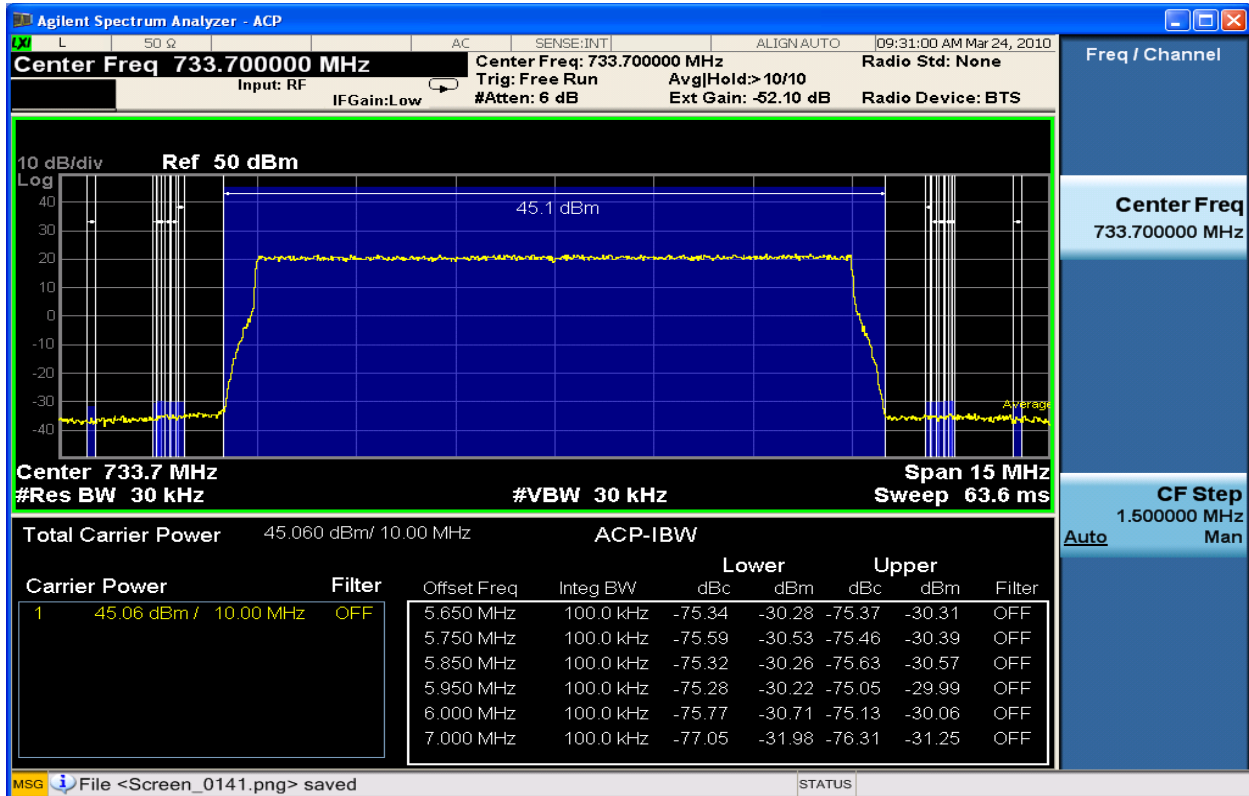

Figure 6-271 Spurious Emissions 733.7MHz TX1_64QAM 10MHz Band Edge (ACP 650kHz – 2MHz)

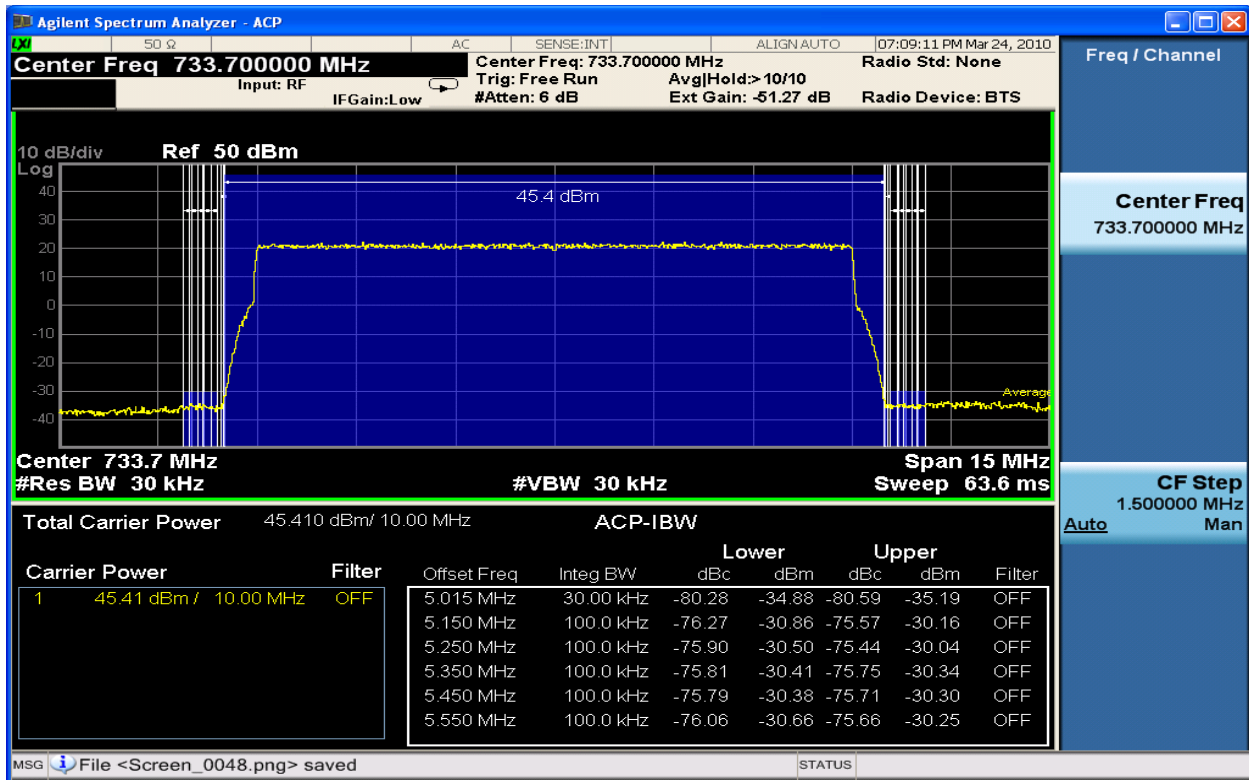

Figure 6-272 Spurious Emissions 733.7MHz TX2_64QAM 10MHz Band Edge (ACP 15kHz – 550kHz)

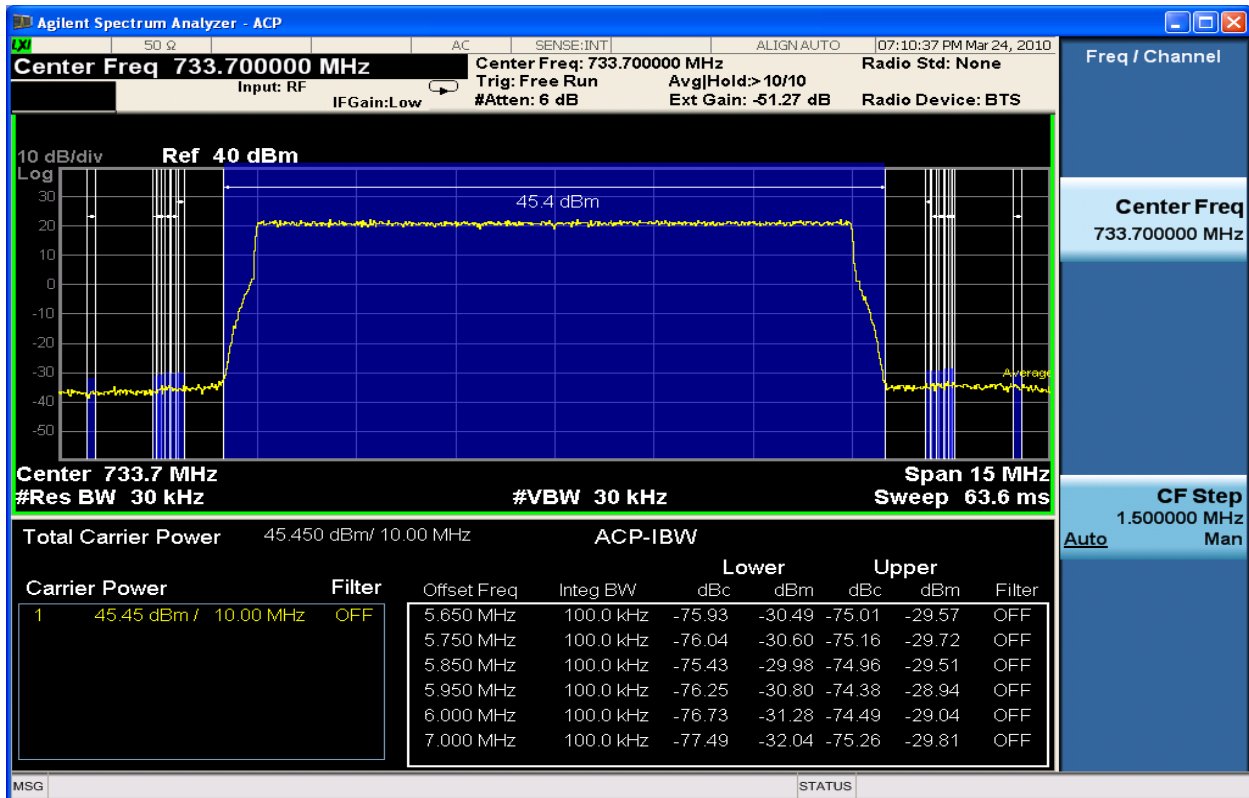

Figure 6-273 Spurious Emissions 733.7MHz TX2_64QAM 10MHz Band Edge (ACP 650kHz – 2MHz)

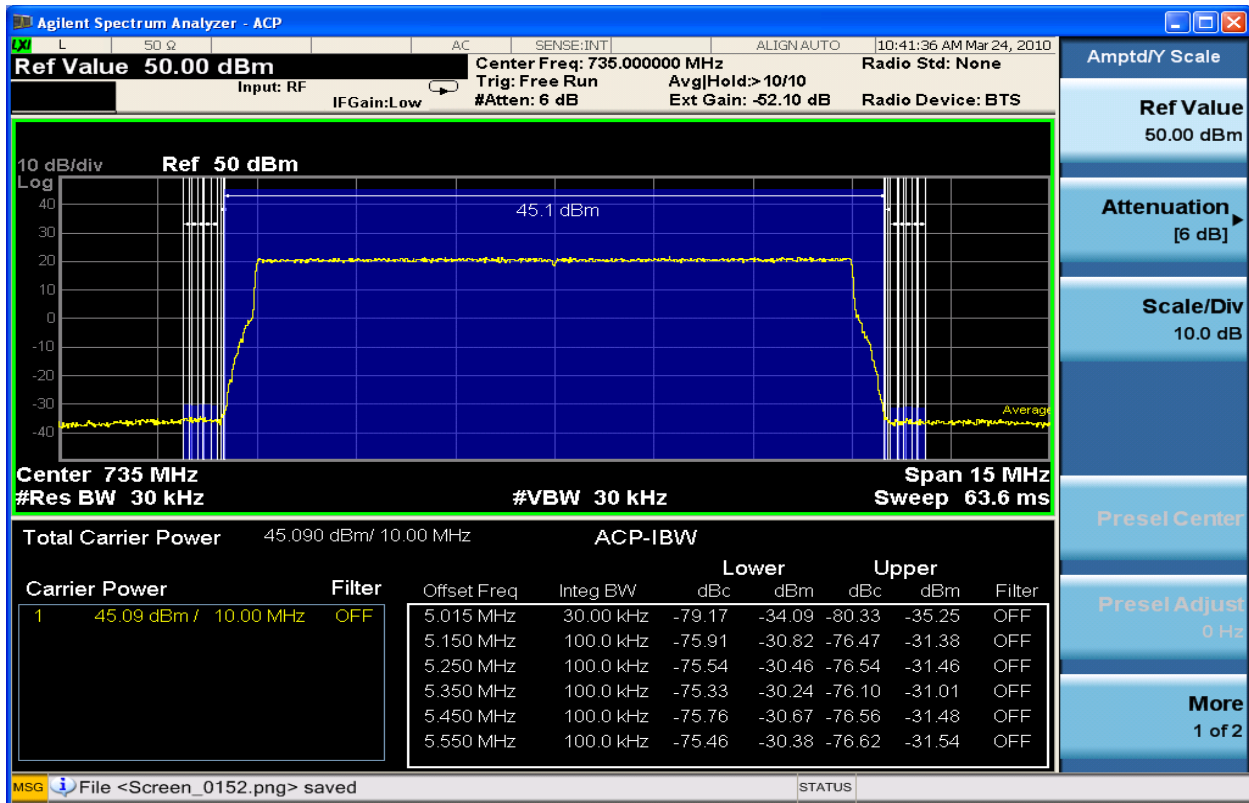

Figure 6-274 Spurious Emissions 735MHz TX1_QPSK 10MHz Band Edge (ACP 15kHz – 550KHz)

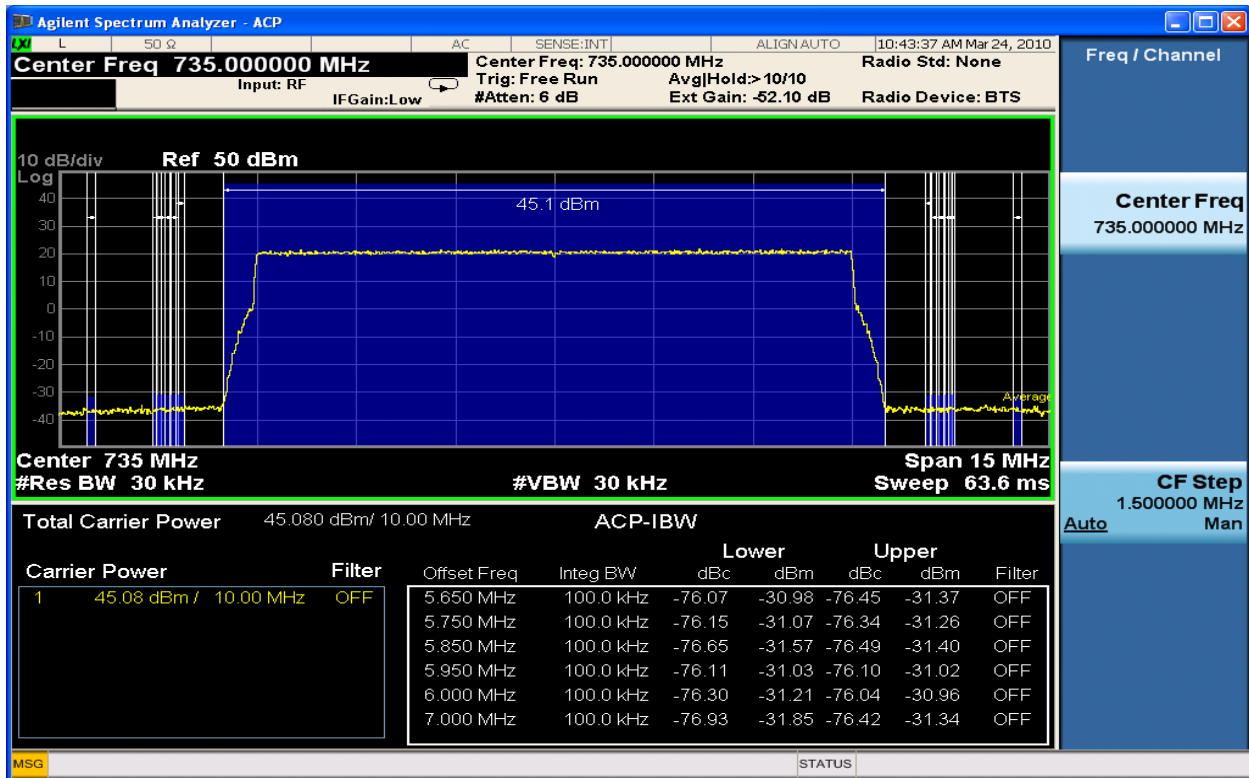

Figure 6-275 Spurious Emissions 735MHz TX1_QPSK 10MHz Band Edge (ACP 650kHz – 2MHz)

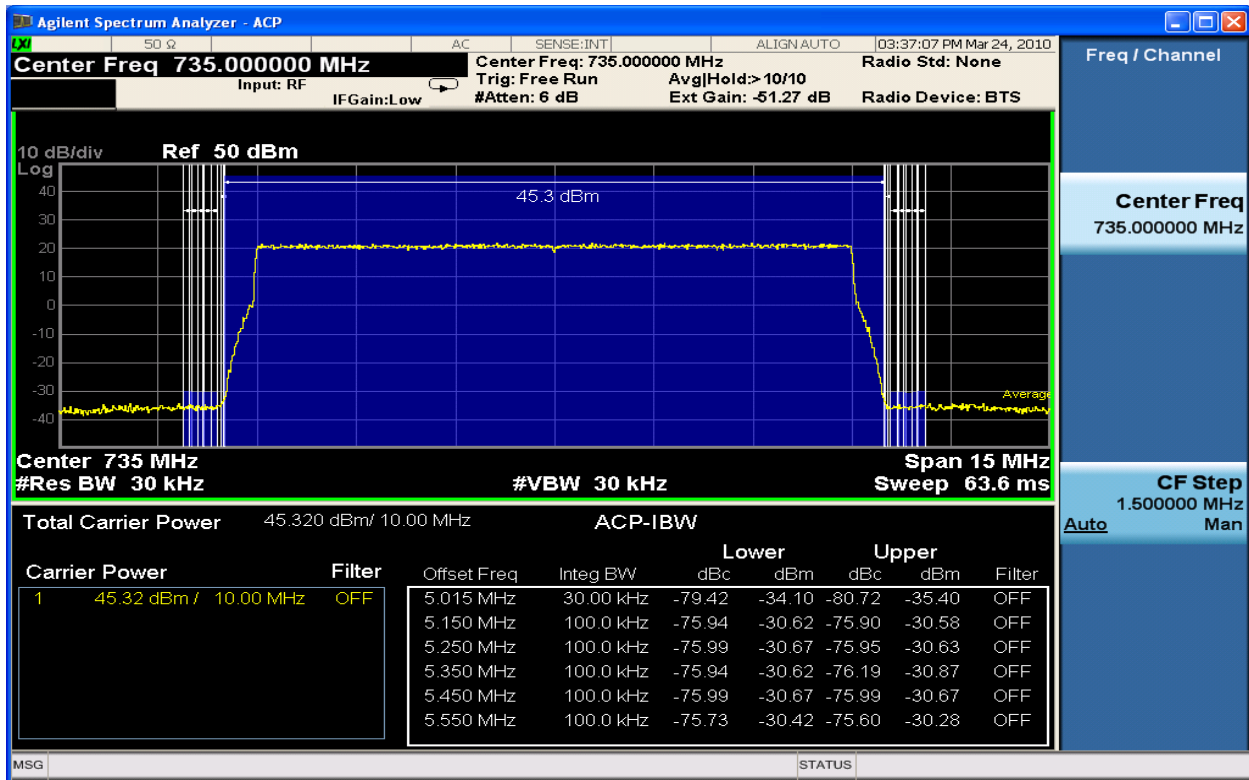

Figure 6-276 Spurious Emissions 735MHz TX2_QPSK 10MHz Band Edge (ACP 15kHz – 550KHz)

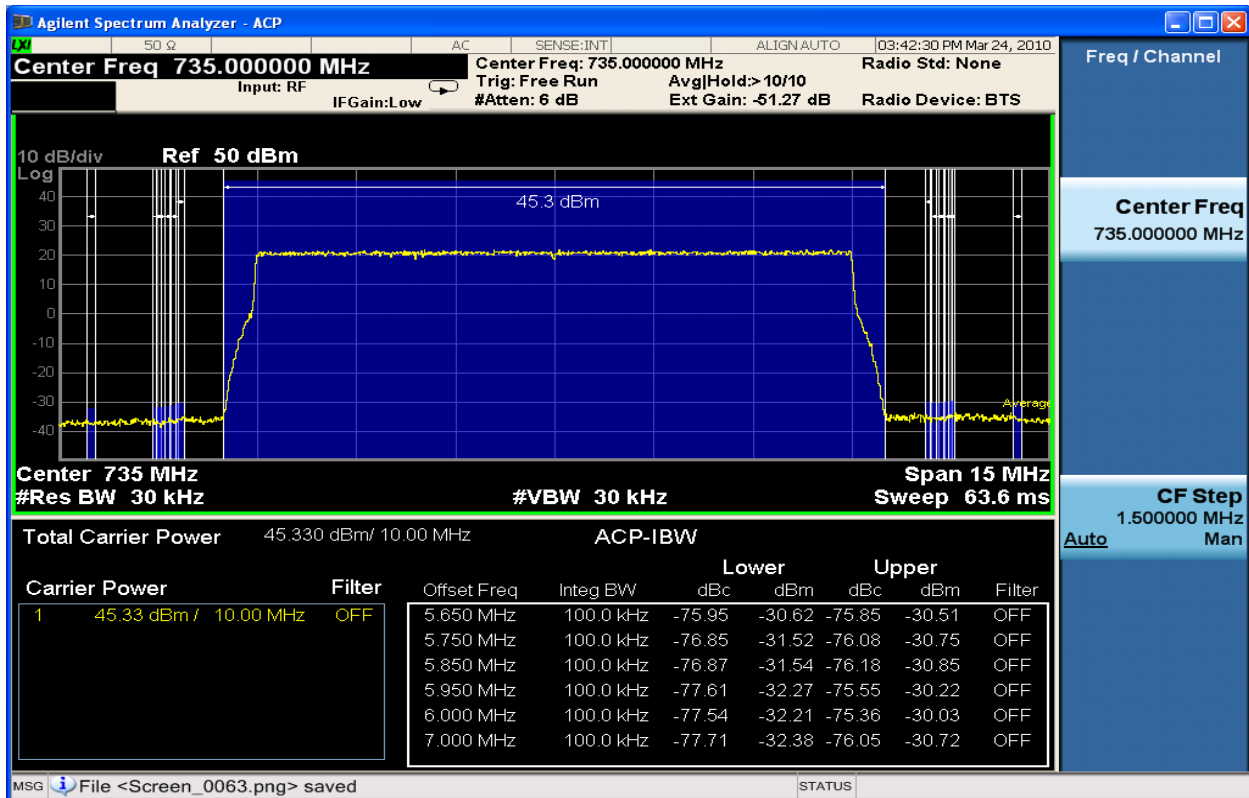

Figure 6-277 Spurious Emissions 735MHz TX2_QPSK 10MHz Band Edge (ACP 650kHz – 2MHz)

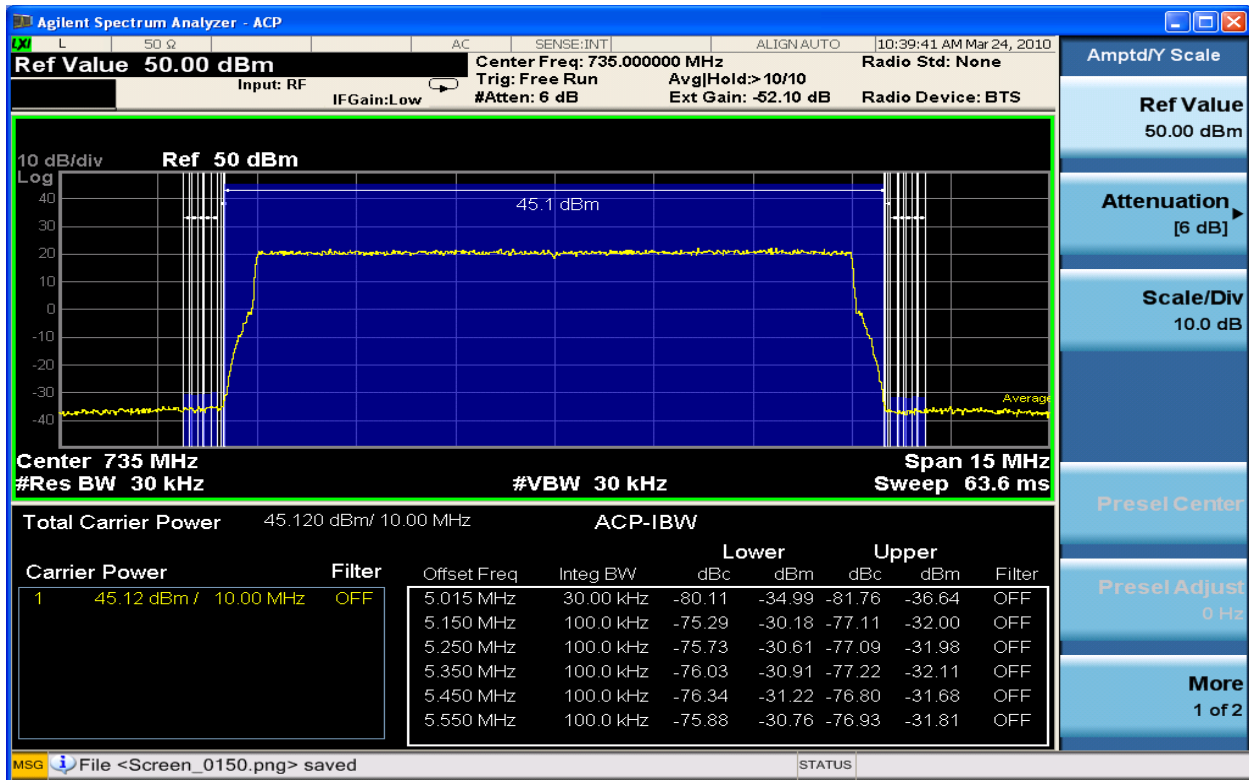

Figure 6-278 Spurious Emissions 735MHz TX1_16QAM 10MHz Band Edge (ACP 15kHz – 550KHz)

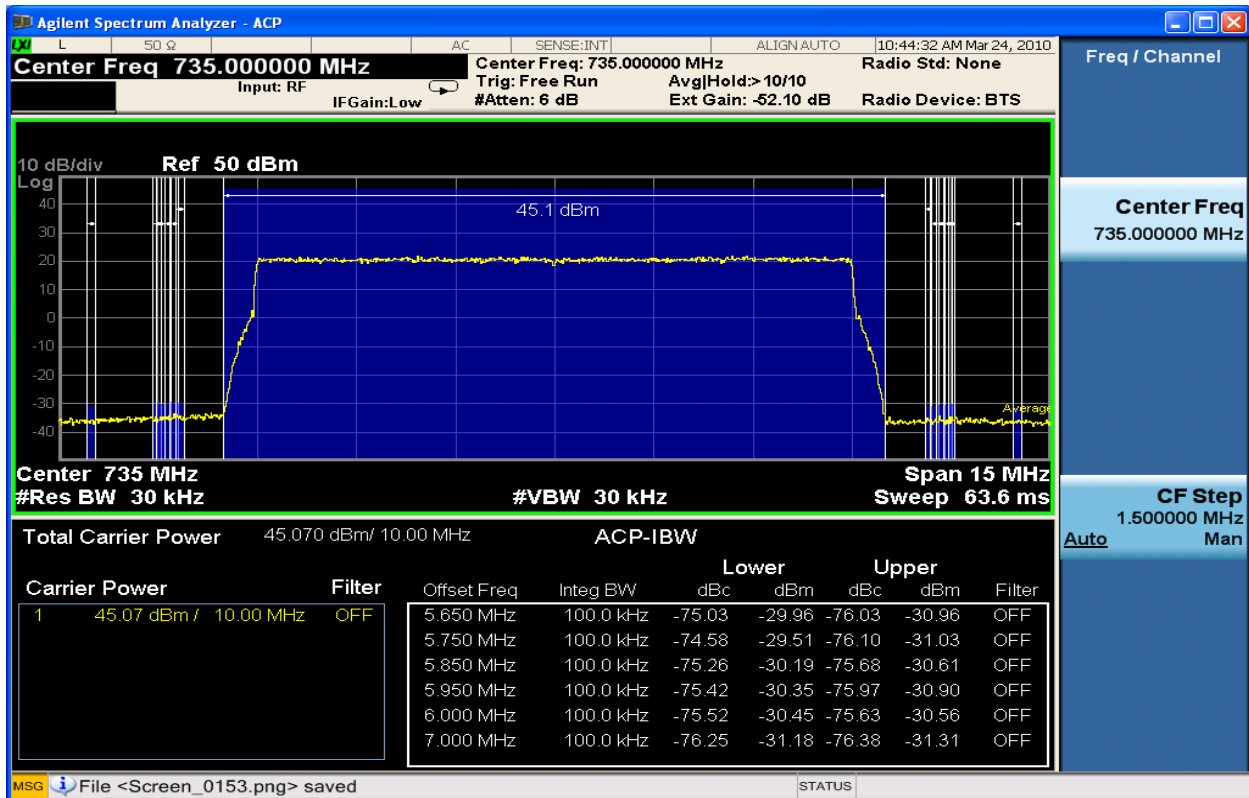

Figure 6-279 Spurious Emissions 735MHz TX1_16QAM 10MHz Band Edge (ACP 650kHz – 2MHz)

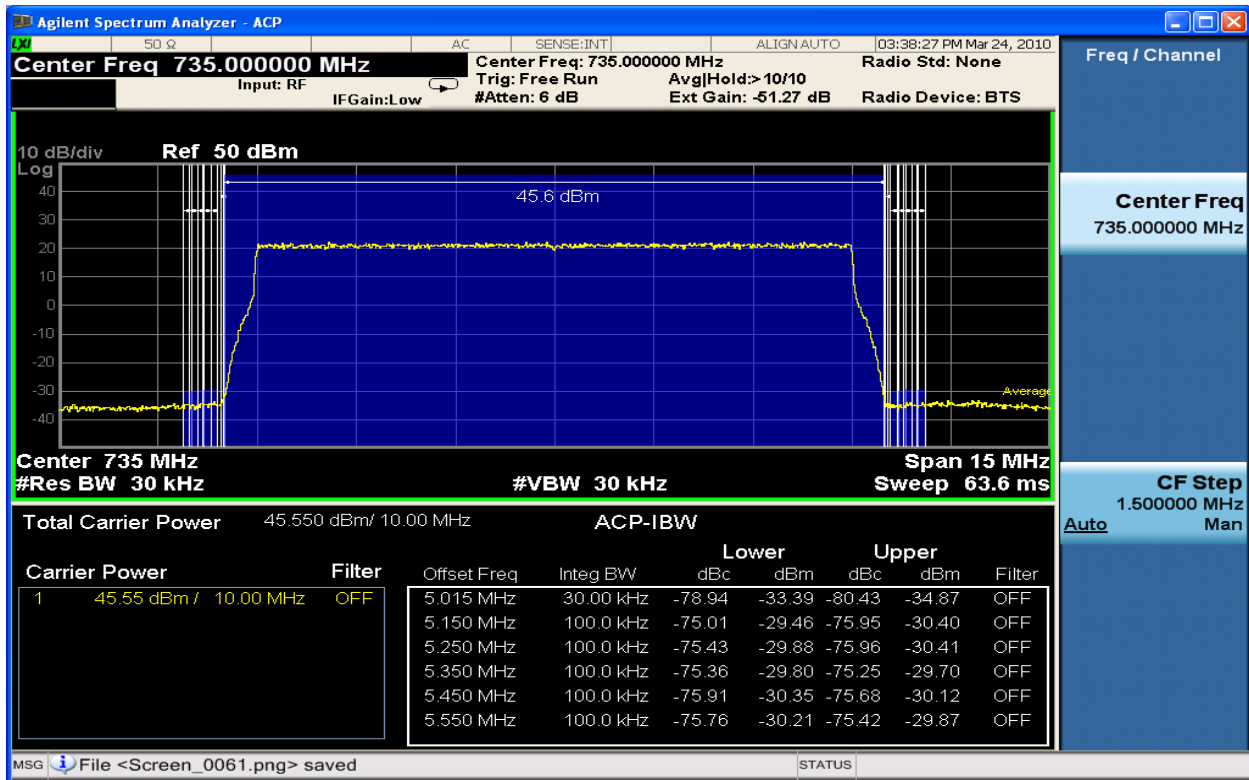

Figure 6-280 Spurious Emissions 735MHz TX2_16QAM 10MHz Band Edge (ACP 15kHz – 550KHz)

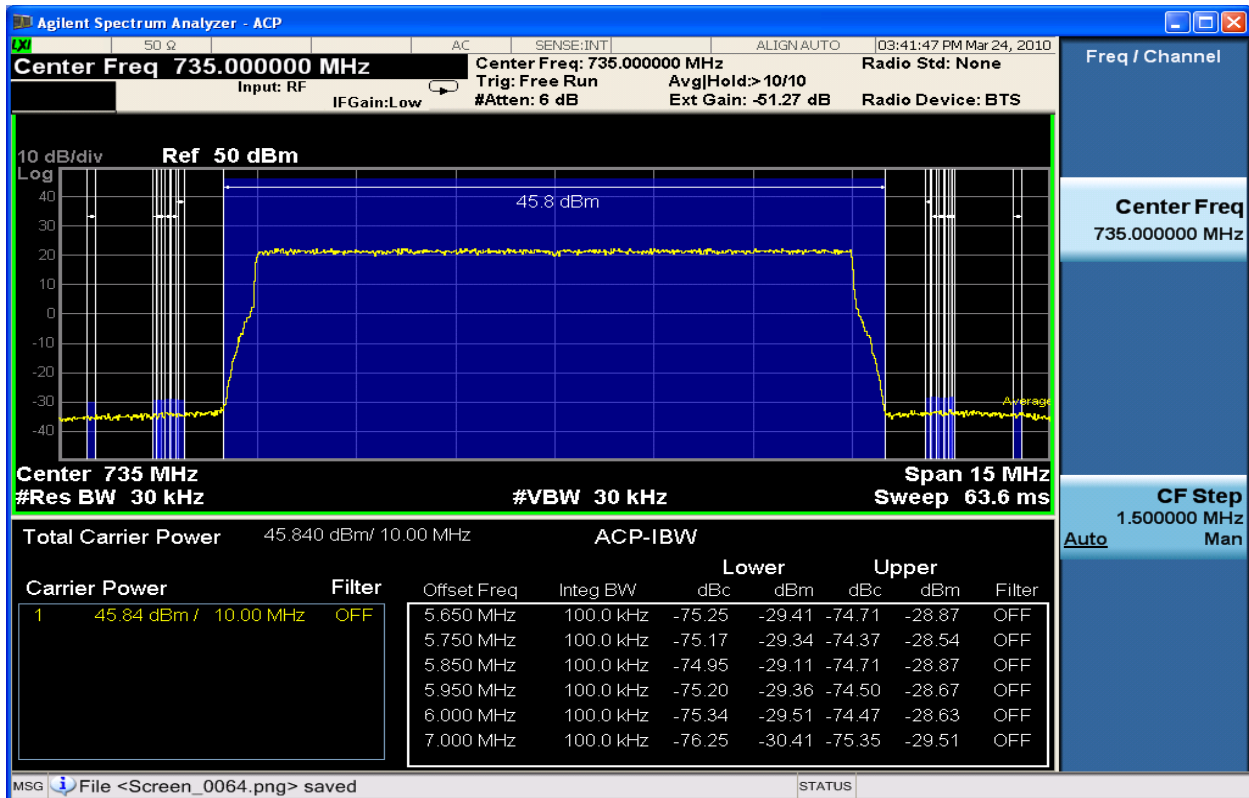

Figure 6-281 Spurious Emissions 735MHz TX2_16QAM 10MHz Band Edge (ACP 650kHz – 2MHz)

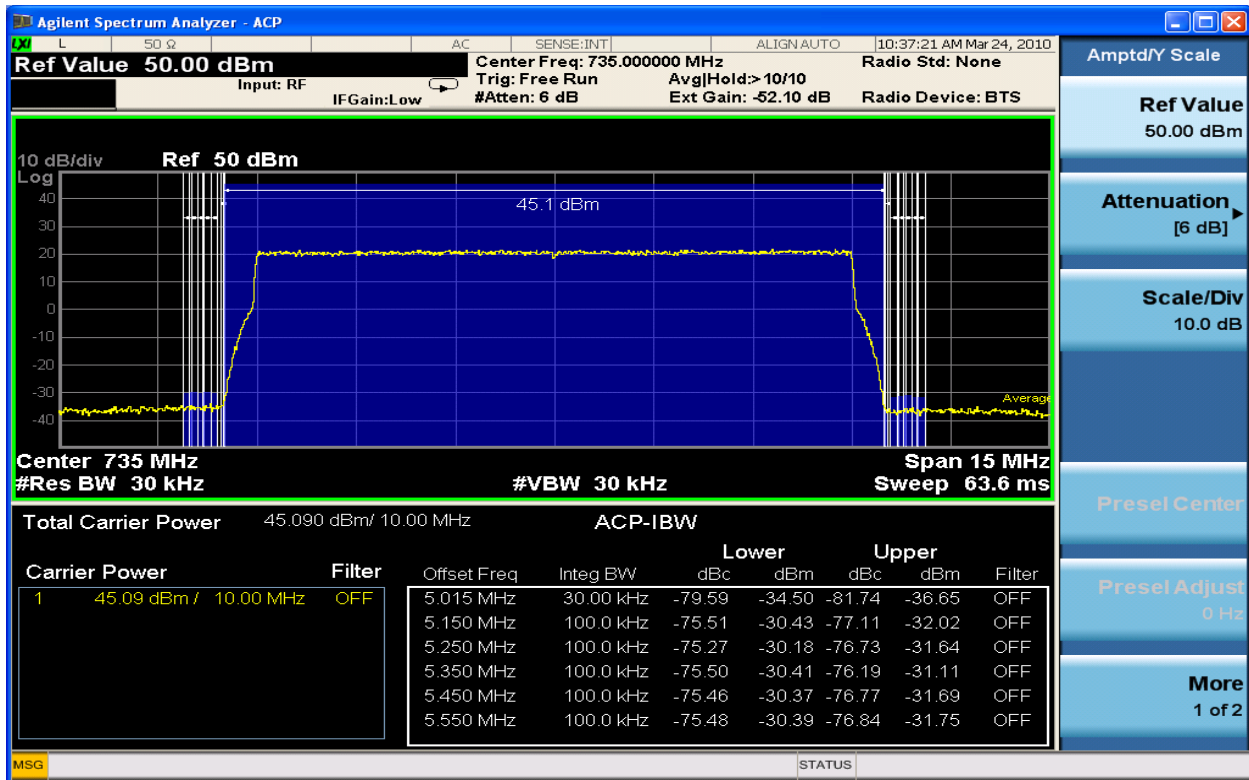

Figure 6-282 Spurious Emissions 735MHz TX1_64QAM 10MHz Band Edge (ACP 15kHz – 550KHz)

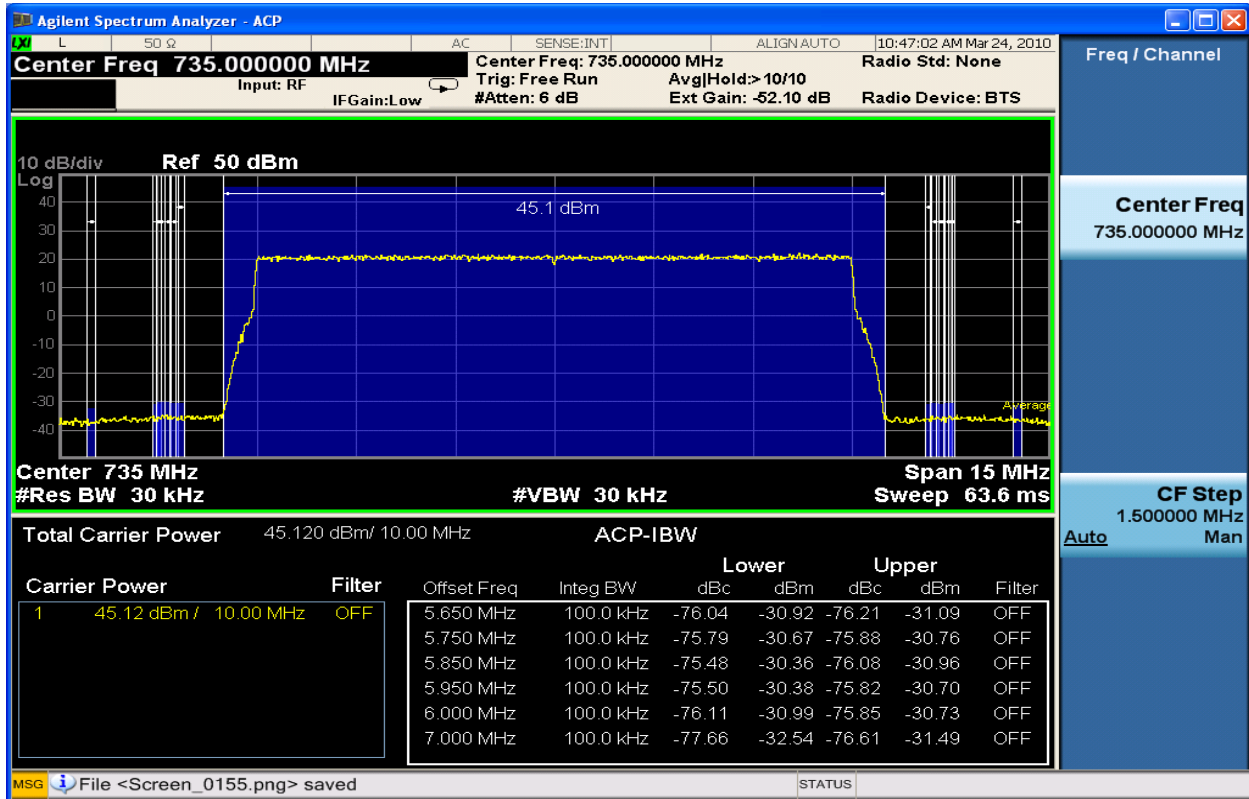

Figure 6-283 Spurious Emissions 735MHz TX1_64QAM 10MHz Band Edge (ACP 650kHz – 2MHz)

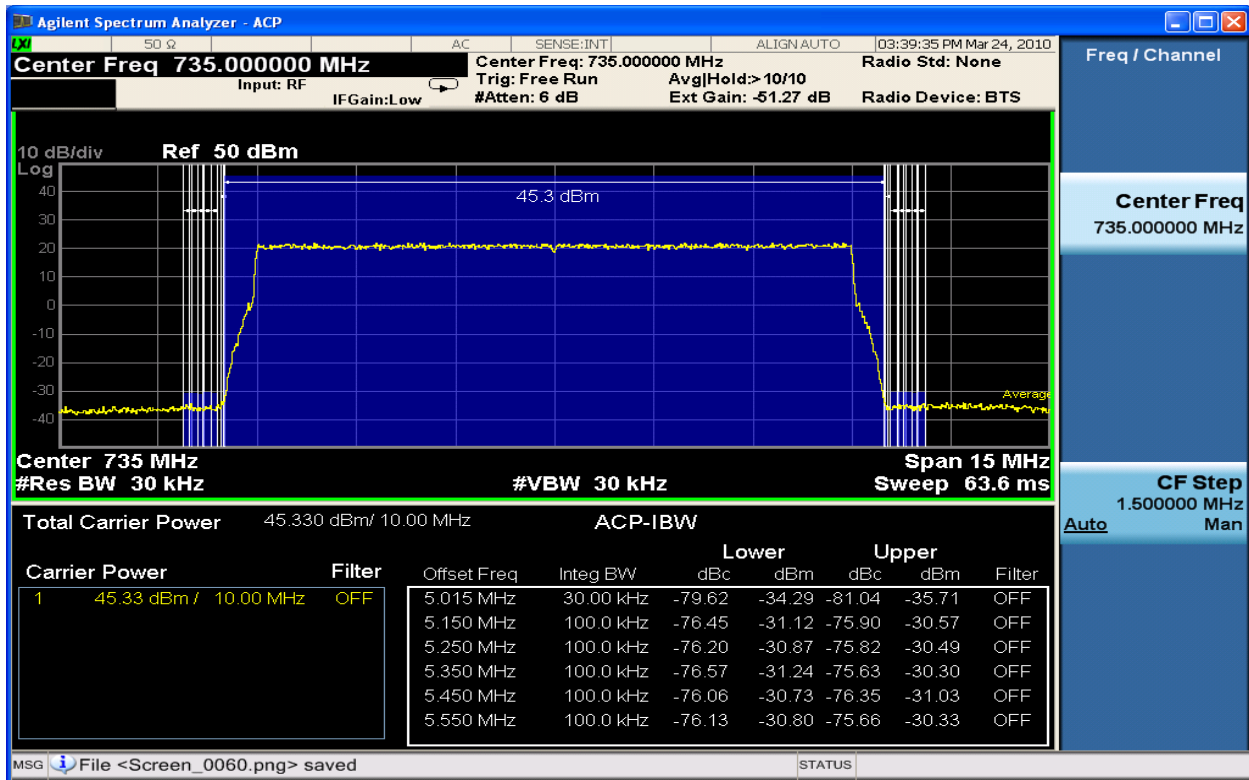

Figure 6-284 Spurious Emissions 735MHz TX2_64QAM 10MHz Band Edge (ACP 15kHz – 550KHz)

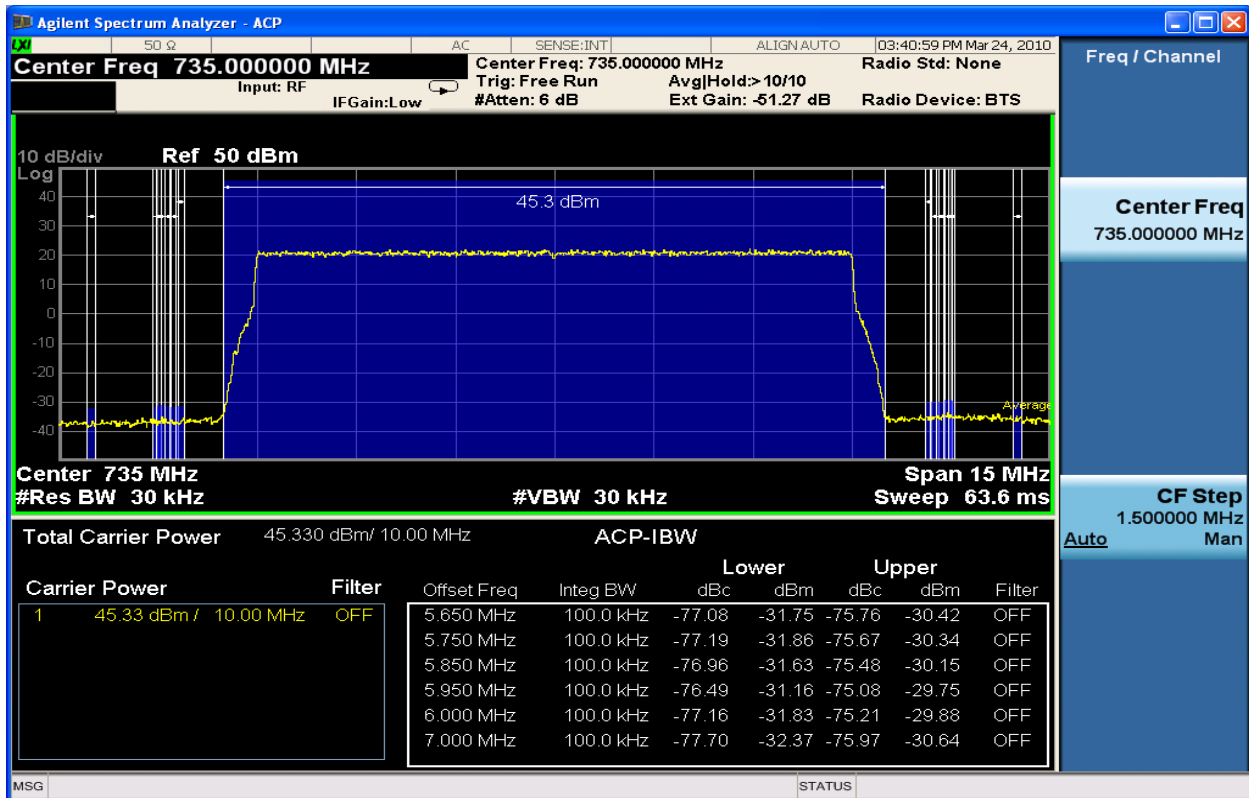

Figure 6-285 Spurious Emissions 735MHz TX2_64QAM 10MHz Band Edge (ACP 650kHz – 2MHz)

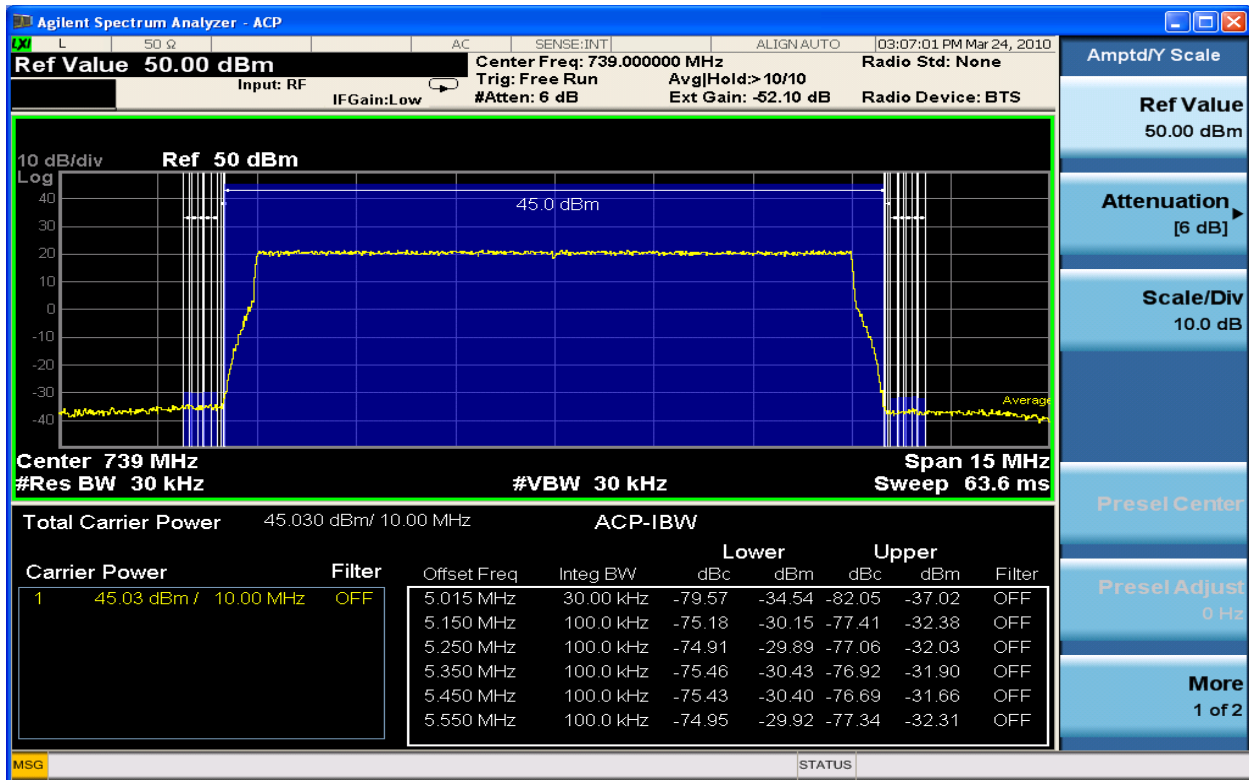

Figure 6-286 Spurious Emissions 739MHz TX1_QPSK 10MHz Band Edge (ACP 15kHz – 550KHz)

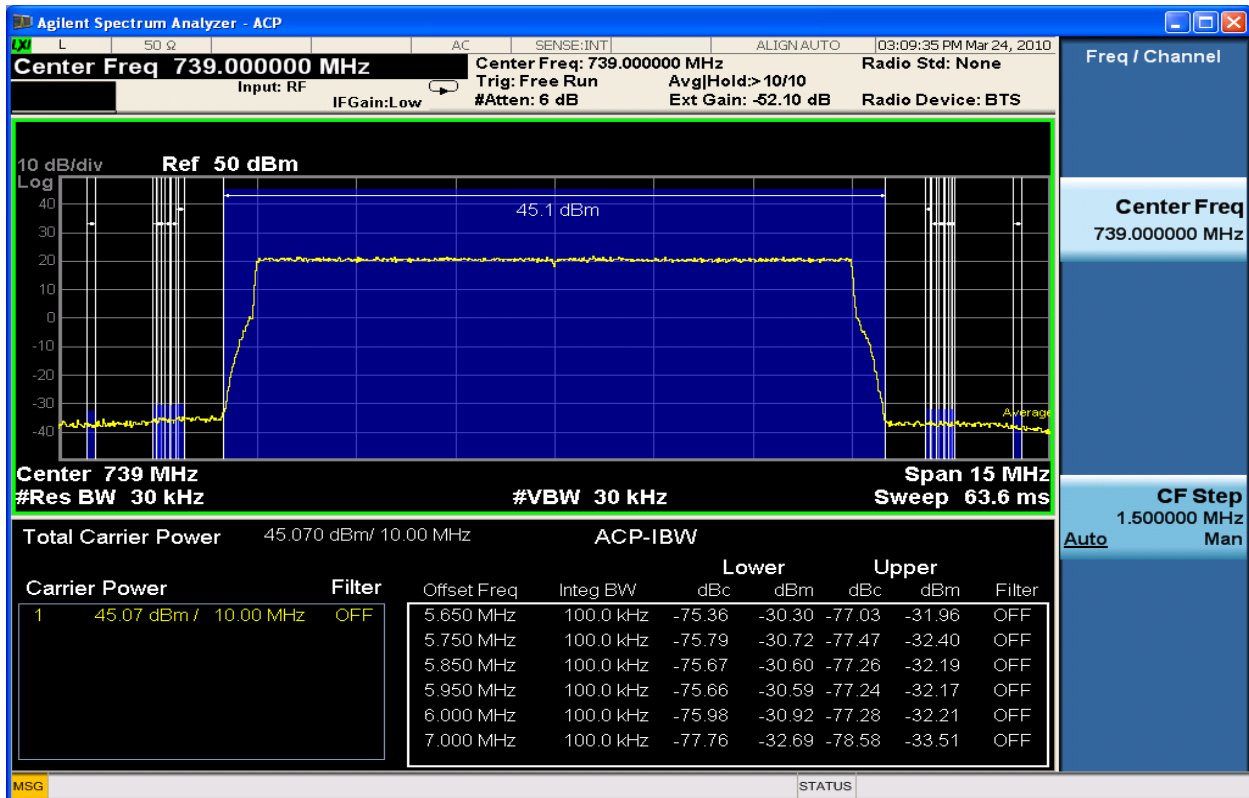

Figure 6-287 Spurious Emissions 739MHz TX1_QPSK 10MHz Band Edge (ACP 650kHz – 2MHz)

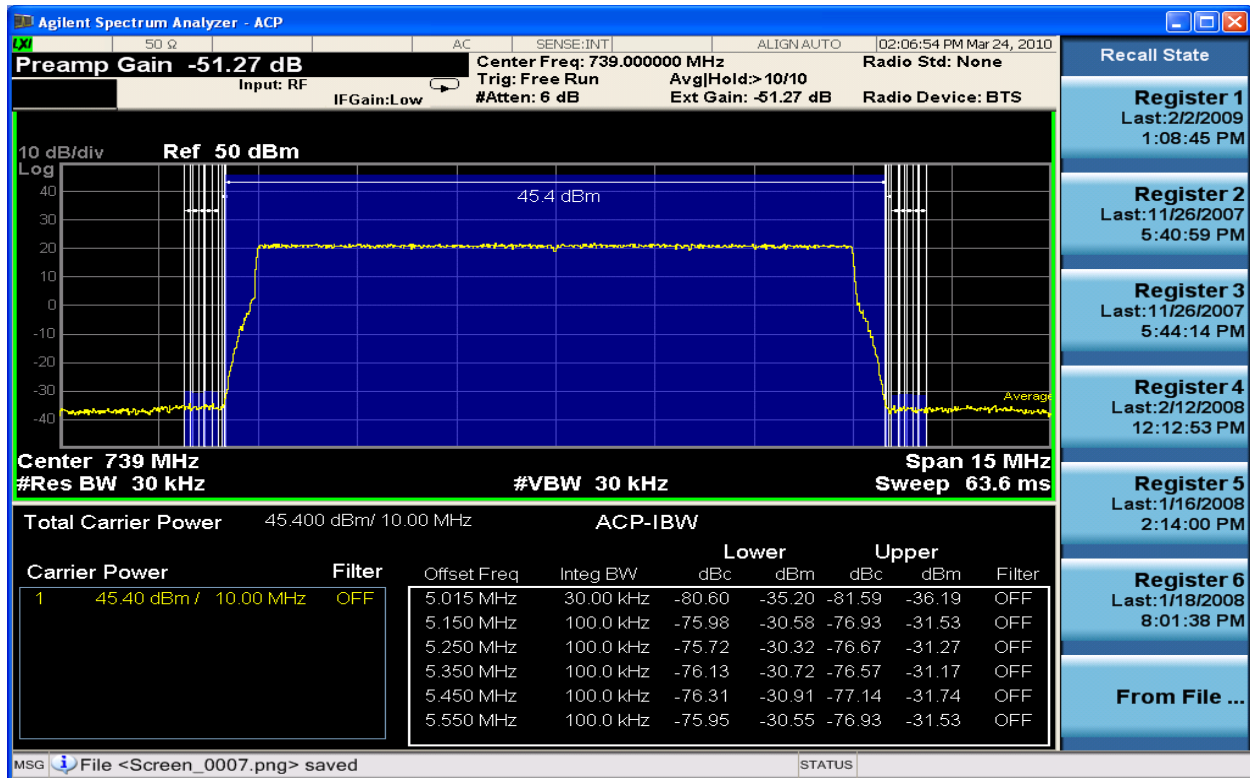

Figure 6-288 Spurious Emissions 739MHz TX2_QPSK 10MHz Band Edge (ACP 15kHz – 550KHz)

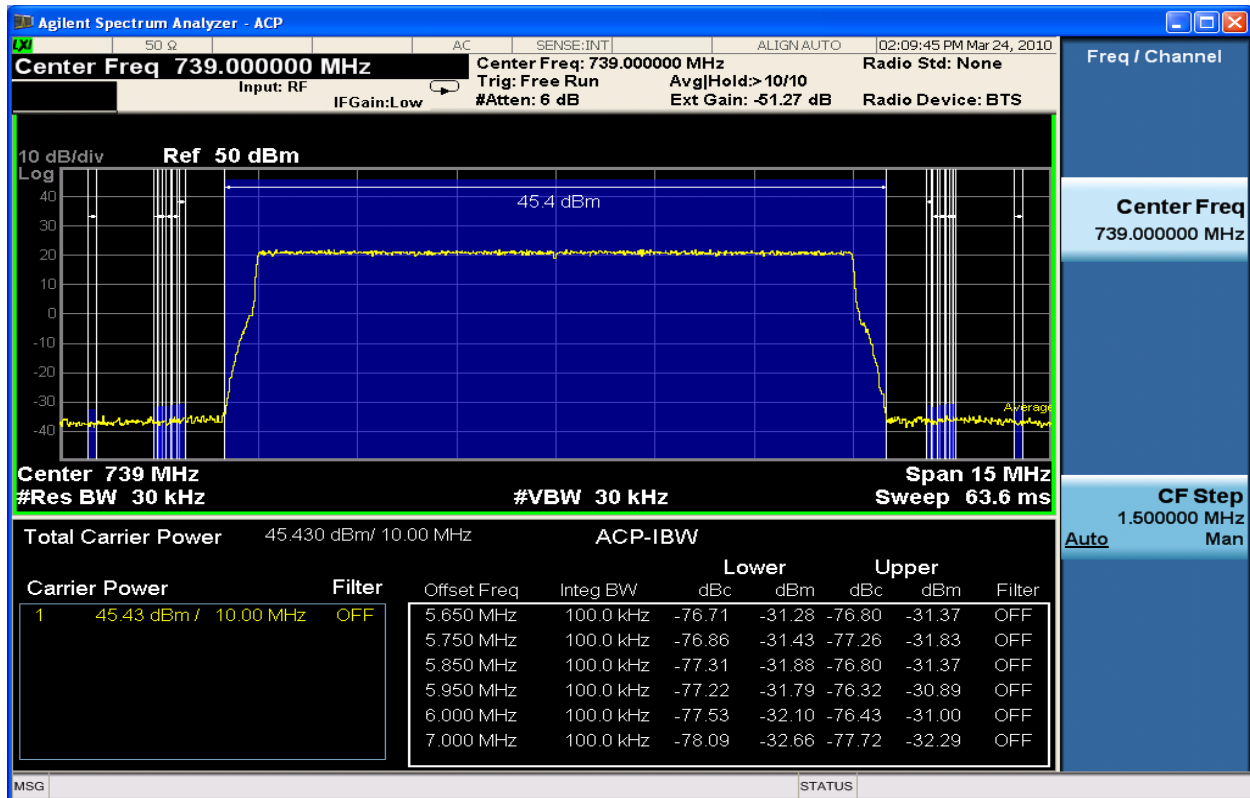

Figure 6-289 Spurious Emissions 739MHz TX2_QPSK 10MHz Band Edge (ACP 650kHz – 2MHz)

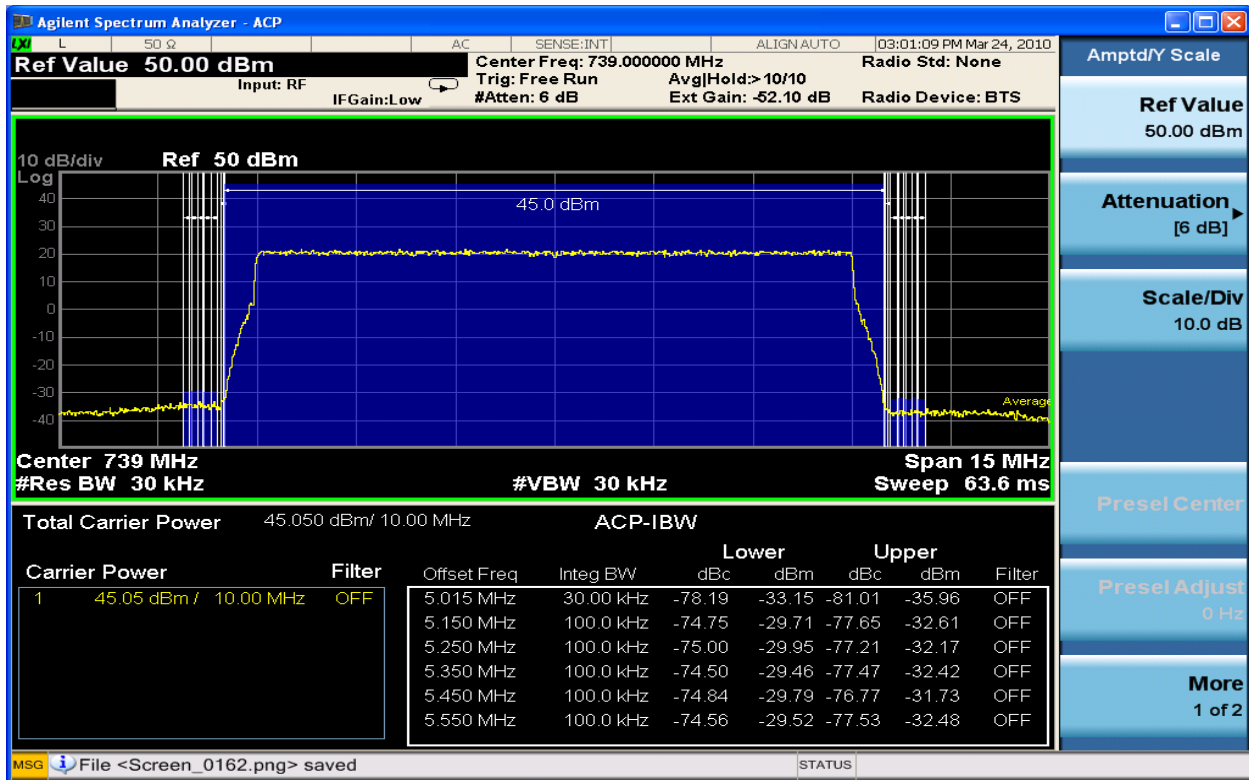

Figure 6-290 Spurious Emissions 739MHz TX1_16QAM 10MHz Band Edge (ACP 15kHz – 550KHz)

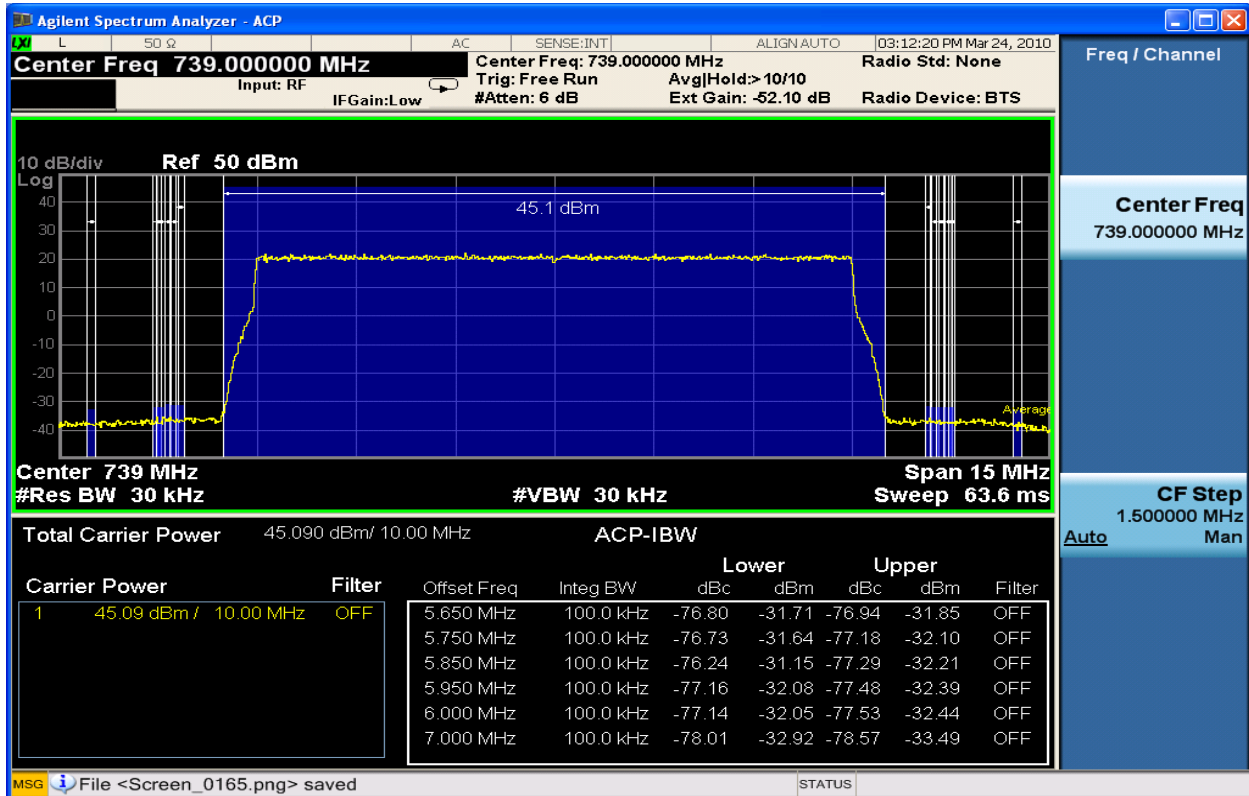

Figure 6-291 Spurious Emissions 739MHz TX1_16QAM 10MHz Band Edge (ACP 650kHz – 2MHz)

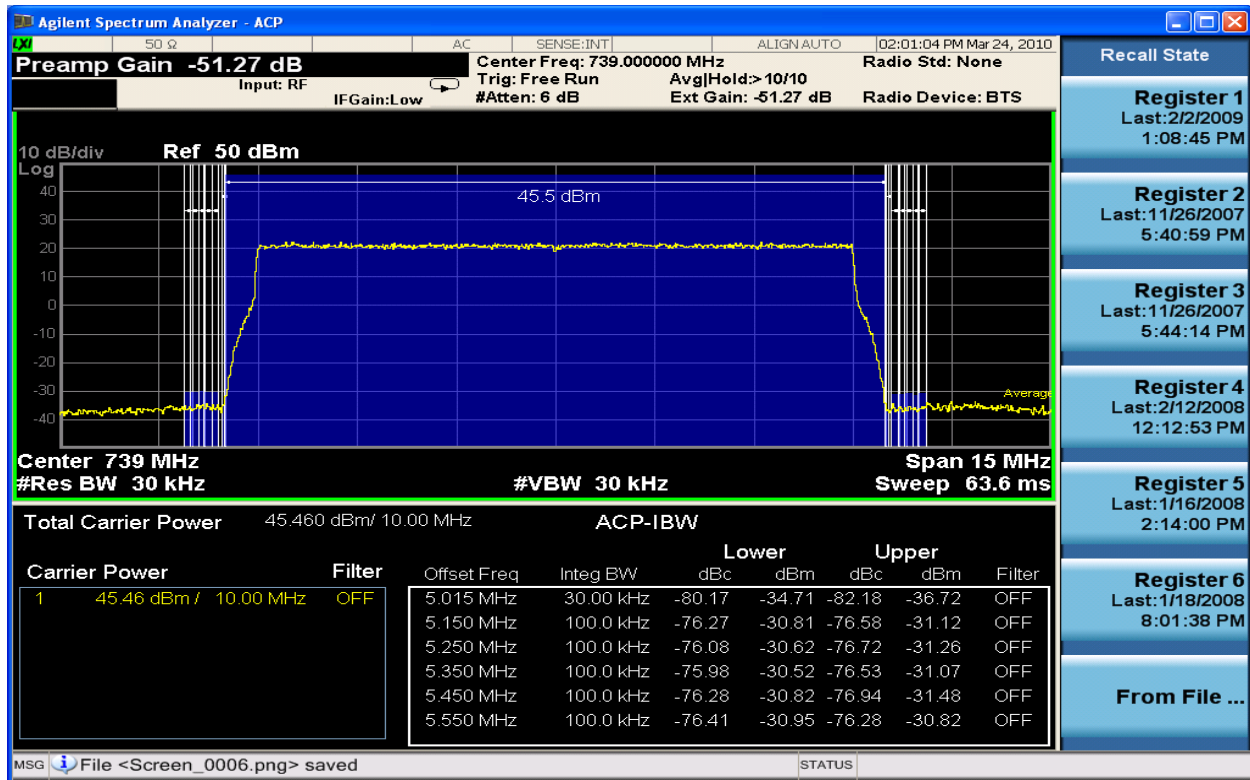

Figure 6-292 Spurious Emissions 739MHz TX2_16QAM 10MHz Band Edge (ACP 15kHz – 550KHz)

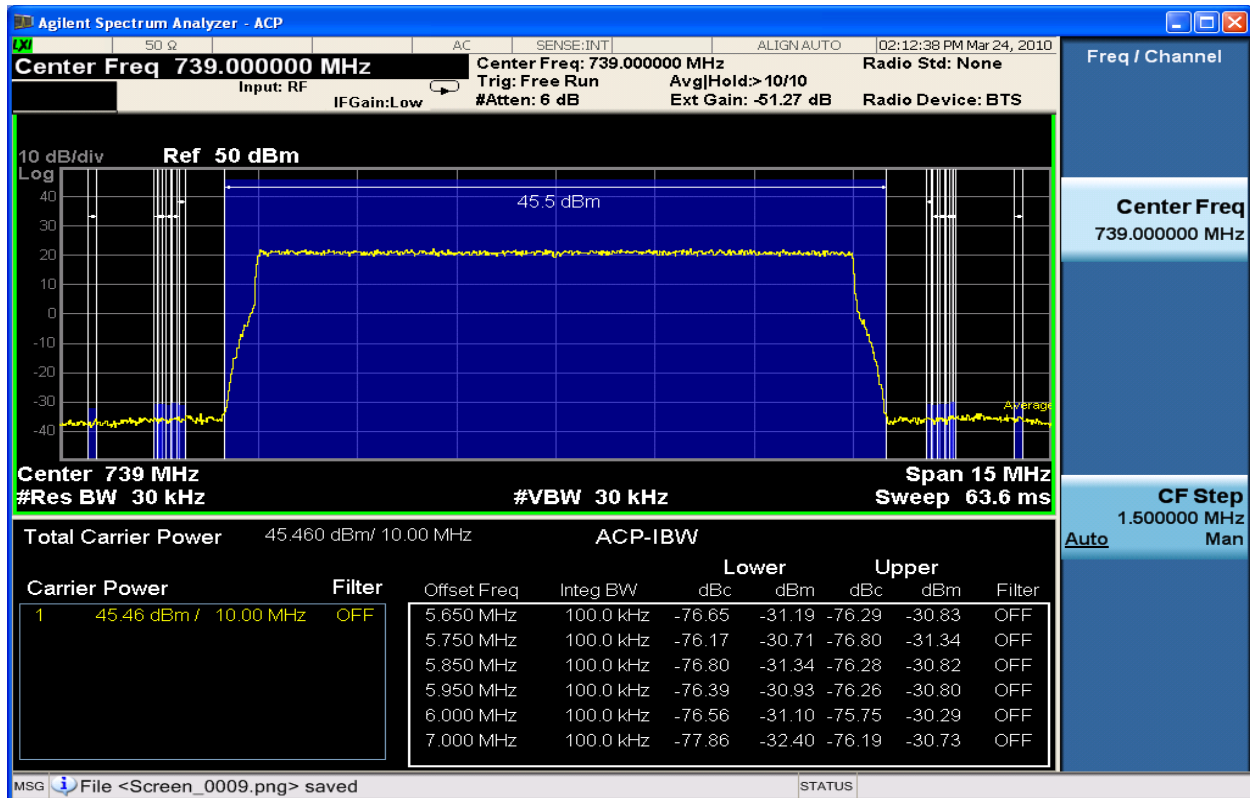

Figure 6-293 Spurious Emissions 739MHz TX2_16QAM 10MHz Band Edge (ACP 650kHz – 2MHz)

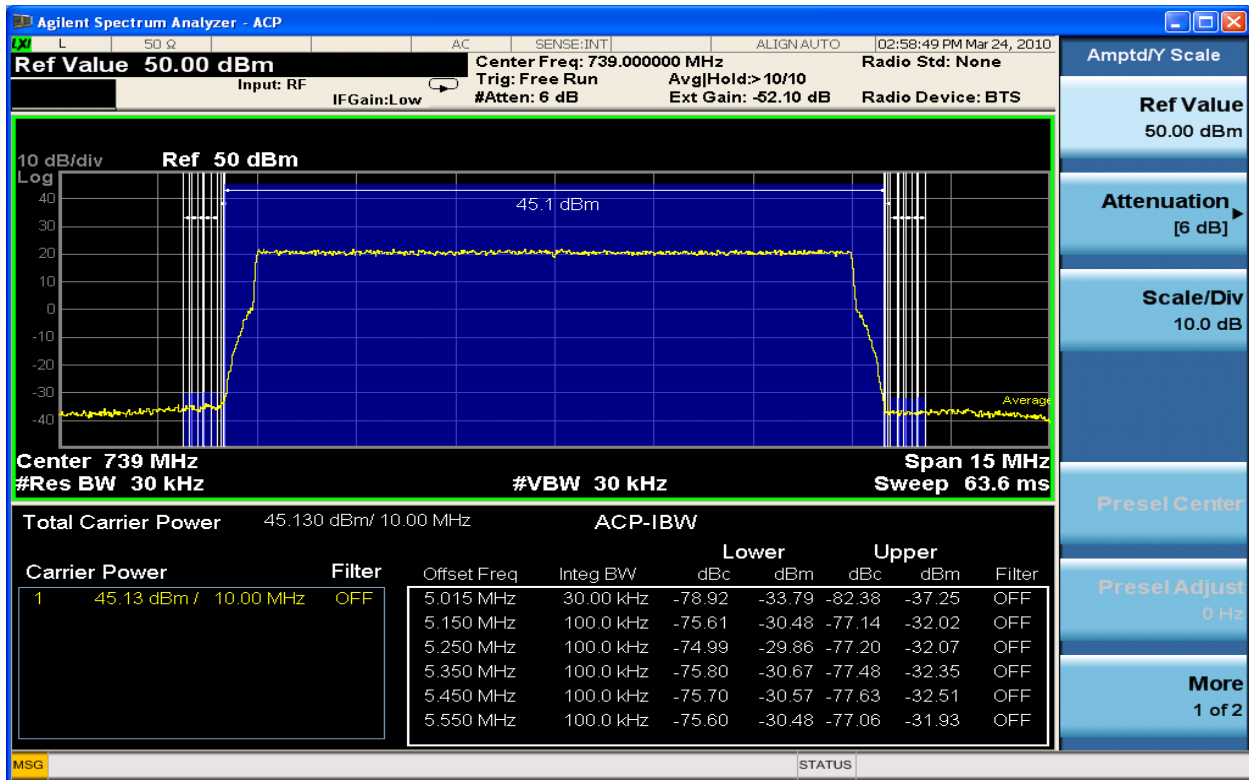

Figure 6-294 Spurious Emissions 739MHz TX1_64QAM 10MHz Band Edge (ACP 15kHz – 550KHz)

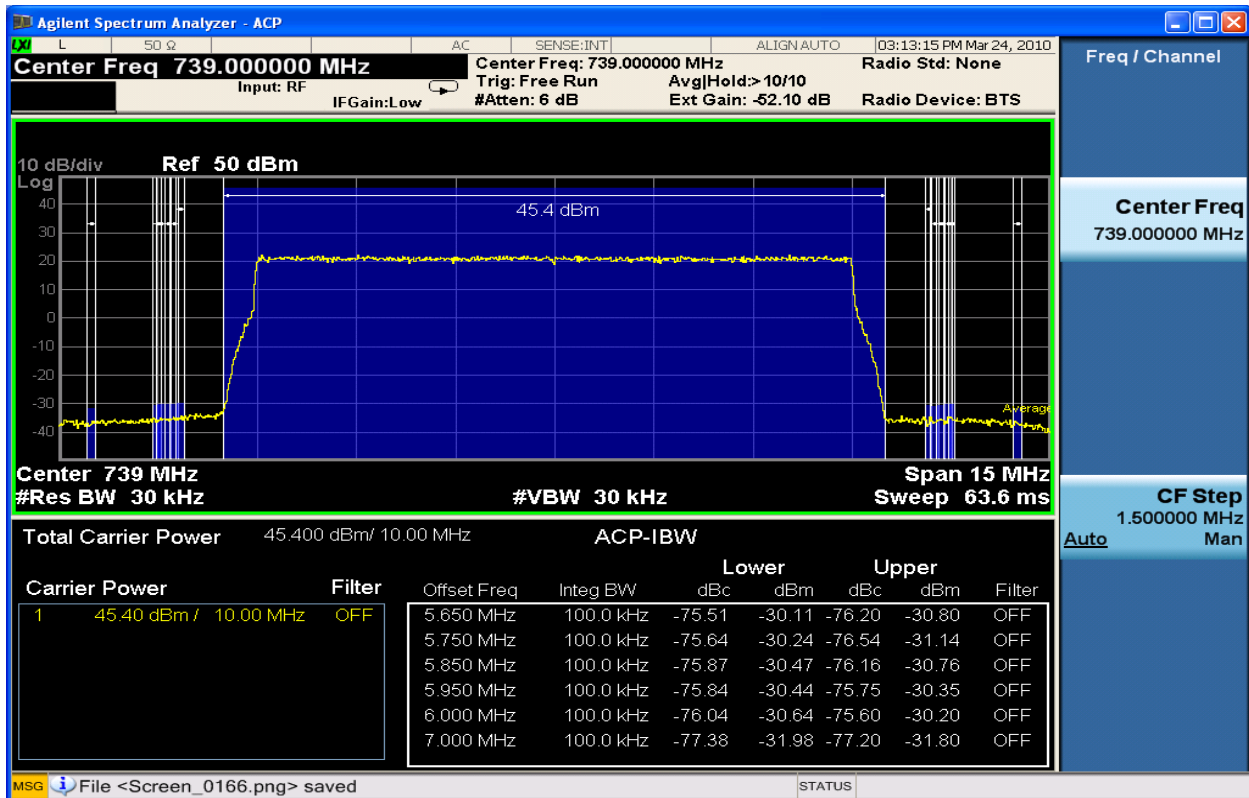

Figure 6-295 Spurious Emissions 739MHz TX1_64QAM 10MHz Band Edge (ACP 650kHz – 2MHz)

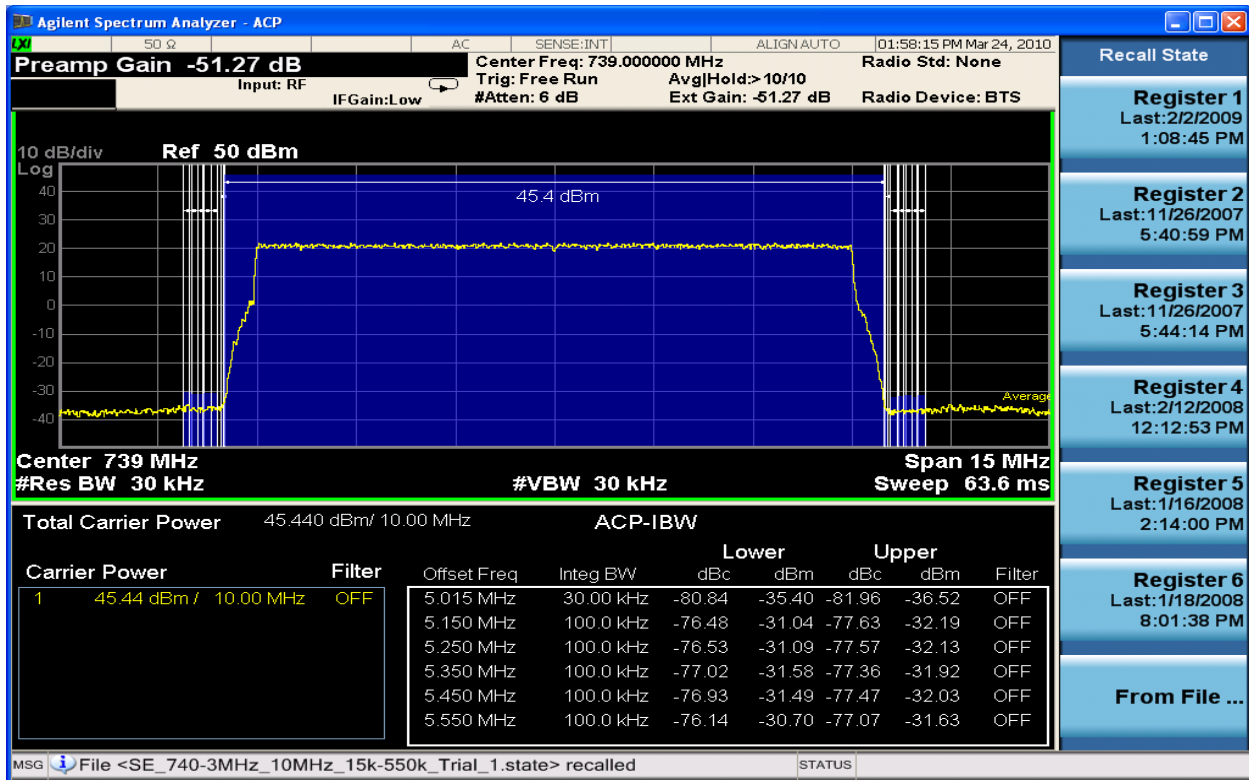

Figure 6-296 Spurious Emissions 739MHz TX2_64QAM 10MHz Band Edge (ACP 15kHz – 550KHz)

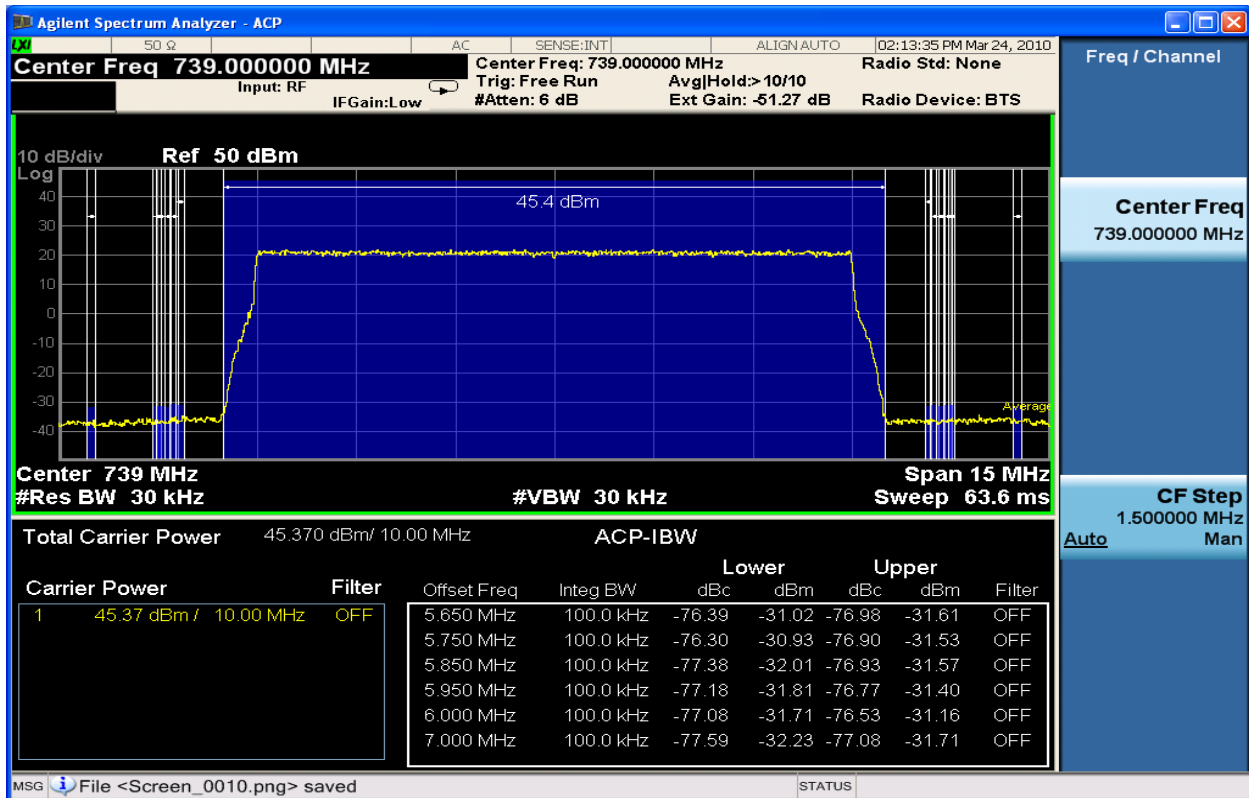

Figure 6-297 Spurious Emissions 739MHz TX2_64QAM 10MHz Band Edge (ACP 650kHz – 2MHz)

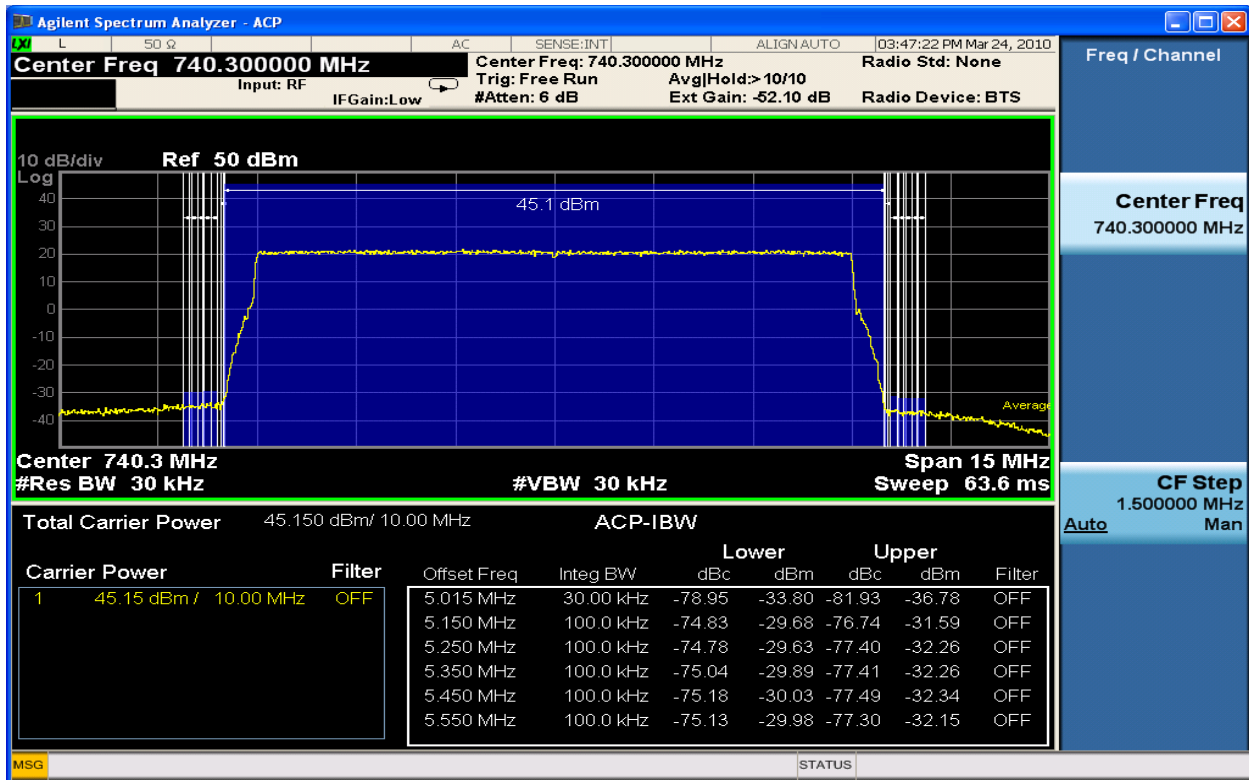

Figure 6-298 Spurious Emissions 740.3MHz TX1_QPSK 10MHz Band Edge (ACP 15kHz – 550kHz)

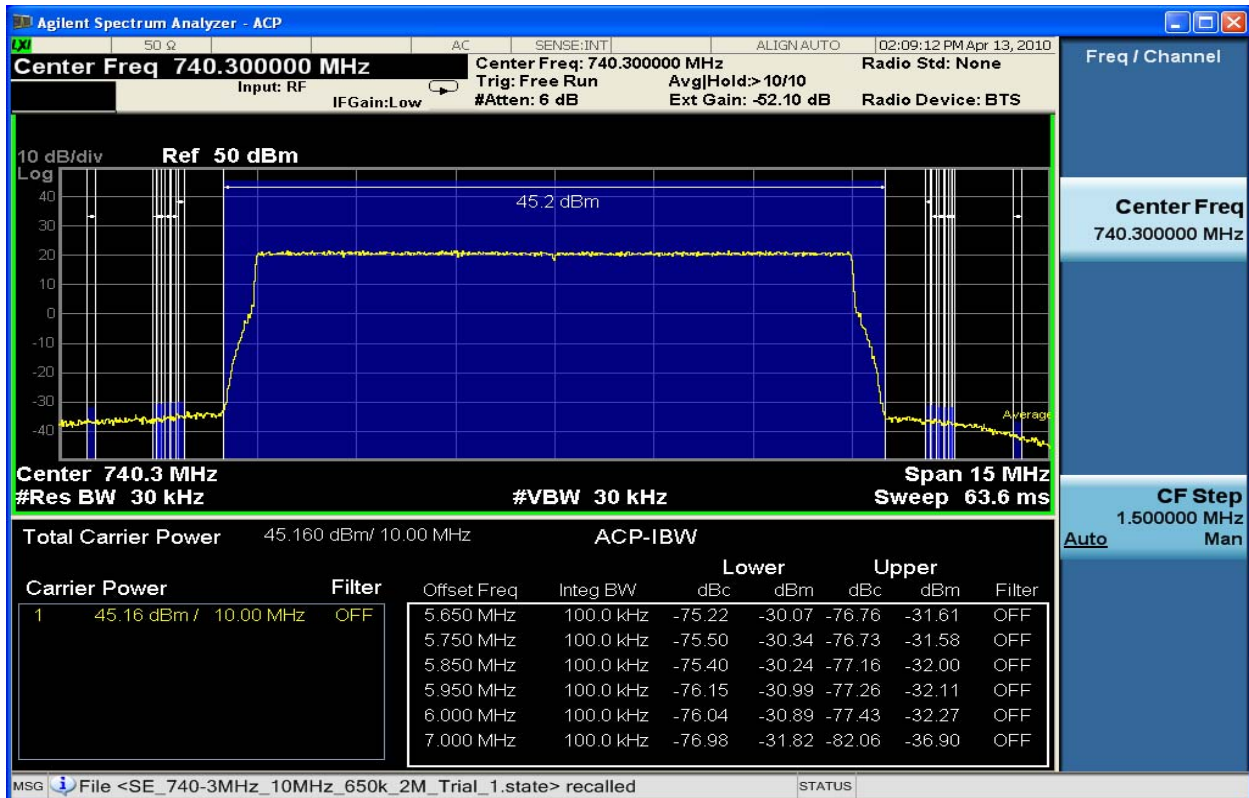

Figure for Spurious Emissions 740.3MHz TX1_QPSK 10MHz Band Edge (ACP 650kHz – 2MHz)

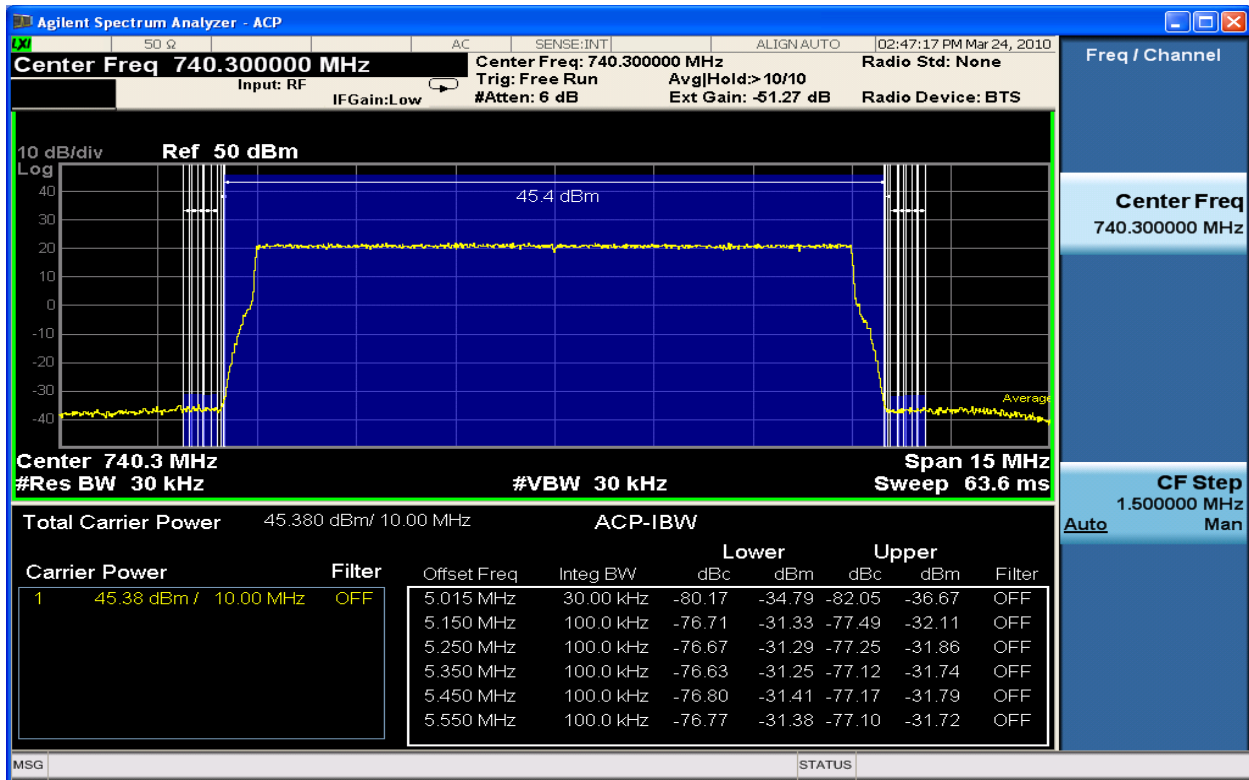

Figure 6-299 Spurious Emissions 740.3MHz TX2_QPSK 10MHz Band Edge (ACP 15kHz – 550KHz)

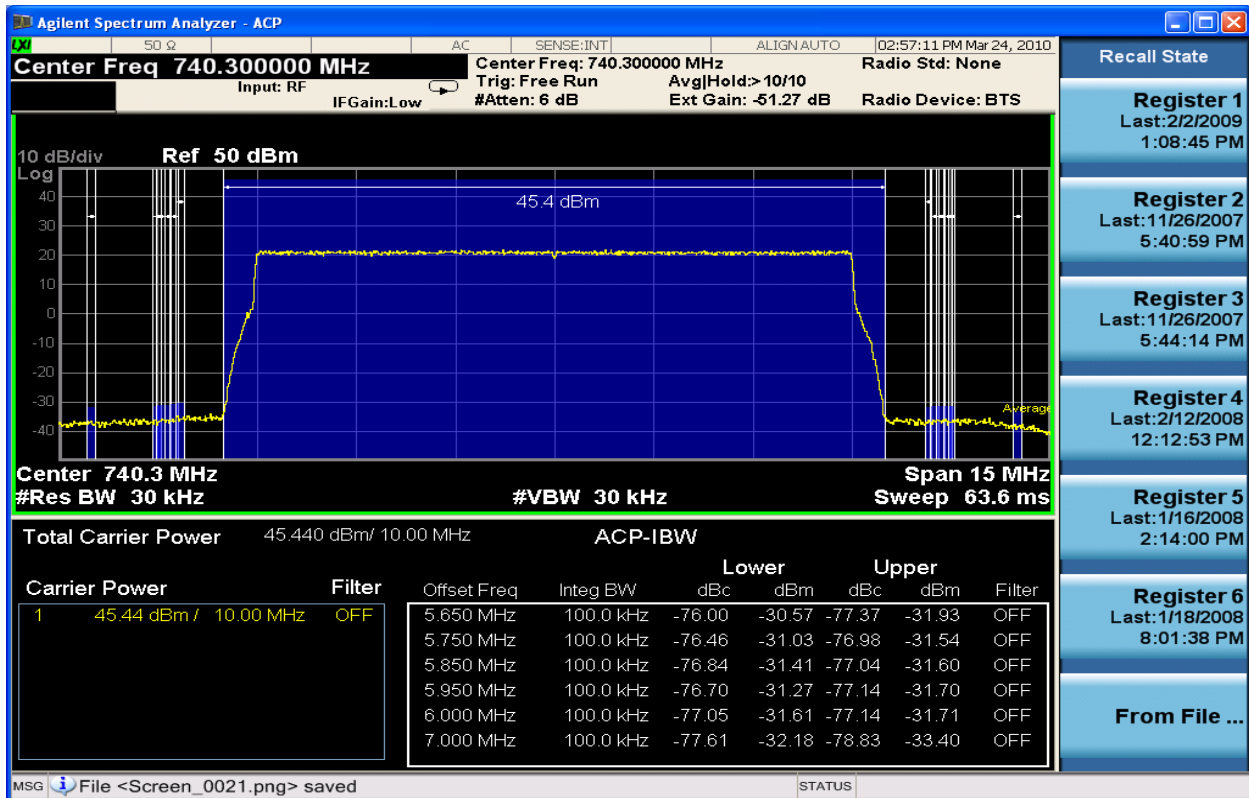

Figure 6-300 Spurious Emissions 740.3MHz TX2_QPSK 10MHz Band Edge (ACP 650kHz – 2MHz)

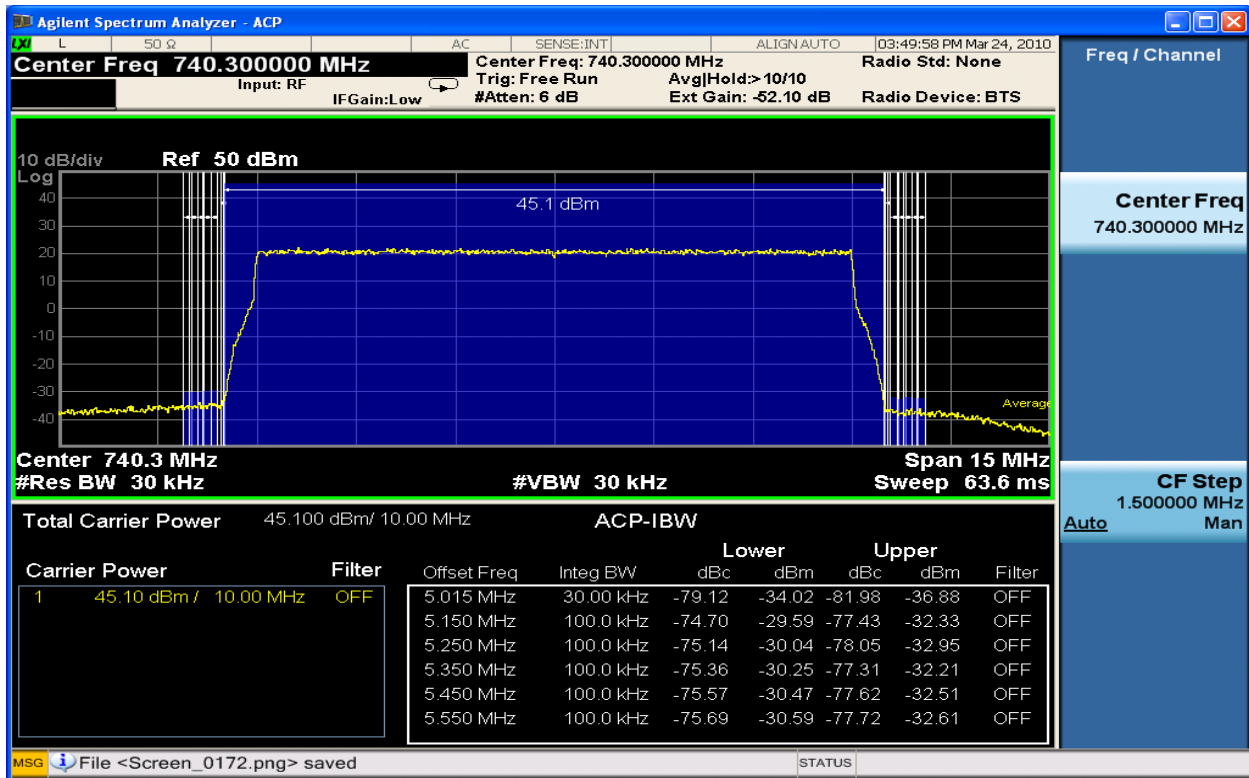

Figure 6-301 Spurious Emissions 740.3MHz TX1_16QAM 10MHz Band Edge (ACP 15kHz – 550kHz)

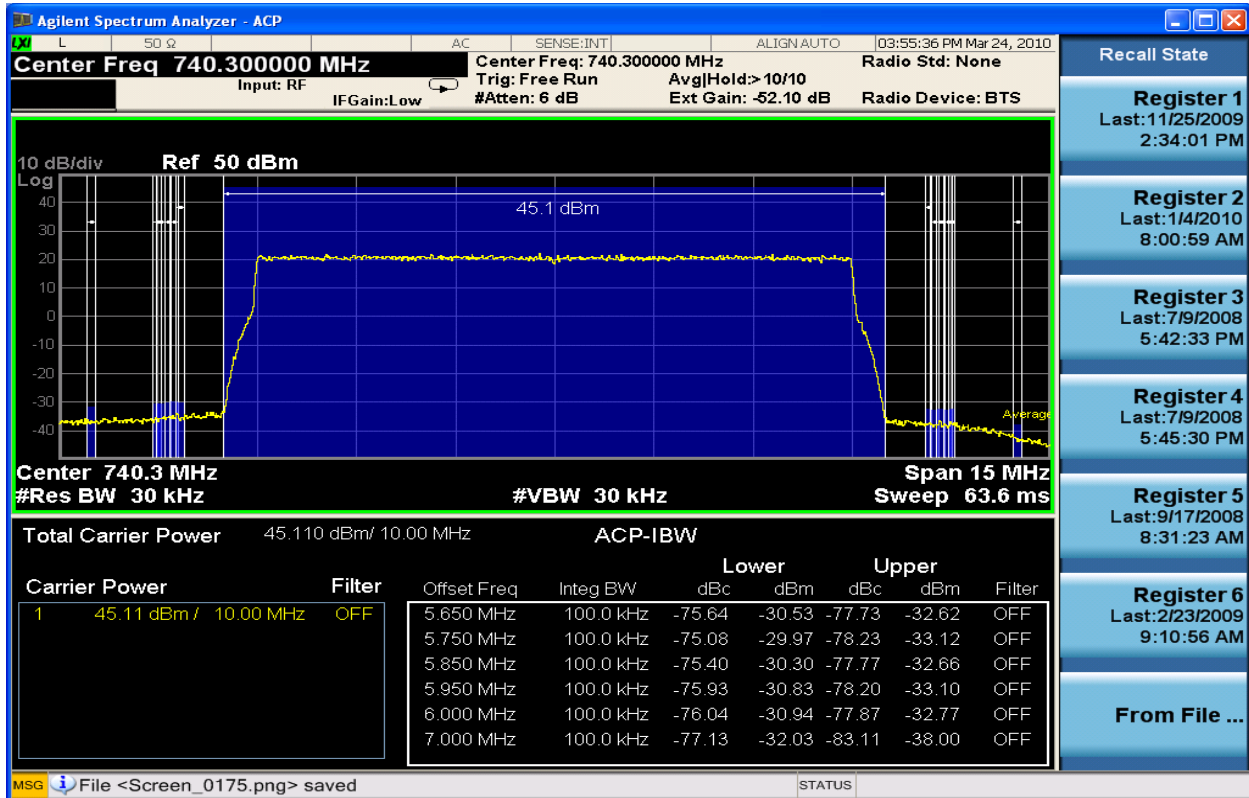

Figure 6-302 Emissions 740.3MHz TX1_16QAM 10MHz Band Edge (ACP 650kHz – 2MHz)

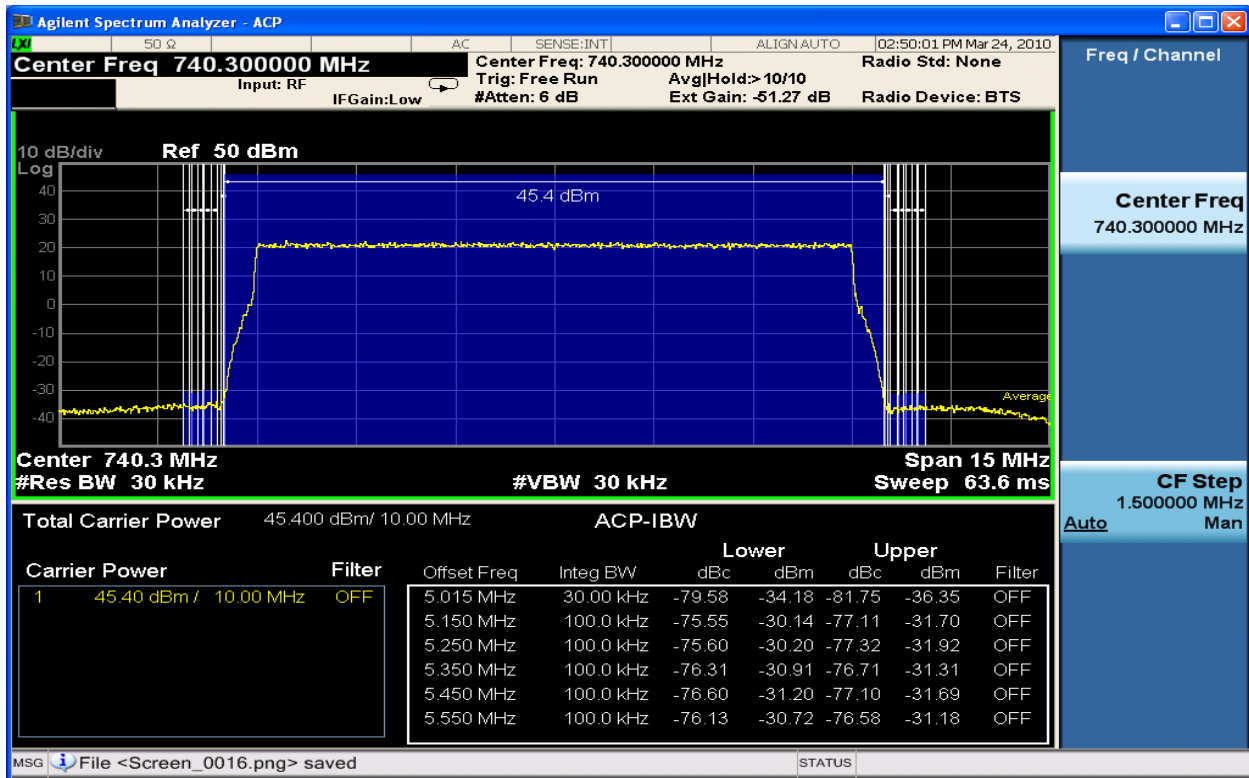

Figure 6-303 Spurious Emissions 740.3MHz TX2_16QAM 10MHz Band Edge (ACP 15kHz – 550kHz)

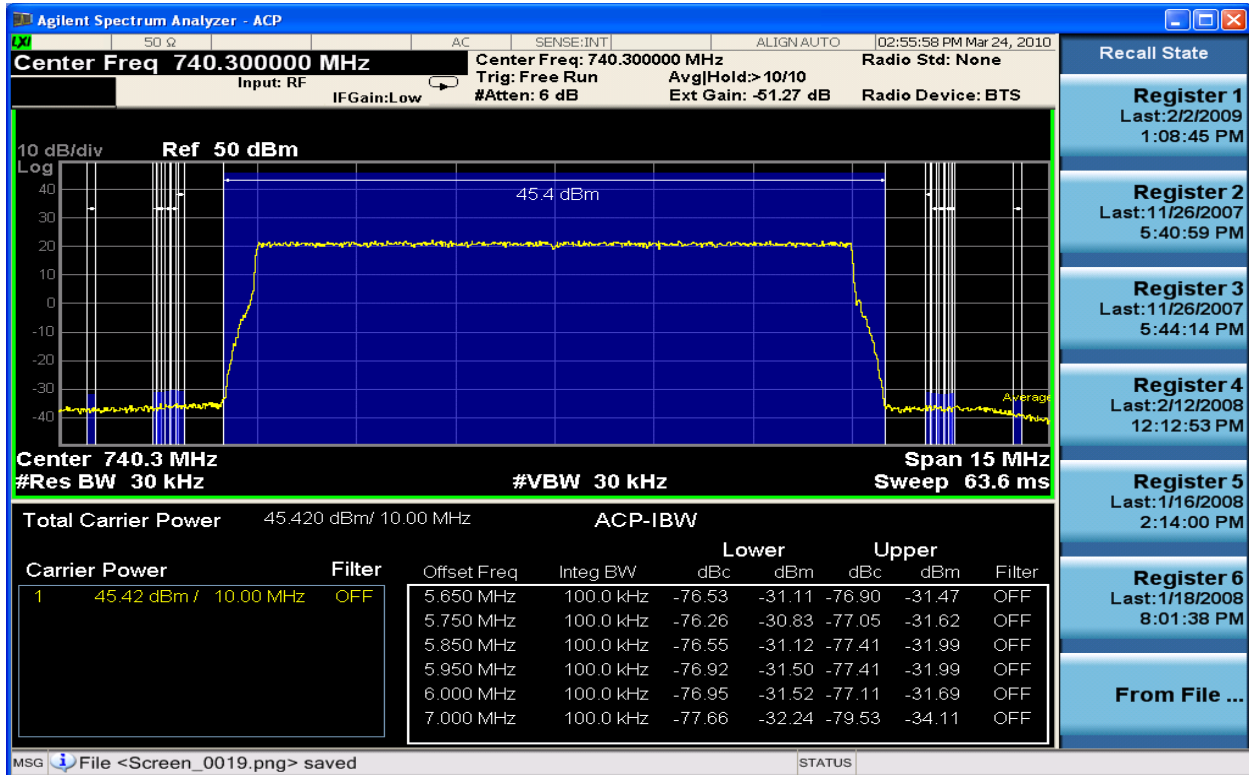

Figure 6-304 Spurious Emissions 740.3MHz TX2_16QAM 10MHz Band Edge (ACP 650kHz – 2MHz)

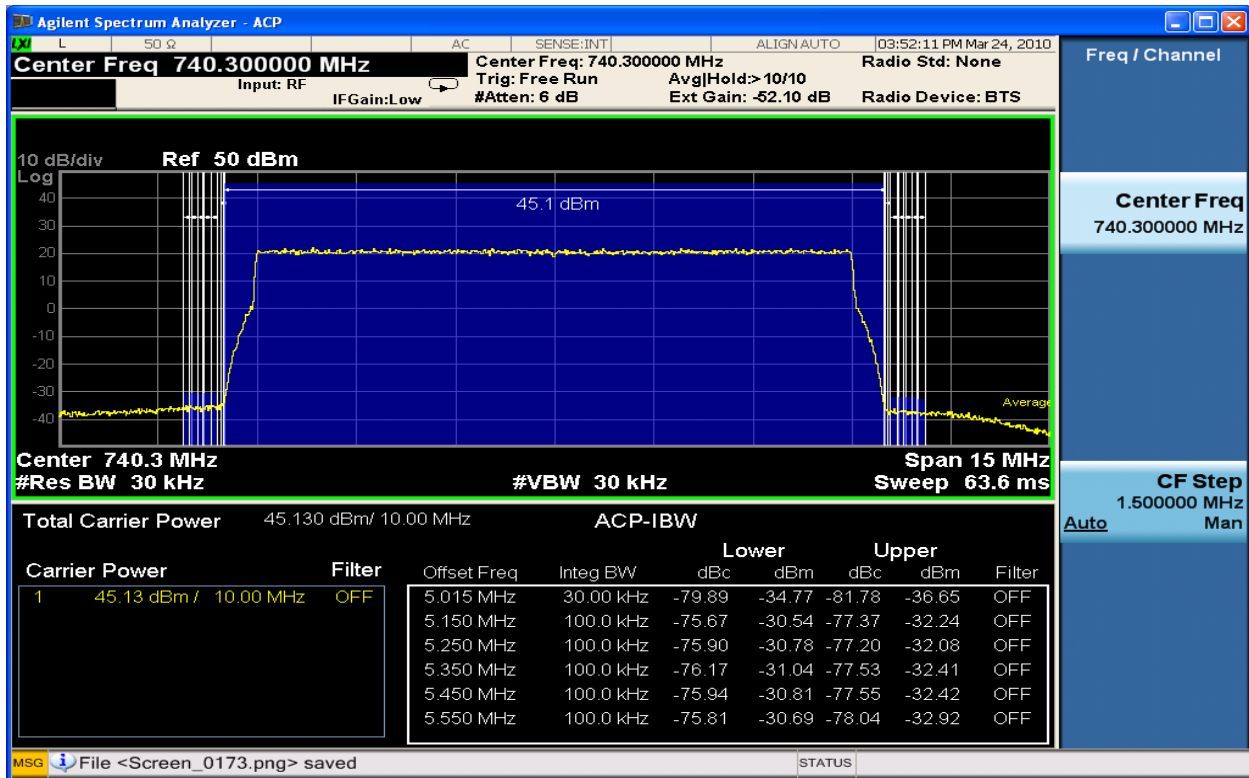

Figure 6-305 Spurious Emissions 740.3MHz TX1_64QAM 10MHz Band Edge (ACP 15kHz – 550kHz)

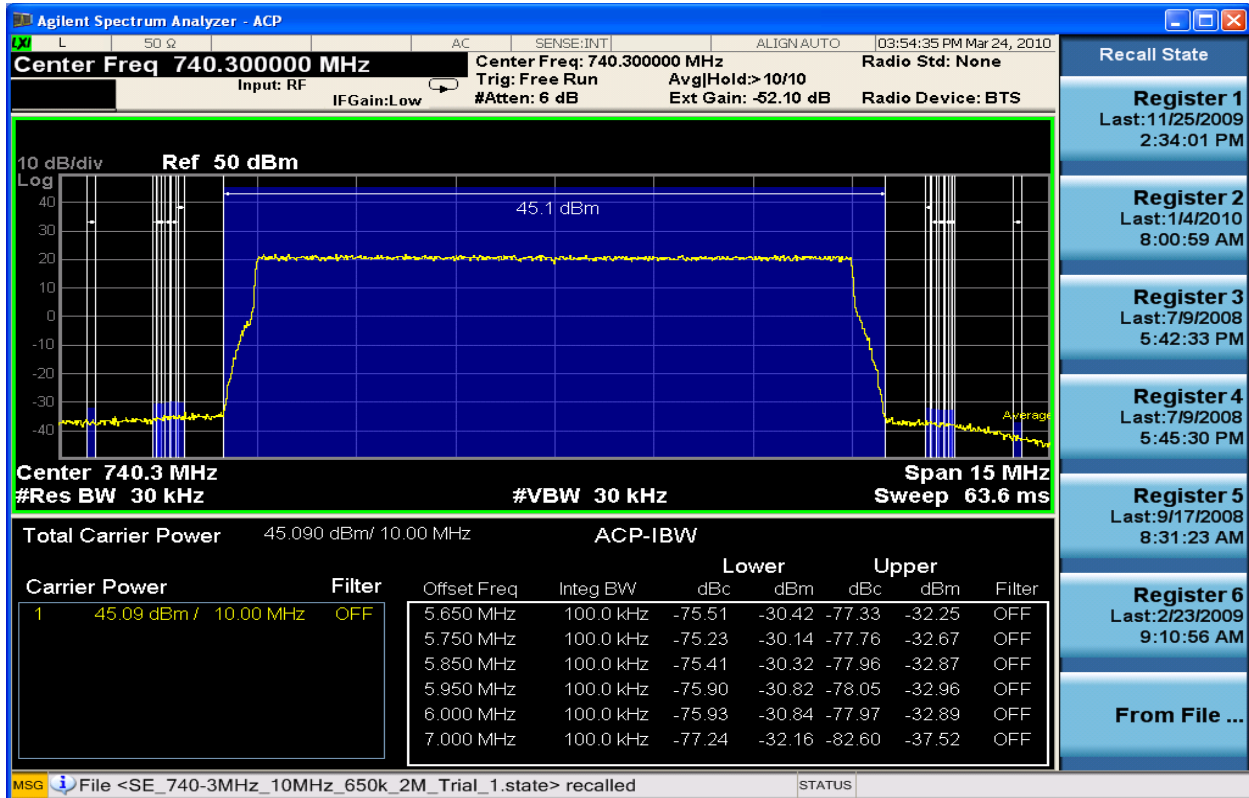

Figure 6-306 Spurious Emissions 740.3MHz TX1_64QAM 10MHz Band Edge (ACP 650kHz – 2MHz)

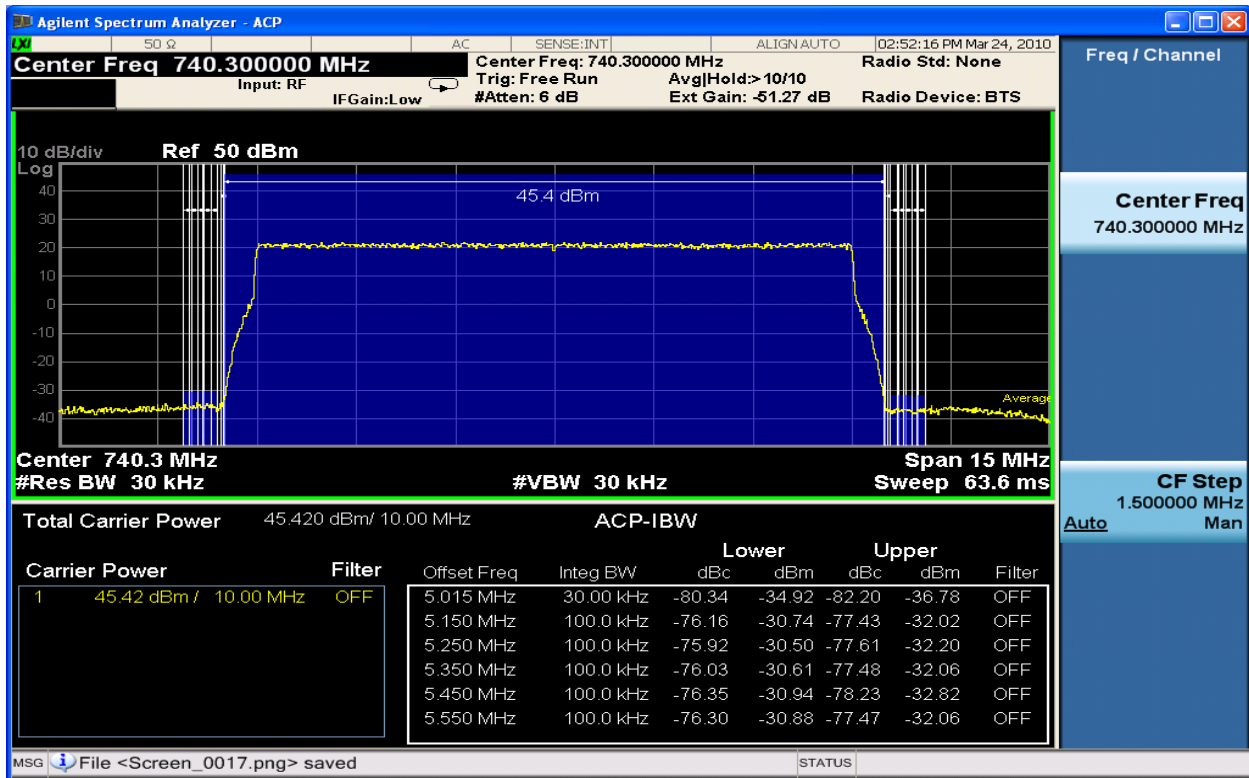

Figure 6-307 Spurious Emissions 740.3MHz TX2_64QAM 10MHz Band Edge (ACP 15kHz – 550KHz)

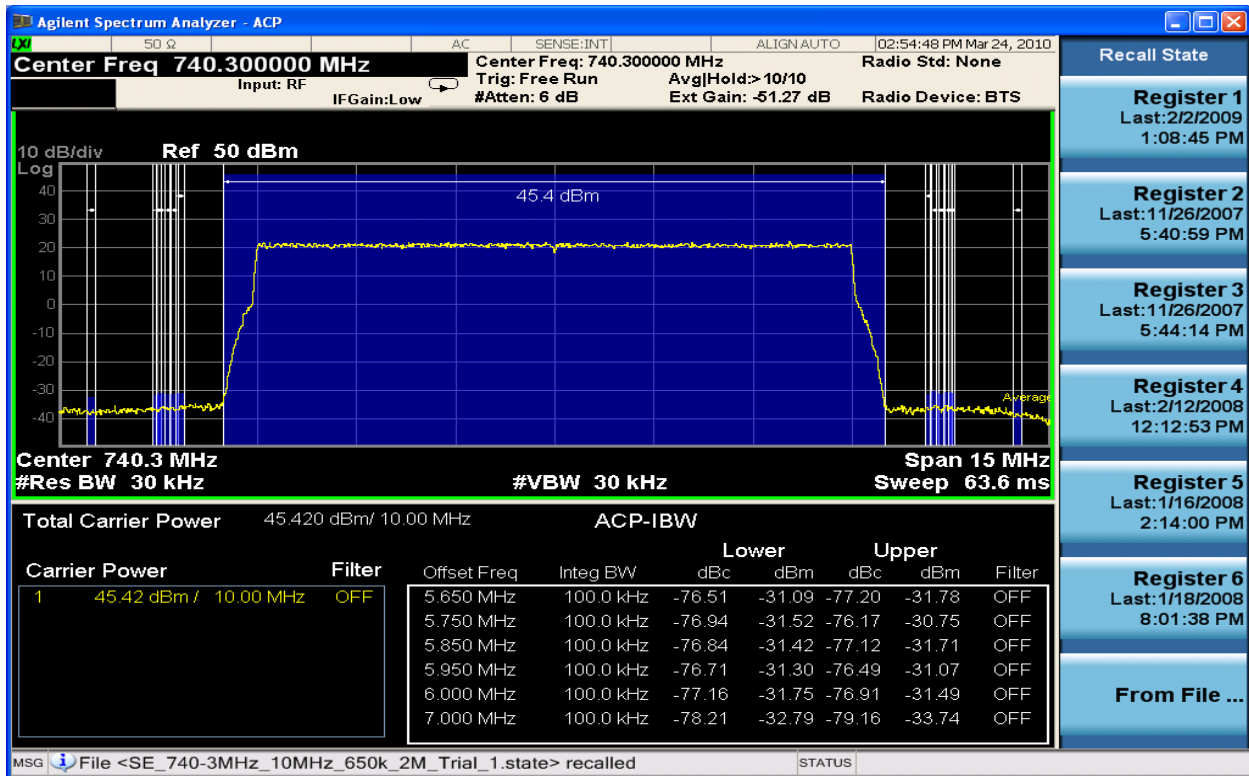

Figure 6-308 Spurious Emissions 740.3MHz TX2_64QAM 10MHz Band Edge (ACP 650kHz – 2MHz)

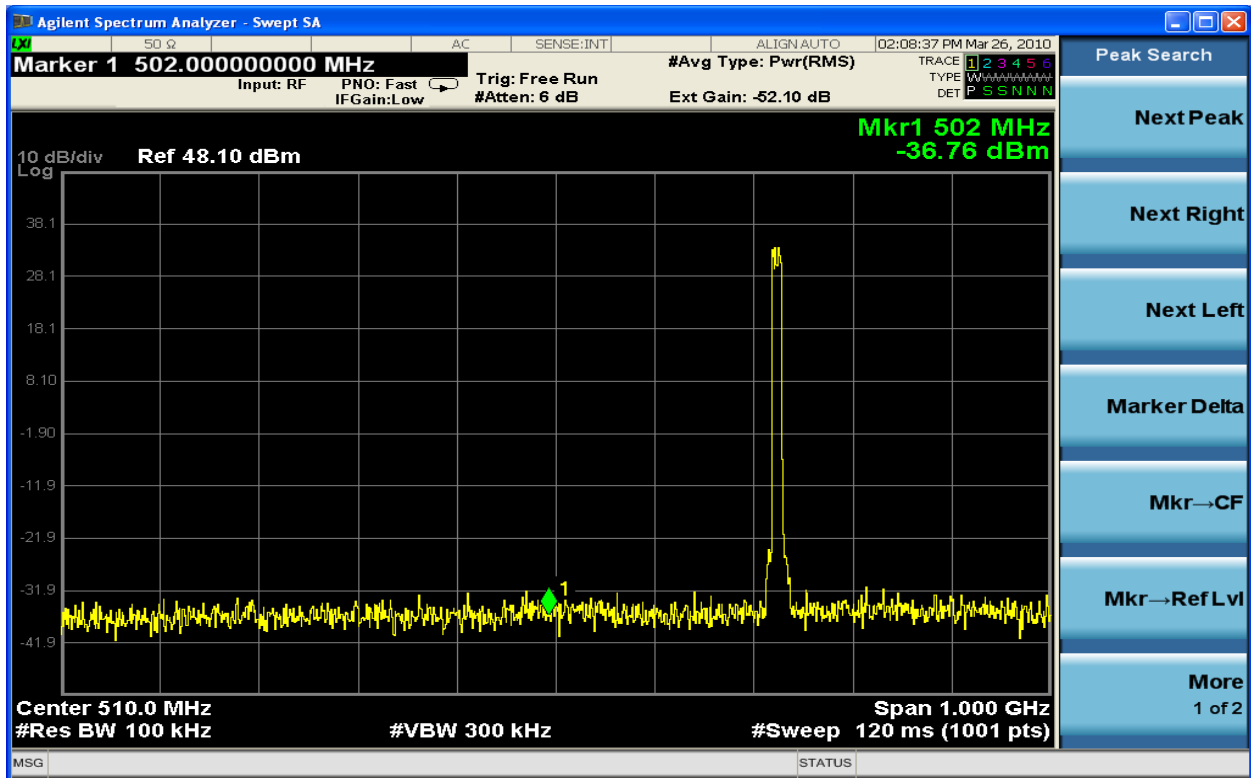

Figure 6-309 Spurious Emission TX1 QPSK 733.7MHz – 10MHz (10MHz-1.1GHz)

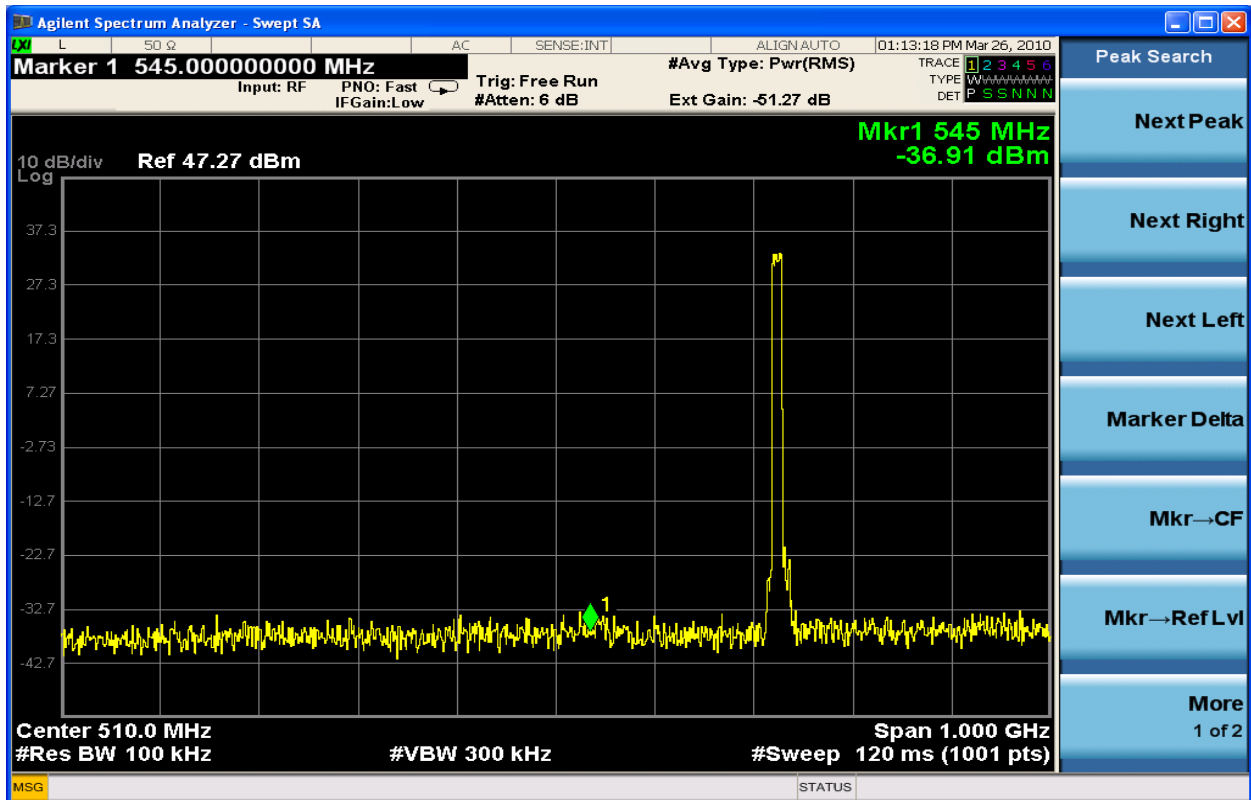

Figure 6-310 Spurious Emission TX2 QPSK 733.7MHz – 10MHz (10MHz-1.1GHz)

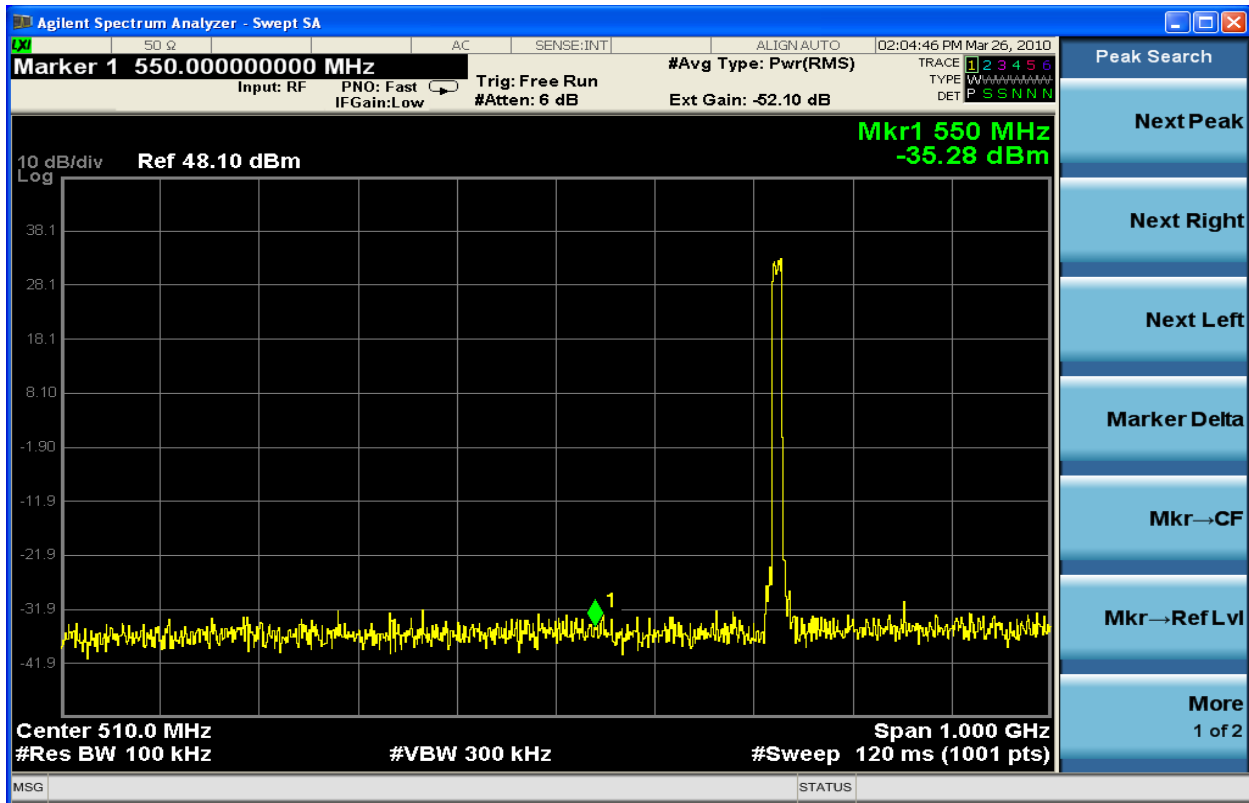

Figure 6-311 Spurious Emission TX1 16QAM 733.7MHz – 10MHz (10MHz-1.1GHz)

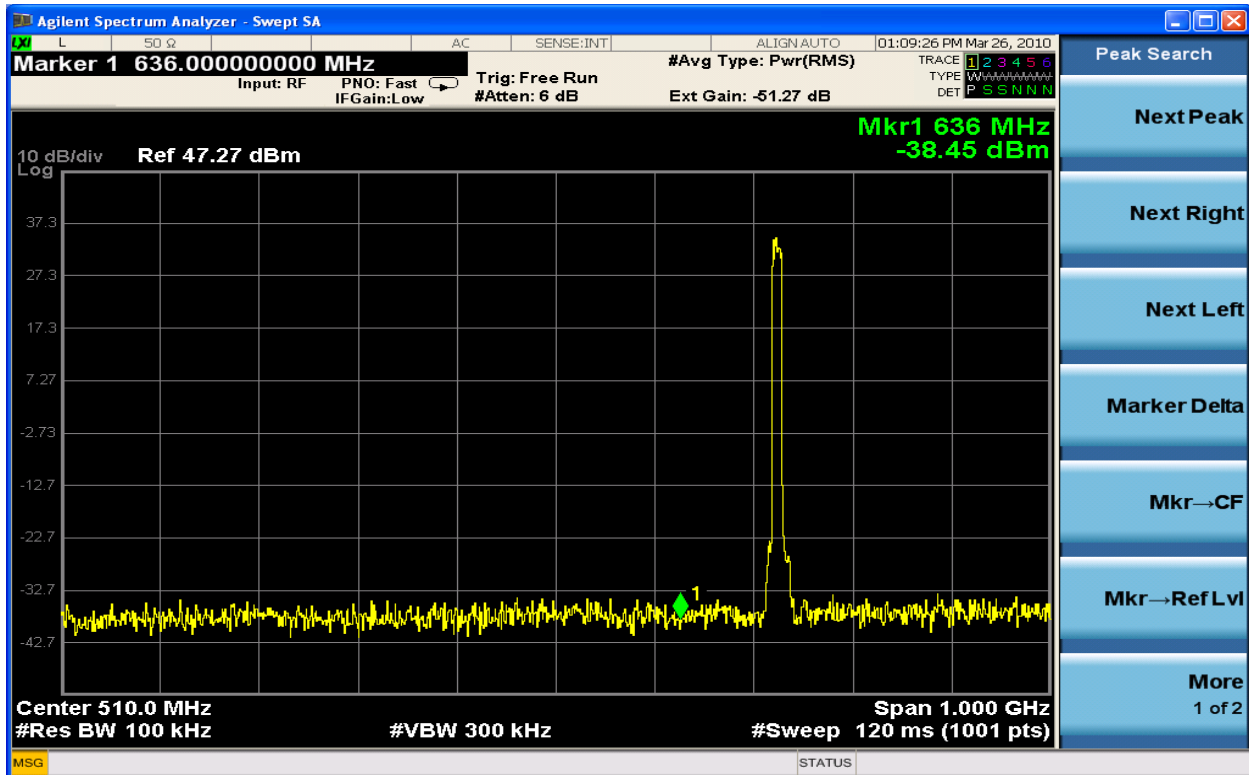

Figure 6-312 Spurious Emission TX2 16QAM 733.7MHz – 10MHz (10MHz-1.1GHz)

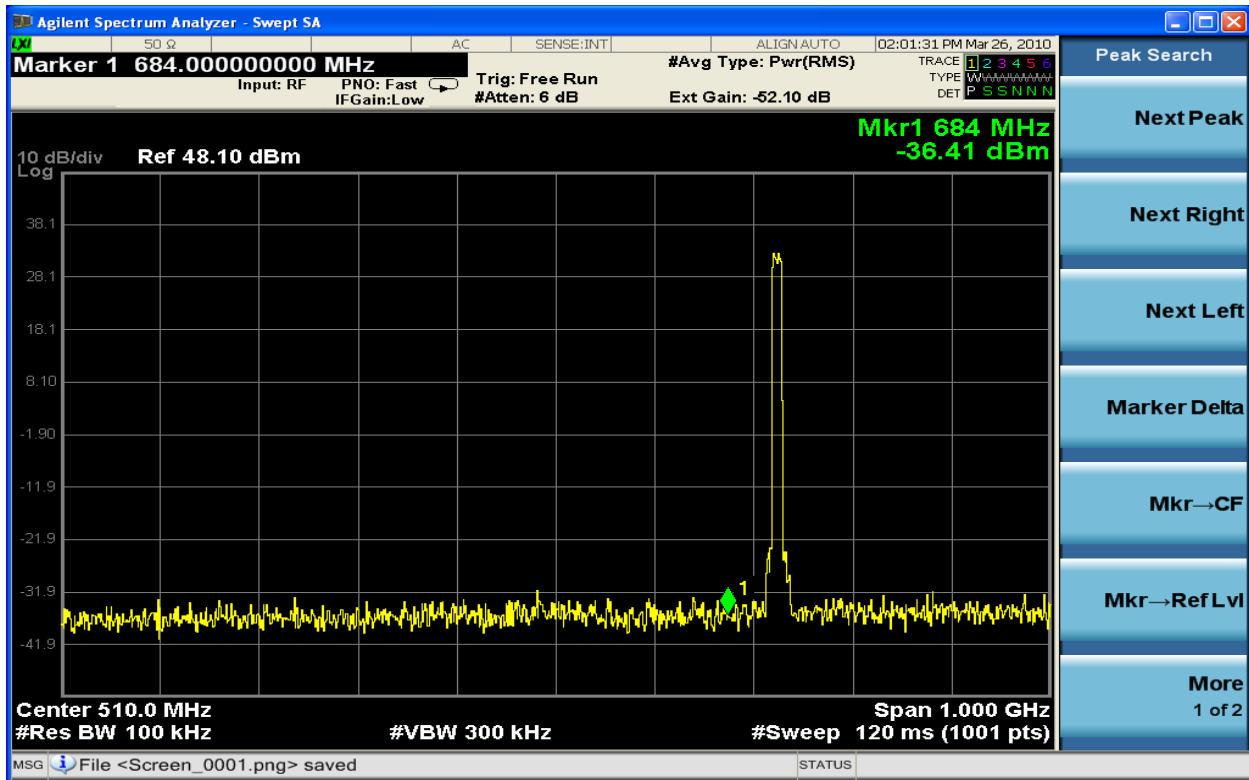

Figure 6-313 Spurious Emission TX1 64QAM 733.7MHz – 10MHz (10MHz-1.1GHz)

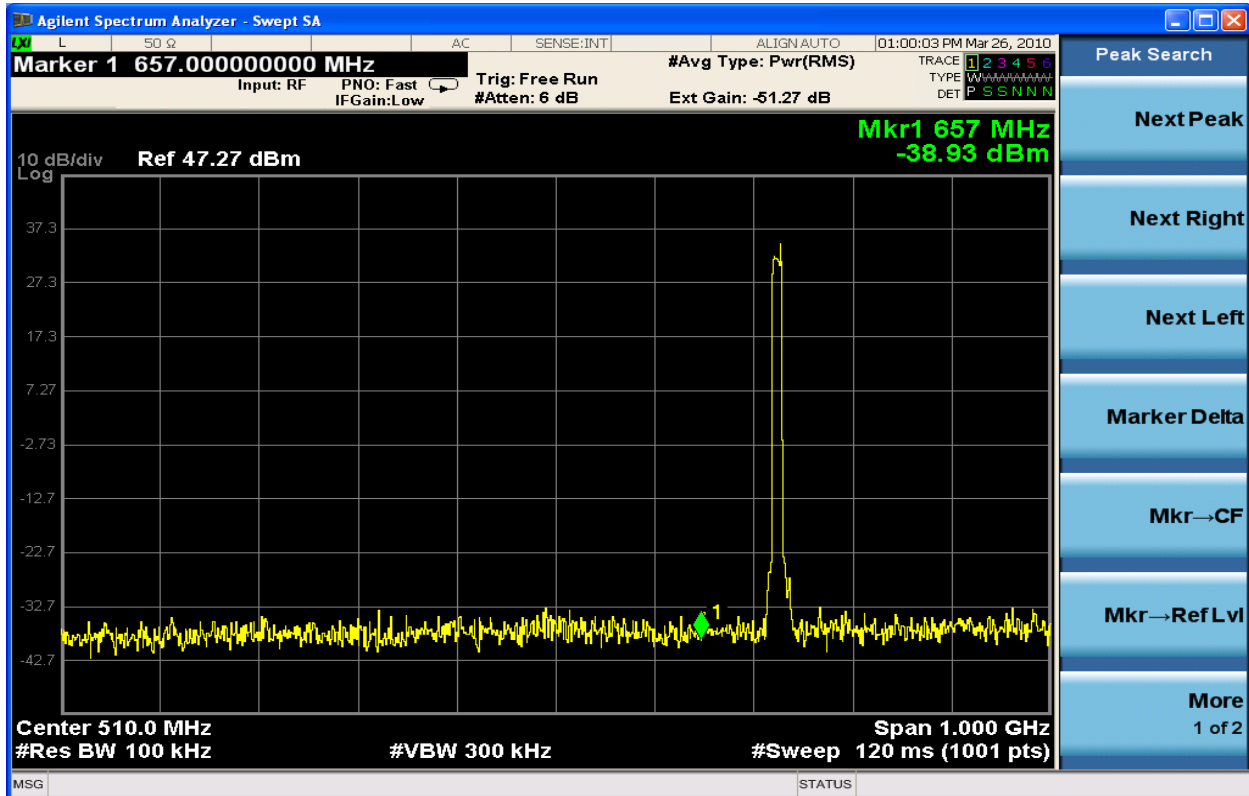

Figure 6-314 Spurious Emission TX2 64QAM 733.7MHz – 10MHz (10MHz-1.1GHz)

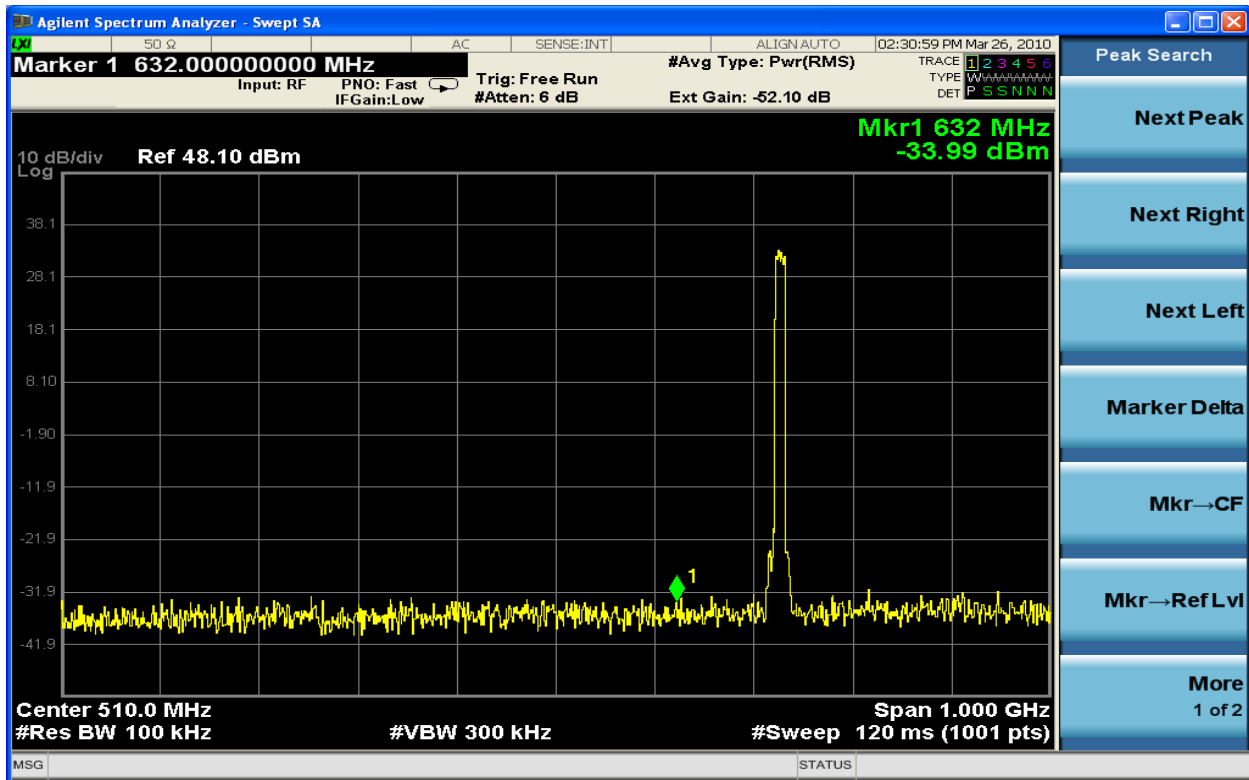

Figure 6-315 Spurious Emission TX1 QPSK 737MHz – 10MHz (10MHz-1.1GHz)

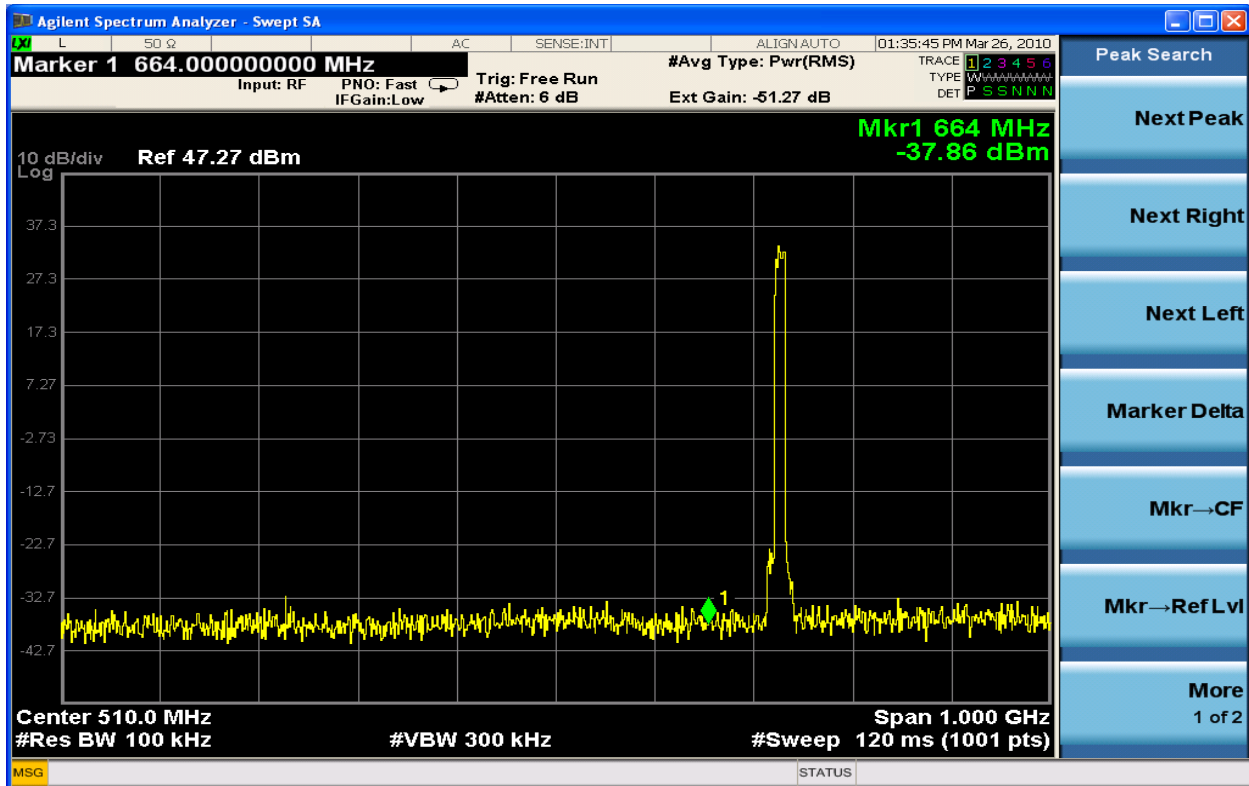

Figure 6-316 Spurious Emission TX2 QPSK 737MHz – 10MHz (10MHz-1.1GHz)

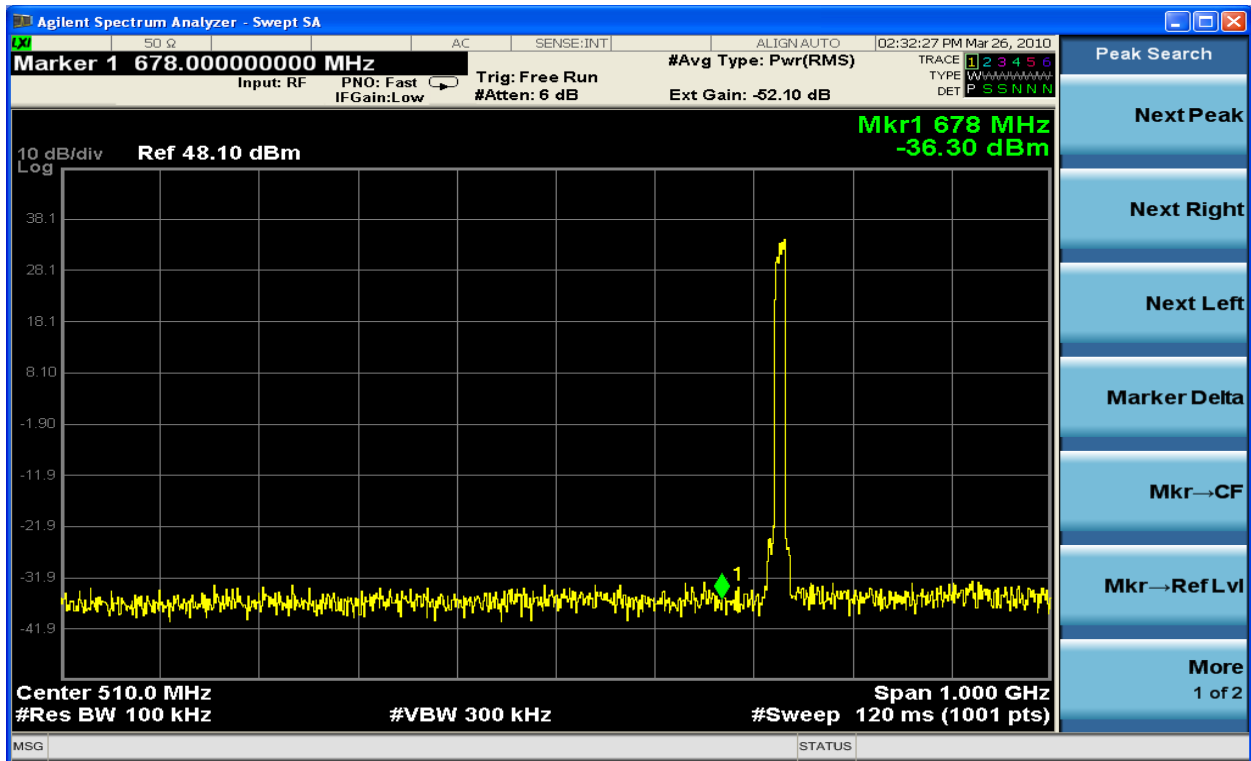

Figure 6-317 Spurious Emission TX1 16QAM 737MHz – 10MHz (10MHz-1.1GHz)

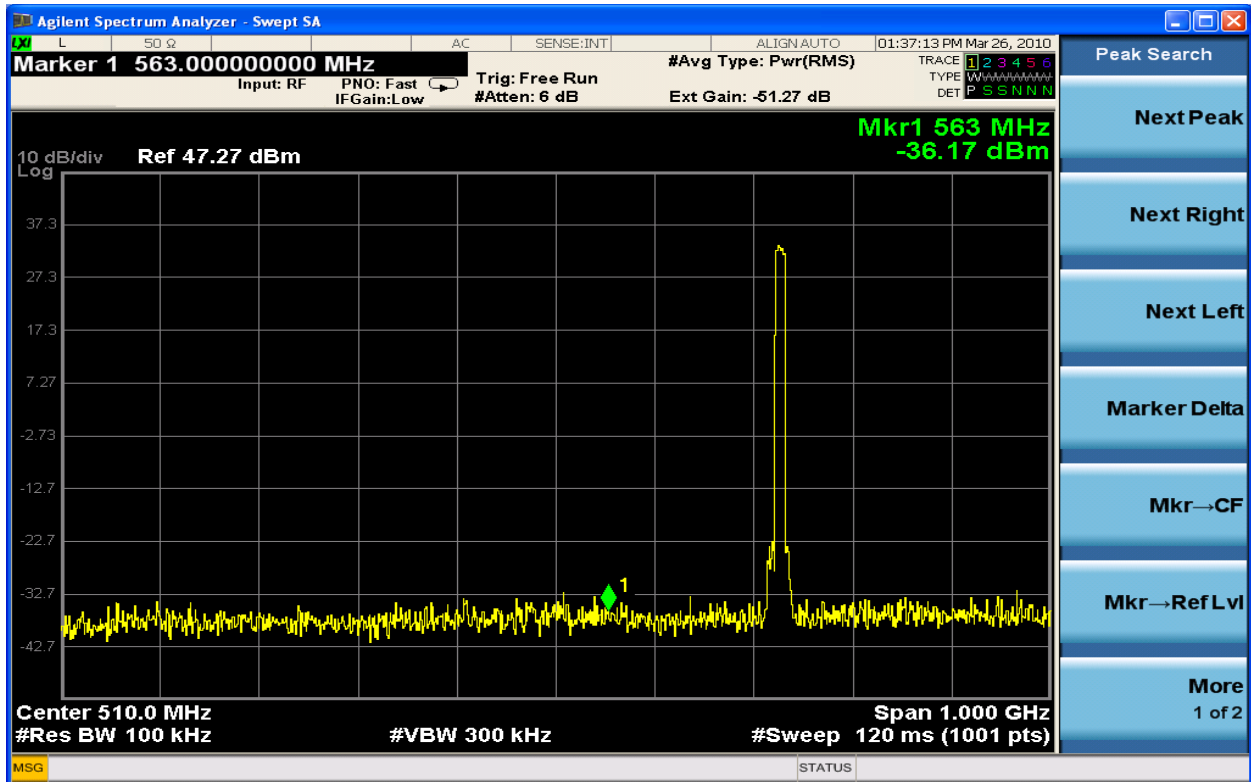

Figure 6-318 Spurious Emission TX2 16QAM 737MHz – 10MHz (10MHz-1.1GHz)

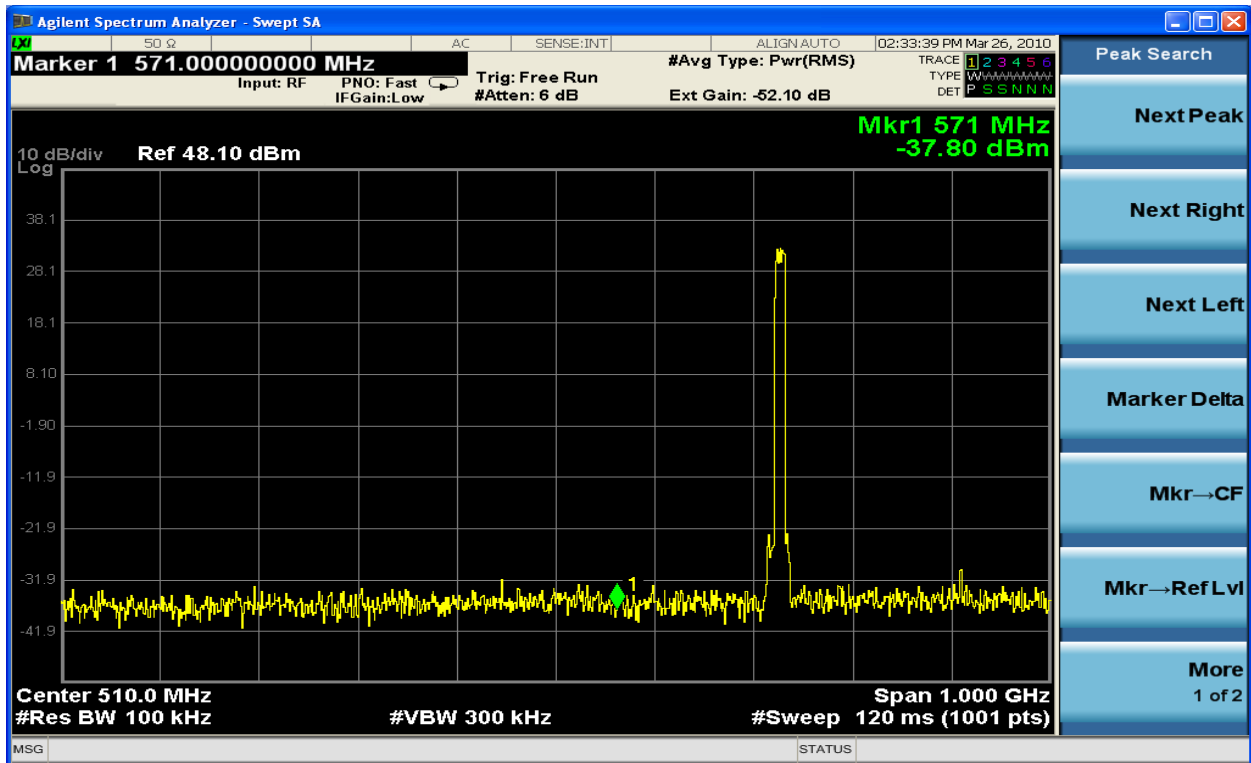

Figure 6-319 Spurious Emission TX1 64QAM 737MHz – 10MHz (10MHz-1.1GHz)

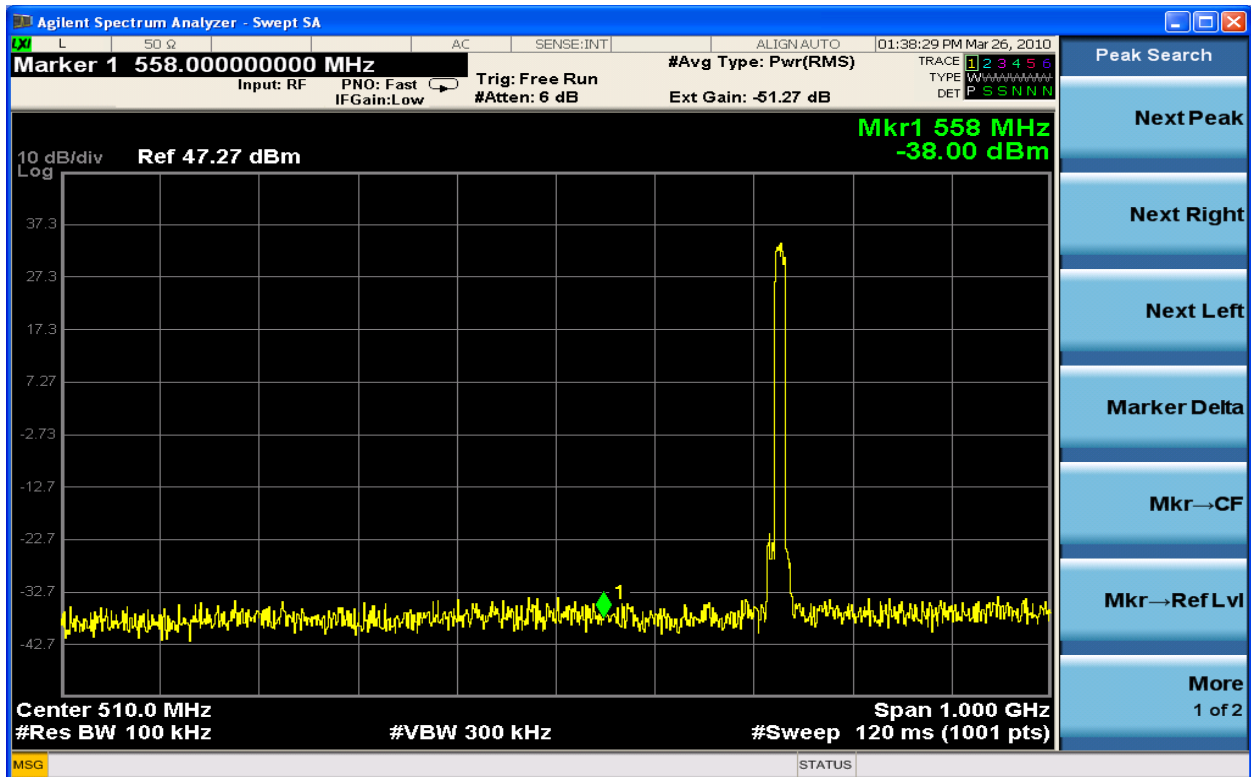

Figure 6-320 Spurious Emission TX2 64QAM 737MHz – 10MHz (10MHz-1.1GHz)

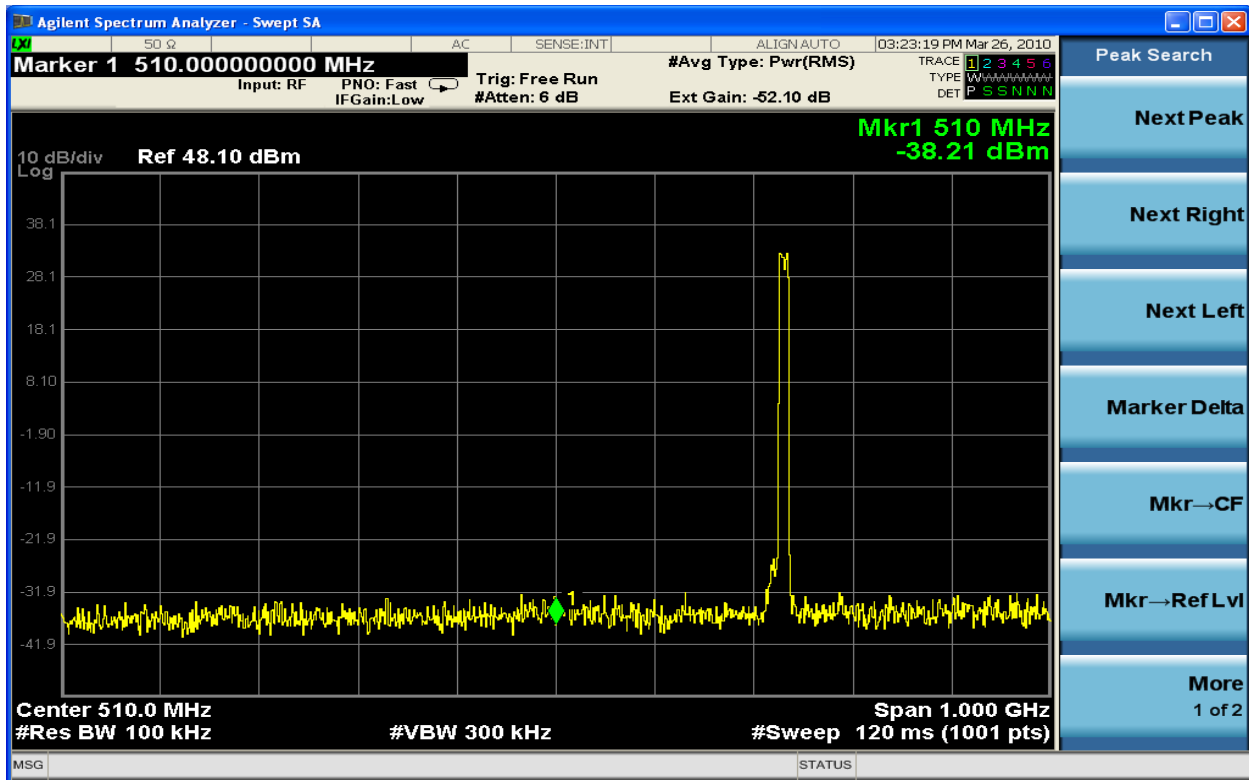

Figure 6-321 Spurious Emission TX1 QPSK 740.3MHz – 10MHz (10MHz-1.1GHz)

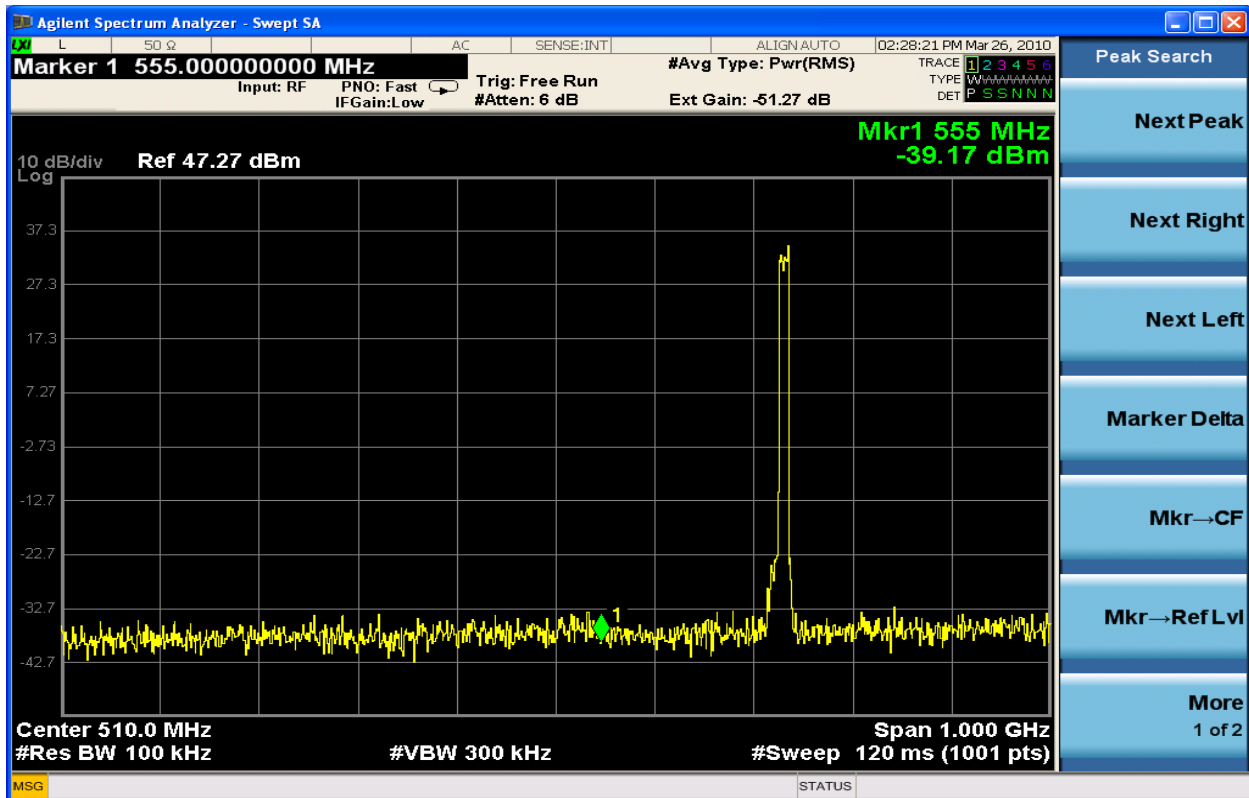

Figure 6-322 Spurious Emission TX2 QPSK 740.3MHz – 10MHz (10MHz-1.1GHz)

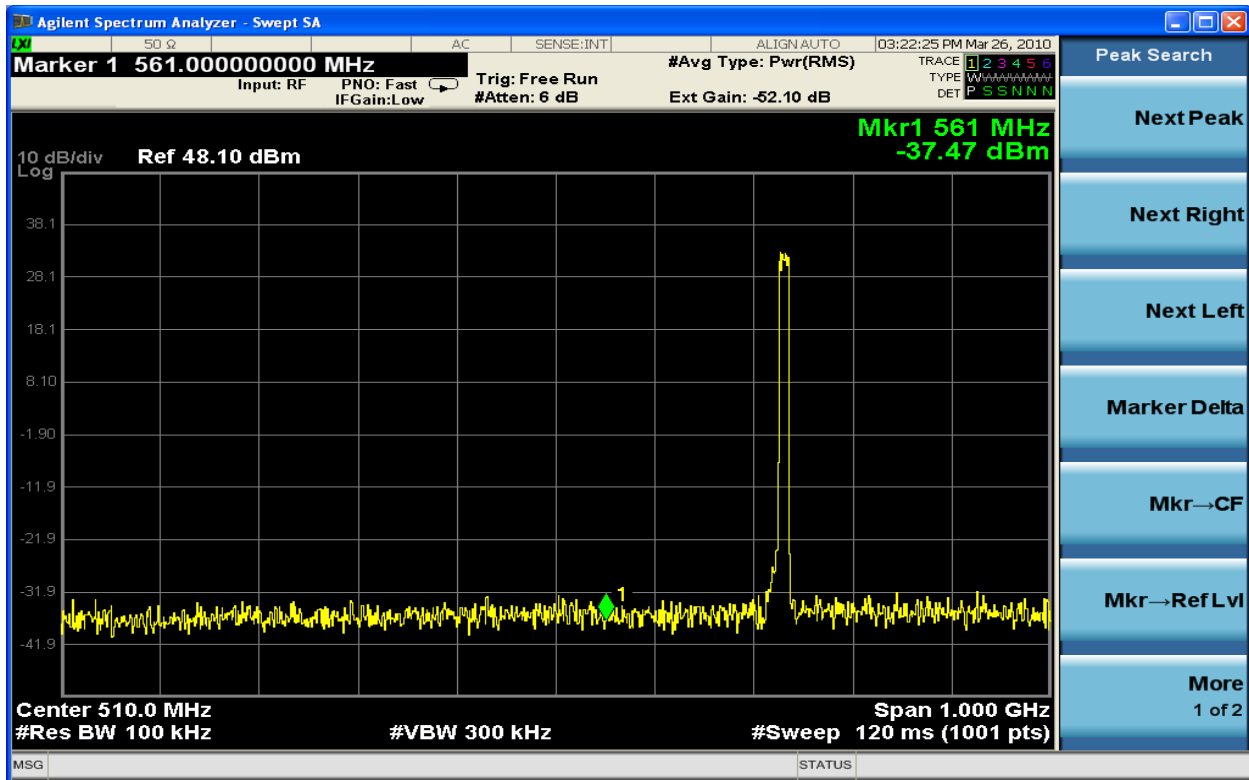

Figure 6-323 Spurious Emission TX1 16QAM 740.3MHz – 10MHz (10MHz-1.1GHz)

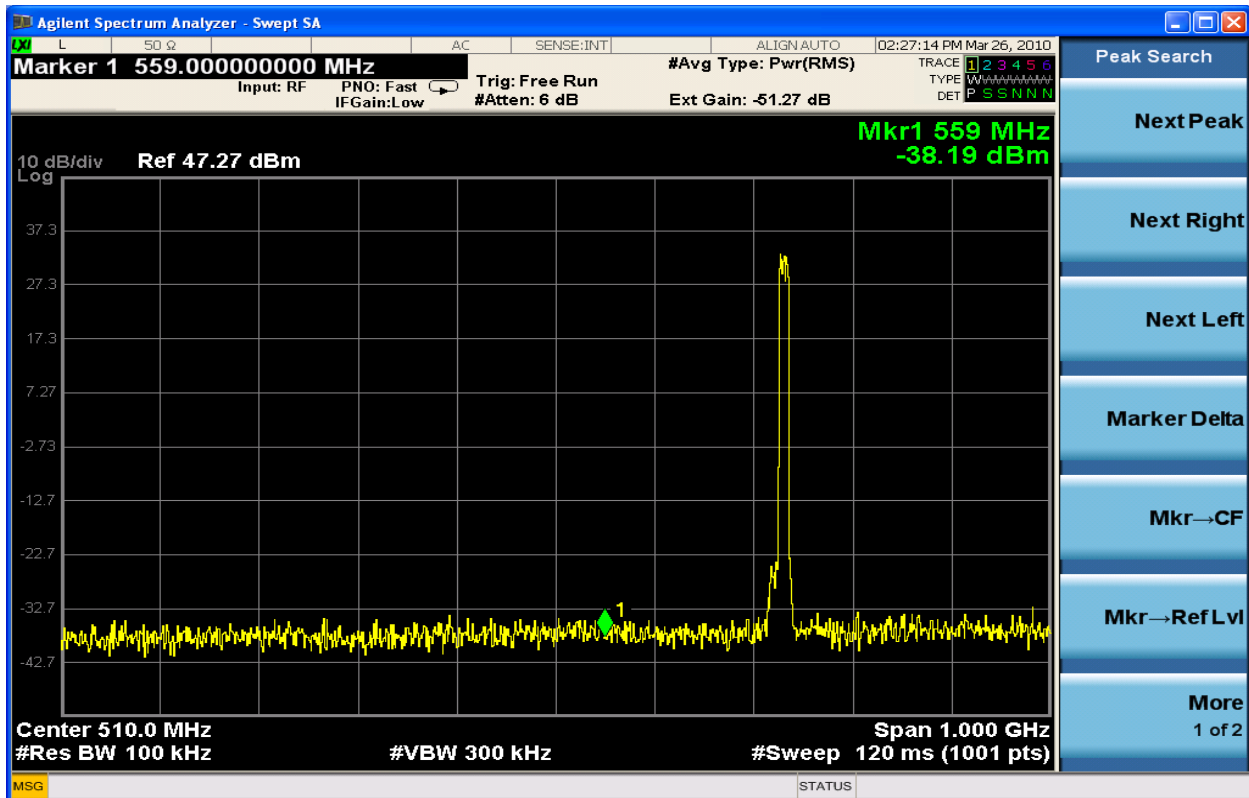

Figure 6-324 Spurious Emission TX2 16QAM 740.3MHz – 10MHz (10MHz-1.1GHz)

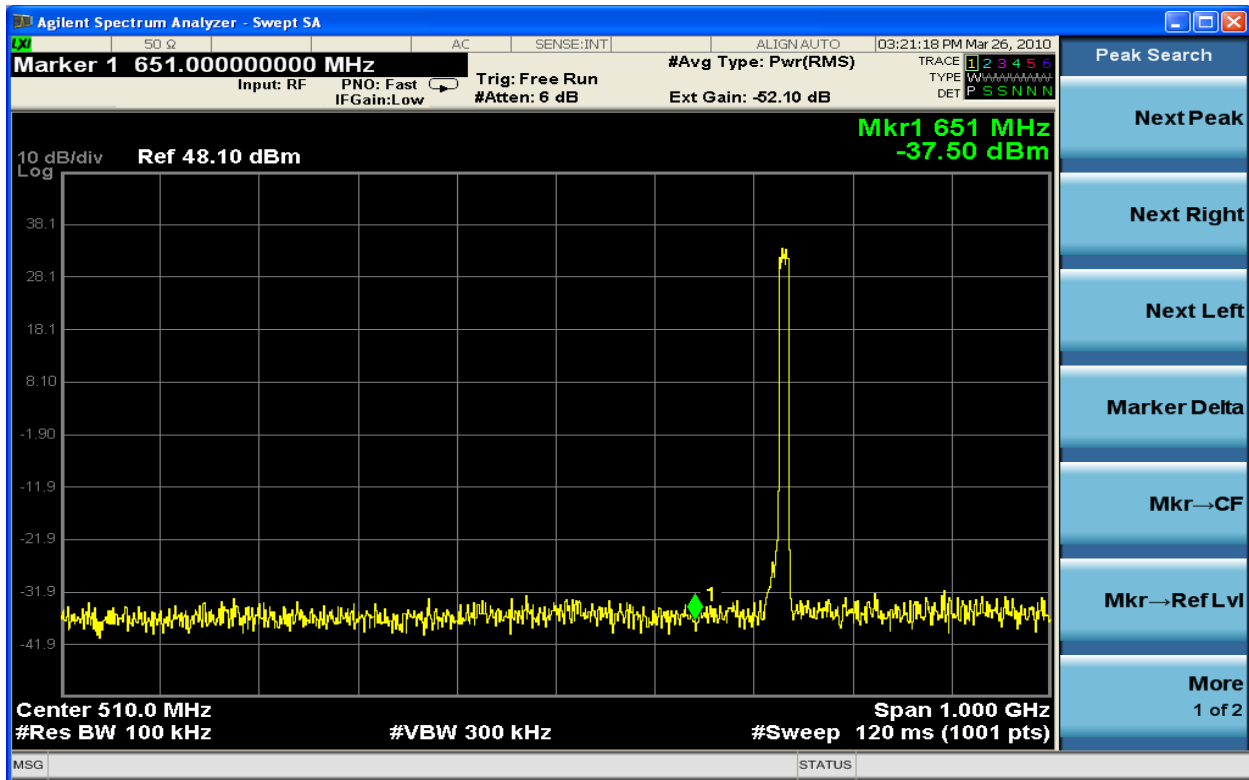

Figure 6-325 Spurious Emission TX1 64QAM 740.3MHz – 10MHz (10MHz-1.1GHz)

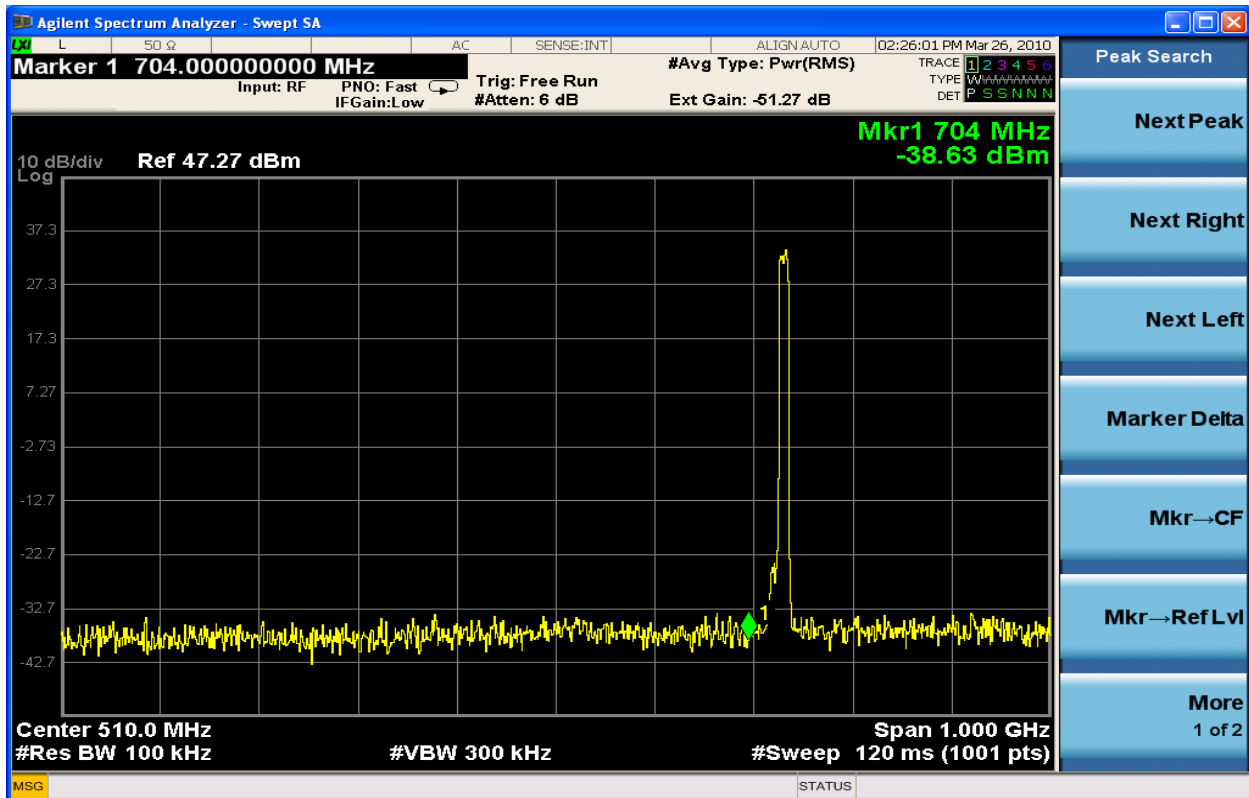

Figure 6-326 Spurious Emission TX2 64QAM 740.3MHz – 10MHz (10MHz-1.1GHz)

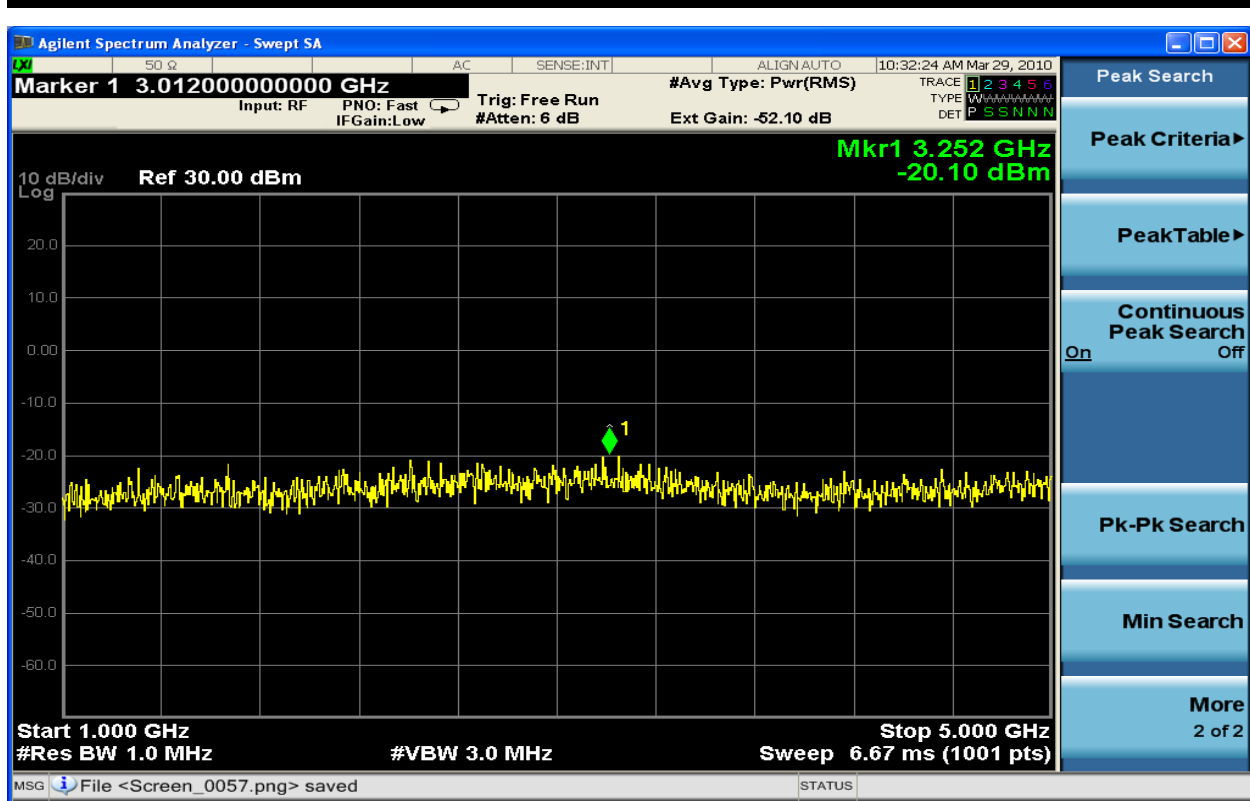

Figure 6-327 Spurious Emission TX1 QPSK 733.7MHz – 10MHz (1 GHz - 5GHz)

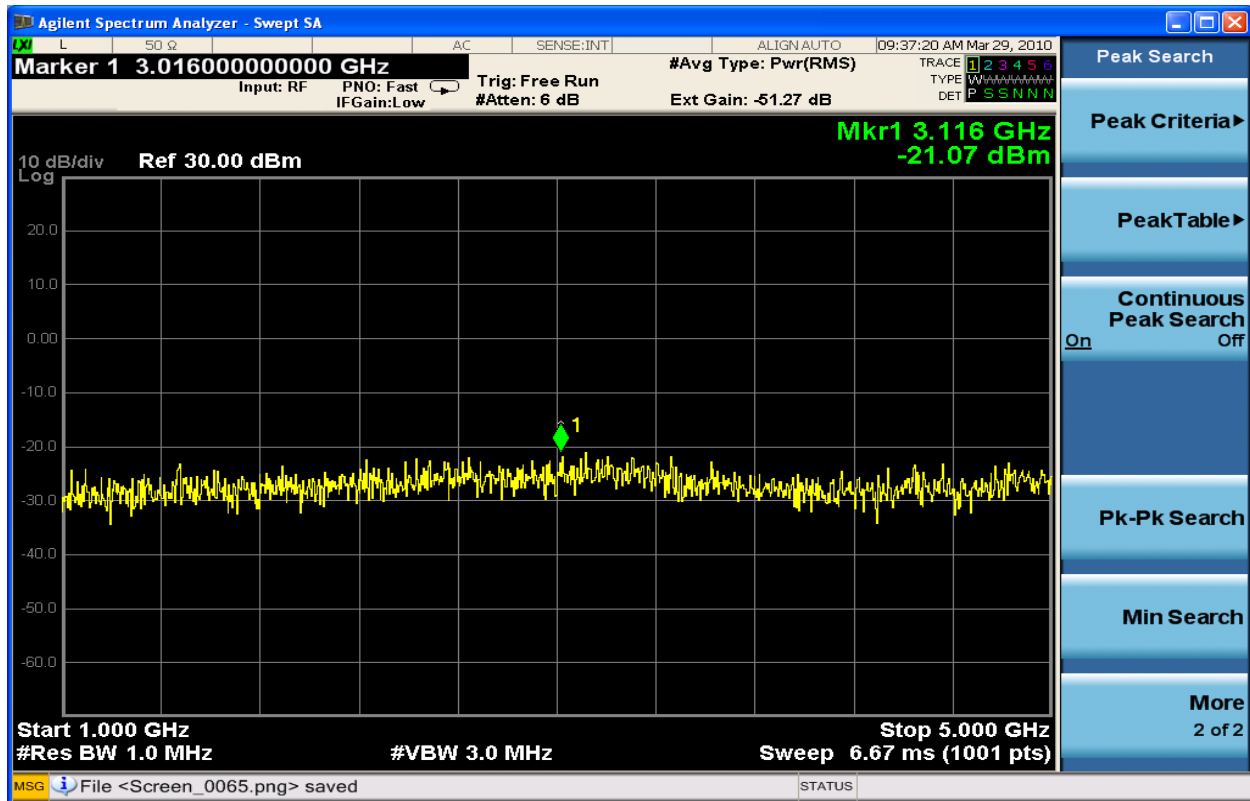

Figure 6-328 Spurious Emission TX2 QPSK 733.7MHz – 10MHz (1 GHz - 5GHz)

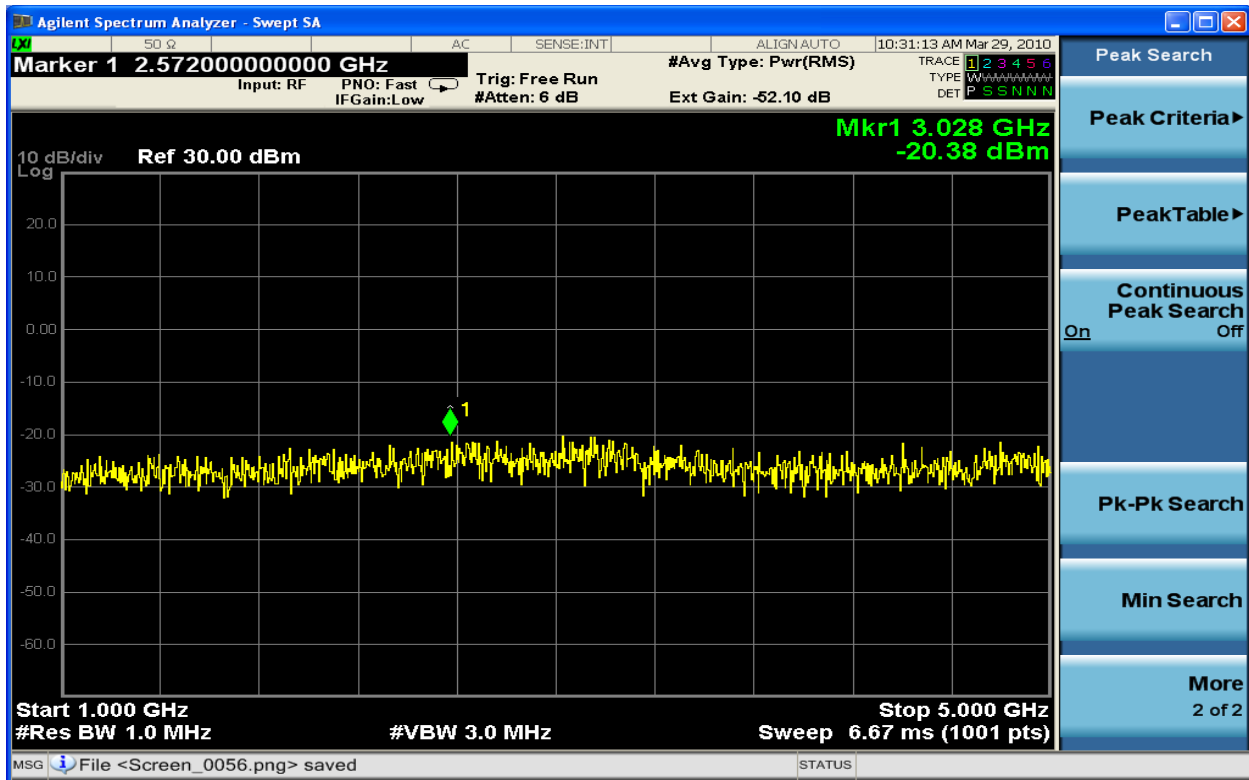

Figure 6-329 Spurious Emission TX1 16QAM 733.7MHz – 10MHz (1 GHz - 5GHz)

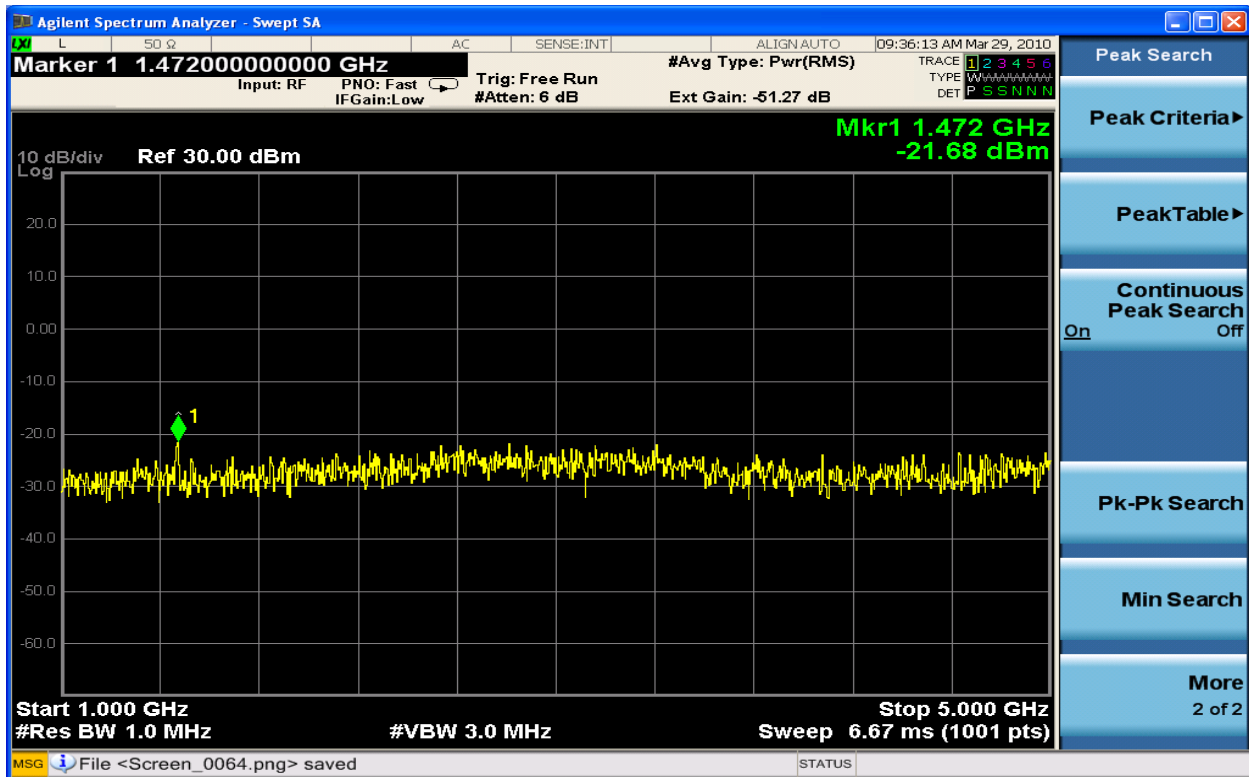

Figure 6-330 Spurious Emission TX2 16QAM 733.7MHz – 10MHz (1 GHz - 5GHz)

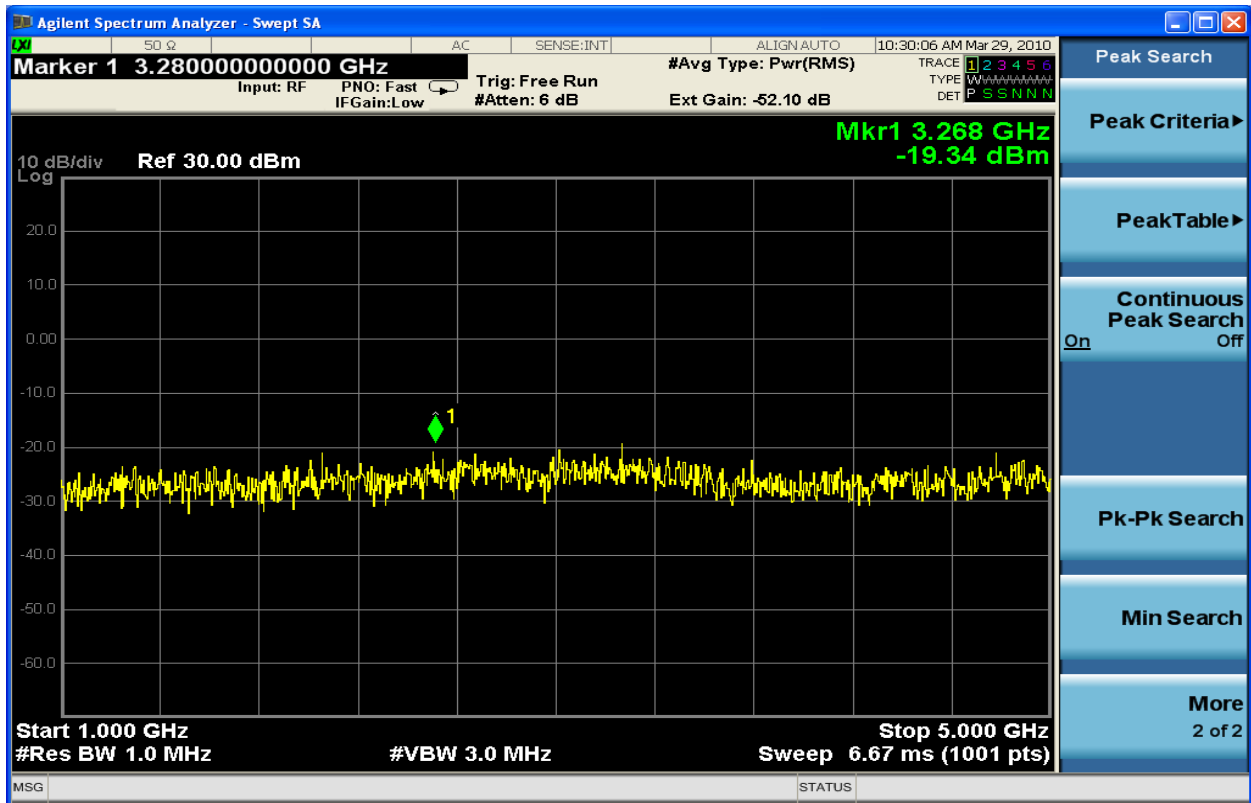

Figure 6-331 Spurious Emission TX1 64QAM 733.7MHz – 10MHz (1 GHz - 5GHz)

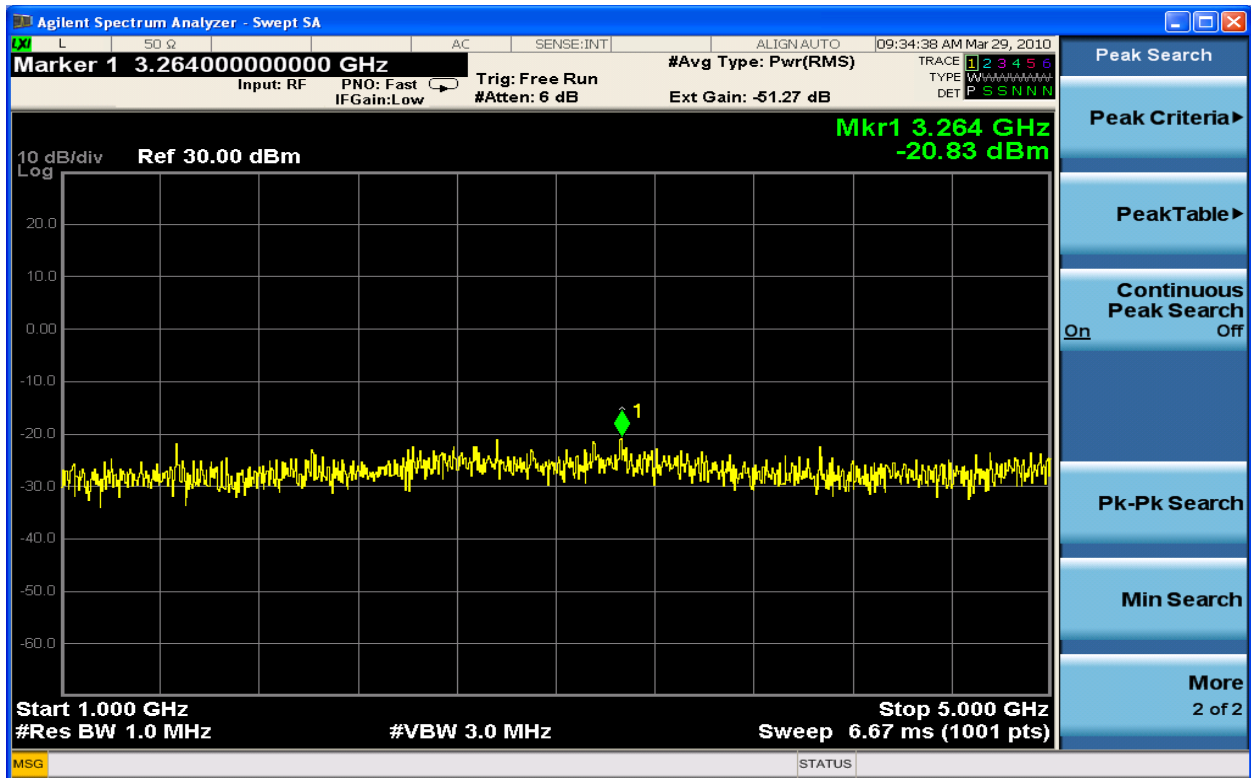

Figure 6-332 Spurious Emission TX2 64QAM 733.7MHz – 10MHz (1 GHz - 5GHz)

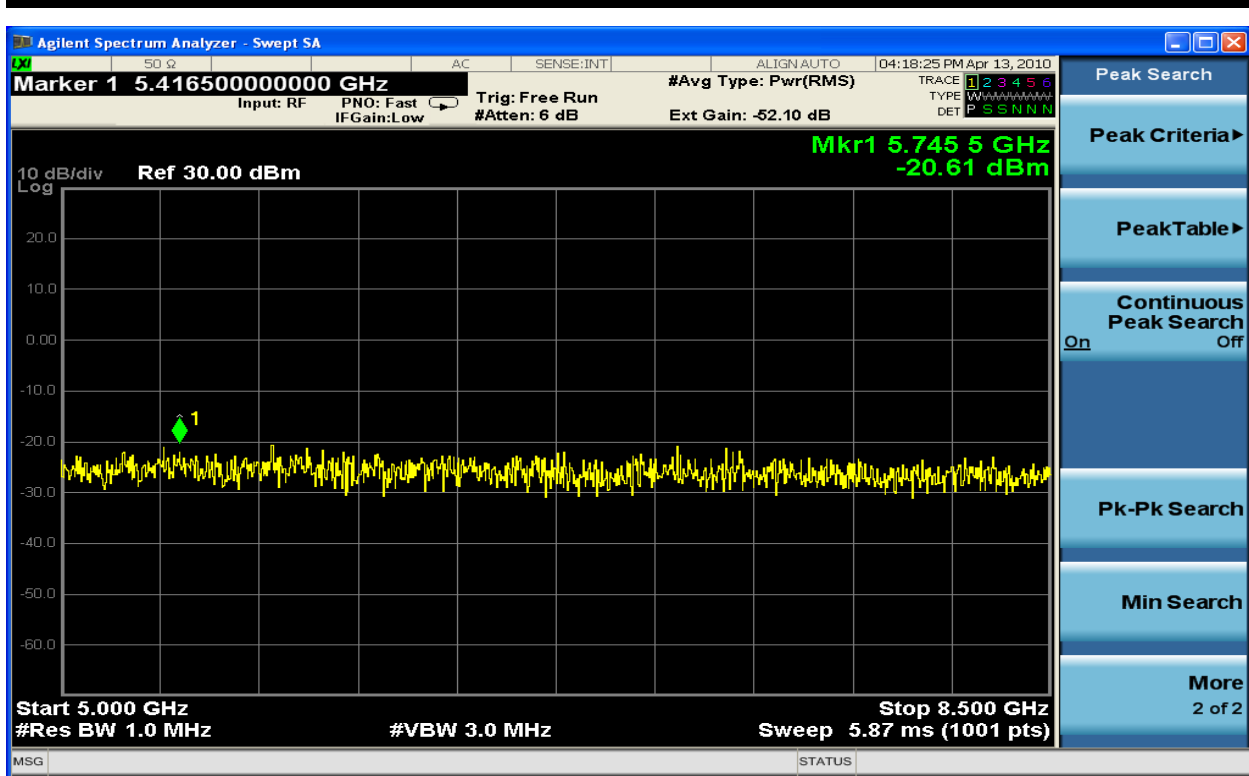

Figure 6-333 Spurious Emission TX1 QPSK 733.7MHz – 10MHz (5 GHz - 8GHz)

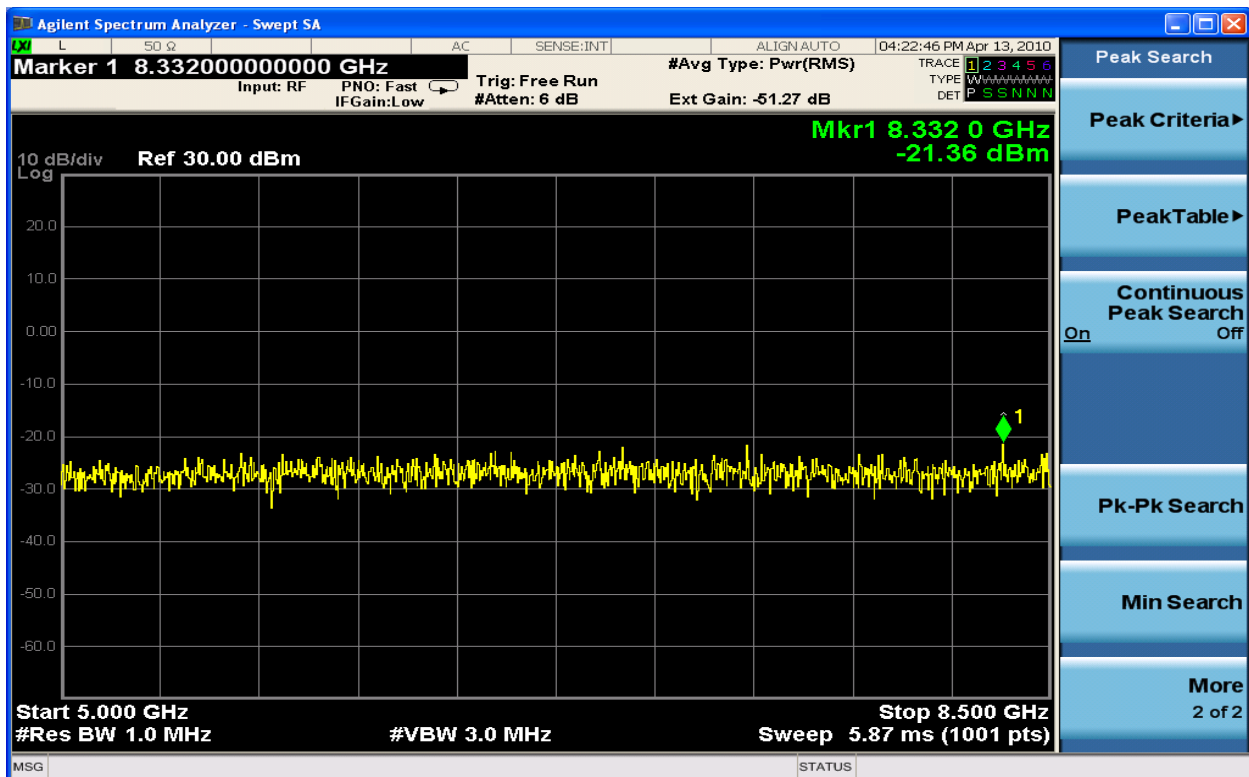

Figure 6-334 Spurious Emission TX2 QPSK 733.7MHz – 10MHz (5 GHz - 8GHz)

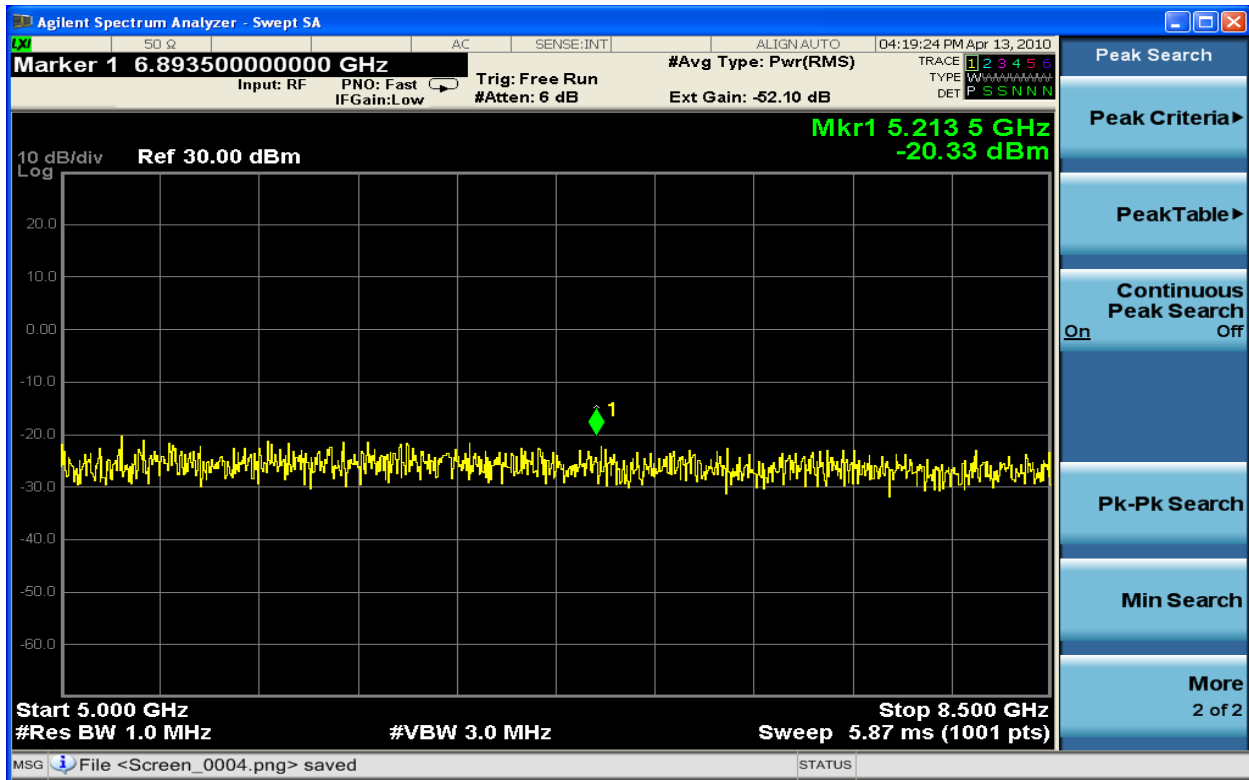

Figure 6-335 Spurious Emission TX1 16QAM 733.7MHz – 10MHz (5 GHz - 8GHz)

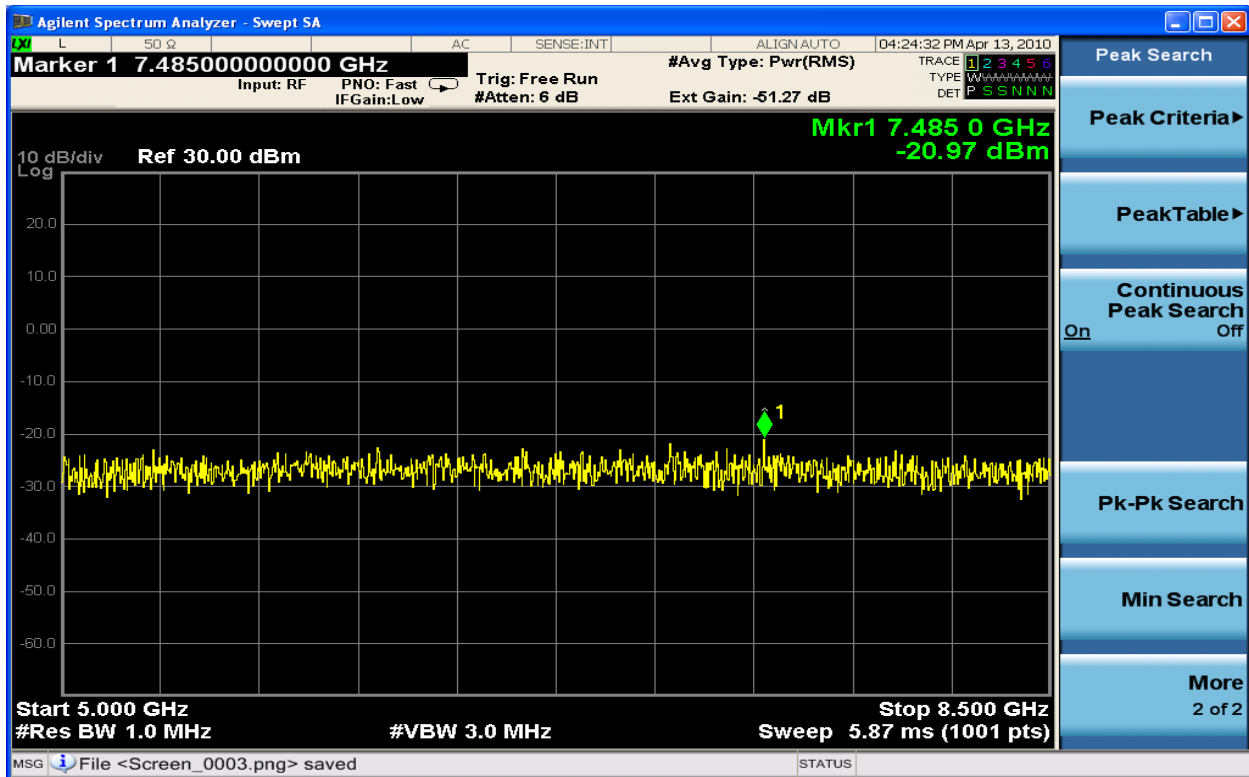

Figure 6-336 Spurious Emission TX2 16QAM 733.7MHz – 10MHz (5 GHz - 8GHz)

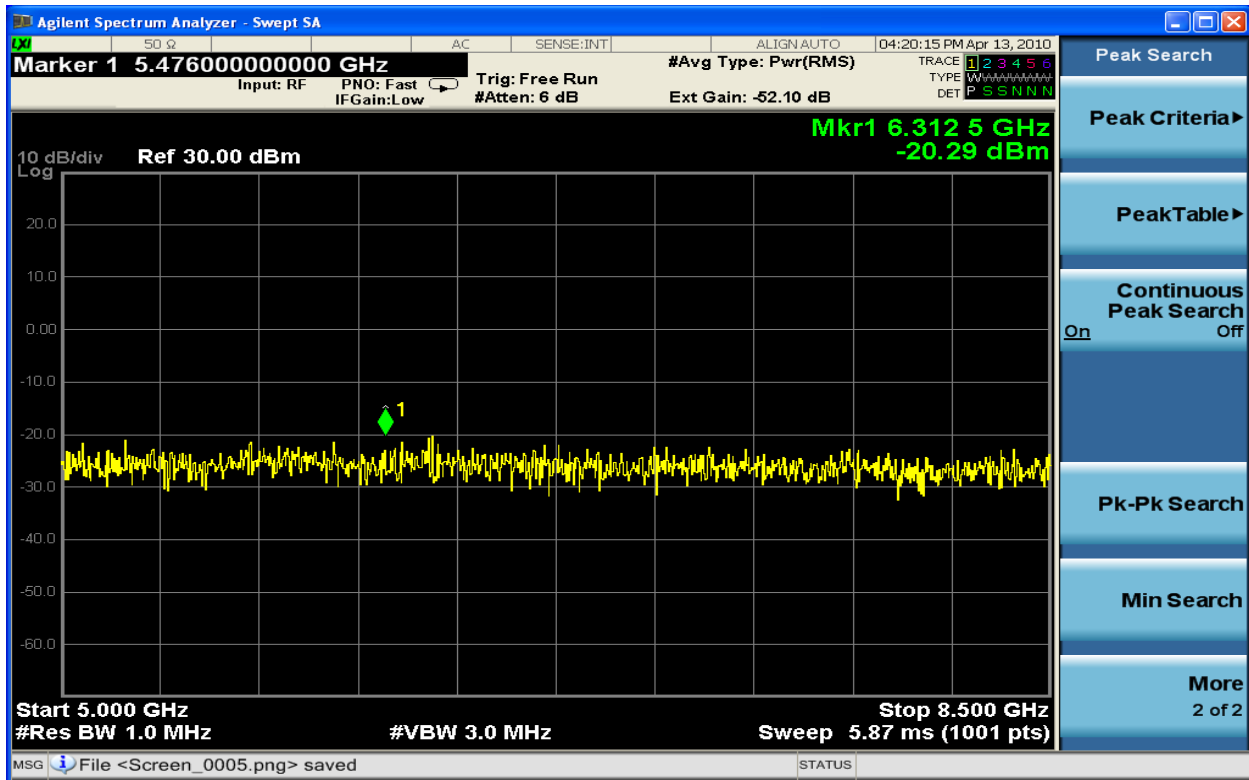

Figure 6-337 Spurious Emission TX1 64QAM 733.7MHz – 10MHz (5 GHz - 8GHz)

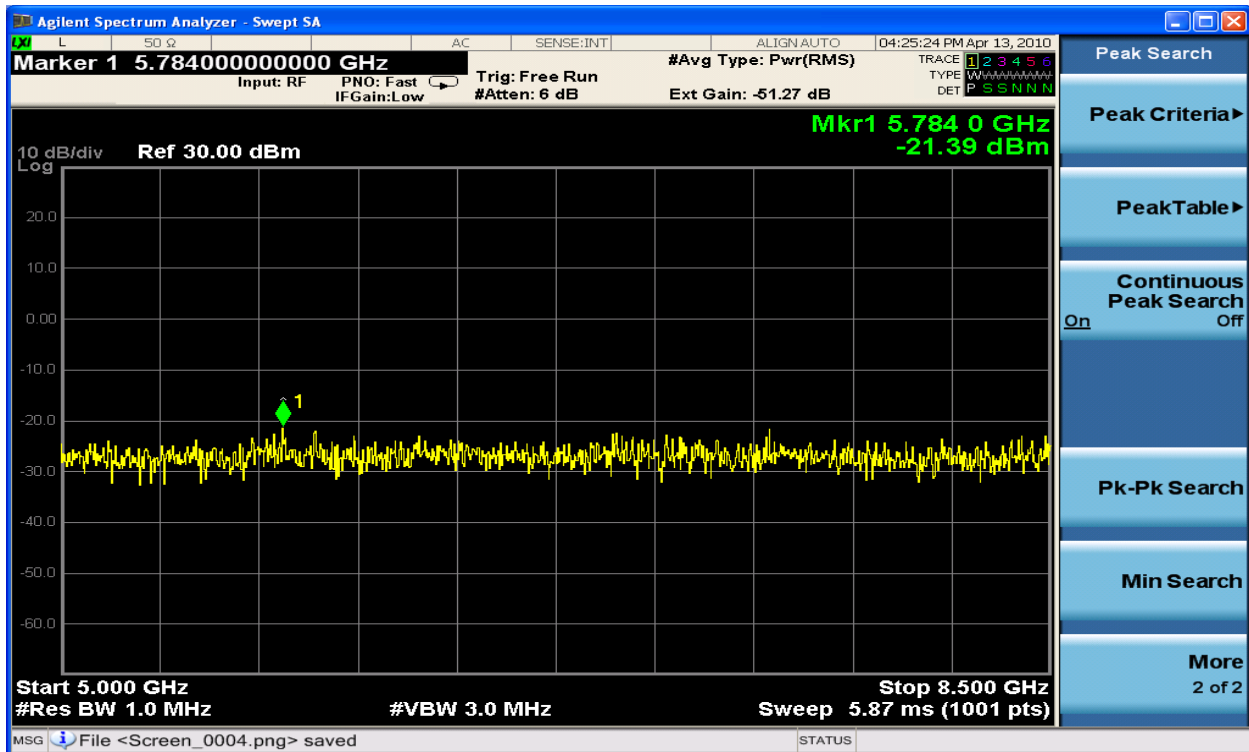

Figure 6-338 Spurious Emission TX2 64QAM 733.7MHz – 10MHz (5 GHz - 8GHz)

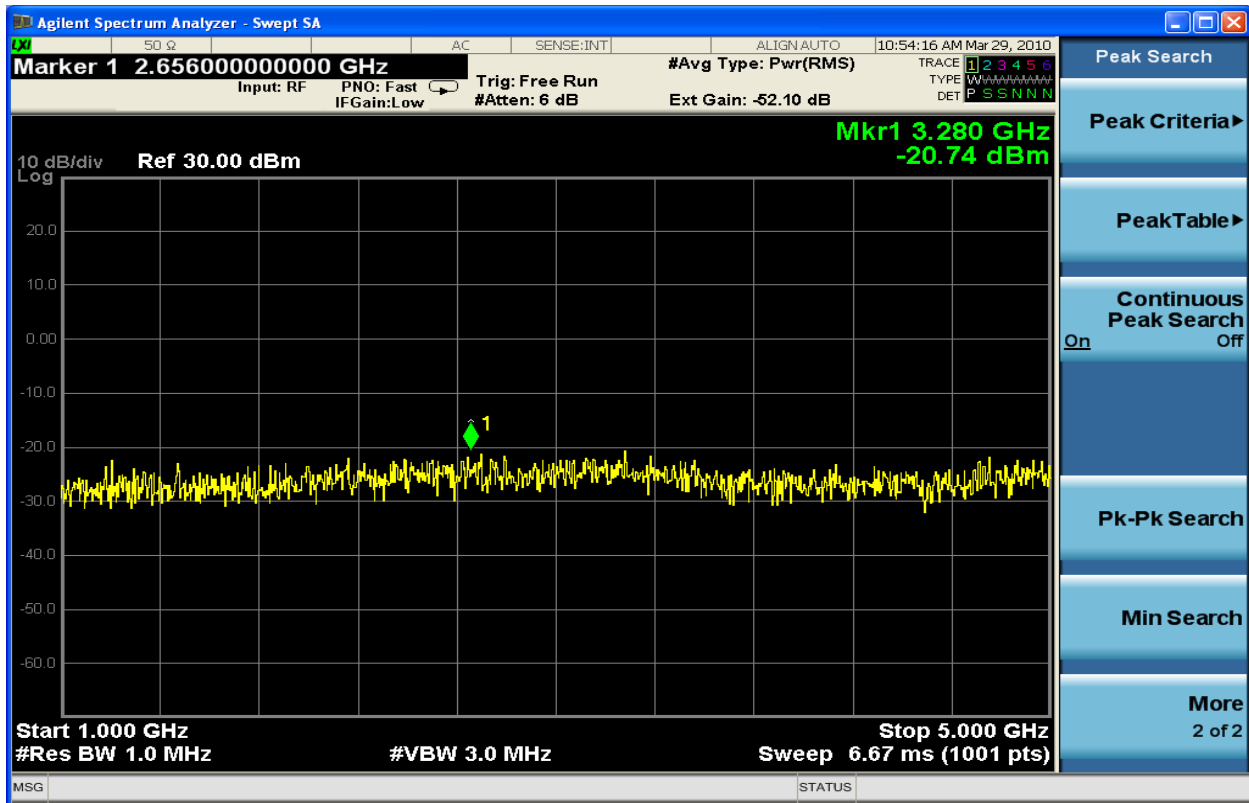

Figure 6-339 Spurious Emission TX1 QPSK 737MHz – 10MHz (1GHz - 5GHz)

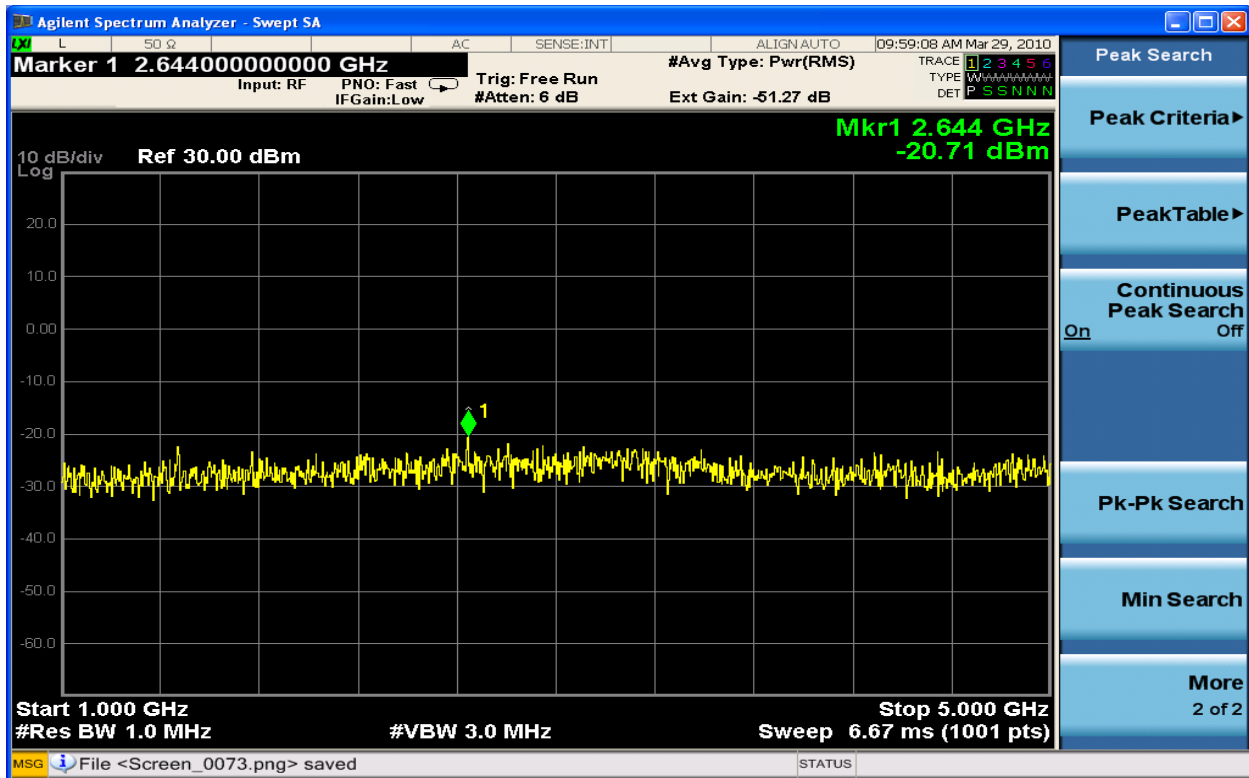

Figure 6-340 Spurious Emission TX2 QPSK 737MHz – 10MHz (1GHz - 5GHz)

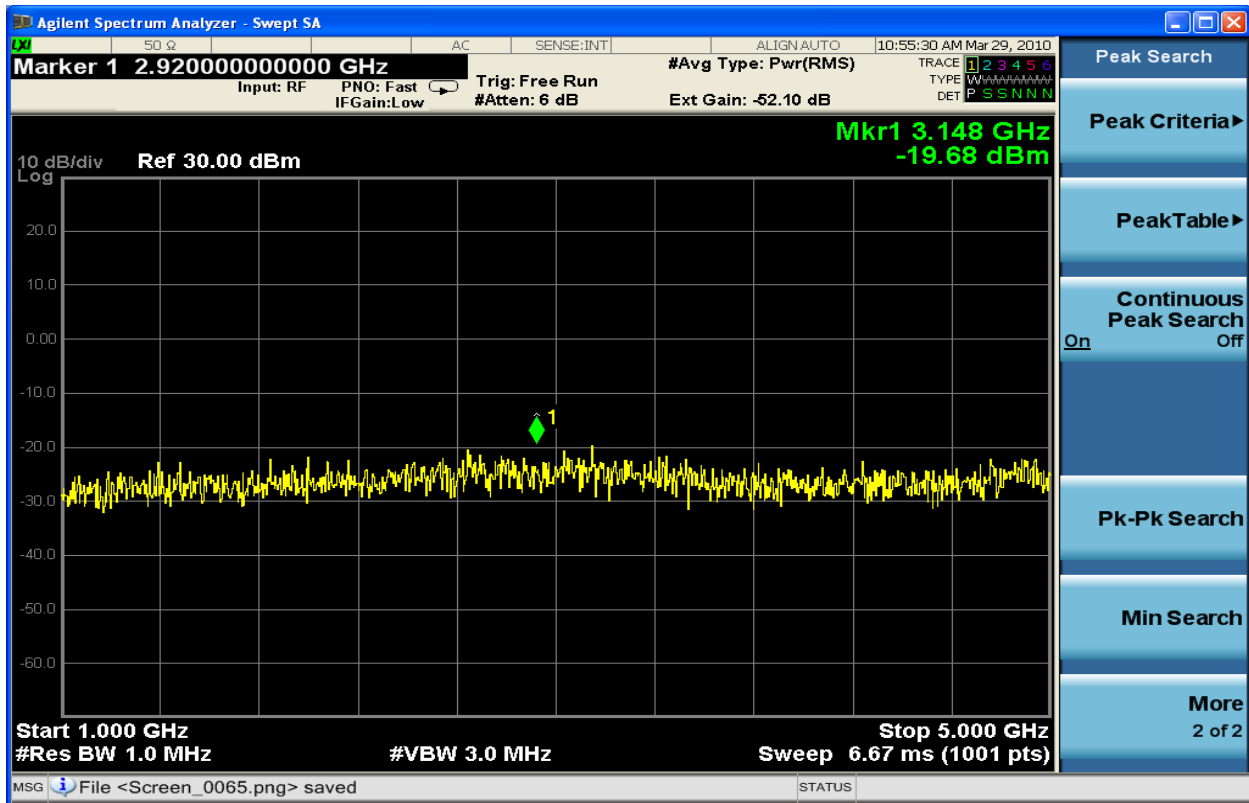

Figure 6-341 Spurious Emission TX1 16QAM 737MHz – 10MHz (1GHz - 5GHz)

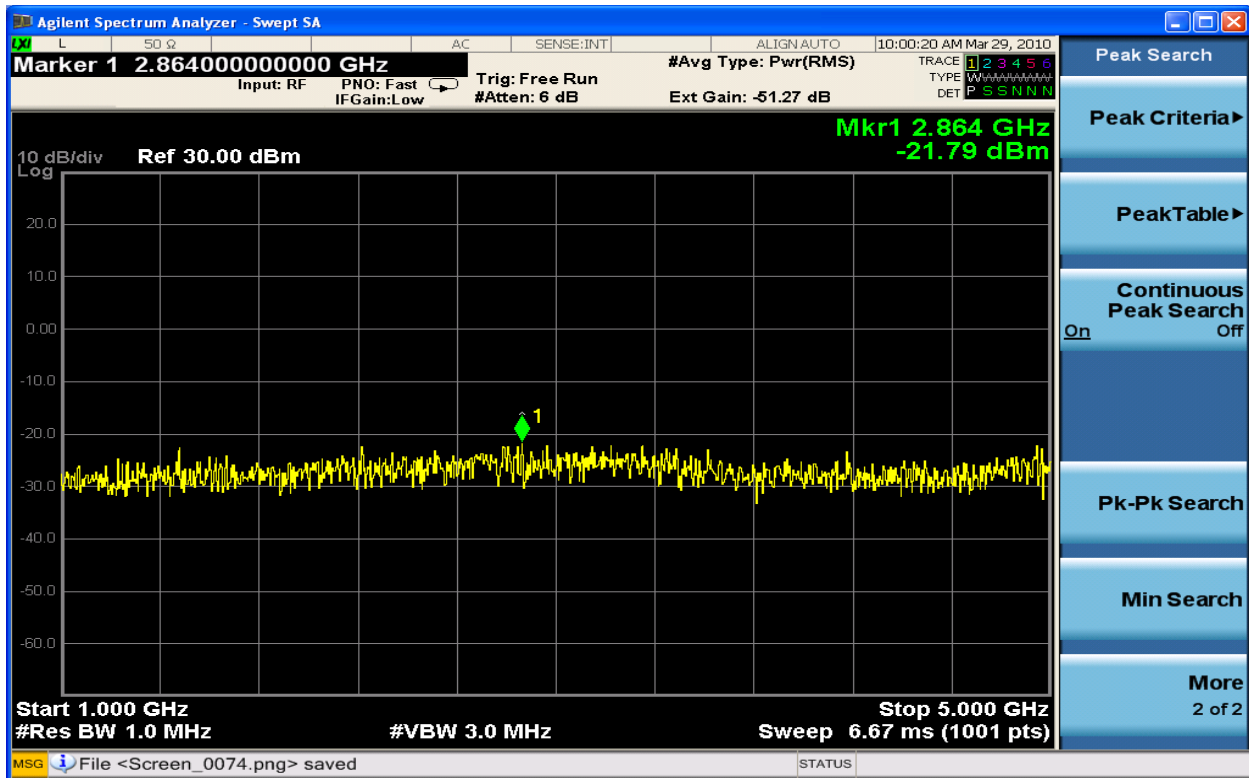

Figure 6-342 Spurious Emission TX2 16QAM 737MHz – 10MHz (1GHz - 5GHz)

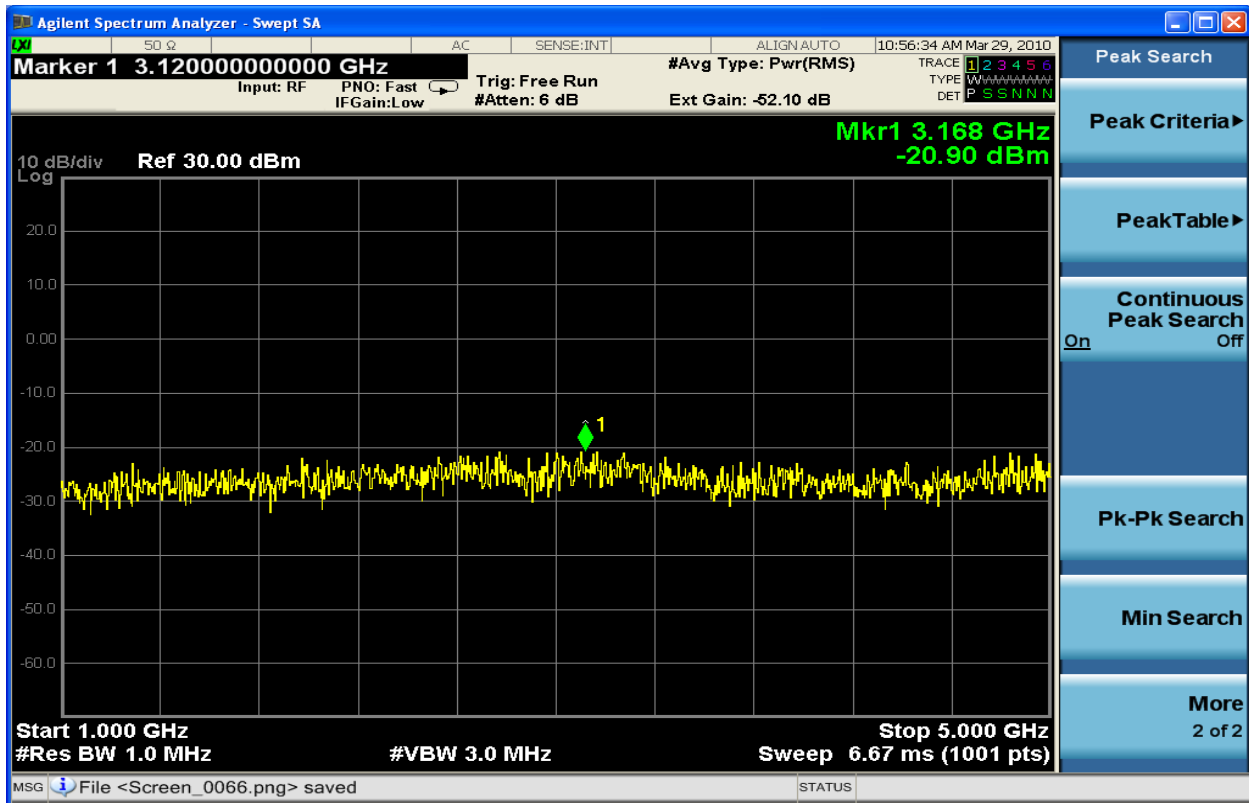

Figure 6-343 Spurious Emission TX1 64QAM 737MHz – 10MHz (1GHz - 5GHz)

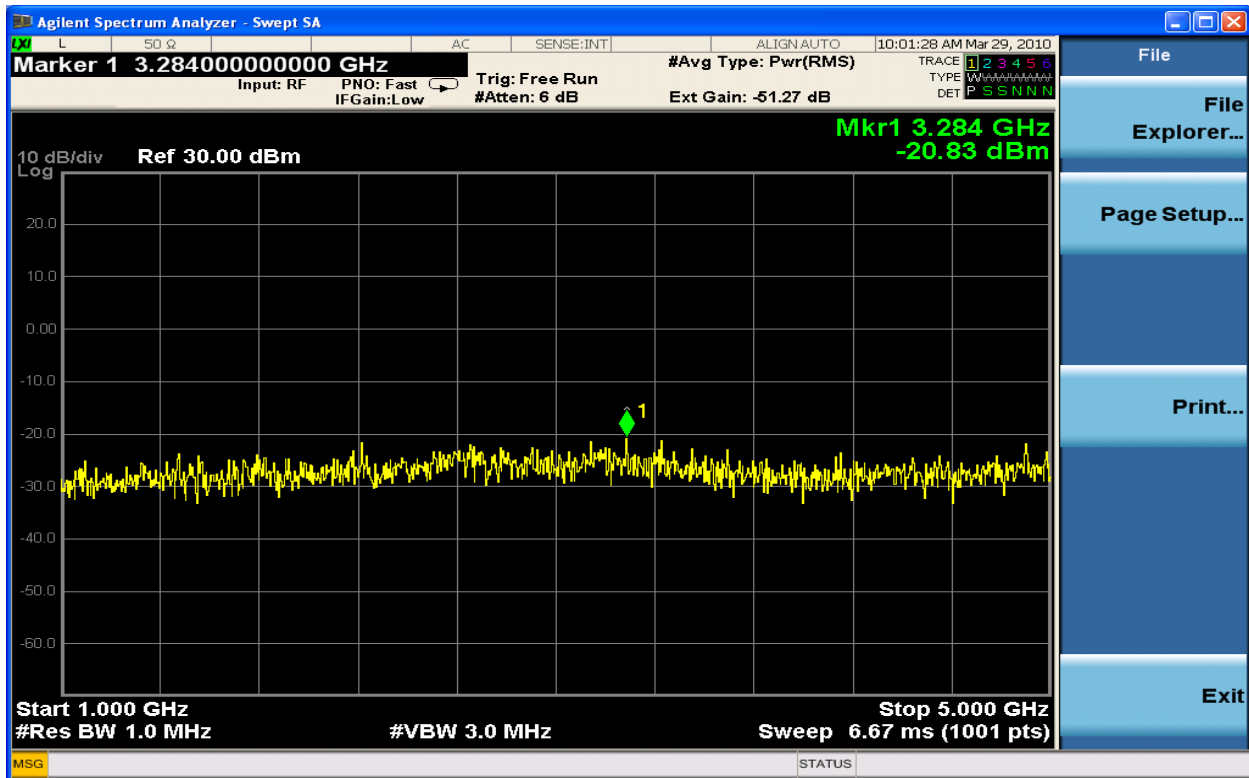

Figure 6-344 Spurious Emission TX2 64QAM 737MHz – 10MHz (1GHz - 5GHz)

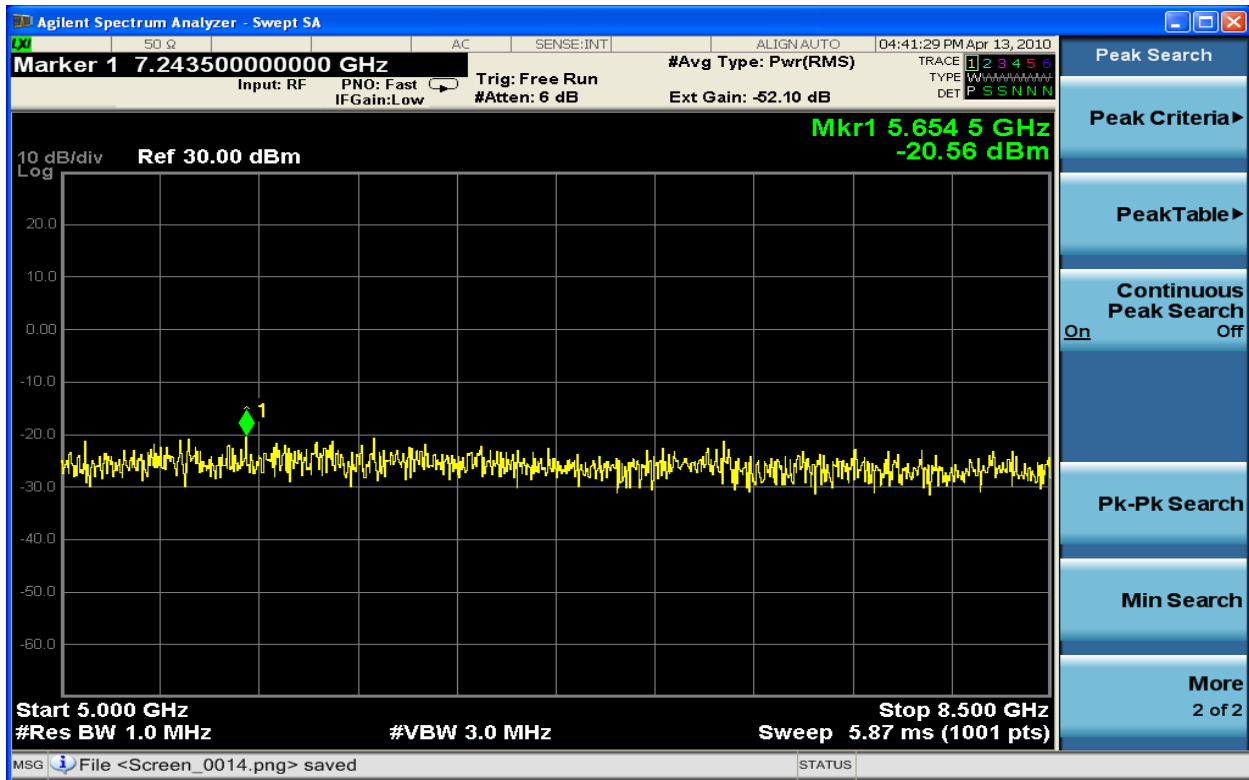

Figure 6-345 Spurious Emission TX1 QPSK 737MHz – 10MHz (5GHz - 8GHz)

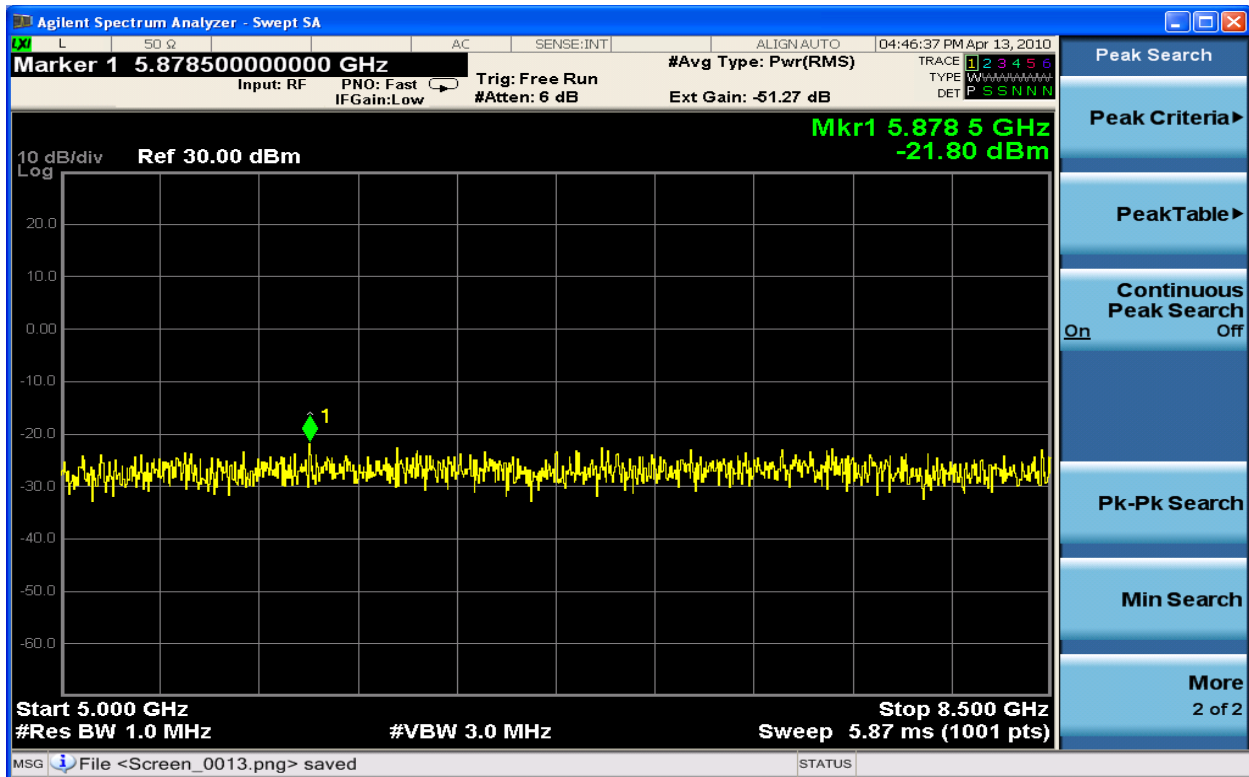

Figure 6-346 Spurious Emission TX2 QPSK 737MHz – 10MHz (5GHz - 8GHz)

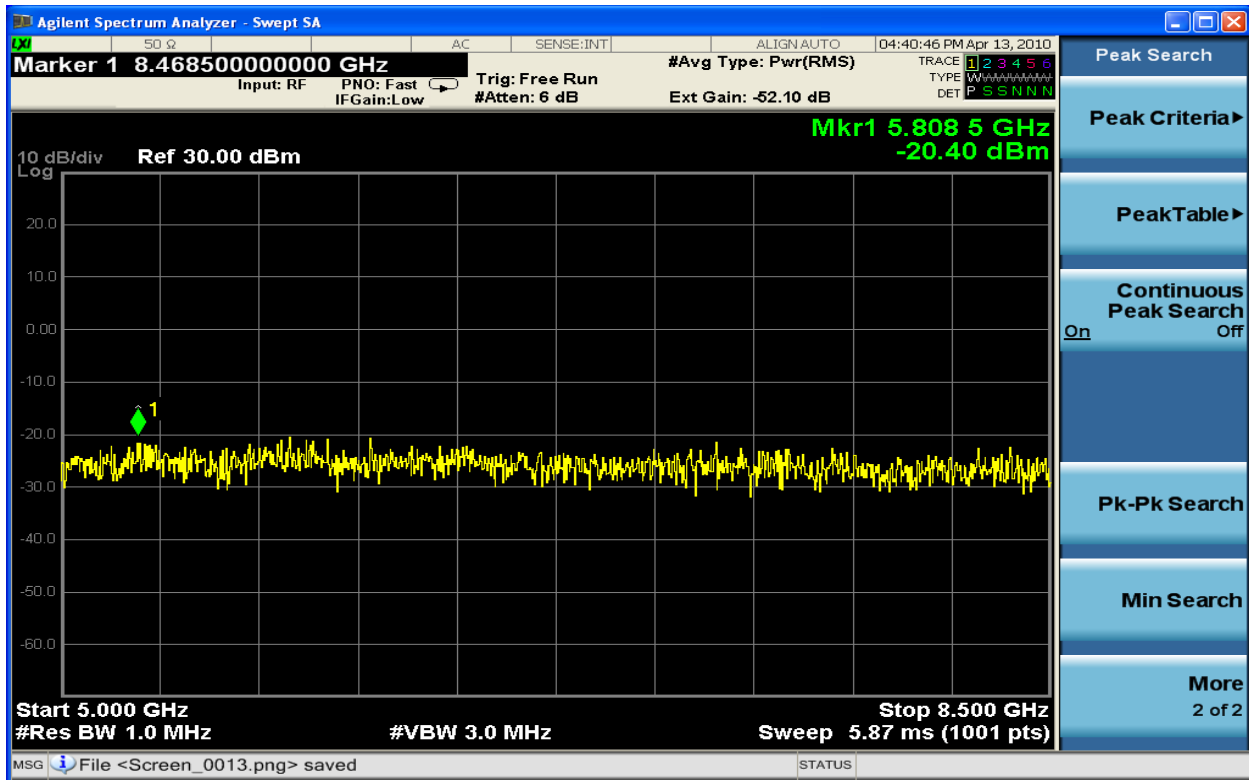

Figure 6-347 Spurious Emission TX1 16QAM 737MHz – 10MHz (5GHz - 8GHz)

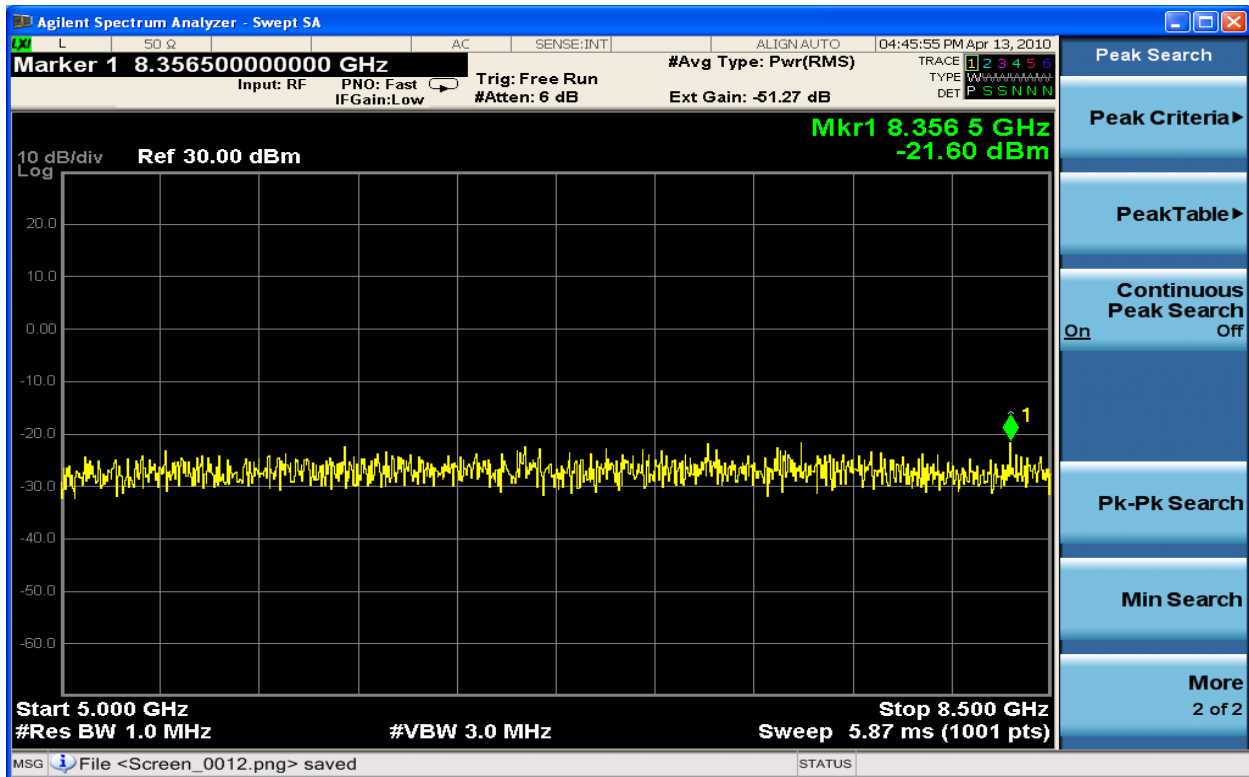

Figure 6-348 Spurious Emission TX2 16QAM 737MHz – 10MHz (5GHz - 8GHz)

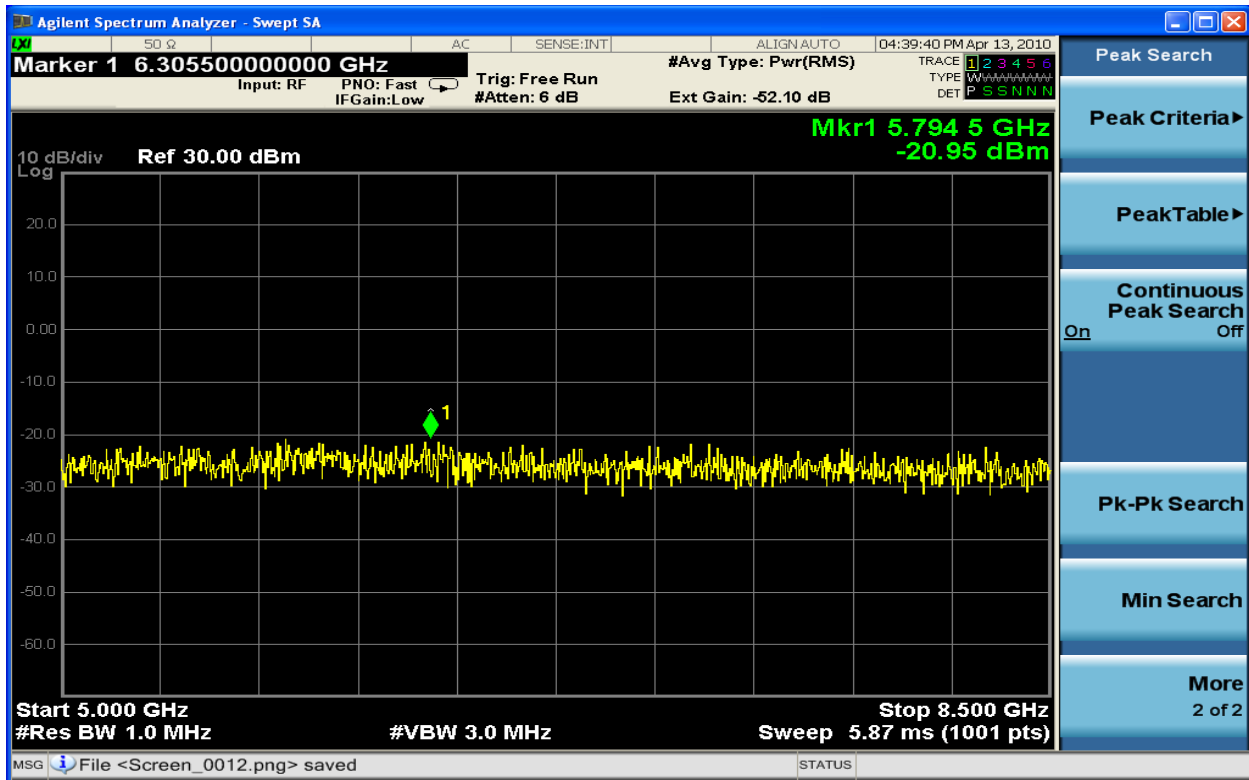

Figure 6-349 Spurious Emission TX1 64QAM 737MHz – 10MHz (5GHz - 8GHz)

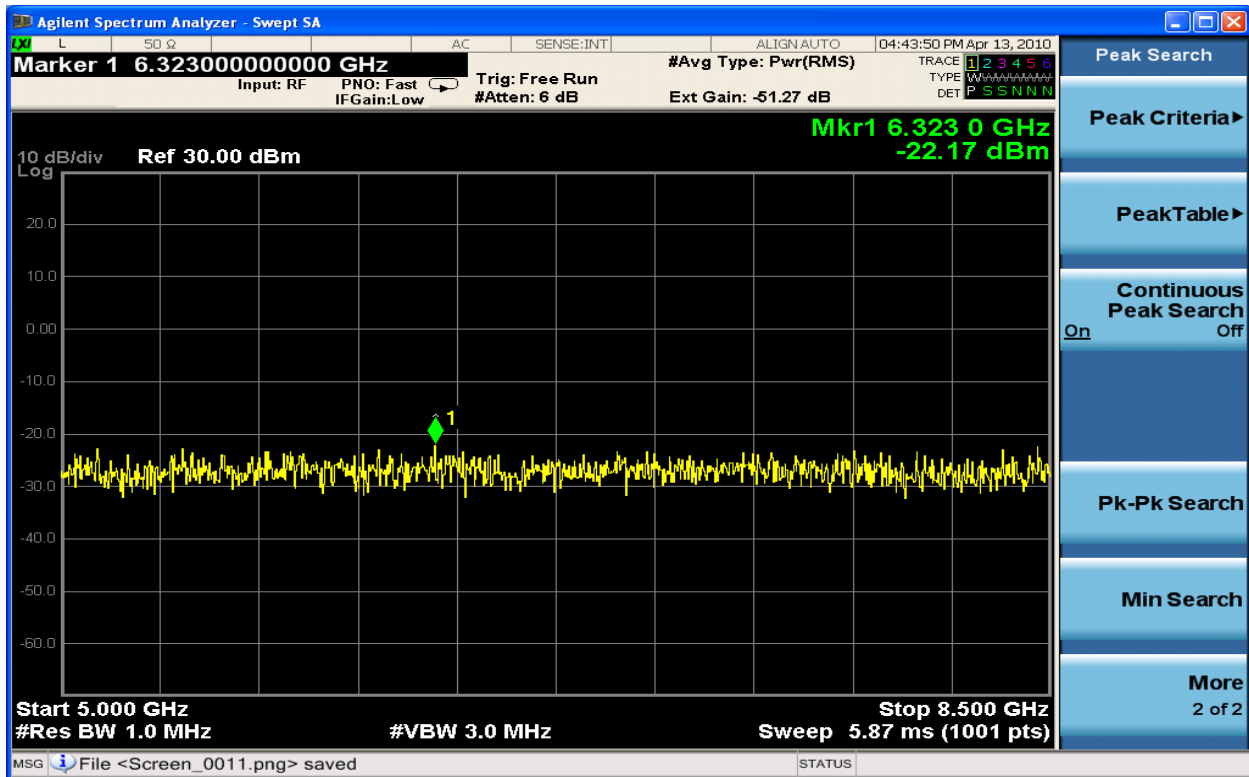

Figure 6-350 Spurious Emission TX2 64QAM 737MHz – 10MHz (5GHz - 8GHz)

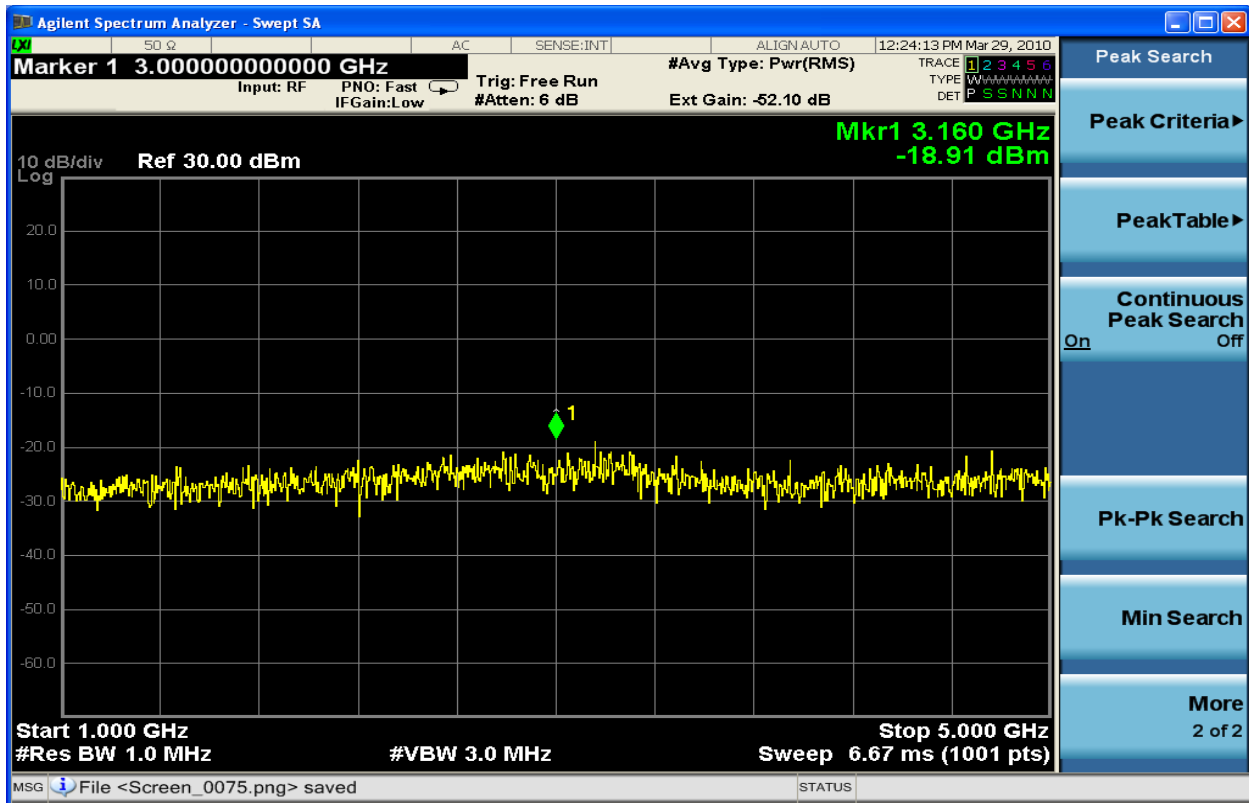

Figure 6-351 Spurious Emission TX1 QPSK 740.3MHz – 10MHz (1GHz - 5GHz)

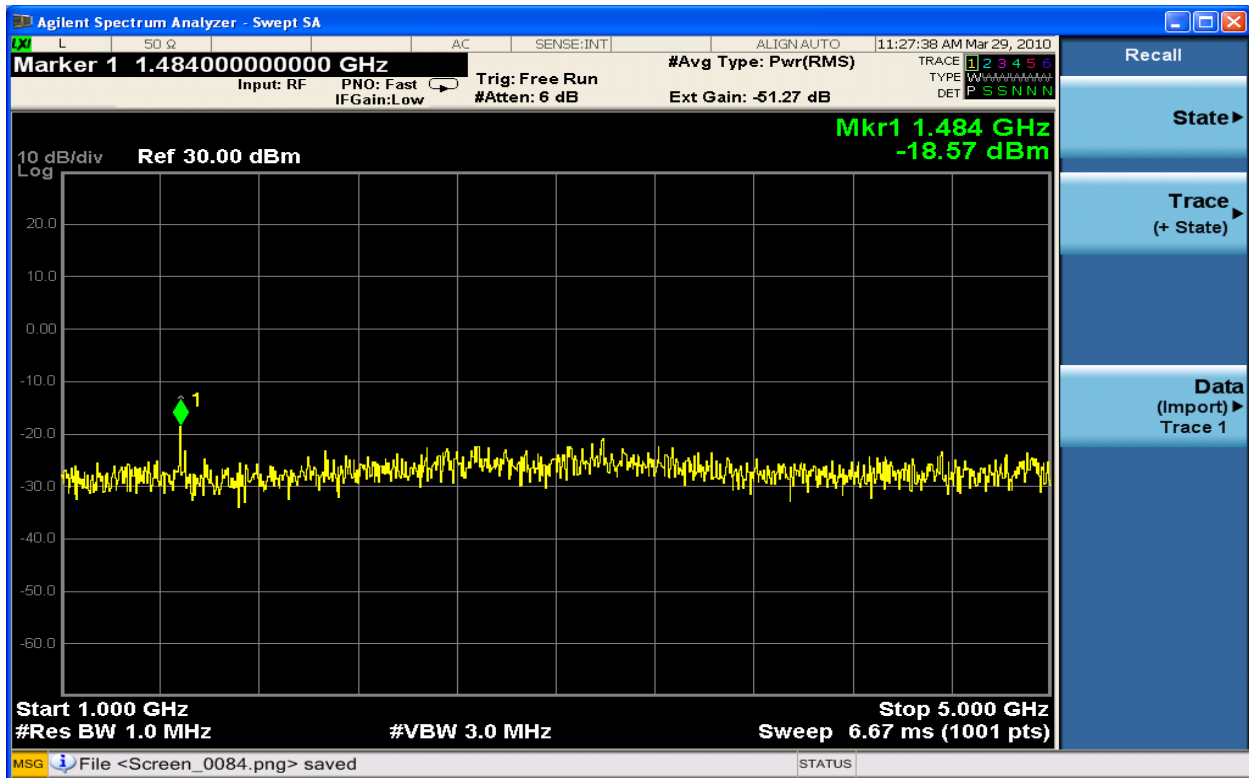

Figure 6-352 Spurious Emission TX2 QPSK 740.3MHz – 10MHz (1GHz - 5GHz)

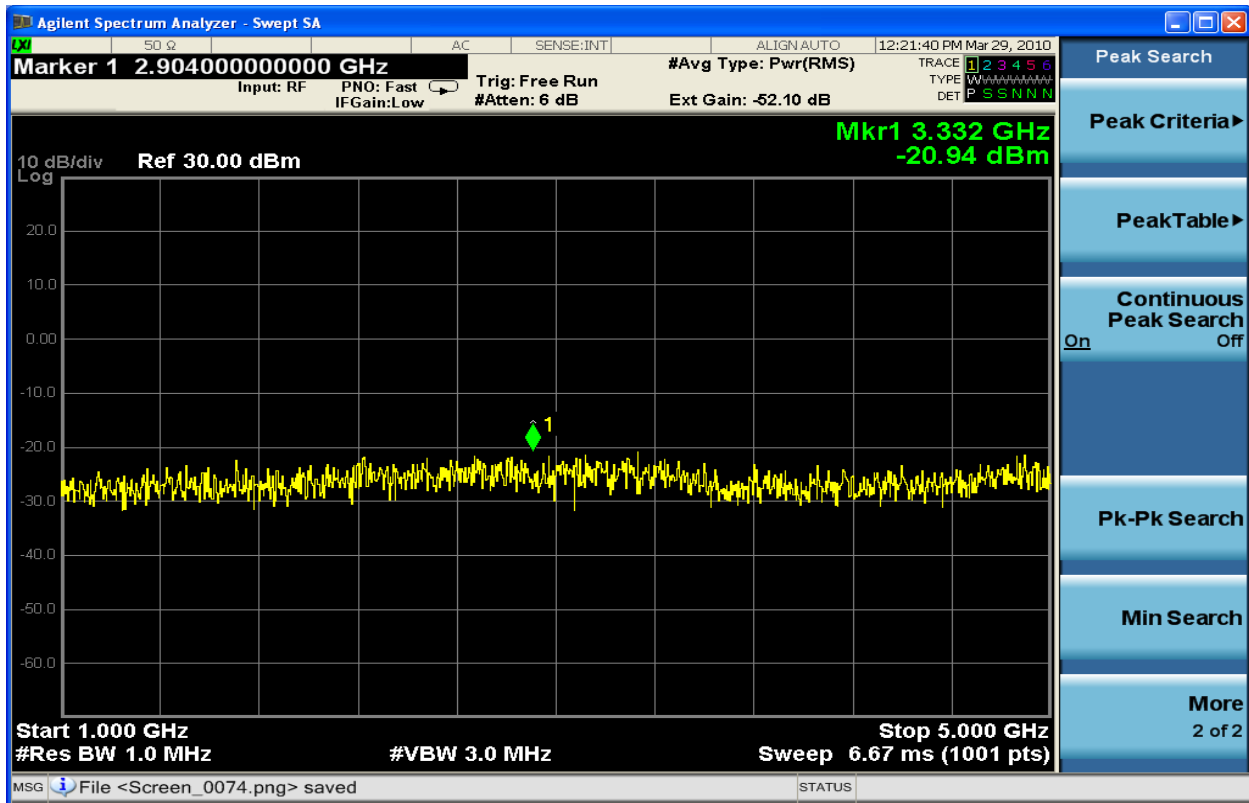

Figure 6-353 Spurious Emission TX1 16QAM 740.3MHz – 10MHz (1GHz - 5GHz)

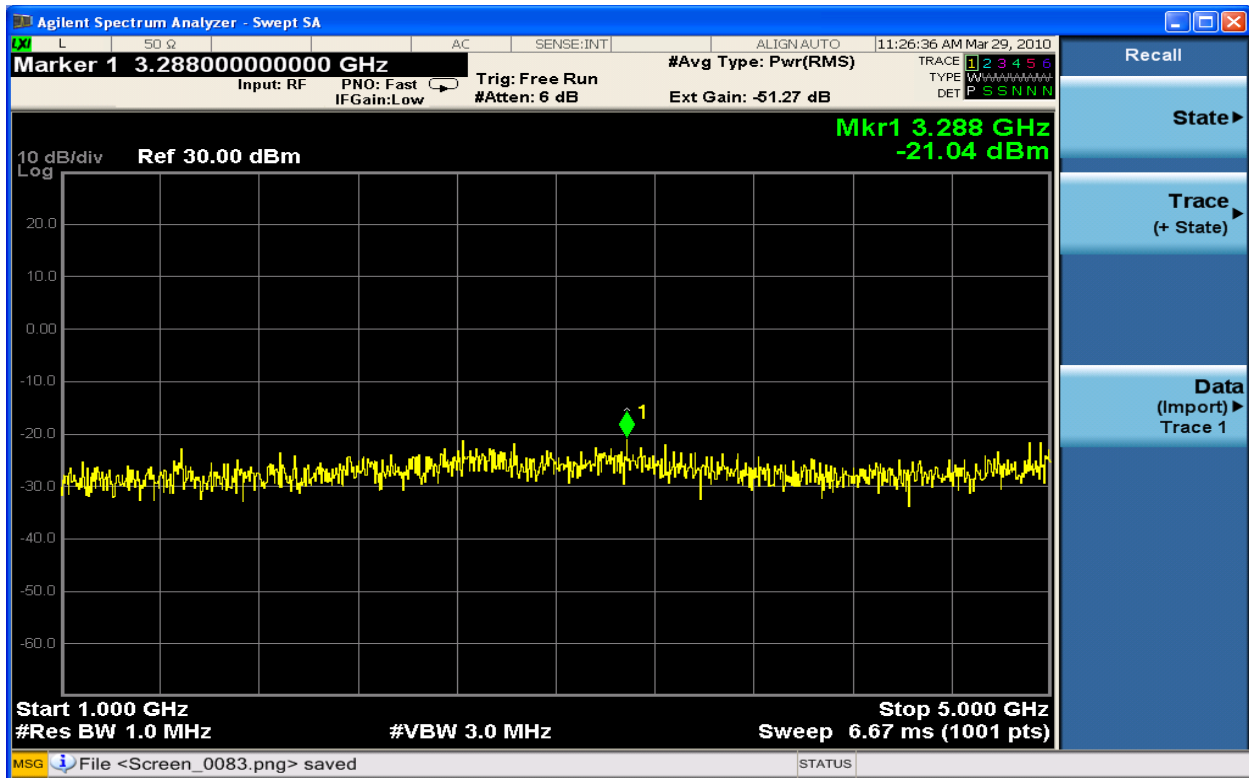

Figure 6-354 Spurious Emission TX2 16QAM 740.3MHz – 10MHz (1GHz - 5GHz)

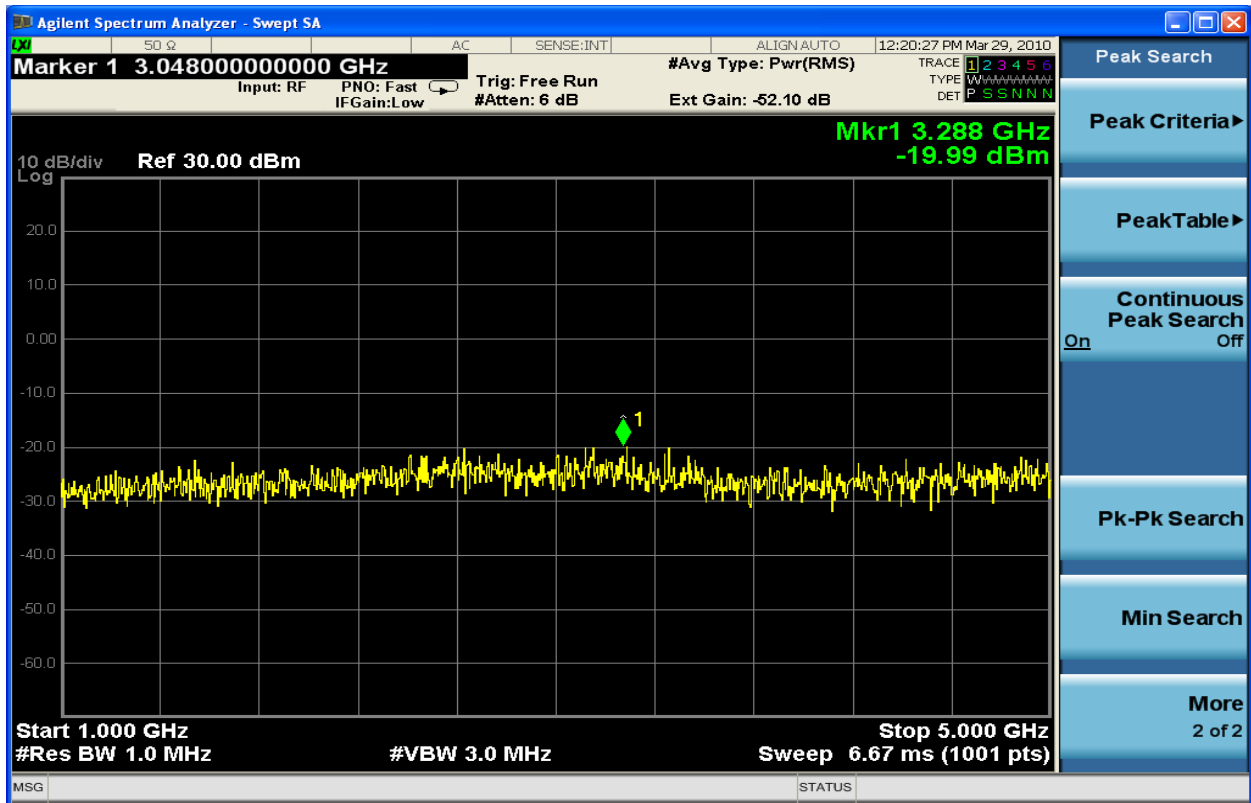

Figure 6-355 Spurious Emission TX1 64QAM 740.3MHz – 10MHz (1GHz - 5GHz)

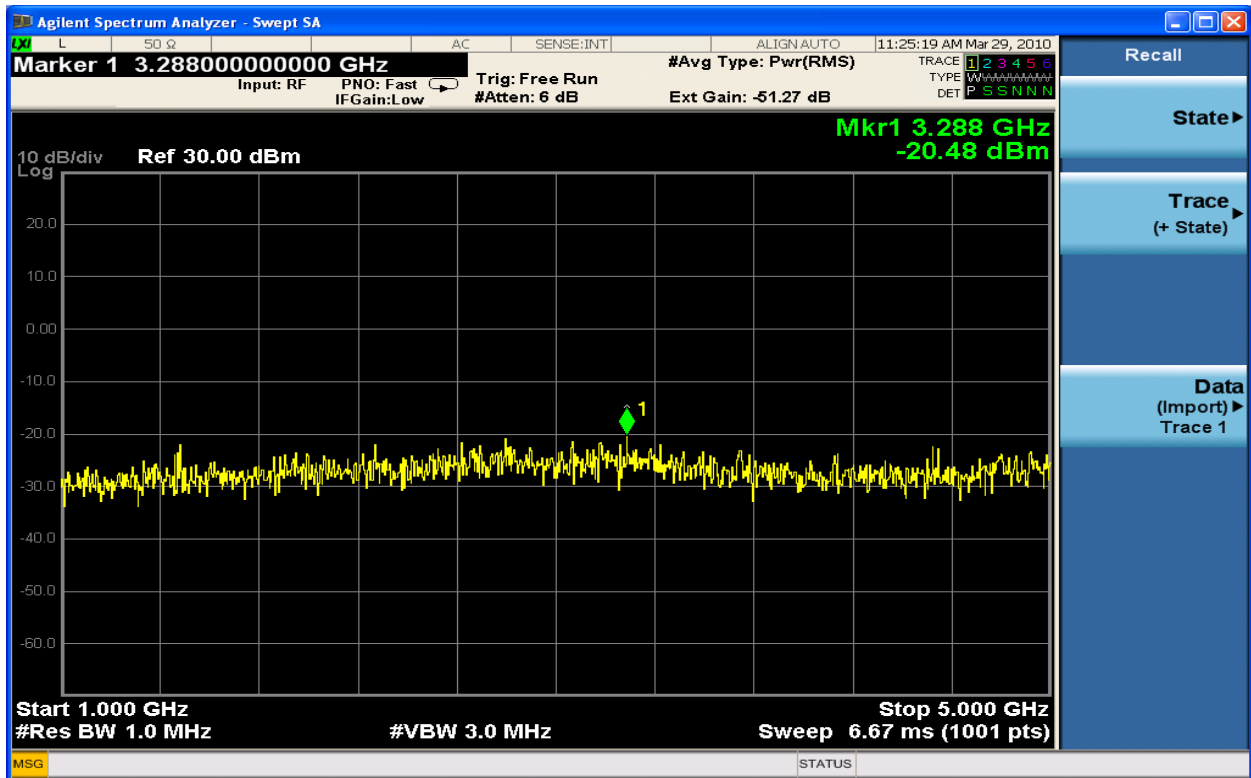

Figure 6-356 Spurious Emission TX2 64QAM 740.3MHz – 10MHz (1GHz - 5GHz)

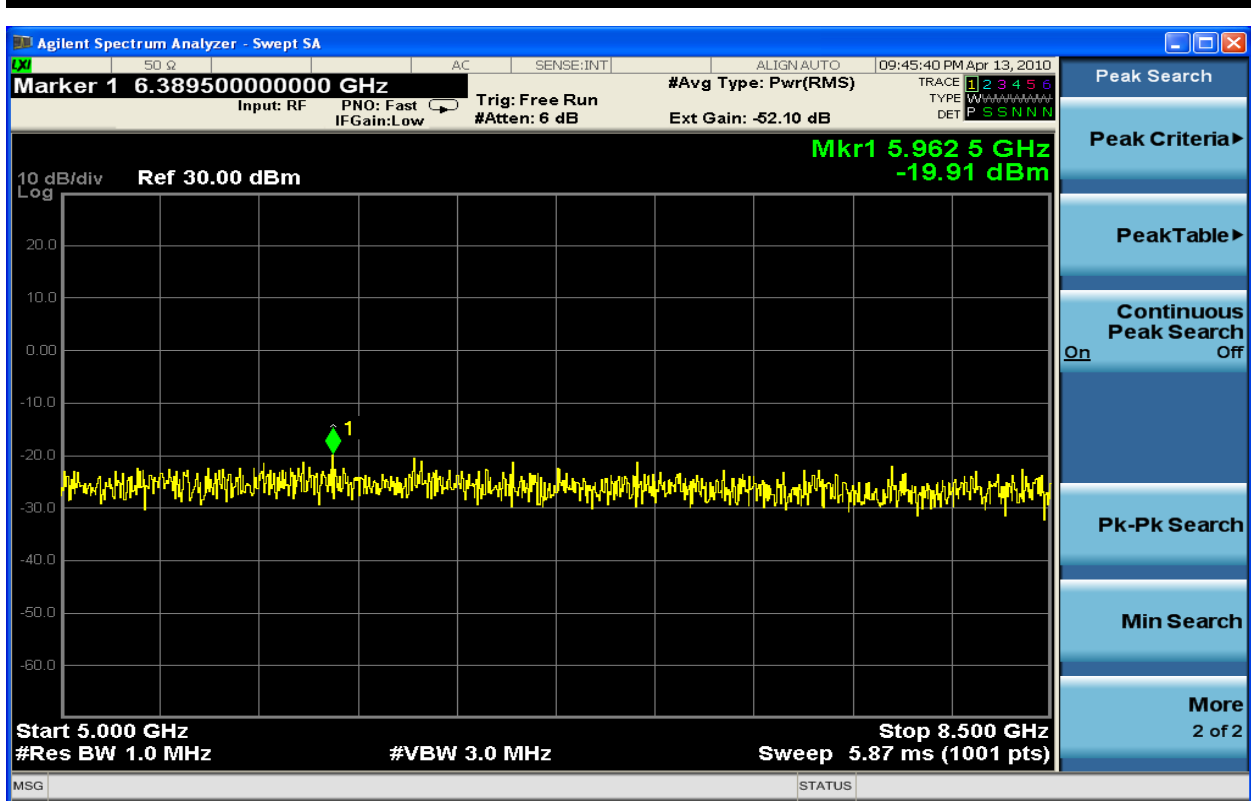

Figure 6-357 Spurious Emission TX1 QPSK 740.3MHz – 10MHz (5GHz - 8GHz)

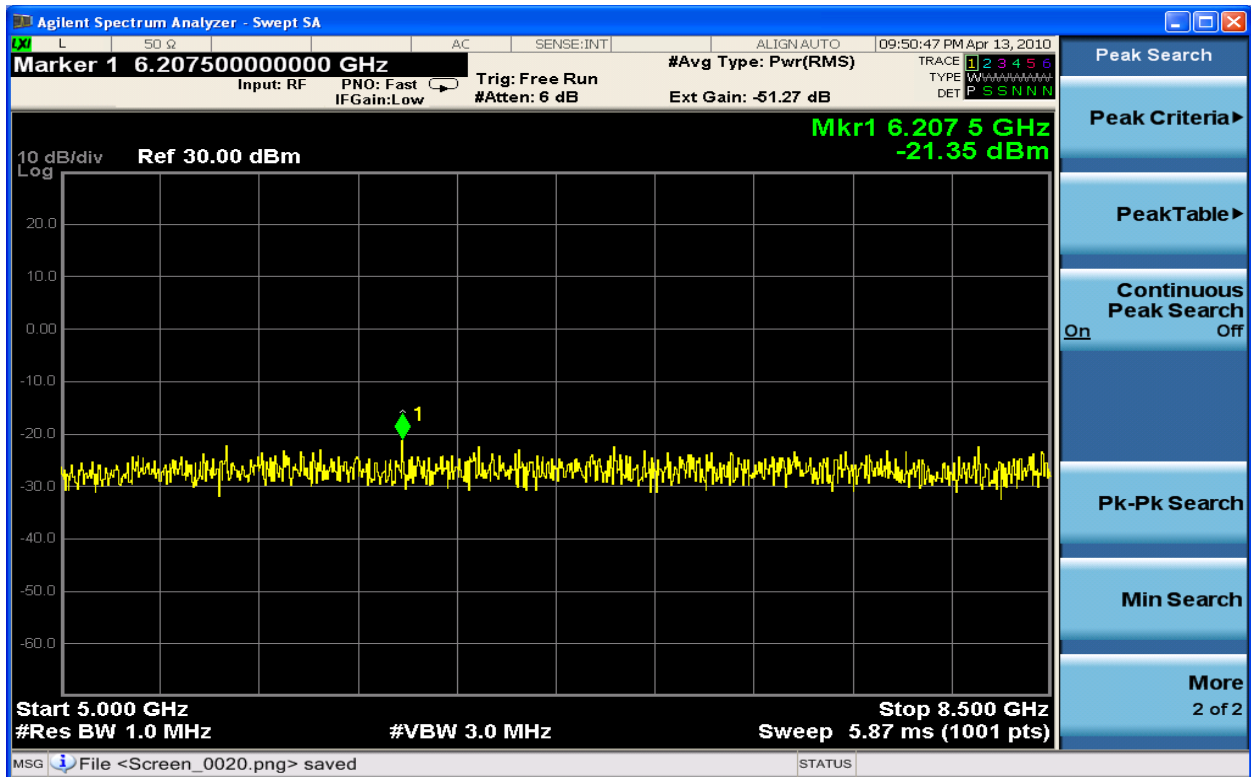

Figure 6-358 Spurious Emission TX2 QPSK 740.3MHz – 10MHz (5GHz - 8GHz)

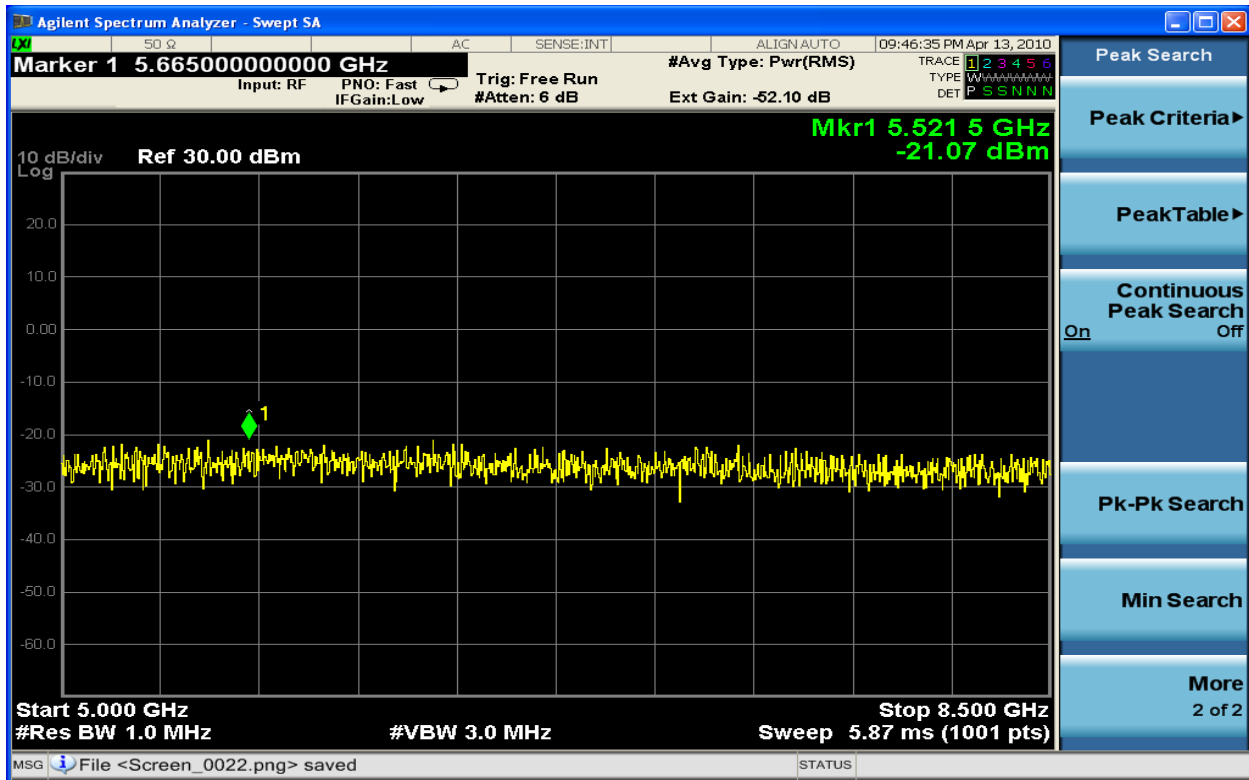

Figure 6-359 Spurious Emission TX1 16QAM 740.3MHz – 10MHz (5GHz - 8GHz)

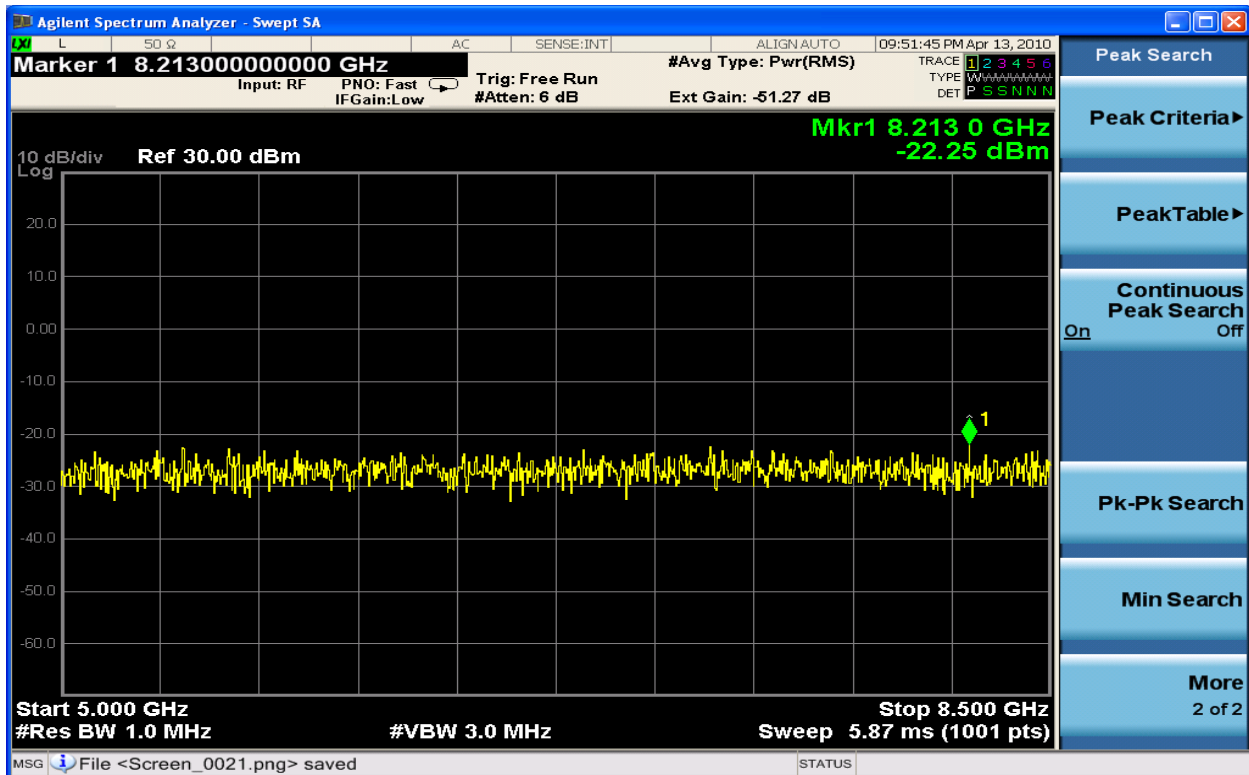

Figure 6-360 Spurious Emission TX2 16QAM 740.3MHz – 10MHz (5GHz - 8GHz)

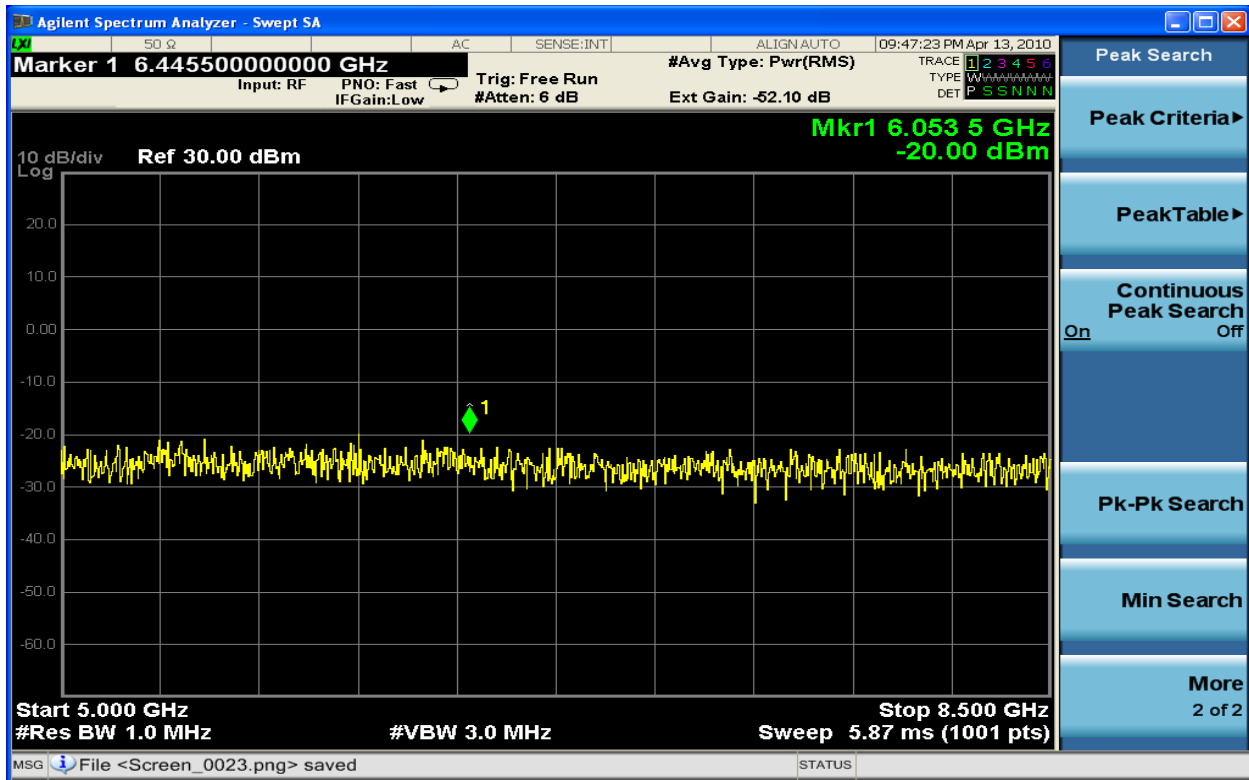

Figure 6-361 Spurious Emission TX1 64QAM 740.3MHz – 10MHz (5GHz - 8GHz)

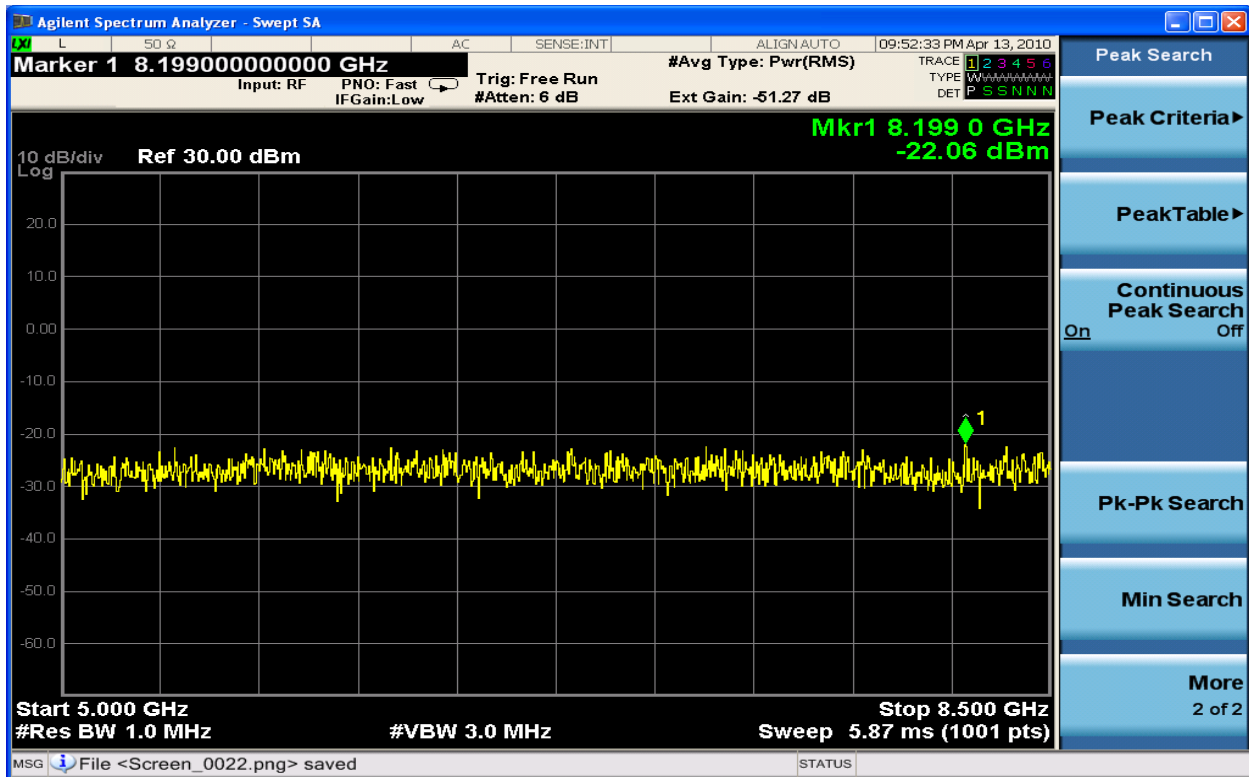

Figure 6-362 Spurious Emission TX2 64QAM 740.3MHz – 10MHz (5GHz - 8GHz)

6.5 Field Strength of Spurious Radiation

Clause 27.53(g)

(g) For operations in the 698-746 MHz band, the power of any emission outside a licensee's frequency band(s) of operation shall be attenuated below the transmitter power (P) within the licensed band(s) of operation, measured in watts, by at least $43 + 10 \log (P)$ dB. Compliance with this provision is based on the use of measurement instrumentation employing a resolution bandwidth of 100 kilohertz or greater. However, in the 100 kilohertz bands immediately outside and adjacent to a licensee's frequency block, a resolution bandwidth of at least 30 kHz may be employed.

Test Setup:

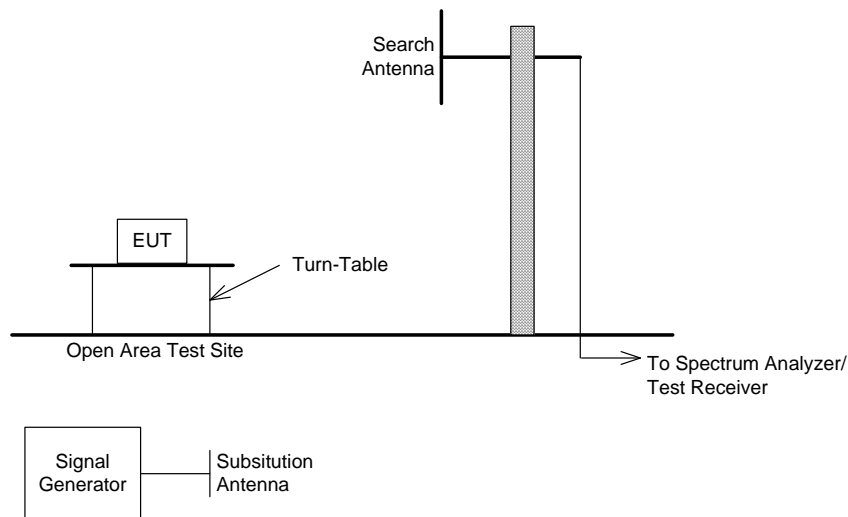

Figure 6-363 RRU Field Strength Set Up / Configuration

Settings Remarks:

1. The tests were conducted in a 10 meter Ambient Free Chamber (AFC) with signal substitution method.
2. The low, medium and high operation frequencies would be evaluated.
3. The frequency range would be start from 30MHz to 10th Harmonic.
4. The measurement would be performed using a peak detector with a 100kHz RBW/VBW below 1GHz and 1MHz RBW/VBW above 1GHz at a distance of 10 meters.
5. Radiated emission band edge check in the 100 kHz bands immediately outside and adjacent to the frequency block would be conducted with the EUT operated the nearest channel to the band edge with the RBW/VBW as 30kHz/100kHz and RMS detector would be applied.

- All modulations (QPSK, 16QAM, and 64QAM) modes and different data rates would be evaluated using representative waveforms of all 3-modulation schemes. The test would cover 5 and 10MHz bandwidth configurations.

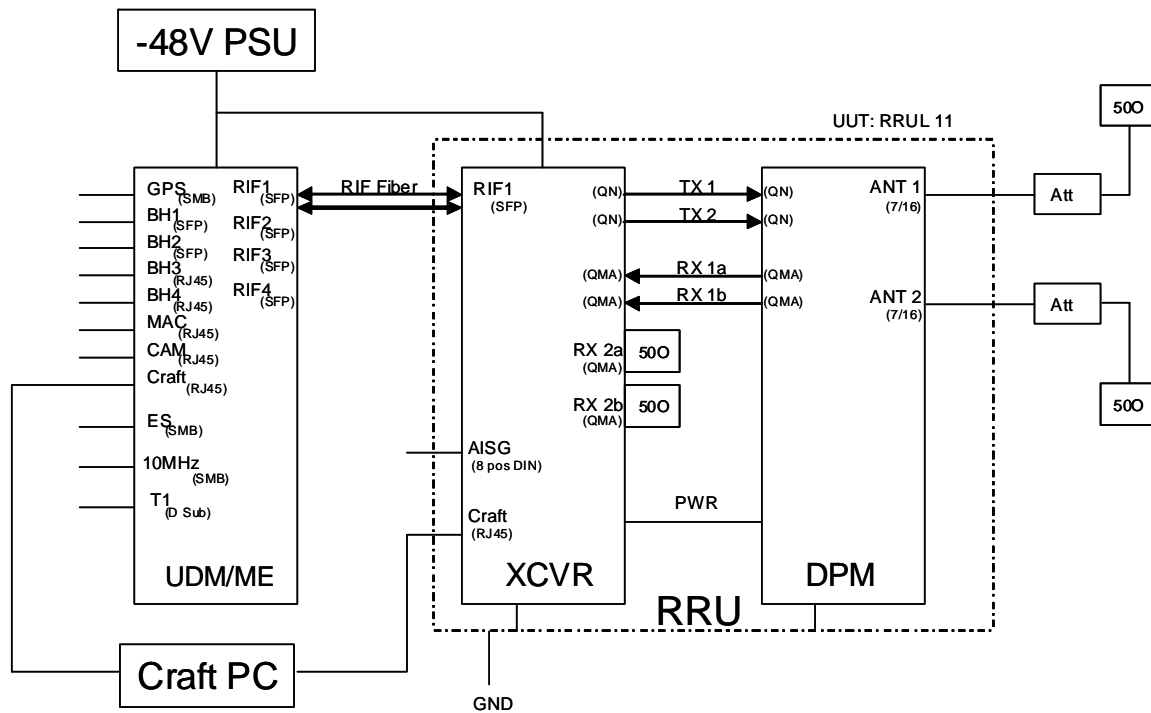

Figure 6-364 RRU EMC Set Up / Configuration

FCC 2.1053: Measurements required: Field strength of spurious radiation.

Measurements shall be made to detect spurious emissions that may be radiated directly from the cabinet, control circuits, power leads, or intermediate circuit elements under normal conditions of installation and operation. Curves or equivalent data shall be supplied showing the magnitude of each harmonic and other spurious emission. For this test, single sideband, independent sideband, and controlled carrier transmitters shall be modulated under the conditions specified in paragraph (c) of FCC 2.1049, as appropriate.

FCC 2.1057: Frequency spectrum to be investigated.

In all of the measurements set forth in 2.1051 and 2.1053, the spectrum shall be investigated from the lowest radio frequency signal generated in the equipment, without going below 9 kHz, up to at least the tenth harmonic of the highest fundamental frequency or to 40 GHz, whichever is lower. Particular attention should be paid to harmonics and sub-harmonics of the carrier frequency as well as to those frequencies removed from the carrier by multiples of the oscillator frequency. Radiation at the frequencies of multiplier stages should also be checked. The amplitude of spurious emissions which are attenuated more than 20 dB below the permissible value need not be reported.

Results are tabulated and derived from measurements made in the 10 meter anechoic chamber.

EMC Reference Report: K0001750-TR-EMC-01-01, 14 April 2010
Flextronics Design Validation Centre, 21 Richardson Side Road, Kanata On, K2K 2C1, Canada
Accreditation: SCC ISO/IEC 17025

Table 6-11 Spurious Emissions ERP

Frequency (MHz)	Field Strength (dBuV)	Signal Substitution (dBm)	Cable Loss (dB)	Antenna Gain (dBi)	dBi to dBd Conversion	ERP (dBm)	Limit (dBm)	Margin (dB)
2209.55	46.51	-64.27	2.59	9.62	2.15	-59.4	-13	46.4

Remarks: All other spurious have more margin

All emissions in the radiated emission scan were low compared to the FCC Part 15 limits. The worst case spurious emission at 2209.55MHz was verified using substitution method as tabulated above.

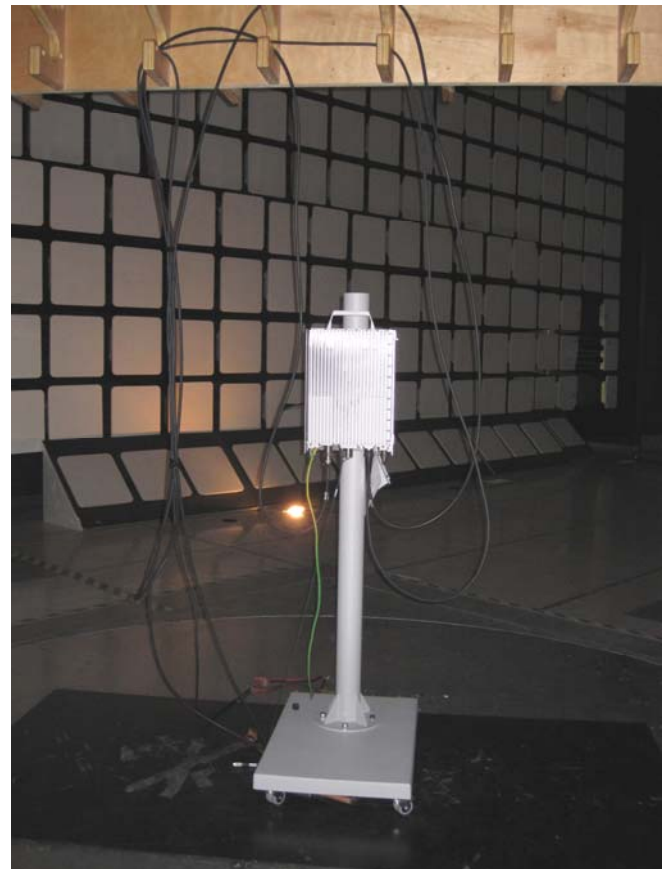

Figure 6-365 Radiated Emissions Set Up Photo's

6.6 Frequency Stability

Frequency Stability Clause 27.54

27.54 Frequency Stability. - The frequency stability shall be sufficient to ensure that the fundamental emissions stay within the authorized bands of operation.

FCC Clause 2.1055 Frequency Stability

2.1055 Measurements required: Frequency stability.

- (a) The frequency stability shall be measured with variation of ambient temperature as follows:
 - (1) From -30° to $+50^{\circ}$ centigrade for all equipment except that specified in paragraphs (a)(2) and (3) of this section
- (b) Frequency measurements shall be made at the extremes of the specified temperature range and at intervals of not more than 10° centigrade through the range.
- (d) The frequency stability shall be measured with variation of primary supply voltage as follows:
 - (1) Vary primary supply voltage from 85 to 115 percent of the nominal value for other than hand carried battery equipment.

Test Setup

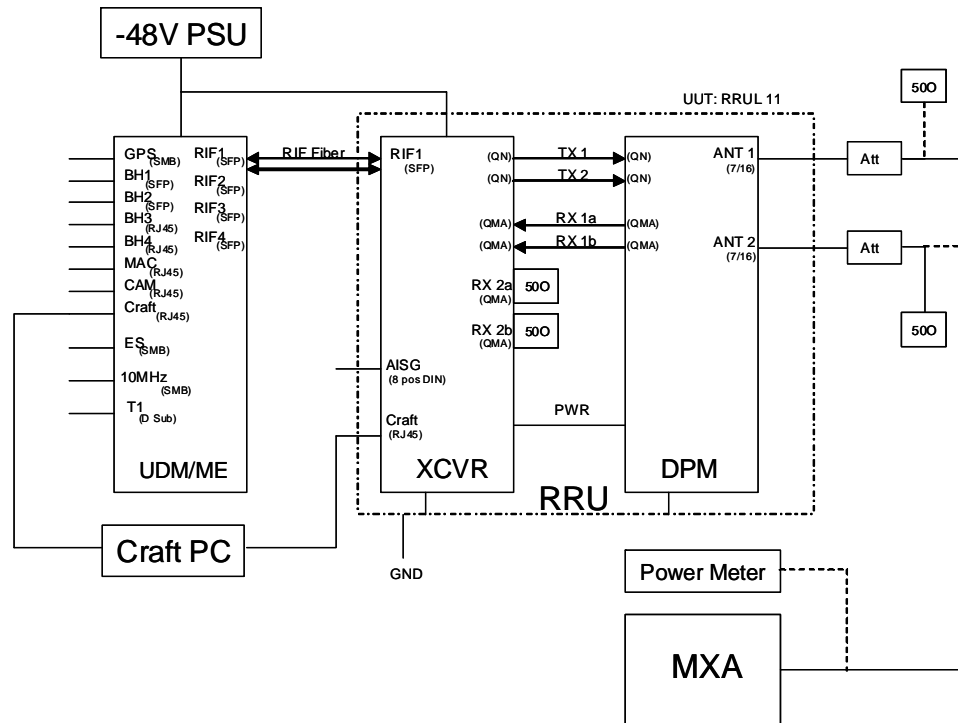

Figure 6-366 RRU Stability Set Up / Configuration

Test Conditions:

Extreme Temperature Condition: -30°C to 50°C
 Extreme Voltage Conditions: ±15% of standard voltage condition.

Settings Remarks

1. The EUT would be operated and frequency offset / error monitored over the variables.
2. The EUT would be connected to a spectrum analyzer. The frequency stability would be determined by the frequency counter function of the spectrum analyzer.
3. Test would be conducted at the temperature range from -30°C to 50°C degree with 10°C intervals. Measurement would also be conducted with varying the primary supply voltage from 85% to 115% of the nominal value.
4. Tabulated results and plots are compiled and presented in this section.

Table 6-12: Frequency Stability vs. Temperature / Voltage Variation

Temperature (°C)	DC (V)	Frequency Error (Hz)	Time	Date
-30	40	-3.5611	10:15	31-03-10
-30	48	-0.6377	10:15	31-03-10
-30	55	+5.1222	10:15	31-03-10
-20	40	+3.6686	11:05	31-03-10
-20	48	-6.4742	11:05	31-03-10
-20	55	-5.5168	11:05	31-03-10
-10	40	-3.8634	11:50	31-03-10
-10	48	-4.5541	11:50	31-03-10
-10	55	+4.2287	11:50	31-03-10
0	40	-0.7053	13:00	31-03-10
0	48	+5.3175	13:00	31-03-10
0	55	-5.2174	13:00	31-03-10
+10	40	+1.8918	13:45	31-03-10
+10	48	-0.2931	13:45	31-03-10
+10	55	-7.1147	13:45	31-03-10
+20	40	-1.2629	15:00	31-03-10
+20	48	+3.3585	15:00	31-03-10
+20	55	+0.4670	15:00	31-03-10
+30	40	-1.5409	15:45	31-03-10
+30	48	-2.0396	15:45	31-03-10
+30	55	+2.4265	15:45	31-03-10
+40	40	+1.5464	16:50	31-03-10
+40	48	+7.2670	16:50	31-03-10
+40	55	-2.6486	16:50	31-03-10
+50	40	-0.4414	17:35	31-03-10
+50	48	-3.2579	17:35	31-03-10
+50	55	+6.0012	17:35	31-03-10

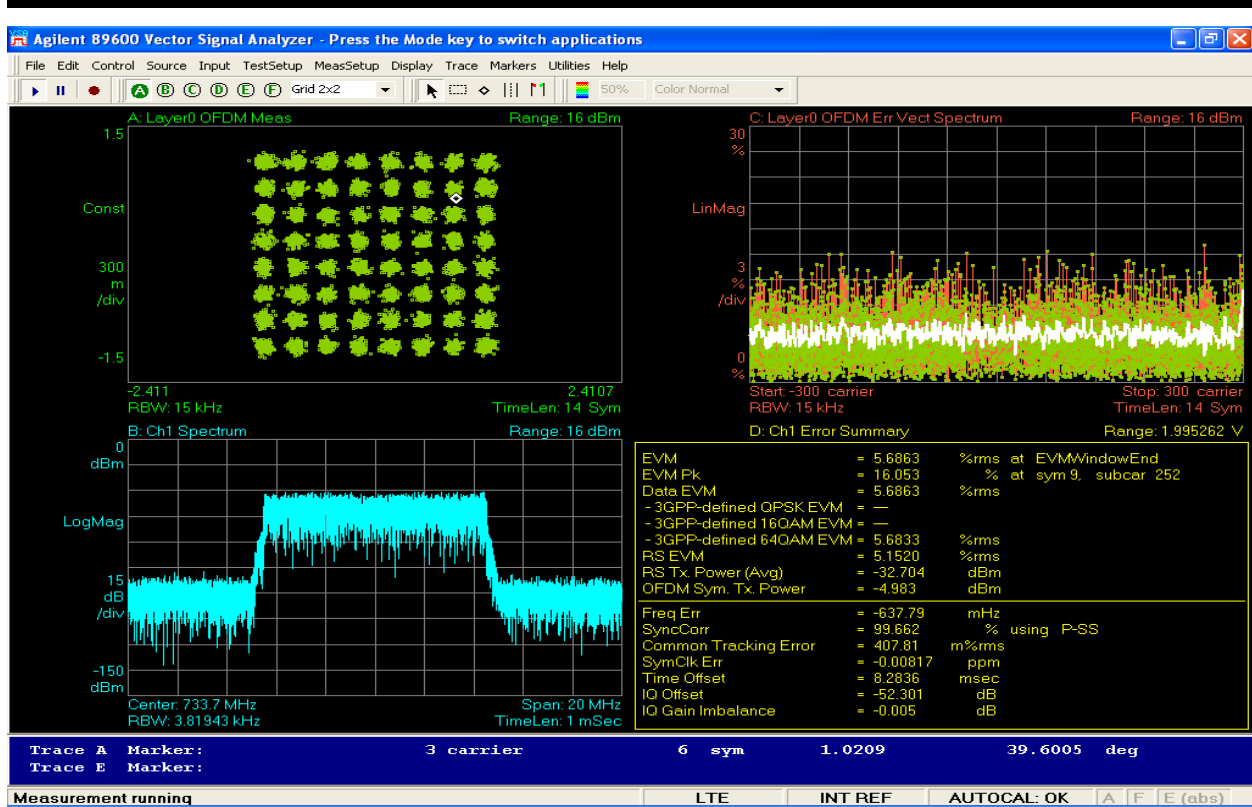

Figure 6-367 Stability - 10MHz @ -30C

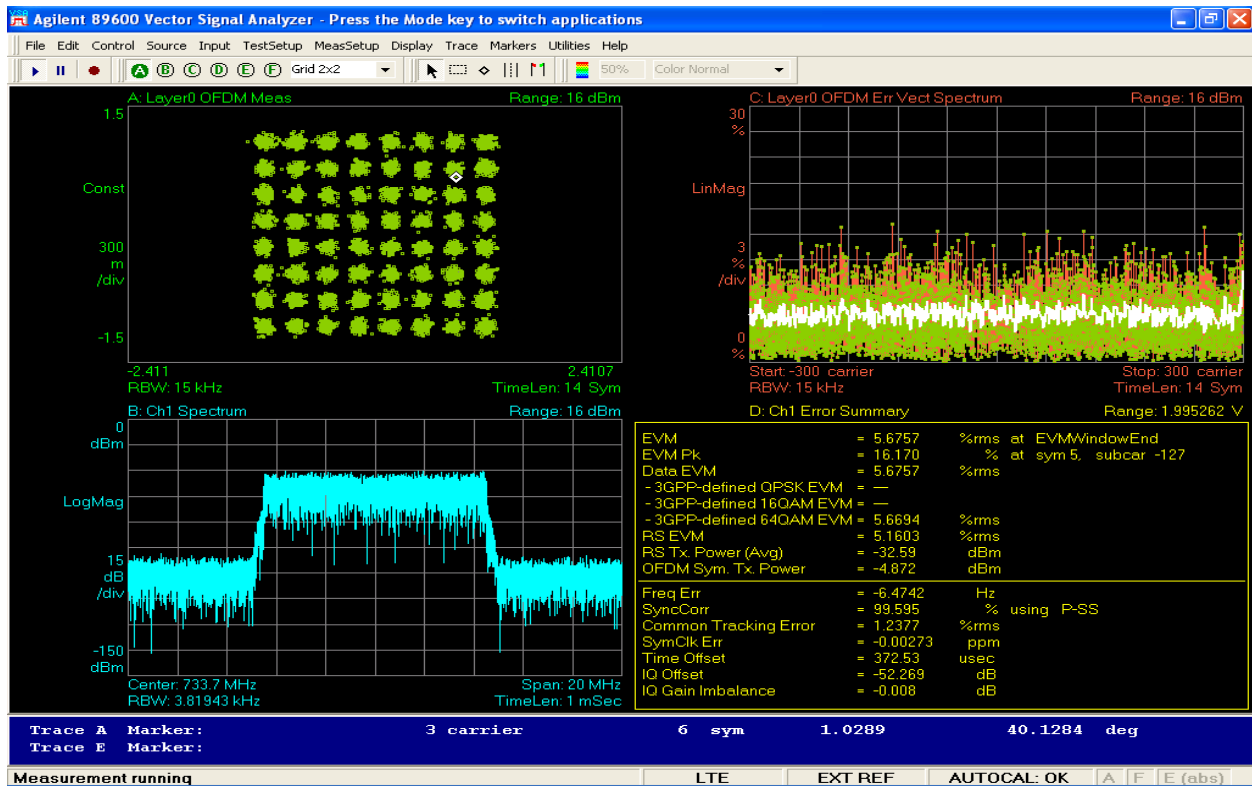

Figure 6-368 Stability 10MHz @ -20C

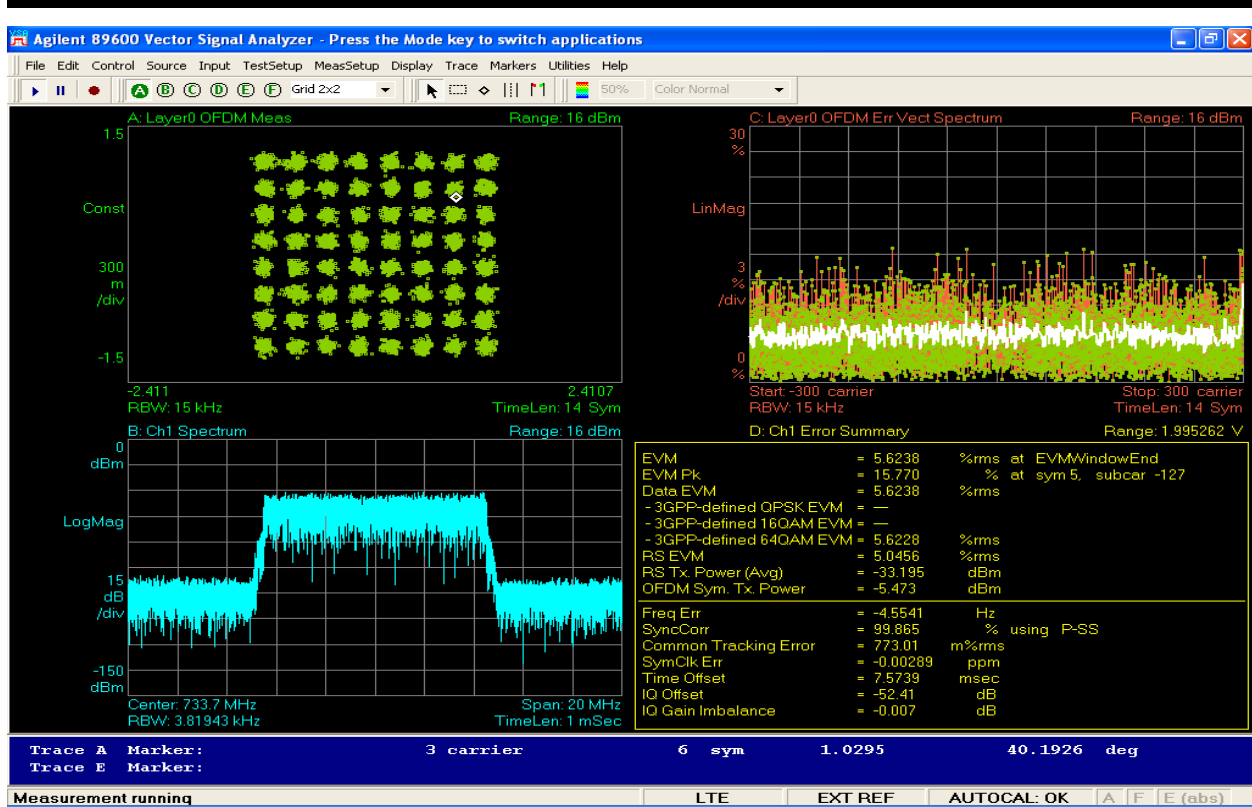

Figure 6-369 Stability 10MHz @ -10C

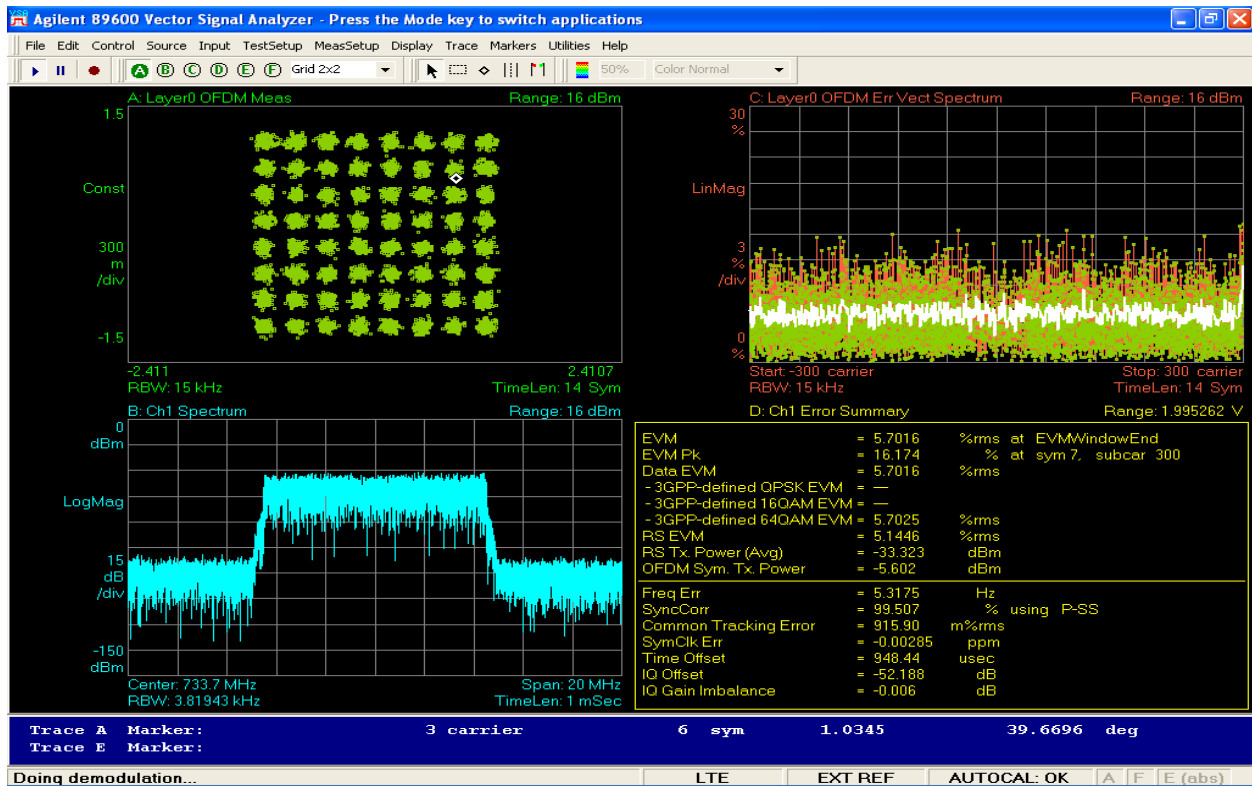

Figure 6-370 Stability 10MHz @ 0C

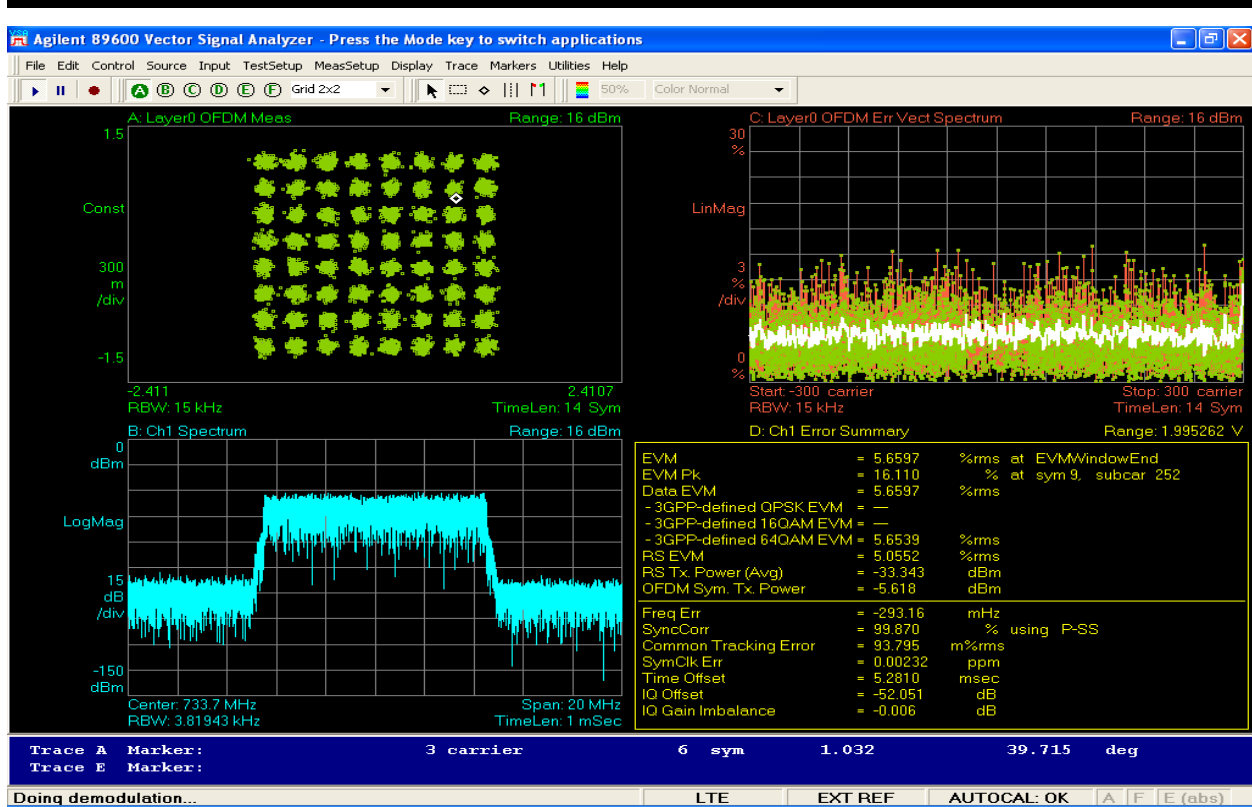

Figure 6-371 Stability 10MHz @ +10C

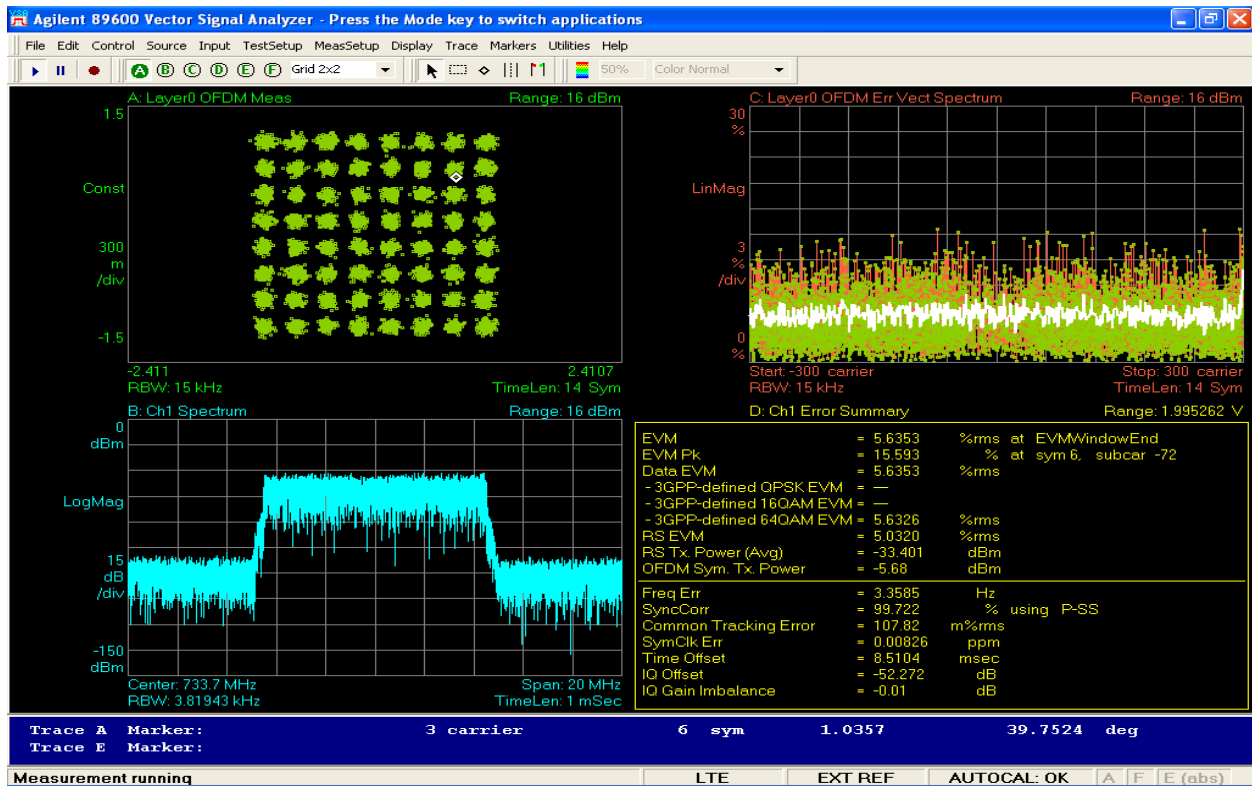

Figure 6-372 Stability 10MHz @ +20C

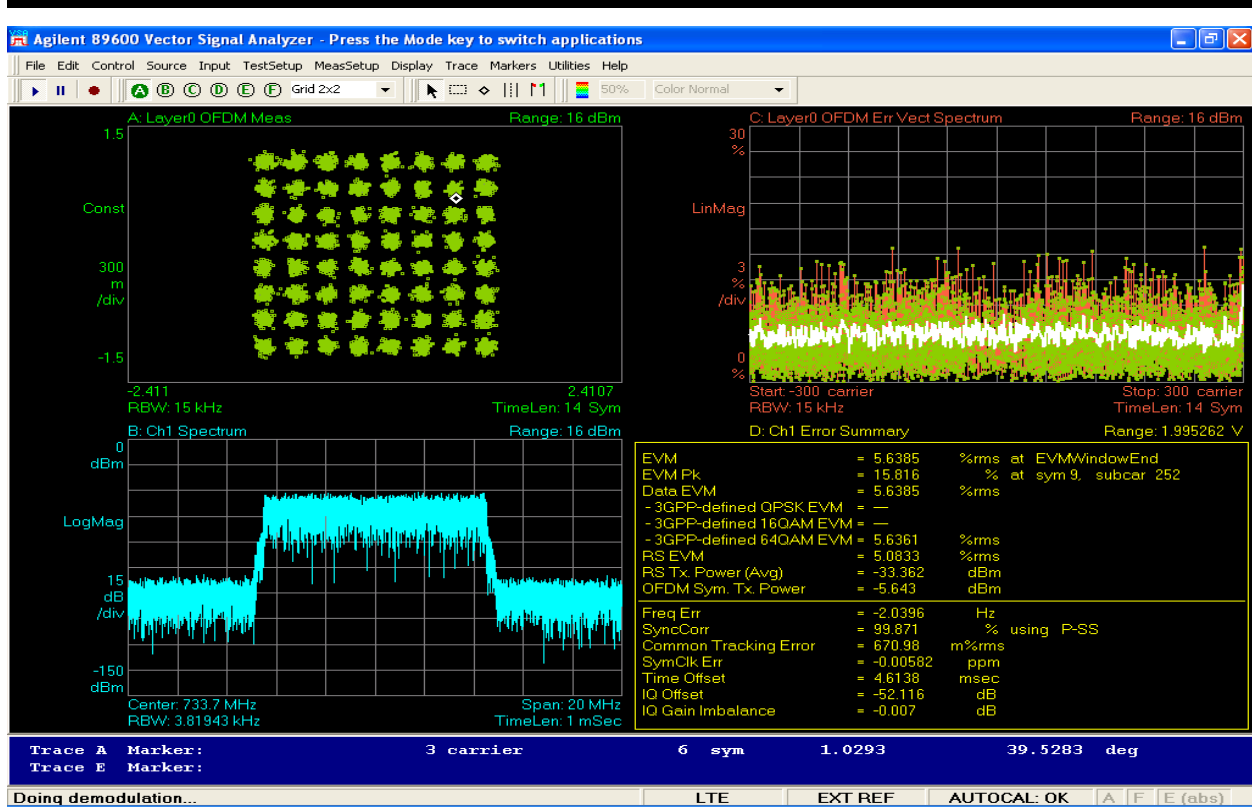

Figure 6-373 Stability 10MHz @ +30C

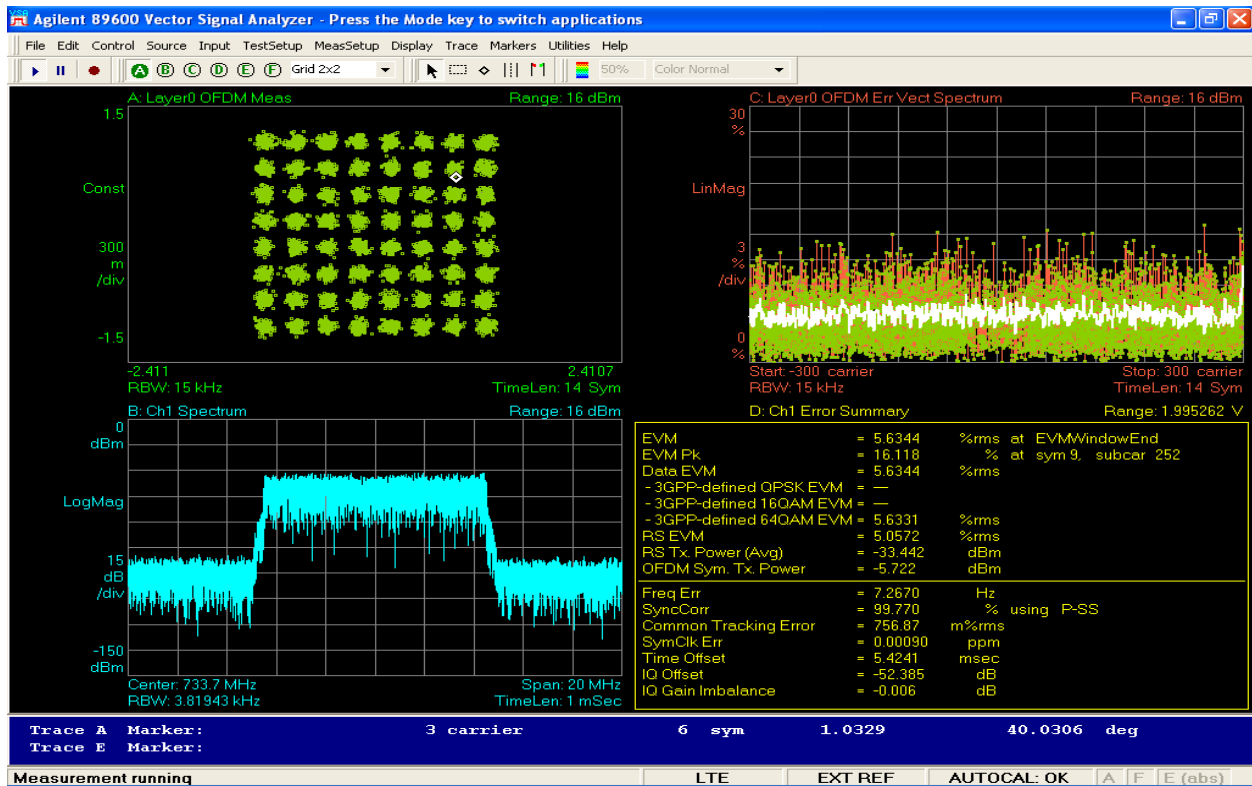

Figure 6-374 Stability 10MHz @ +40C

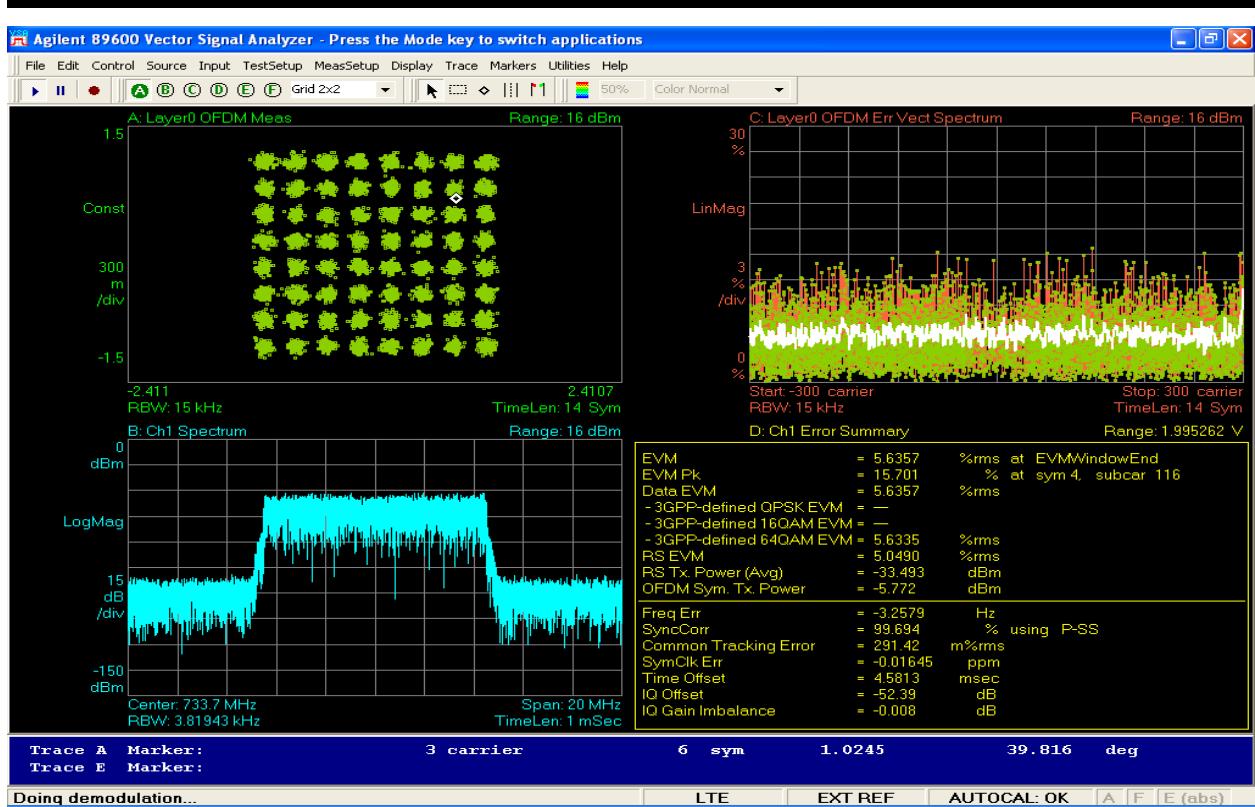

Figure 6-375 Stability 10MHz @ +50C

6.7 Submission Exhibits

2.1033 Submission Exhibits

- Schematics
- Bill of Materials
- Block Diagram
- User Manual
- Letter Head Technical Operation and Description
- Letter Head MPE Calculation
- Letter Head, Cover Letter, Confidentiality Request
- External Photo's
- Internal Photo's
- Tune up Procedure
- FCC Form 731
- Label Details (Format and location)
- Set-up Photo's
- Test Report