

Figure 6-135: 10MHz Occupied Bandwidth TX1\_QPSK at 737.0 MHz

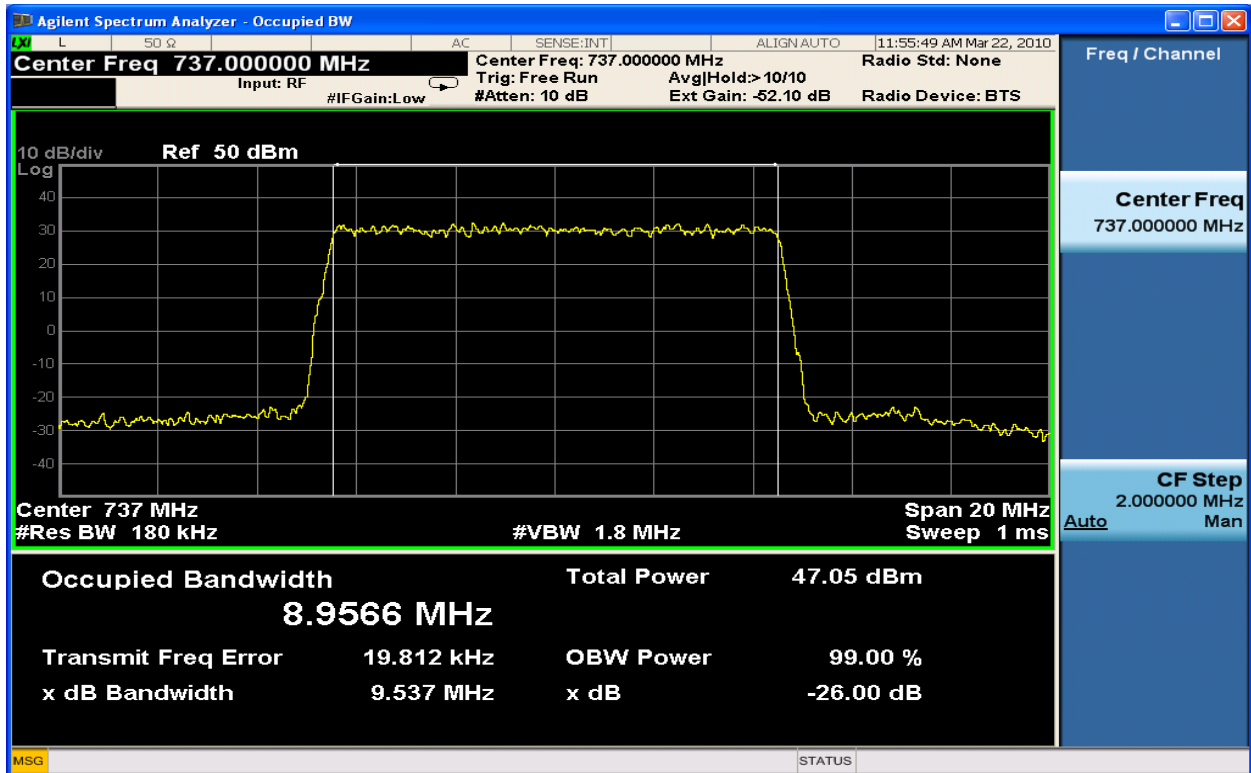

Figure 6-136: 10MHz Occupied Bandwidth TX2\_QPSK at 737.0 MHz

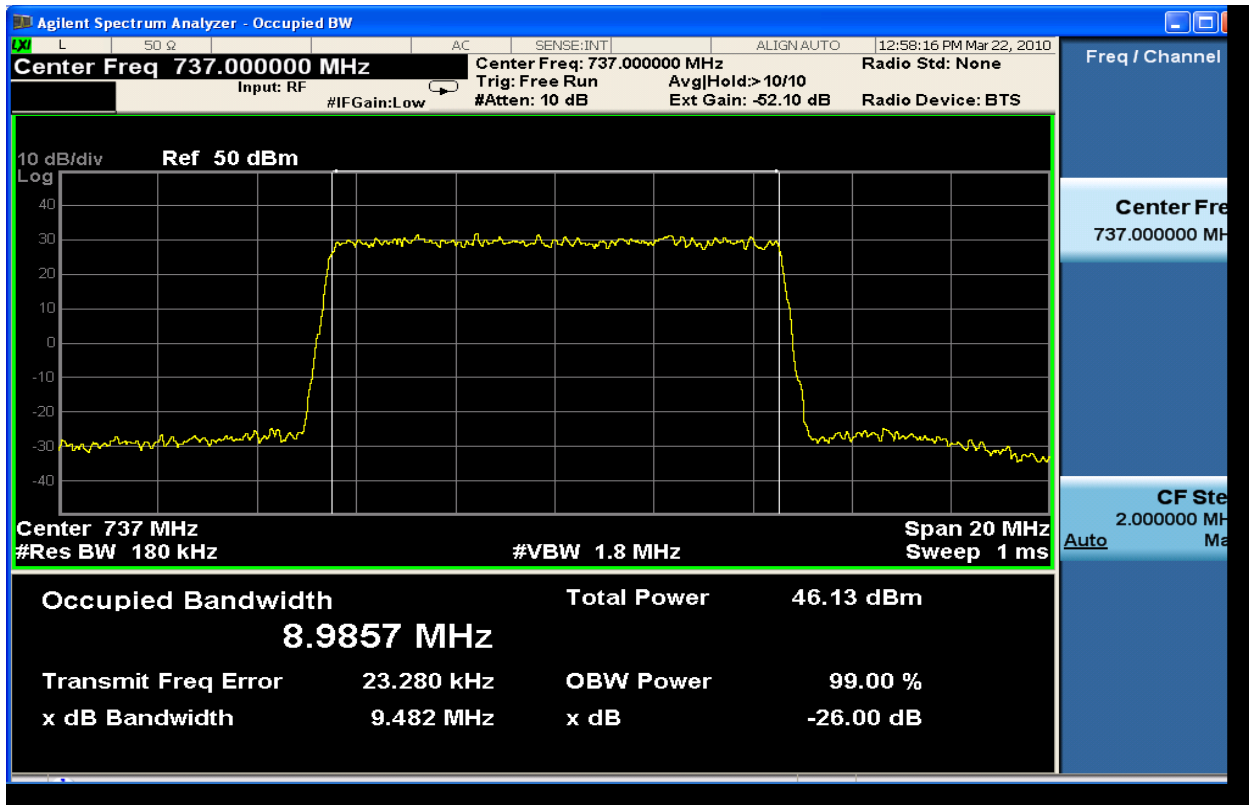

Figure 6-137: 10MHz Occupied Bandwidth TX1\_16QAM at 737.0 MHz

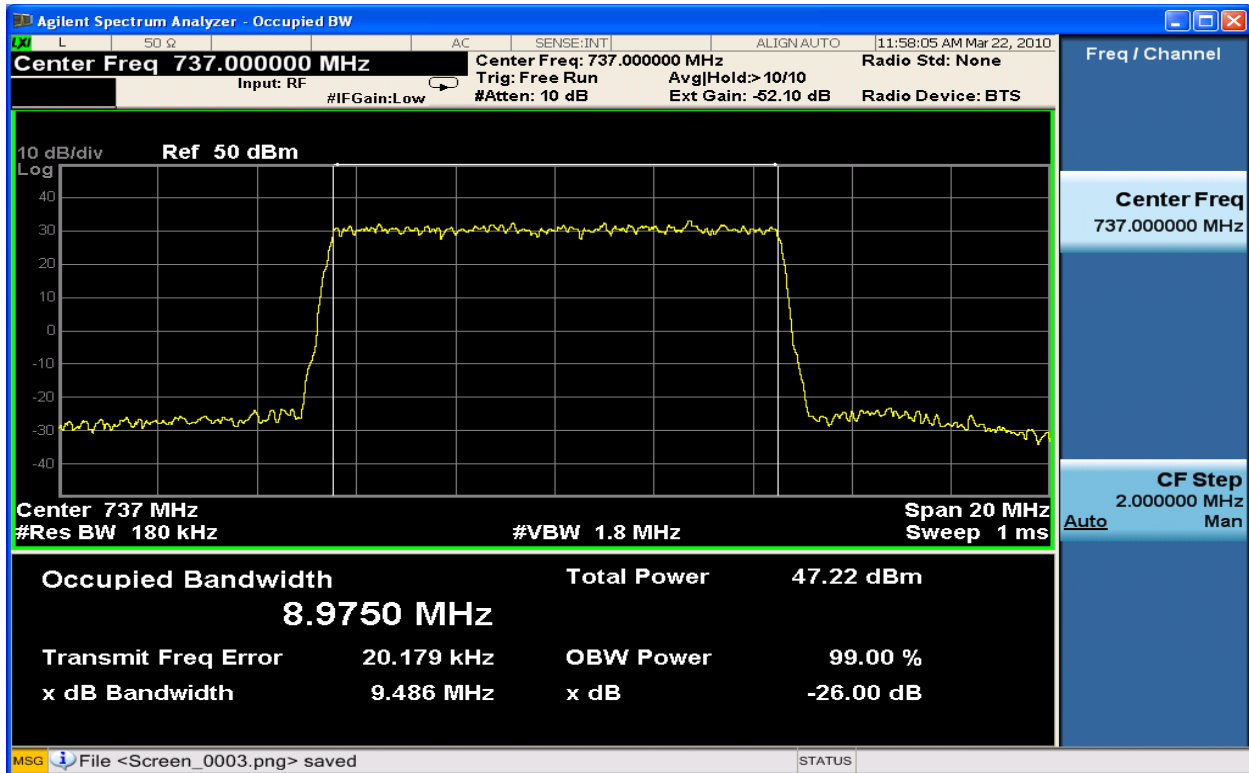

Figure 6-138: 10MHz Occupied Bandwidth TX2\_16QAM at 737.0 MHz

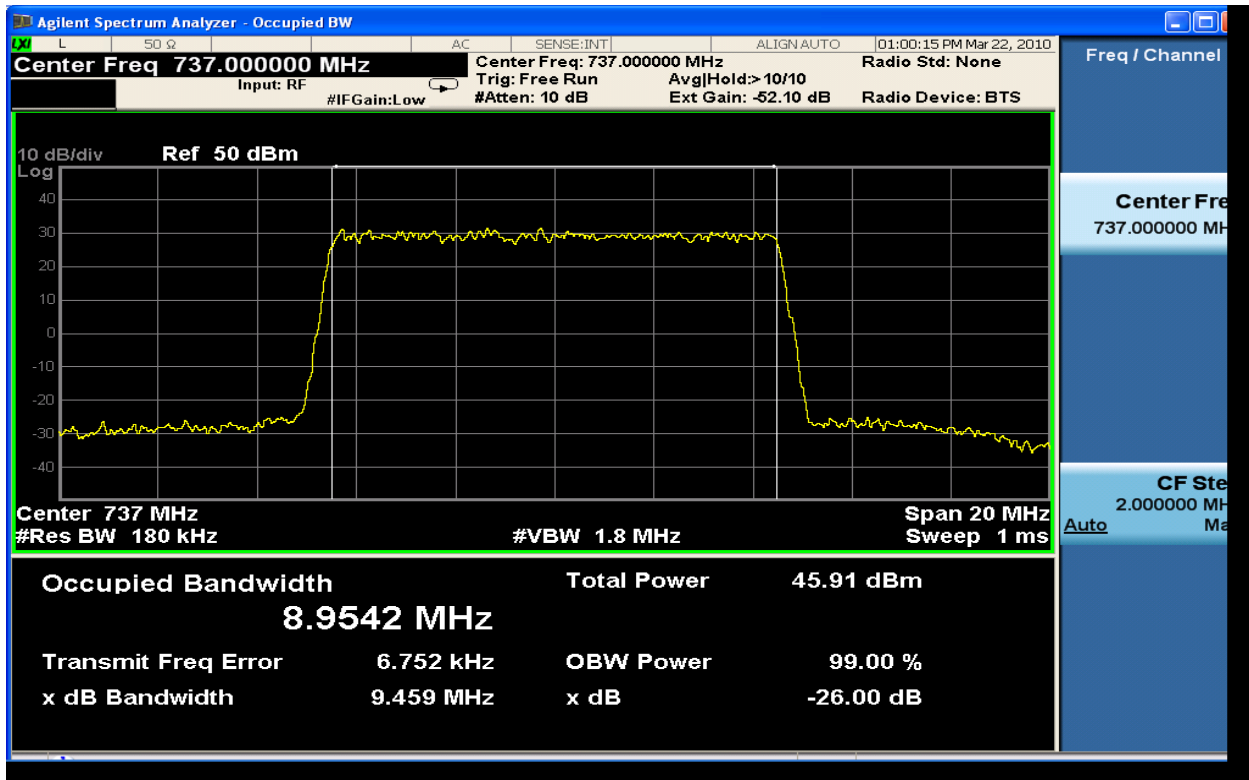

Figure 6-139: 10MHz Occupied Bandwidth TX1\_64QAM at 737.0 MHz

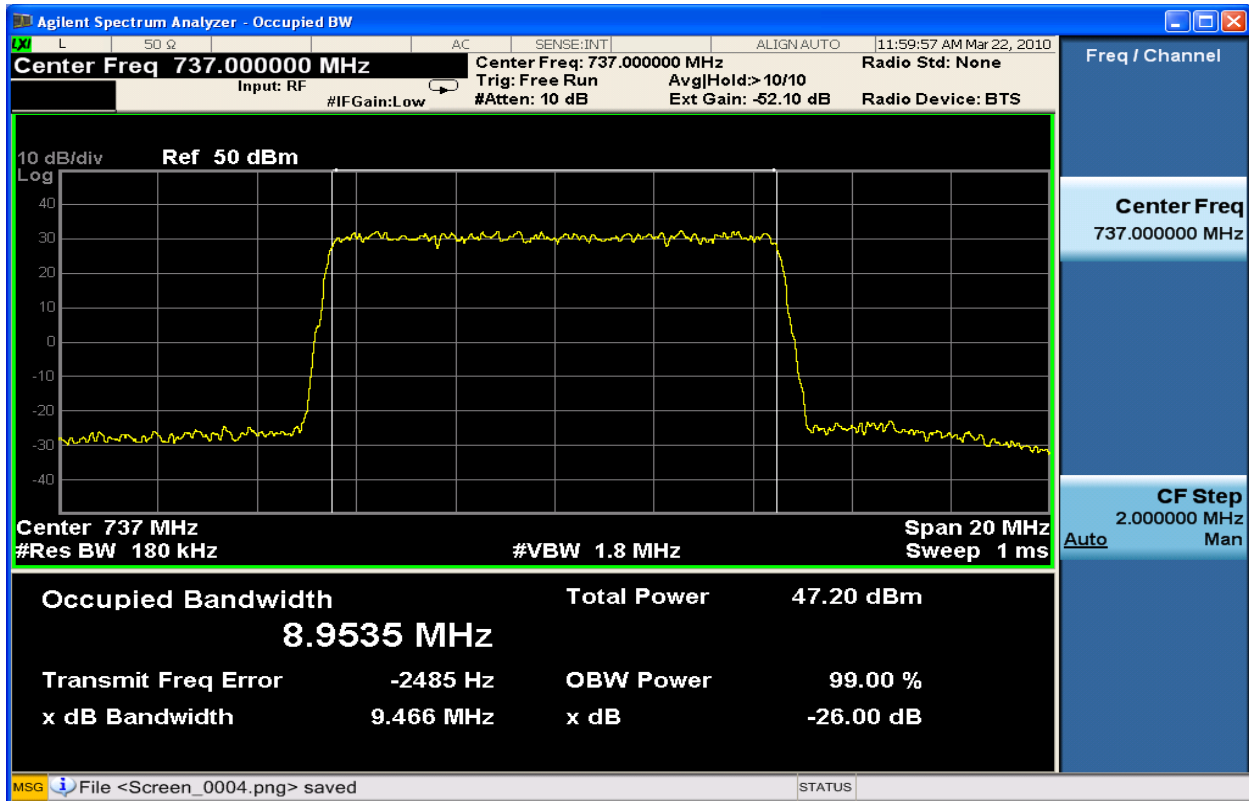

Figure 6-140: 10MHz Occupied Bandwidth TX2\_64QAM at 737.0 MHz

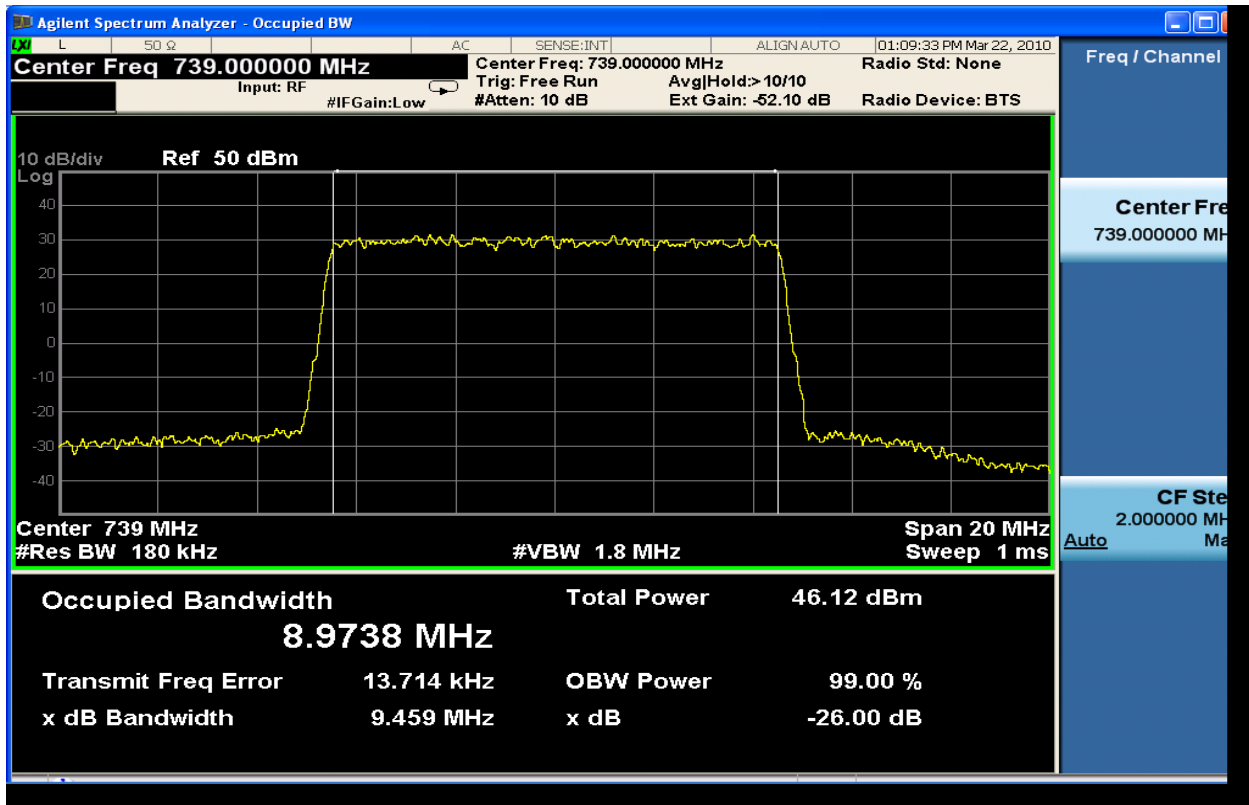

Figure 6-141: 10MHz Occupied Bandwidth TX1\_QPSK at 739.0 MHz

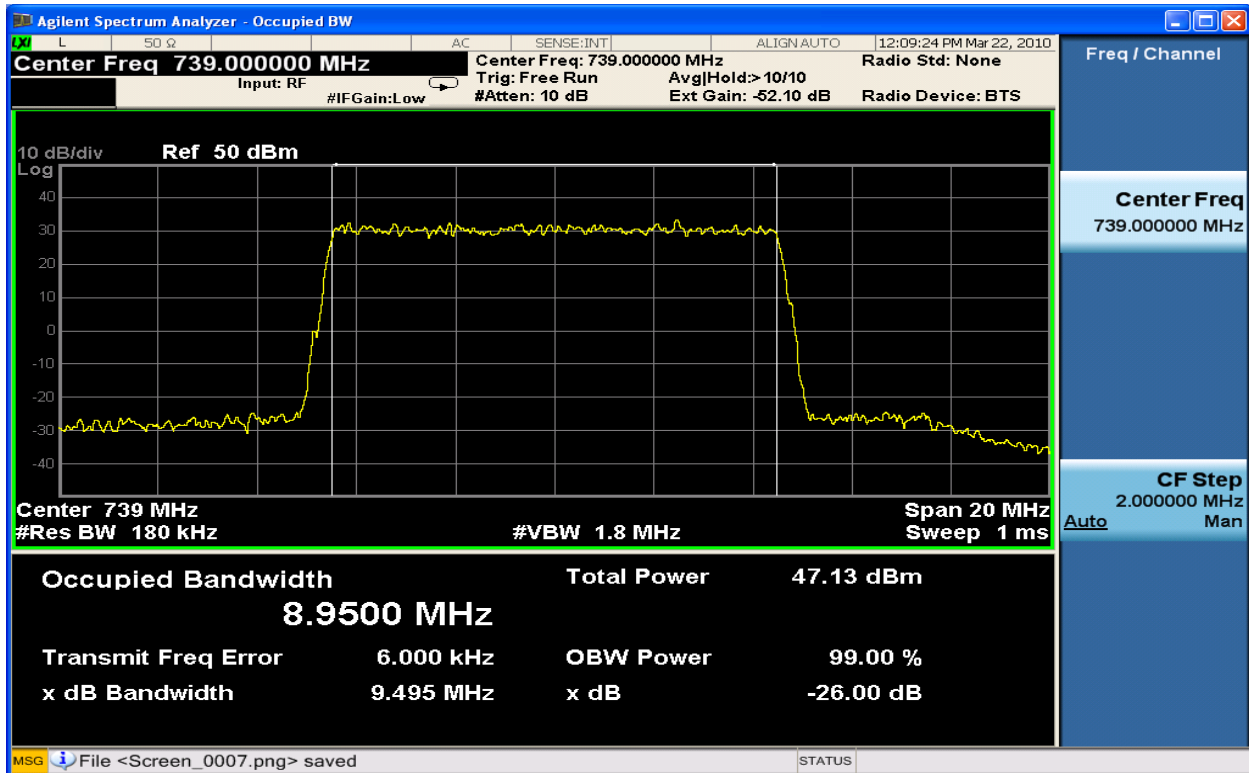

Figure 6-142: 10MHz Occupied Bandwidth TX2\_QPSK at 739.0 MHz

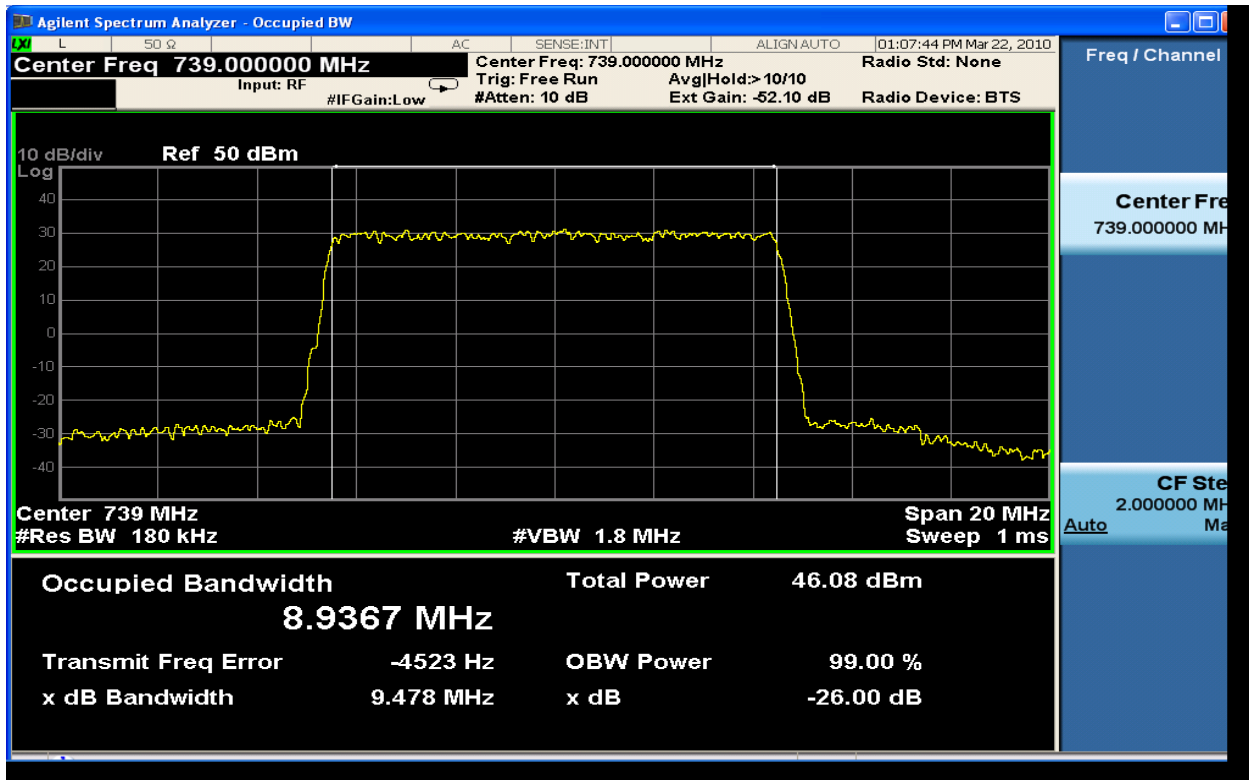

Figure 6-143: 10MHz Occupied Bandwidth TX1\_16QAM at 739.0 MHz

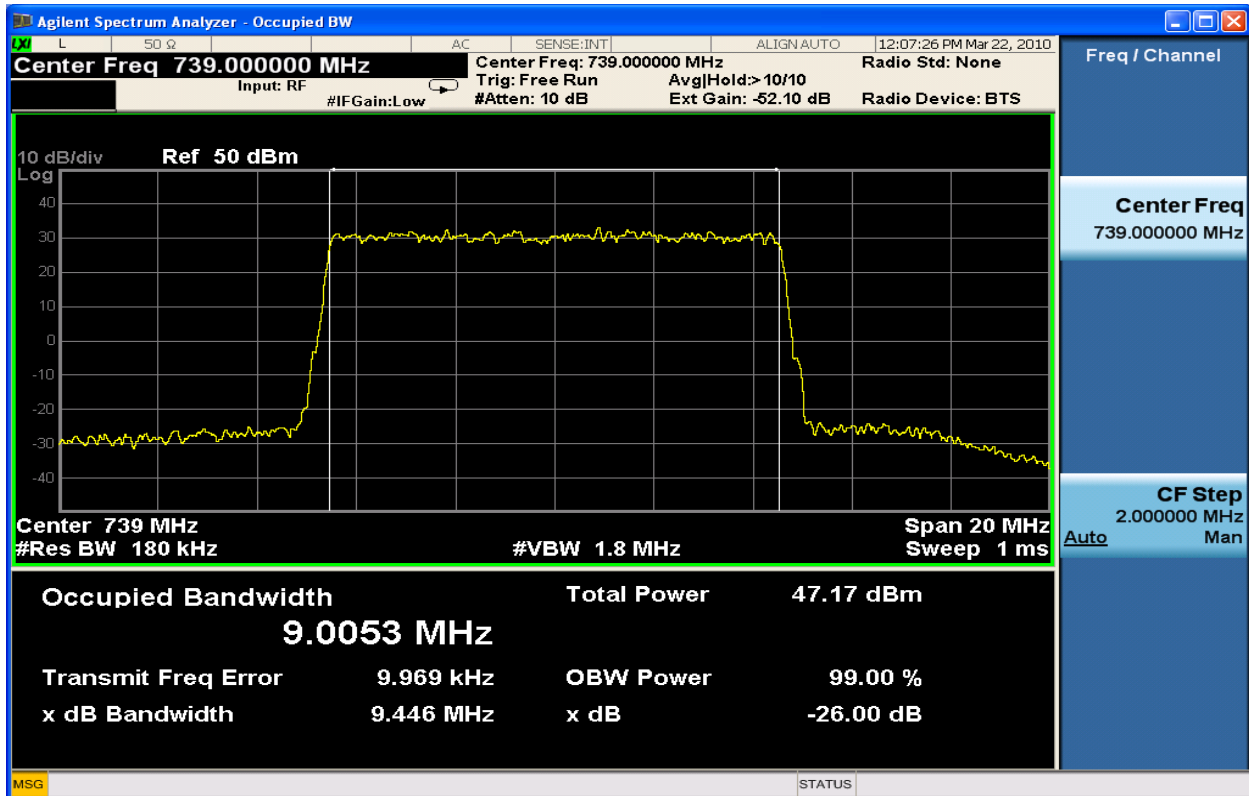

Figure 6-144: 10MHz Occupied Bandwidth TX2\_16QAM at 739.0 MHz

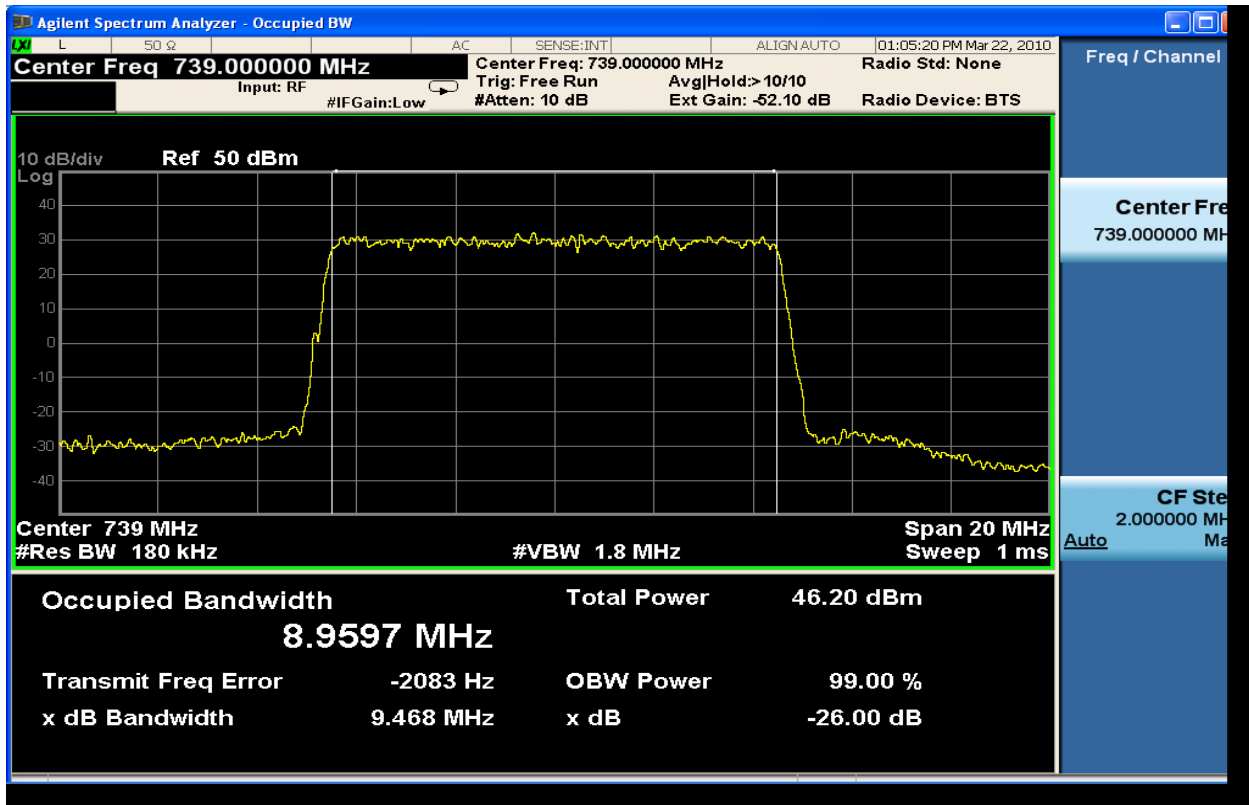

Figure 6-145: 10MHz Occupied Bandwidth TX1\_64QAM at 739.0 MHz

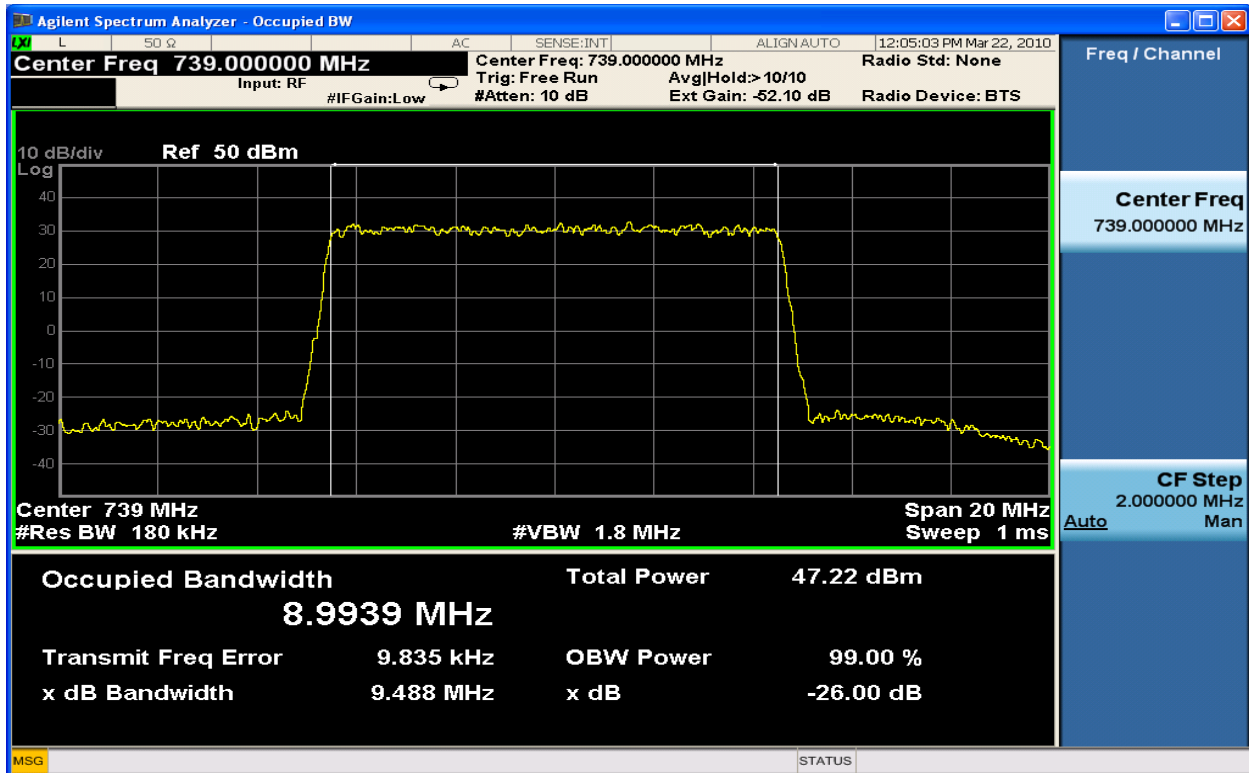

Figure 6-146: 10MHz Occupied Bandwidth TX2\_64QAM at 739.0 MHz

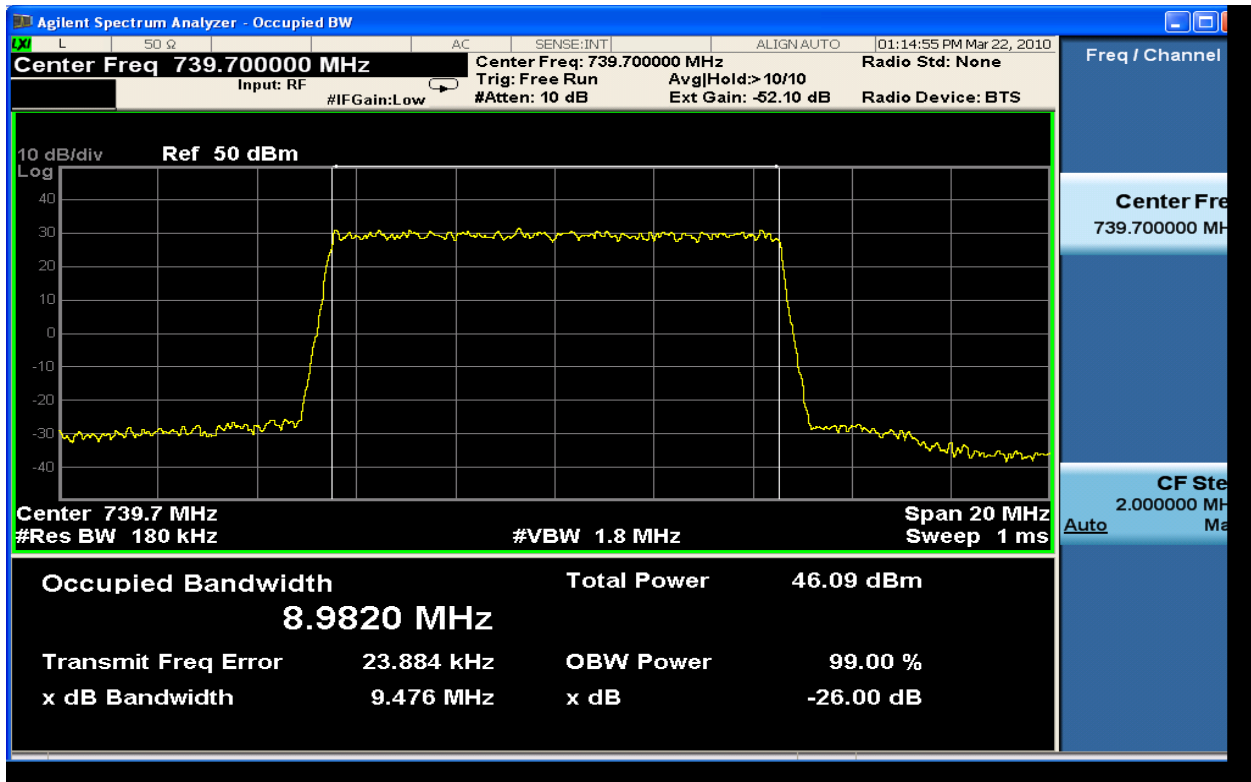

Figure 6-147: 10MHz Occupied Bandwidth TX1\_QPSK at 739.7 MHz

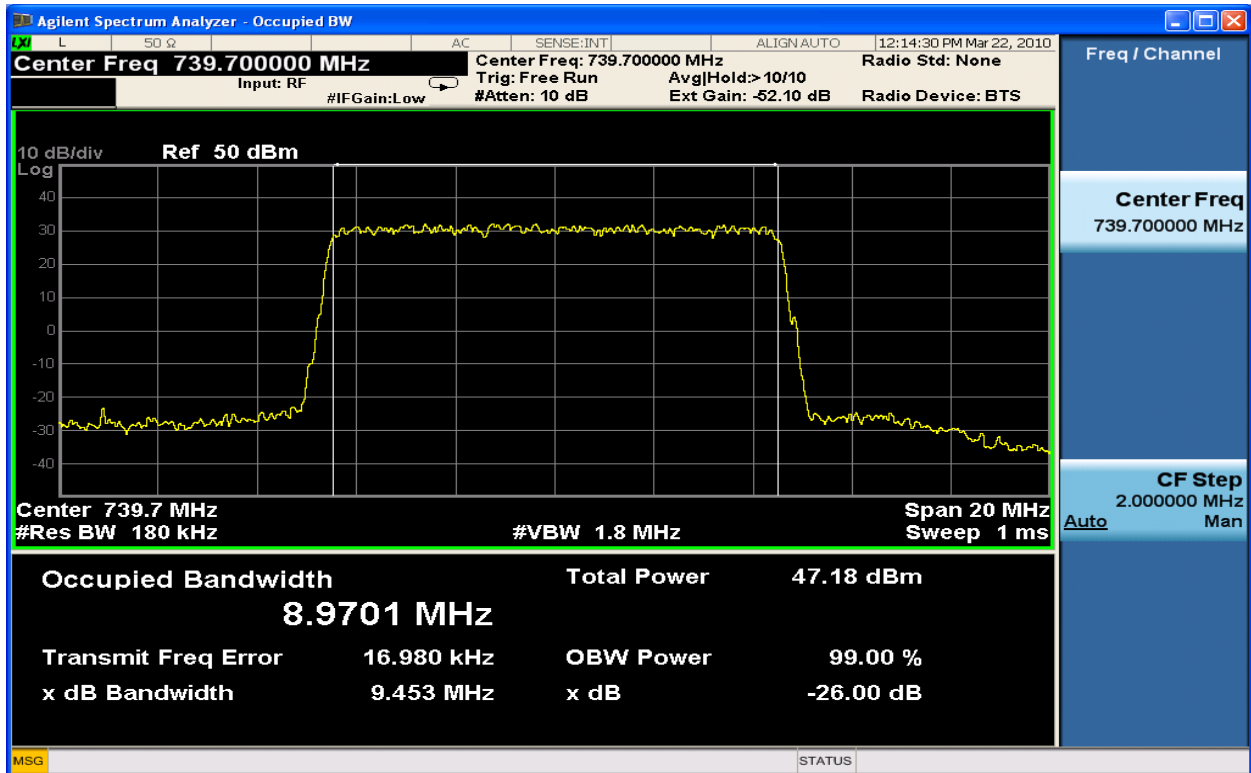

Figure 6-148: 10MHz Occupied Bandwidth TX2\_QPSK at 739.7 MHz

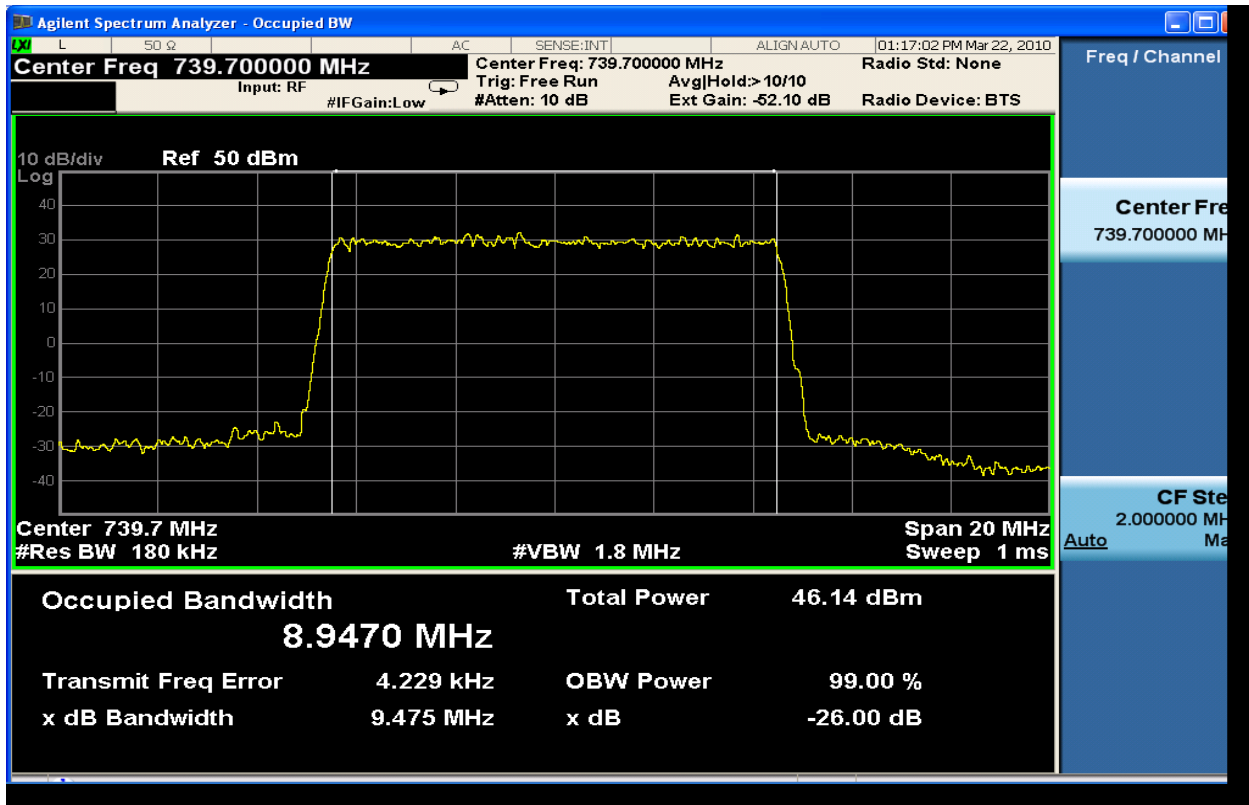

Figure 6-149: 10MHz Occupied Bandwidth TX1\_16QAM at 739.7 MHz

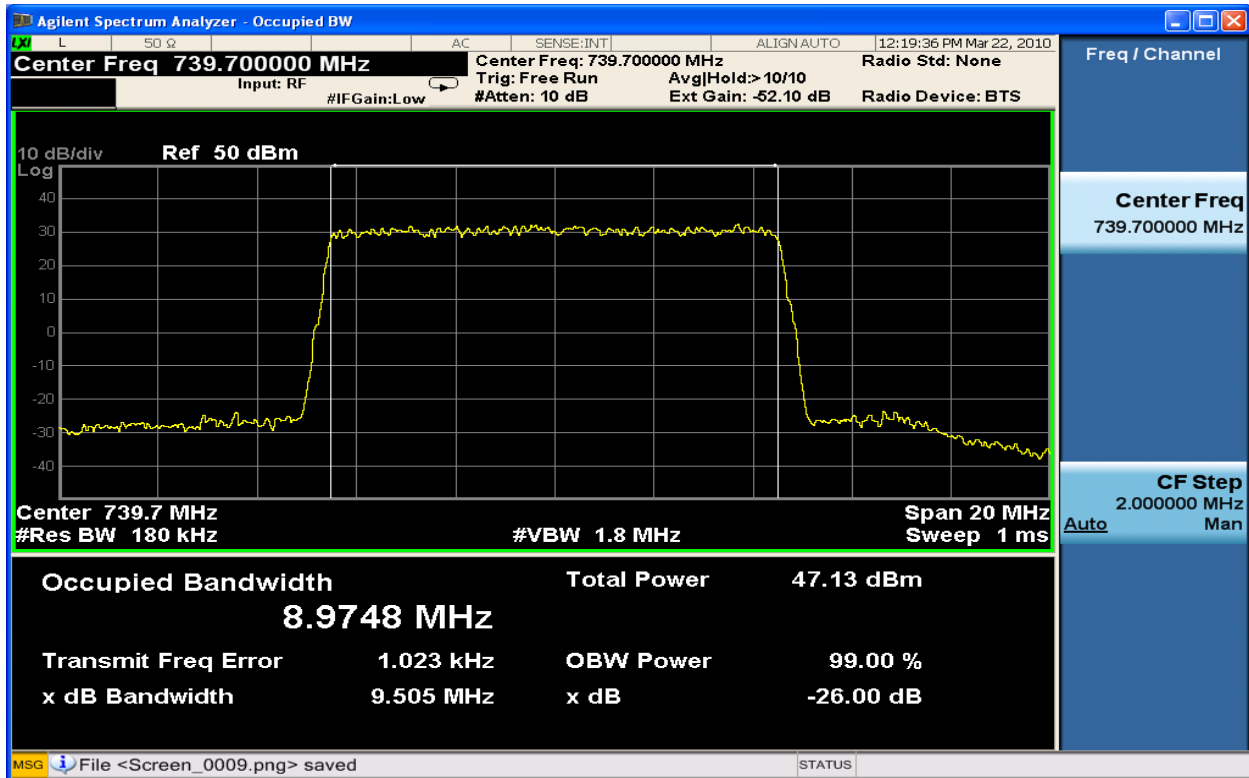

Figure 6-150: 10MHz Occupied Bandwidth TX2\_16QAM at 739.7 MHz



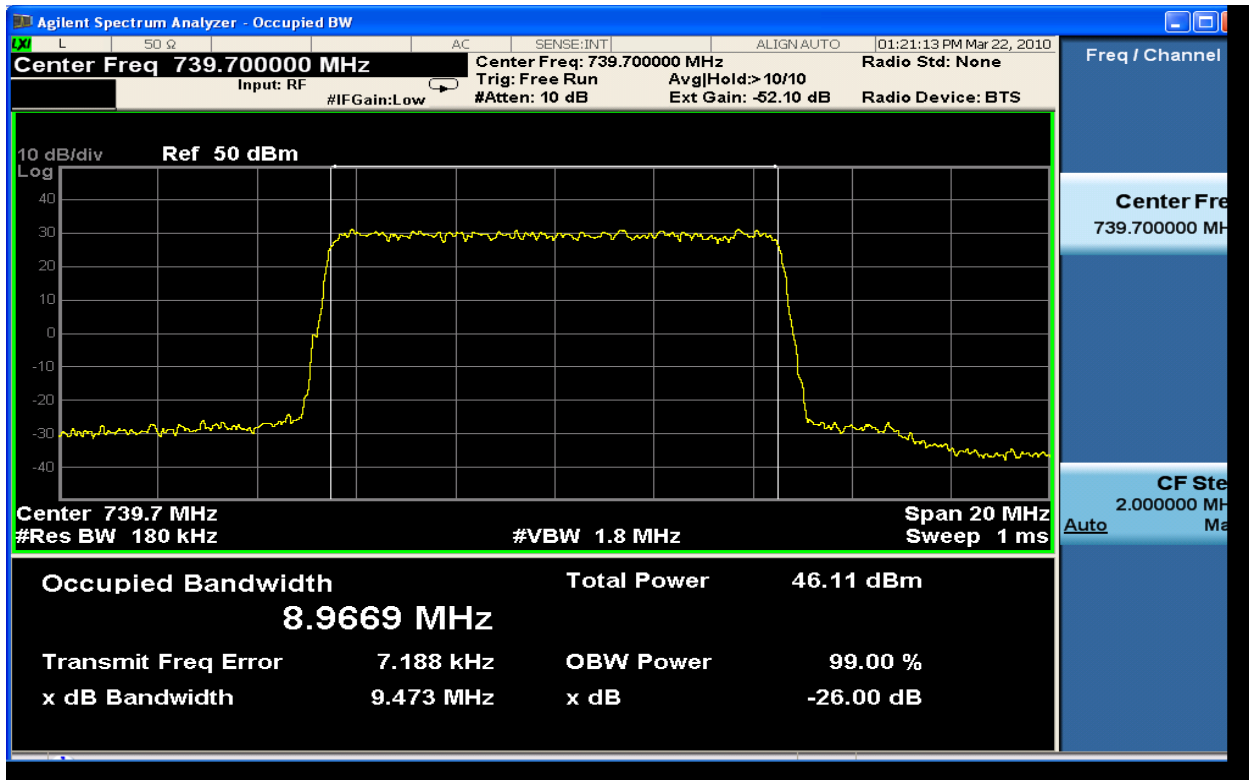

Figure 6-151: 10MHz Occupied Bandwidth TX1\_64QAM at 739.7 MHz

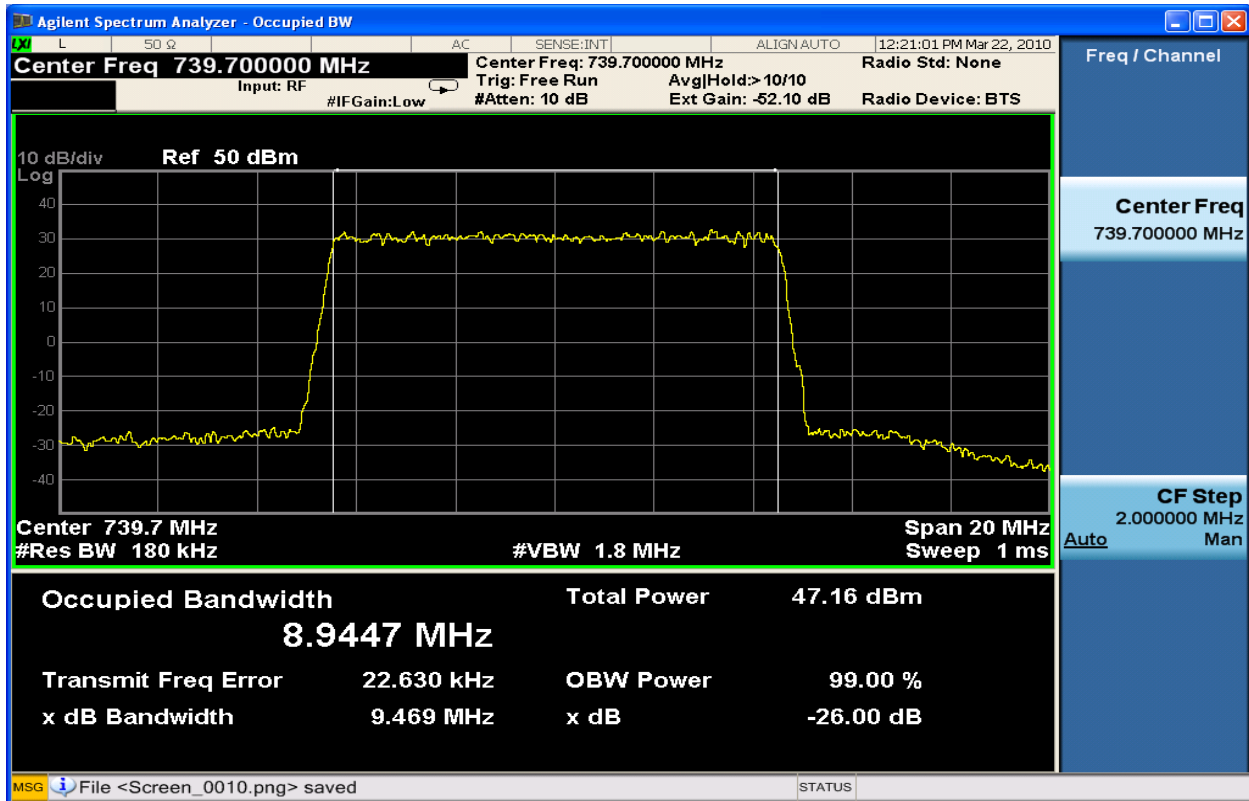

Figure 6-152: 10MHz Occupied Bandwidth TX2\_64QAM at 739.7 MHz

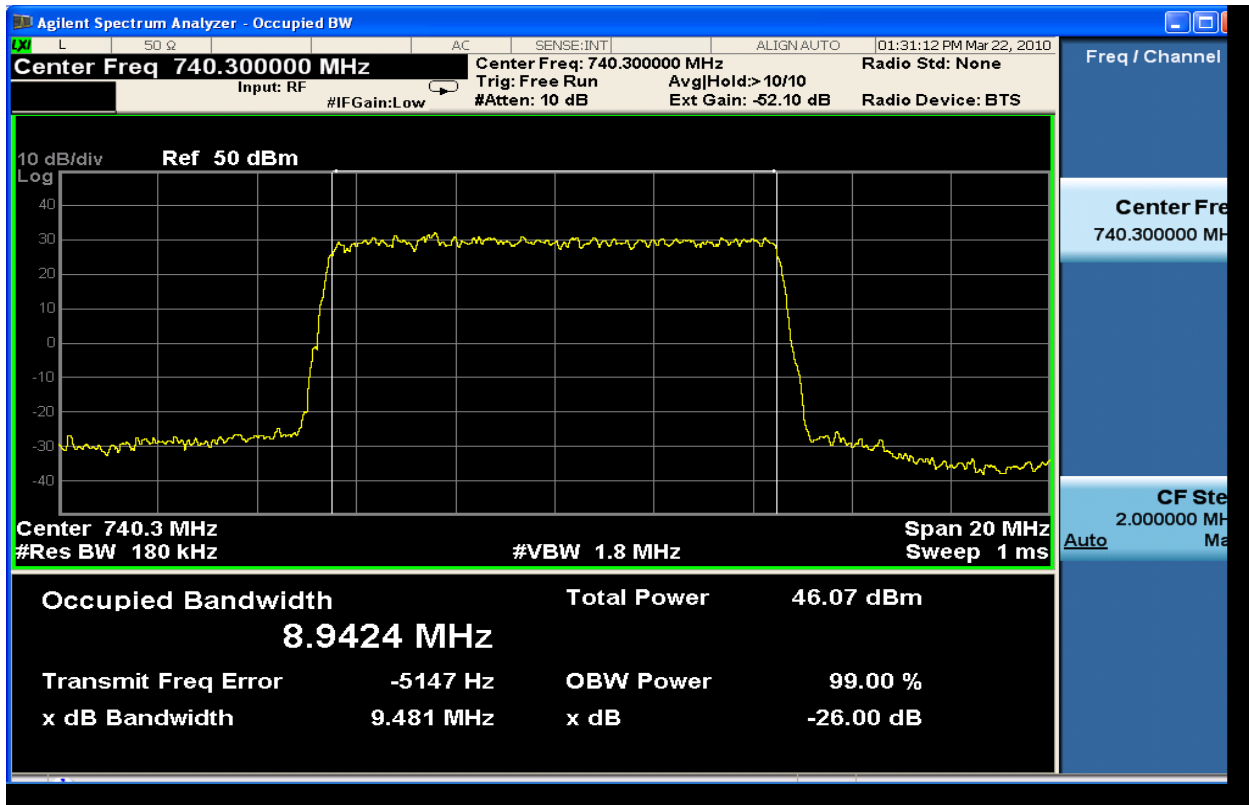

Figure 6-153: 10MHz Occupied Bandwidth TX1\_QPSK at 740.3 MHz

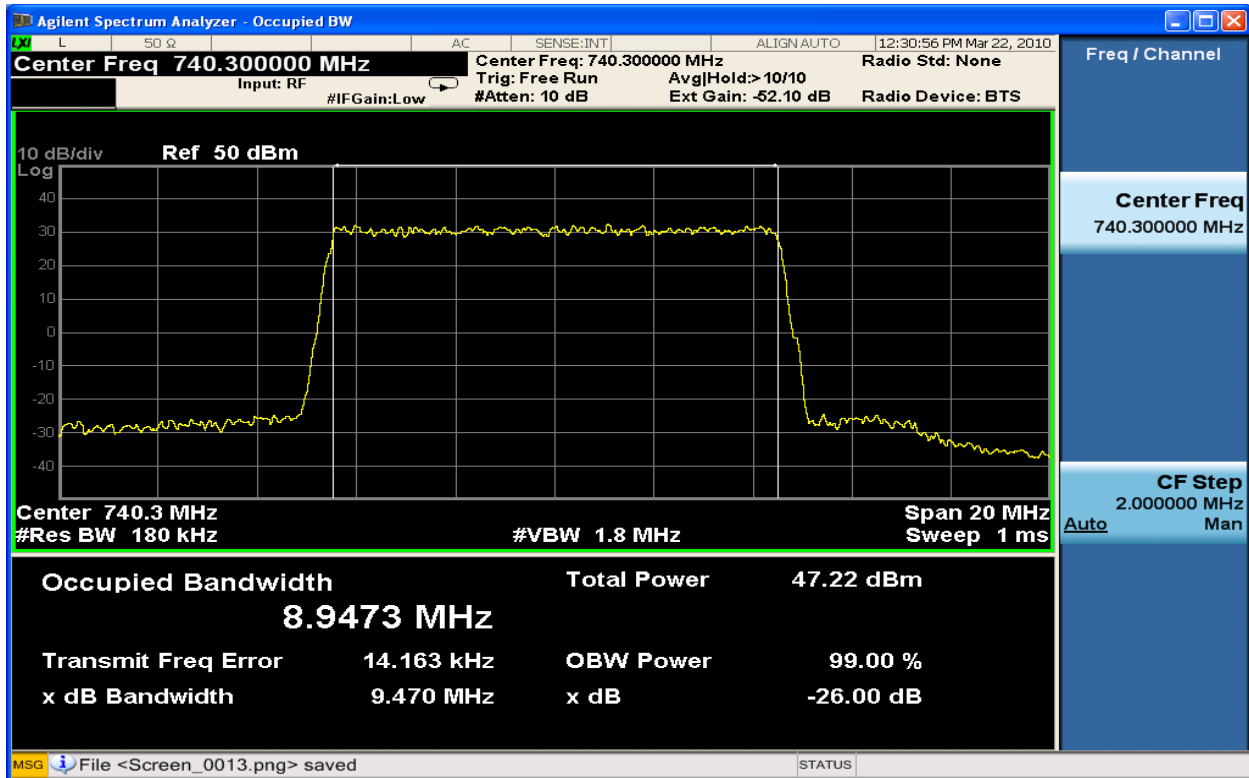

Figure 6-154: 10MHz Occupied Bandwidth TX2\_QPSK at 740.3 MHz

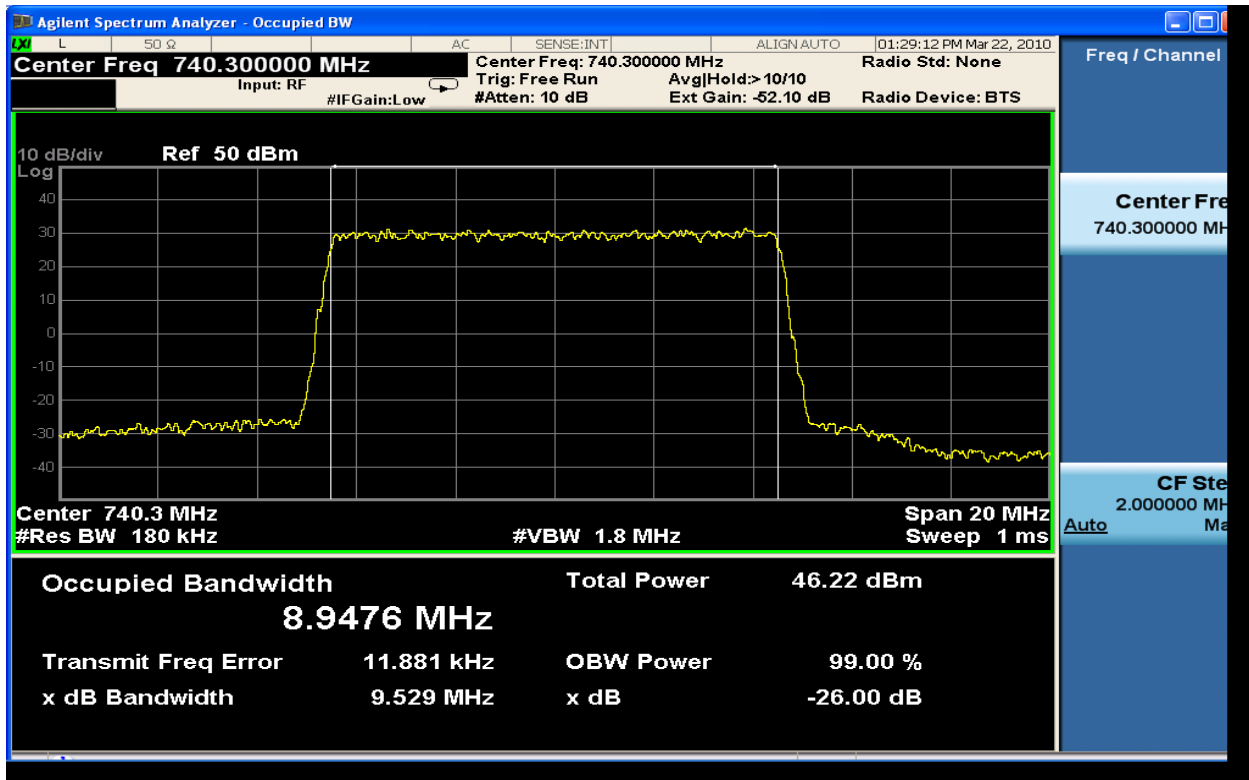

Figure 6-155: 10MHz Occupied Bandwidth TX1\_16QAM at 740.3 MHz

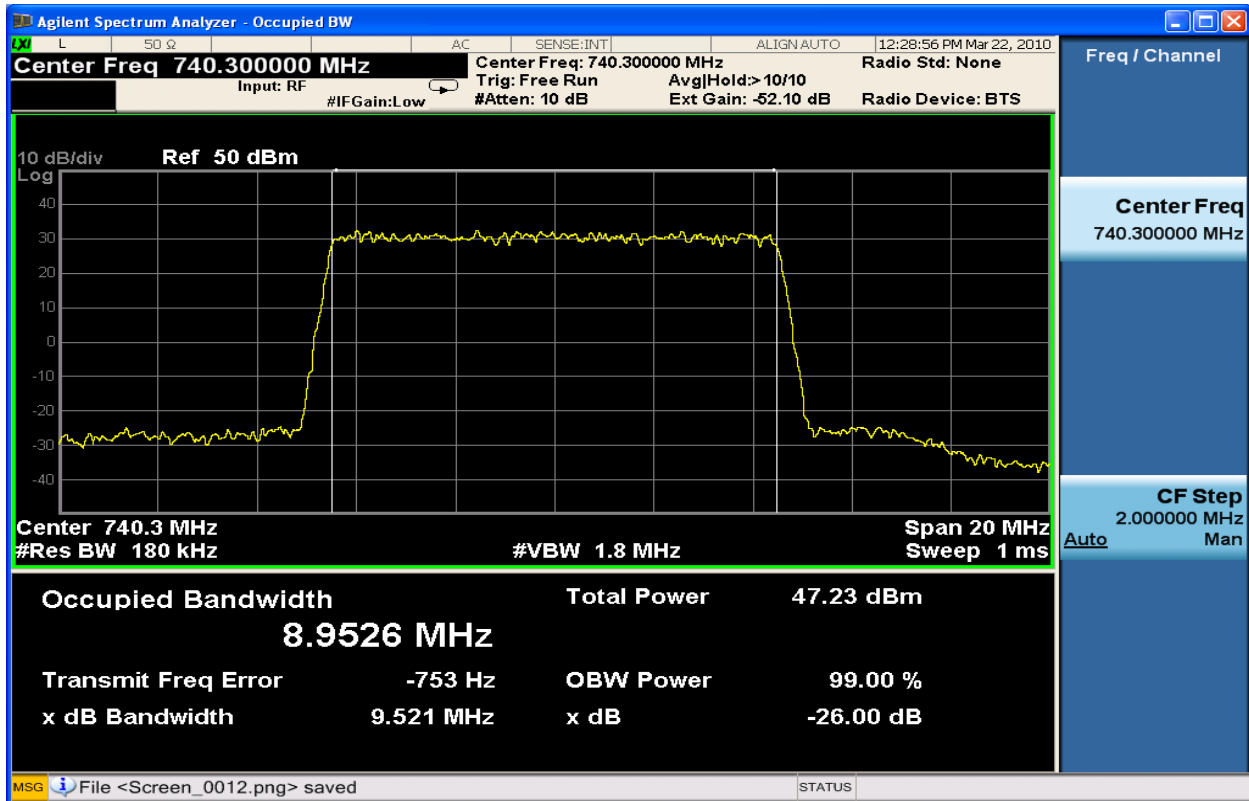

Figure 6-156: 10MHz Occupied Bandwidth TX2\_16QAM at 740.3 MHz

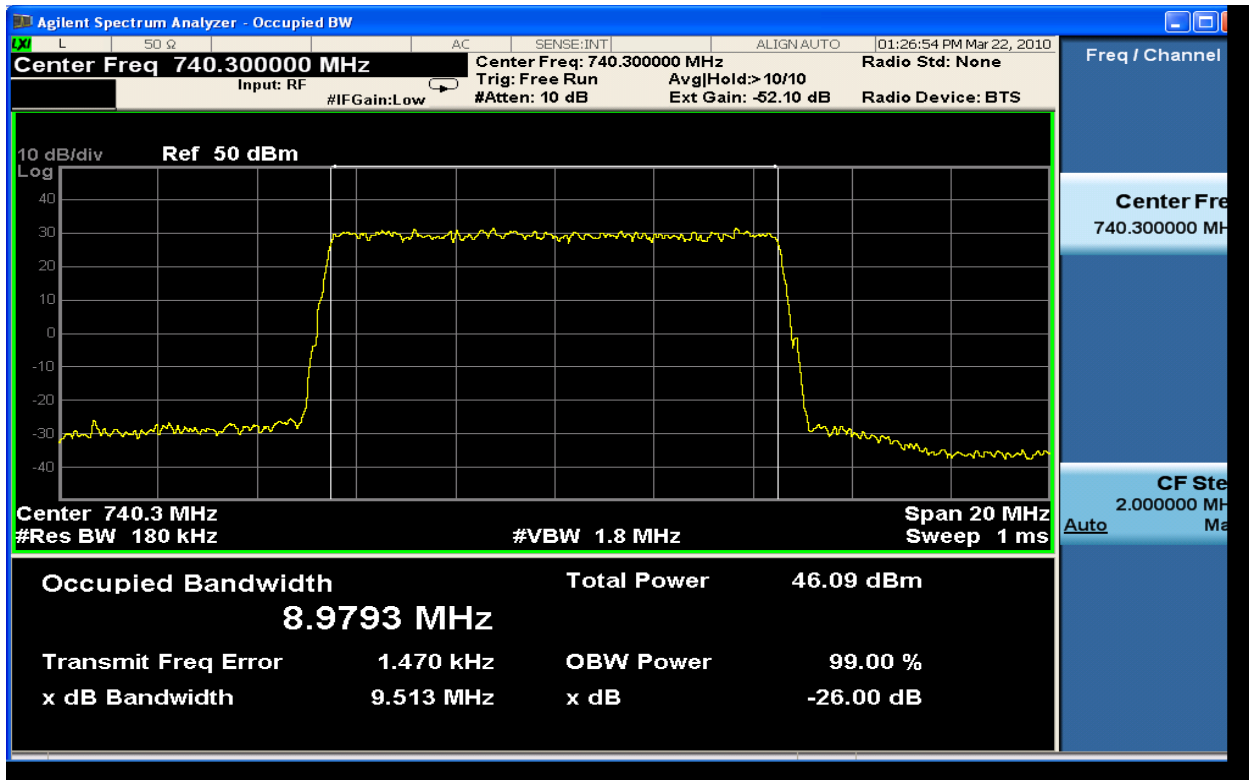

Figure 6-157: 10MHz Occupied Bandwidth TX1\_64QAM at 740.3 MHz

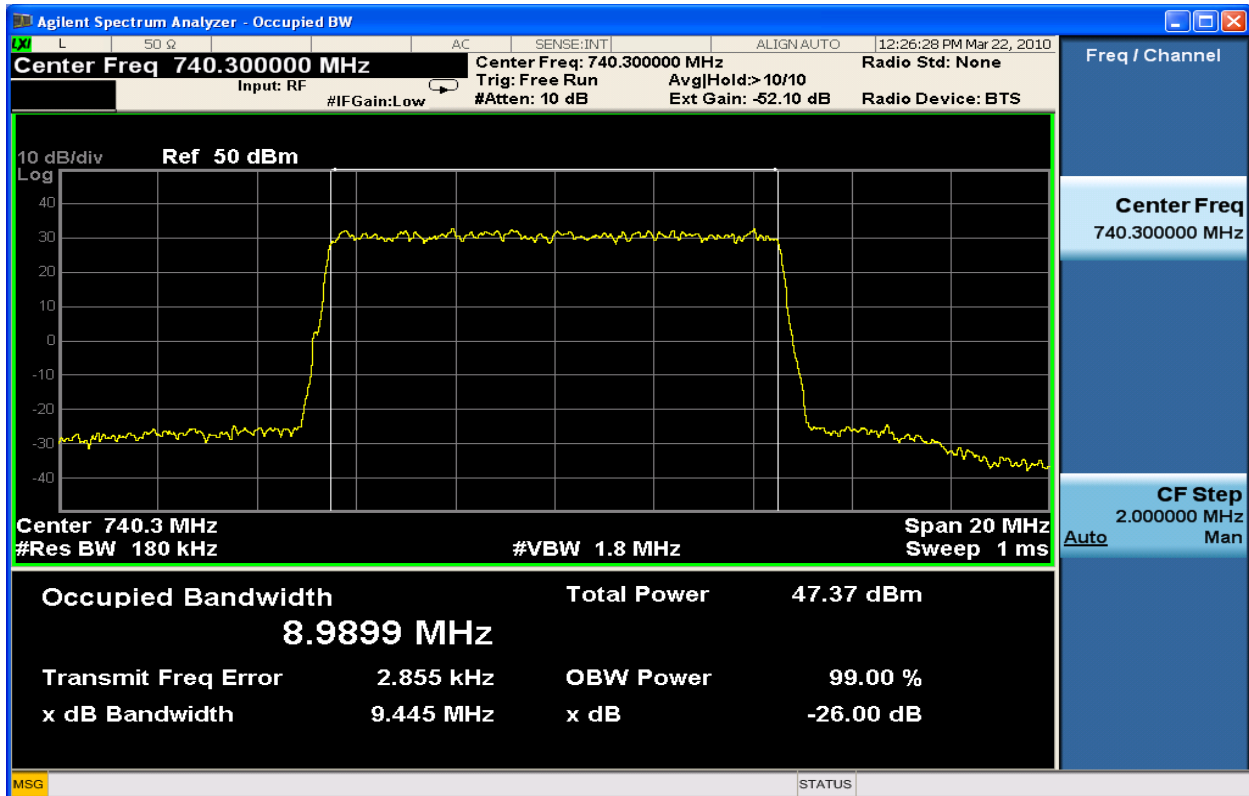

Figure 6-158: 10MHz Occupied Bandwidth TX2\_64QAM at 740.3 MHz

## 6.4 Spurious Emissions at the Antenna Terminal

Clause 27.53(g) 2.1051

(g) For operations in the 698–746 MHz band, the power of any emission outside a licensee’s frequency band(s) of operation shall be attenuated below the transmitter power (P) within the licensed band(s) of operation, measured in watts, by at least  $43 + 10 \log (P)$  dB. Compliance with this provision is based on the use of measurement instrumentation employing a resolution bandwidth of 100 kilohertz or greater. However, in the 100 kilohertz bands immediately outside and adjacent to a licensee’s frequency block, a resolution bandwidth of at least 30 kHz may be employed.

### Test Setup:

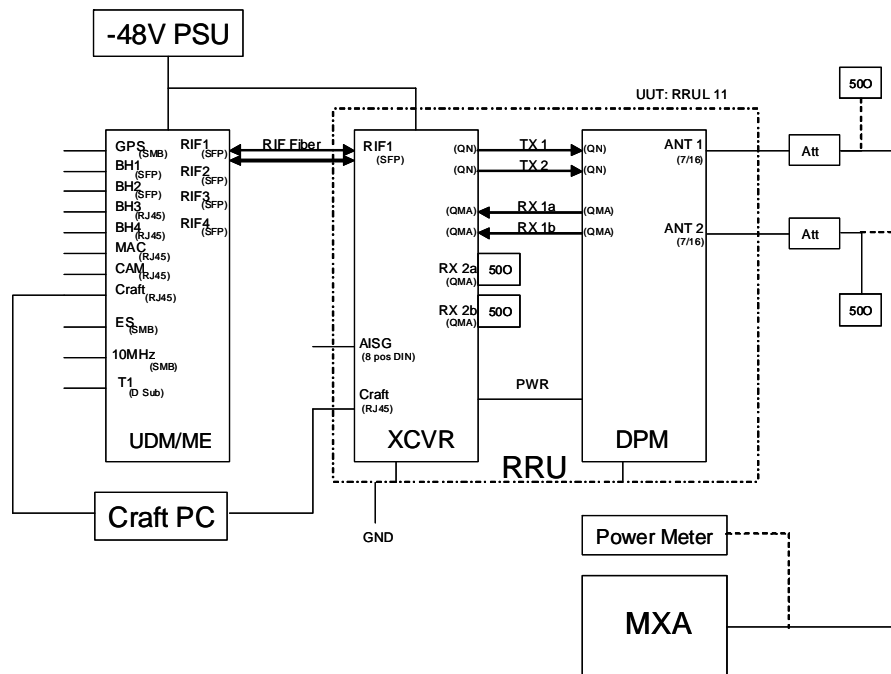

Figure 6-159 RRU Radio Compliance Set Up / Configuration

FCC Section 27.53(g):

On any frequency outside the 698 - 746 MHz band, the power of any emission shall be attenuated outside the band below the transmitter power (P) by at least  $43 + 10 \log (P)$  dB;

$$\text{FCC Limit} = \text{PWR (dBm)} - [ 43 + 10\log(\text{PWR (w)}) ] = 44.8 - 43 + 10\log(30) = -13\text{dBm}$$

### Procedure:

The following procedure and conditions shall apply for Spurious Emission measurements. As applicable, lower and high side offsets from the channel shall be assessed with respect to all modulation, and bandwidths as well as all emissions up to 8.5GHz. Results shall be compiled and recorded along with the relevant captured plots.

**Table 6-5: Setting / Measurement Results – Spurious Emissions Band Edge BW = 5MHz**

Setting Measurement ACP < 2MHz		Spurious Emissions (dBm) FCC Limit -13dBm					
		QPSK		16 QAM		64 QAM	
		TX1	TX2	TX1	TX2	TX1	TX2
		<b>Lower Edge Emission</b>					
Frequency (A Block CH_5035)	731.5MHz	-24.86	-26.82	-25.05	-26.07	-24.48	-26.47
Frequency (Lower B CH_5085)	736.5MHz	-26.38	-27.30	-26.64	-25.01	-25.73	-26.90
Frequency (Upper B CH_5095)	737.5MHz	-26.94	-27.77	-26.47	-27.04	-26.18	-26.86
Frequency (C Block CH_5145)	742.5MHz	-26.40	-25.16	-26.13	-26.01	-26.07	-26.55
		<b>Upper Edge Emission</b>					
Frequency (A Block CH_5035)	731.5MHz	-26.10	-27.17	-26.25	-26.77	-26.37	-26.58
Frequency (Lower B CH_5085)	736.5MHz	-29.59	-29.74	-29.49	-28.28	-29.96	-29.74
Frequency (Upper B CH_5095)	737.5MHz	-30.33	-30.57	-30.40	-29.92	-30.31	-30.39
Frequency (C Block CH_5145)	742.5MHz	-30.03	-29.50	-29.53	-29.47	-30.00	-30.01
RBW	30kHz						
VBW	30kHz						
CH BW	5MHz	<b>Lower Margin to FCC Limit (dB)</b>					
Reference Level Offset	52.1dB	11.86	12.16	12.05	12.01	11.48	13.47
Detector	RMS	<b>Upper Margin to FCC Limit (dB)</b>					
Attenuation	6dB	13.10	14.17	13.25	13.77	13.37	13.58

**Table 6-6: Setting / Measurement Results – Spurious Emissions Band Edge BW = 10MHz**

Setting Measurement ACP < 2MHz		Spurious Emissions (dBm) FCC Limit -13dBm					
		QPSK		16 QAM		64 QAM	
		TX1	TX2	TX1	TX2	TX1	TX2
		<b>Lower Edge Emission</b>					
Frequency (Lower AB CH_5057)	733.7MHz	-29.70	-30.38	-28.77	-30.54	-29.14	-30.38
Frequency (Upper AB CH_5070)	735.0MHz	-30.24	-30.42	-29.51	-29.11	-30.18	-30.73
Frequency (Lower BC CH_5110)	739.0MHz	-29.89	-30.32	-29.46	-30.52	-29.86	-30.70
Frequency (Upper BC CH_5123)	740.3MHz	-29.63	-31.03	-29.59	-30.14	-30.14	-30.50
		<b>Upper Edge Emission</b>					
Frequency (Lower AB CH_5057)	733.7MHz	-30.08	-29.81	-29.95	-29.49	-30.00	-29.04
Frequency (Upper AB CH_5070)	735.0MHz	-30.96	-30.03	-30.56	-28.54	-30.73	-29.75
Frequency (Lower BC CH_5110)	739.0MHz	-31.66	-30.89	-31.73	-30.29	-30.20	-31.16
Frequency (Upper BC CH_5123)	740.3MHz	-31.58	-31.70	-32.21	-31.18	-32.08	-30.75
RBW	30kHz						
VBW	30kHz						
CH BW	10MHz	<b>Lower Margin to FCC Limit (dB)</b>					
Reference Level Offset	52.1dB	16.63	17.32	15.77	16.11	16.14	17.38
Detector	RMS	<b>Upper Margin to FCC Limit (dB)</b>					
Attenuation	6dB	17.08	16.81	16.95	15.54	17.00	16.04

**Table 6-7: Setting / Measurement Results – BW = 5MHz, Spurious Emissions <1GHz**

Setting Measurement < 1GHz		Spurious Emissions (dBm) FCC Limit -13dBm					
		QPSK		16 QAM		64 QAM	
		TX1	TX2	TX1	TX2	TX1	TX2
Frequency (Block A CH_5035)	731.5MHz	-36.48	-36.81	-35.40	-39.03	-34.97	-38.02
Frequency (Block B CH_5090)	737.0MHz	-36.01	-36.99	-36.16	-37.25	-36.27	-35.36
Frequency (Block C CH_5145)	742.5MHz	-34.85	-38.15	-36.02	-35.65	-37.19	-36.91
RBW	100kHz						
VBW	300kHz						
CH BW	5MHz						
Reference Level Offset	52.1dB						
Detector	RMS	<b>Margin to FCC Limit (dB)</b>					
Attenuation	6dB	21.85	23.81	22.40	22.65	21.97	22.36

**Table 6-8: Setting / Measurement Results – BW = 5MHz, Spurious Emissions > 1GHz**

Setting Measurement > 1GHz		Spurious Emissions (dBm) FCC Limit -13dBm					
		QPSK		16 QAM		64 QAM	
		TX1	TX2	TX1	TX2	TX1	TX2
Frequency (Block A CH_5035)	731.5MHz	-19.83	-20.37	-20.02	-20.37	-19.68	-18.84
Frequency (Block B CH_5090)	737.0MHz	-20.16	-20.91	-21.01	-19.78	-20.18	-18.39
Frequency (Block C CH_5145)	742.5MHz	-19.81	-20.89	-20.62	-21.28	-19.63	-18.61
RBW	1MHz						
VBW	3MHz						
CH BW	5MHz						
Reference Level Offset	52.1dB						
Detector	RMS	<b>Margin to FCC Limit (dB)</b>					
Attenuation	6dB	6.81	7.37	7.02	6.78	6.63	5.39

**Table 6-9: Setting / Measurement Results – BW = 10MHz, Spurious Emissions <1GHz**

Setting Measurement < 1GHz		Spurious Emissions (dBm) FCC Limit -13dBm					
		QPSK		16 QAM		64 QAM	
		TX1	TX2	TX1	TX2	TX1	TX2
Frequency (Block AB CH_5057)	733.7MHz	-36.76	-36.91	-35.28	-38.45	-36.41	-38.93
Frequency (Block ABC CH_5090)	737.0MHz	-33.99	-37.86	-36.30	-36.17	-37.80	-38.00
Frequency (Block BC CH_5123)	740.3MHz	-38.21	-39.17	-37.47	-38.19	-37.50	-38.63
RBW	100kHz						
VBW	300kHz						
CH BW	5MHz						
Reference Level Offset	52.1dB						
Detector	RMS	<b>Margin to FCC Limit (dB)</b>					
Attenuation	6dB	20.99	23.91	22.28	23.17	23.41	25.00

**Table 6-10: Setting / Measurement Results – BW = 10MHz, Spurious Emissions > 1GHz**

Setting Measurement > 1GHz		Spurious Emissions (dBm) FCC Limit -13dBm					
		QPSK		16 QAM		64 QAM	
		TX1	TX2	TX1	TX2	TX1	TX2
Frequency (Block AB CH_5057)	733.7MHz	-20.10	-21.07	-20.33	-20.97	-19.34	-20.83
Frequency (Block ABC CH_5090)	737.0MHz	-20.56	-20.71	-19.68	-21.60	-20.90	-20.83
Frequency (Block BC CH_5123)	740.3MHz	-18.91	-18.57	-20.94	-21.04	-19.99	-20.48
RBW	1MHz						
VBW	3MHz						
CH BW	5MHz						
Reference Level Offset	52.1dB						
Detector	RMS	<b>Margin to FCC Limit (dB)</b>					
Attenuation	6dB	5.91	5.57	6.68	7.97	6.34	7.48



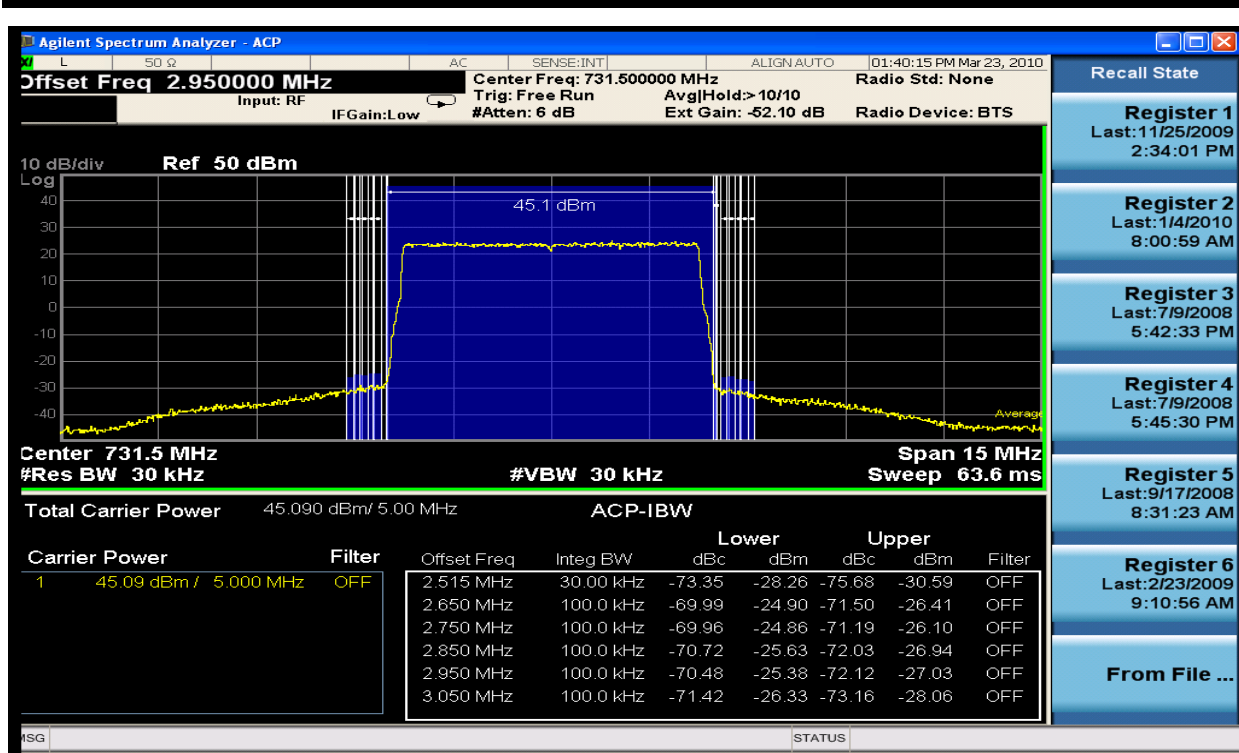

Figure 6-160 Spurious Emissions 731.5MHz TX1\_QPSK 5MHz Band Edge (ACP 15kHz – 550kHz)

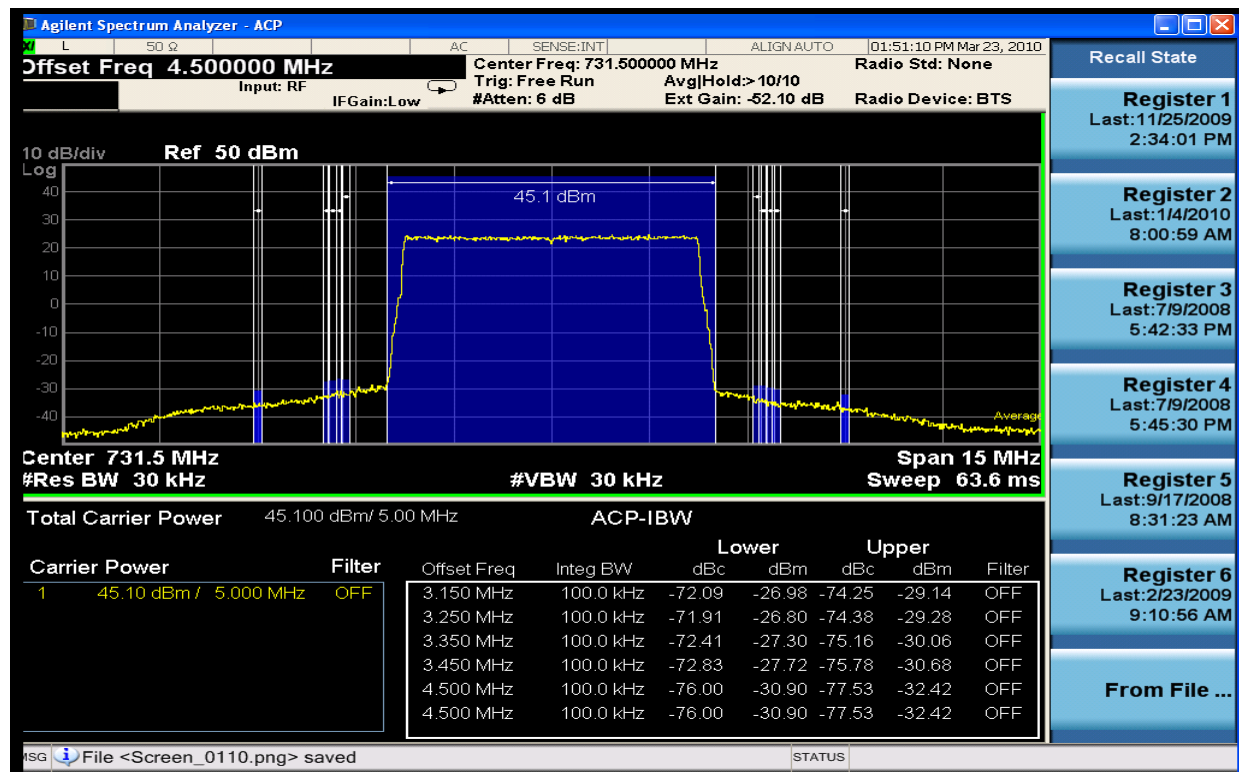

Figure 6-161 Spurious Emissions 731.5MHz TX1\_QPSK 5MHz Band Edge (ACP 650kHz – 2MHz)

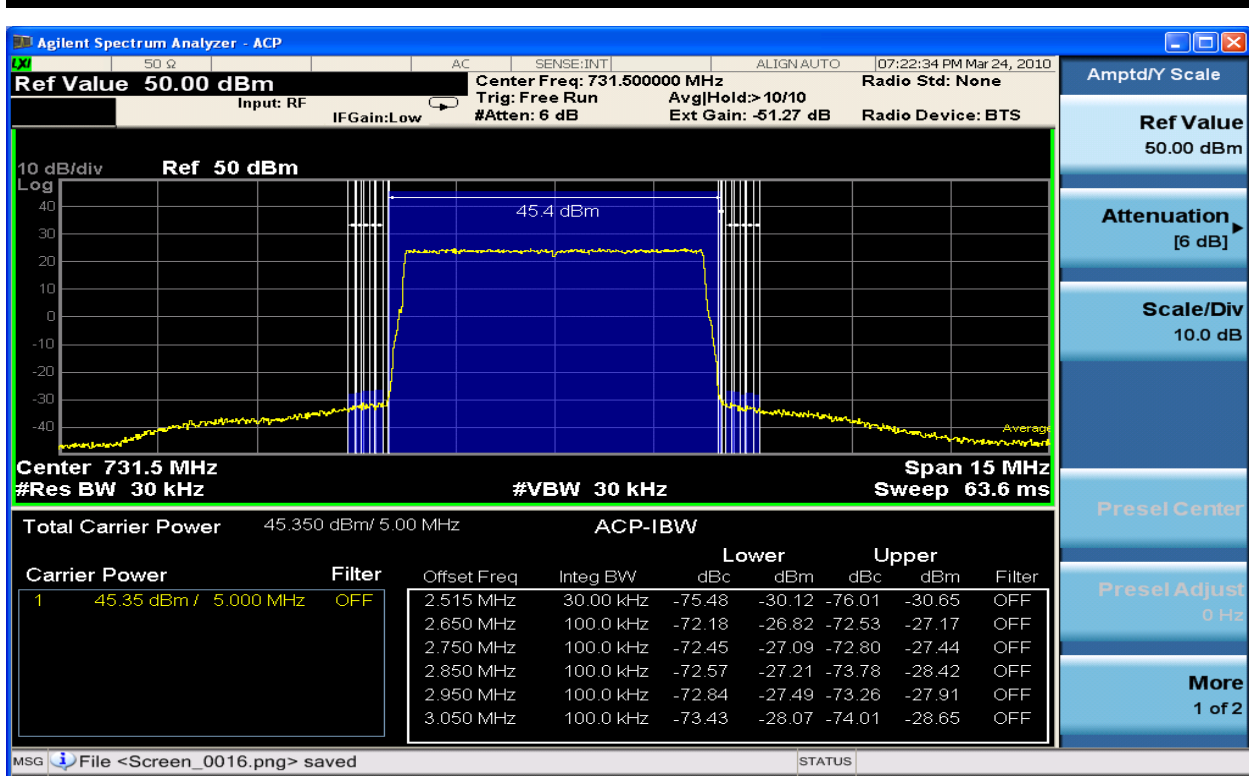

Figure 6-162 Spurious Emissions 731.5MHz TX2\_QPSK 5MHz Band Edge (ACP 15kHz – 550kHz)

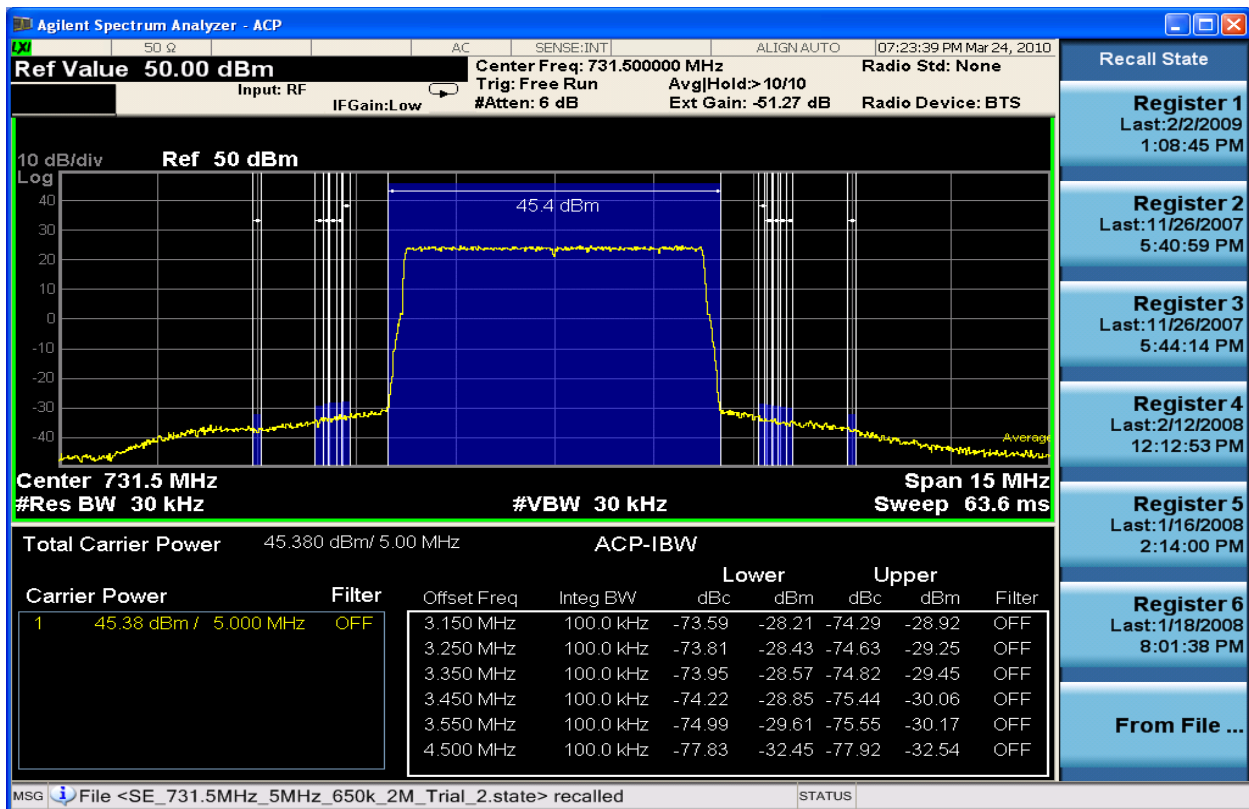

Figure 6-163 Spurious Emissions 731.5MHz TX2\_QPSK 5MHz Band Edge (ACP 650kHz – 2MHz)

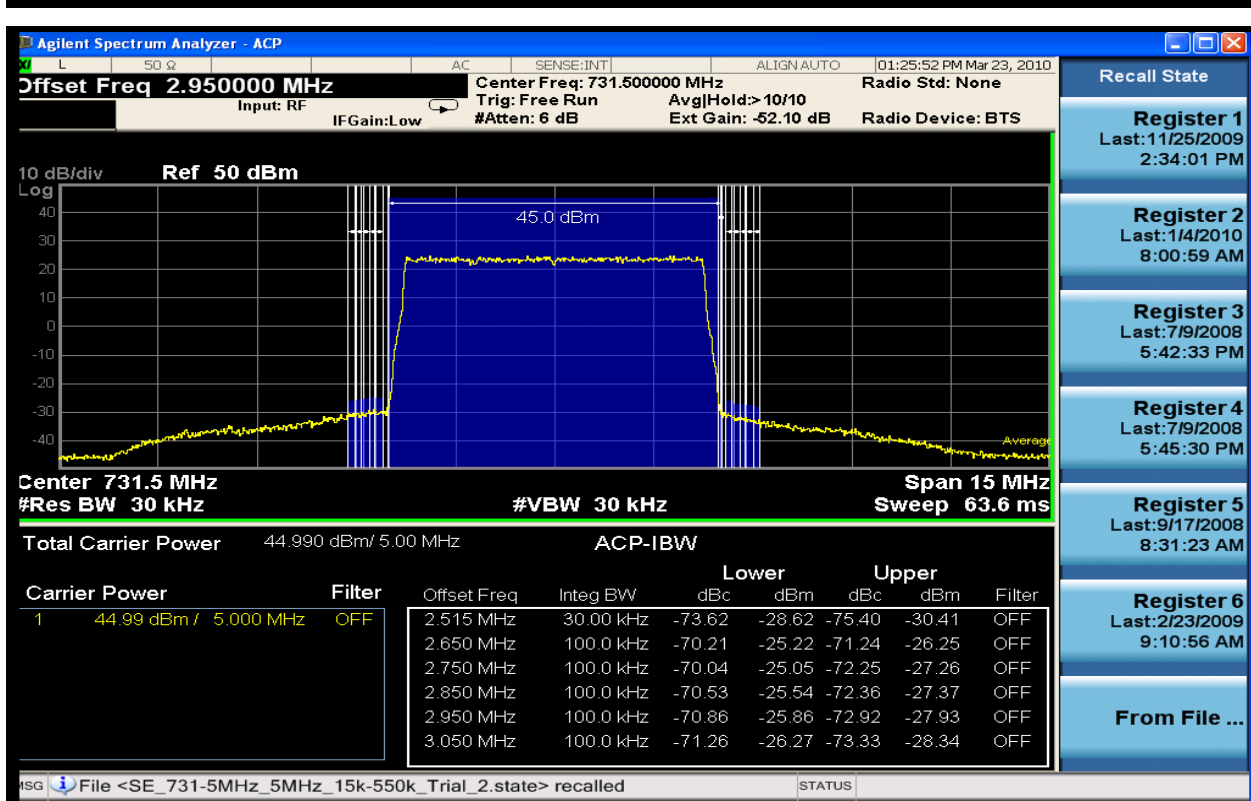

Figure 6-164 Spurious Emissions 731.5MHz TX1\_16QAM 5MHz Band Edge (ACP 15kHz – 550kHz)

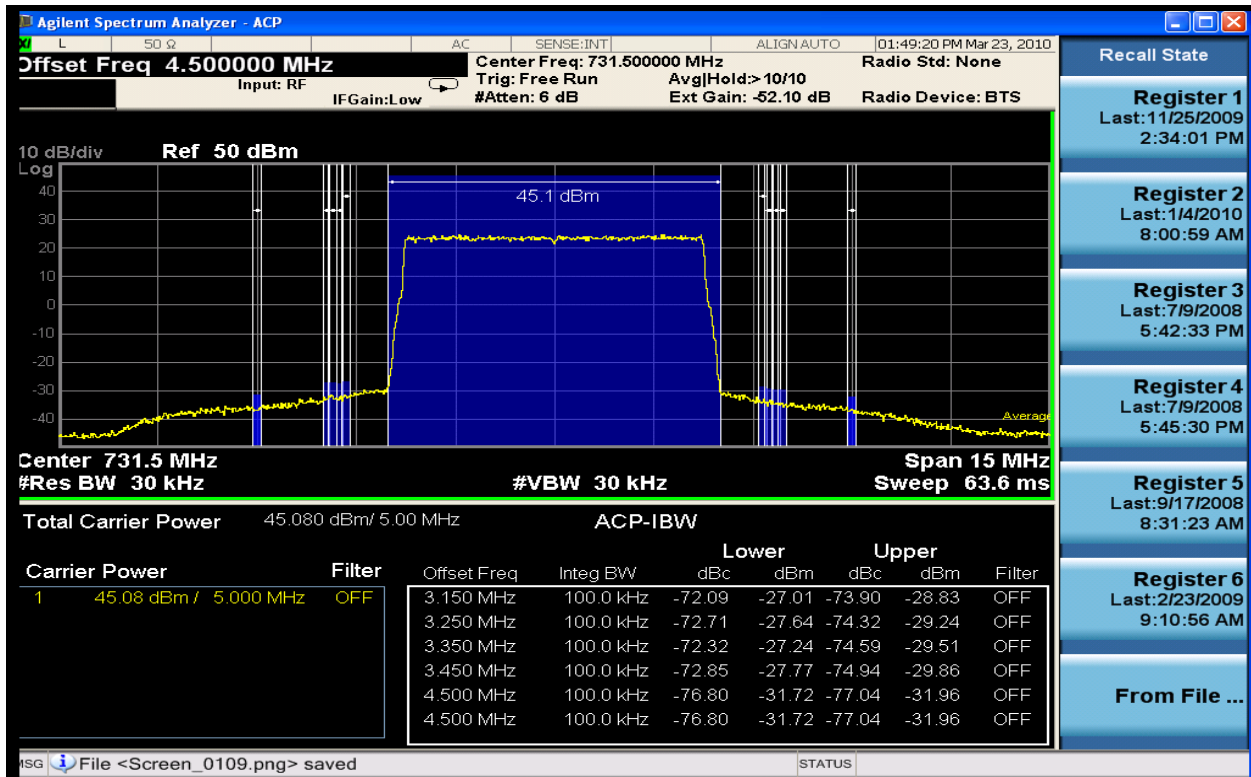

Figure 6-165 Spurious Emissions 731.5MHz TX1\_16QAM 5MHz Band Edge (ACP 650kHz – 2MHz)

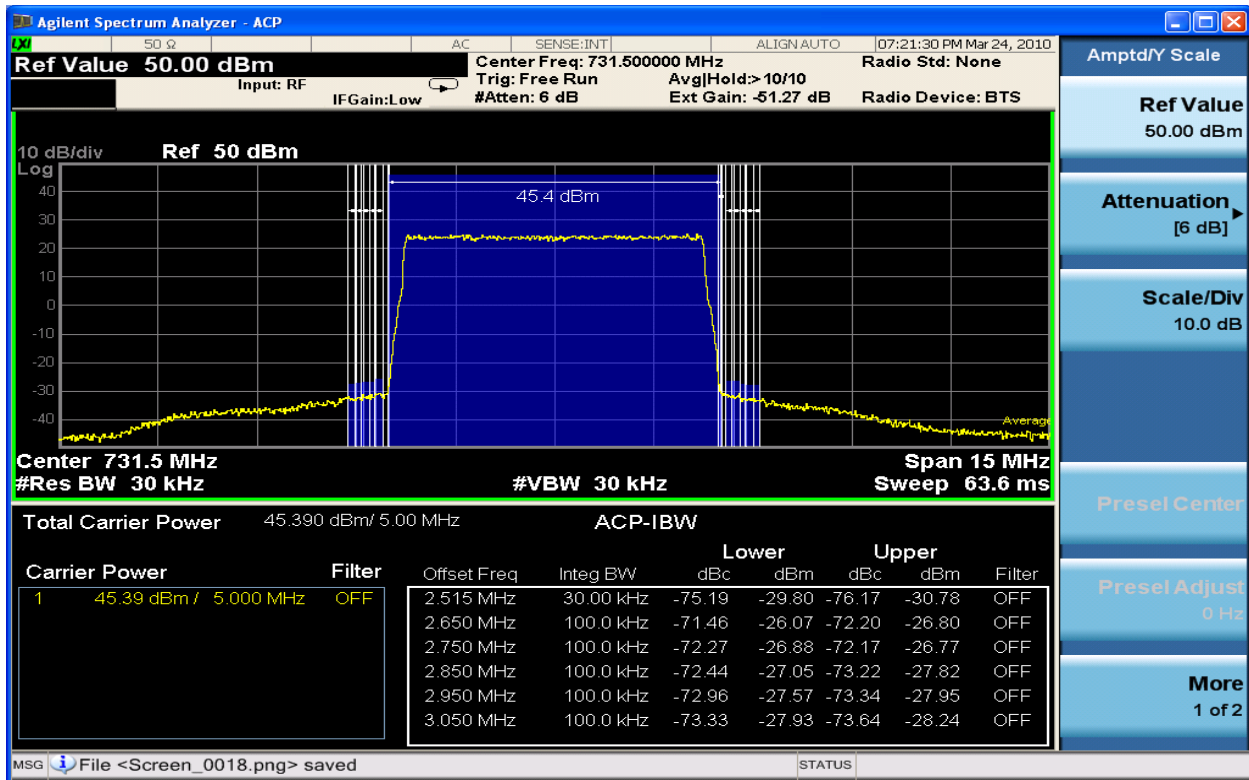

Figure 6-166 Spurious Emissions 731.5MHz TX2\_16QAM 5MHz Band Edge (ACP 15kHz – 550kHz)

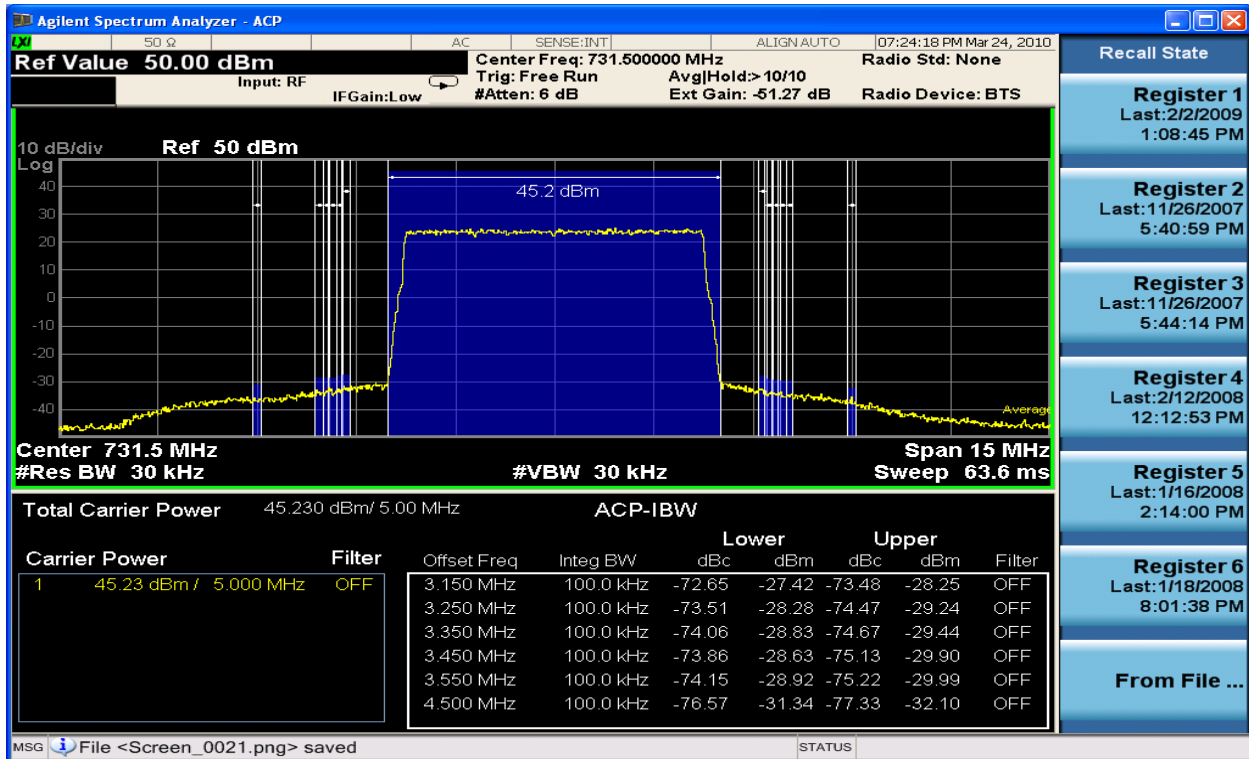

Figure 6-167 Spurious Emissions 731.5MHz TX2\_16QAM 5MHz Band Edge (ACP 650kHz – 2MHz)

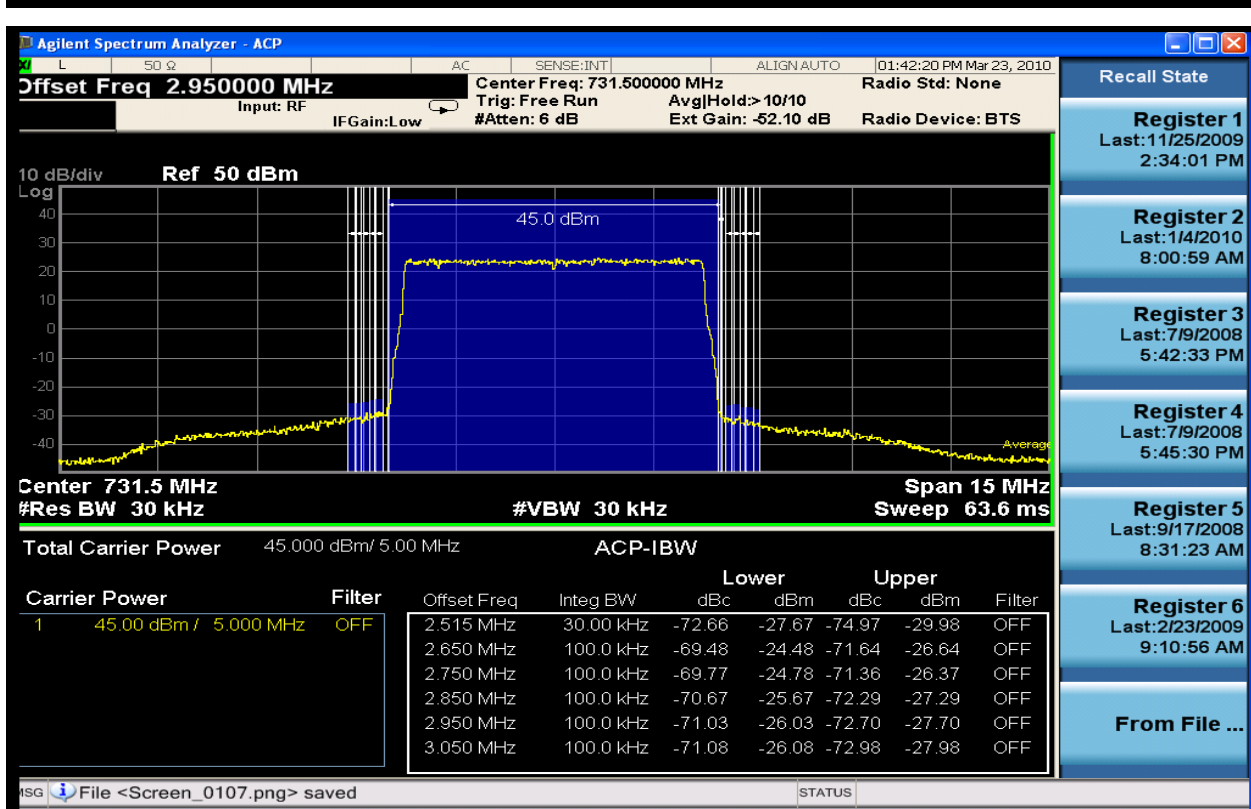

Figure 6-168 Spurious Emissions 731.5MHz TX1\_64QAM 5MHz Band Edge (ACP 15kHz – 550kHz)

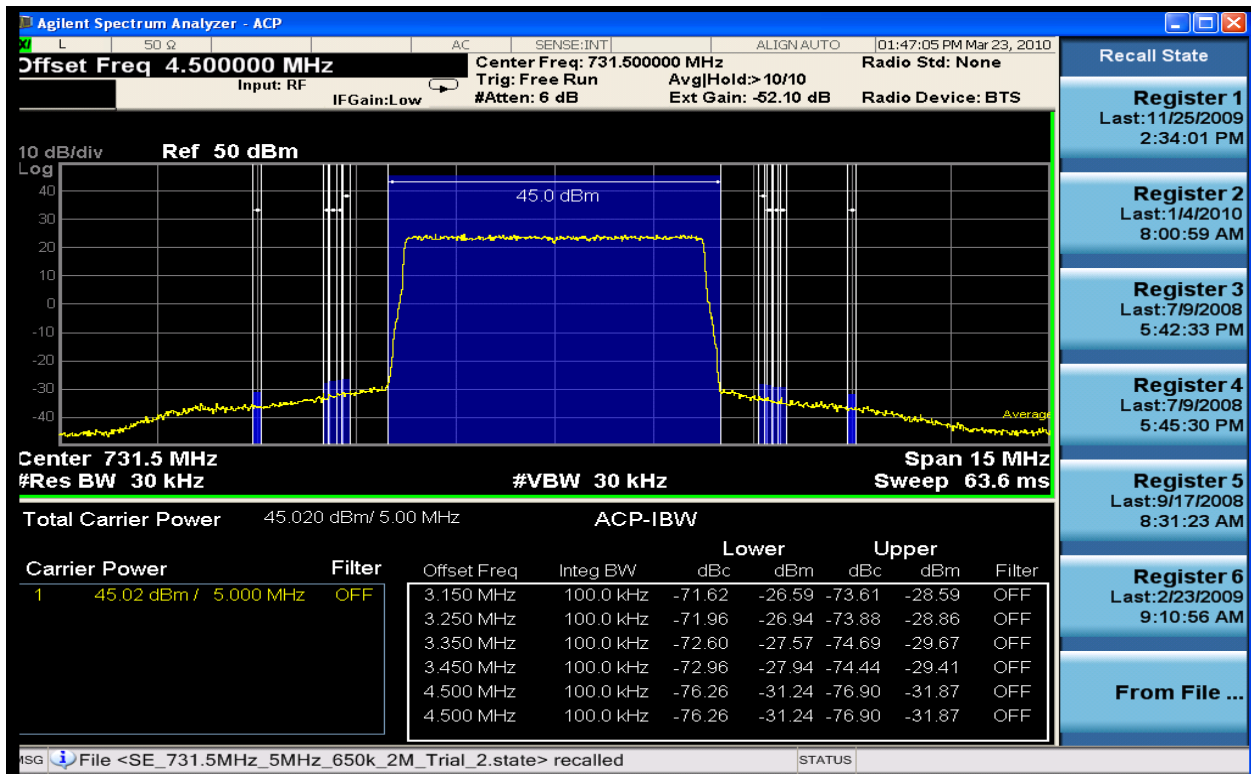

Figure 6-169 Spurious Emissions 731.5MHz TX1\_64QAM 5MHz Band Edge (ACP 650kHz – 2MHz)

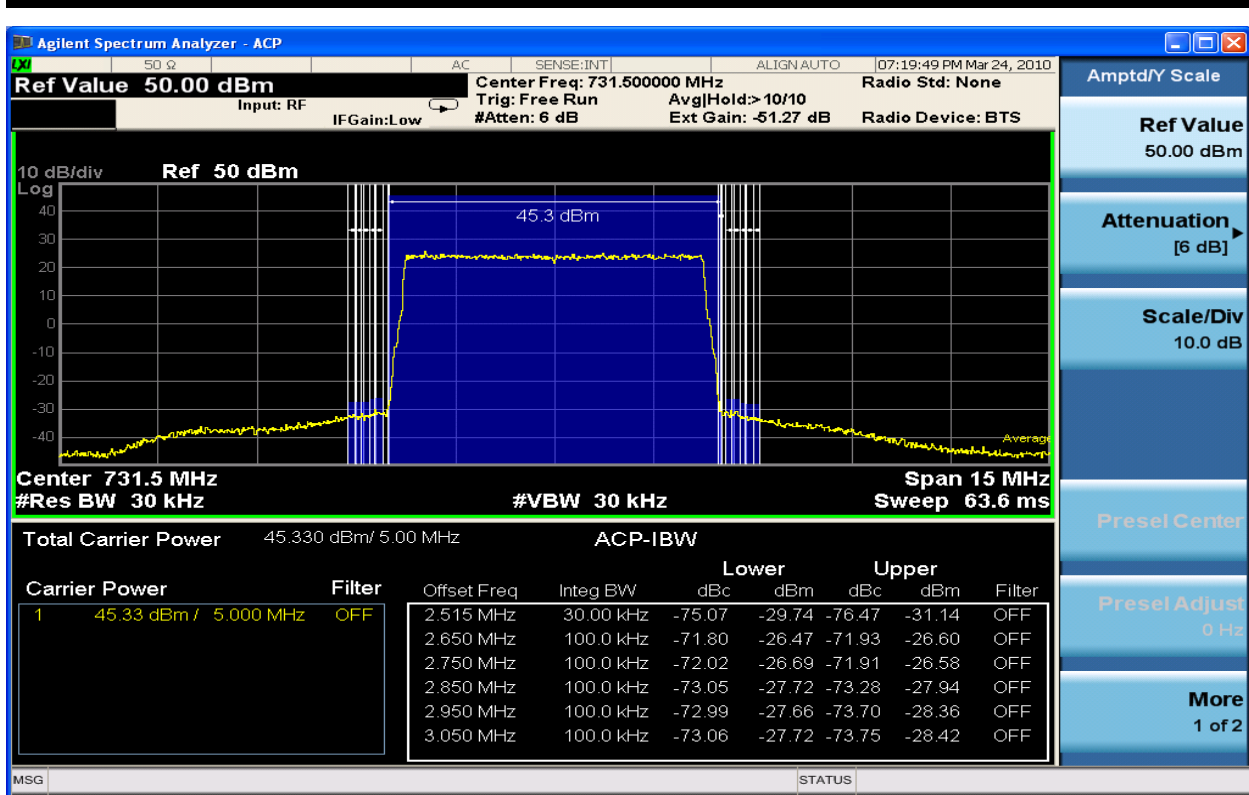

Figure 6-170 Spurious Emissions 731.5MHz TX2\_64QAM 5MHz Band Edge (ACP 15kHz -550kHz)

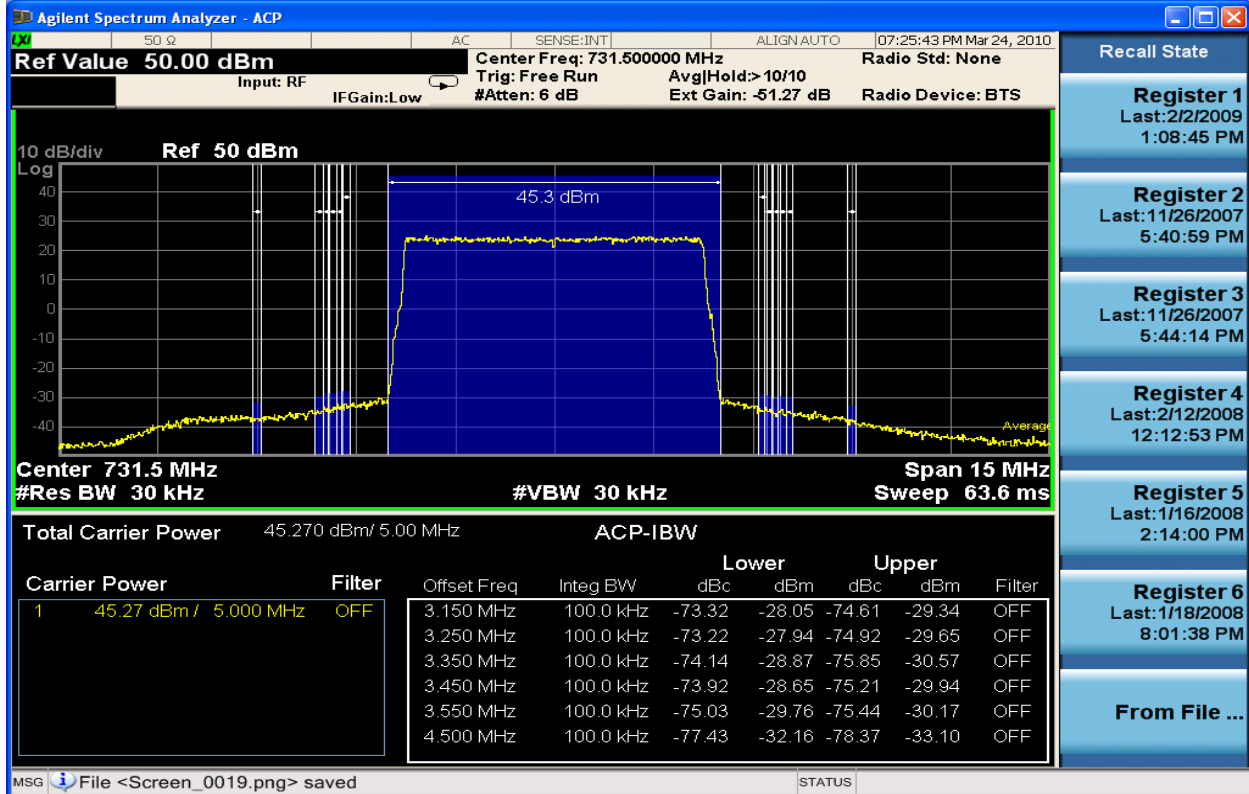

Figure 6-171 Spurious Emissions 731.5MHz TX2\_64QAM 5MHz Band Edge (ACP 650kHz - 2MHz)

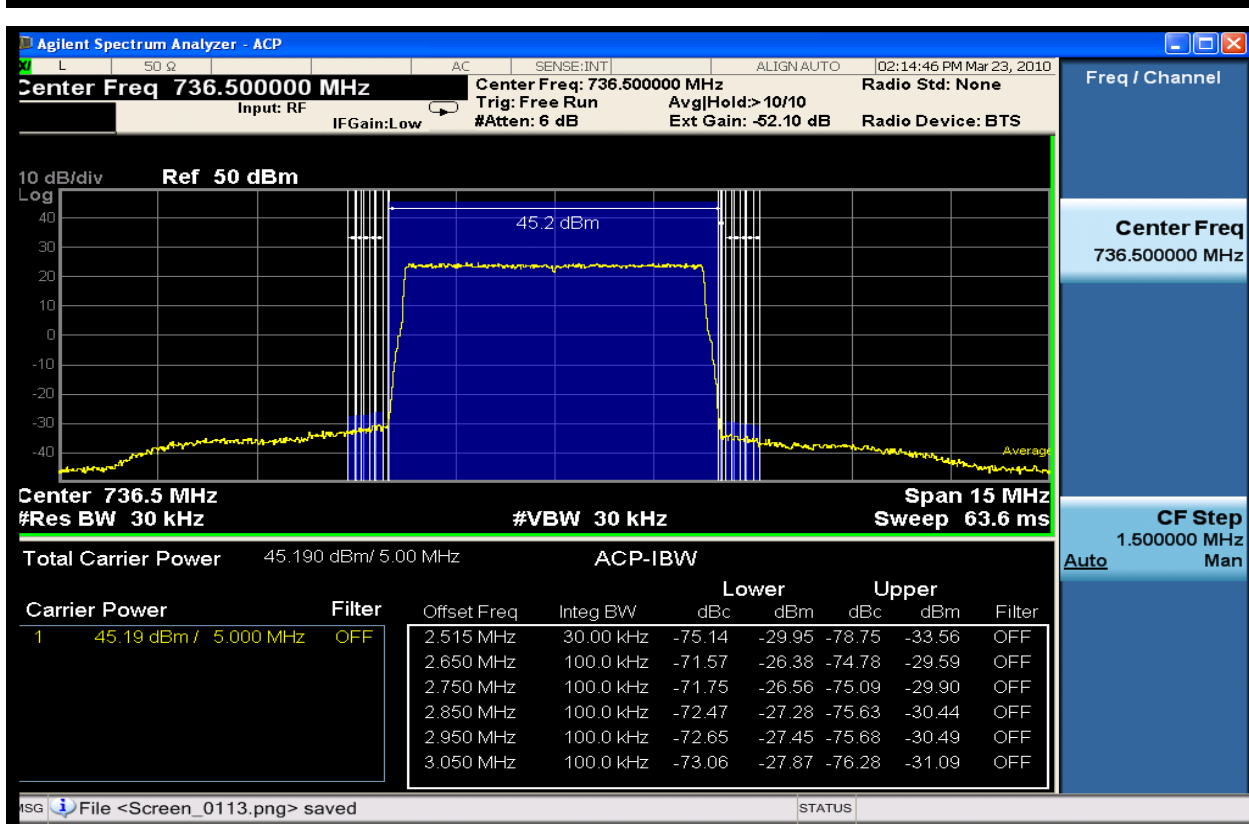

Figure 6-172 Spurious Emissions 736.5MHz TX1\_QPSK 5MHz Band Edge (ACP 15kHz – 550kHz)

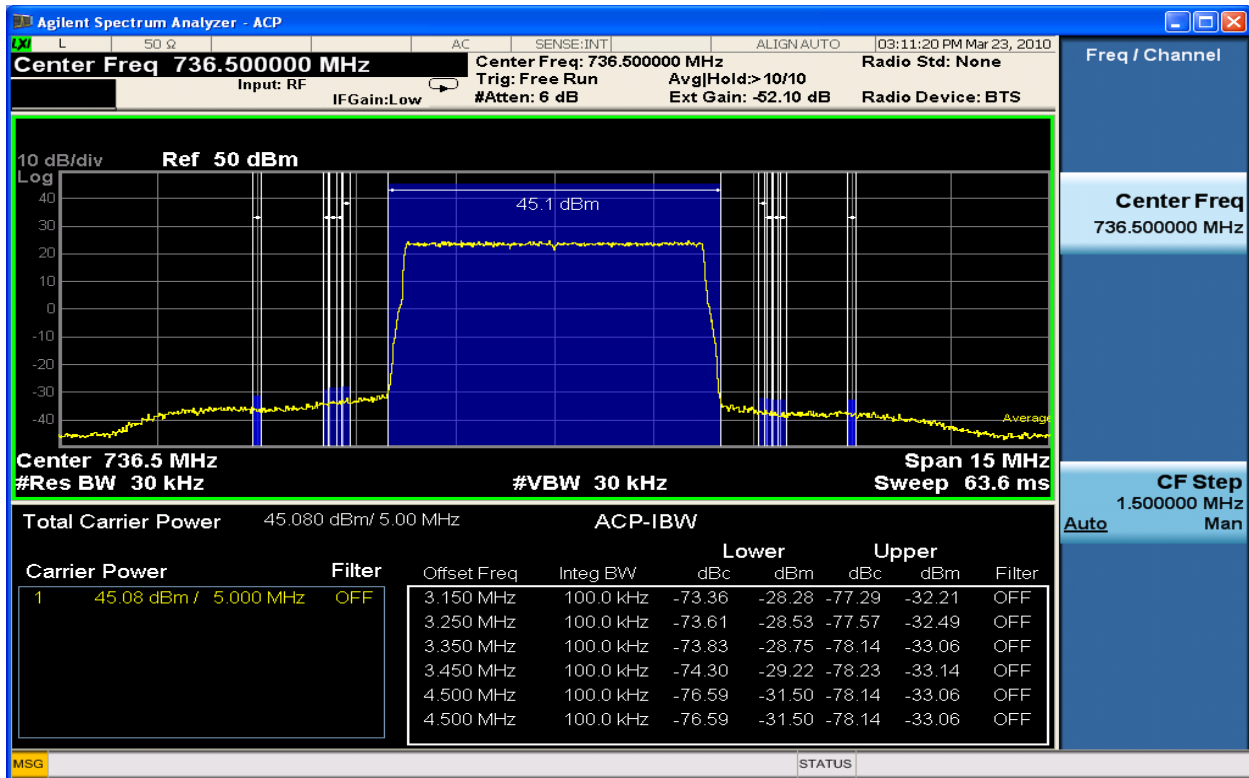

Figure 6-173 Spurious Emissions 736.5MHz TX1\_QPSK 5MHz Band Edge (ACP 650kHz – 2MHz)

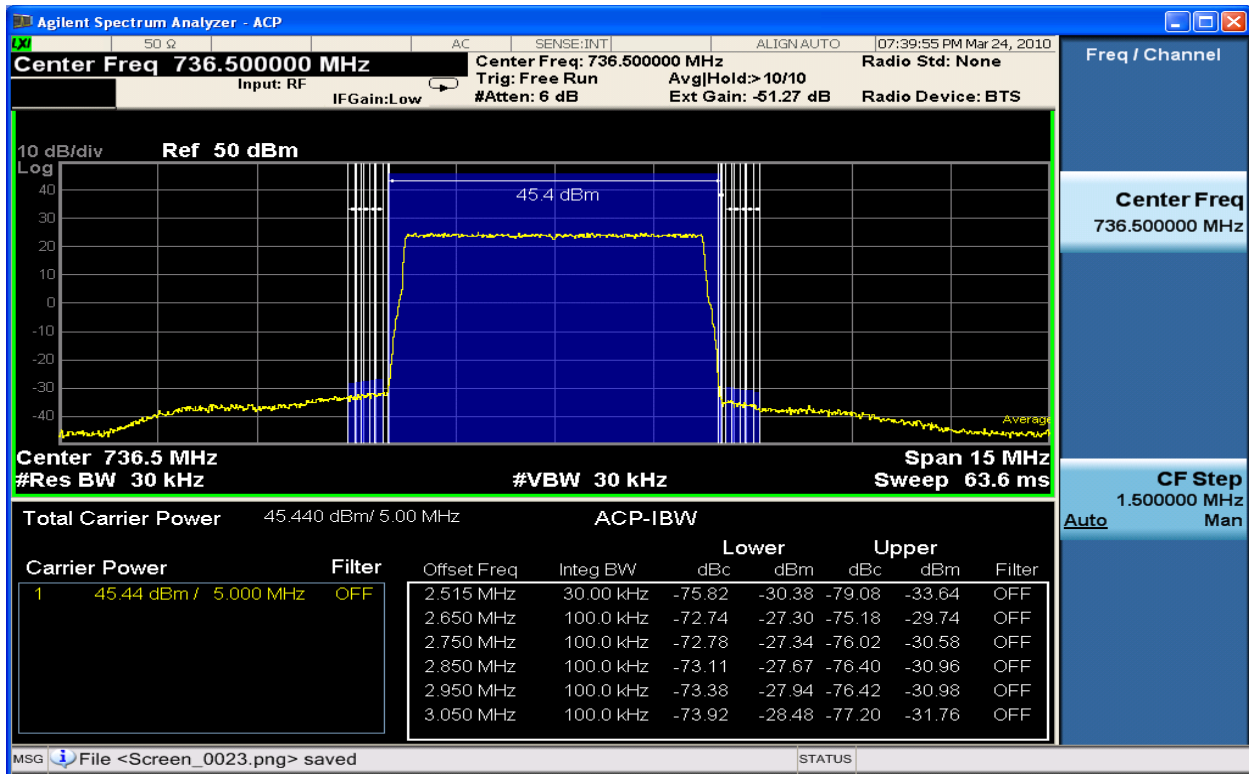

Figure 6-174 Spurious Emissions 736.5MHz TX2\_QPSK 5MHz Band Edge (ACP 15kHz – 550kHz)

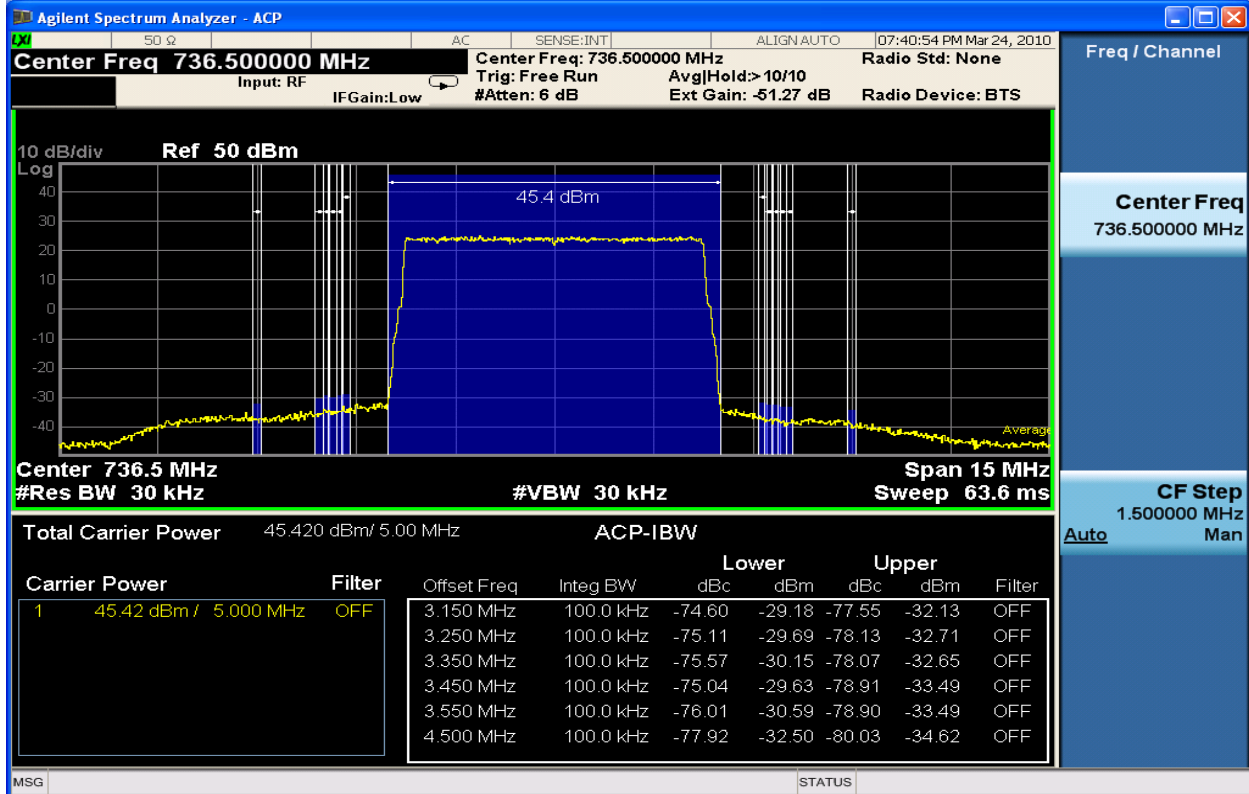

Figure 6-175 Spurious Emissions 736.5MHz TX2\_QPSK 5MHz Band Edge (ACP 650kHz – 2MHz)



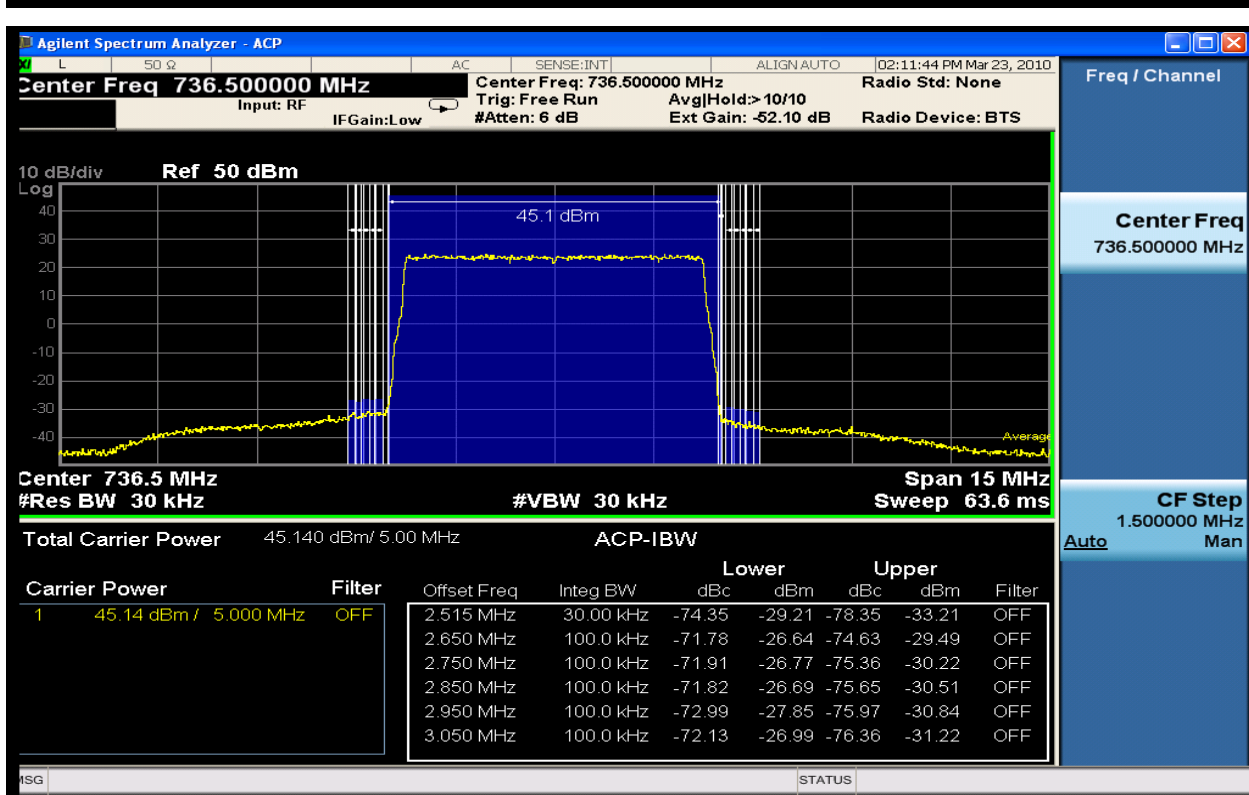

Figure 6-176 Spurious Emissions 736.5MHz TX1\_16QAM 5MHz Band Edge (ACP 15kHz – 550kHz)

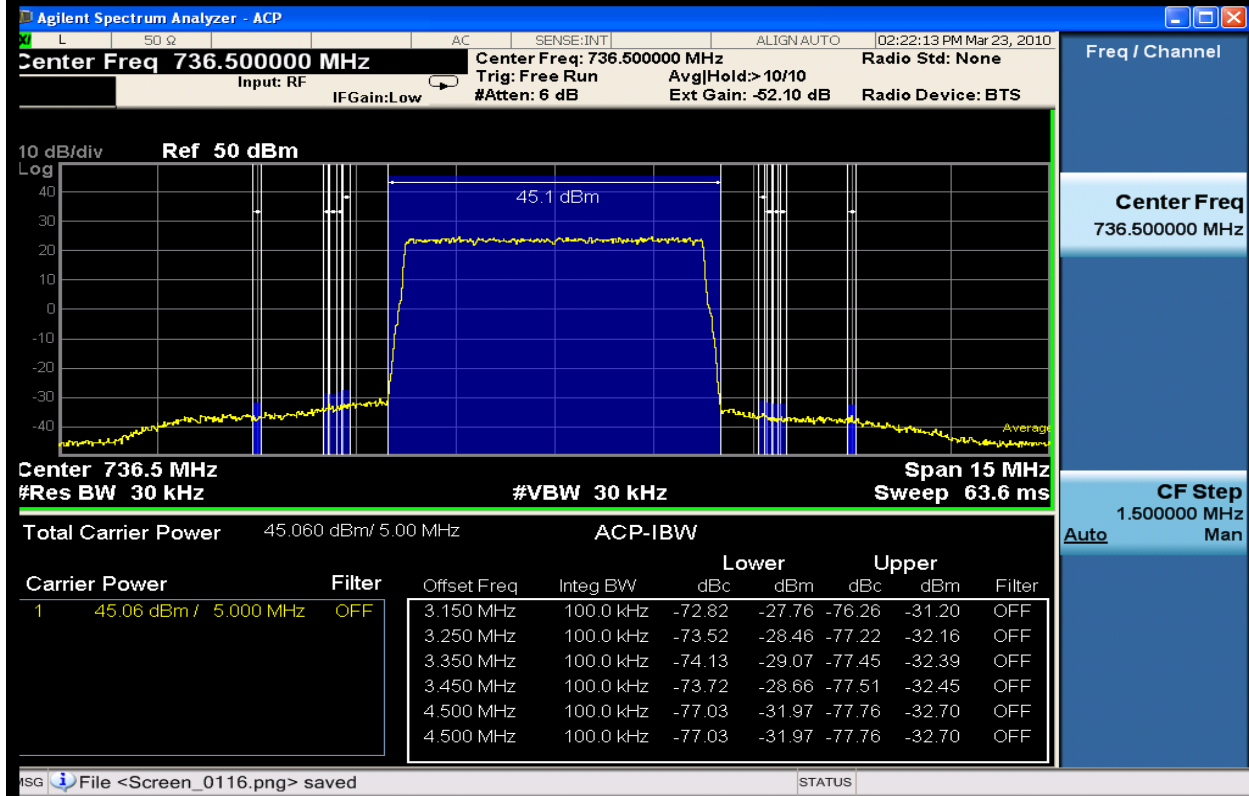

Figure 6-177 Spurious Emissions 736.5MHz TX1\_16QAM 5MHz Band Edge (ACP 650kHz – 2MHz)

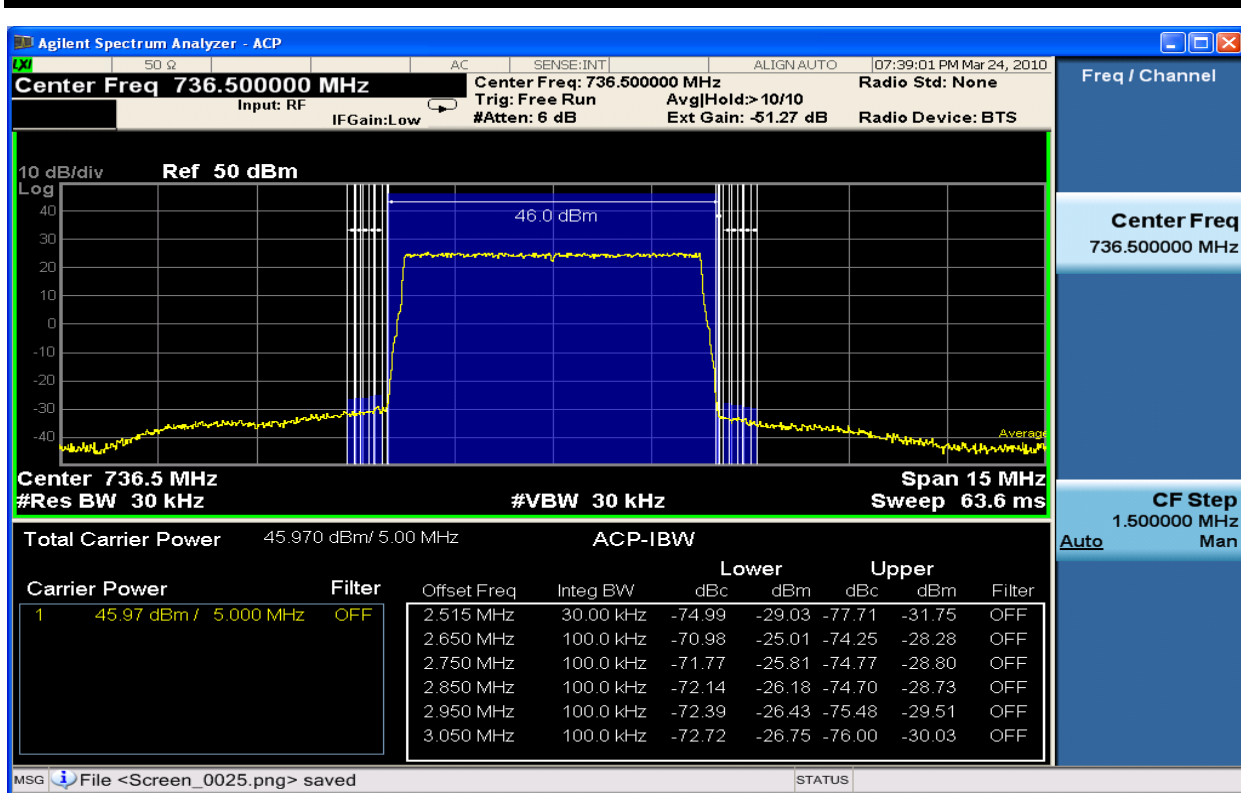

Figure 6-178 Spurious Emissions 736.5MHz TX2\_16QAM 5MHz Band Edge (ACP 15kHz – 550kHz)

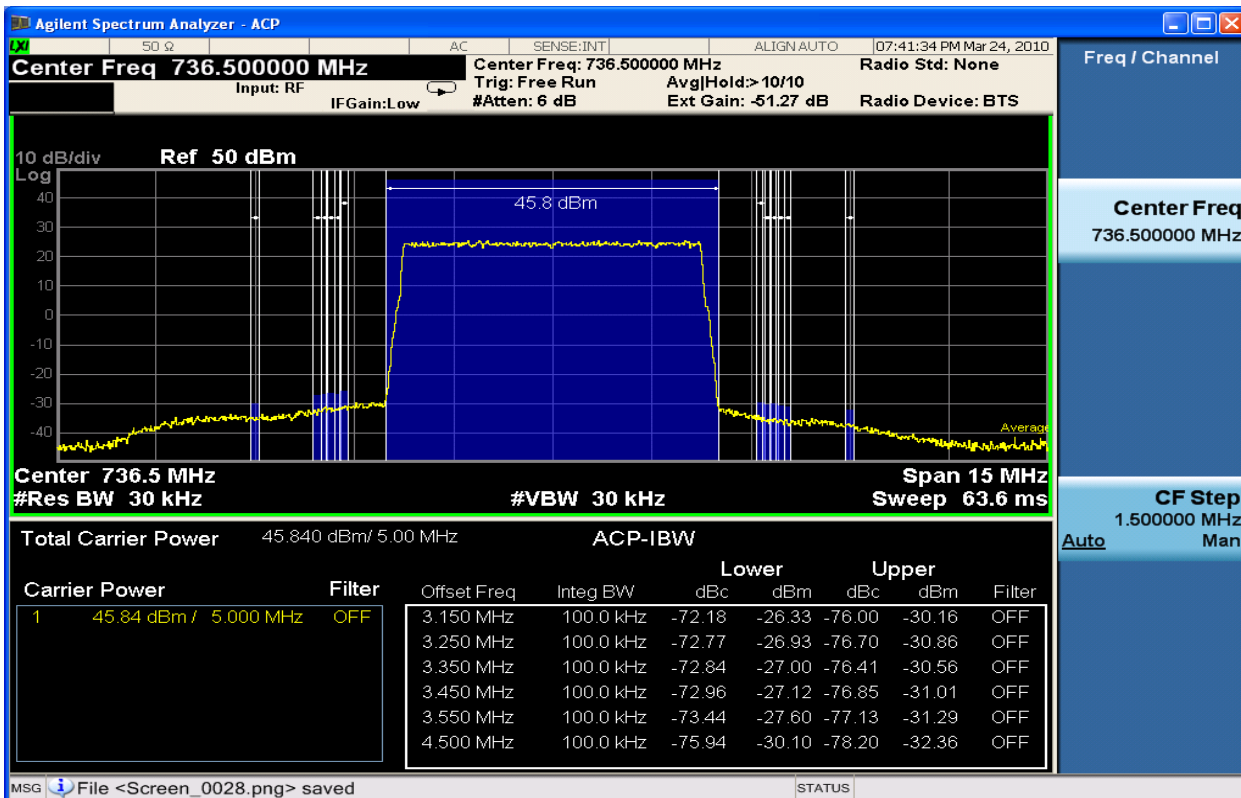

Figure 6-179 Spurious Emissions 736.5MHz TX2\_16QAM 5MHz Band Edge (ACP 650kHz – 2MHz)

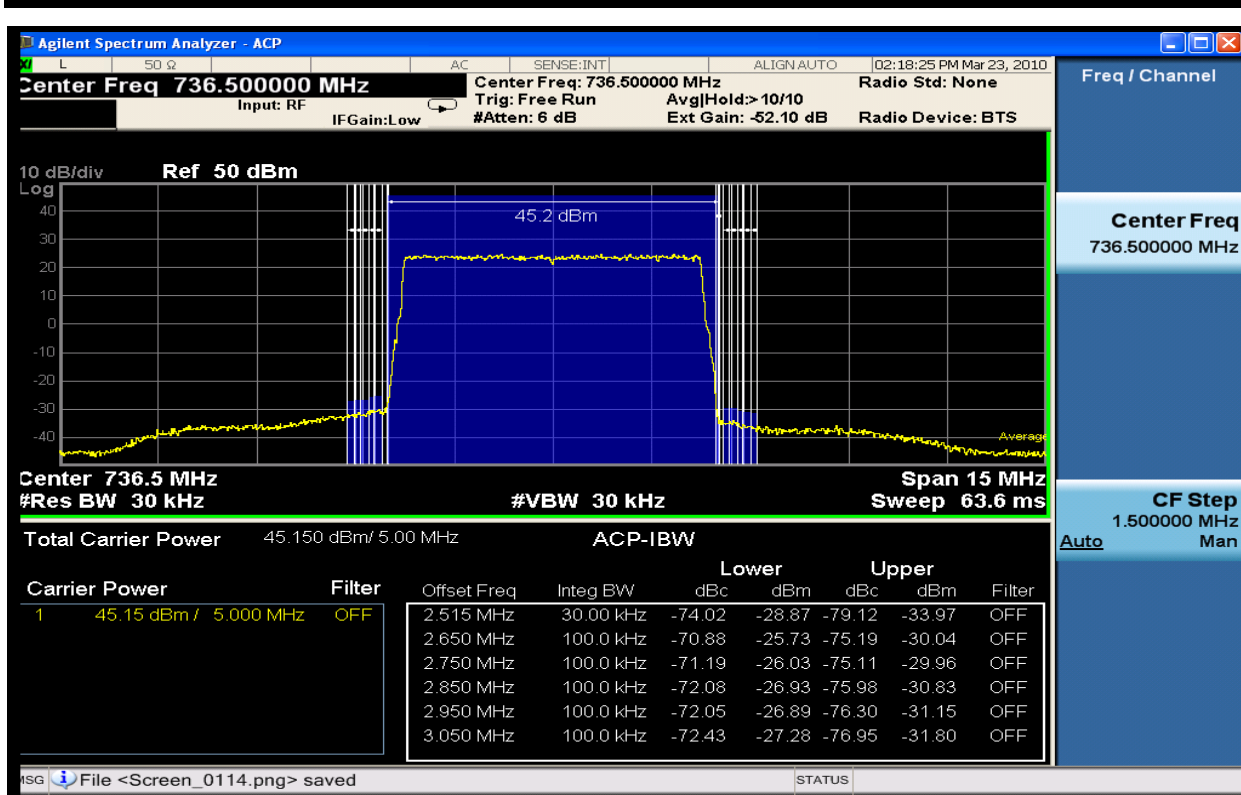

Figure 6-180 Spurious Emissions 736.5MHz TX1\_64QAM 5MHz Band Edge (ACP 15kHz – 550kHz)

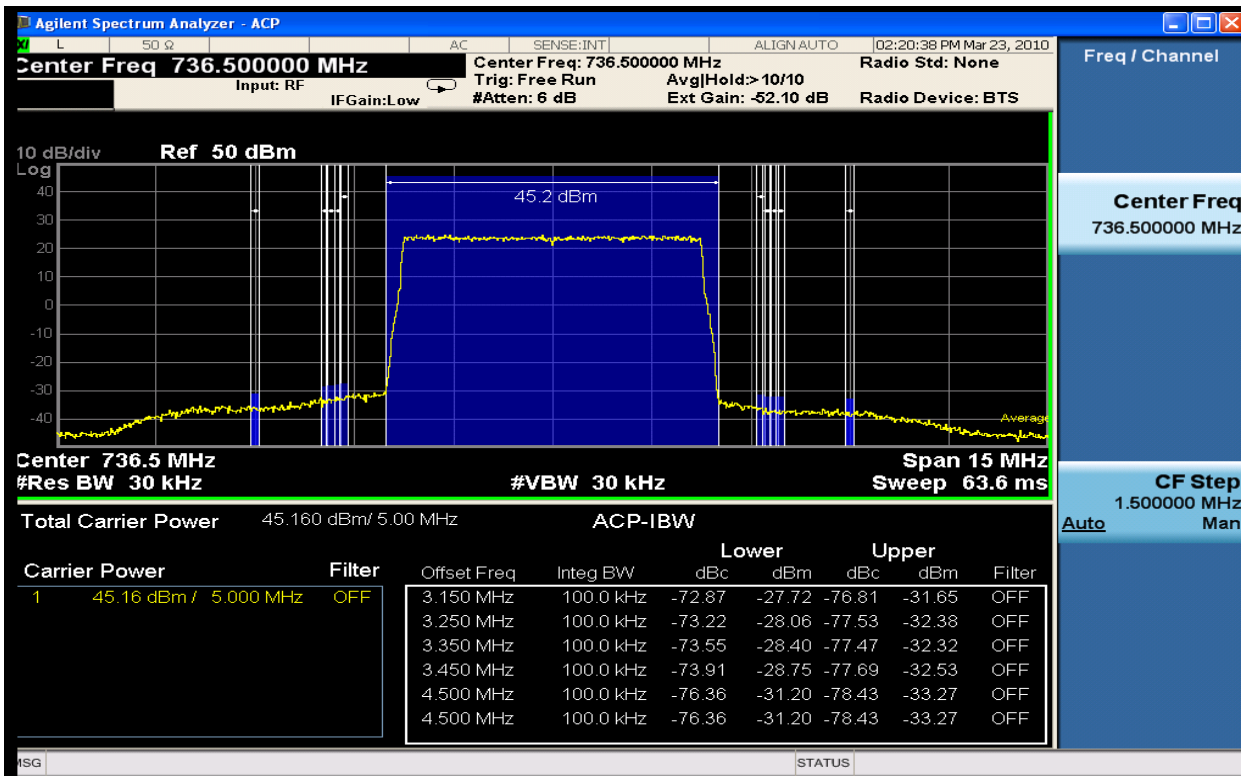

Figure 6-181 Spurious Emissions 736.5MHz TX1\_64QAM 5MHz Band Edge (ACP 650kHz – 2MHz)

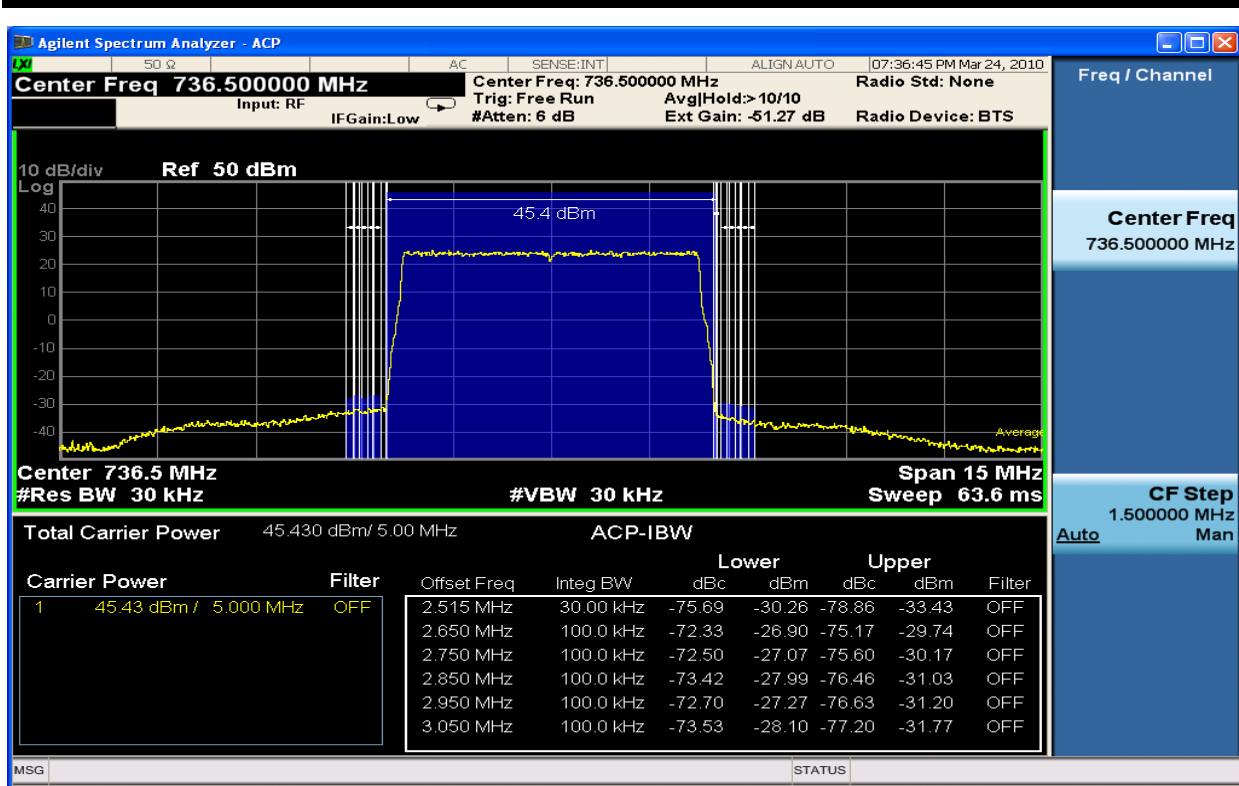

Figure 6-182 Spurious Emissions 736.5MHz TX2\_64QAM 5MHz Band Edge (ACP 15kHz – 550kHz)

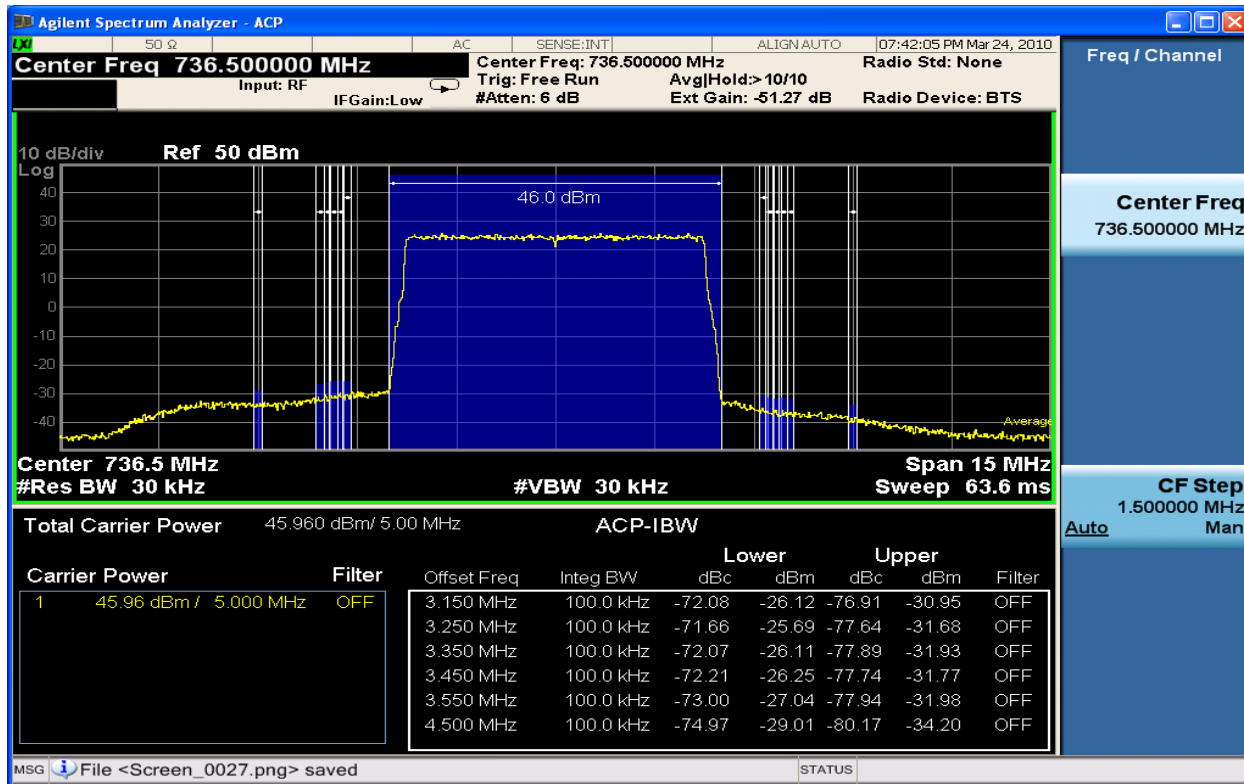

Figure 6-183 Spurious Emissions 736.5MHz TX2\_64QAM 5MHz Band Edge (ACP 650kHz – 2MHz)

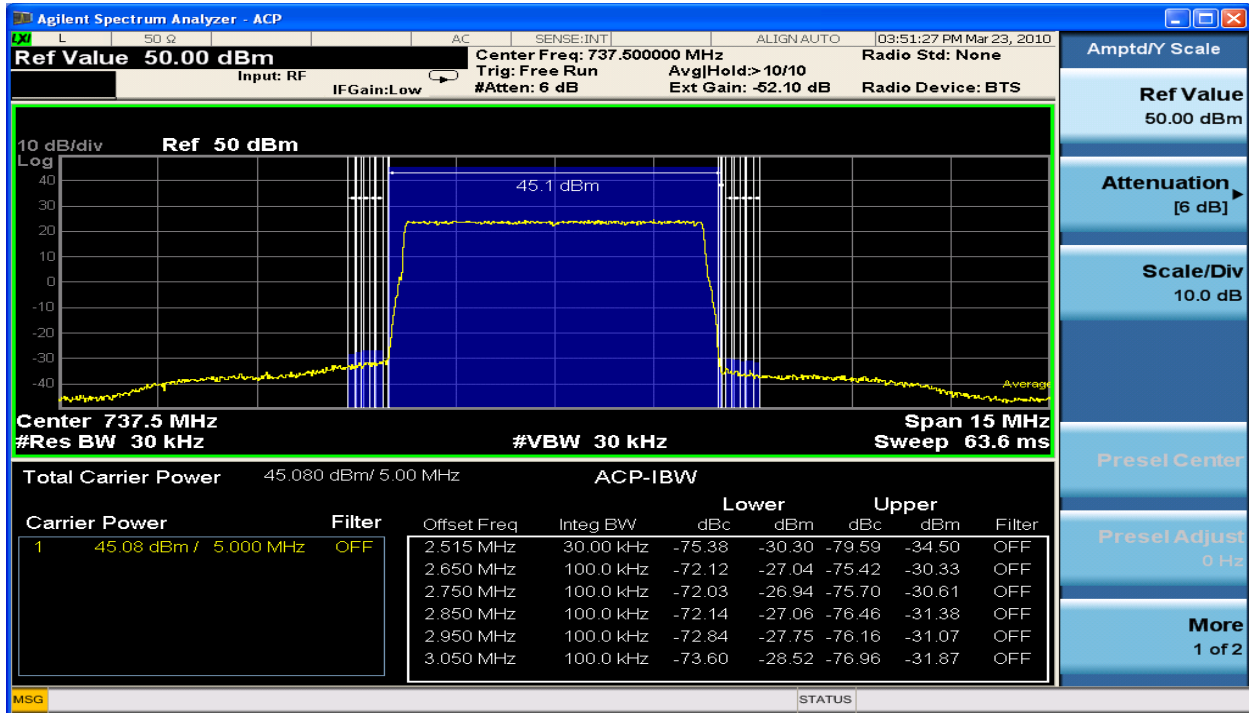

Figure 6-184 Spurious Emissions 737.5MHz TX1\_QPSK 5MHz Band Edge (ACP 15kHz – 550KHz)

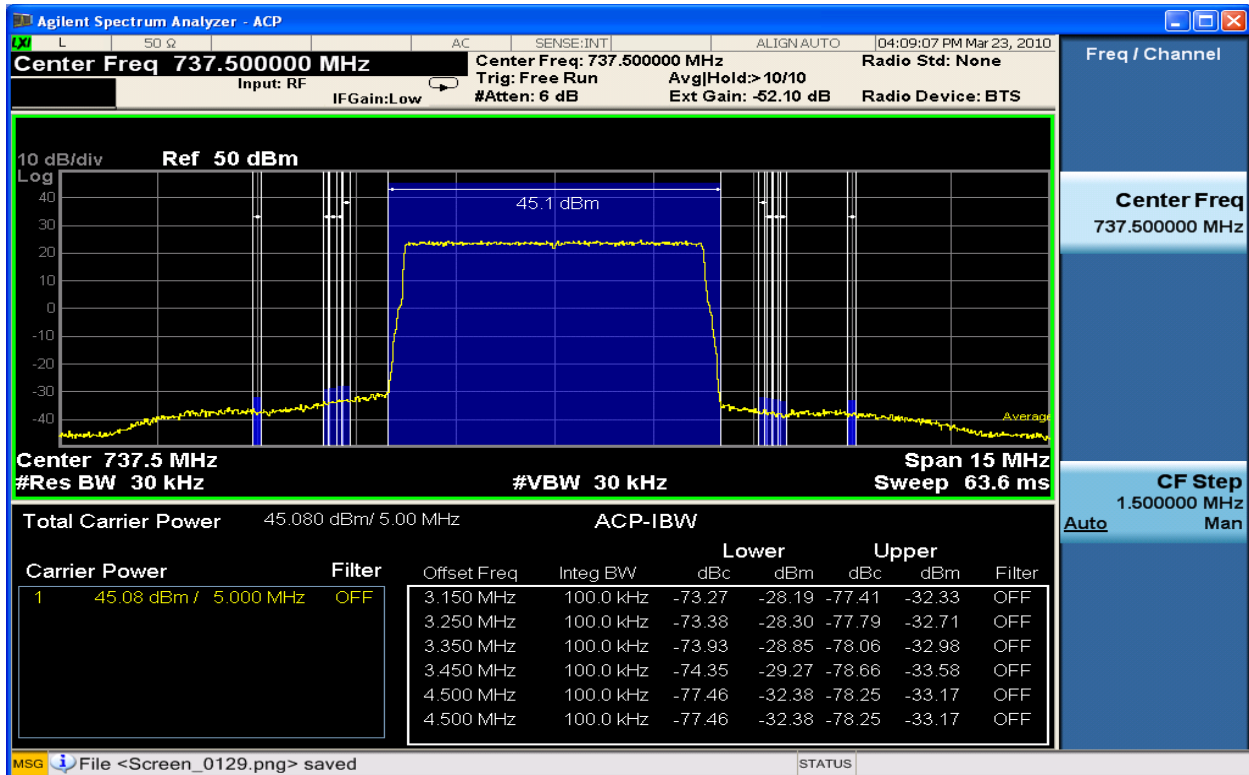

Figure 6-185 Spurious Emissions 737.5MHz TX1\_QPSK 5MHz Band Edge (ACP 650kHz – 2MHz)

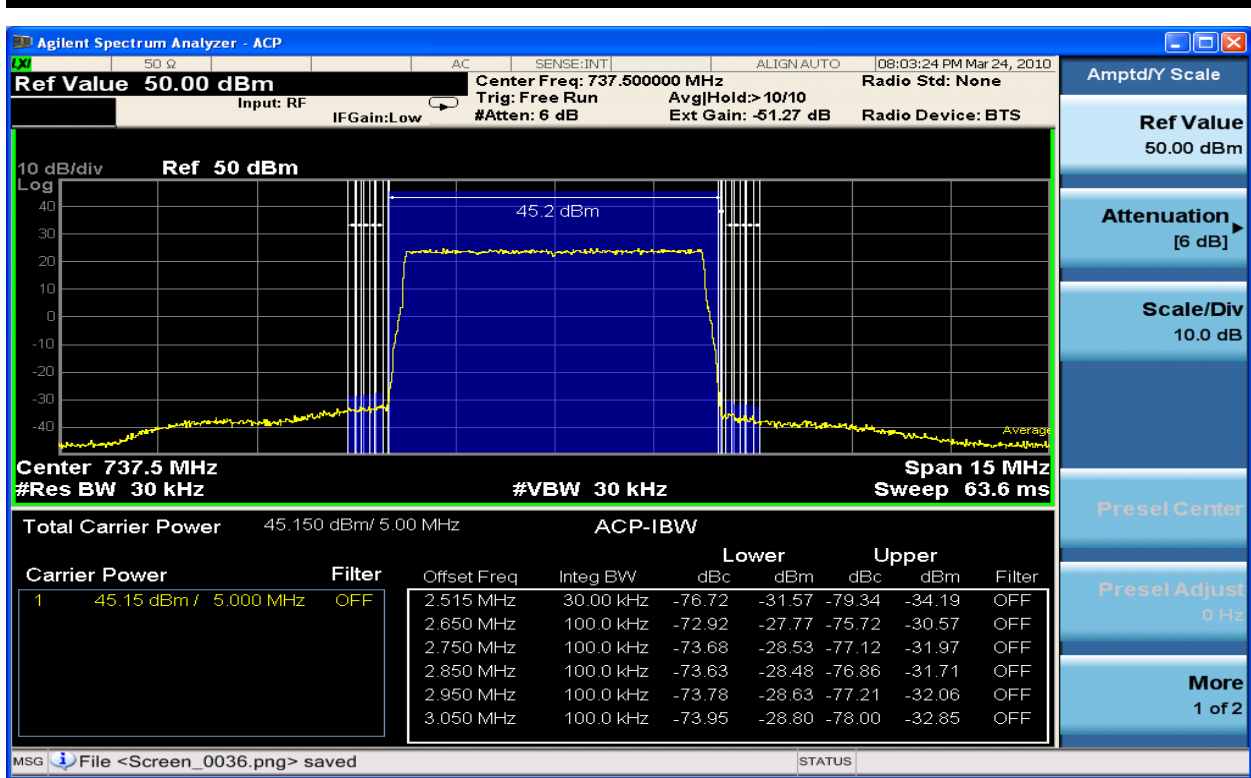

Figure 6-186 Spurious Emissions 737.5MHz TX2\_QPSK 5MHz Band Edge (ACP 15kHz – 550kHz)

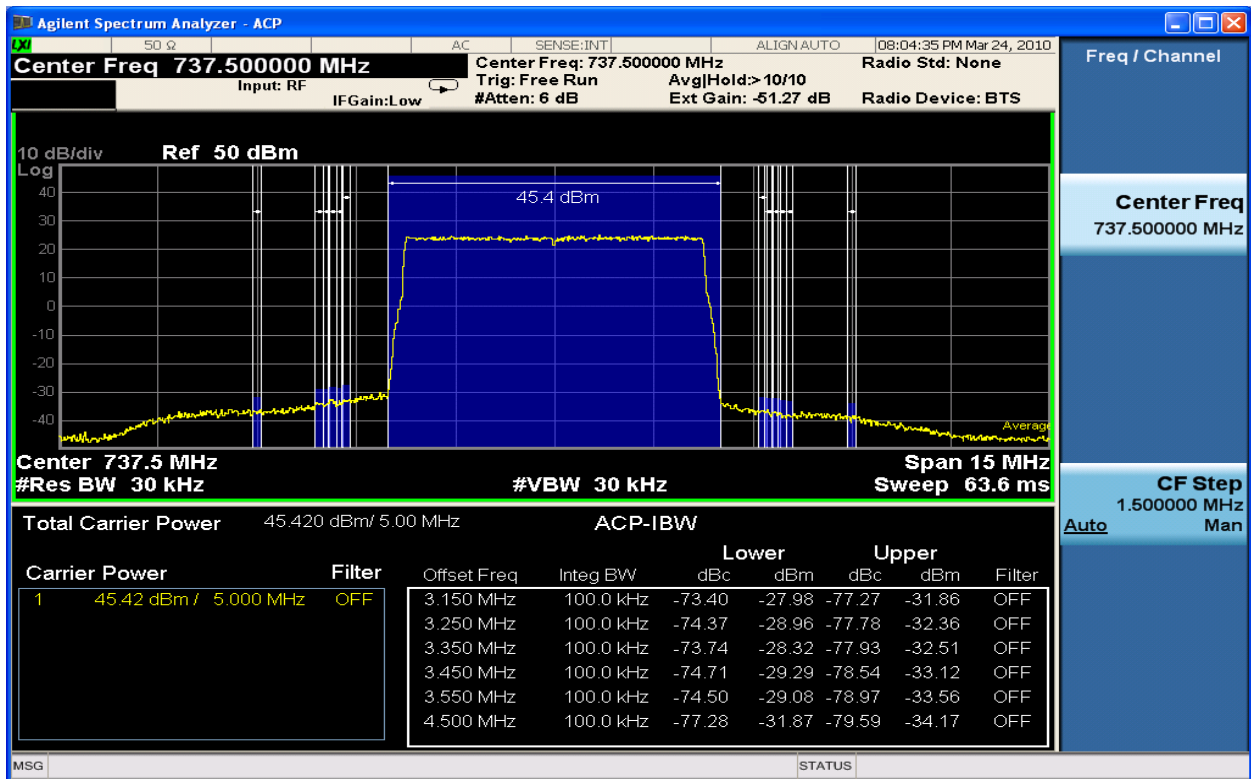

Figure 6-187 Spurious Emissions 737.5MHz TX2\_QPSK 5MHz Band Edge (ACP 650kHz – 2MHz)

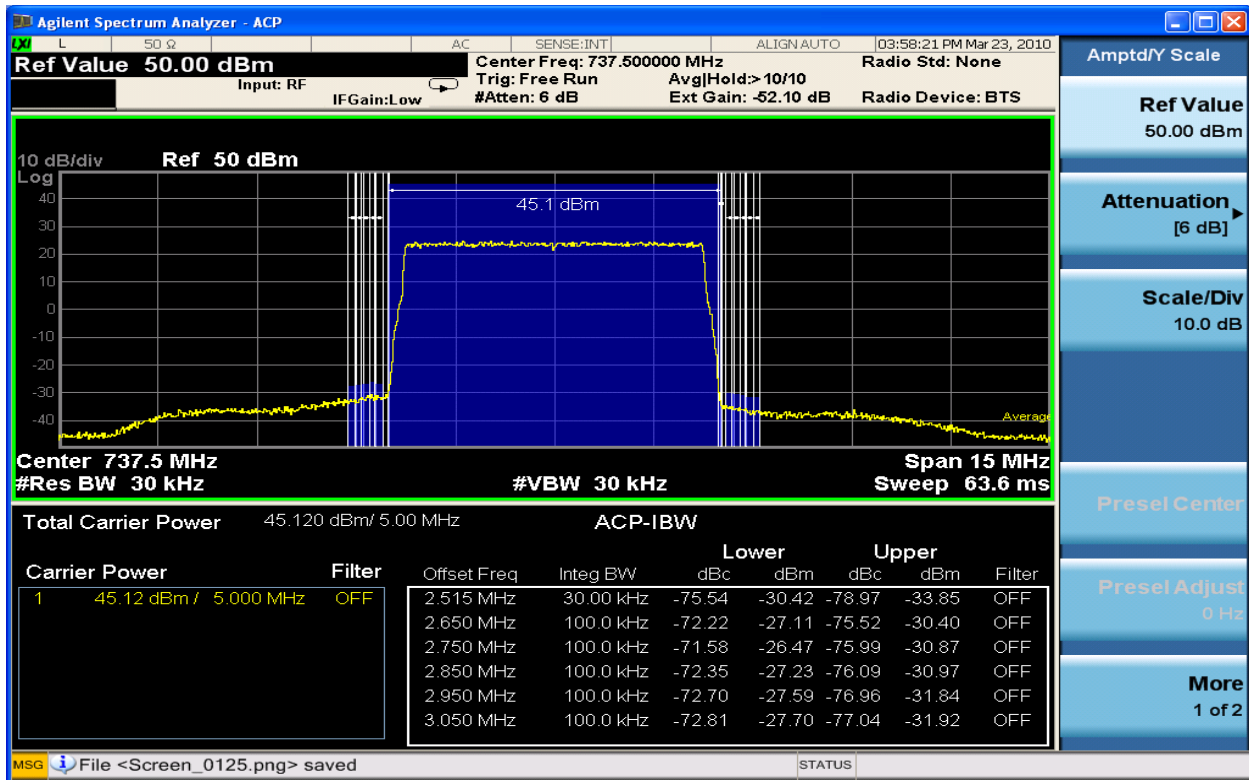

Figure 6-188 Spurious Emissions 737.5MHz TX1\_16QAM 5MHz Band Edge (ACP 15kHz – 550KHz)

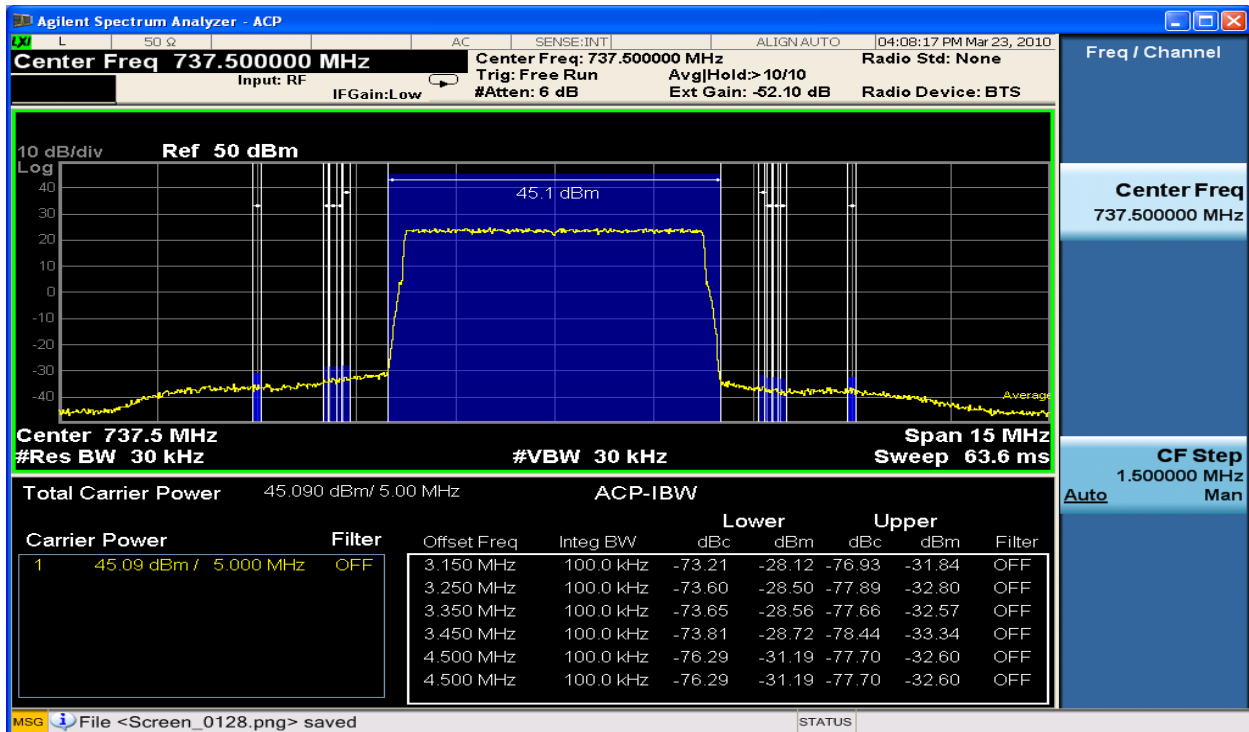

Figure 6-189 Spurious Emissions 737.5MHz TX1\_16QAM 5MHz Band Edge (ACP 650KHz – 2MHz)

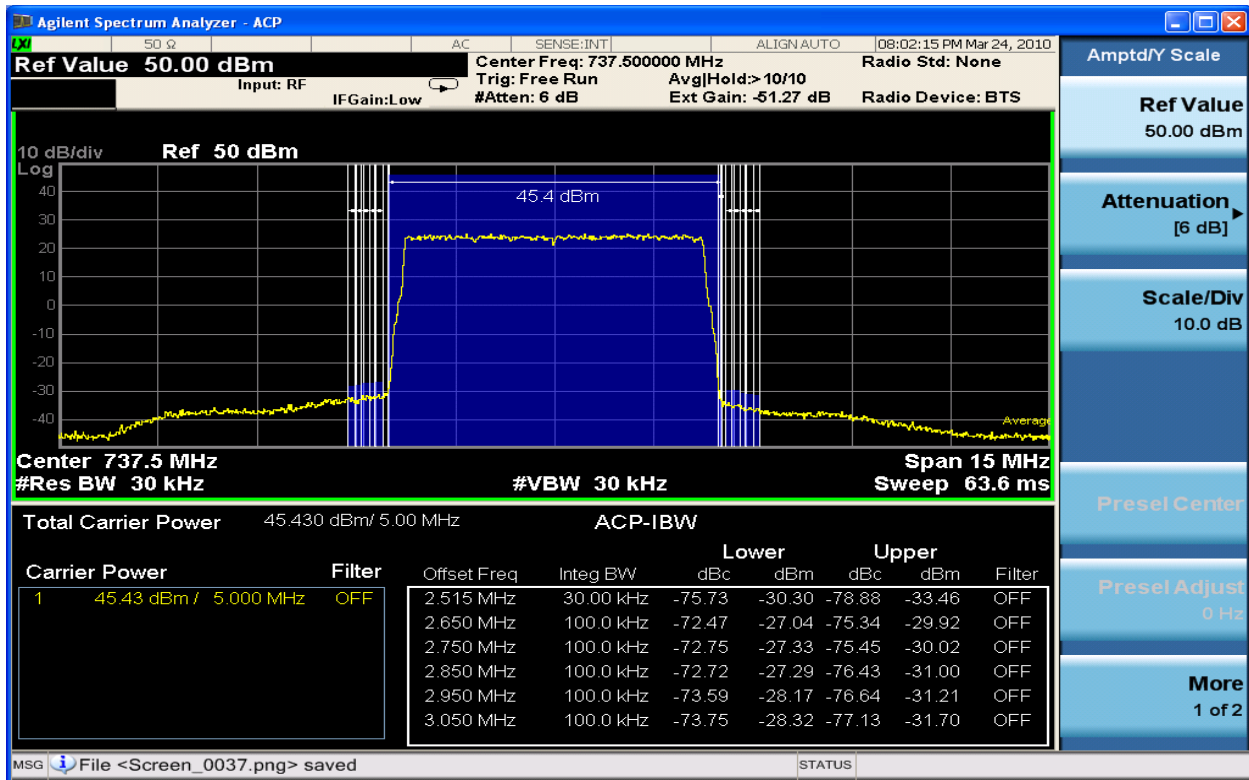

Figure 6-190 Spurious Emissions 737.5MHz TX2\_16QAM 5MHz Band Edge (ACP 15kHz – 550KHz)

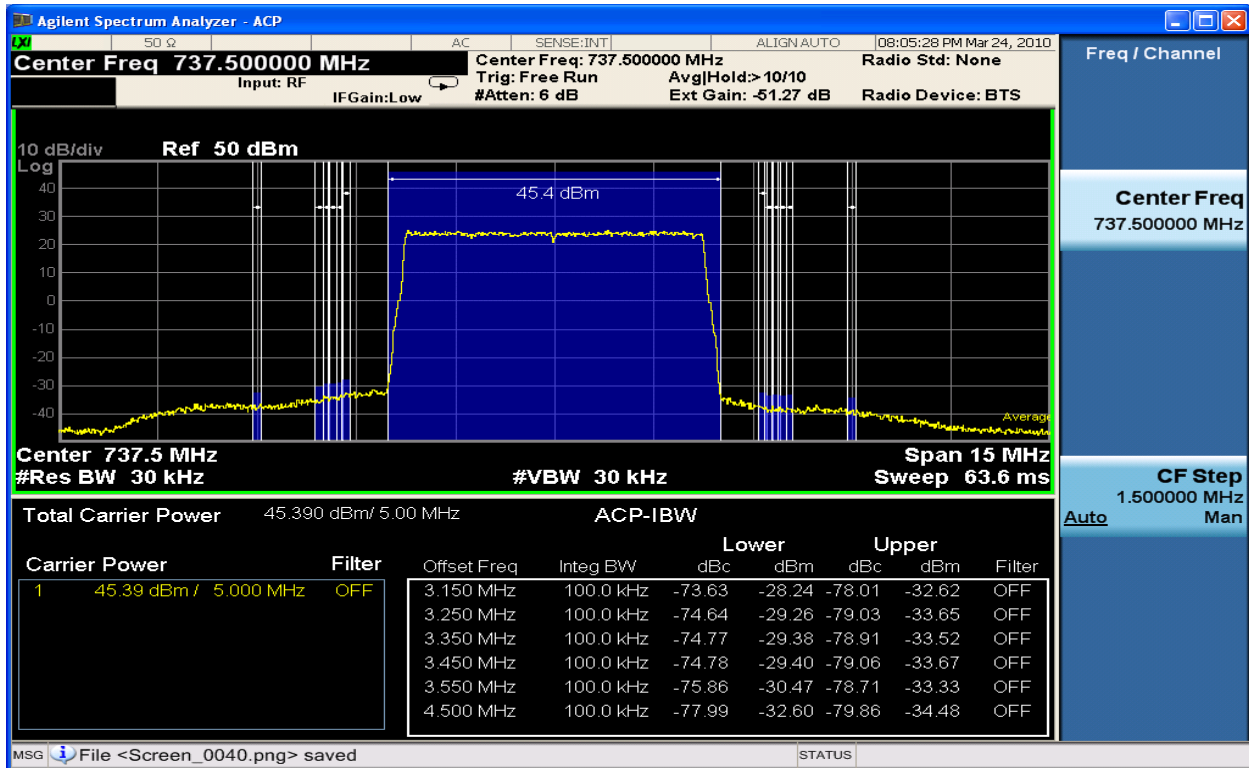

Figure 6-191 Spurious Emissions 737.5MHz TX2\_16QAM 5MHz Band Edge (ACP 650kHz – 2MHz)



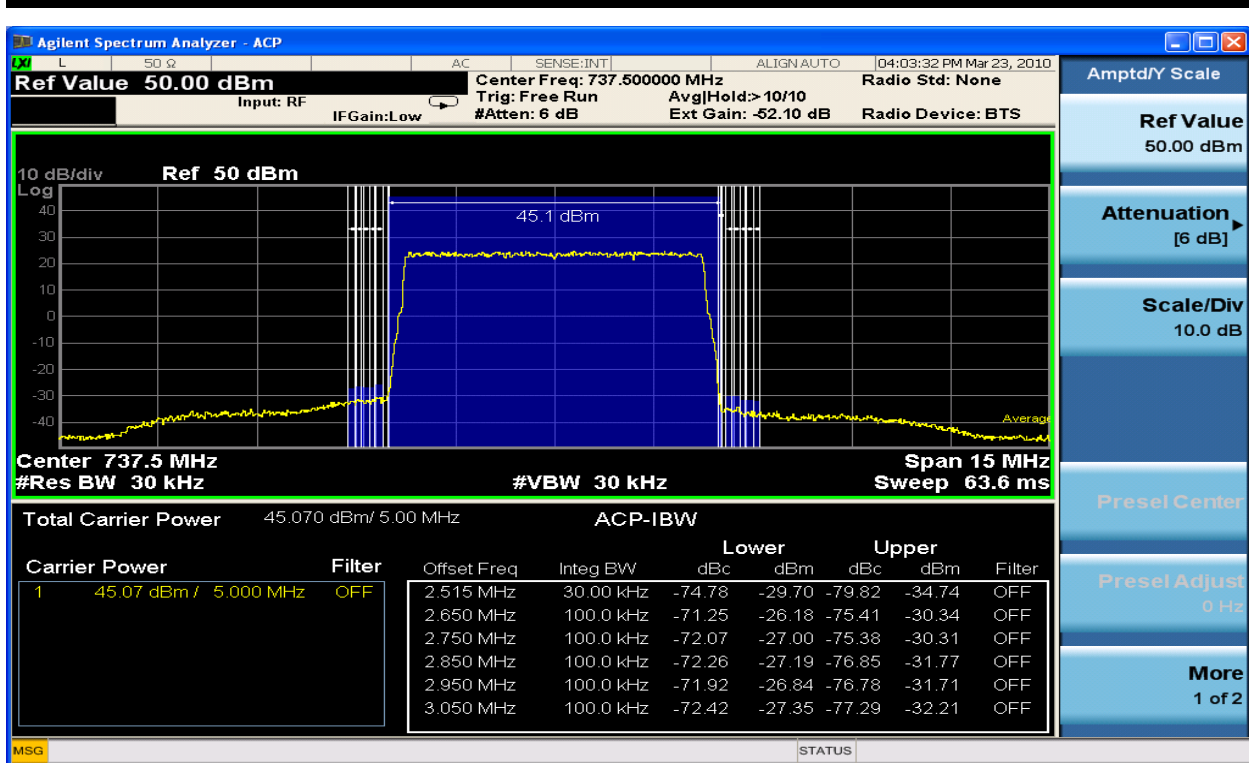

Figure 6-192 Spurious Emissions 737.5MHz TX1\_64QAM 5MHz Band Edge (ACP 15kHz – 550KHz)

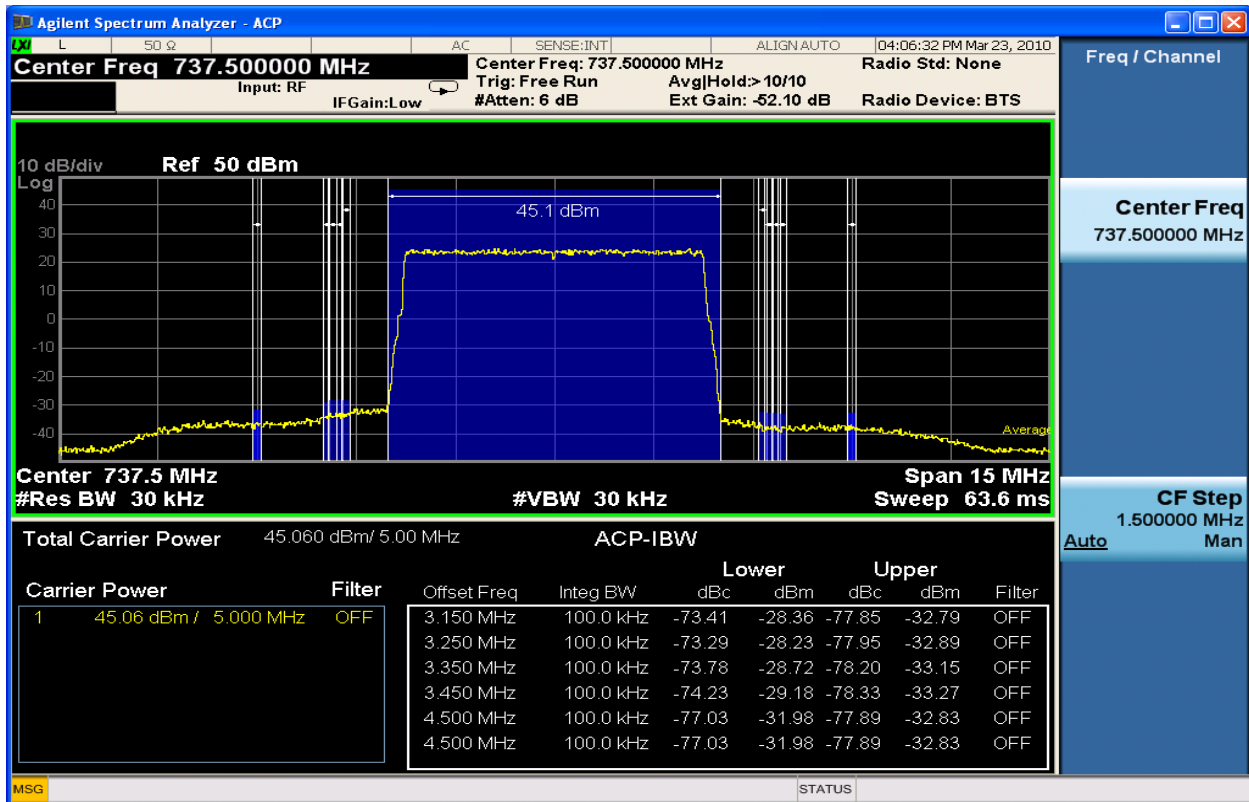

Figure 6-193 Spurious Emissions 737.5MHz TX1\_64QAM 5MHz Band Edge (ACP 650kHz – 2MHz)

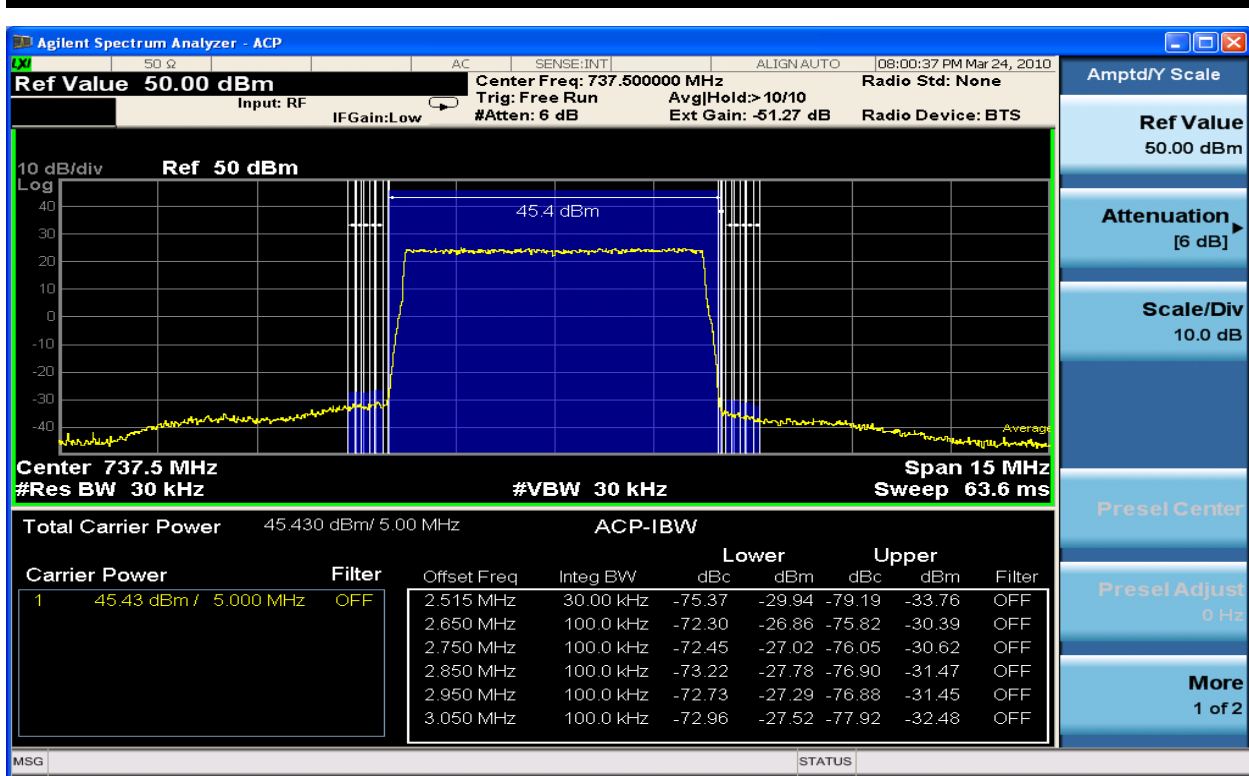

Figure 6-194 Spurious Emissions 737.5MHz TX2\_64QAM 5MHz Band Edge (ACP 15kHz – 550KHz)

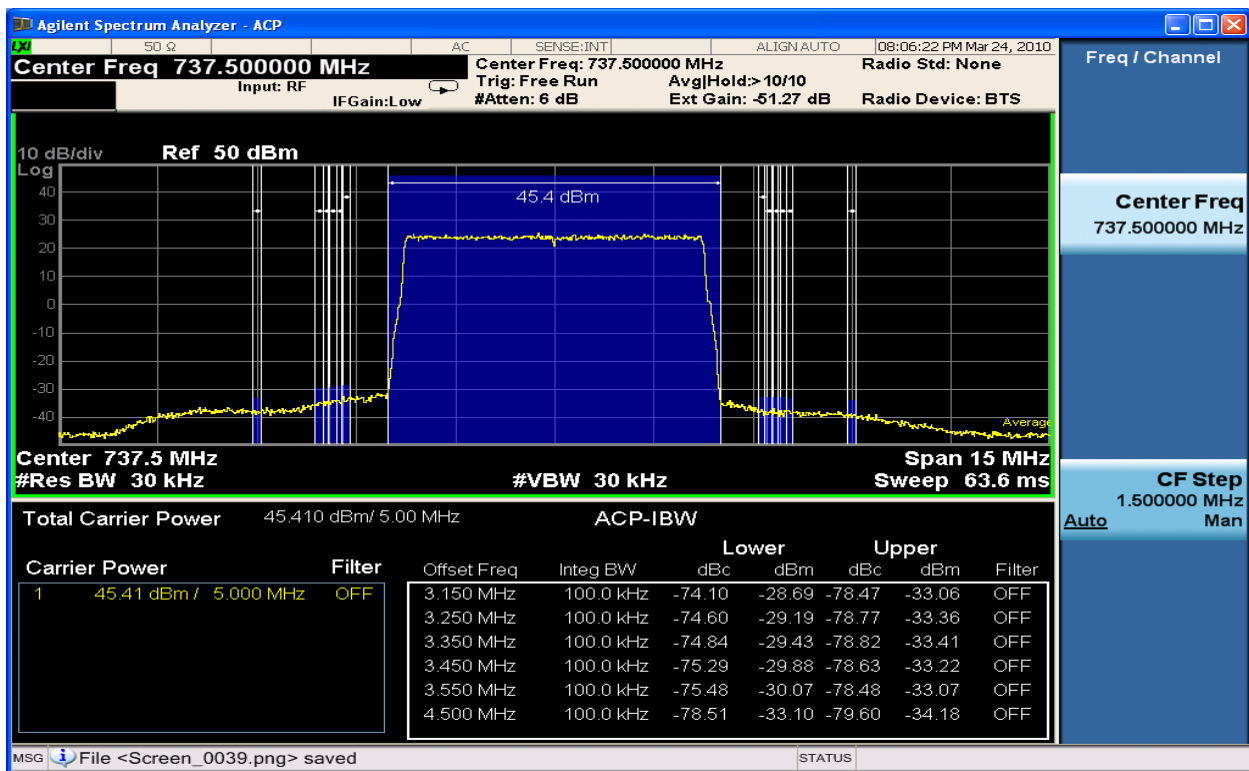

Figure 6-195 Spurious Emissions 737.5MHz TX2\_64QAM 5MHz Band Edge (ACP 650kHz – 2MHz)

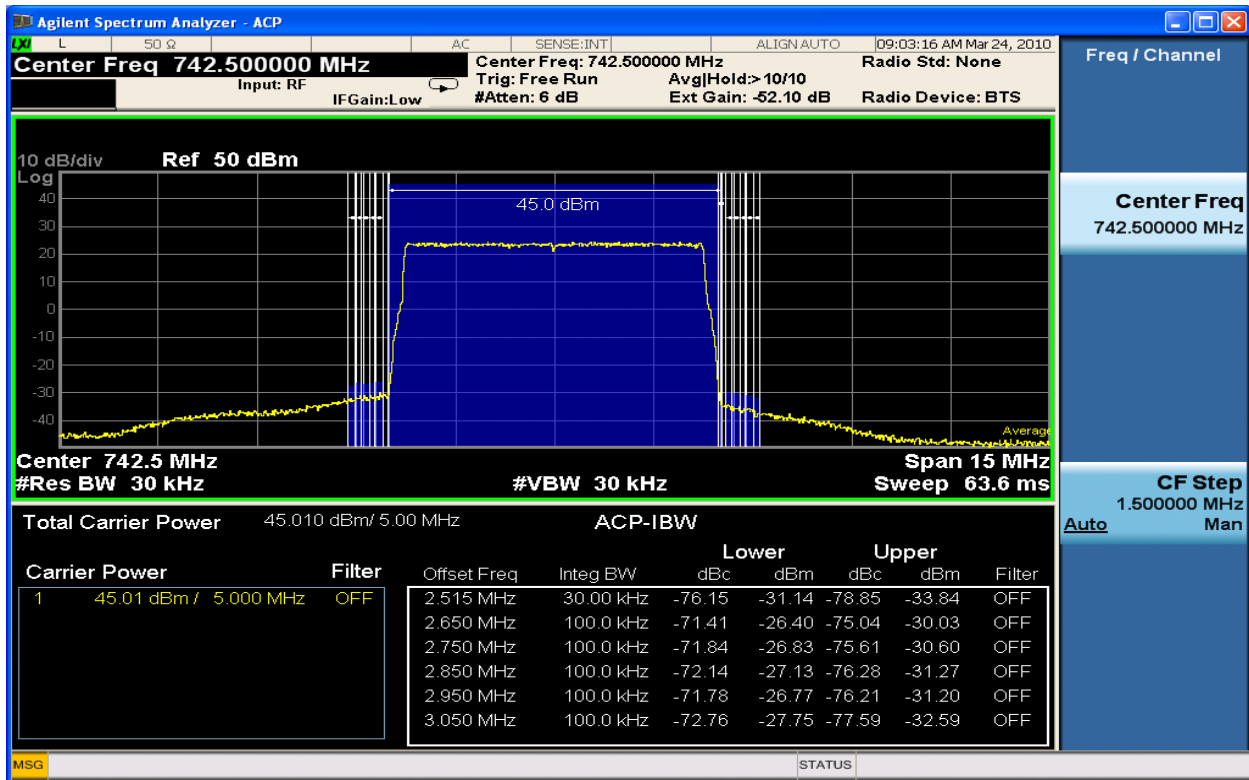

Figure 6-196 Spurious Emissions 742.5MHz TX1\_QPSK 5MHz Band Edge (ACP 15kHz – 550KHz)

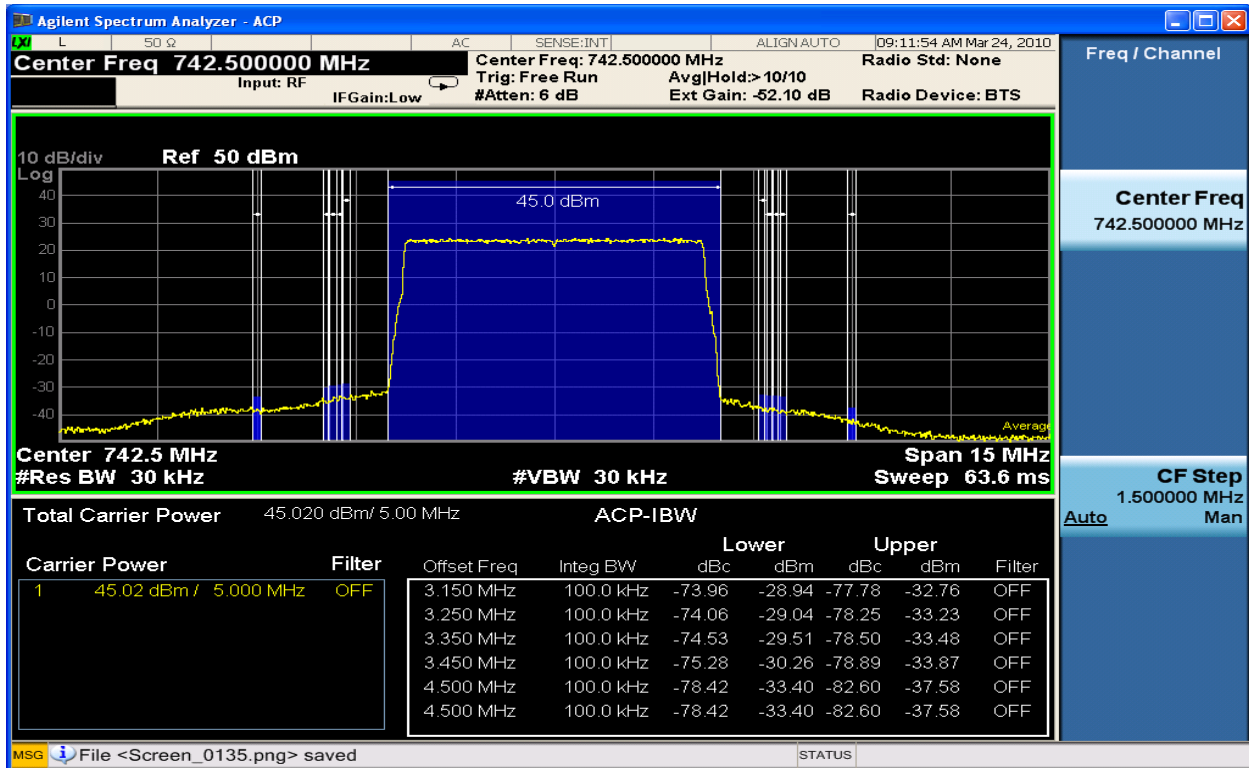

Figure 6-197 Spurious Emissions 742.5MHz TX1\_QPSK 5MHz Band Edge (ACP 650kHz – 2MHz)

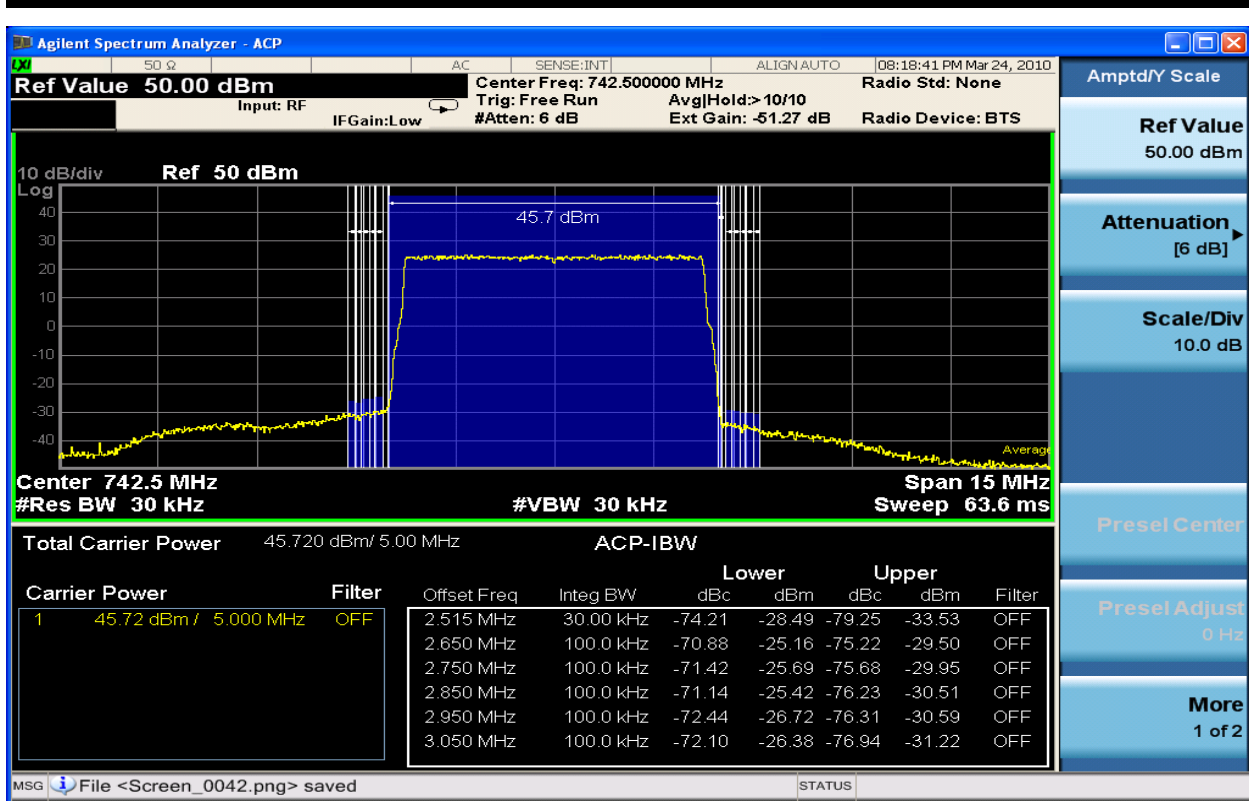

Figure 6-198 Spurious Emissions 742.5MHz TX2\_QPSK 5MHz Band Edge (ACP 15kHz – 550KHz)

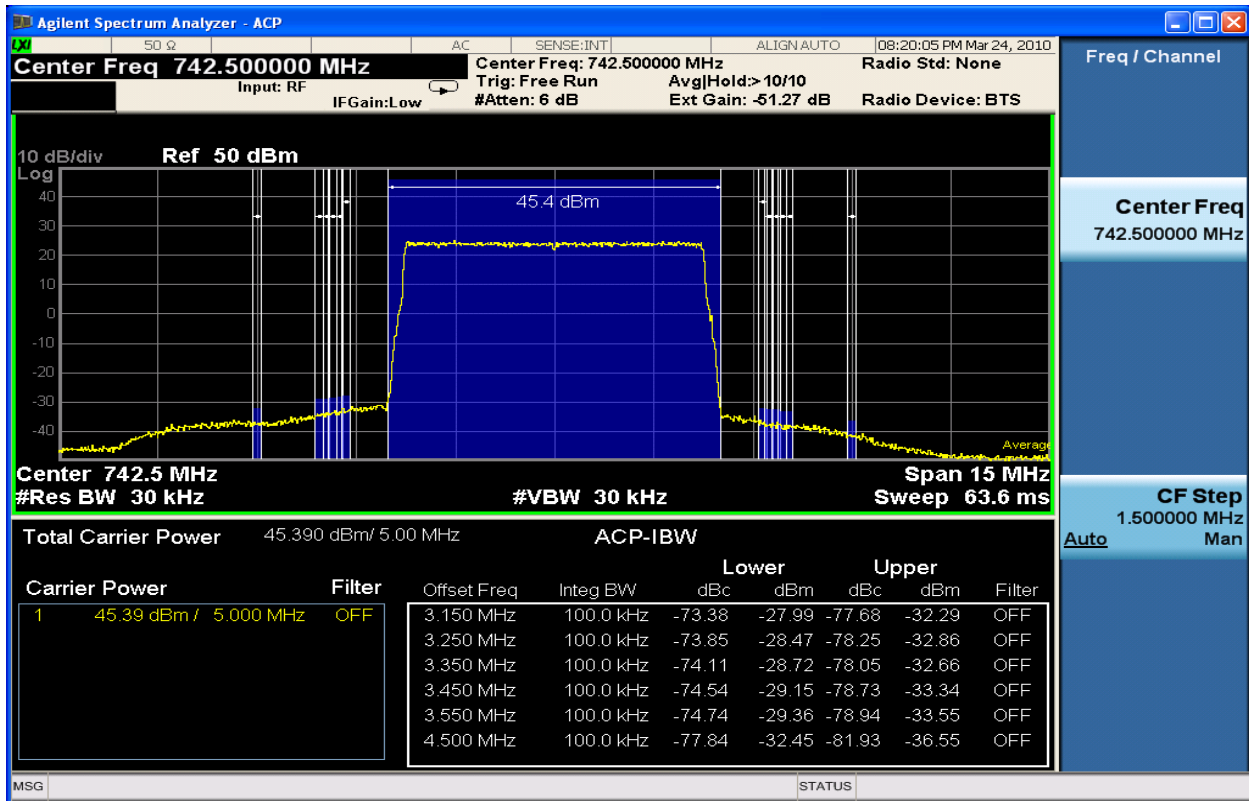

Figure 6-199 Spurious Emissions 742.5MHz TX2\_QPSK 5MHz Band Edge (ACP 650kHz – 2MHz)

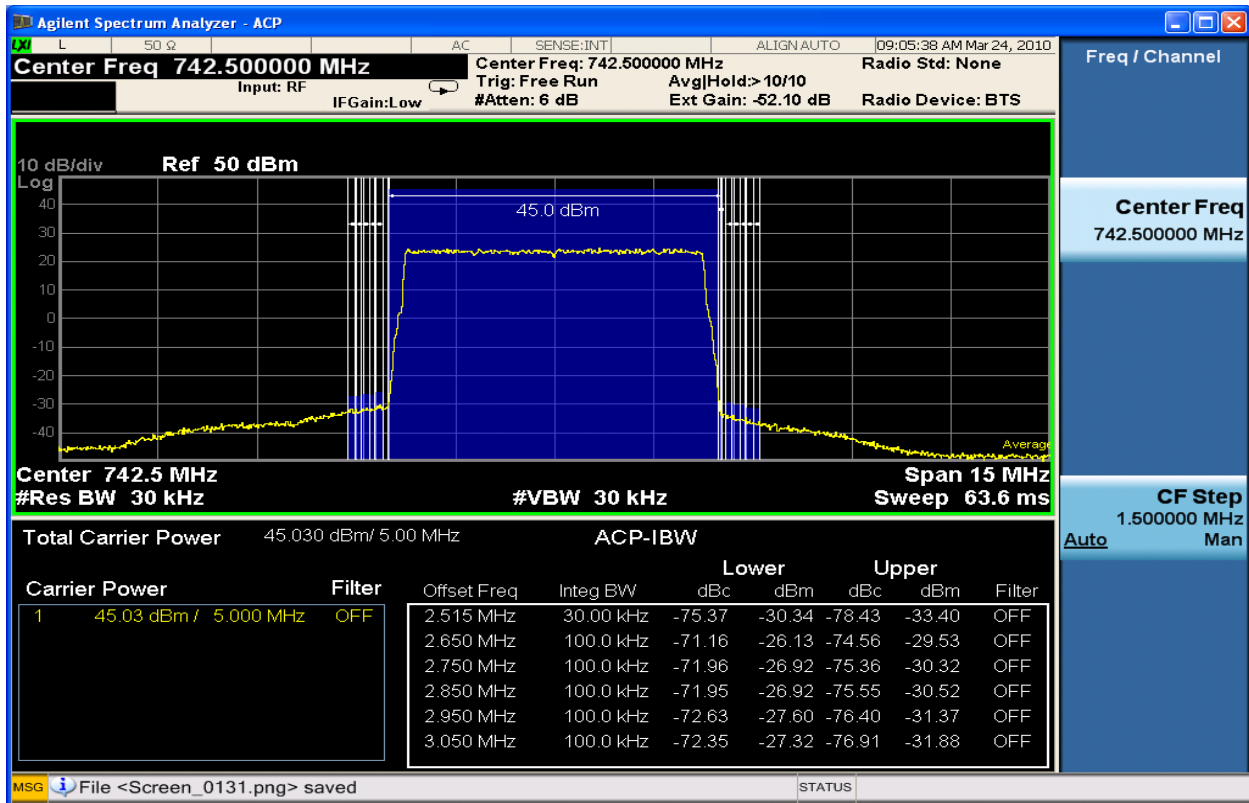

Figure 6-200 Spurious Emissions 742.5MHz TX1\_16QAM 5MHz Band Edge (ACP 15kHz – 550KHz)

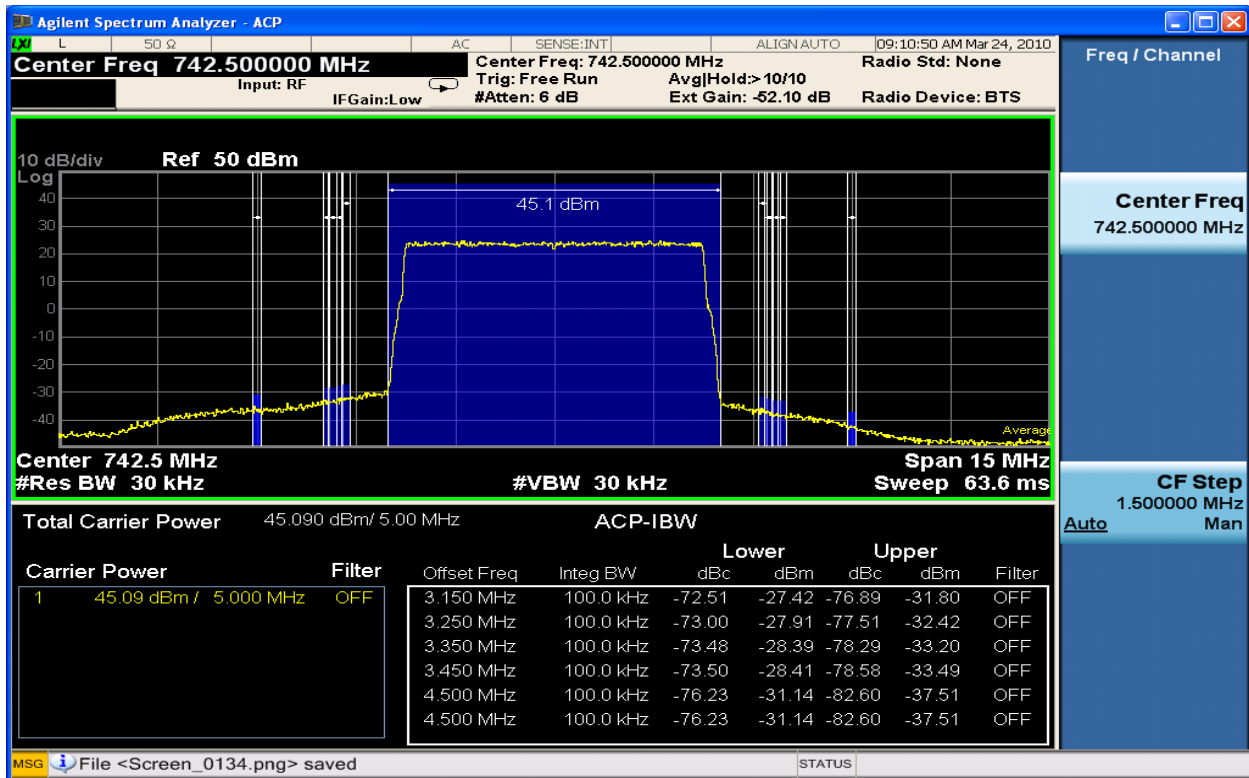

Figure 6-201 Spurious Emissions 742.5MHz TX1\_16QAM 5MHz Band Edge (ACP 650kHz – 2MHz)

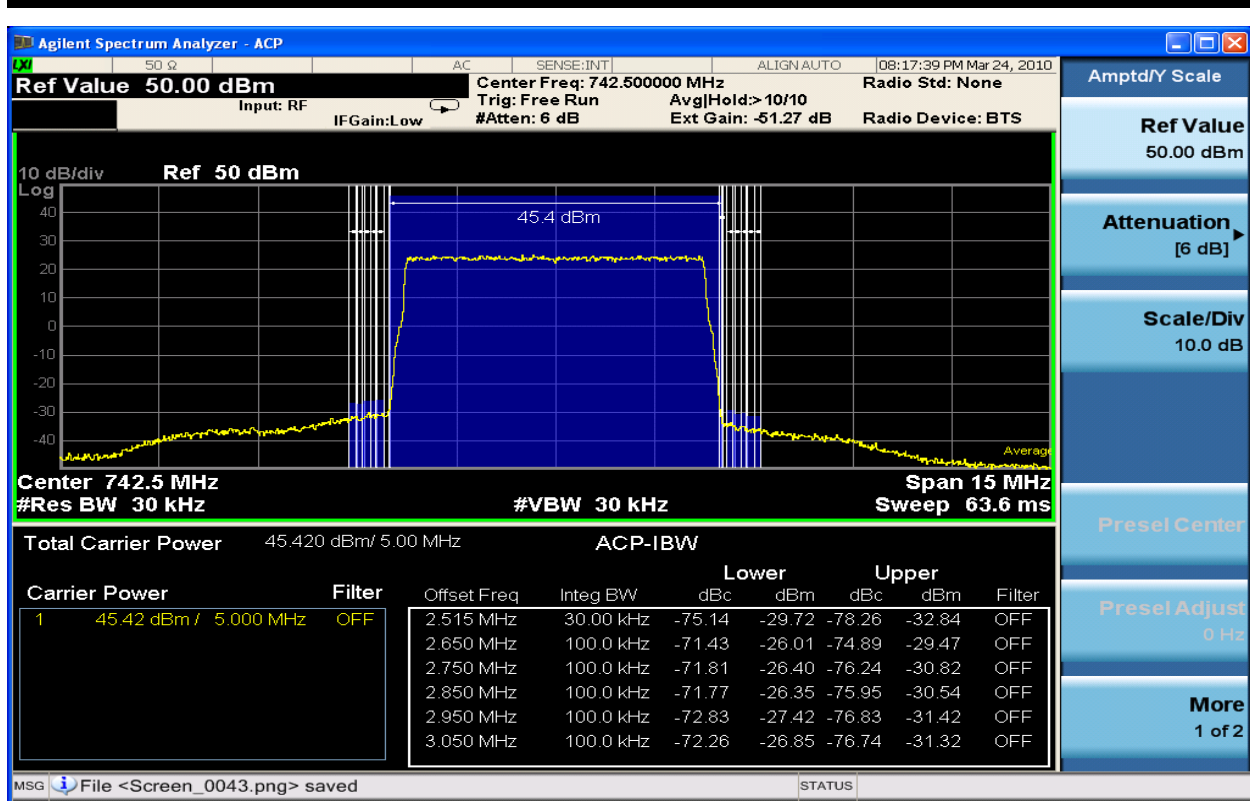

Figure 6-202 Spurious Emissions 742.5MHz TX2\_16QAM 5MHz Band Edge (ACP 15kHz – 550KHz)

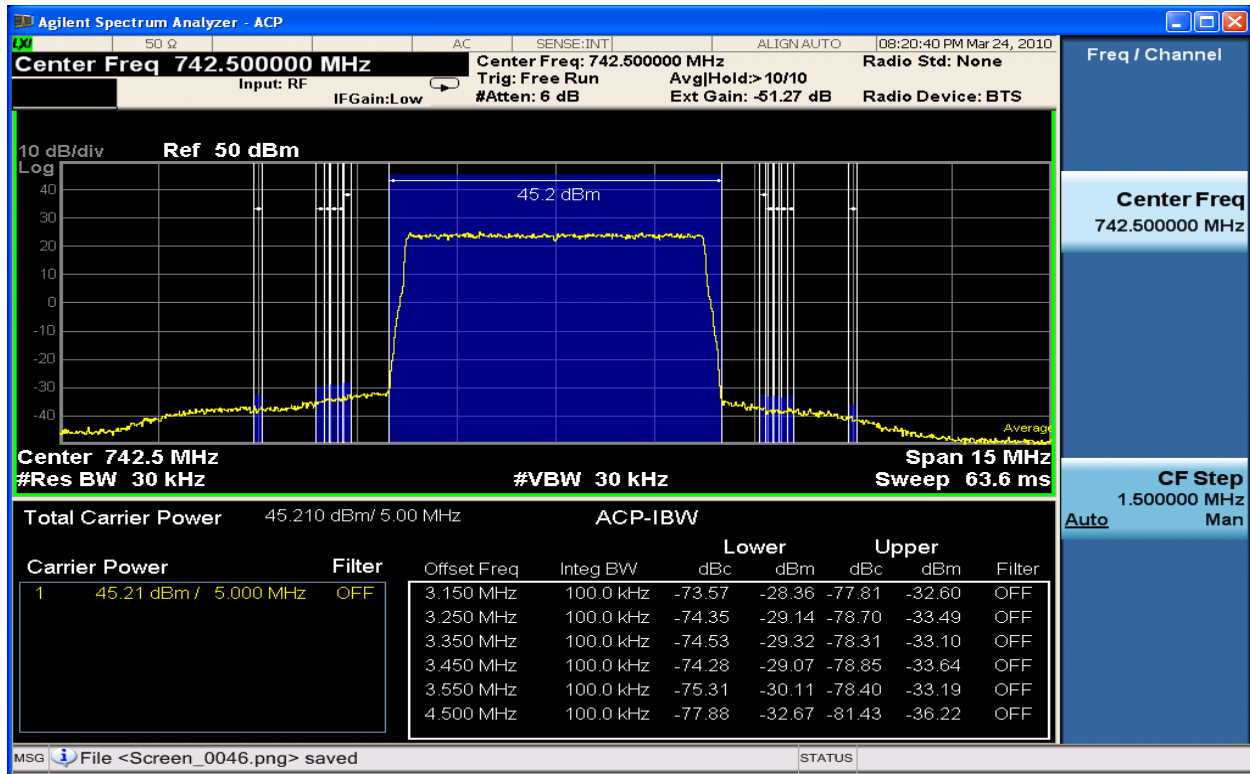

Figure 6-203 Spurious Emissions 742.5MHz TX2\_16QAM 5MHz Band Edge (ACP 650kHz – 2MHz)

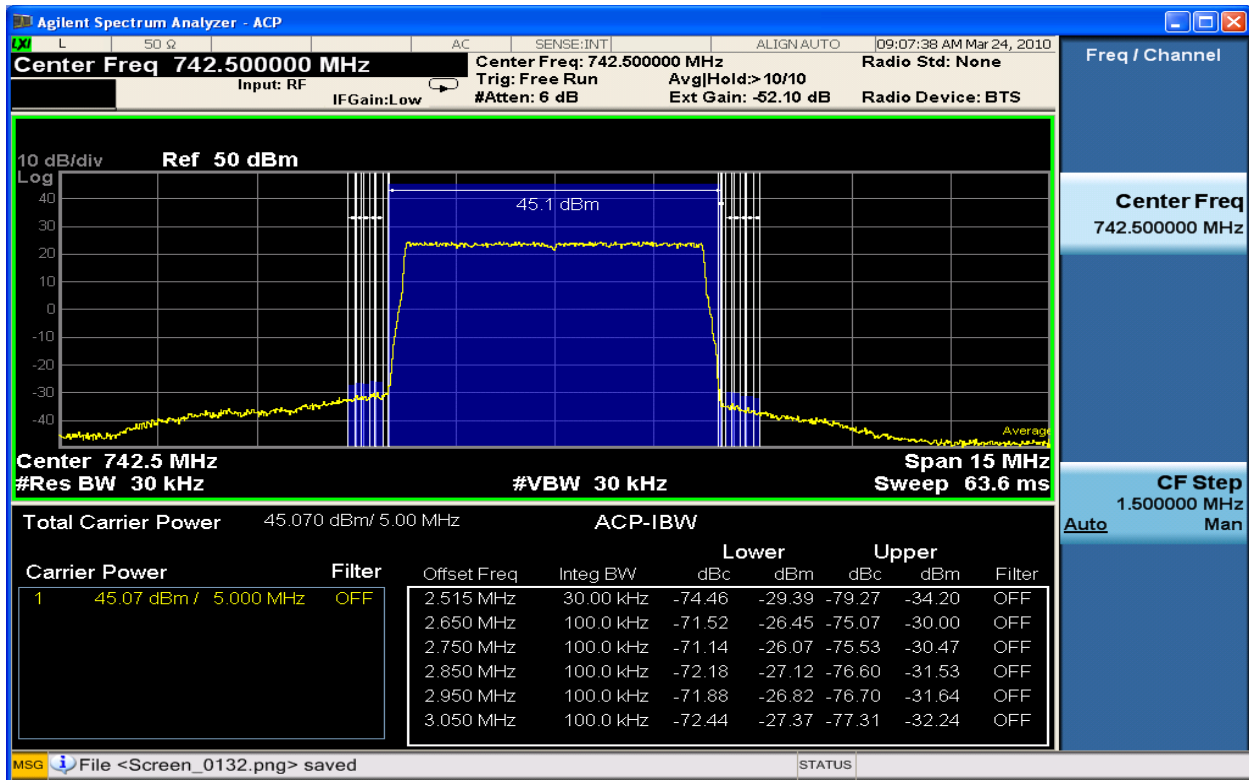

Figure 6-204 Spurious Emissions 742.5MHz TX1\_64QAM 5MHz Band Edge (ACP 15kHz – 550KHz)

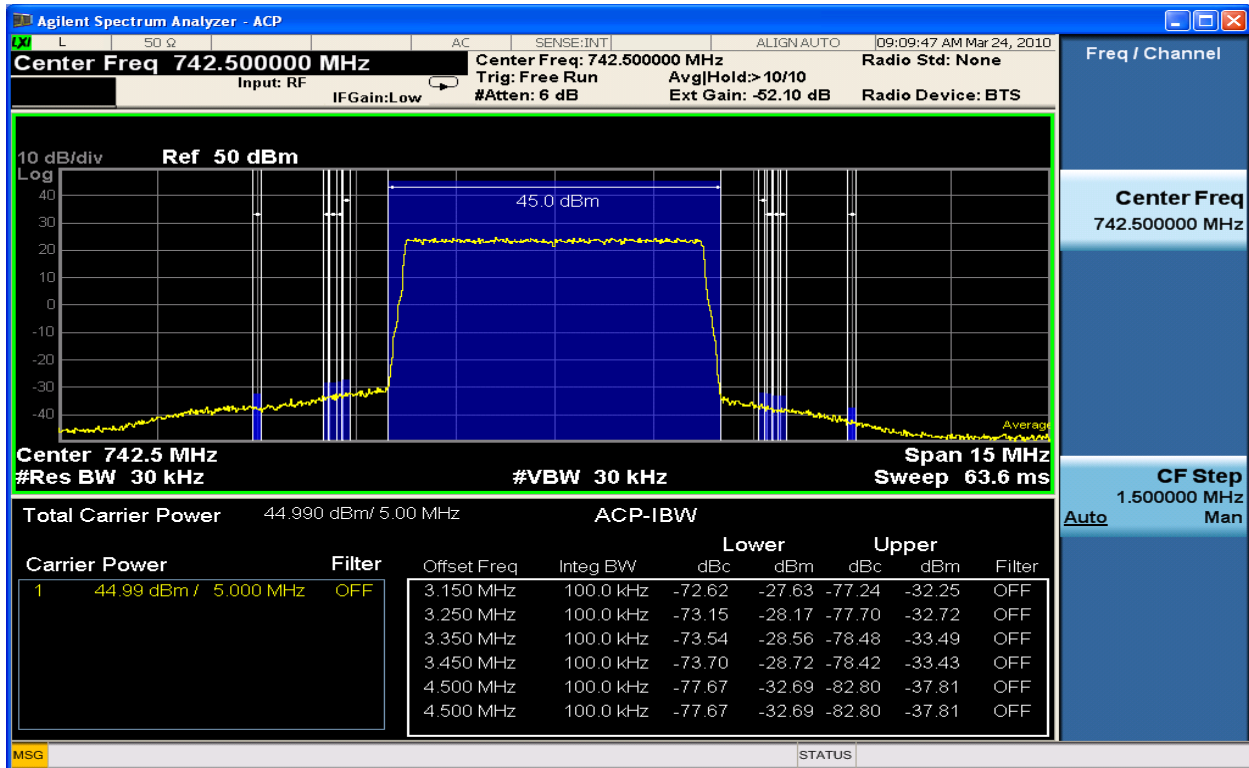

Figure 6-205 Spurious Emissions 742.5MHz TX1\_64QAM 5MHz Band Edge (ACP 650kHz – 2MHz)

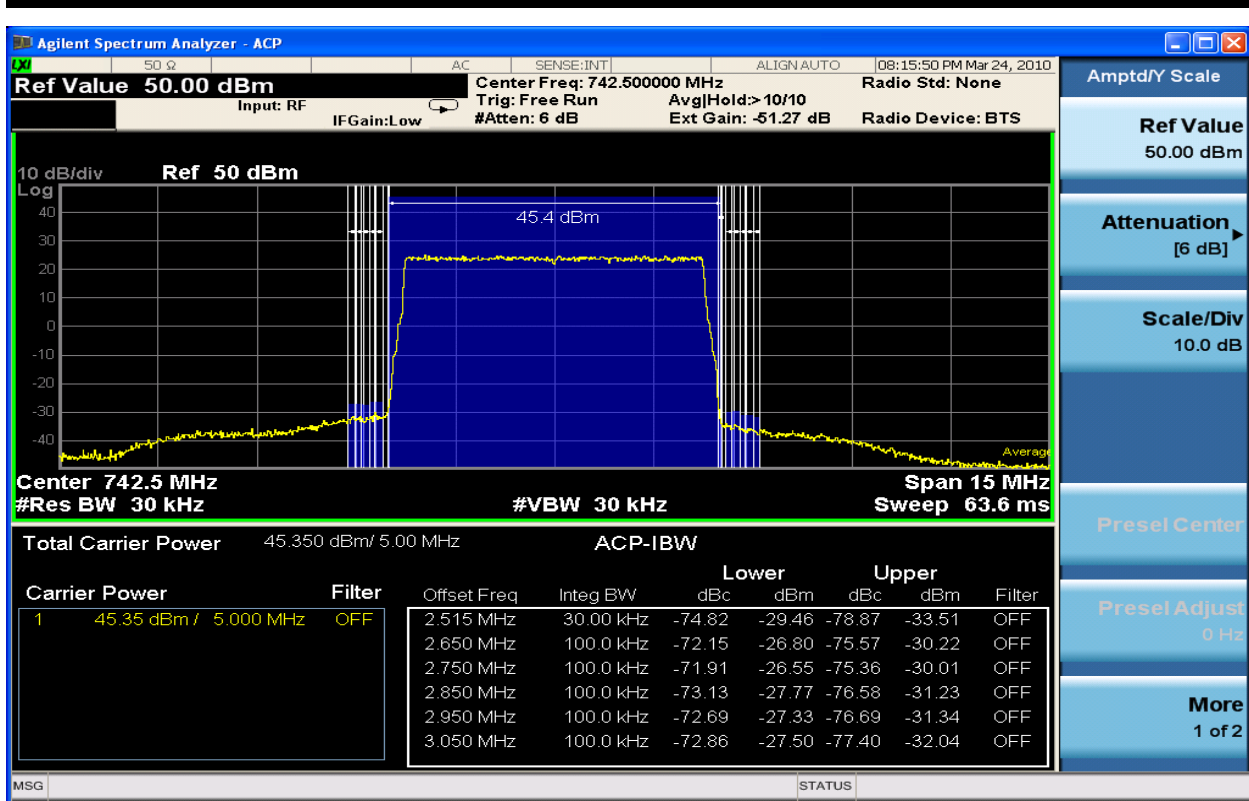

Figure 6-206 Spurious Emissions 742.5MHz TX2\_64QAM 5MHz Band Edge (ACP 15kHz – 550KHz)

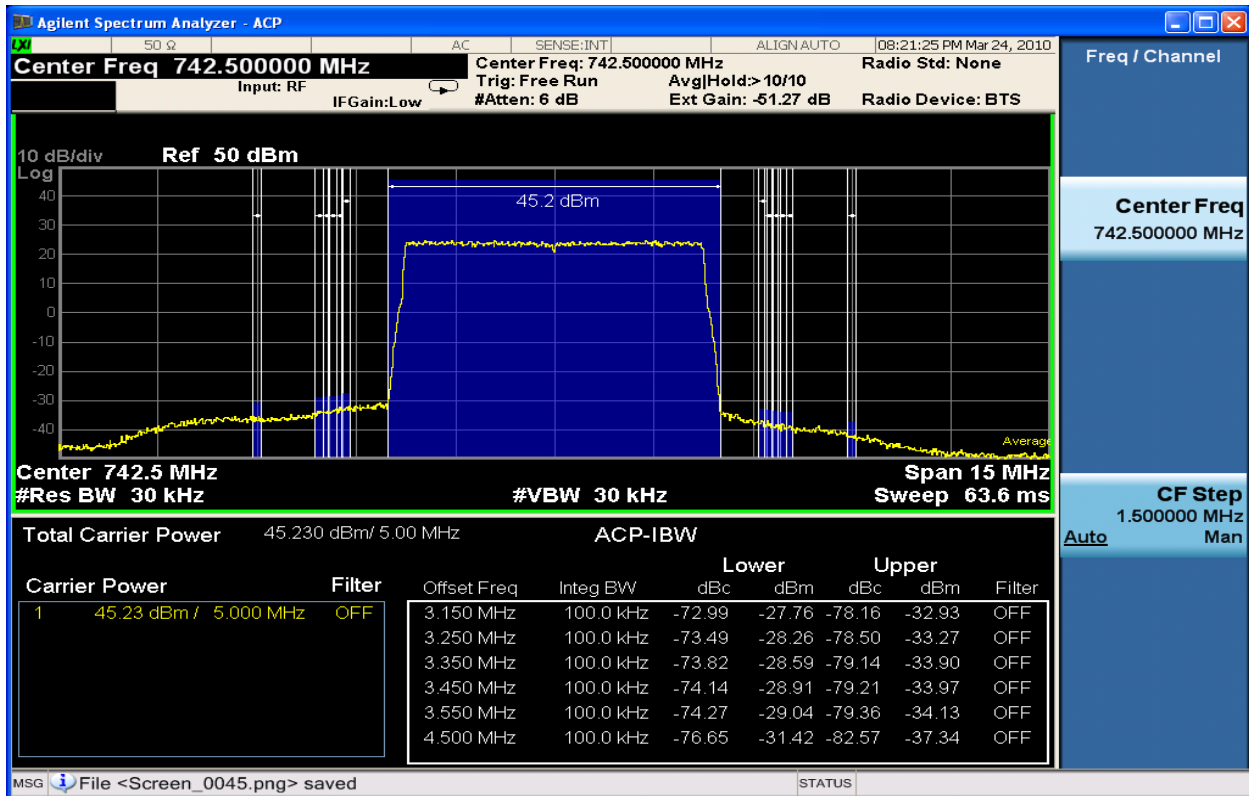

Figure 6-207 Spurious Emissions 742.5MHz TX2\_64QAM 5MHz Band Edge (ACP 650kHz – 2MHz)



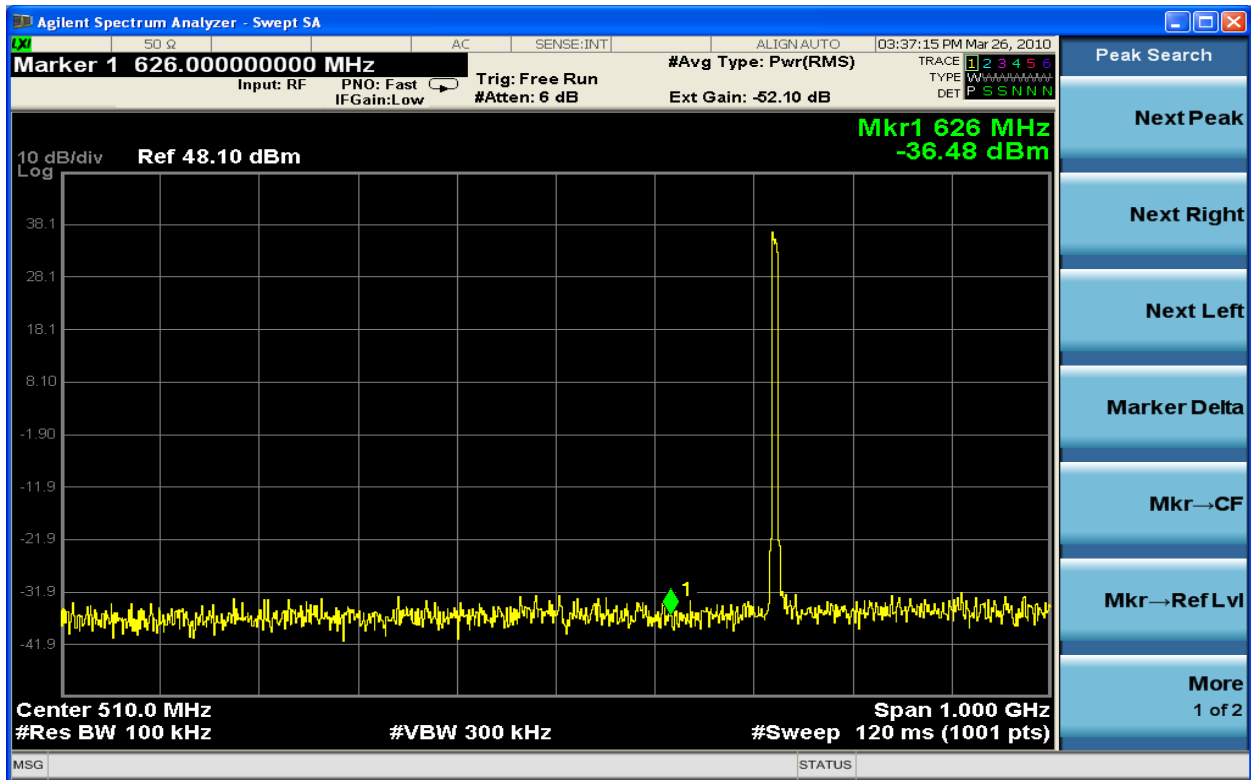

Figure 6-208 Spurious Emission TX1 QPSK 731.5MHz - 5MHz (10MHz-1.1GHz)

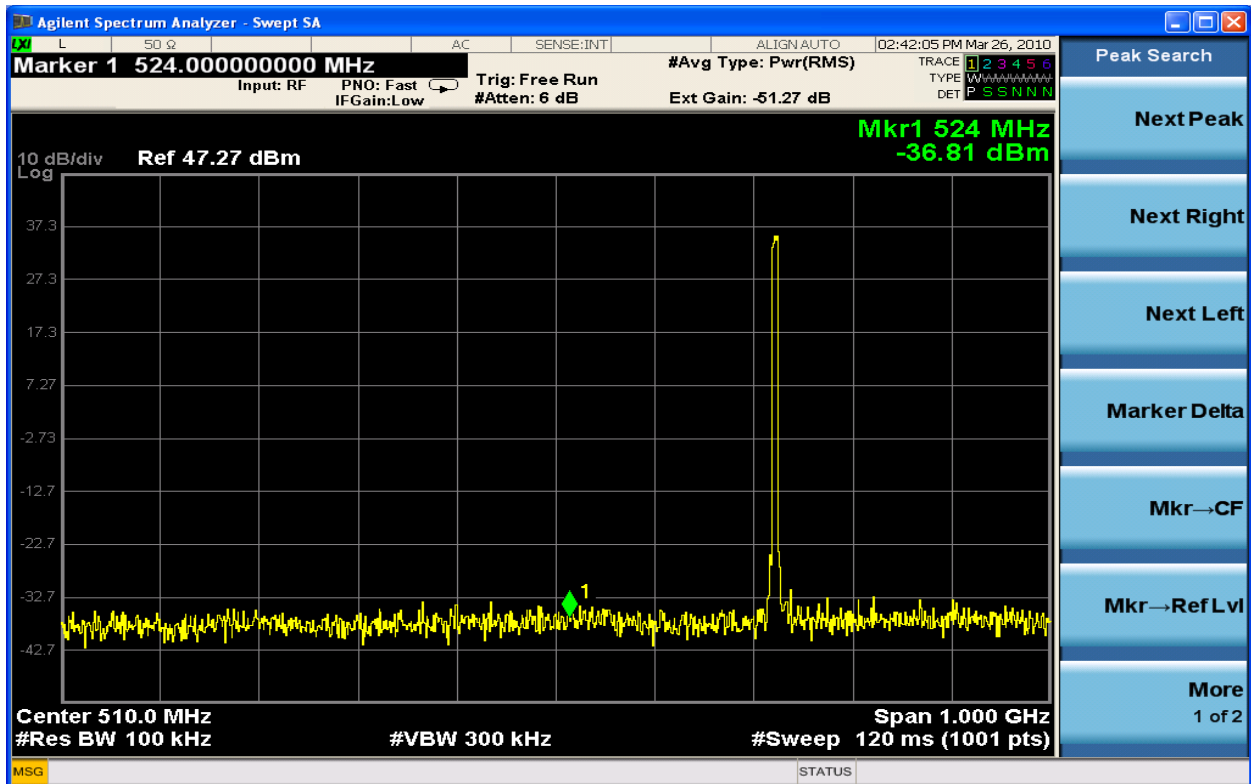

Figure 6-209 Spurious Emission TX2 QPSK 731.5MHz - 5MHz (10MHz-1.1GHz)

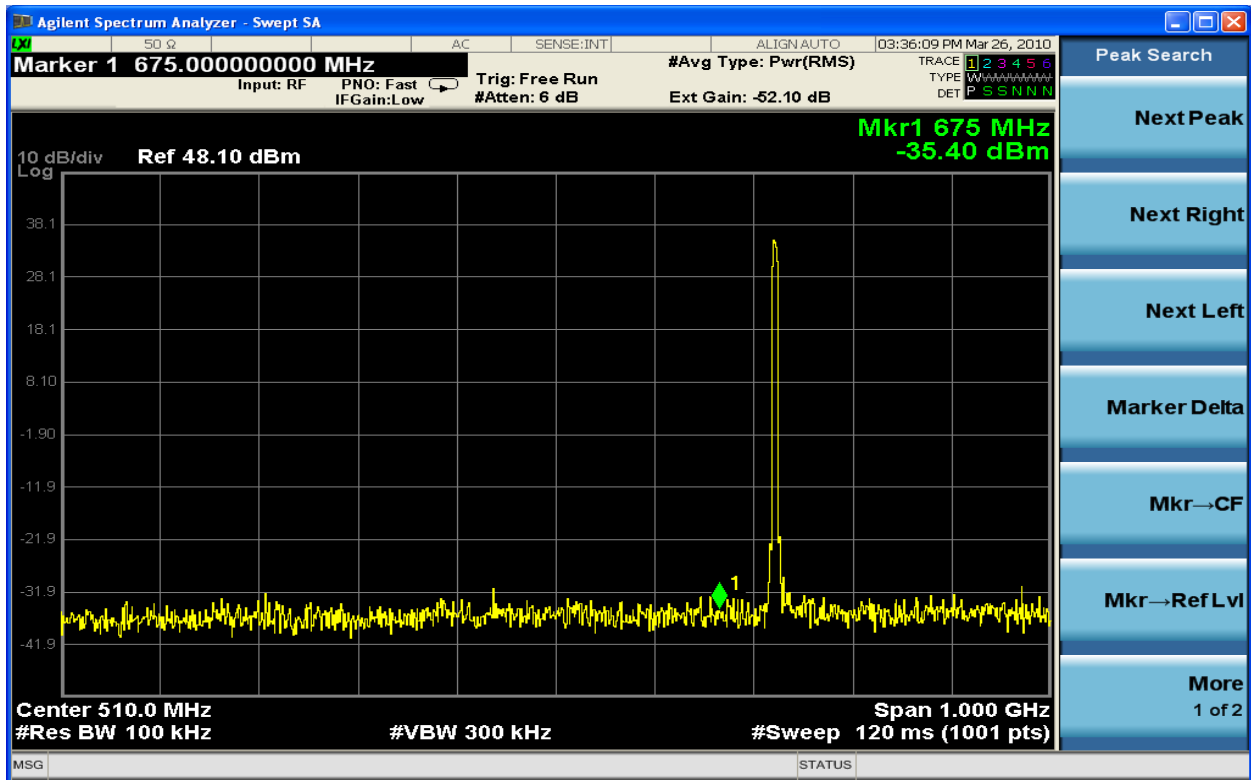

Figure 6-210 Spurious Emission TX1 16QAM 731.5MHz - 5MHz (10MHz-1.1GHz)

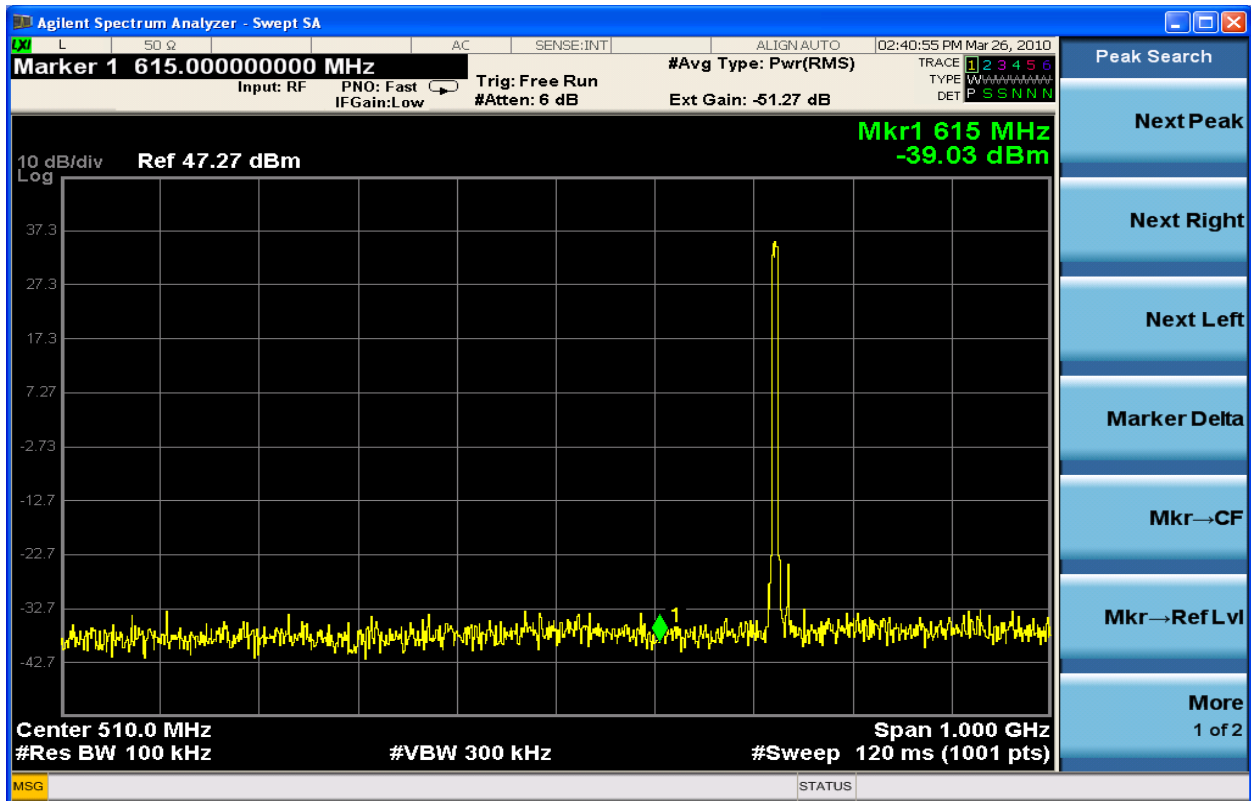

Figure 6-211 Spurious Emission TX2 16QAM 731.5MHz - 5MHz (10MHz-1.1GHz)

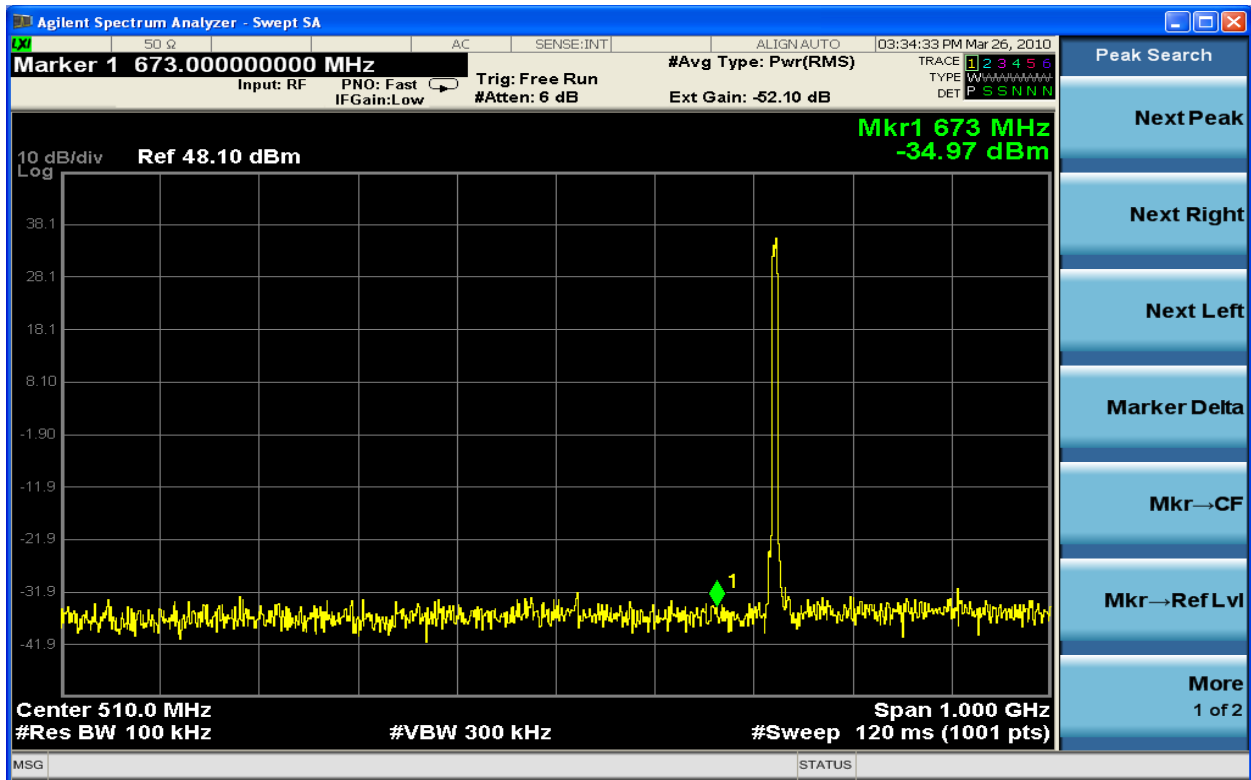

Figure 6-212 Spurious Emission TX1 64QAM 731.5MHz – 5MHz (10MHz-1.1GHz)

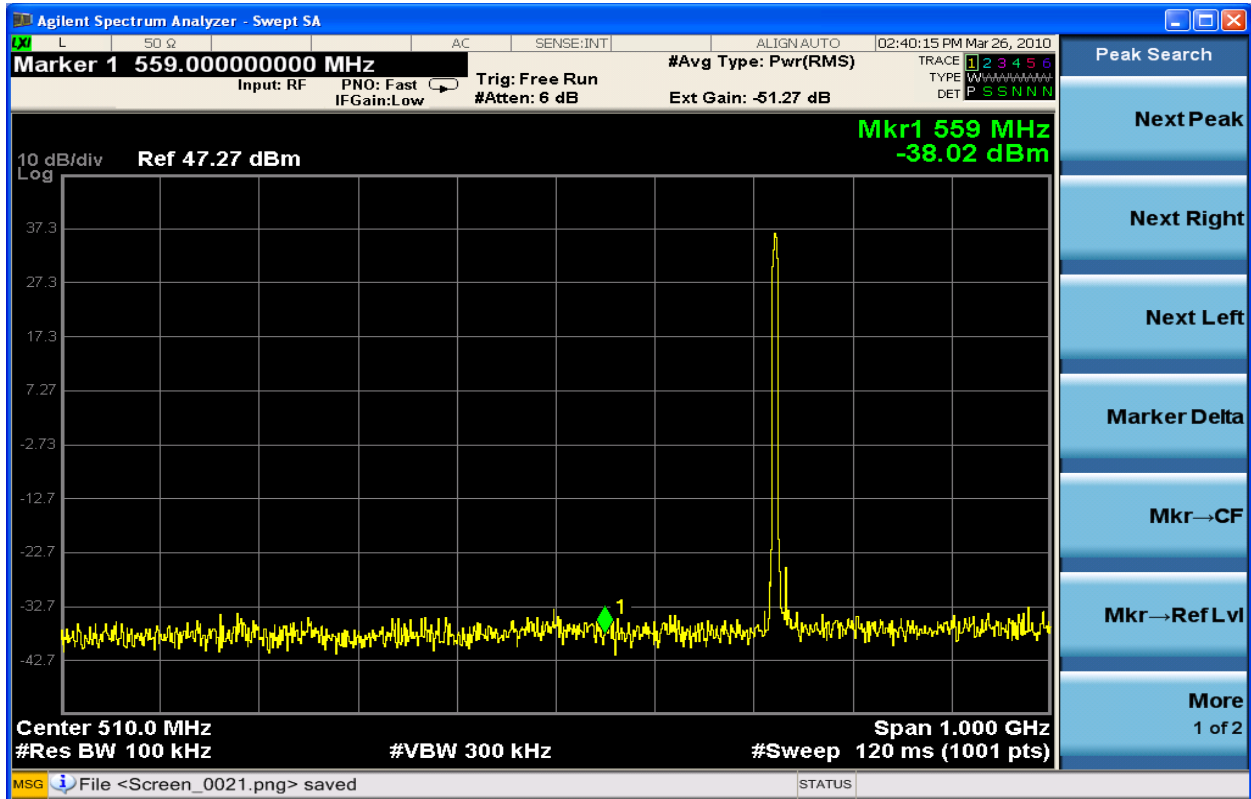

Figure 6-213 Spurious Emission TX2 64QAM 731.5MHz – 5MHz (10MHz-1.1GHz)

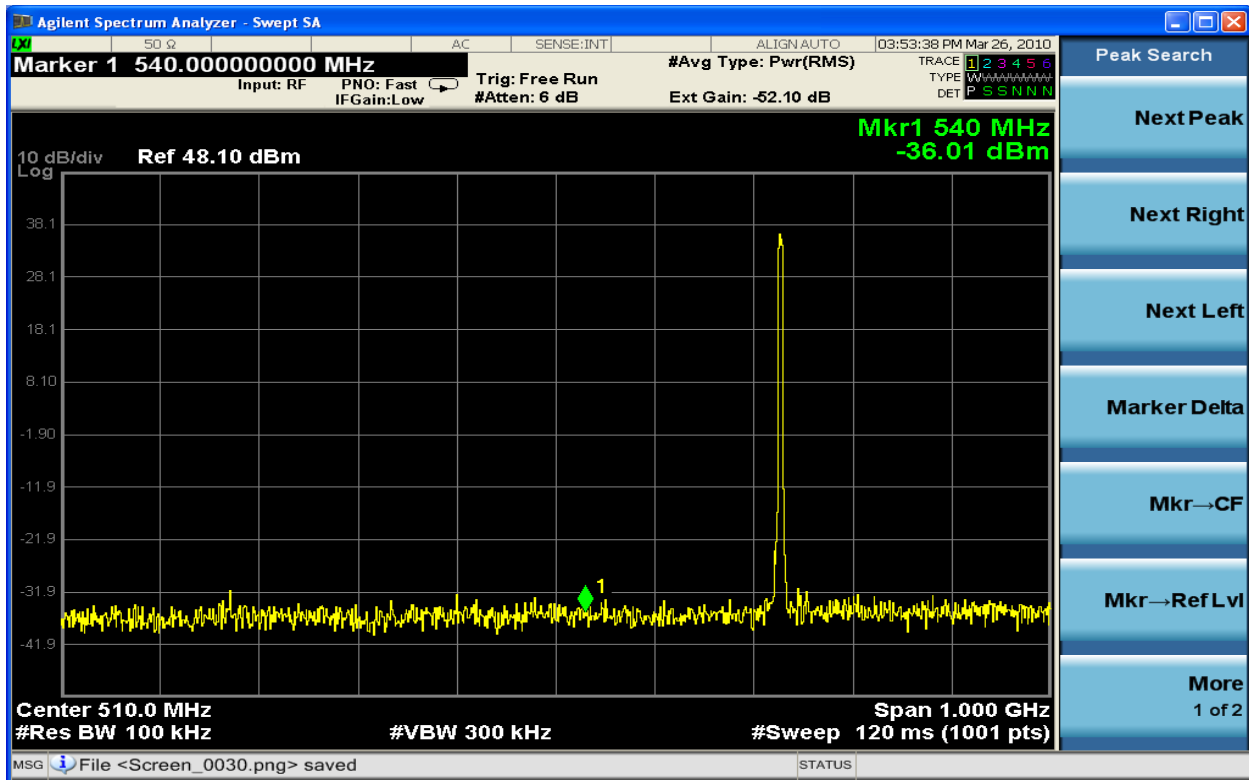

Figure 6-214 Spurious Emission TX1 QPSK 737MHz – 5MHz (10MHz-1.1GHz)

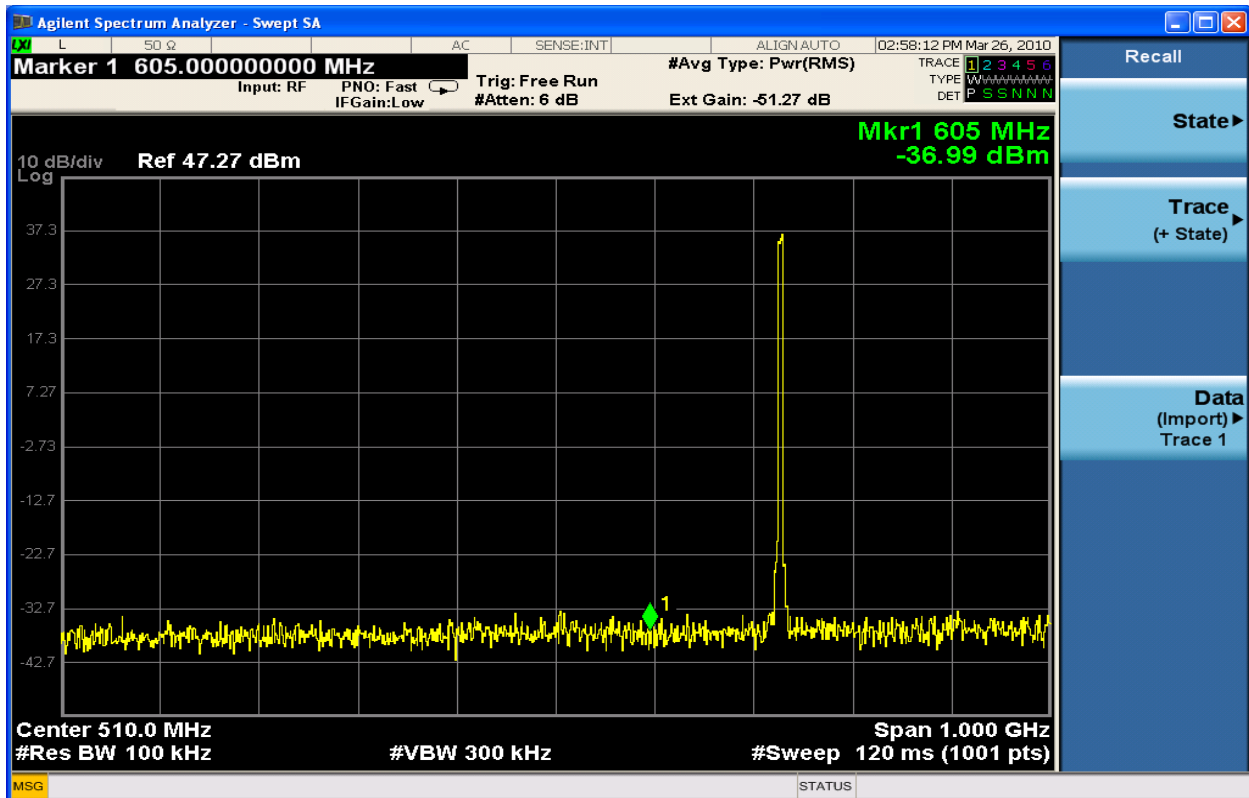

Figure 6-215 Spurious Emission TX2 QPSK 737MHz – 5MHz (10MHz-1.1GHz)

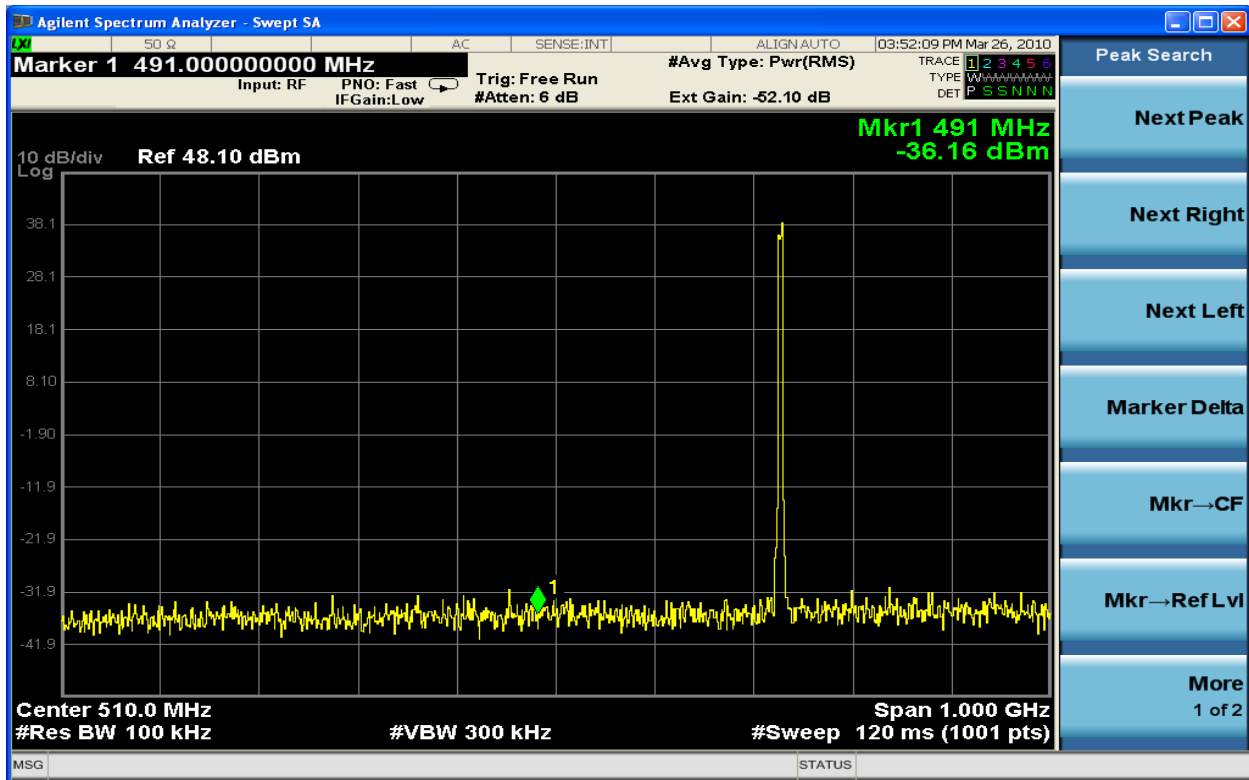

Figure 6-216 Spurious Emission TX1 16QAM 737MHz – 5MHz (10MHz-1.1GHz)

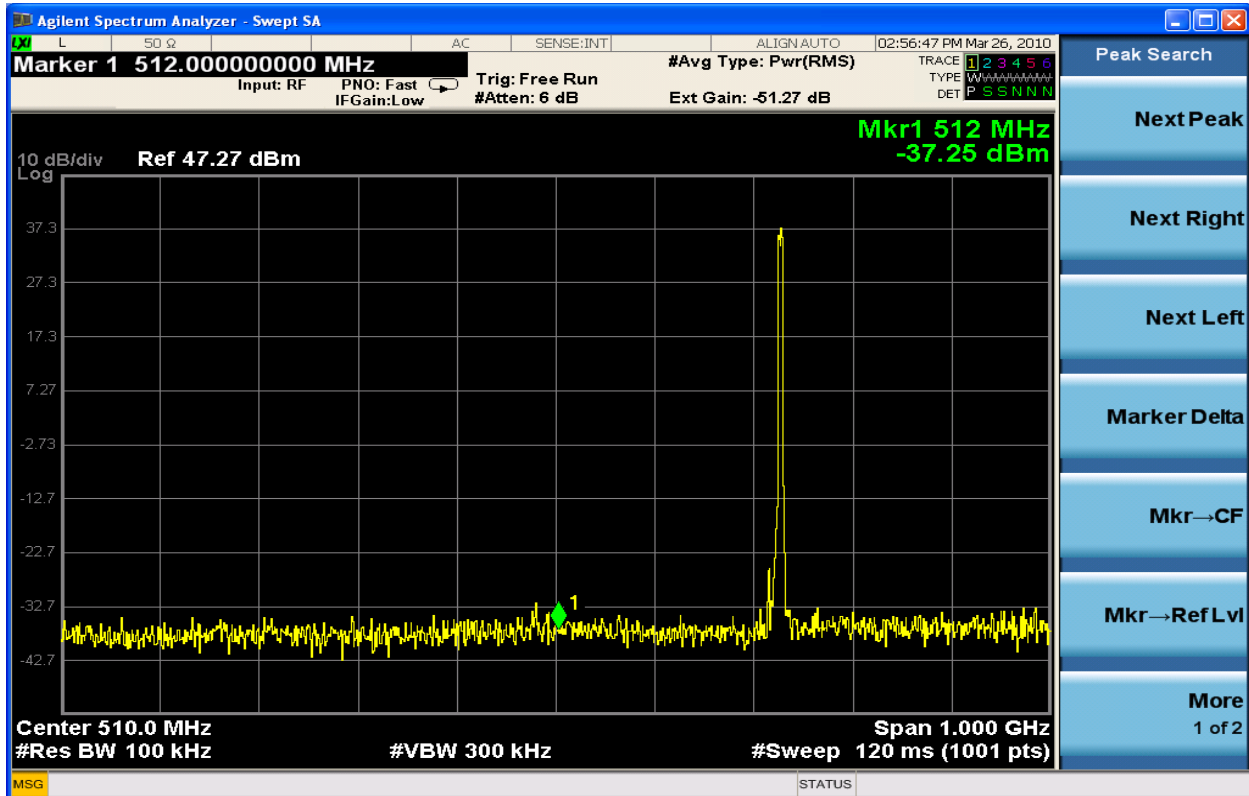

Figure 6-217 Spurious Emission TX2 16QAM 737MHz – 5MHz (10MHz-1.1GHz)

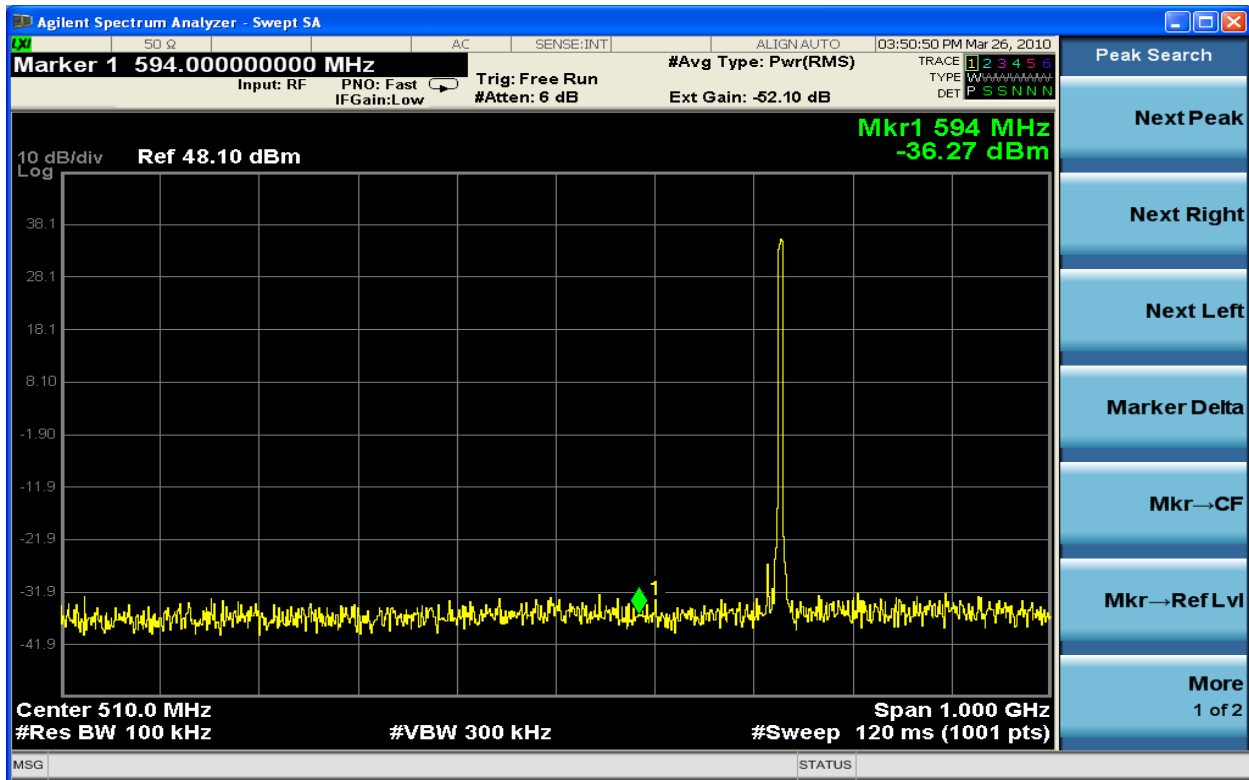

Figure 6-218 Spurious Emission TX1 64QAM 737MHz – 5MHz (10MHz-1.1GHz)

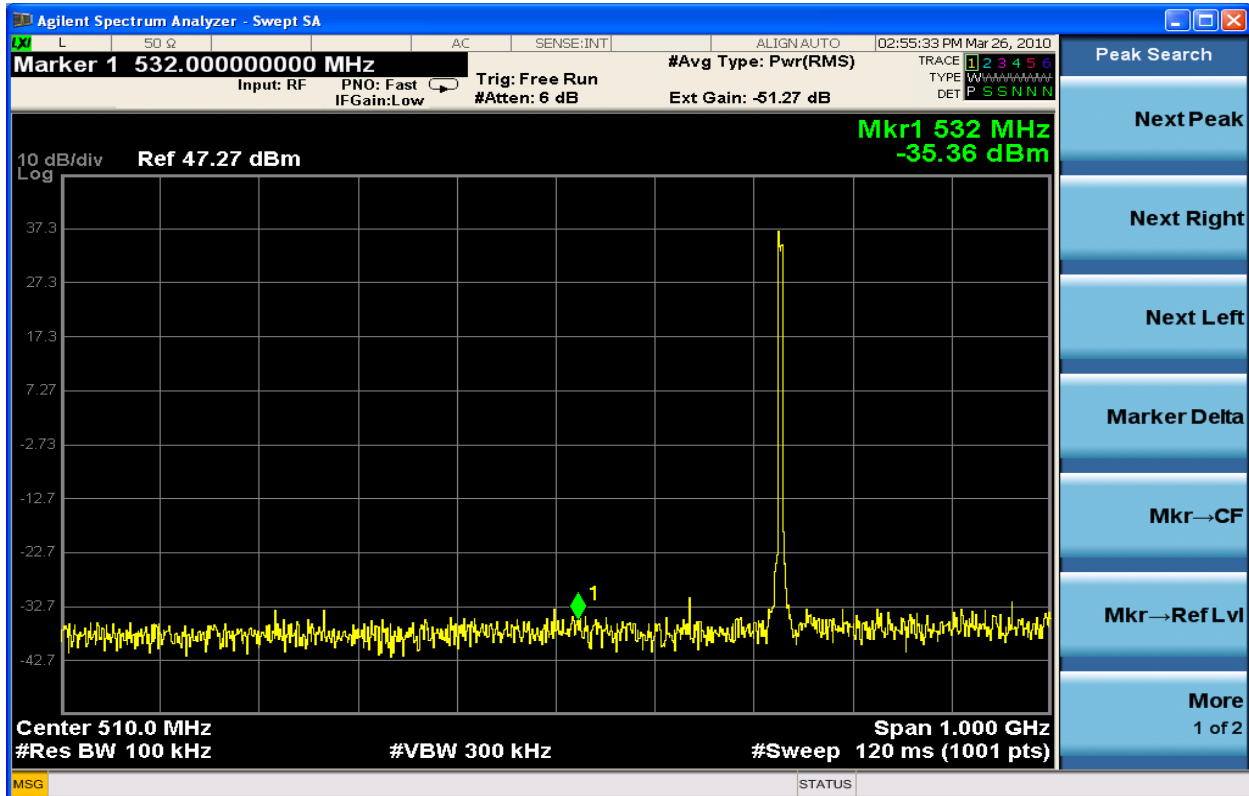

Figure 6-219 Spurious Emission TX2 64QAM 737MHz – 5MHz (10MHz-1.1GHz)

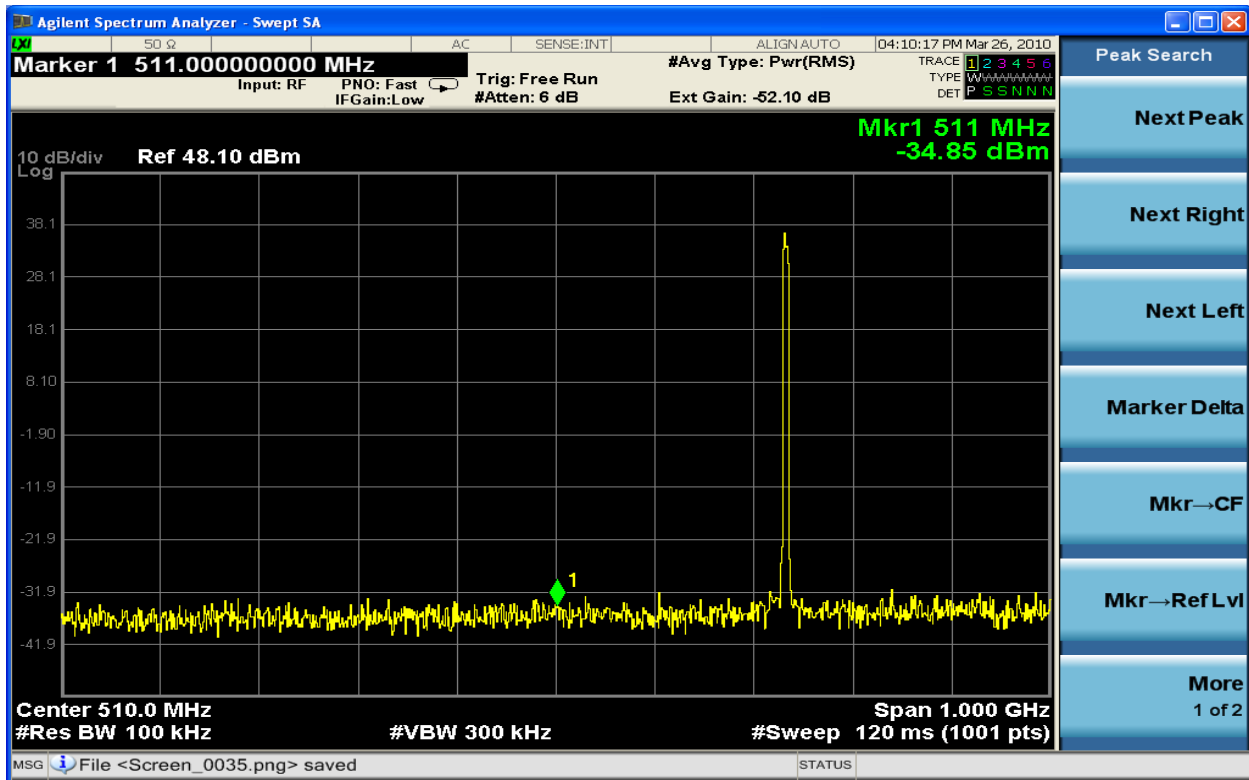

Figure 6-220 Spurious Emission TX1 QPSK 742.5MHz – 5MHz (10MHz-1.1GHz)

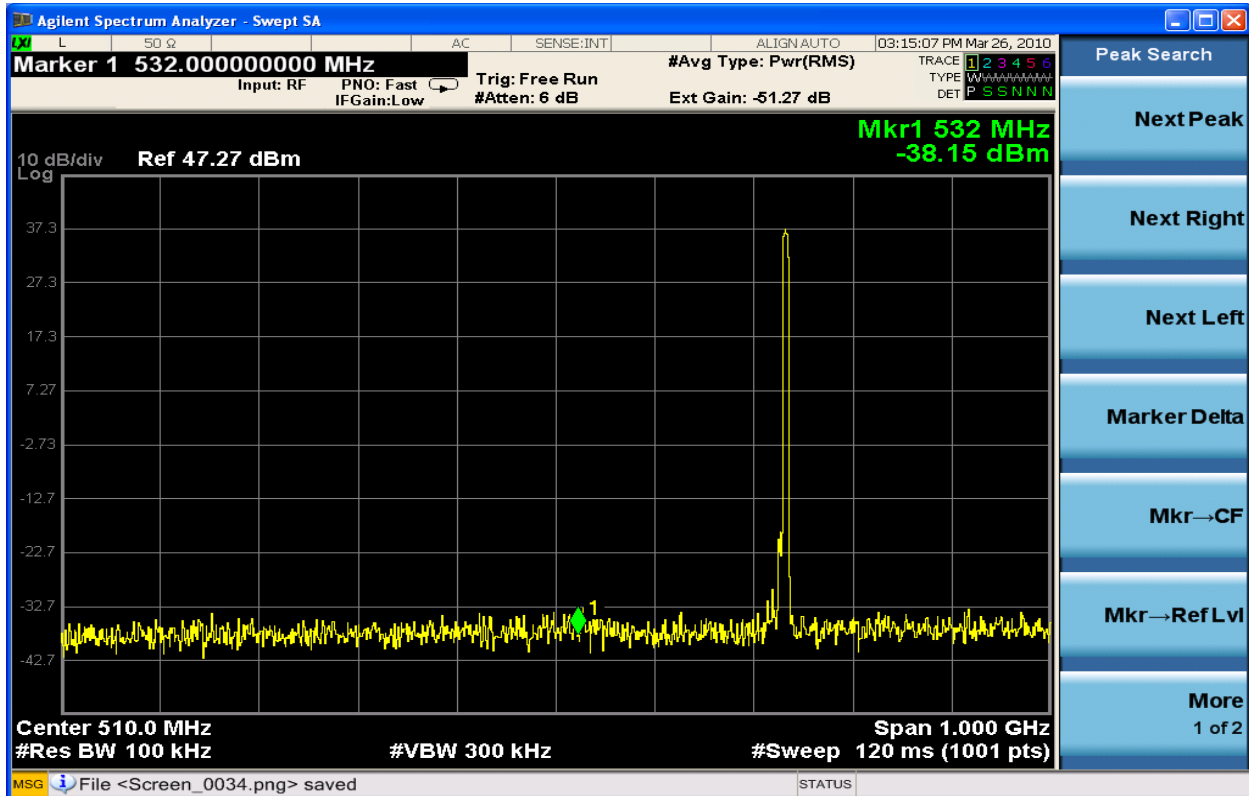

Figure 6-221 Spurious Emission TX2 QPSK 742.5MHz – 5MHz (10MHz-1.1GHz)

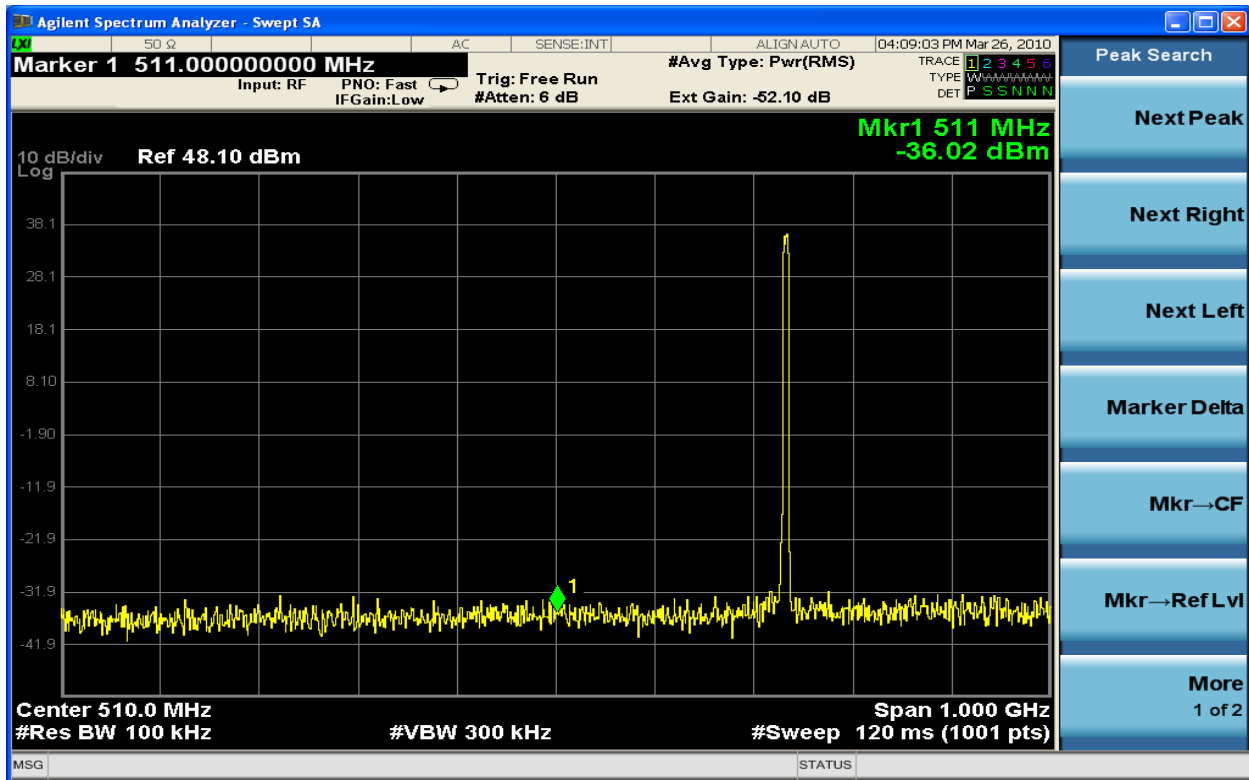

Figure 6-222 Spurious Emission TX1 16QAM 742.5MHz – 5MHz (10MHz-1.1GHz)

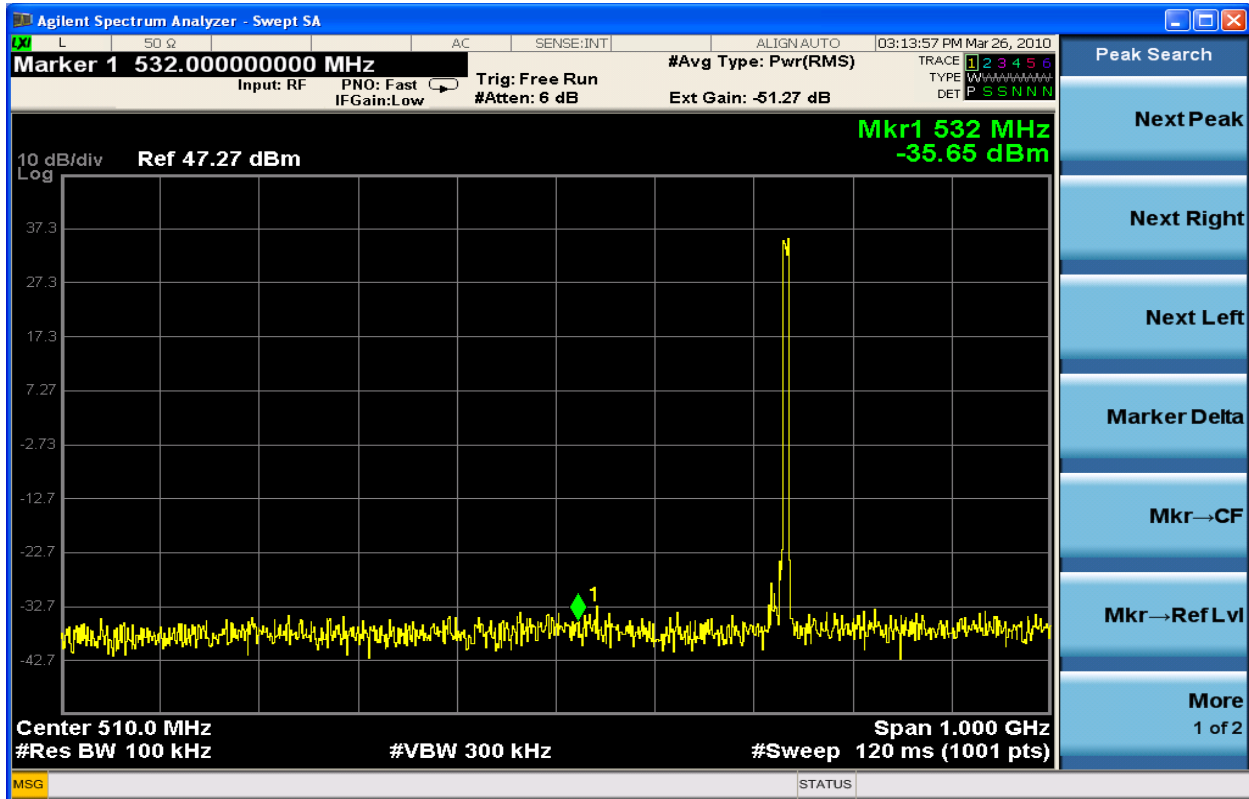

Figure 6-223 Spurious Emission TX2 16QAM 742.5MHz – 5MHz (10MHz-1.1GHz)



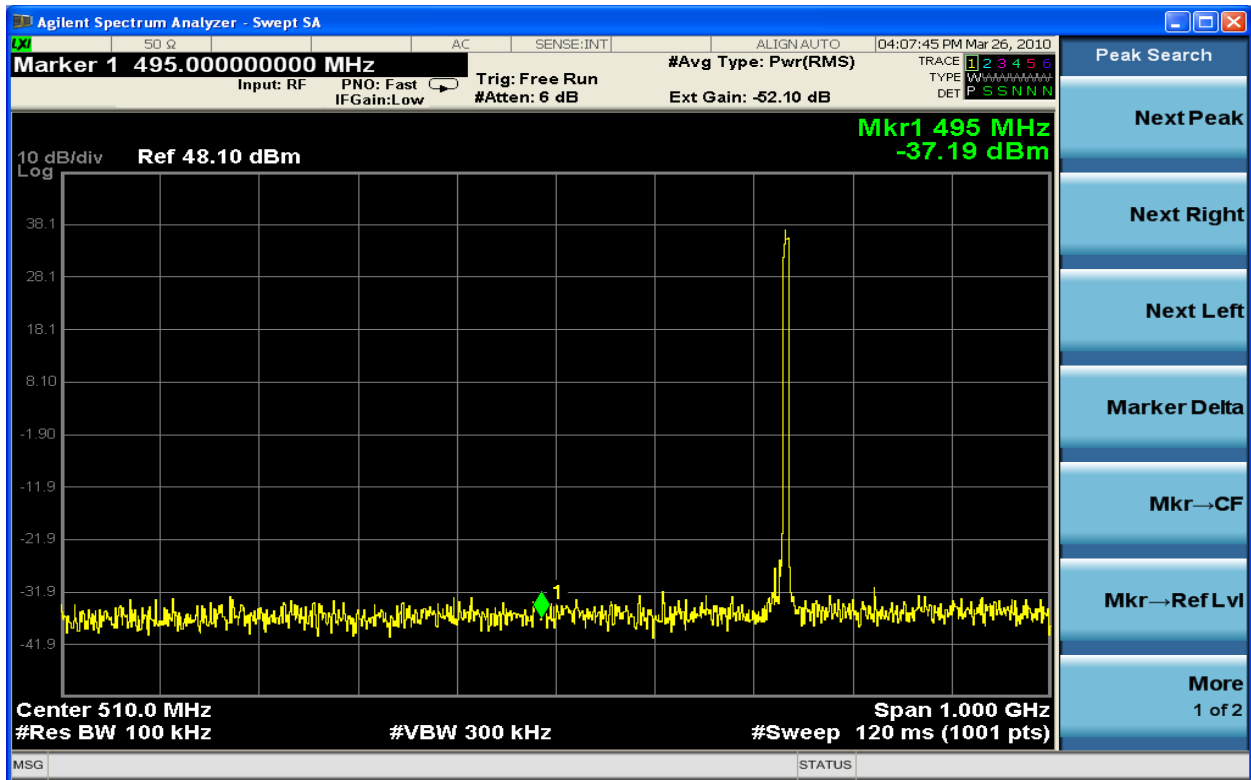

Figure 6-224 Spurious Emission TX1 64QAM 742.5MHz – 5MHz (10MHz-1.1GHz)

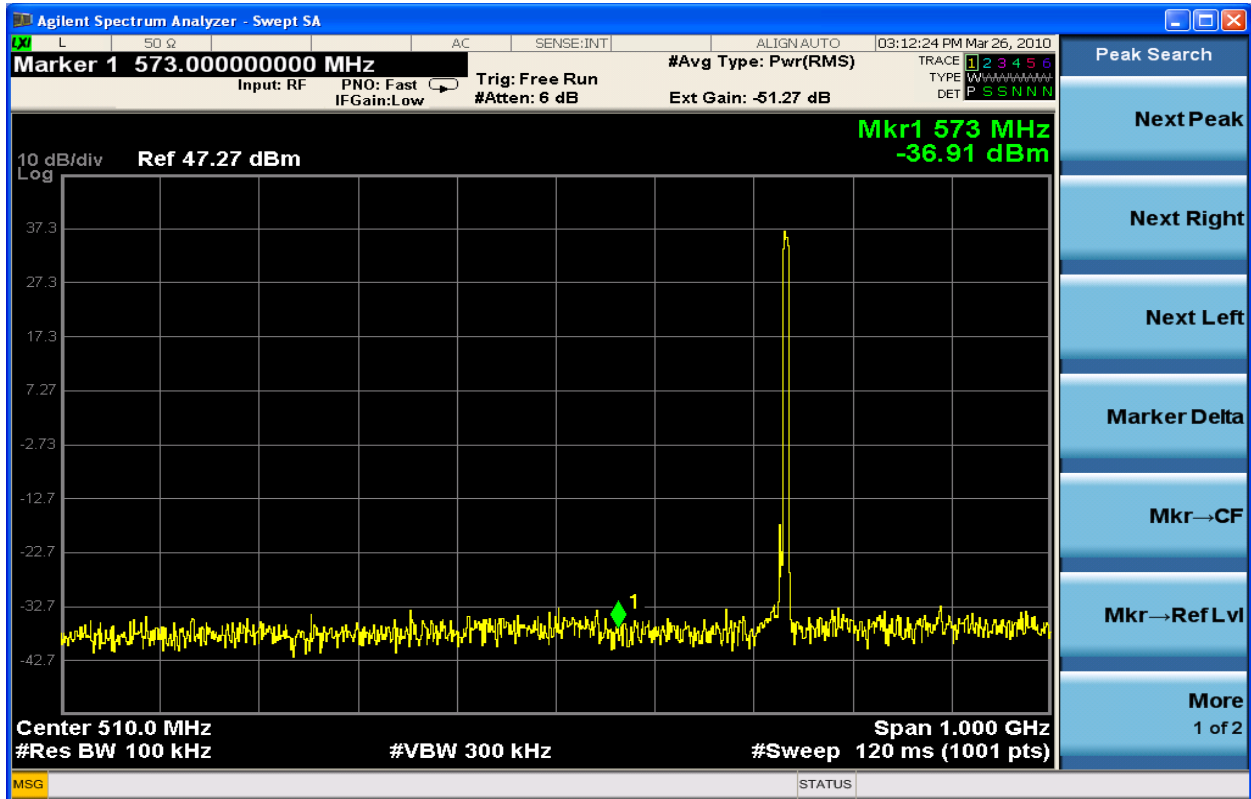

Figure 6-225 Spurious Emission TX2 64QAM 742.5MHz – 5MHz (10MHz-1.1GHz)

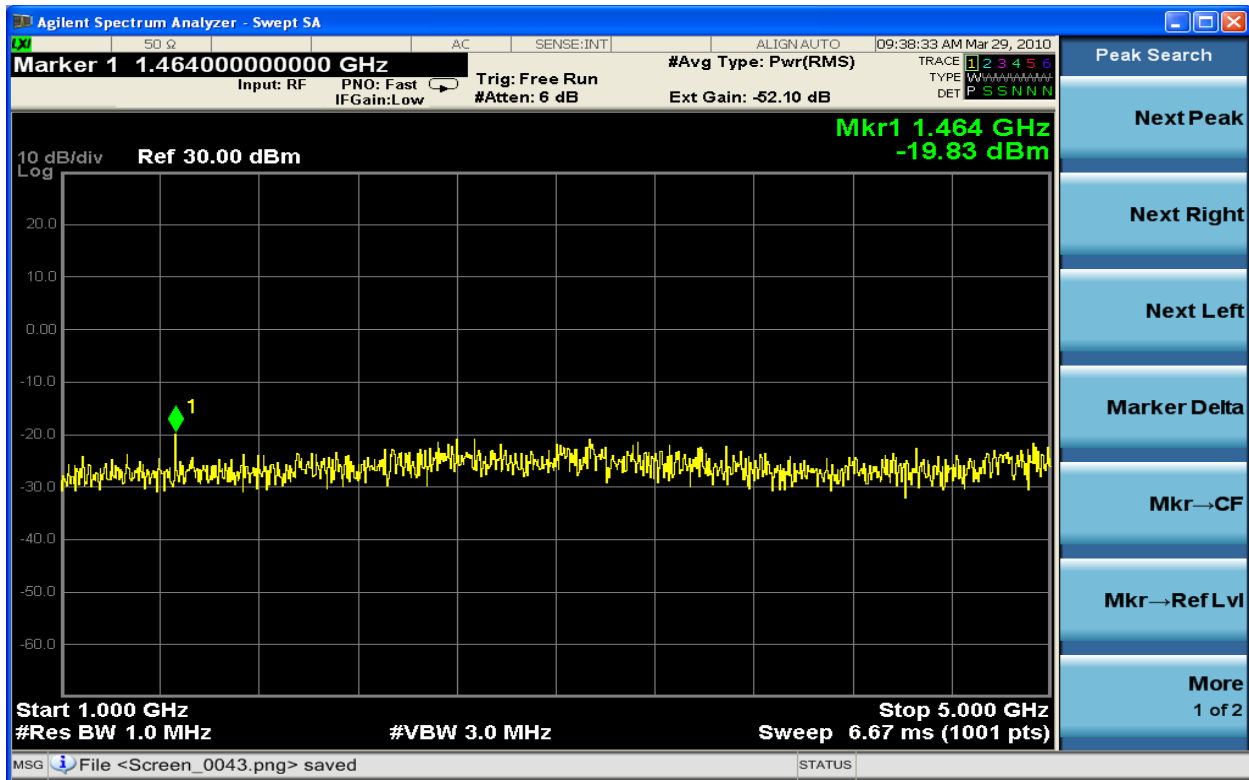

Figure 6-226 Spurious Emission TX1 QPSK 731.5MHz – 5MHz (1GHz - 5GHz)

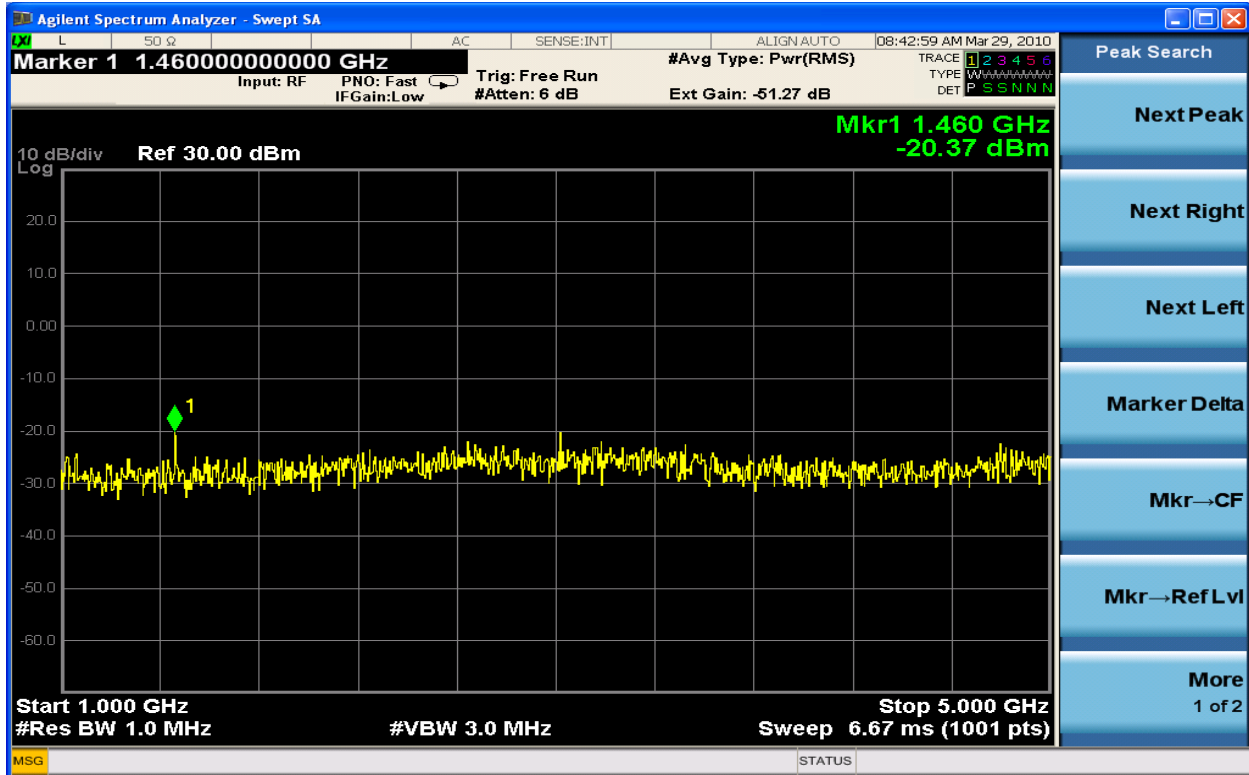

Figure 6-227 Spurious Emission TX2 QPSK 731.5MHz – 5MHz (1GHz - 5GHz)

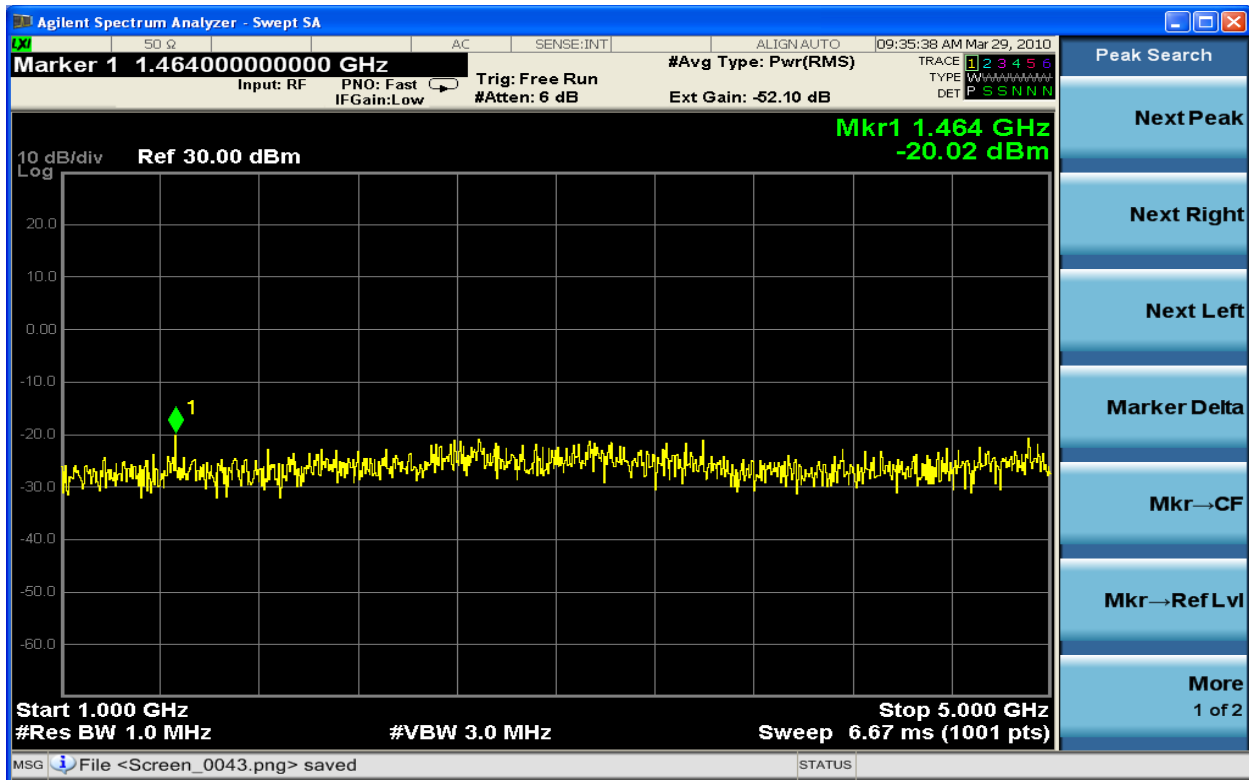

Figure 6-228 Spurious Emission TX1 16QAM 731.5MHz – 5MHz (1GHz - 5GHz)

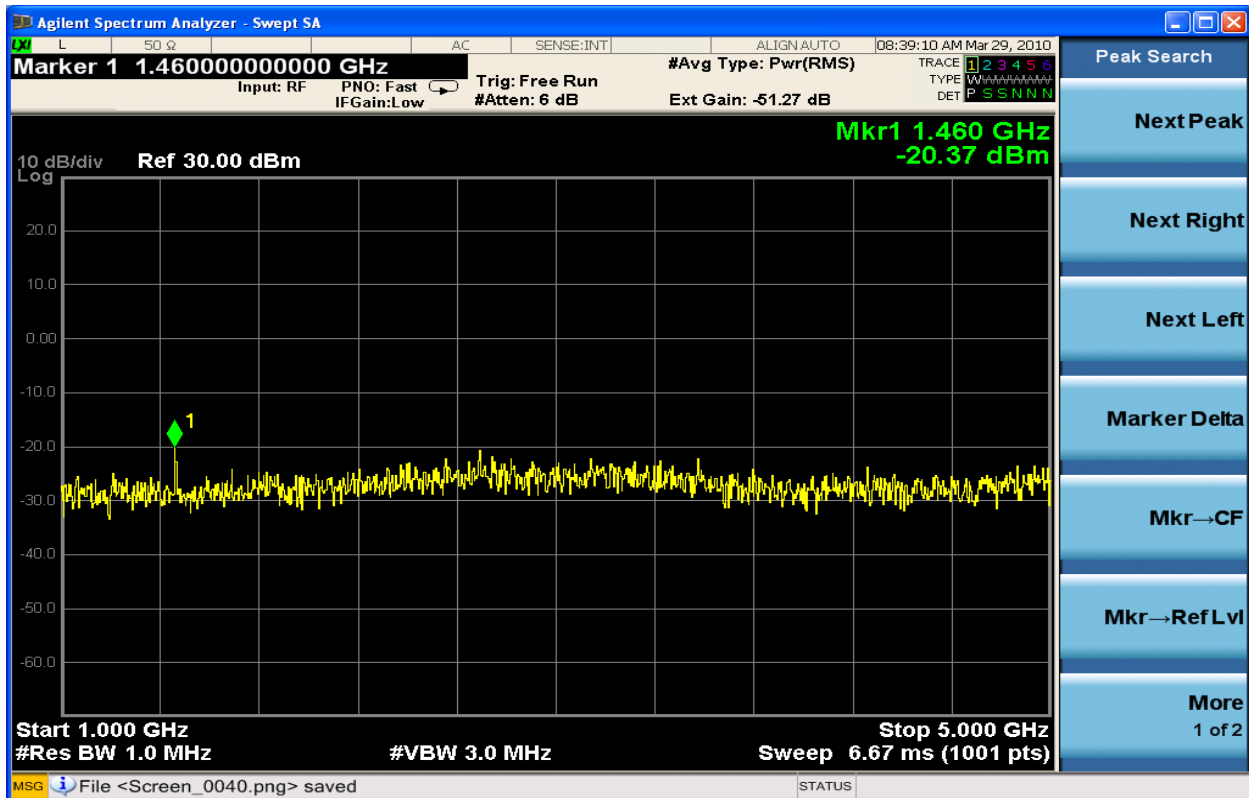

Figure 6-229 Spurious Emission TX2 16QAM 731.5MHz – 5MHz (1GHz - 5GHz)

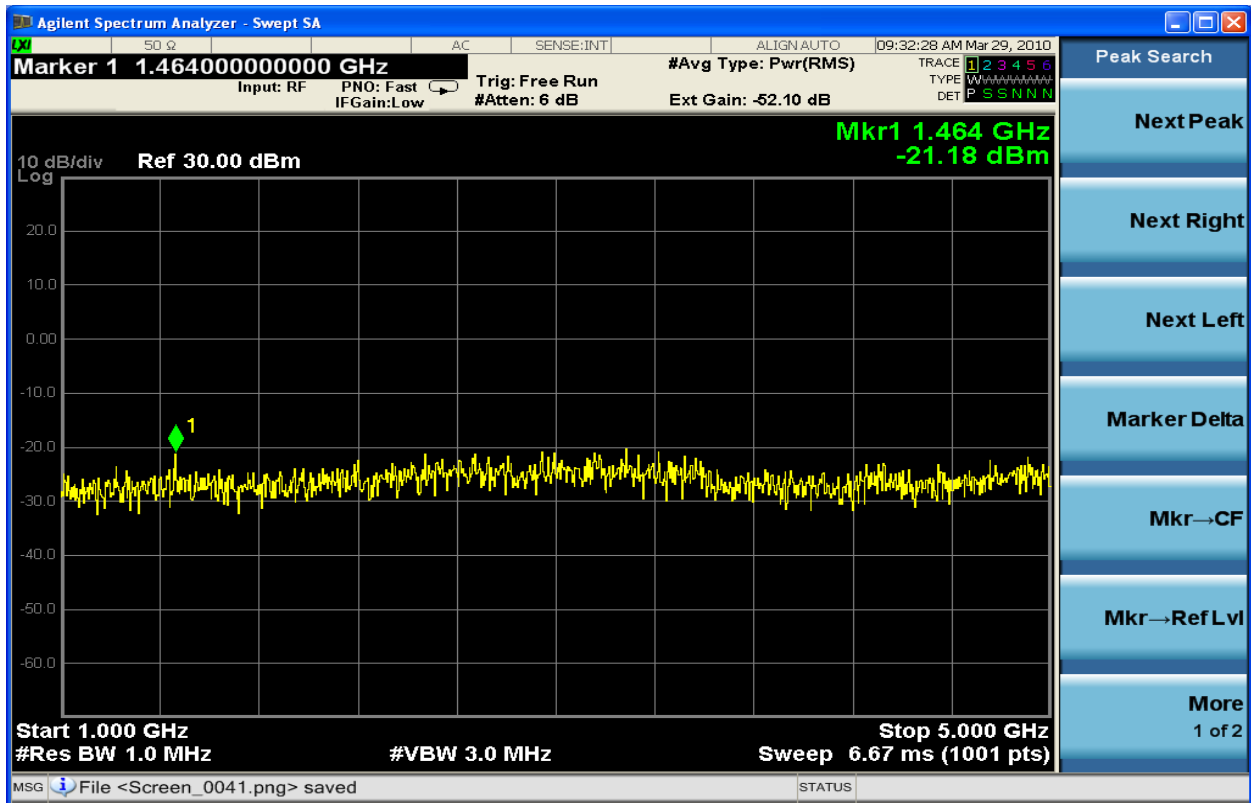

Figure 6-230 Spurious Emission TX1 64QAM 731.5MHz – 5MHz (1GHz - 5GHz)

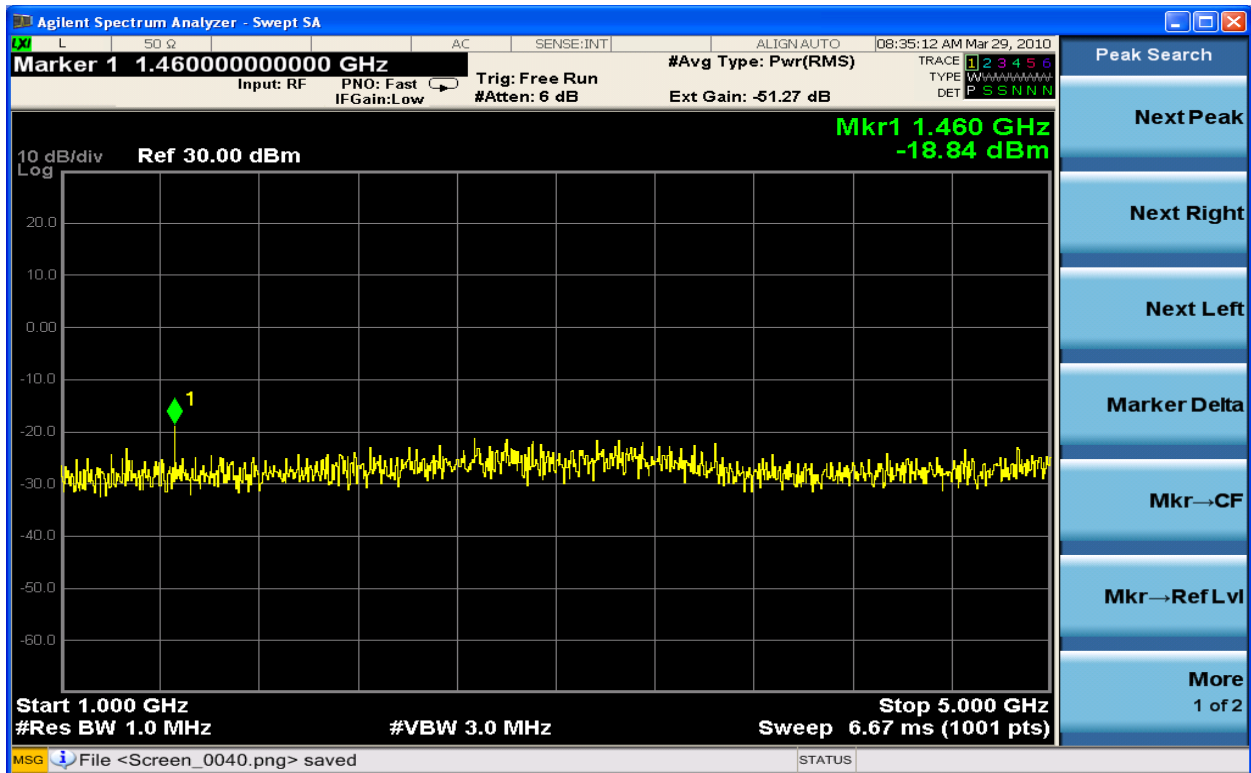

Figure 6-231 Spurious Emission TX2 64QAM 731.5MHz – 5MHz (1GHz - 5GHz)

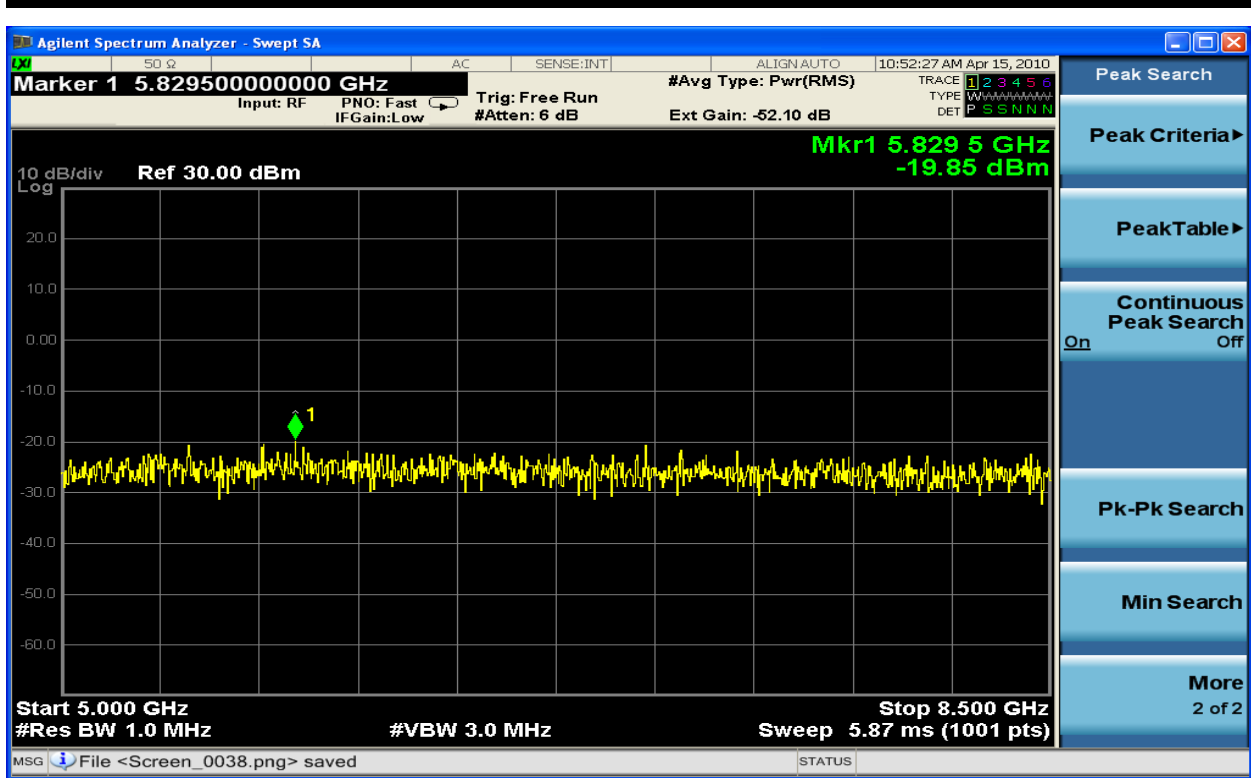

Figure 6-232 Spurious Emission TX1 QPSK 731.5MHz – 5MHz (5GHz - 8GHz)

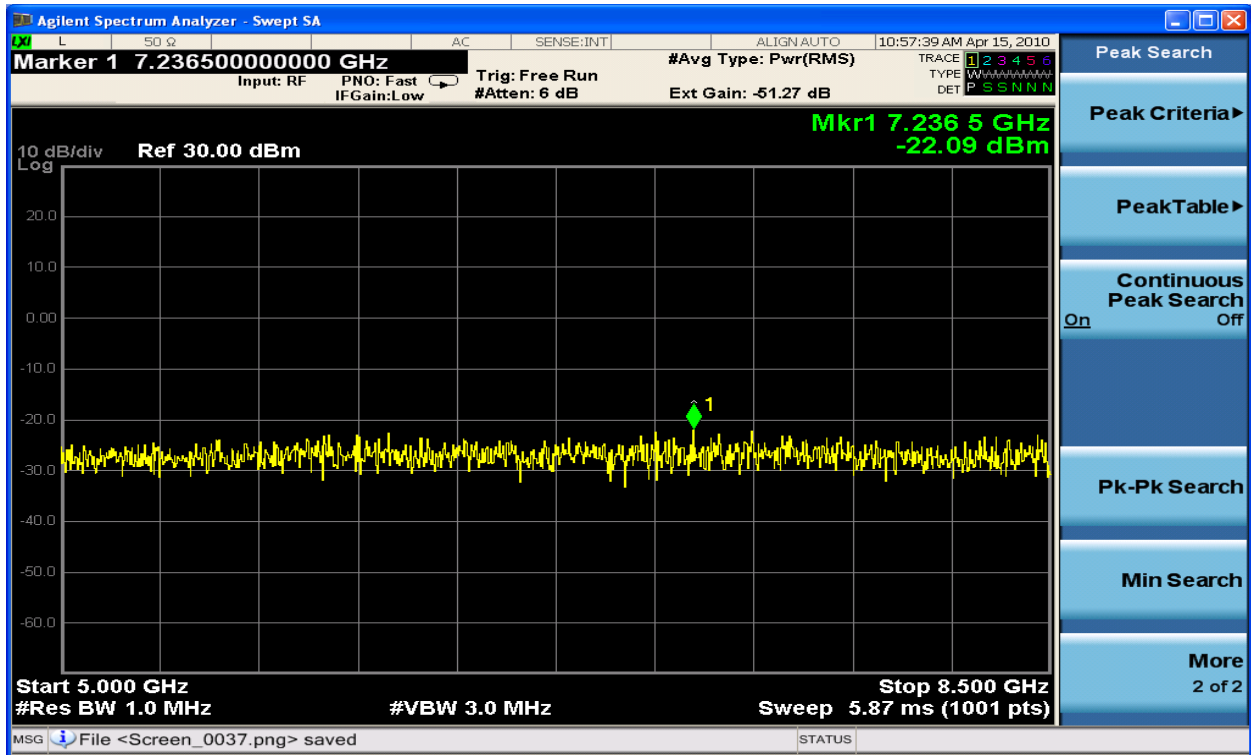

Figure 6-233 Spurious Emission TX2 QPSK 731.5MHz – 5MHz (5GHz - 8GHz)

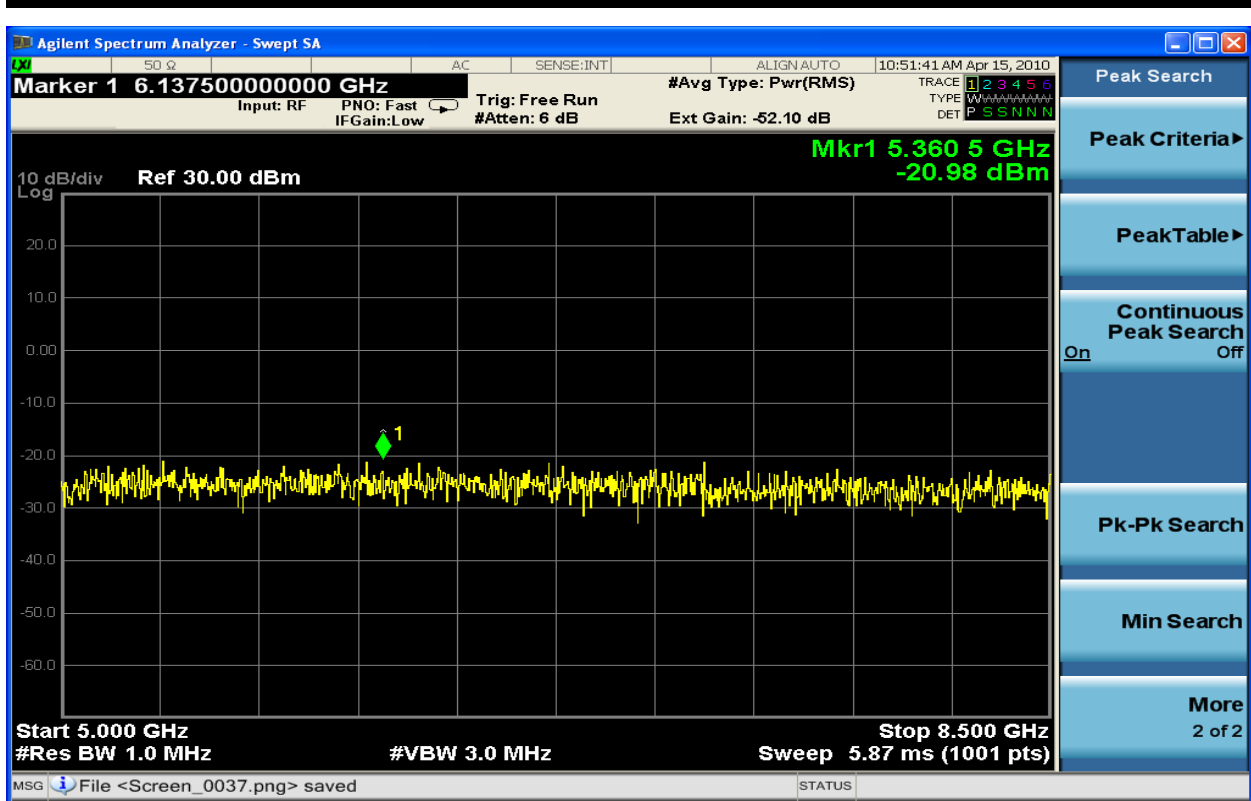

Figure 6-234 Spurious Emission TX1 16QAM 731.5MHz – 5MHz (5GHz - 8GHz)

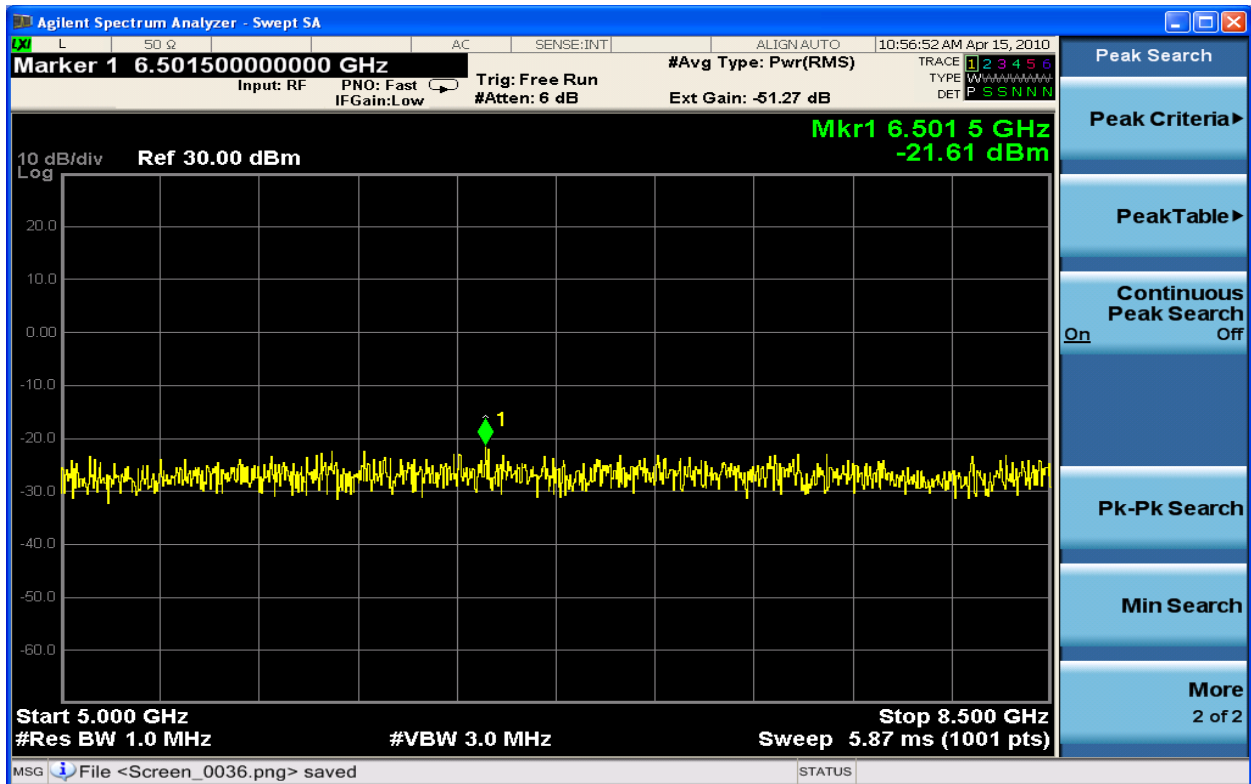

Figure 6-235 Spurious Emission TX2 16QAM 731.5MHz – 5MHz (5GHz - 8GHz)

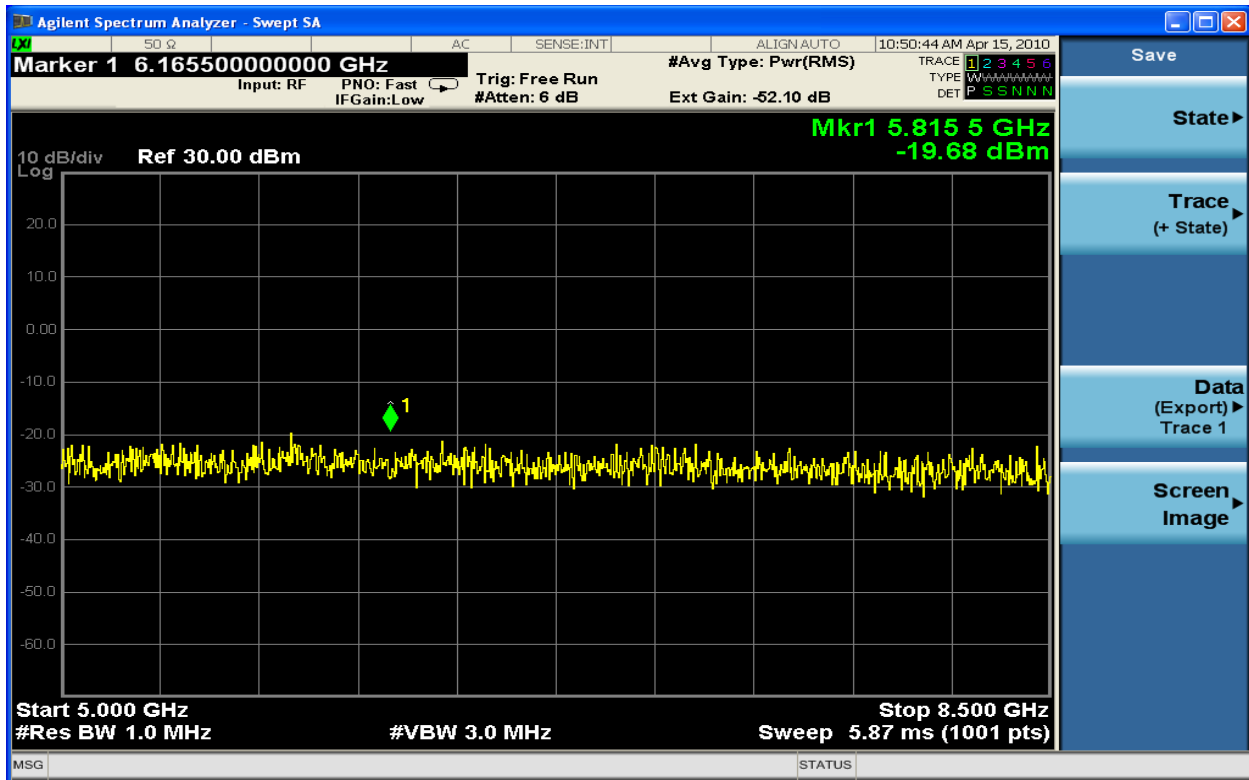

Figure 6-236 Spurious Emission TX1 64QAM 731.5MHz – 5MHz (5GHz - 8GHz)

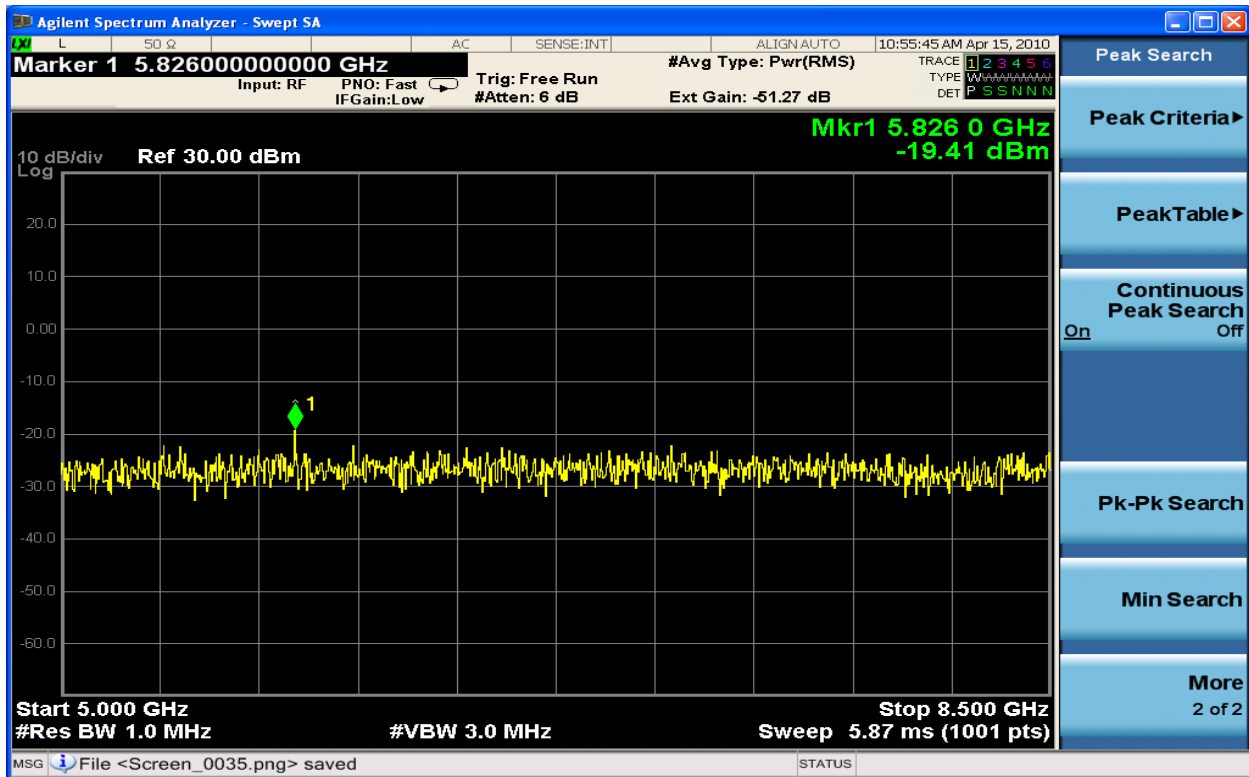

Figure 6-237 Spurious Emission TX2 64QAM 731.5MHz – 5MHz (5GHz - 8GHz)

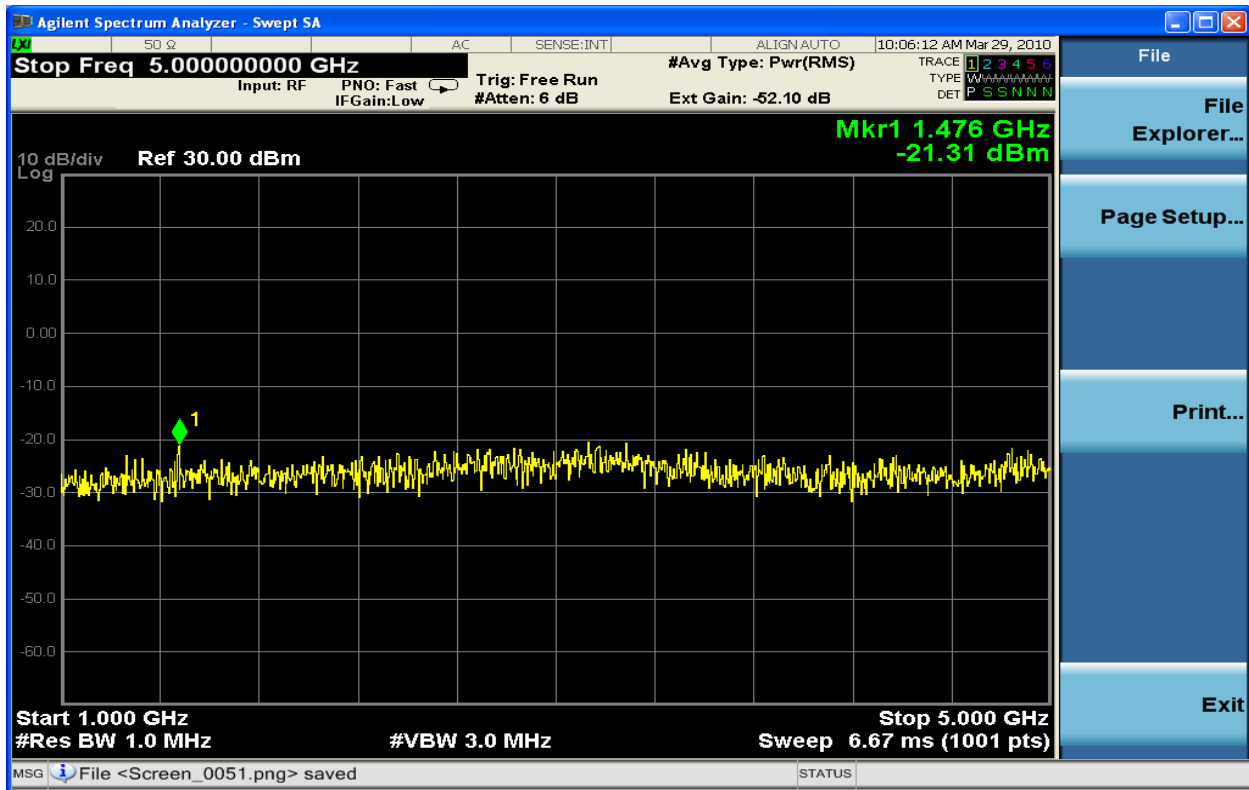

Figure 6-238 Spurious Emission TX1 QPSK 737MHz – 5MHz (1GHz - 5GHz)

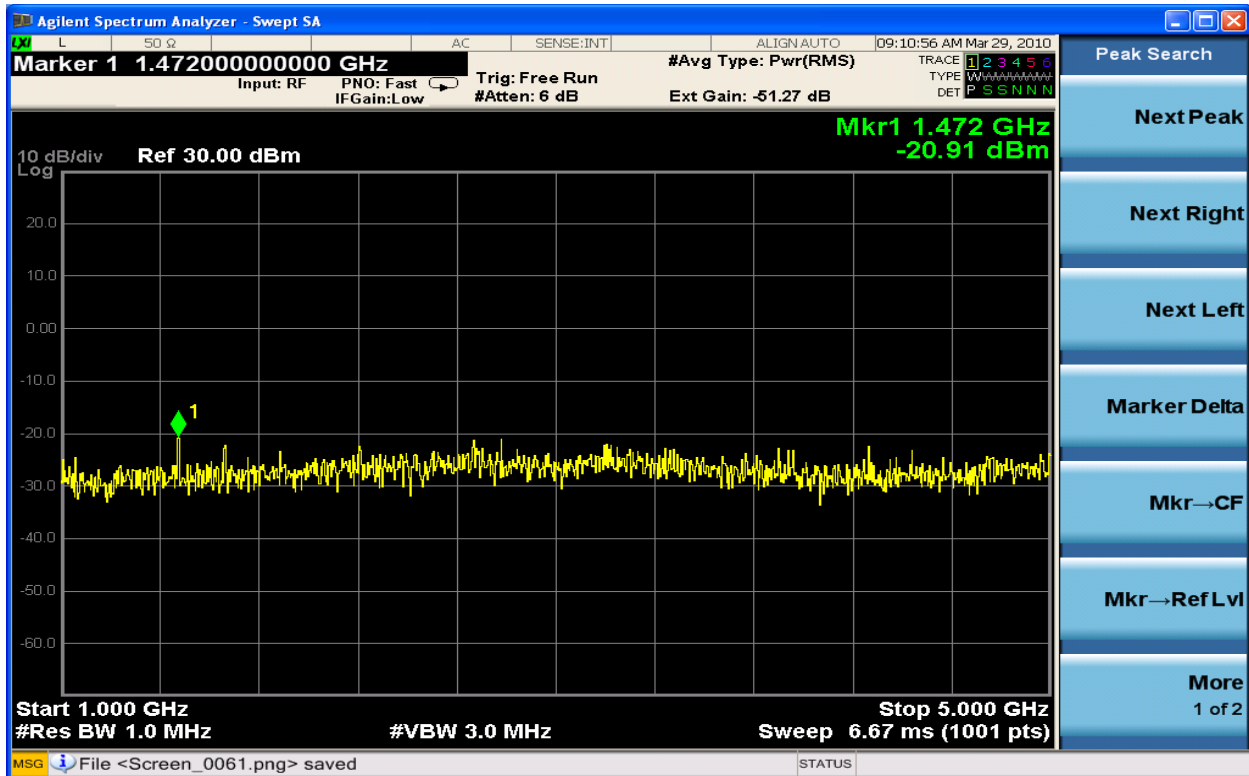

Figure 6-239 Spurious Emission TX2 QPSK 737MHz – 5MHz (1GHz - 5GHz)



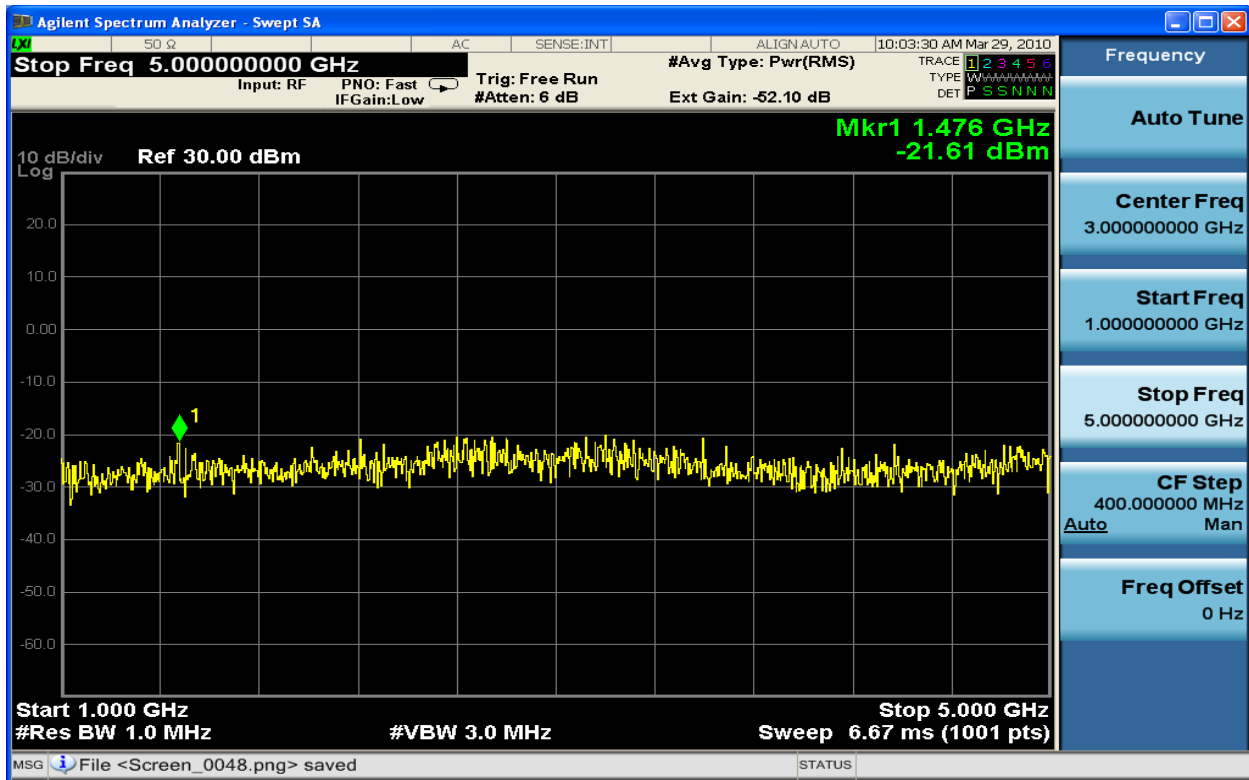

Figure 6-240 Spurious Emission TX1 16QAM 737MHz – 5MHz (1GHz - 5GHz)

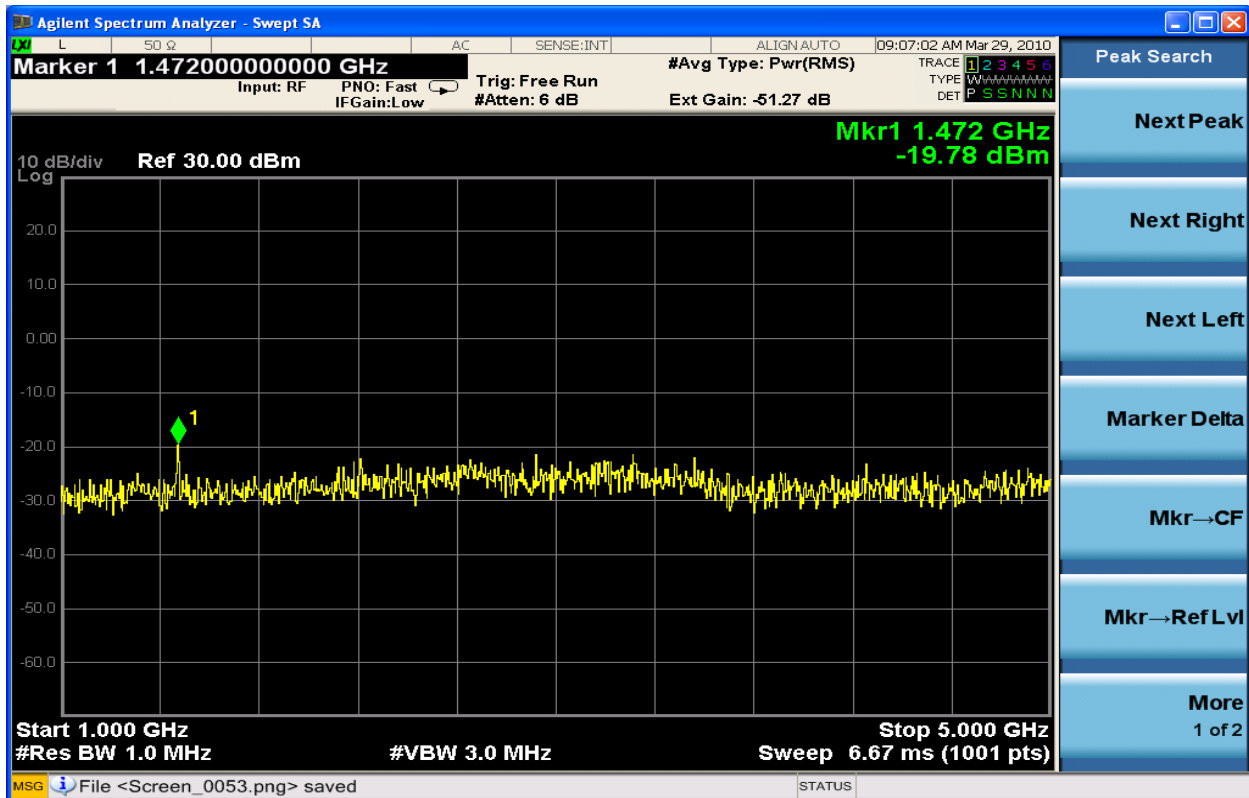

Figure 6-241 Spurious Emission TX2 16QAM 737MHz – 5MHz (1GHz - 5GHz)

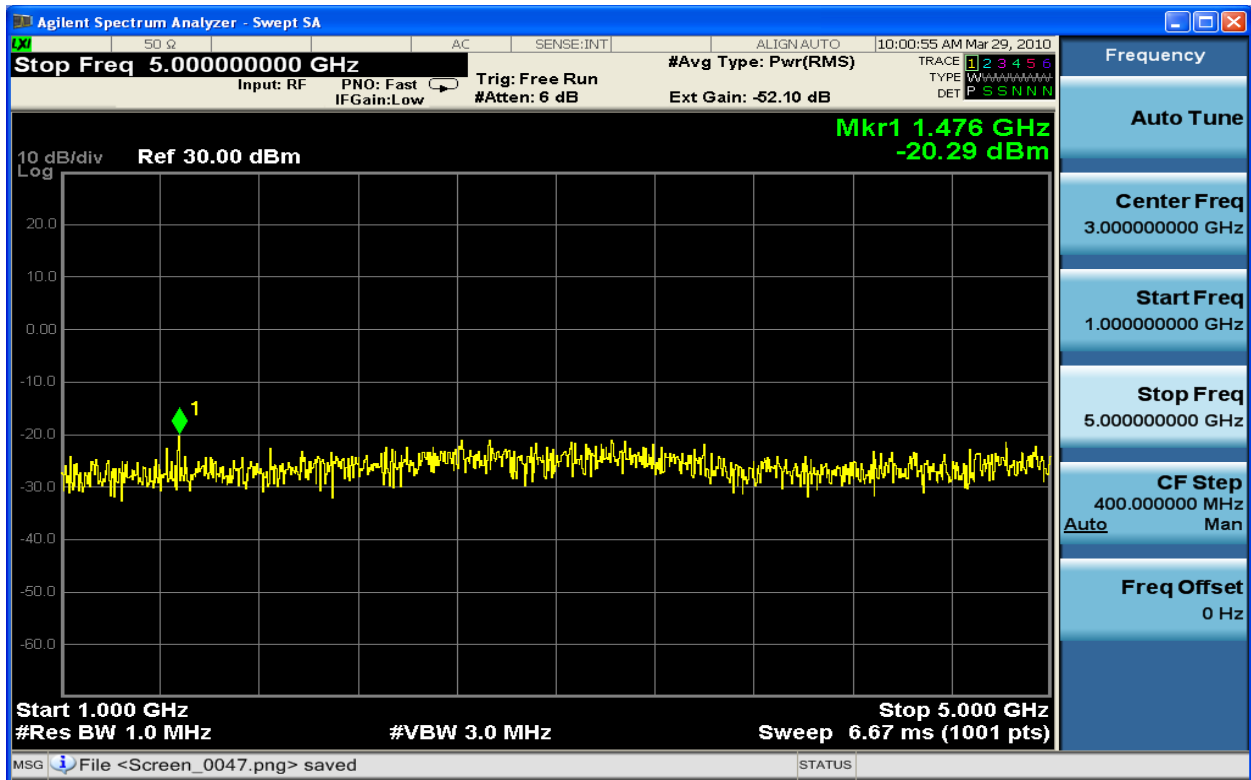

Figure 6-242 Spurious Emission TX1 64QAM 737MHz – 5MHz (1GHz - 5GHz)

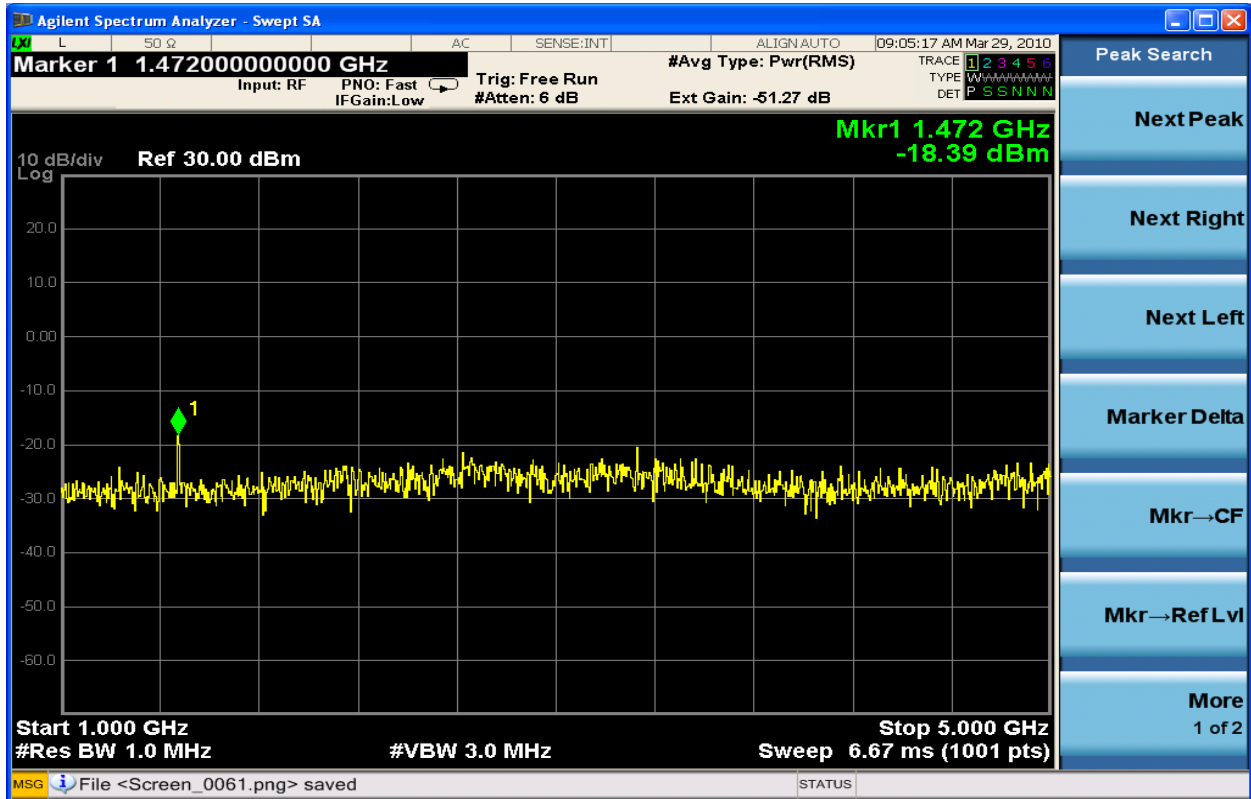

Figure 6-243 Spurious Emission TX2 64QAM 737MHz – 5MHz (1GHz - 5GHz)

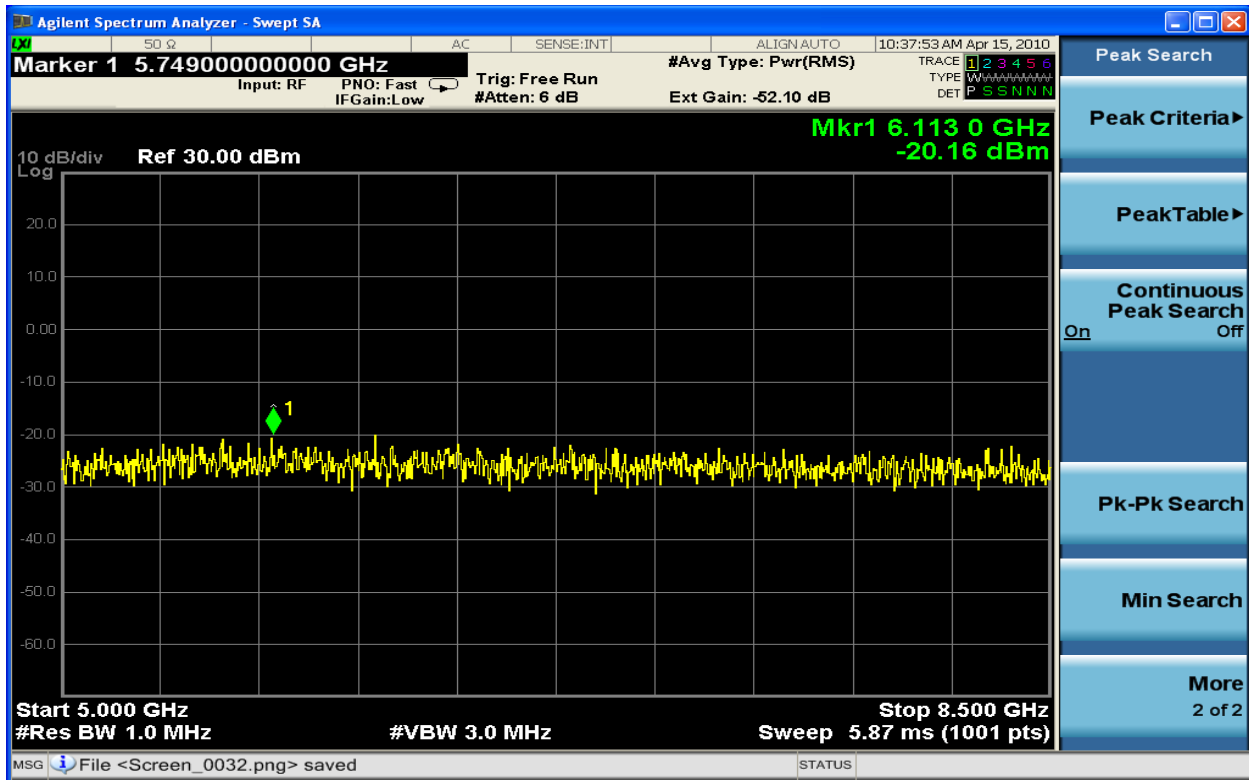

Figure 6-244 Spurious Emission TX1 QPSK 737MHz – 5MHz (5GHz - 8GHz)

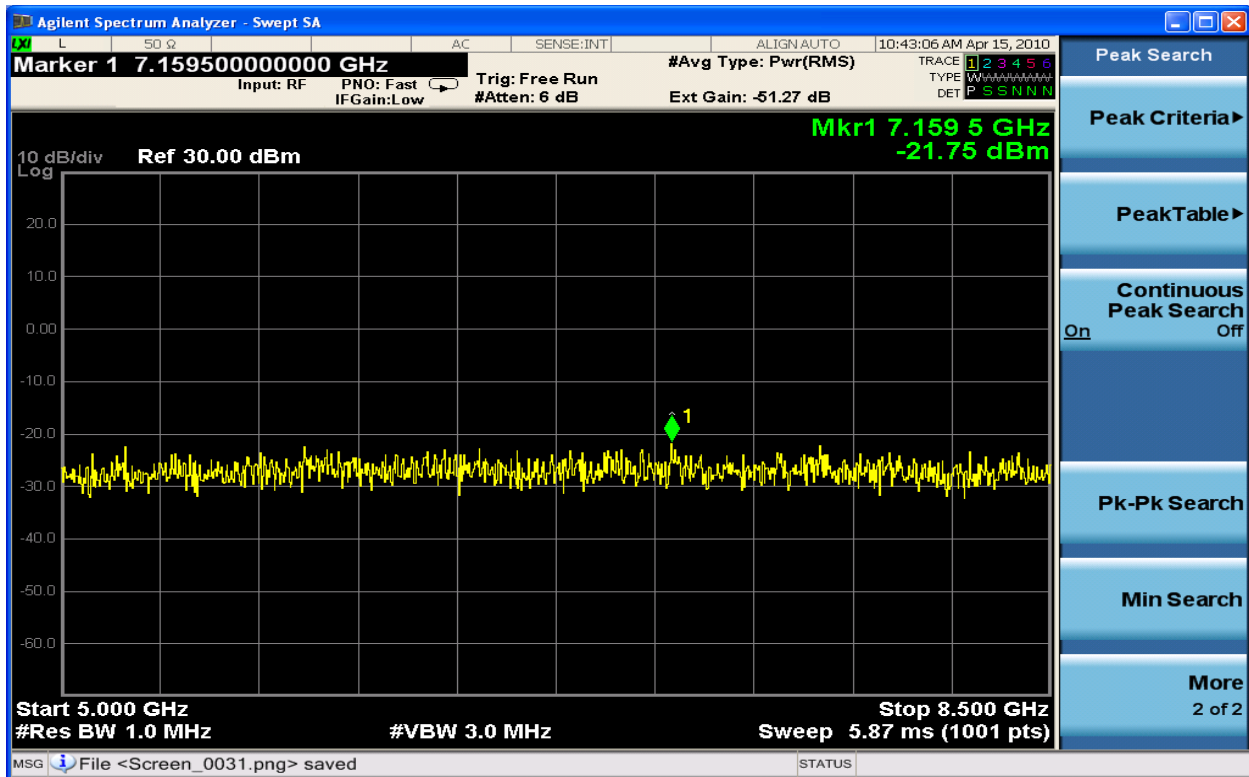

Figure 6-245 Spurious Emission TX2 QPSK 737MHz – 5MHz (5GHz - 8GHz)

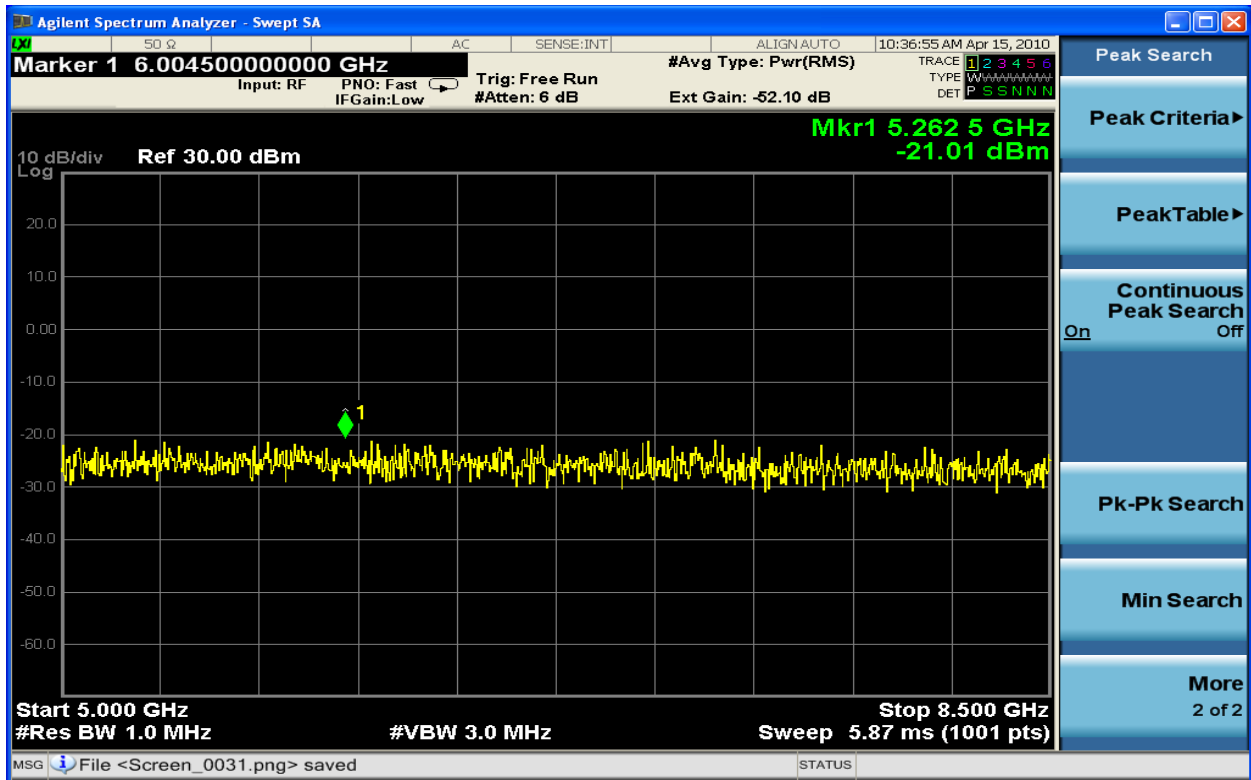

Figure 6-246 Spurious Emission TX1 16QAM 737MHz – 5MHz (5GHz - 8GHz)

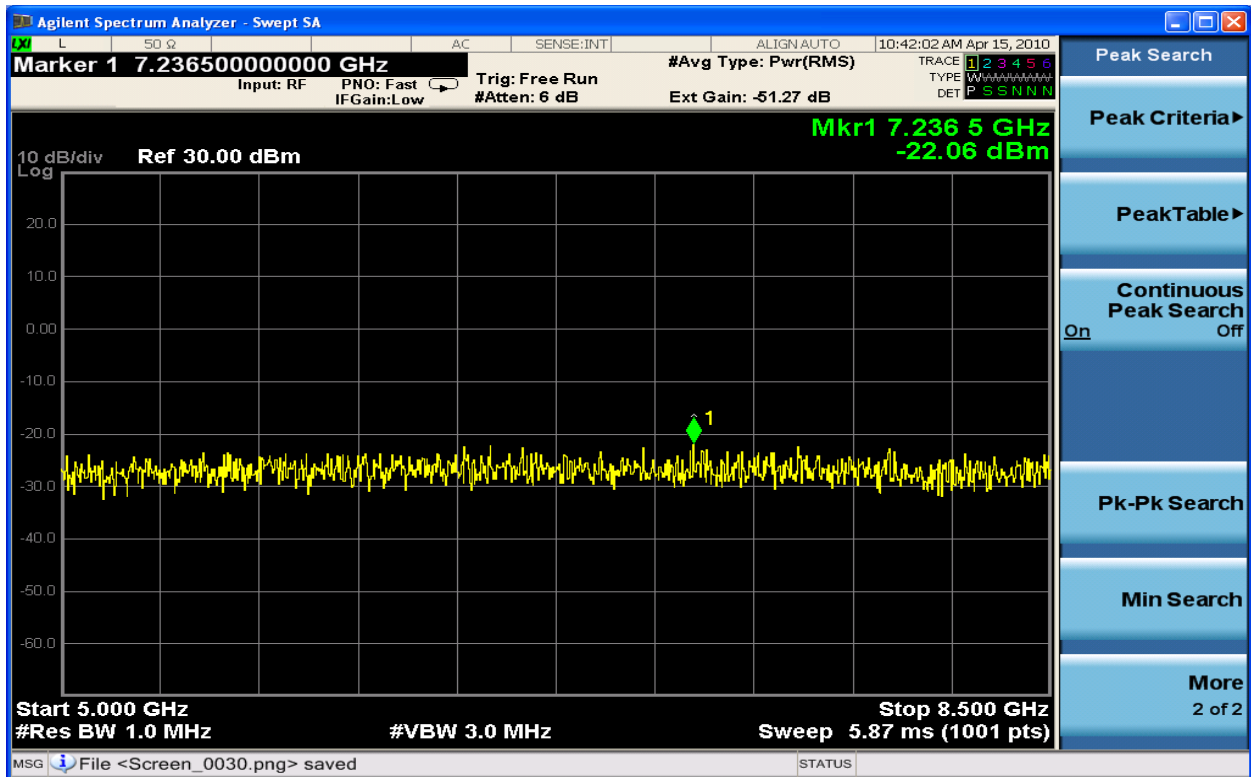

Figure 6-247 Spurious Emission TX2 16QAM 737MHz – 5MHz (5GHz - 8GHz)

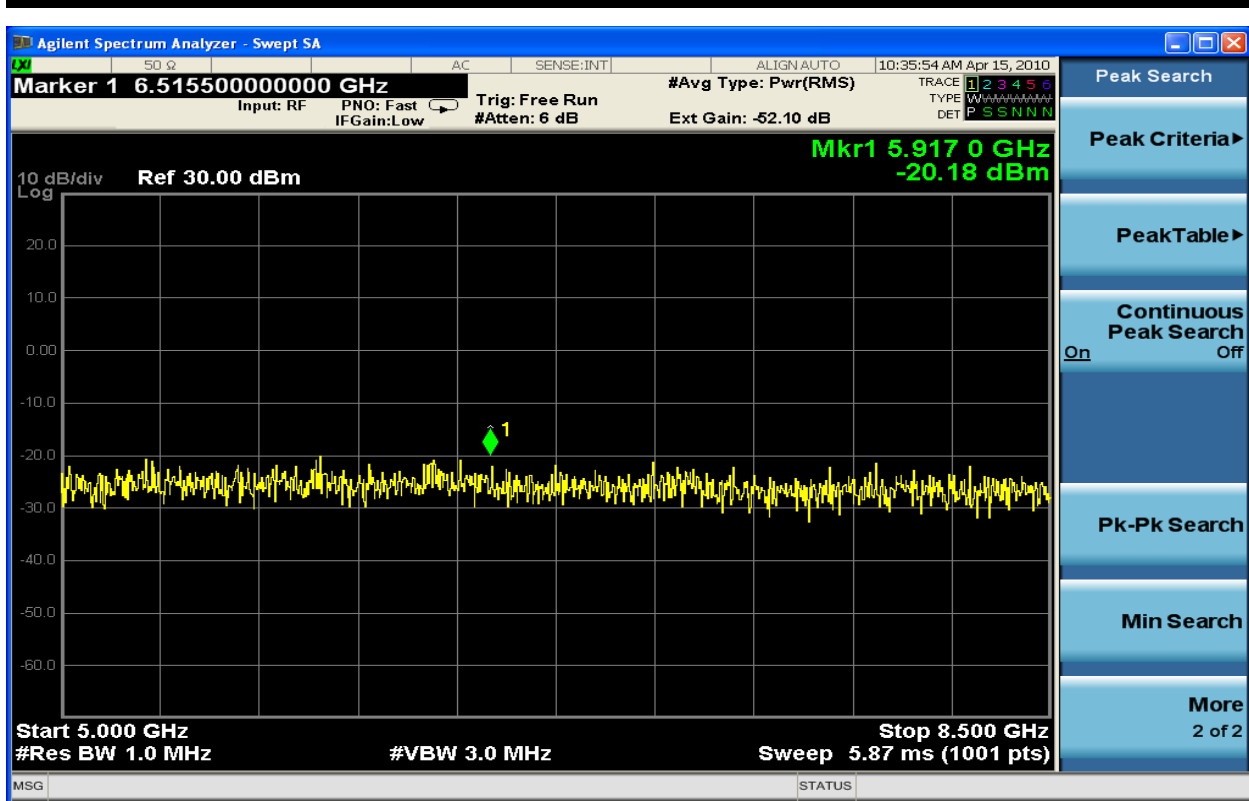

Figure 6-248 Spurious Emission TX1 64QAM 737MHz – 5MHz (5GHz - 8GHz)

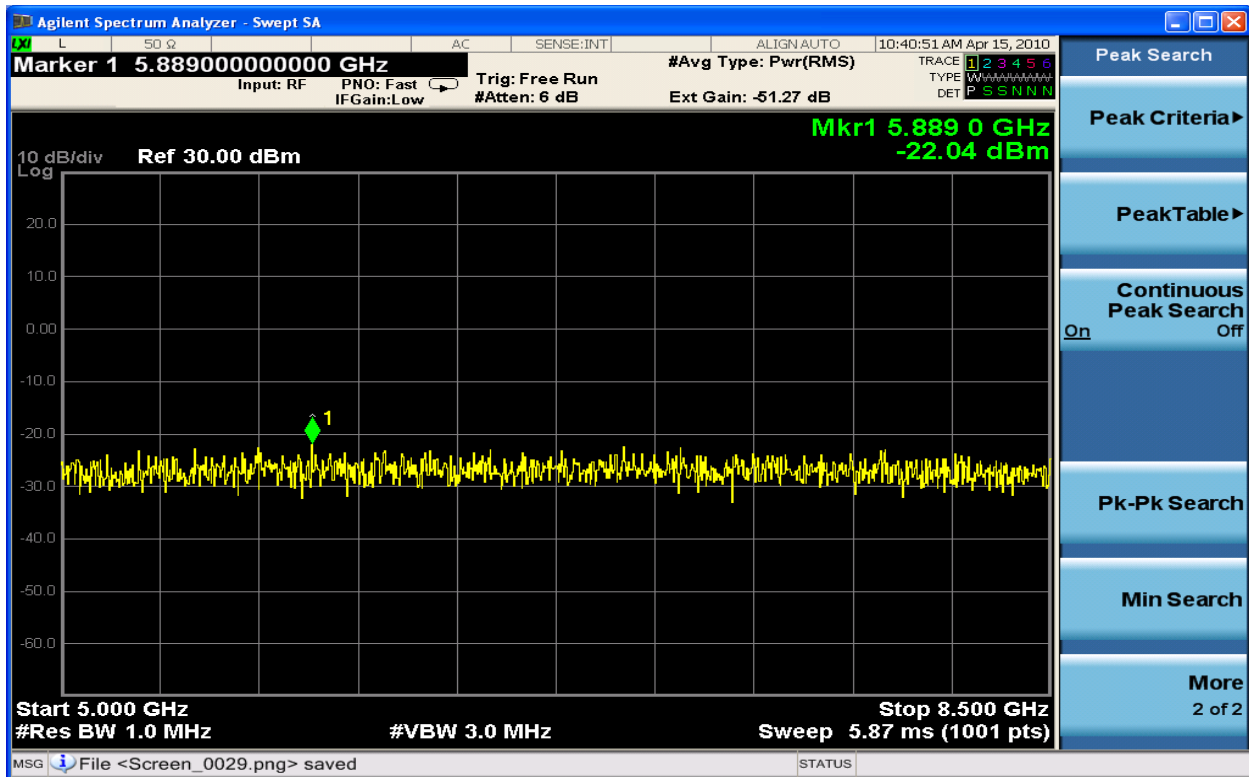

Figure 6-249 Spurious Emission TX2 64QAM 737MHz – 5MHz (5GHz - 8GHz)

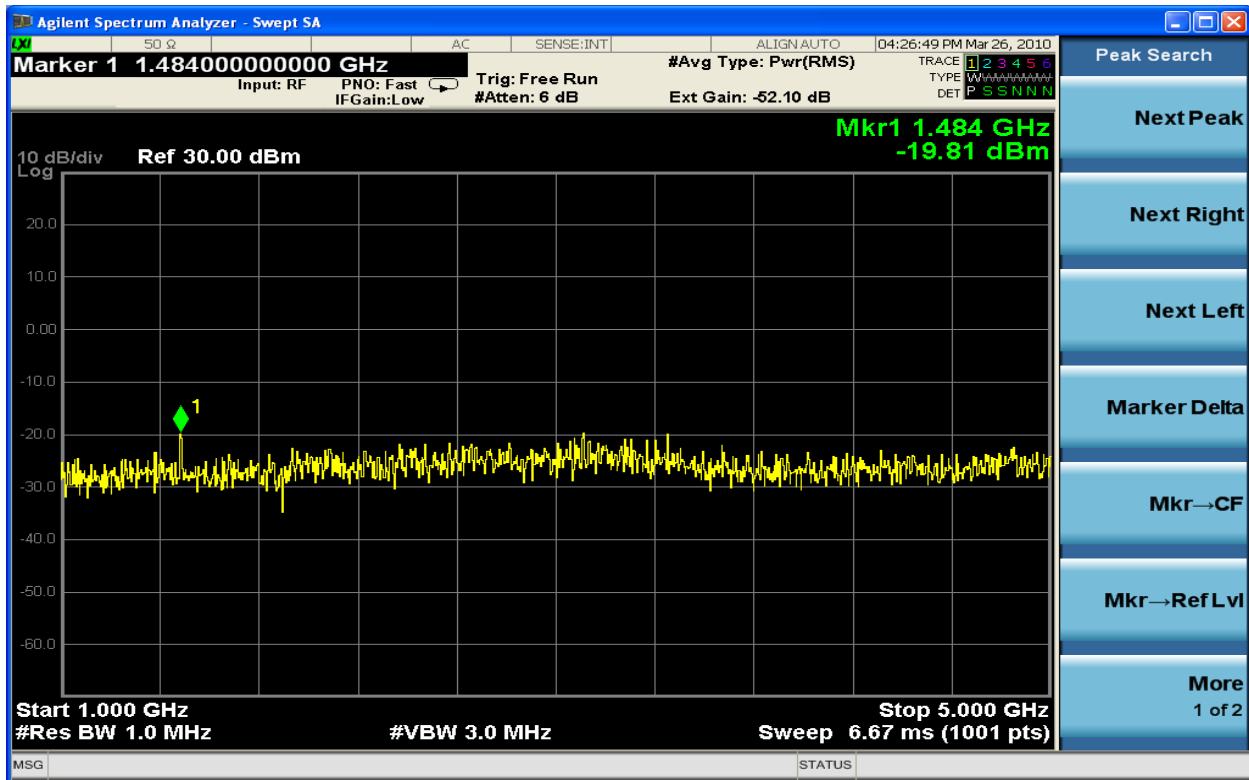

Figure 6-250 Spurious Emission TX1 QPSK 742.5MHz – 5MHz (1GHz - 5GHz)

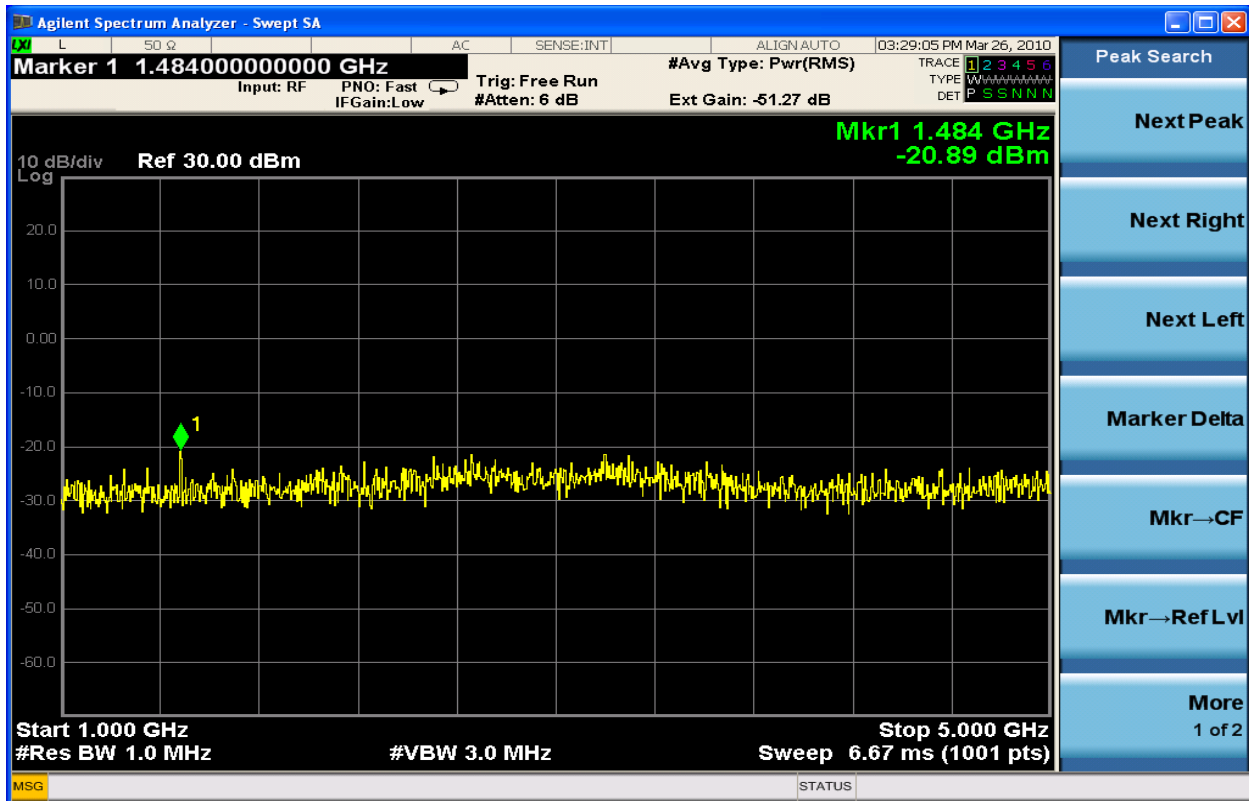

Figure 6-251 Spurious Emission TX2 QPSK 742.5MHz – 5MHz (1GHz - 5GHz)

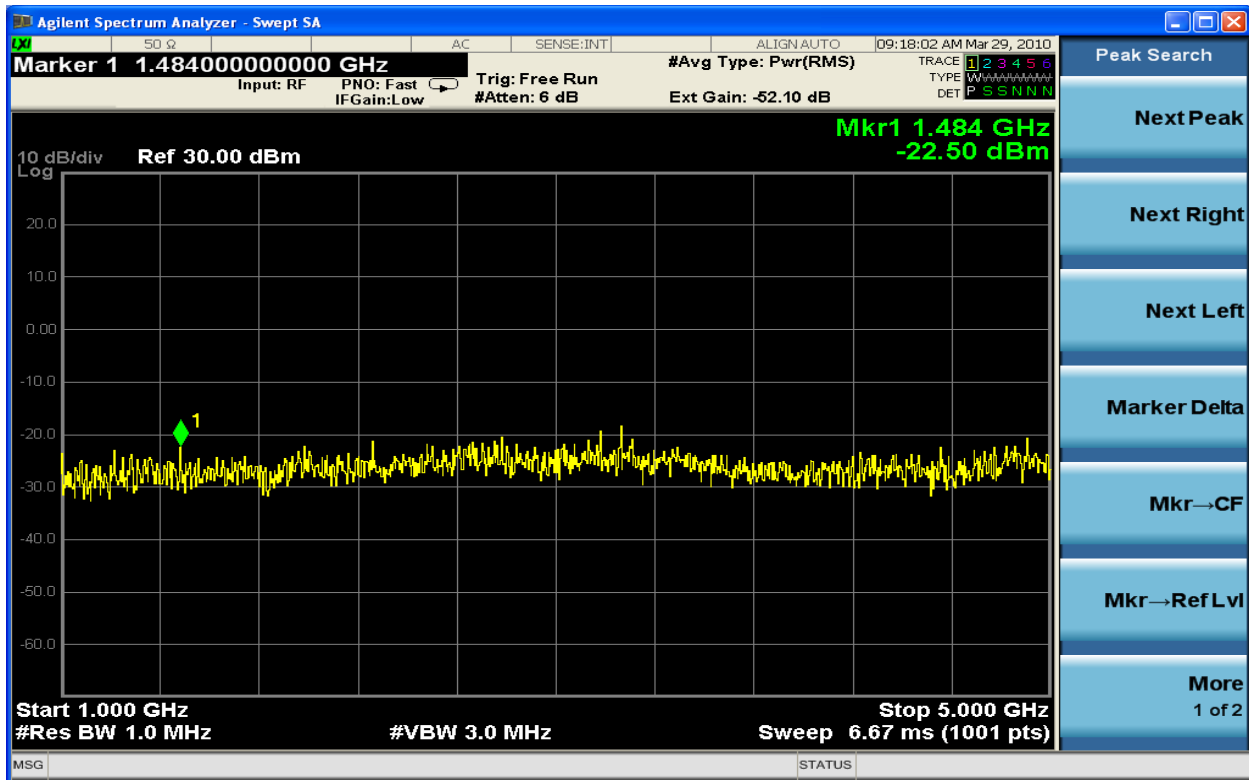

Figure 6-252 Spurious Emission TX1 16QAM 742.5MHz – 5MHz (1GHz - 5GHz)

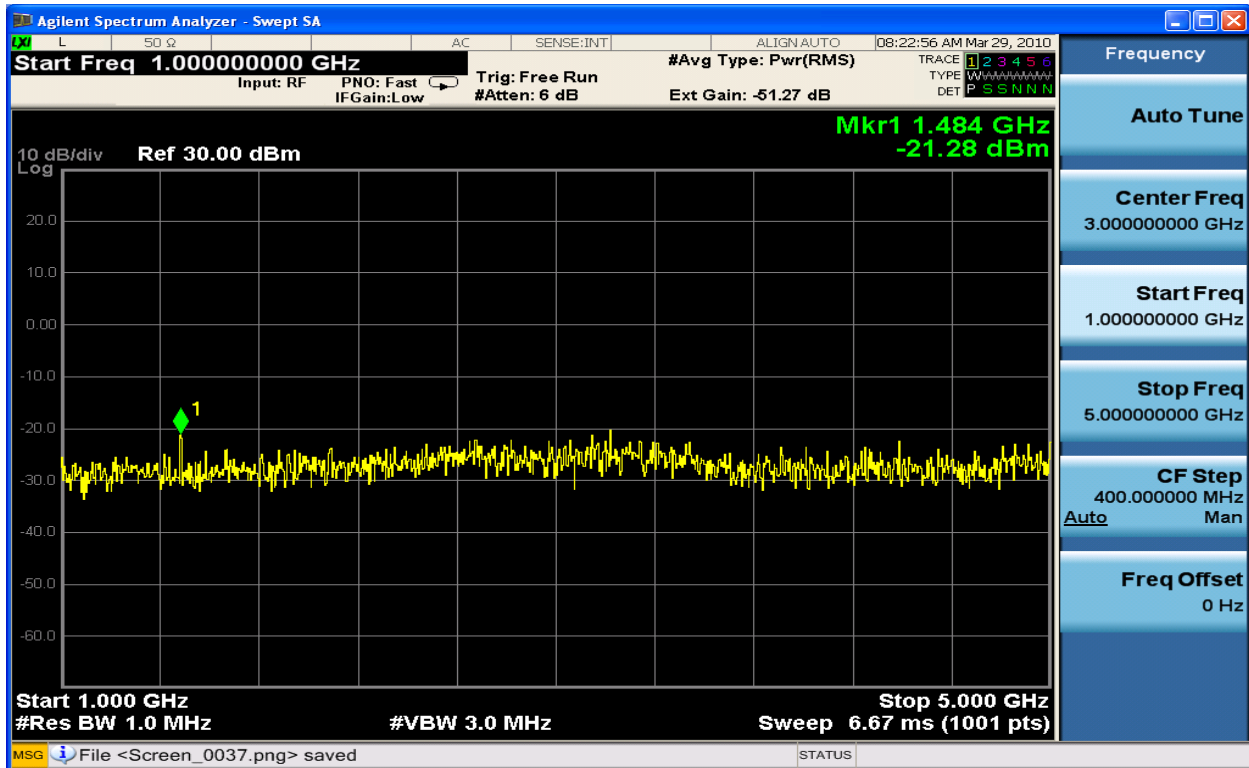

Figure 6-253 Spurious Emission TX2 16QAM 742.5MHz – 5MHz (1GHz - 5GHz)

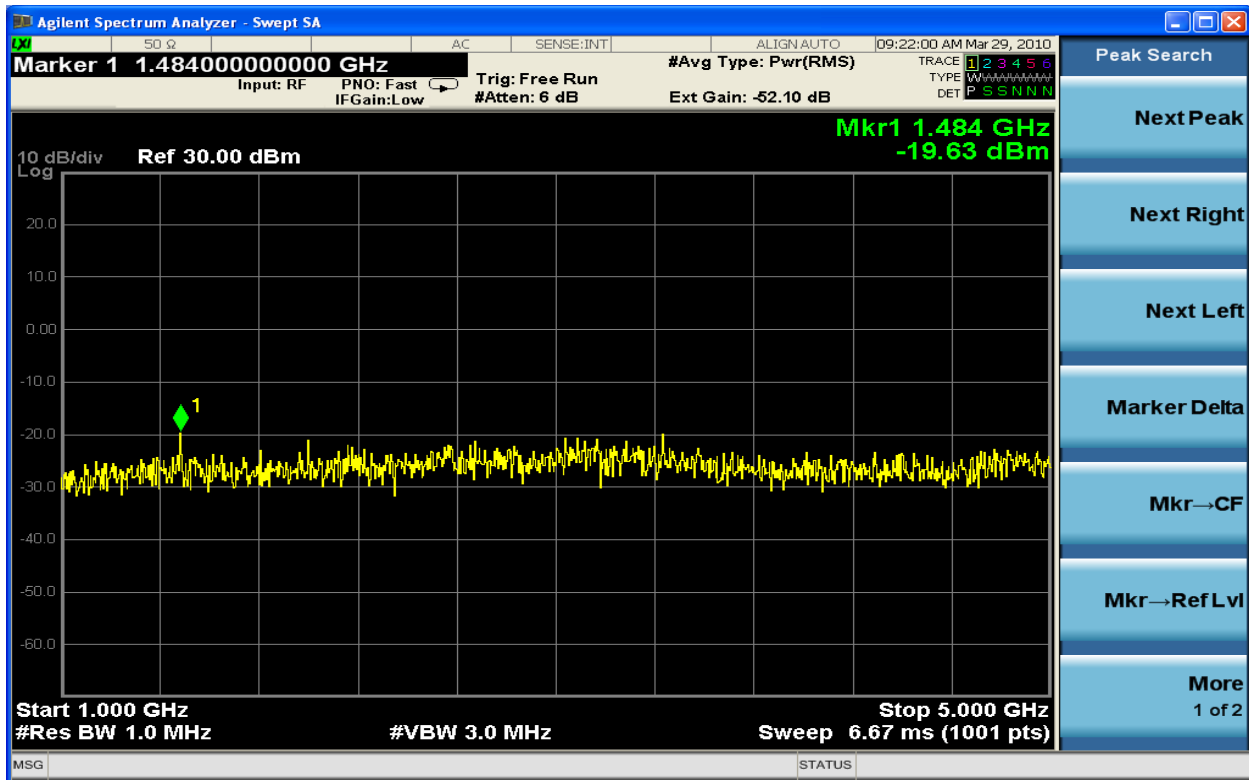

Figure 6-254 Spurious Emission TX1 64QAM 742.5MHz – 5MHz (1GHz - 5GHz)

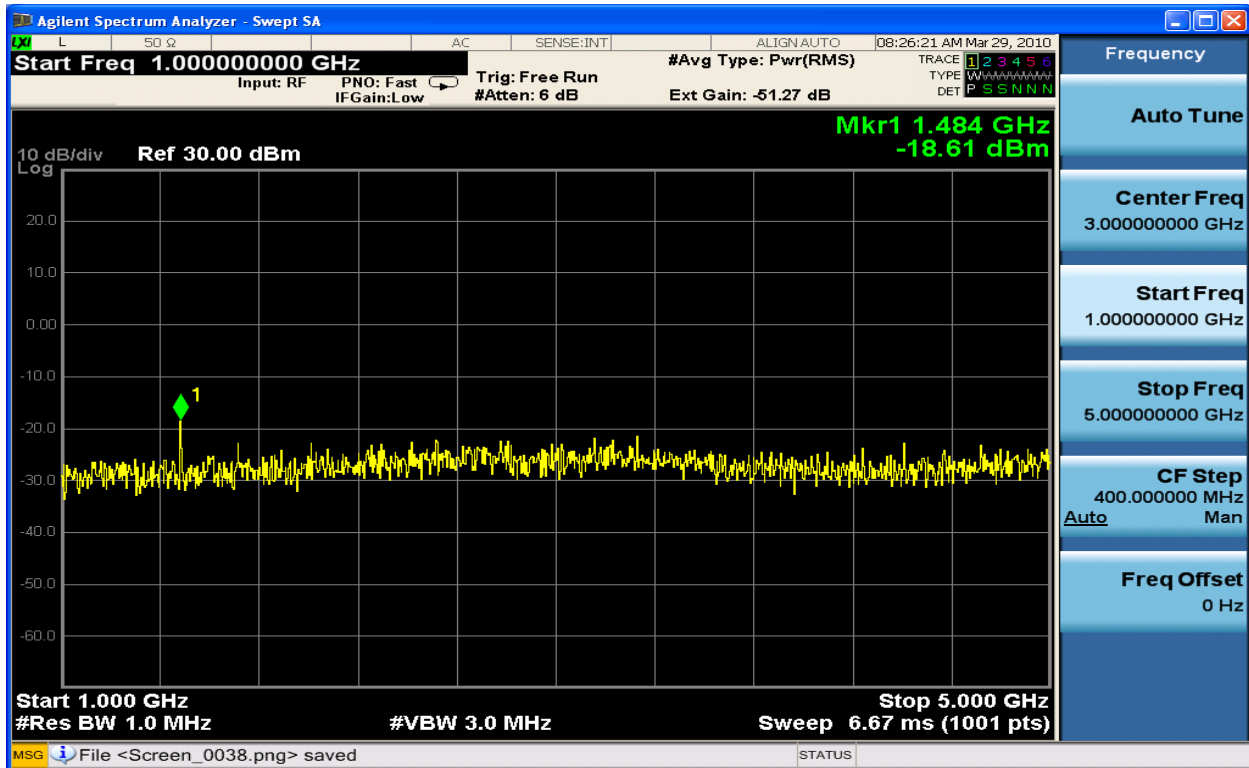

Figure 6-255 Spurious Emission TX2 64QAM 742.5MHz – 5MHz (1GHz - 5GHz)



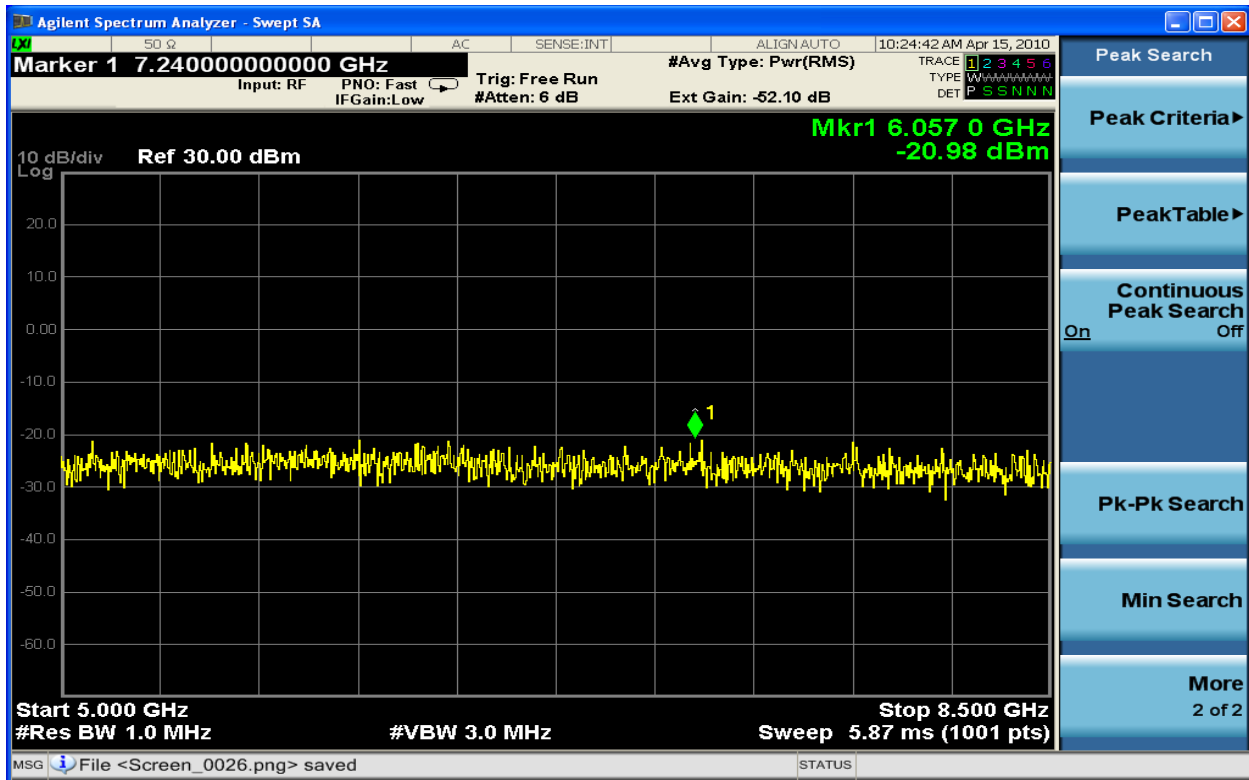

Figure 6-256 Spurious Emission TX1 QPSK 742.5MHz – 5MHz (5GHz - 8GHz)

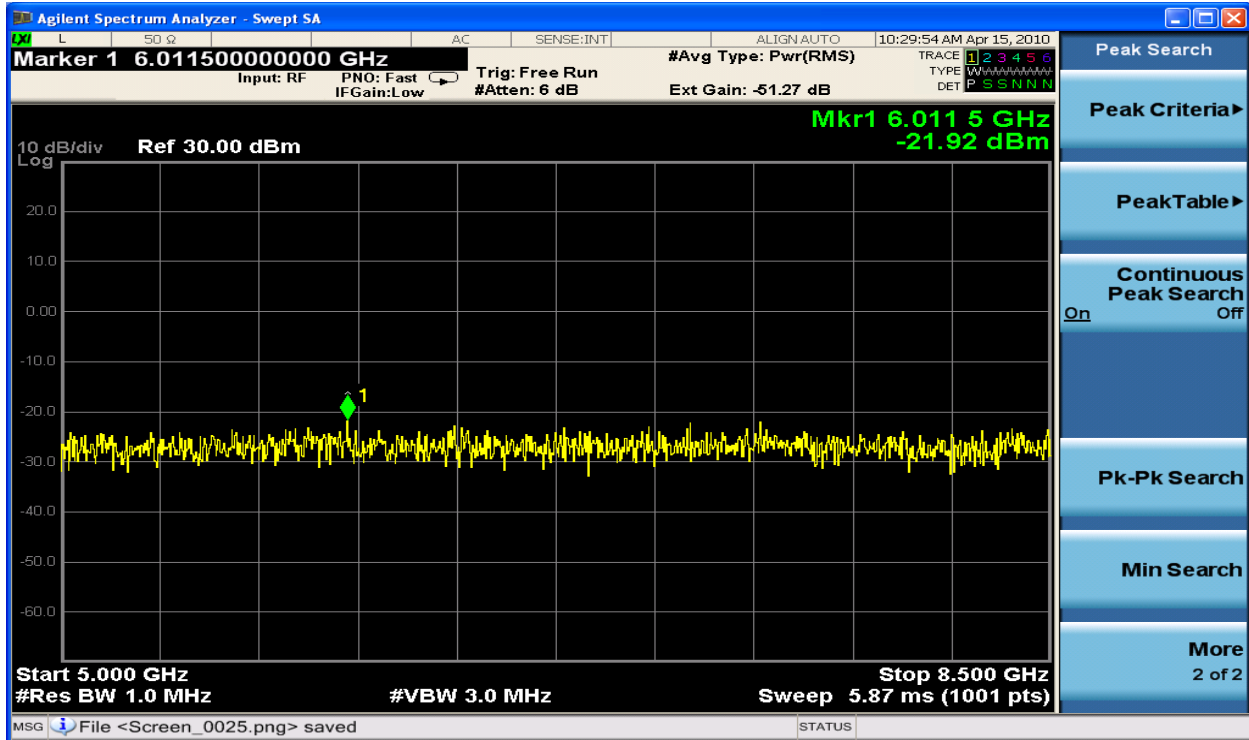

Figure 6-257 Spurious Emission TX2 QPSK 742.5MHz – 5MHz (5GHz - 8GHz)

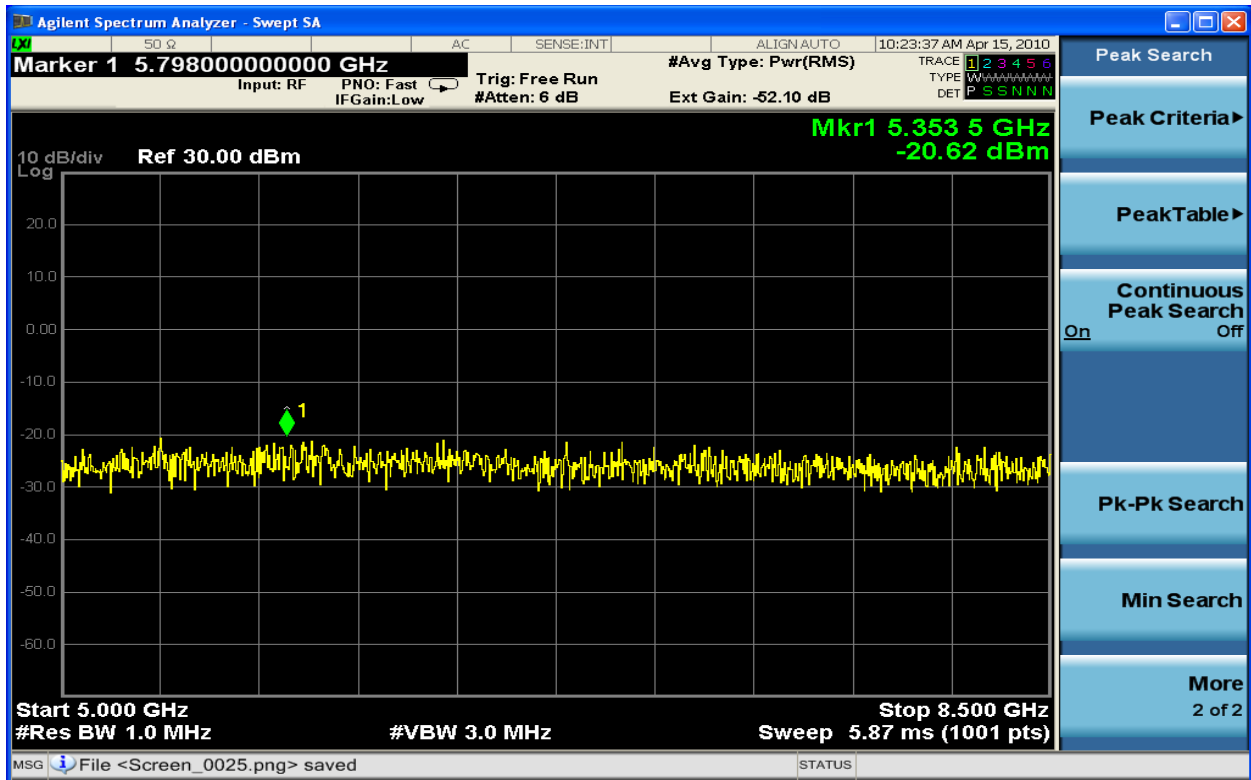

Figure 6-258 Spurious Emission TX1 16QAM 742.5MHz – 5MHz (5GHz - 8GHz)

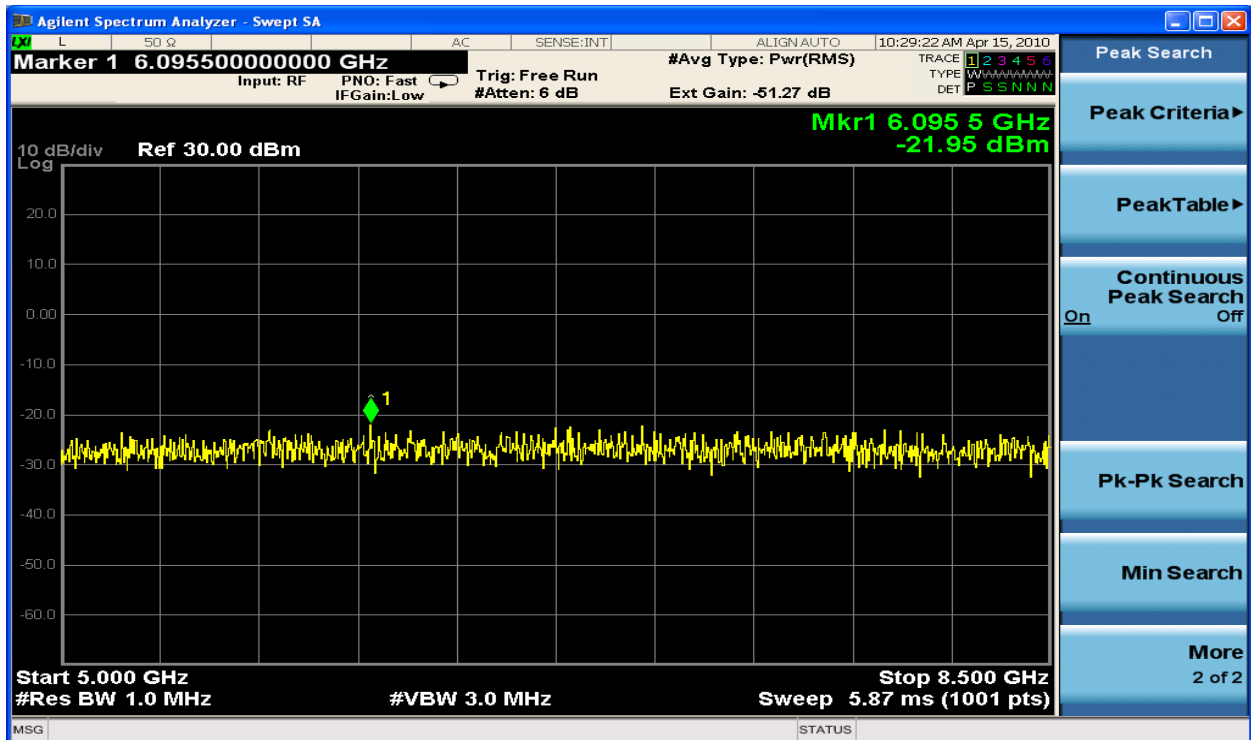

Figure 6-259 Spurious Emission TX2 16QAM 742.5MHz – 5MHz (5GHz - 8GHz)