

ROGERS LABS, INC.

4405 West 259th Terrace
Louisburg, KS 66053
Phone / Fax (913) 837-3214

Class 2 Permissive Change Test Report

47CFR Part 87, and RSS-141

Model: TY92

Aviation Communications Transceiver

118-136.975 MHz

FCC ID: VZI00879

IC: 10614A-00879

Trig Avionics Limited

Heriot Watt Research Park, Riccarton
Currie EH14 4AP United Kingdom

FCC Designation: US5305

ISED Registration: 3041A-1

Test Report Number: 211122

Test Date: November 22, 2021

Certifying Engineer: *Scot D. Rogers*

Scot D. Rogers
Rogers Labs, Inc.
4405 West 259th Terrace
Louisburg, KS 66053
Telephone/Facsimile: (913) 837-3214

This report shall not be reproduced except in full, without the written approval of the laboratory. This report must not be used by the client to claim product certification, approval, or endorsement by NVLAP, NIST, or any agency of the U.S. Government.

Rogers Labs, Inc.

4405 West 259th Terrace

Louisburg, KS 66053

Phone/Fax: (913) 837-3214

Revision 1

Trig Avionics Limited

Model: TY92

Test: 211122

Test to: 47CFR 2, 87, and RSS-141

File: Trig VZI00879 VHF Com C2PC TstRpt 211122 r1

SN: 003

FCC ID: VZI00879

IC: 10614A-00879

Date: December 17, 2021

Page 1 of 28

Table of Contents

| | |
|--------------------------------------------------------------------------------|----|
| TABLE OF CONTENTS..... | 2 |
| REVISION HISTORY | 3 |
| EXECUTIVE SUMMARY | 4 |
| SUMMARY..... | 4 |
| ATTESTATIONS..... | 4 |
| APPLICABLE STANDARDS & TEST PROCEDURES | 5 |
| OPINION / INTERPRETATION OF RESULTS | 5 |
| APPLICATION FOR CERTIFICATION..... | 5 |
| <i>EQUIPMENT UNDER TEST</i> | 8 |
| System Description | 8 |
| Equipment Configuration | 9 |
| UNITS OF MEASUREMENTS | 9 |
| TEST SITE LOCATIONS | 9 |
| ENVIRONMENTAL CONDITIONS..... | 9 |
| TRANSMITTER POWER OUTPUT | 10 |
| Measurements Required | 10 |
| Test Arrangement..... | 10 |
| Table 1 Transmitter Power Results..... | 11 |
| Figure 1 Power Output Across Frequency Band 118-136.750 MHz (25 kHz mode)..... | 12 |
| Figure 2 Power Output Across Frequency Band 118-136.750 MHz (8.33 kHz) | 13 |
| OCCUPIED BANDWIDTH | 14 |
| Measurements Required | 14 |
| Test Arrangement..... | 14 |

| | |
|----------------------------------------------------------------------------|-----------|
| Table 2 Occupied Bandwidth Results | 15 |
| Figure 3 Occupied Band Width (25 kHz channels 118.000-136.975 MHz) | 16 |
| Figure 4 Occupied Band Width (8.33 kHz channels 118.000-136.992 MHz) | 17 |
| SPURIOUS EMISSIONS AT ANTENNA TERMINALS..... | 18 |
| Measurements Required | 18 |
| Test Arrangement..... | 18 |
| Table 3 Spurious Emissions at Antenna Terminal Results | 19 |
| Figure 5 Spurious Emissions at Antenna Terminal | 20 |
| Figure 6 Spurious Emissions at Antenna Terminal | 21 |
| Figure 7 Spectral Emission Mask at Antenna Terminal | 22 |
| ANNEX..... | 23 |
| Annex A Measurement Uncertainty Calculations | 24 |
| Annex B Test Equipment List..... | 25 |
| Annex C Rogers Qualifications..... | 27 |
| Annex D Laboratory Certificate of Accreditation | 28 |

Revision History

Revision 1 Issued December 17, 2021

Executive Summary

In accordance with the Federal Communications, Code of Federal Regulations dated December 6, 2021, Part 2 Subpart J, Paragraphs 2.932, 2.10431, Part 87, Subchapter D, and Industry Canada RSS-141 Issue 2, June 2010 the following information is submitted for consideration in processing Class 2 Permissible Change. The equipment remains electrically identical to original equipment authorization. The change is result of obsolescent components and replacement parts for circuit design.

Summary

- The device fulfills the general approval requirements of the referenced standards identified in this test report and requested by the customer.

Name of Applicant: Trig Avionics Limited
Heriot Watt Research Park, Riccarton
Currie EH14 4AP United Kingdom
HVIN: TY92

FCC ID: VZI00879 IC: 10614A-00879

Frequency of Operation: 118-136.975 MHz

18.6 watts, occupied bandwidth 6,000 kHz

Attestations

This equipment has been tested in accordance with the standards identified in this report and determined in compliance with the referenced requirements and regulations. To the best of my knowledge all testing was performed using the measurement procedures identified in this report. All instrumentation used during compliance testing are calibrated and remain in a calibrated state in accordance with ISO 17025:2017 requirements. Further, I attest that all necessary measurements were completed at Rogers Labs, Inc.

Rogers Labs, Inc.
4405 West 259th Terrace
Louisburg, KS 66053

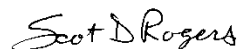

Scot D. Rogers
Date: November 22, 2021

| | | |
|---------------------------|---------------------------------------------------|-------------------------|
| Rogers Labs, Inc. | Trig Avionics Limited | SN: 003 |
| 4405 West 259th Terrace | Model: TY92 | FCC ID: VZI00879 |
| Louisburg, KS 66053 | Test: 211122 | IC: 10614A-00879 |
| Phone/Fax: (913) 837-3214 | Test to: 47CFR 2, 87, and RSS-141 | Date: December 17, 2021 |
| Revision 1 | File: Trig VZI00879 VHF Com C2PC TstRpt 211122 r1 | Page 4 of 28 |

Applicable Standards & Test Procedures

In accordance with the Federal Communications Code Part 2, Subpart J, Paragraphs 2.932, 2.1043, paragraphs of Part 87, and RSS-141 Issue 2 the following information is submitted for consideration in processing Class 2 Permissible Change. Test procedures used are the established Methods of Measurement of Radio-Noise Emissions as described in ANSI C63.4-2014 and ANSI C63.26-2015.

Opinion / Interpretation of Results

| Tests Performed | Results |
|--------------------------------------------------------------------|----------|
| Emissions Tests | |
| Requirements per CFR47 paragraphs 87.131 and RSS-141 paragraph 5.1 | Complies |
| Requirements per CFR47 paragraphs 87.135 and RSS-141 paragraph 5.1 | Complies |
| Requirements per CFR47 paragraphs 87.139 and RSS-141 paragraph 5.2 | Complies |

Application for Certification

(1) The full name and mailing address of the manufacturer of the device and the applicant for certification.

Trig Avionics Limited
Heriot Watt Research Park, Riccarton Currie EH14 4AP United Kingdom

(2) FCC identifier. FCC ID: VZI00879 IC: 10614A-00879

(3) A copy of the installation and operating instructions to be furnished the user. A draft copy of the instructions may be submitted if the actual document is not available. The actual document shall be furnished to the FCC when it becomes available.

Refer to original application for Instruction Manual.

(4) Type or types of emission. 6K00A3E (25 kHz), (5K60A3E for 8.33 kHz operation)

(5) Frequency range. 118-136.975 MHz (25 kHz channel operation), (118-136.992, 8.33 kHz channels)

(6) Range of operating power values or specific operating power levels, and description of any means provided for variation of operating power.

| | | |
|---------------------------|---------------------------------------------------|-------------------------|
| Rogers Labs, Inc. | Trig Avionics Limited | SN: 003 |
| 4405 West 259th Terrace | Model: TY92 | FCC ID: VZI00879 |
| Louisburg, KS 66053 | Test: 211122 | IC: 10614A-00879 |
| Phone/Fax: (913) 837-3214 | Test to: 47CFR 2, 87, and RSS-141 | Date: December 17, 2021 |
| Revision 1 | File: Trig VZI00879 VHF Com C2PC TstRpt 211122 r1 | Page 5 of 28 |

Nominal 18.6 Watts

- (7) Maximum power rating as defined in the applicable part(s) of the rules.

Maximum allowable power output of 55 Watts as defined per CFR47 paragraph 87.131.

- (8) The dc voltages applied to and dc currents into the several elements of the final radio frequency amplifying device for normal operation over the power range.

Power delivered into final amplifier 20.0 Volts at 5.0 Amps (100 Watts)

- (9) Tune-up procedure over the power range, or at specific operating power levels.

Refer to original application for Transceiver Alignment Procedure.

- (10) A schematic diagram and a description of all circuitry and devices provided for determining and stabilizing frequency, for suppression of spurious radiation, for limiting modulation, and for limiting power.

Refer to original application for Circuit information and theory of operation.

- (11) A photograph or drawing of the equipment identification plate or label showing the information to be placed thereon.

Refer to original application Exhibit for Photograph or Drawing.

- (12) Photographs (8" × 10") of the equipment of sufficient clarity to reveal equipment construction and layout, including meters, if any, and labels for controls and meters and sufficient views of the internal construction to define component placement and chassis assembly. Insofar as these requirements are met by photographs or drawings contained in instruction manuals supplied with the certification request, additional photographs are necessary only to complete the required showing.

Refer to original application Exhibit for Components Layout and Drawings.

- (13) For equipment employing digital modulation techniques, a detailed description of the modulation system to be used, including the response characteristics (frequency, phase, and amplitude) of any filters provided, and a description of the modulating wave train, shall be submitted for the maximum rated conditions under which the equipment will be operated.

Not applicable

- (14) The data required by §2.1046 through §2.1057, inclusive, measured in accordance with the procedures set out in §2.1041.

Data required for this Class 2 Permissible Change is contained in this application

(15) The application for certification of an external radio frequency power amplifier under part 97 of this chapter need not be accompanied by the data required by paragraph (b)(14) of this section. In lieu thereof, measurements shall be submitted to show compliance with the technical specifications in subpart C of part 97 of this chapter and such information as required by §2.1060 of this part.

Does not apply to this device or application.

(16) An application for certification of an AM broadcast stereophonic exciter-generator intended for interfacing with existing certified, or formerly type accepted or notified transmitters must include measurements made on a complete stereophonic transmitter. The instruction book must include complete specifications and circuit requirements for interconnecting with existing transmitters. The instruction book must also provide a full description of the equipment and measurement procedures to monitor modulation and to verify that the combination of stereo exciter-generator and transmitter meet the emission limitations of §73.44.

Does not apply to this device or application.

(17) Applications for certification required by §25.129 of this chapter shall include any additional equipment test data required by that section.

Does not apply to this device or application.

(18) An application for certification of a software defined radio must include the information required by §2.944.

Does not apply to this device or application.

(19) Applications for certification of equipment operating under part 27 of this chapter, that a manufacturer is seeking to certify for operation in the:

(i) 1755-1780 MHz, 2155-2180 MHz, or both bands shall include a statement indicating compliance with the pairing of 1710-1780 and 2110-2180 MHz specified in §§27.5(h) and 27.75 of this chapter.

(ii) 1695-1710 MHz, 1755-1780 MHz, or both bands shall include a statement indicating compliance with §27.77 of this chapter.

(iii) 600 MHz band shall include a statement indicating compliance with §27.75 of this chapter.

Does not apply to this device or application.

(20) Before equipment operating under part 90 of this chapter and capable of operating on the 700 MHz interoperability channels (See §90.531(b)(1) of this chapter) may be

| | | |
|---------------------------|---------------------------------------------------|-------------------------|
| Rogers Labs, Inc. | Trig Avionics Limited | SN: 003 |
| 4405 West 259th Terrace | Model: TY92 | FCC ID: VZI00879 |
| Louisburg, KS 66053 | Test: 211122 | IC: 10614A-00879 |
| Phone/Fax: (913) 837-3214 | Test to: 47CFR 2, 87, and RSS-141 | Date: December 17, 2021 |
| Revision 1 | File: Trig VZI00879 VHF Com C2PC TstRpt 211122 r1 | Page 7 of 28 |

marketed or sold, the manufacturer thereof shall have a Compliance Assessment Program Supplier's Declaration of Conformity and Summary Test Report or, alternatively, a document detailing how the manufacturer determined that its equipment complies with §90.548 of this chapter and that the equipment is interoperable across vendors. Submission of a 700 MHz narrowband radio for certification will constitute a representation by the manufacturer that the radio will be shown, by testing, to be interoperable across vendors before it is marketed or sold.

Does not apply to this device or application.

- (21) Contain at least one drawing or photograph showing the test set-up for each of the required types of tests applicable to the device for which certification is requested. These drawings or photographs must show enough detail to confirm other information contained in the test report. Any photographs used must be focused originals without glare or dark spots and must clearly show the test configuration used.

Data is contained in this application or application exhibits.

Equipment Under Test

| <u>Equipment</u> | <u>Model / PN</u> | <u>Serial Number</u> |
|------------------|-------------------|----------------------|
| EUT | TY92 | 003 |

Test results in this report relate only to the items tested

Firmware Version: 1.13, Antenna is 50-ohm, Omni Directions Unity Gain

System Description

The TY92 is an aeronautical communications transceiver. The North American authorized transmitter operational frequency band is 118.000 to 136.975 MHz (operating with 25 kHz channel mode). The design Can also operate using international channels with frequency band 118.000 to 136.992 MHz (operating with 8.33 kHz channel mode). The device is marketed as Aircraft Panel Mounted Navigation Display Unit. The design provides communication capability in the Aviation VHF Band with channel operational capability for 25 kHz or 8.33 kHz Channel Spacing. In addition to the authorized frequency band the design provides for VHF operation in 8.33 kHz channel spacing for international frequency band services and compatibility. This report documents operation for this application and authorization only as provided in 47CFR 87.173 and RSS-141.

| | | |
|---------------------------|---------------------------------------------------|-------------------------|
| Rogers Labs, Inc. | Trig Avionics Limited | SN: 003 |
| 4405 West 259th Terrace | Model: TY92 | FCC ID: VZI00879 |
| Louisburg, KS 66053 | Test: 211122 | IC: 10614A-00879 |
| Phone/Fax: (913) 837-3214 | Test to: 47CFR 2, 87, and RSS-141 | Date: December 17, 2021 |
| Revision 1 | File: Trig VZI00879 VHF Com C2PC TstRpt 211122 r1 | Page 8 of 28 |

Equipment Configuration

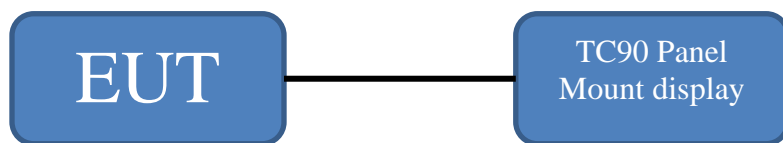

Units of Measurements

AC Line Conducted EMI Data is in dB μ V; dB referenced to one microvolt.

Radiated EMI Data is in dB μ V/m; dB/m referenced to one microvolt per meter

Antenna Conducted Data is in dBm, dB referenced to one milliwatt

Test Site Locations

Conducted EMI Antenna Port conducted emissions testing was performed in a shielded screen room located at Rogers Labs, Inc., 4405 W. 259th Terrace, Louisburg, KS.

Radiated EMI The radiated emissions testing performed at the 3 meters, Open Area Test Site (OATS) located at Rogers Labs, Inc., 4405 W. 259th Terrace, Louisburg, KS.

Registered Site information: FCC Site: US5305 and ISED: 3041A, CAB Identifier: US0096

NVLAP Accreditation Lab code 200087-0

Environmental Conditions

Ambient Temperature 21.8° C

Relative Humidity 36%

Atmospheric Pressure 1022.8 mb

| | | |
|---------------------------|---------------------------------------------------|-------------------------|
| Rogers Labs, Inc. | Trig Avionics Limited | SN: 003 |
| 4405 West 259th Terrace | Model: TY92 | FCC ID: VZI00879 |
| Louisburg, KS 66053 | Test: 211122 | IC: 10614A-00879 |
| Phone/Fax: (913) 837-3214 | Test to: 47CFR 2, 87, and RSS-141 | Date: December 17, 2021 |
| Revision 1 | File: Trig VZI00879 VHF Com C2PC TstRpt 211122 r1 | Page 9 of 28 |

Transmitter Power Output

Measurements Required

Measurements shall be made to establish the radio frequency power delivered by the transmitter into the standard output termination. The power output shall be monitored and recorded, and no adjustment shall be made to the transmitter after the test has begun, except as noted below:

If the power output is adjustable, measurements shall be made for the highest and lowest power levels. Output transmitter power is not user selectable.

Test Arrangement

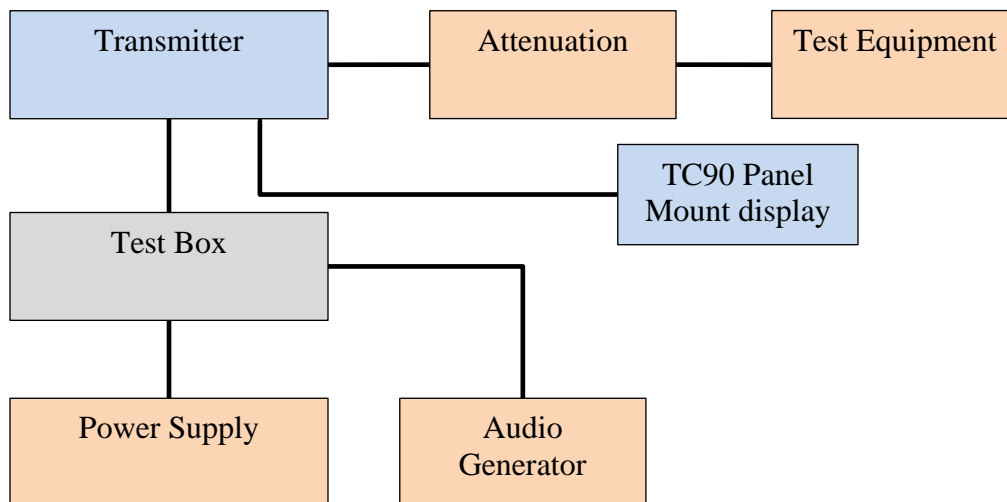

The radio frequency power output was measured at the antenna terminal by placing appropriate attenuation in the antenna line and observing the emission with the spectrum analyzer. The spectrum analyzer and attenuation offered an impedance of 50Ω to match the impedance of the standard antenna. A Rohde & Schwarz ESU40 Spectrum Analyzer was used to measure the radio frequency power at the antenna port. Data was taken in dBm and converted to watts as shown in the following Table. Refer to Figures one and two showing plots of output power of the transmitter across the frequency band. Data was taken per CFR47 Paragraph 2.1046(a) and applicable paragraphs of Part 87 and RSS-141.

P_{dBm} = power in dB above 1 milliwatt
 Milliwatts = $10^{(P_{dBm}/10)}$
 Watts = (Milliwatts)(0.001)(W/mW)
 Milliwatts = $10^{(42.70/10)}$
 = 18,621 mW
 = 18.6 Watts Peak power

Table 1 Transmitter Power Results

| Frequency | Input Voltage | P_w |
|---------------------------------------|---------------|-------|
| VHF Communications (25 kHz Channel) | | |
| 118.000 | 28 | 18.6 |
| 127.000 | 28 | 18.6 |
| 136.975 | 28 | 18.6 |
| VHF Communications (8.33 kHz Channel) | | |
| 118.000 | 28 | 18.6 |
| 127.000 | 28 | 18.6 |
| 136.992 | 28 | 18.6 |

The EUT demonstrated compliance with specifications of CFR47 Paragraph 2.1046(a) and applicable Parts of 2 and 87.131. There are no deviations to the specifications.

Figure 1 Power Output Across Frequency Band 118-136.750 MHz (25 kHz mode)

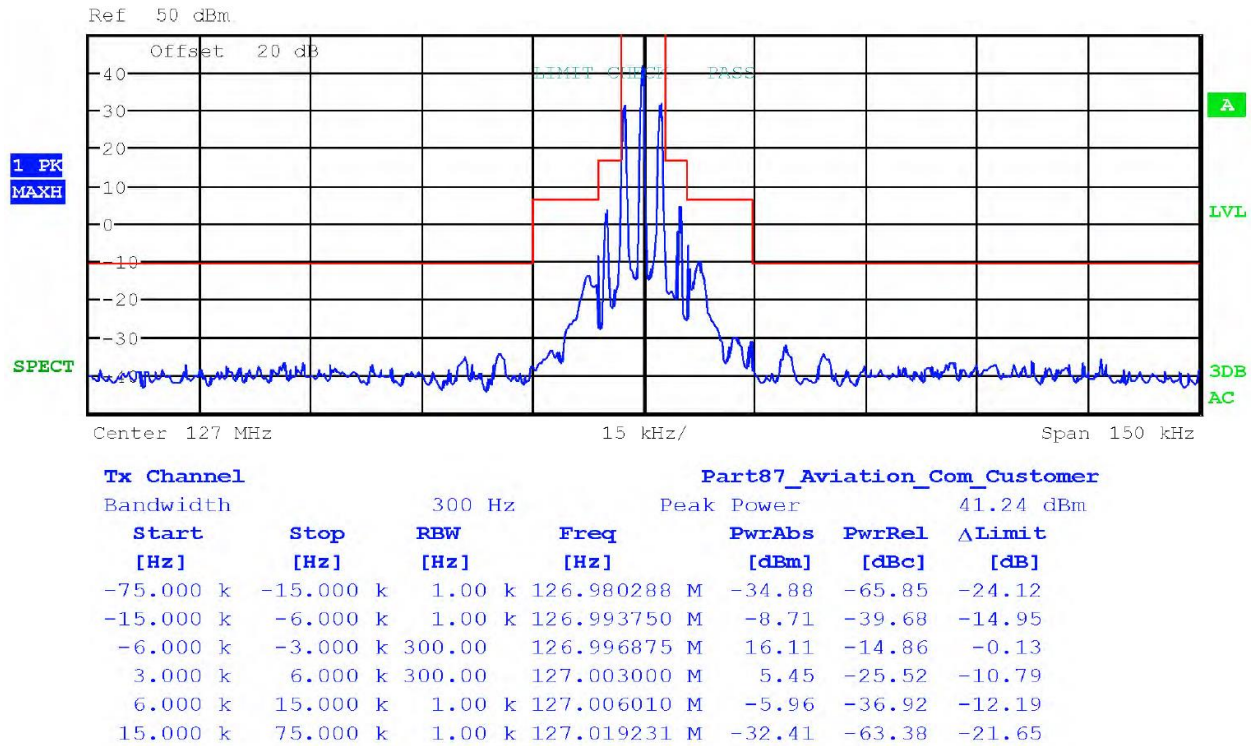
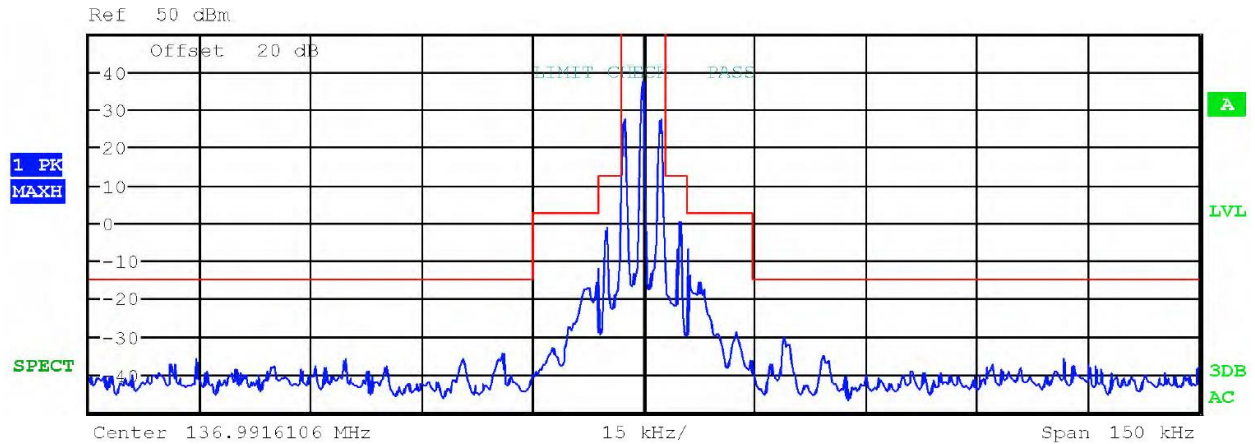

Figure 2 Power Output Across Frequency Band 118-136.750 MHz (8.33 kHz)



| Tx Channel | | | Part87_Aviation_Com_Customer | | | |
|------------|-----------|----------|------------------------------|--------------|--------------|-------------|
| Bandwidth | | 300 Hz | | Peak Power | | 37.19 dBm |
| Start [Hz] | Stop [Hz] | RBW [Hz] | Freq [Hz] | PwrAbs [dBm] | PwrRel [dBc] | ΔLimit [dB] |
| -75.000 k | -15.000 k | 1.00 k | 136.972380 M | -34.53 | -61.46 | -19.73 |
| -15.000 k | -6.000 k | 1.00 k | 136.985361 M | -12.11 | -39.04 | -14.31 |
| -6.000 k | -3.000 k | 300.00 | 136.988486 M | 11.72 | -15.20 | -0.47 |
| 3.000 k | 6.000 k | 300.00 | 136.994611 M | 3.88 | -23.04 | -8.31 |
| 6.000 k | 15.000 k | 1.00 k | 136.997620 M | -7.18 | -34.11 | -9.38 |
| 15.000 k | 75.000 k | 1.00 k | 137.010601 M | -30.31 | -57.23 | -15.50 |

Occupied Bandwidth

Measurements Required

The occupied bandwidth, that is the frequency bandwidth such that below its lower and above its upper frequency limits, the mean powers radiated are equal to 0.5 percent of the total mean power radiated by a given emission.

Test Arrangement

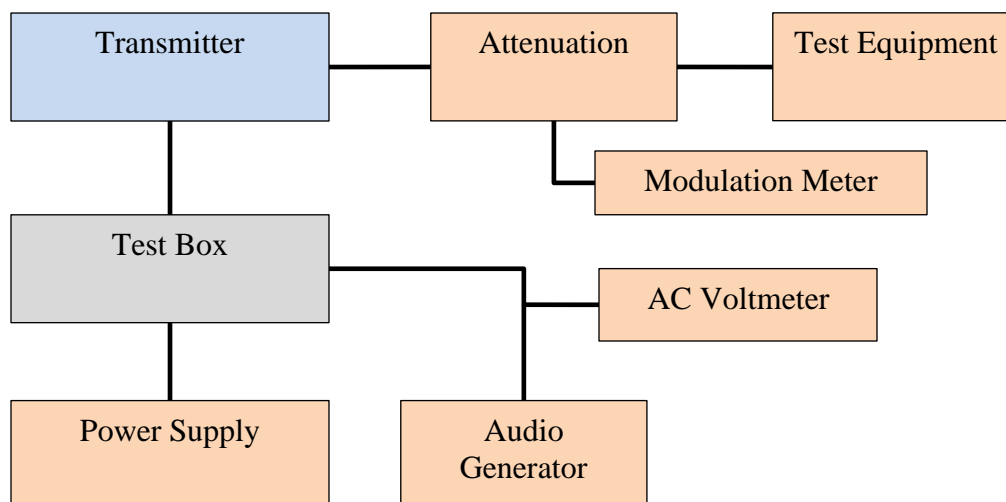

A Rohde & Schwarz ESU 40 spectrum analyzer was used to observe the radio frequency spectrum with the transmitter operating in normal modes. Characteristics for audio communications were obtained with the EUT modulated by a frequency of 2500 Hz at a level 16 dB above 50% modulation. Other modulation schemes were measured using appropriate input signals as defined by other standards. The power ratio in dB representing 99% of the total mean power was recorded from the spectrum analyzer measurements. Refer to figures three and four displaying plots of 99% power occupied bandwidth measurements.

Table 2 Occupied Bandwidth Results

| Frequency (MHz) | Occupied bandwidth (kHz) |
|-------------------------|--------------------------|
| 118.000 (25 kHz mode) | 5.280 |
| 127.500 (25 kHz mode) | 5.280 |
| 136.975 (25 kHz mode) | 5.280 |
| 118.000 (8.33 kHz mode) | 5.280 |
| 127.500 (8.33 kHz mode) | 5.280 |
| 136.992 (8.33 kHz mode) | 5.280 |

The EUT demonstrated compliance with specifications of CFR47 Paragraph 2.1049 and applicable Parts of 2 and 87.135. There are no deviations to the specifications.

Figure 3 Occupied Band Width (25 kHz channels 118.000-136.975 MHz)

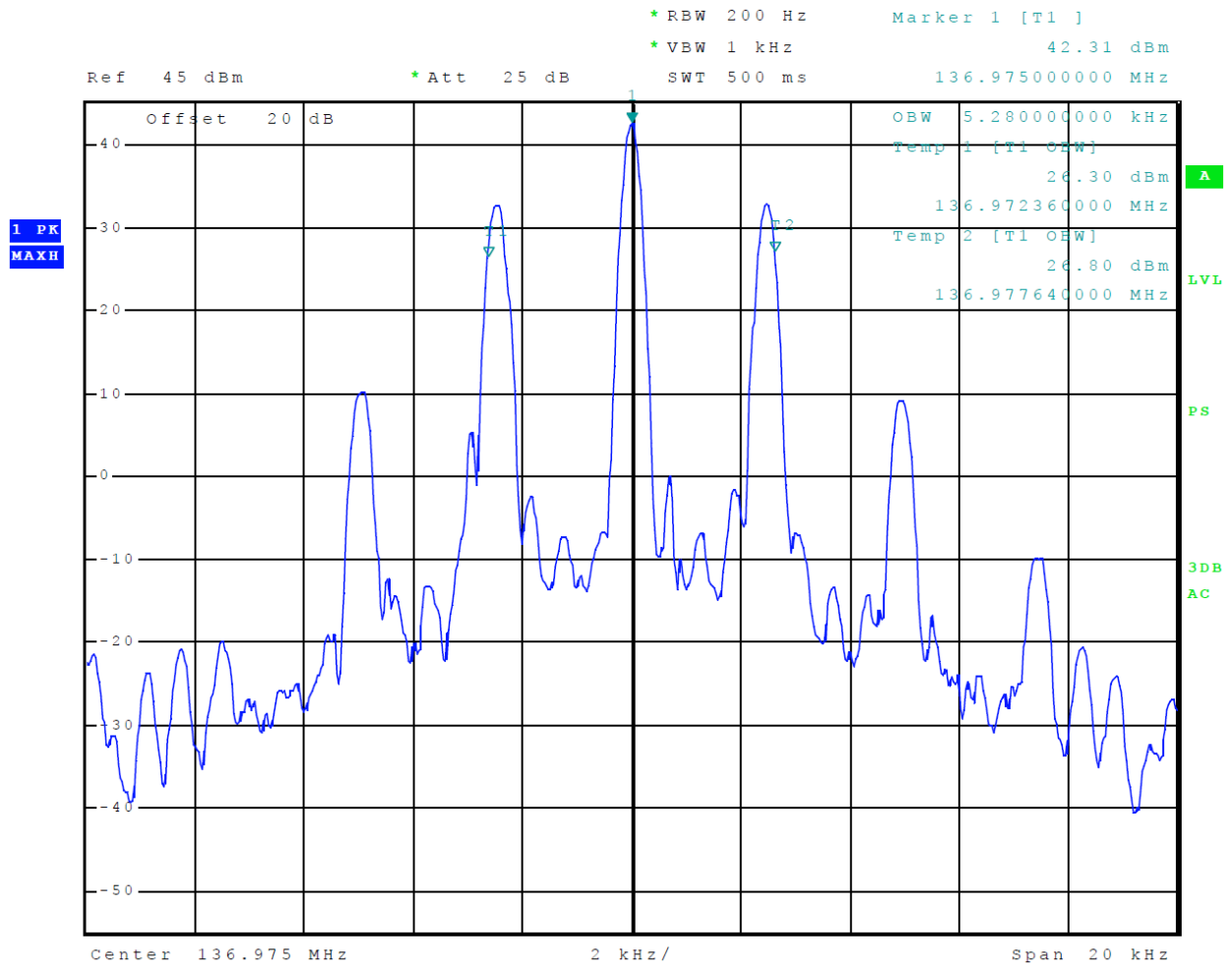
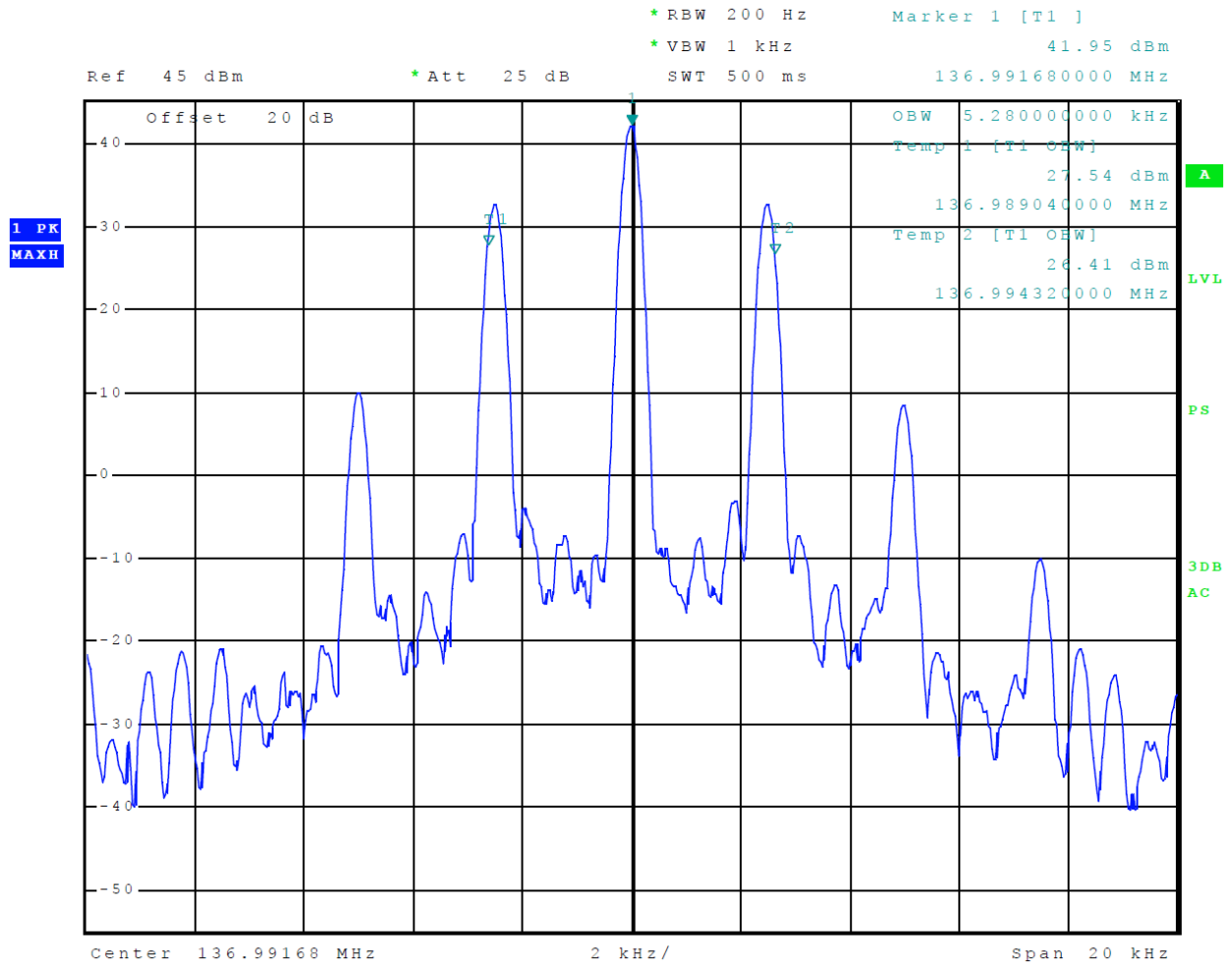

Figure 4 Occupied Band Width (8.33 kHz channels 118.000-136.992 MHz)



Spurious Emissions at Antenna Terminals

Measurements Required

The radio frequency voltage or power generated within the equipment and appearing on a spurious frequency shall be checked at the equipment output terminals when properly loaded with a suitable artificial antenna. All spurious emissions must be attenuated at least $43 + 10 \log (P_o)$ below the fundamental emission power level. The following equations represent the calculated attenuation offset level for the equipment operating with rated output power of 13.0 or 19.0 Watts.

Limit for 8-Watt transmitter

$$\begin{aligned} \text{Limit (dBc)} &= 43 + 10 \text{ Log } (P_o) \\ &= 43 + 10 \text{ Log } (19.0) \\ &= 55.8 \text{ dBc} \end{aligned}$$

Test Arrangement

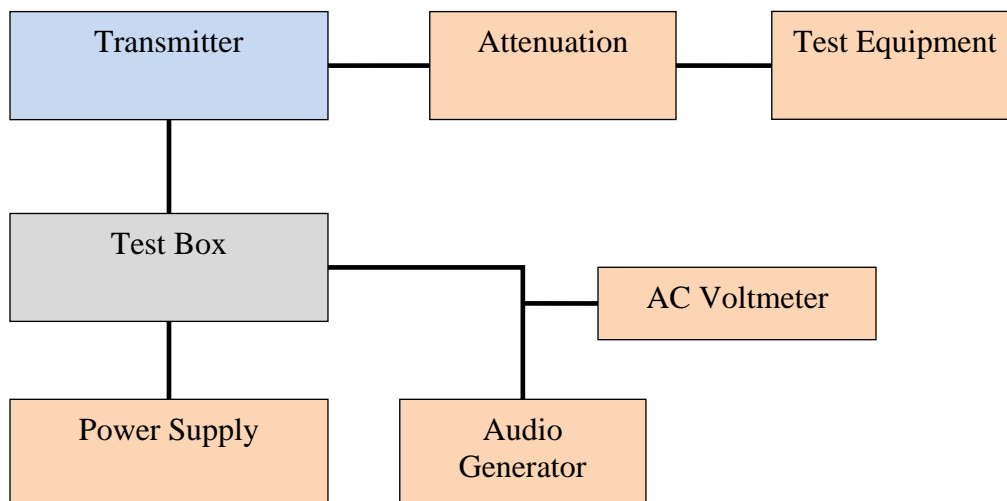

The radio frequency output was coupled to a Rohde & Schwarz ESU40 Spectrum Analyzer during antenna port conducted emissions measurements. The spectrum analyzer was used to observe the radio frequency spectrum with the transmitter modulated per section 2.1049 and operated in all normal modes. The frequency spectrum from 30 MHz to 1,500 MHz was observed and plot produced of the frequency spectrum displayed on the test equipment. Refer to figure five through seven compliance with antenna spurious emissions and Spectral Emission Mask. Data was taken per CFR47 2.1051, 2.1057, and applicable paragraphs of Part 87.139. There are no deviations to the specifications.

Table 3 Spurious Emissions at Antenna Terminal Results

| Channel MHz | Spurious Freq. (MHz) | Measured Level (dBm) | Level Below Carrier (dBc) |
|-------------|----------------------|----------------------|---------------------------|
| 118.000 | 236.0 | -21.10 | -63.6 |
| | 354.0 | -15.40 | -57.9 |
| | 472.0 | -32.80 | -75.3 |
| | 590.0 | -34.10 | -76.6 |
| | 708.0 | -34.00 | -76.5 |
| | 826.0 | -36.60 | -79.1 |
| 127.000 | 254.0 | -21.70 | -64.5 |
| | 381.0 | -15.40 | -58.2 |
| | 508.0 | -33.40 | -76.2 |
| | 635.0 | -33.90 | -76.7 |
| | 762.0 | -34.10 | -76.9 |
| | 889.0 | -31.30 | -74.1 |
| 136.975 | 274.0 | -21.30 | -63.4 |
| | 410.9 | -18.00 | -60.1 |
| | 547.9 | -34.00 | -76.1 |
| | 684.9 | -33.70 | -75.8 |
| | 821.9 | -33.30 | -75.4 |
| | 958.8 | -33.20 | -75.3 |

Figure 5 Spurious Emissions at Antenna Terminal

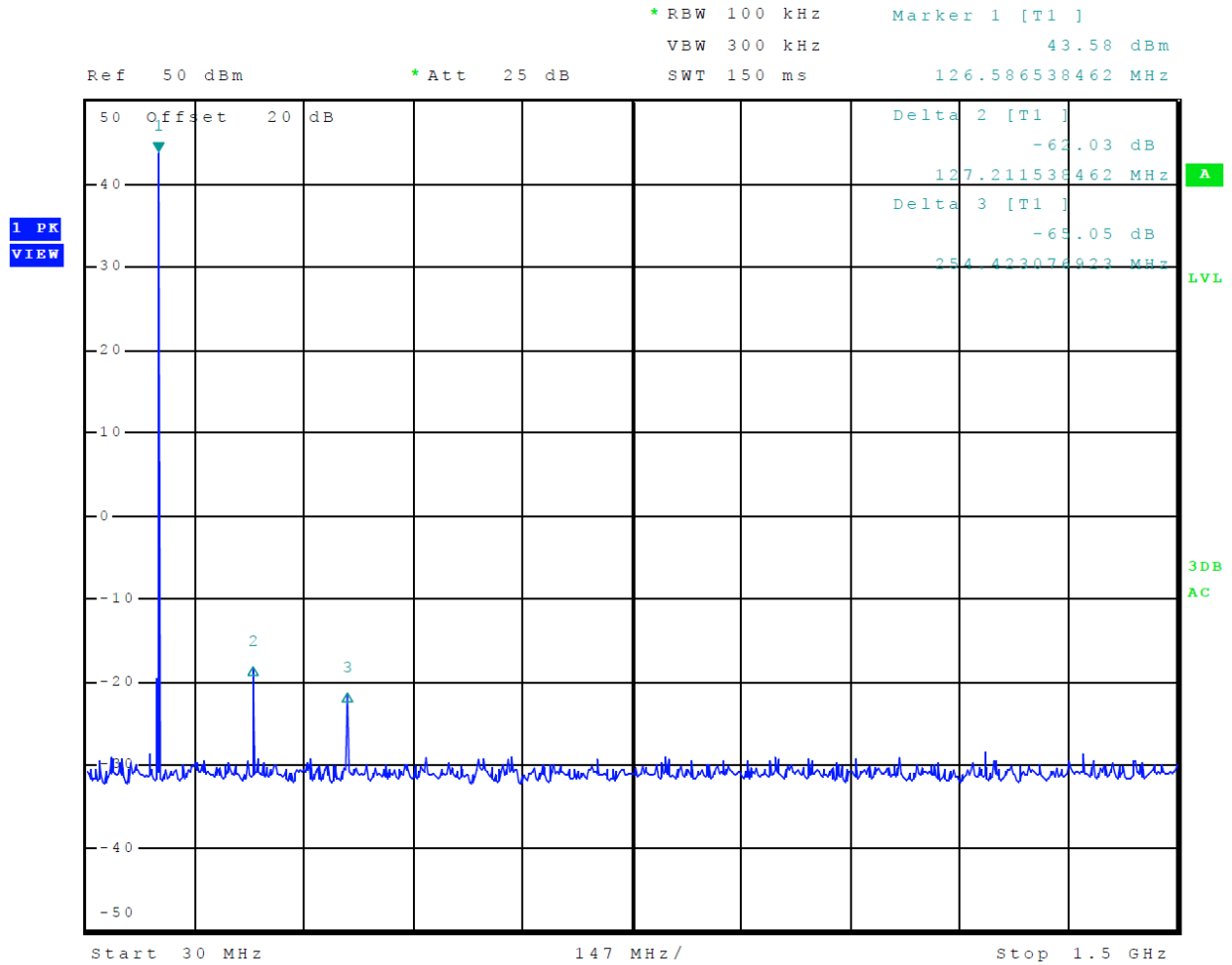

Figure 6 Spurious Emissions at Antenna Terminal

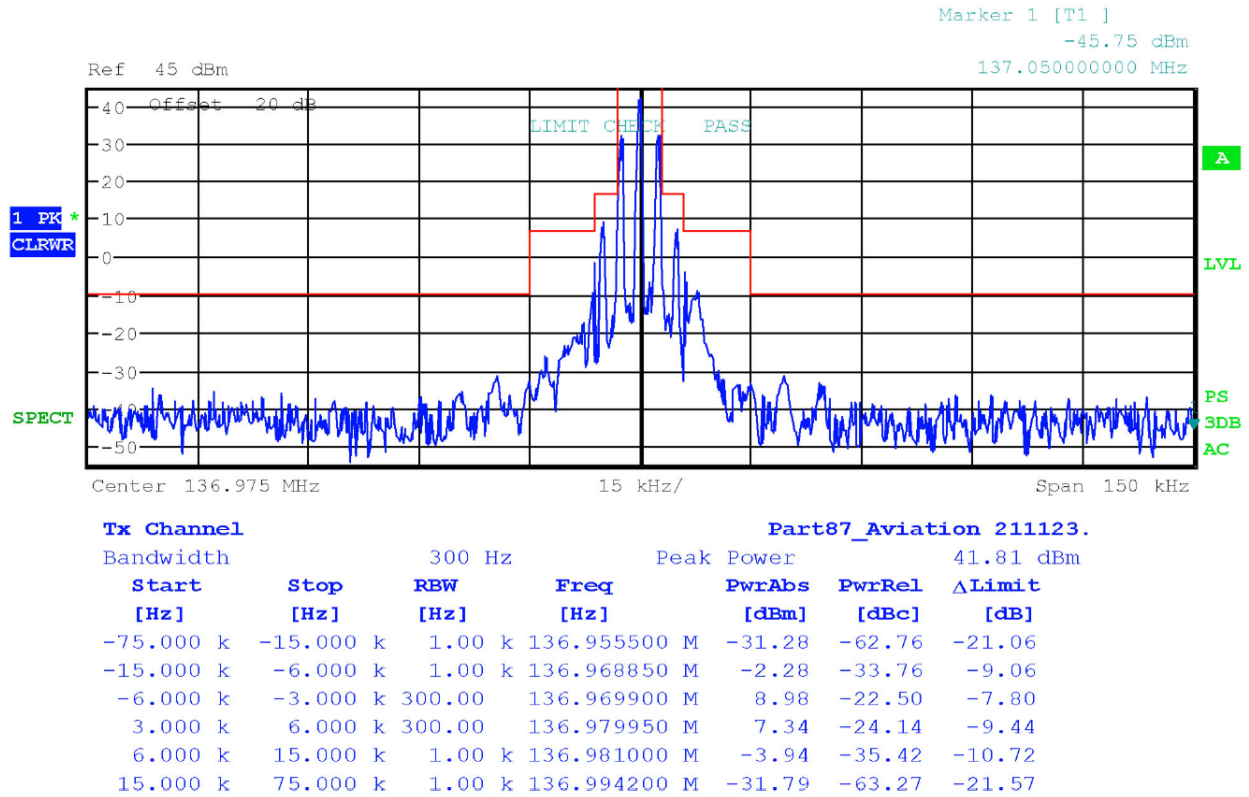
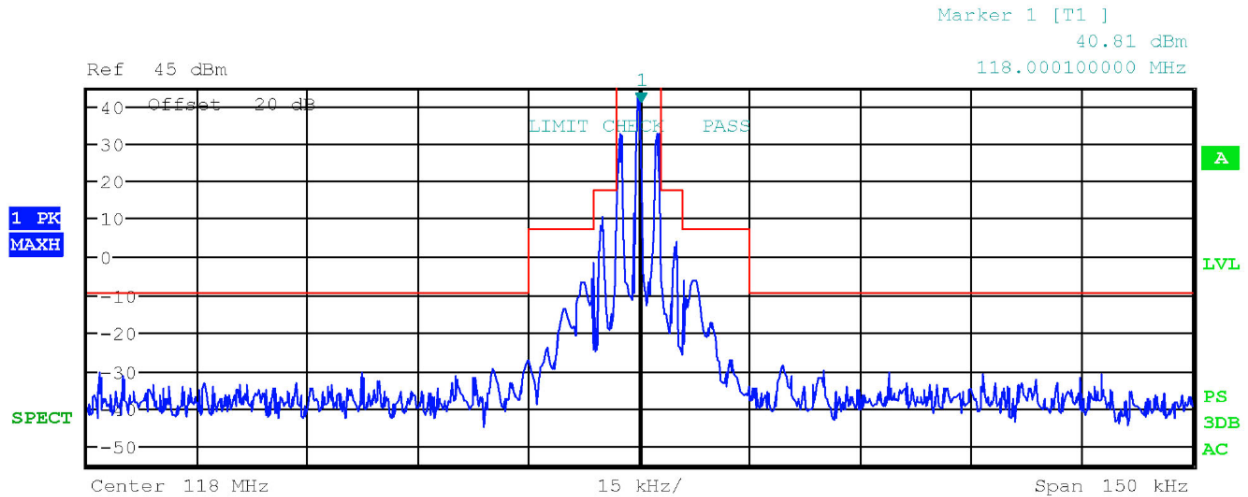

Figure 7 Spectral Emission Mask at Antenna Terminal



| Tx Channel | | | Part87_Aviation 211123. | | | |
|------------|-----------|--------|-------------------------|------------|-----------|--------|
| Bandwidth | | 300 Hz | | Peak Power | 42.44 dBm | |
| Start | Stop | RBW | Freq | PwrAbs | PwrRel | ΔLimit |
| [Hz] | [Hz] | [Hz] | [Hz] | [dBm] | [dBc] | [dB] |
| -75.000 k | -15.000 k | 1.00 k | 117.984850 M | -28.23 | -60.30 | -18.67 |
| -15.000 k | -6.000 k | 1.00 k | 117.993850 M | -1.63 | -33.70 | -9.07 |
| -6.000 k | -3.000 k | 300.00 | 117.994900 M | 10.37 | -21.70 | -7.07 |
| 3.000 k | 6.000 k | 300.00 | 118.003000 M | 5.05 | -27.02 | -12.39 |
| 6.000 k | 15.000 k | 1.00 k | 118.006000 M | -6.38 | -38.45 | -13.82 |
| 15.000 k | 75.000 k | 1.00 k | 118.019350 M | -29.13 | -61.20 | -19.57 |

Annex

- Annex A Measurement Uncertainty Calculations
- Annex B Test Equipment List
- Annex C Rogers Qualifications
- Annex D Laboratory Certificate of Accreditation

Rogers Labs, Inc.

4405 West 259th Terrace

Louisburg, KS 66053

Phone/Fax: (913) 837-3214

Revision 1

Trig Avionics Limited

Model: TY92

Test: 211122

Test to: 47CFR 2, 87, and RSS-141

File: Trig VZI00879 VHF Com C2PC TstRpt 211122 r1

SN: 003

FCC ID: VZI00879

IC: 10614A-00879

Date: December 17, 2021

Page 23 of 28

Annex A Measurement Uncertainty Calculations

The measurement uncertainty was calculated for all measurements listed in this test report according To CISPR 16-4. Result of measurement uncertainty calculations are recorded below. Component and process variability of production devices similar to those tested may result in additional deviations. The manufacturer has the sole responsibility of continued compliance.

| Measurement | Expanded Measurement Uncertainty $U_{(lab)}$ |
|-------------------------------------------------|----------------------------------------------|
| 3 Meter Horizontal 0.009-1000 MHz Measurements | 4.16 |
| 3 Meter Vertical 0.009-1000 MHz Measurements | 4.33 |
| 3 Meter Measurements 1-18 GHz | 5.14 |
| 3 Meter Measurements 18-40 GHz | 5.16 |
| 10 Meter Horizontal Measurements 0.009-1000 MHz | 4.15 |
| 10 Meter Vertical Measurements 0.009-1000 MHz | 4.32 |
| AC Line Conducted | 1.75 |
| Antenna Port Conducted power | 1.17 |
| Frequency Stability | 1.00E-11 |
| Temperature | 1.6°C |
| Humidity | 3% |

Annex B Test Equipment List

| <u>Equipment</u> | <u>Manufacturer</u> | <u>Model (SN)</u> | <u>Band</u> | <u>Cal Date(m/d/y)</u> | <u>Due</u> |
|-----------------------------------------------------|---------------------|---------------------------------|--------------|------------------------|------------|
| <input type="checkbox"/> LISN | FCC | FCC-LISN-50-25-10(1PA) (160611) | .15-30MHz | 4/6/2021 | 4/6/2022 |
| <input type="checkbox"/> LISN | Compliance Design | FCC-LISN-2.Mod.cd,(126) | .15-30MHz | 10/14/2021 | 10/14/2022 |
| <input checked="" type="checkbox"/> Cable | Huber & Suhner Inc. | Sucoflex102ea(L10M)(303073) | 9kHz-40 GHz | 10/14/2021 | 10/14/2022 |
| <input type="checkbox"/> Cable | Huber & Suhner Inc. | Sucoflex102ea(1.5M)(303069) | 9kHz-40 GHz | 10/14/2021 | 10/14/2022 |
| <input checked="" type="checkbox"/> Cable | Huber & Suhner Inc. | Sucoflex102ea(1.5M)(303070) | 9kHz-40 GHz | 10/14/2021 | 10/14/2022 |
| <input type="checkbox"/> Cable | Belden | RG-58 (L1-CAT3-11509) | 9kHz-30 MHz | 10/14/2021 | 10/14/2022 |
| <input type="checkbox"/> Cable | Belden | RG-58 (L2-CAT3-11509) | 9kHz-30 MHz | 10/14/2021 | 10/14/2022 |
| <input type="checkbox"/> Antenna | Com Power | AL-130 (121055) | .001-30 MHz | 10/14/2021 | 10/14/2022 |
| <input type="checkbox"/> Antenna: | EMCO | 6509 | .001-30 MHz | 10/14/2020 | 10/14/2022 |
| <input type="checkbox"/> Antenna | ARA | BCD-235-B (169) | 20-350MHz | 10/14/2021 | 10/14/2022 |
| <input type="checkbox"/> Antenna: | Schwarzbeck Model | VHBB 9124 (1468) | | 10/14/2020 | 10/14/2022 |
| <input type="checkbox"/> Antenna | Sunol | JB-6 (A100709) | 30-1000 MHz | 10/14/2021 | 10/14/2022 |
| <input type="checkbox"/> Antenna | ETS-Lindgren | 3147 (40582) | 200-1000MHz | 10/14/2020 | 10/14/2022 |
| <input type="checkbox"/> Antenna: | Schwarzbeck Model: | VULP 9118 A (VULP 9118 A-534) | | 10/14/2020 | 10/14/2022 |
| <input type="checkbox"/> Antenna | ETS-Lindgren | 3117 (200389) | 1-18 GHz | 4/21/2020 | 4/21/2022 |
| <input type="checkbox"/> Antenna | Com Power | AH-118 (10110) | 1-18 GHz | 10/14/2020 | 10/14/2022 |
| <input type="checkbox"/> Antenna | Com Power | AH-840 (101046) | 18-40 GHz | 4/6/2021 | 4/6/2023 |
| <input checked="" type="checkbox"/> Analyzer | Rohde & Schwarz | ESU40 (100108) | 20Hz-40GHz | 5/20/2021 | 5/20/2022 |
| <input checked="" type="checkbox"/> Analyzer | Rohde & Schwarz | ESW44 (101534) | 20Hz-44GHz | 1/12/2021 | 1/12/2022 |
| <input type="checkbox"/> Analyzer | Rohde & Schwarz | FS-Z60, 90, 140, and 220 | 40GHz-220GHz | 12/22/2017 | 12/22/2027 |
| <input type="checkbox"/> Amplifier | Com-Power | PA-010 (171003) | 100Hz-30MHz | 10/14/2021 | 10/14/2022 |
| <input type="checkbox"/> Amplifier | Com-Power | CPPA-102 (01254) | 1-1000 MHz | 10/14/2021 | 10/14/2022 |
| <input type="checkbox"/> Amplifier | Com-Power | PAM-118A (551014) | 0.5-18 GHz | 10/14/2021 | 10/14/2022 |
| <input type="checkbox"/> Amplifier | Com-Power | PAM-840A (461328) | 18-40 GHz | 10/14/2021 | 10/14/2022 |
| <input type="checkbox"/> Power Meter | Agilent | N1911A with N1921A | 0.05-40 GHz | 4/6/2021 | 4/6/2022 |
| <input type="checkbox"/> Generator | Rohde & Schwarz | SMB100A6 (100150) | 20Hz-6 GHz | 4/6/2021 | 4/6/2022 |
| <input type="checkbox"/> Generator | Rohde & Schwarz | SMBV100A6 (260771) | 20Hz-6 GHz | 4/6/2021 | 4/6/2022 |
| <input type="checkbox"/> RF Filter | Micro-Tronics | BRC50722 (009).9G notch | 30-18000 MHz | 4/6/2021 | 4/6/2022 |
| <input type="checkbox"/> RF Filter | Micro-Tronics | HPM50114 (017)1.5G HPF | 30-18000 MHz | 4/6/2021 | 4/6/2022 |
| <input type="checkbox"/> RF Filter | Micro-Tronics | HPM50117 (063) 3G HPF | 30-18000 MHz | 4/6/2021 | 4/6/2022 |
| <input type="checkbox"/> RF Filter | Micro-Tronics | HPM50105 (059) 6G HPF | 30-18000 MHz | 4/6/2021 | 4/6/2022 |
| <input type="checkbox"/> RF Filter | Micro-Tronics | BRM50702 (172) 2G notch | 30-18000 MHz | 4/6/2021 | 4/6/2022 |
| <input type="checkbox"/> RF Filter | Micro-Tronics | BRC50703 (G102) 5G notch | 30-18000 MHz | 4/6/2021 | 4/6/2022 |
| <input type="checkbox"/> RF Filter | Micro-Tronics | BRC50705 (024) 5G notch | 30-18000 MHz | 4/6/2021 | 4/6/2022 |
| <input type="checkbox"/> Attenuator | Fairview | SA6NFN100W-40 (1625) | 30-18000 MHz | 4/6/2021 | 4/6/2022 |
| <input type="checkbox"/> Attenuator | Mini-Circuits | VAT-3W2+ (1436) | 30-6000 MHz | 4/6/2021 | 4/6/2022 |
| <input type="checkbox"/> Attenuator | Mini-Circuits | VAT-3W2+ (1445) | 30-6000 MHz | 4/6/2021 | 4/6/2022 |
| <input type="checkbox"/> Attenuator | Mini-Circuits | VAT-3W2+ (1735) | 30-6000 MHz | 4/6/2021 | 4/6/2022 |
| <input type="checkbox"/> Attenuator | Mini-Circuits | VAT-6W2+ (1438) | 30-6000 MHz | 4/6/2021 | 4/6/2022 |
| <input type="checkbox"/> Attenuator | Mini-Circuits | VAT-6W2+ (1736) | 30-6000 MHz | 4/6/2021 | 4/6/2022 |
| <input checked="" type="checkbox"/> Weather station | Davis | 6312 (A81120N075) | | 11/4/2020 | 11/4/2021 |

Rogers Labs, Inc. Trig Avionics Limited SN: 003
 4405 West 259th Terrace Model: TY92 FCC ID: VZI00879
 Louisburg, KS 66053 Test: 211122 IC: 10614A-00879
 Phone/Fax: (913) 837-3214 Test to: 47CFR 2, 87, and RSS-141 Date: December 17, 2021
 Revision 1 File: Trig VZI00879 VHF Com C2PC TstRpt 211122 r1 Page 25 of 28

| List of Test Equipment | Calibration | Date (m/d/y) | Due |
|--------------------------------------------------------------------------------------------|-------------|--------------|--------------|
| <input type="checkbox"/> Antenna: Schwarzbeck Model VHBB 9124 (9124-627) | | 4/21/2020 | 4/21/2022 |
| <input type="checkbox"/> Antenna: Schwarzbeck Model: VULP 9118 A (VULP 9118 A-534) | | 4/21/2020 | 4/21/2022 |
| <input type="checkbox"/> Frequency Counter: Leader LDC-825 (8060153) | | 4/6/2021 | 4/6/2022 |
| <input type="checkbox"/> LISN: Com-Power Model LI-220A | | 10/14/2020 | 10/14/2022 |
| <input type="checkbox"/> LISN: Com-Power Model LI-550C | | 10/14/2020 | 10/14/2022 |
| <input type="checkbox"/> ISN: Com-Power Model ISN T-8 | | 4/6/2021 | 4/6/2022 |
| <input type="checkbox"/> LISN: Fischer Custom Communications Model: FCC-LISN-50-16-2-08 | | 4/6/2021 | 4/6/2022 |
| <input type="checkbox"/> Cable Huber & Suhner Inc. Sucoflex102ea(1.5M)(303072) 9kHz-40 GHz | | 10/14/2021 | 10/14/2022 |
| <input type="checkbox"/> Cable Huber & Suhner Inc. Sucoflex102ea(L1M)(281183) 9kHz-40 GHz | | 10/14/2021 | 10/14/2022 |
| <input type="checkbox"/> Cable Huber & Suhner Inc. Sucoflex102ea(L4M)(281184) 9kHz-40 GHz | | 10/14/2021 | 10/14/2022 |
| <input type="checkbox"/> Cable Huber & Suhner Inc. Sucoflex102ea(L10M)(317546)9kHz-40 GHz | | 10/14/2021 | 10/14/2022 |
| <input type="checkbox"/> Cable Time Microwave 4M-750HF290-750 (4M) 9kHz-24 GHz | | 10/14/2021 | 10/14/2022 |
| <input type="checkbox"/> RF Filter Micro-Tronics BRC17663 (001) 9.3-9.5 notch 30-1800 MHz | | 4/6/2021 | 4/6/2022 |
| <input type="checkbox"/> RF Filter Micro-Tronics BRC19565 (001) 9.2-9.6 notch 30-1800 MHz | | 10/16/2018 | 4/6/2022 |
| <input type="checkbox"/> Analyzer HP 8562A (3051A05950) 9kHz-125GHz | | 4/6/2021 | 4/6/2022 |
| <input type="checkbox"/> Wave Form Generator Keysight 33512B (MY57400128) | | 4/21/2020 | 4/6/2022 |
| <input type="checkbox"/> Antenna: Solar 9229-1 & 9230-1 | | 2/22/2021 | 2/22/2022 |
| <input type="checkbox"/> CDN: Com-Power Model CDN325E | | 10/14/2021 | 10/14/2022 |
| <input type="checkbox"/> Injection Clamp Luthi Model EM101 | | 10/14/2021 | 10/14/2022 |
| <input type="checkbox"/> Oscilloscope Scope: Tektronix MDO 4104 | | 2/22/2021 | 2/22/2022 |
| <input type="checkbox"/> EMC Transient Generator HVT TR 3000 | | 2/22/2021 | 2/22/2022 |
| <input type="checkbox"/> AC Power Source (Ametech, California Instruments) | | 2/22/2021 | 2/22/2022 |
| <input type="checkbox"/> Field Intensity Meter: EFM-018 | | 2/22/2021 | 2/22/2022 |
| <input type="checkbox"/> ESD Simulator: MZ-15 | | 2/22/2021 | 2/22/2022 |
| <input type="checkbox"/> R.F. Power Amp ACS 230-50W | | | not required |
| <input type="checkbox"/> R.F. Power Amp EIN Model: A301 | | | not required |
| <input type="checkbox"/> R.F. Power Amp A.R. Model: 10W 1010M7 | | | not required |
| <input type="checkbox"/> R.F. Power Amp A.R. Model: 50U1000 | | | not required |
| <input type="checkbox"/> Tenney Temperature Chamber | | | not required |
| <input checked="" type="checkbox"/> Shielded Room | | | not required |

Rogers Labs, Inc. Trig Avionics Limited SN: 003
 4405 West 259th Terrace Model: TY92 FCC ID: VZI00879
 Louisburg, KS 66053 Test: 211122 IC: 10614A-00879
 Phone/Fax: (913) 837-3214 Test to: 47CFR 2, 87, and RSS-141 Date: December 17, 2021
 Revision 1 File: Trig VZI00879 VHF Com C2PC TstRpt 211122 r1 Page 26 of 28

Annex C Rogers Qualifications

Scot D. Rogers, Engineer

Mr. Rogers has over 35 years' experience in the field of electronics. Engineering experience includes six years in the automated controls industry and remaining years working with the design, development and testing of radio communications and electronic equipment.

Positions Held:

Systems Engineer: A/C Controls Mfg. Co., Inc.

Electrical Engineer: Rogers Consulting Labs, Inc.

Electrical Engineer: Rogers Labs, Inc. Current

Educational Background:

Bachelor of Science Degree in Electrical Engineering from Kansas State University

Bachelor of Science Degree in Business Administration Kansas State University

Several Specialized Training courses and seminars pertaining to Microprocessors and Software programming

Annex D Laboratory Certificate of Accreditation

United States Department of Commerce
National Institute of Standards and Technology

Certificate of Accreditation to ISO/IEC 17025:2017

NVLAP LAB CODE: 200087-0

Rogers Labs, Inc.
Louisburg, KS

*is accredited by the National Voluntary Laboratory Accreditation Program for specific services,
listed on the Scope of Accreditation, for:*

Electromagnetic Compatibility & Telecommunications

*This laboratory is accredited in accordance with the recognized International Standard ISO/IEC 17025:2017.
This accreditation demonstrates technical competence for a defined scope and the operation of a laboratory quality
management system (refer to joint ISO-ILAC-IAF Communique dated January 2009).*

2021-02-19 through 2022-03-31
Effective Dates



For the National Voluntary Laboratory Accreditation Program