



## Test Report

Product Name : Multi-service Wireless Office Gateway  
Model No. : MSG100  
FCC ID : VZ9MSG100G001

Applicant : 4IPNET, INC.

Address : 38129 Cambridge Court, Fremont, California  
94536, USA

Date of Receipt : 2007/05/24

Issued Date : 2008/02/18

Report No. : 082168R-ITUSP02V02

Version : V1.0

The test results relate only to the samples tested.

The test results shown in the test report are traceable to the national/international standard through the calibration of the equipment and evaluated measurement uncertainty herein.

This report must not be used to claim product endorsement by TAF, NVLAP, NIST or any agency of the Government.

The test report shall not be reproduced except in full without the written approval of QuieTek Corporation.

Test Report Certification

Issued Date : 2008/02/18
Report No. : 082168R-ITUSP02V02



Product Name : Multi-service Wireless Office Gateway
Applicant : 4IPNET, INC.
Address : 38129 Cambridge Court, Fremont, California 94536, USA
Manufacturer : 4IPNET, INC.
Model No. : MSG100
Rated Voltage : AC 120 V / 60 Hz
EUT Voltage : AC 100-240V, 50-60Hz
Trade Name : 4IPNET
Applicable Standard : FCC CFR Title 47 Part 15 Subpart B: 2007 Class B
CISPR 22: 2005
ANSI C63.4: 2003
ICES-003 Issue 4: 2004 Class B
Test Result : Complied
Performed Location : Quietek Corporation (Linkou Laboratory)
No.5-22,Ruei-Shu Valley, Ruei-Ping Tsuen Lin Kuo Shiang,
Taipei, 244 Taiwan, R.O.C.
TEL:+866-2-8601-3788 / FAX:+886-2-8601-3789

Documented By : Joanne Lin
( Engineering Adm. Assistant /Joanne Lin )
Reviewed By : Leo Lin
( Senior Engineer / Leo Lin )
Approved By : Vincent Lin
( Deputy Manager / Vincent Lin )

## Laboratory Information

We , **Quietek Corporation**, are an independent EMC and safety consultancy that was established the whole facility in our laboratories. The test facility has been accredited/accepted (audited or listed) by the following related bodies in compliance with ISO 17025, EN 45001 and specified testing scopes:

<b>Taiwan R.O.C.</b>	<b>:</b>	<b>BSMI, NCC, TAF</b>
<b>Germany</b>	<b>:</b>	<b>TUV Rheinland</b>
<b>Norway</b>	<b>:</b>	<b>Nemko, DNV</b>
<b>USA</b>	<b>:</b>	<b>FCC, NVLAP</b>
<b>Japan</b>	<b>:</b>	<b>VCCI</b>

The related certificate for our laboratories about the test site and management system can be downloaded from Quietek Corporation's Web Site : <http://tw.quietek.com/modules/enterprise/services.php?item=100>  
 The address and introduction of Quietek Corporation's laboratories can be founded in our Web site : <http://www.quietek.com/>

If you have any comments, Please don't hesitate to contact us. Our contact information is as below:

### HsinChu Testing Laboratory :

No.75-2, 3rd Lin, Wangye Keng, Yonghxing Tsuen, Qionglin Shiang, Hsinchu County 307, Taiwan, R.O.C.  
 TEL:+886-3-592-8858 / FAX:+886-3-592-8859 E-Mail : [service@quietek.com](mailto:service@quietek.com)



### LinKou Testing Laboratory :

No. 5, Ruei-Shu Valley, Ruei-Ping Tsuen, Lin-Kou Shiang, Taipei, Taiwan, R.O.C.  
 TEL : 886-2-8601-3788 / FAX : 886-2-8601-3789 E-Mail : [service@quietek.com](mailto:service@quietek.com)



### Reports from Both Laboratories Are Accepted by :



TABLE OF CONTENTS

Description	Page
1. General Information .....	5
1.1. EUT Description.....	5
1.2. Mode of Operation .....	6
1.3. Tested System Details .....	7
1.4. Configuration of Tested System .....	8
1.5. EUT Exercise Software.....	9
2. Technical Test .....	10
2.1. Summary of Test Result.....	10
2.2. List of Test Equipment .....	11
2.3. Measurement Uncertainty.....	12
2.4. Test Environment.....	13
3. Conducted Emission .....	14
3.1. Test Specification .....	14
3.2. Test Setup.....	14
3.3. Limit.....	14
3.4. Test Procedure .....	15
3.5. Test Result.....	16
3.6. Test Photograph .....	22
4. Radiated Emission.....	22
4.1. Test Specification .....	23
4.2. Test Setup.....	23
4.3. Limit.....	24
4.4. Test Procedure .....	25
4.5. Test Result.....	26
4.6. Test Photograph .....	28
5. Attachment.....	29
EUT Photograph.....	29

## 1. General Information

### 1.1. EUT Description

Product Name	Multi-service Wireless Office Gateway
Trade Name	4IPNET
Model No.	MSG100

Component	
Power Cord	Non-Shielded, 1.8m
Power Adapter	MFR: DVE, M/N: DSA-36W-12124 Input: AC100-240V, 50-60Hz Output: DC 12V Cable Out: Non-Shielded, 1.8m Power Cord: Non-Shielded, 1.8m

**1.2. Mode of Operation**

Quietek has verified the construction and function in typical operation. All the test modes were carried out with the EUT in normal operation, which was shown in this test report and defined as:

Pre-Test Mode	
Mode 1: Normal Operation	
Final Test Mode	
Emission	Mode 1: Normal Operation

**1.3. Tested System Details**

The types for all equipments, plus descriptions of all cables used in the tested system (including inserted cards) are:

Product		Manufacturer	Model No.	Serial No.	Power Cord
1	Notebook PC	DELL	PPT	N/A	Non-Shielded, 0.8m
2	Notebook PC	DELL	PP18L	42649348672	Non-Shielded, 0.8m

1.4. Configuration of Tested System

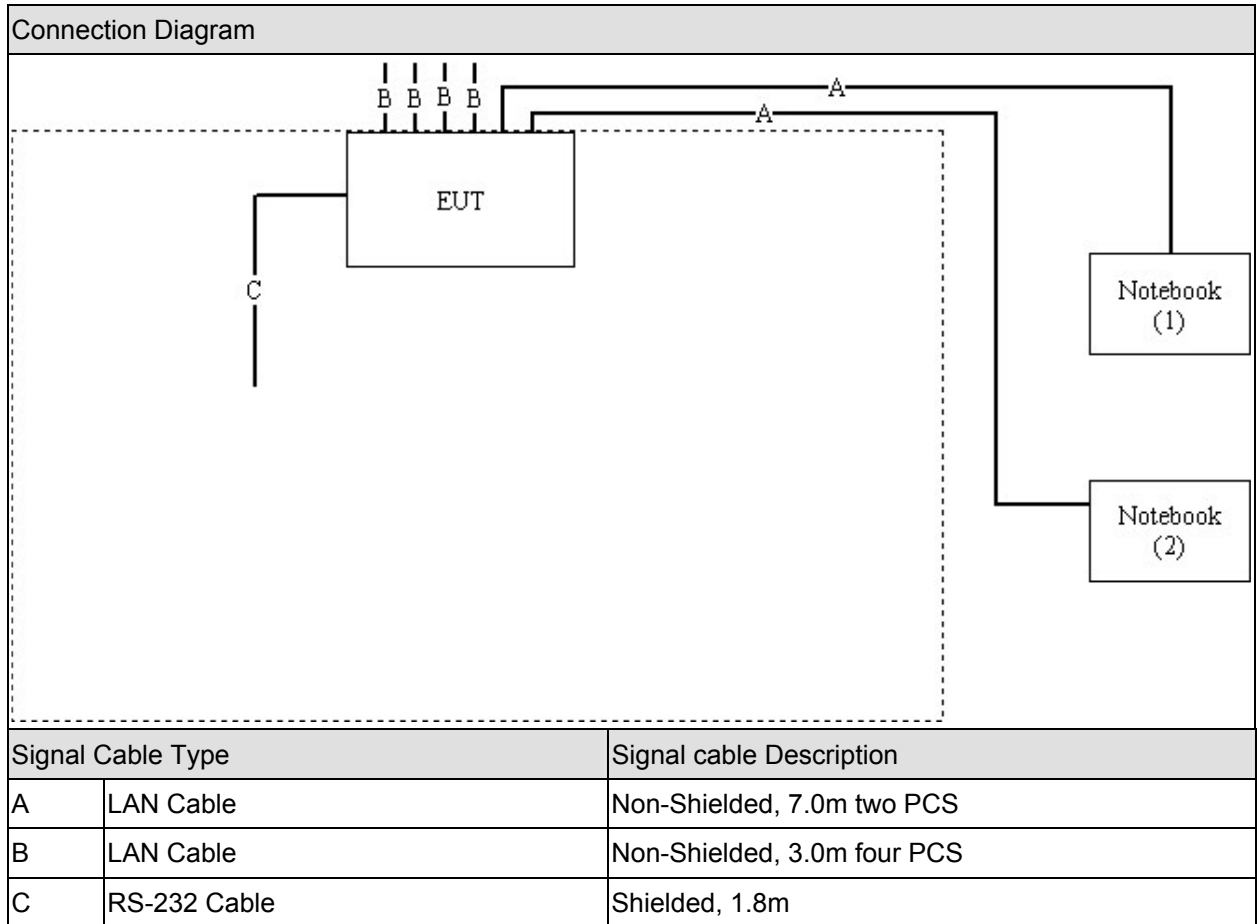



**1.5. EUT Exercise Software**

1	Setup the EUT and simulators as shown on 1.4.
2	Turn on the power of all equipment.
3	Boot the PC from Hard Disk.
4	Data will communicate between personal computer and partner personal computer through EUT.
5	The personal computer's monitor will show the transmitting and receiving characteristics when the communication is success.
6	Repeat the above procedure (4) to (5).

**2. Technical Test**

**2.1. Summary of Test Result**

- No deviations from the test standards
- Deviations from the test standards as below description:

Emission			
Performed Item	Normative References	Test Performed	Deviation
Conducted Emission	FCC CFR Title 47 Part 15 Subpart B: 2007 Class B ANSI C63.4: 2003	Yes	No
Radiated Emission	FCC CFR Title 47 Part 15 Subpart B: 2007 Class B ANSI C63.4: 2003	Yes	No

## 2.2. List of Test Equipment

### Conducted Emission / SR1

Instrument	Manufacturer	Type No.	Serial No	Cal. Date
EMI Test Receiver	R&S	ESCS 30	836858/022	2007/02/12
LISN	R&S	ESH3-Z5	836679/020	2007/01/26
LISN	R&S	ENV4200	833209/007	2006/07/13
Pulse Limiter	R&S	ESH3-Z2	357.88.10.52	2006/09/04

### Radiated Emission / Site3

Instrument	Manufacturer	Type No.	Serial No	Cal. Date
Bilog Antenna	Schaffner Chase	CBL6112B	2704	2006/08/09
Broadband Horn Antenna	Schwarzbeck	BBHA9170	208	2006/07/25
EMI Test Receiver	R&S	ESI26	838786/004	2006/06/19
EMI Test Receiver	R&S	ESCS 30	838251/001	2007/05/11
Horn Antenna	Schwarzbeck	BBHA9120D	305	2006/08/10
Pre-Amplifier	MITEQ	AMF-4D-18040 0-45-6P	925974	2007/01/03
Pre-Amplifier	QTK	N/A	N/A	2007/01/03
Spectrum Analyzer	Advantest	R3162	101102468	2006/10/24

### **2.3. Measurement Uncertainty**

#### Conducted Emission

The measurement uncertainty is evaluated as  $\pm 2.26$  dB.

#### Radiated Emission

The measurement uncertainty is evaluated as  $\pm 3.19$  dB.

**2.4. Test Environment**

Performed Item	Items	Required	Actual
Conducted Emission	Temperature (°C)	15-35	25
	Humidity (%RH)	25-75	50
	Barometric pressure (mbar)	860-1060	950-1000
Radiated Emission	Temperature (°C)	15-35	25
	Humidity (%RH)	25-75	50
	Barometric pressure (mbar)	860-1060	950-1000

### 3. Conducted Emission

#### 3.1. Test Specification

According to Standard : FCC Part 15 Subpart B, ANSI C63.4

#### 3.2. Test Setup

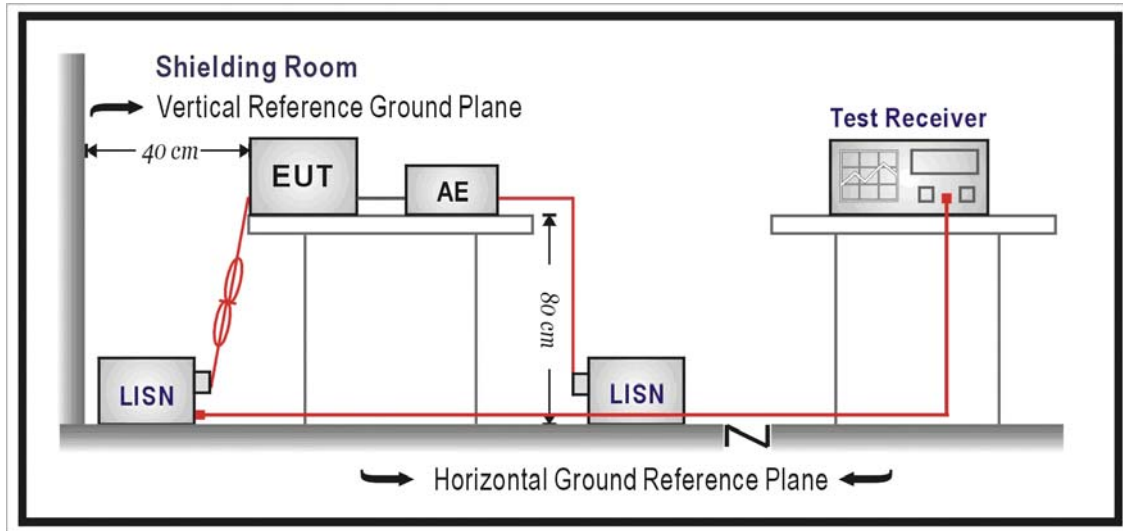

#### 3.3. Limit

Limits		
Frequency (MHz)	QP (dBuV)	AV (dBuV)
0.15 - 0.50	66 - 56	56 - 46
0.50-5.0	56	46
5.0 - 30	60	50

Remarks: In the above table, the tighter limit applies at the band edges.

### 3.4. Test Procedure

The EUT and simulators are connected to the main power through a line impedance stabilization network (L.I.S.N.). This provides a 50 ohm /50uH coupling impedance for the measuring equipment. The peripheral devices are also connected to the main power through a LISN that provides a 50ohm/50uH coupling impedance with 50ohm termination.

(Please refers to the block diagram of the test setup and photographs.)

Both sides of A.C. line are checked for maximum conducted interference. In order to find the maximum emission, the relative positions of equipment and all of the interface cables must be changed on conducted measurement.

Conducted emissions were invested over the frequency range from 0.15MHz to 30MHz using a receiver bandwidth of 9kHz.

### 3.5. Test Result

Site : SR-1	Time : 2007/05/28 - 11:41
Limit : CISPR_B_00M_QP	Margin : 10
EUT : Multi-service Wireless Office Gateway	Probe : LISN-020(L) - Line1
Power : AC 120V/60Hz	Note : MODE 1

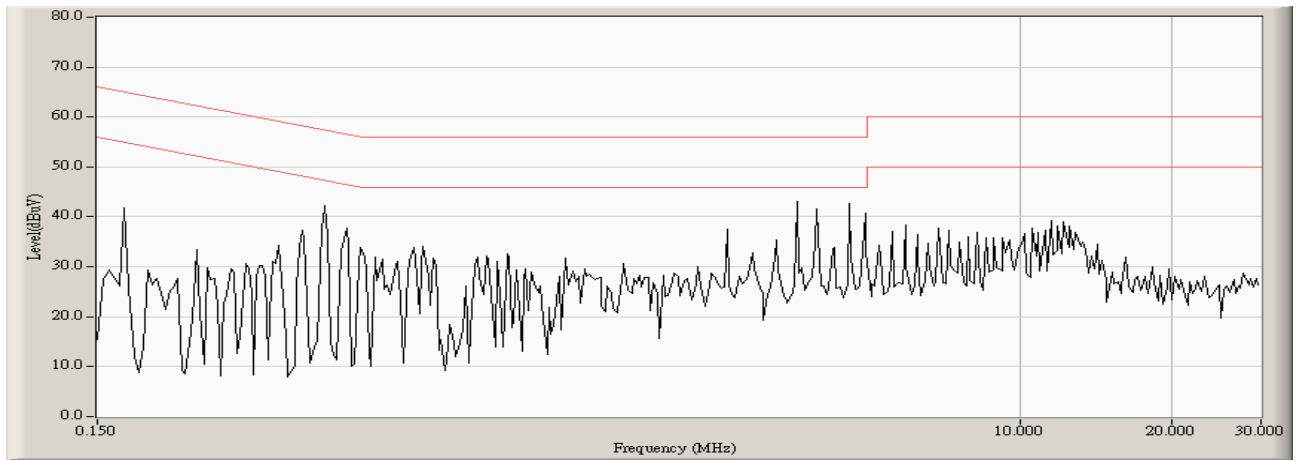



Site : SR-1	Time : 2007/05/28 - 11:44
Limit : CISPR_B_00M_QP	Margin : 0
EUT : Multi-service Wireless Office Gateway	Probe : LISN-020(L) - Line1
Power : AC 120V/60Hz	Note : MODE 1

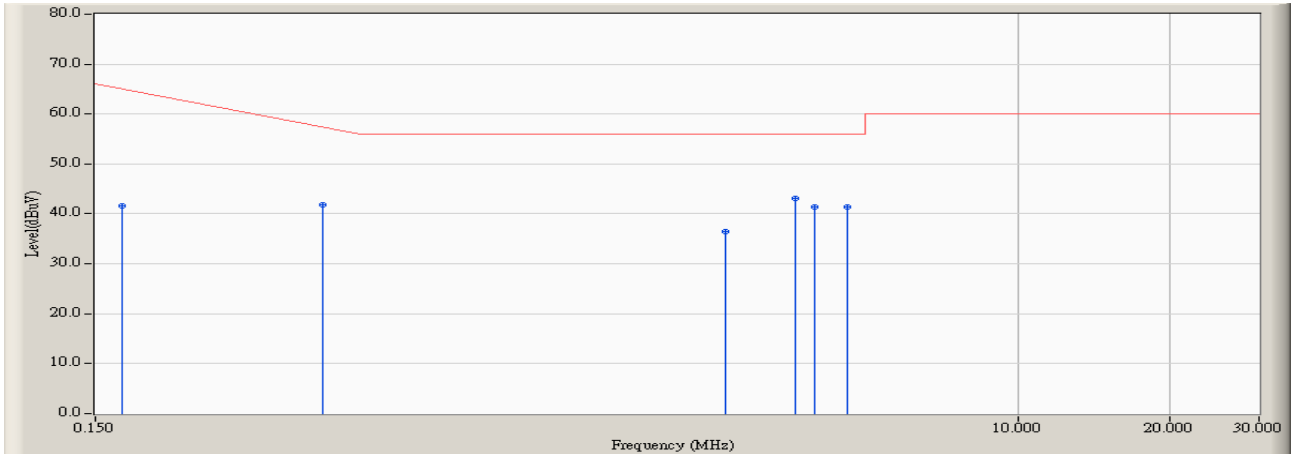

		Frequency (MHz)	Correct Factor (dB)	Reading Level (dBuV)	Measure Level (dBuV)	Margin (dB)	Limit (dBuV)	Detector Type
1		0.170	0.202	41.390	41.592	-23.837	65.429	QUASIPeAK
2		0.423	0.215	41.520	41.735	-16.465	58.200	QUASIPeAK
3		2.635	0.295	36.130	36.425	-19.575	56.000	QUASIPeAK
4	*	3.625	0.338	42.680	43.018	-12.982	56.000	QUASIPeAK
5		3.955	0.352	41.070	41.422	-14.578	56.000	QUASIPeAK
6		4.613	0.381	40.910	41.291	-14.709	56.000	QUASIPeAK

**Note:**

1. All Reading Levels are Quasi-Peak and average value.
2. " \* ", means this data is the worst emission level.
3. Measurement Level = Reading Level + Correct Factor

Site : SR-1	Time : 2007/05/28 - 11:44
Limit : CISPR_B_00M_AV	Margin : 0
EUT : Multi-service Wireless Office Gateway	Probe : LISN-020(L) - Line1
Power : AC 120V/60Hz	Note : MODE 1

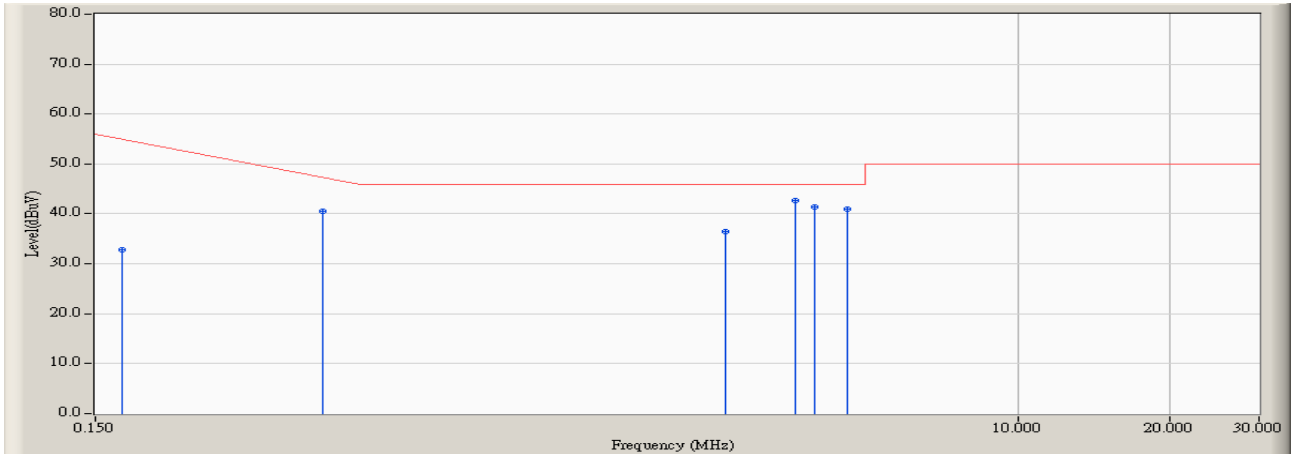

		Frequency (MHz)	Correct Factor (dB)	Reading Level (dBuV)	Measure Level (dBuV)	Margin (dB)	Limit (dBuV)	Detector Type
1		0.170	0.202	32.600	32.802	-22.627	55.429	AVERAGE
2		0.423	0.215	40.260	40.475	-7.725	48.200	AVERAGE
3		2.635	0.295	36.120	36.415	-9.585	46.000	AVERAGE
4	*	3.625	0.338	42.450	42.788	-3.212	46.000	AVERAGE
5		3.955	0.352	41.060	41.412	-4.588	46.000	AVERAGE
6		4.613	0.381	40.530	40.911	-5.089	46.000	AVERAGE

**Note:**

1. All Reading Levels are Quasi-Peak and average value.
2. " \* ", means this data is the worst emission level.
3. Measurement Level = Reading Level + Correct Factor

Site : SR-1	Time : 2007/05/28 - 11:45
Limit : CISPR_B_00M_QP	Margin : 10
EUT : Multi-service Wireless Office Gateway	Probe : LISN-020(N) - Line2
Power : AC 120V/60Hz	Note : MODE 1

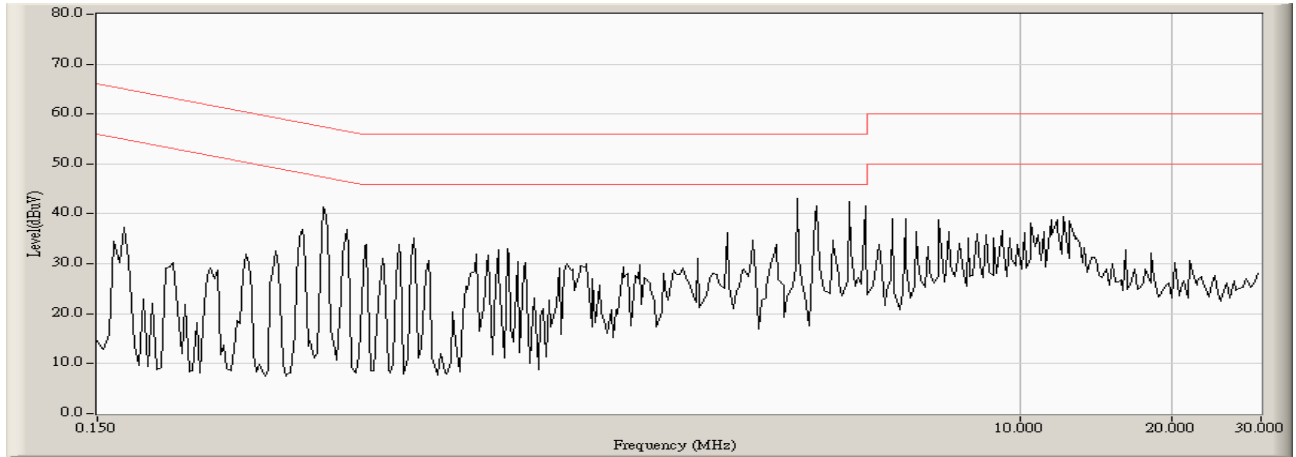

Site : SR-1	Time : 2007/05/28 - 11:47
Limit : CISPR_B_00M_QP	Margin : 0
EUT : Multi-service Wireless Office Gateway	Probe : LISN-020(N) - Line2
Power : AC 120V/60Hz	Note : MODE 1

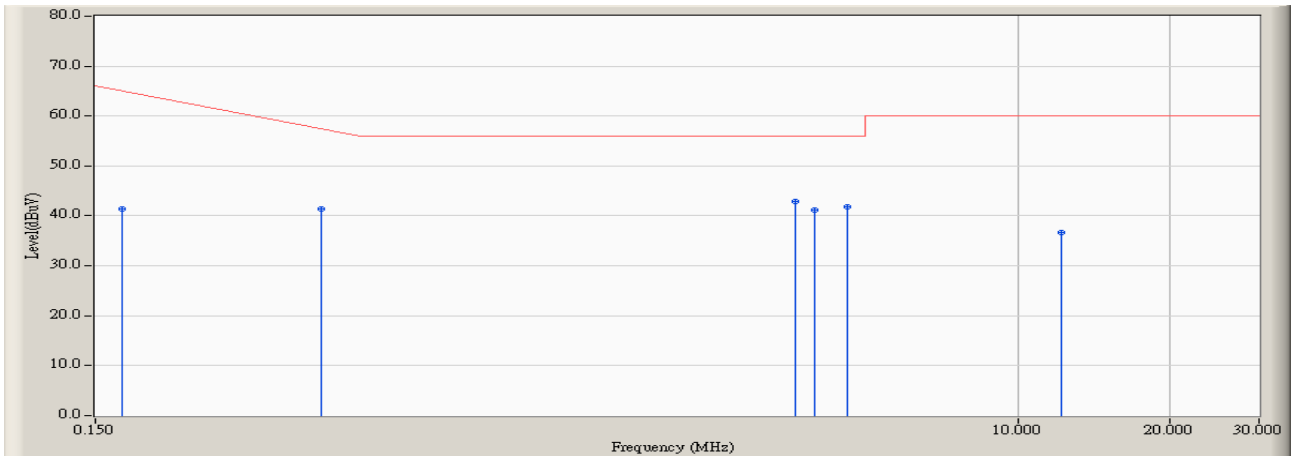

		Frequency (MHz)	Correct Factor (dB)	Reading Level (dBuV)	Measure Level (dBuV)	Margin (dB)	Limit (dBuV)	Detector Type
1		0.170	0.202	41.150	41.352	-24.077	65.429	QUASIPeAK
2		0.420	0.215	41.160	41.375	-16.911	58.286	QUASIPeAK
3	*	3.625	0.338	42.490	42.828	-13.172	56.000	QUASIPeAK
4		3.955	0.352	40.810	41.162	-14.838	56.000	QUASIPeAK
5		4.613	0.371	41.480	41.851	-14.149	56.000	QUASIPeAK
6		12.193	0.652	35.940	36.592	-23.408	60.000	QUASIPeAK

**Note:**

1. All Reading Levels are Quasi-Peak and average value.
2. " \* ", means this data is the worst emission level.
3. Measurement Level = Reading Level + Correct Factor

Site : SR-1	Time : 2007/05/28 - 11:47
Limit : CISPR_B_00M_AV	Margin : 0
EUT : Multi-service Wireless Office Gateway	Probe : LISN-020(N) - Line2
Power : AC 120V/60Hz	Note : MODE 1

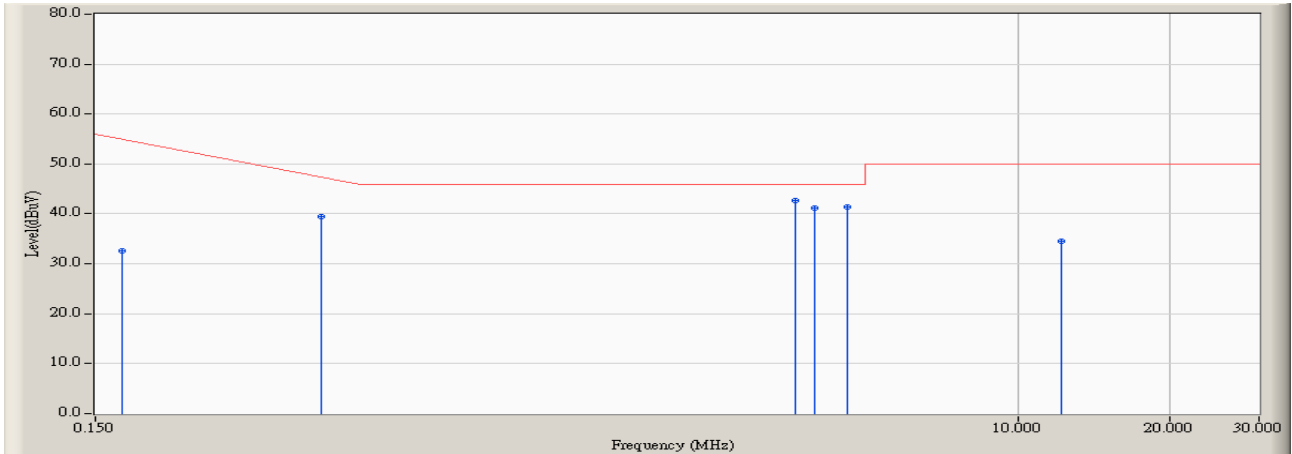

		Frequency (MHz)	Correct Factor (dB)	Reading Level (dBuV)	Measure Level (dBuV)	Margin (dB)	Limit (dBuV)	Detector Type
1		0.170	0.202	32.330	32.532	-22.897	55.429	AVERAGE
2		0.420	0.215	39.330	39.545	-8.741	48.286	AVERAGE
3	*	3.625	0.338	42.250	42.588	-3.412	46.000	AVERAGE
4		3.955	0.352	40.740	41.092	-4.908	46.000	AVERAGE
5		4.613	0.371	40.950	41.321	-4.679	46.000	AVERAGE
6		12.193	0.652	33.980	34.632	-15.368	50.000	AVERAGE

**Note:**

1. All Reading Levels are Quasi-Peak and average value.
2. " \* ", means this data is the worst emission level.
3. Measurement Level = Reading Level + Correct Factor

## 4. Radiated Emission

### 4.1. Test Specification

According to EMC Standard : FCC Part 15 Subpart B, ANSI C63.4

### 4.2. Test Setup

Under 1GHz Test Setup:

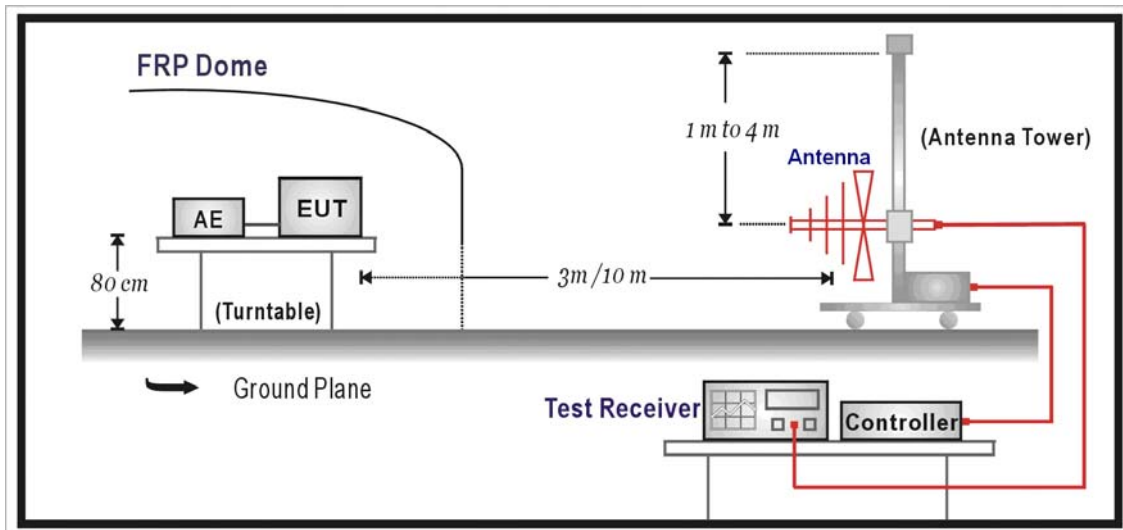

Above 1GHz Test Setup:

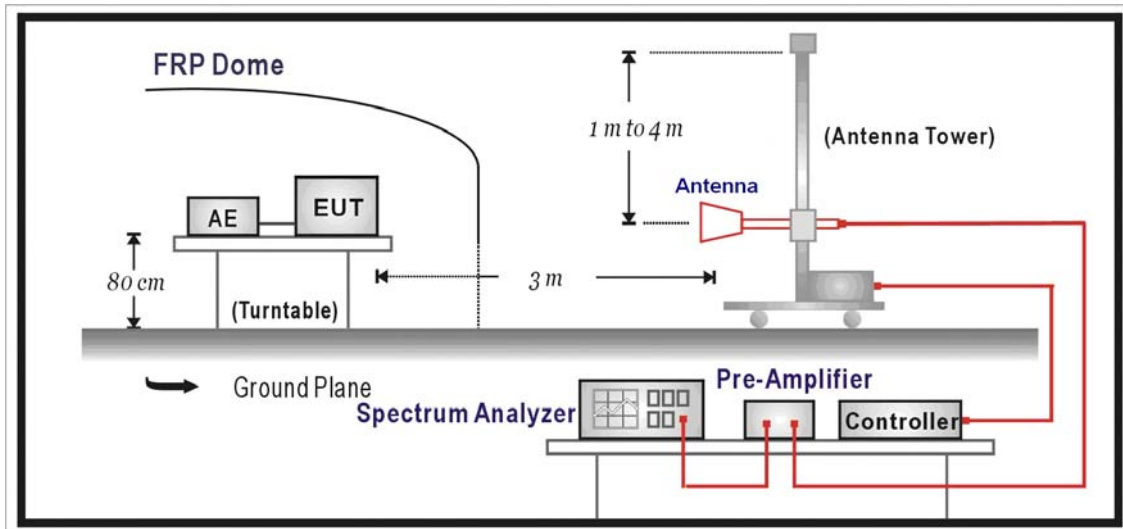

**4.3. Limit**

Under 1GHz test shall not exceed the following value:

Limits		
Frequency (MHz)	Distance (m)	dBuV/m
30 – 230	10	30
230 – 1000	10	37

Remark:

1. The tighter limit shall apply at the edge between two frequency bands.
2. Distance refers to the distance in meters between the measuring instrument antenna and the closed point of any part of the device or system.

Above 1GHz test shall not exceed the following value:

FCC Part 15 Subpart B Paragraph 15.109 Limits (dBuV/m)		
Frequency (MHz)	Distance (m)	dBuV/m
30-88	3	40
88-216	3	43.5
216-960	3	46
Above 960	3	54

Remark:

1. The tighter limit shall apply at the edge between two frequency bands.
2. Distance refers to the distance in meters between the measuring instrument antenna and the closed point of any part of the device or system.
3. RF Voltage (dBuV/m) = 20 log RF Voltage (uV/m)

**4.4. Test Procedure**

The EUT and its simulators are placed on a turn table which is 0.8 meter above ground.

The turn table can rotate 360 degrees to determine the position of the maximum emission level and the antenna can move up and down between 1 meter and 4 meters to find out the maximum emission level.

Both horizontal and vertical polarization of the antenna are set on measurement. In order to find the maximum emission, all of the interface cables must be manipulated on radiated measurement.

For an unintentional radiator, including a digital device, the spectrum shall be investigated from the lowest radio frequency signal generated or used in the device, without going below the lowest frequency for which a radiated emission limit is specified, up to the frequency shown in the following table:

Highest frequency generated or used in the device or on which the device operates or tunes (MHz)	Upper frequency of measurement range (MHz)
Below 1.705	30
1.705 – 108	1000
108 – 500	2000
500 – 1000	5000
Above 1000	5 <sup>th</sup> harmonic of the highest frequency or 40 GHz, whichever is lower

On any frequency or frequencies below or equal to 1000 MHz, the radiated limits shown are based on measuring equipment employing a quasi-peak detector function and above 1000 MHz, the radiated limits shown are based measuring equipment employing an average detector function.

When average radiated emission measurement are included emission measurement Above 1000 MHz, there also is a limit on the radio frequency emissions, as measured using instrumentation with a peak detector function, corresponding to 20 dB above the maximum permitted average limit.

For class A, the measurement distance between the EUT and antenna is 10 meters for under 1GHz and above 1GHz.

For class B, the measurement distance between the EUT and antenna is 10 meters for under 1GHz and 3 meters for above 1GHz.

The bandwidth below 1GHz setting on the field strength meter (R&S Test Receiver ESCS 30) is 120 kHz and above 1GHz is 1MHz.



4.5. Test Result

Site : OATS-3	Time : 2007/05/28 - 17:31
Limit : CISPR_B_10M_QP	Margin : 6
EUT : Multi-service Wireless Office Gateway	Probe : LKANT_S4_2006_01 - HORIZONTAL
Power : AC 120V/60Hz	Note : MODE 1

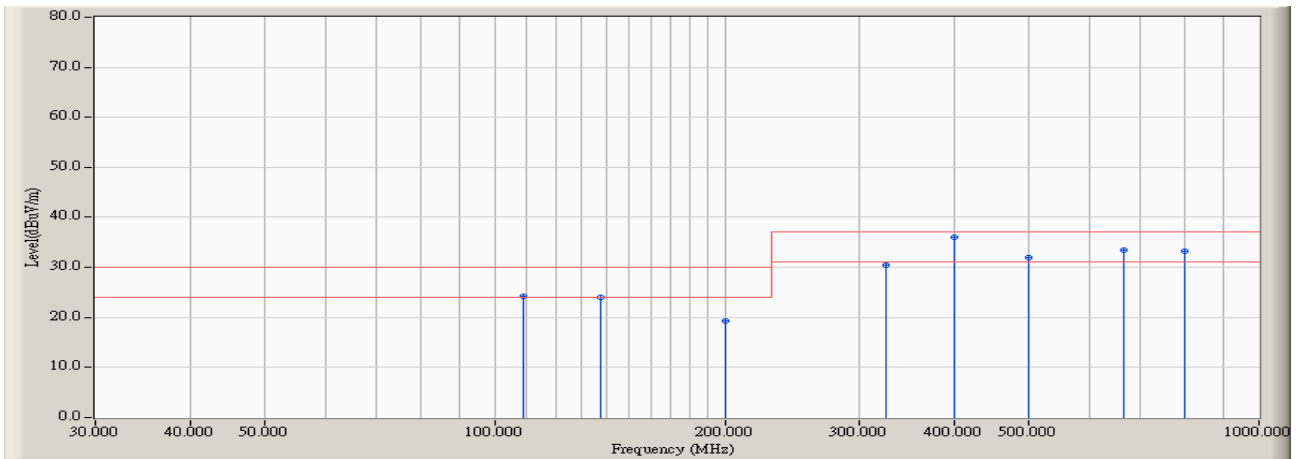

	Frequency (MHz)	Correct Factor (dB)	Reading Level (dBuV)	Measure Level (dBuV/m)	Margin (dB)	Limit (dBuV/m)	Detector Type
1	108.840	13.569	10.600	24.169	-5.831	30.000	QUASPEAK
2	137.500	14.467	9.500	23.967	-6.033	30.000	QUASPEAK
3	200.000	12.536	6.800	19.335	-10.665	30.000	QUASPEAK
4	325.007	18.154	12.300	30.454	-6.546	37.000	QUASPEAK
5	* 399.990	20.249	15.800	36.049	-0.951	37.000	QUASPEAK
6	500.000	22.081	9.800	31.881	-5.119	37.000	QUASPEAK
7	666.653	24.756	8.800	33.557	-3.443	37.000	QUASPEAK
8	799.980	26.376	6.800	33.176	-3.824	37.000	QUASPEAK

Note:

1. All Readings below 1GHz are Quasi-Peak, above are performed with peak and/or average measurements as necessary.
2. " \* ", means this data is the worst emission level.
3. Measurement Level = Reading Level + Correct Factor

Site : OATS-3	Time : 2007/05/28 - 17:01
Limit : CISPR_B_10M_QP	Margin : 6
EUT : Multi-service Wireless Office Gateway	Probe : LKANT_S4_2006_01 - VERTICAL
Power : AC 120V/60Hz	Note : MODE 1

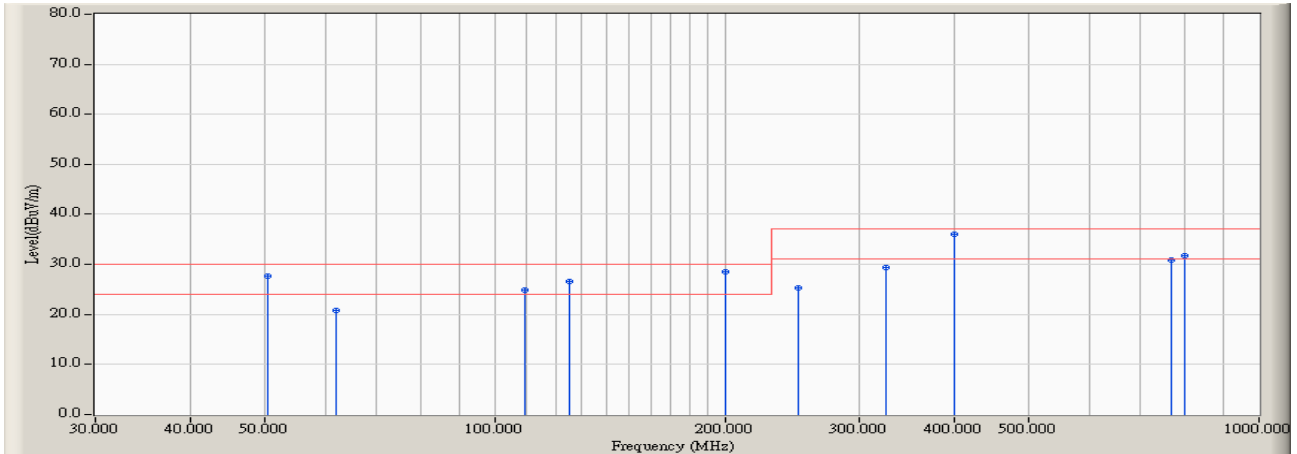

	Frequency (MHz)	Correct Factor (dB)	Reading Level (dBuV)	Measure Level (dBuV/m)	Margin (dB)	Limit (dBuV/m)	Detector Type
1	50.425	10.932	16.800	27.732	-2.268	30.000	QUASPEAK
2	62.000	7.909	12.800	20.709	-9.291	30.000	QUASPEAK
3	109.220	13.553	11.300	24.853	-5.147	30.000	QUASPEAK
4	125.000	14.972	11.600	26.572	-3.428	30.000	QUASPEAK
5	199.993	12.535	16.000	28.535	-1.465	30.000	QUASPEAK
6	250.002	16.088	9.300	25.388	-11.612	37.000	QUASPEAK
7	325.005	18.154	11.200	29.354	-7.646	37.000	QUASPEAK
8	* 399.988	20.249	15.700	35.949	-1.051	37.000	QUASPEAK
9	766.653	25.978	4.800	30.779	-6.221	37.000	QUASPEAK
10	799.980	26.376	5.400	31.776	-5.224	37.000	QUASPEAK

**Note:**

1. All Readings below 1GHz are Quasi-Peak, above are performed with peak and/or average measurements as necessary.
2. " \* ", means this data is the worst emission level.
3. Measurement Level = Reading Level + Correct Factor