

FCC Test Report

Report No.: RF170103D01-1 R1

FCC ID: VZ9160001

Test Model: EAP737

Received Date: Jan. 3, 2017

Test Date: Jan. 4 ~ Feb. 15, 2017

Issued Date: Aug. 3, 2017

Applicant: 4IPNET, INC.

Address: 5F., No.367, Fuxing N. Rd., Songshan Dist., Taipei City 105, Taiwan
(R.O.C.)

Issued By: Bureau Veritas Consumer Products Services (H.K.) Ltd., Taoyuan Branch

Lab Address: No. 47-2, 14th Ling, Chia Pau Vil., Lin Kou Dist., New Taipei City, Taiwan
(R.O.C.)



This report is for your exclusive use. Any copying or replication of this report to or for any other person or entity, or use of our name or trademark, is permitted only with our prior written permission. This report sets forth our findings solely with respect to the test samples identified herein. The results set forth in this report are not indicative or representative of the quality or characteristics of the lot from which a test sample was taken or any similar or identical product unless specifically and expressly noted. Our report includes all of the tests requested by you and the results thereof based upon the information that you provided to us. You have 60 days from date of issuance of this report to notify us of any material error or omission caused by our negligence, provided, however, that such notice shall be in writing and shall specifically address the issue you wish to raise. A failure to raise such issue within the prescribed time shall constitute your unqualified acceptance of the completeness of this report, the tests conducted and the correctness of the report contents. Unless specific mention, the uncertainty of measurement has been explicitly taken into account to declare the compliance or non-compliance to the specification. The report must not be used by the client to claim product certification, approval, or endorsement by TAF or any government agencies.

Table of Contents

Release Control Record	4
1 Certificate of Conformity	5
2 Summary of Test Results	6
2.1 Measurement Uncertainty.....	6
2.2 Modification Record.....	6
3 General Information	7
3.1 General Description of EUT.....	7
3.2 Description of Test Modes.....	9
3.2.1 Test Mode Applicability and Tested Channel Detail.....	10
3.3 Duty Cycle of Test Signal.....	12
3.4 Description of Support Units.....	13
3.4.1 Configuration of System under Test.....	13
3.5 General Description of Applied Standard.....	14
4 Test Types and Results	15
4.1 Radiated Emission and Bandedge Measurement.....	15
4.1.1 Limits of Radiated Emission and Bandedge Measurement.....	15
4.1.2 Test Instruments.....	16
4.1.3 Test Procedure.....	17
4.1.4 Deviation from Test Standard.....	17
4.1.5 Test Setup.....	18
4.1.6 EUT Operating Condition.....	19
4.1.7 Test Results.....	20
4.2 Conducted Emission Measurement.....	39
4.2.1 Limits of Conducted Emission Measurement.....	39
4.2.2 Test Instruments.....	39
4.2.3 Test Procedure.....	40
4.2.4 Deviation from Test Standard.....	40
4.2.5 Test Setup.....	40
4.2.6 EUT Operating Condition.....	40
4.2.7 Test Results.....	41
4.3 Transmit Power Measurement.....	45
4.3.1 Limits of Transmit Power Measurement.....	45
4.3.2 Test Setup.....	46
4.3.3 Test Instruments.....	46
4.3.4 Test Procedure.....	46
4.3.5 Deviation from Test Standard.....	46
4.3.6 EUT Operating Condition.....	46
4.3.7 Test Result.....	47
4.4 Occupied Bandwidth Measurement.....	49
4.4.1 Test Setup.....	49
4.4.2 Test Instruments.....	49
4.4.3 Test Procedure.....	49
4.4.4 Test Results.....	50
4.5 Peak Power Spectral Density Measurement.....	52
4.5.1 Limits of Peak Power Spectral Density Measurement.....	52
4.5.2 Test Setup.....	52
4.5.3 Test Instruments.....	52
4.5.4 Test Procedure.....	52
4.5.5 Deviation from Test Standard.....	52
4.5.6 EUT Operating Condition.....	52
4.5.7 Test Results.....	53
4.6 Frequency Stability Measurement.....	59

4.6.1	Limits of Frequency Stability Measurement	59
4.6.2	Test Setup	59
4.6.3	Test Instruments	59
4.6.4	Test Procedure	59
4.6.5	Deviation from Test Standard	59
4.6.6	EUT Operating Condition	59
4.6.7	Test Results	60
4.7	6dB Bandwidth Measurement	61
4.7.1	Limits of 6dB Bandwidth Measurement	61
4.7.2	Test Setup	61
4.7.3	Test Instruments	61
4.7.4	Test Procedure	61
4.7.5	Deviation from Test Standard	61
4.7.6	EUT Operating Condition	61
4.7.7	Test Results	62
5	Pictures of Test Arrangements	64
	Annex A- Radiated Out of Band Emission (OOBE) Measurement (For U-NII-3 band)	65
	Appendix – Information on the Testing Laboratories	68

Release Control Record

Issue No.	Description	Date Issued
RF170103D01-1	Original release.	Feb. 17, 2017
RF170103D01-1 R1	Modify address of applicant.	Aug. 3, 2017

1 Certificate of Conformity

Product: Enterprise Access Point

Brand: 4ipnet

Test Model: EAP737

Sample Status: Engineering sample

Applicant: 4IPNET, INC.

Test Date: Jan. 4 ~ Feb. 15, 2017

Standard: 47 CFR FCC Part 15, Subpart E (Section 15.407)
ANSI C63.10: 2013

The above equipment has been tested by **Bureau Veritas Consumer Products Services (H.K.) Ltd., Taoyuan Branch**, and found compliance with the requirement of the above standards. The test record, data evaluation & Equipment Under Test (EUT) configurations represented herein are true and accurate accounts of the measurements of the sample's EMC characteristics under the conditions specified in this report.

Prepared by :



Celia Chen / Supervisor

Date:

Aug. 3, 2017

Approved by :



Rex Lai / Assistant Manager

Date:

Aug. 3, 2017

2 Summary of Test Results

47 CFR FCC Part 15, Subpart E (Section 15.407)			
FCC Clause	Test Item	Result	Remarks
15.407(b)(6)	AC Power Conducted Emissions	Pass	Meet the requirement of limit. Minimum passing margin is -12.49dB at 0.25547MHz.
15.407(b)(1/2/3/4(i/ii)/6)	Radiated Emissions & Band Edge Measurement*	Pass	Meet the requirement of limit. Minimum passing margin is -1.02dB at 5150.00MHz.
15.407(a)(1/2/3)	Max Average Transmit Power	Pass	Meet the requirement of limit.
---	Occupied Bandwidth Measurement	-	Reference only.
15.407(a)(1/2/3)	Peak Power Spectral Density	Pass	Meet the requirement of limit.
15.407(e)	6dB bandwidth	Pass	Meet the requirement of limit. (U-NII-3 Band only)
15.407(g)	Frequency Stability	Pass	Meet the requirement of limit.
15.203	Antenna Requirement	Pass	Antenna connector is I-PEX not a standard connector.

*For U-NII-3 band compliance with rule part 15.407(b)(4)(i), the OBE test plots were recorded in Annex A.

2.1 Measurement Uncertainty

Where relevant, the following measurement uncertainty levels have been estimated for tests performed on the EUT as specified in CISPR 16-4-2:

Measurement	Frequency	Expanded Uncertainty (k=2) (±)
Conducted Emissions at mains ports	150kHz ~ 30MHz	2.77 dB
Radiated Emissions up to 1 GHz	9kHz ~ 30MHz	2.38 dB
	30MHz ~ 1000MHz	5.54 dB
Radiated Emissions above 1 GHz	1GHz ~ 6GHz	4.77 dB
	6GHz ~ 18GHz	5.48 dB

2.2 Modification Record

There were no modifications required for compliance.

3 General Information

3.1 General Description of EUT

Product	Enterprise Access Point
Brand	4ipnet
Test Model	EAP737
Status of EUT	Engineering sample
Power Supply Rating	12Vdc from adapter or 56Vdc from PoE
Modulation Type	64QAM, 16QAM, QPSK, BPSK 256QAM for OFDM in 11ac mode only.
Modulation Technology	OFDM
Transfer Rate	802.11a: 54/48/36/24/18/12/9/6Mbps 802.11n: up to 300Mbps 802.11ac: up to 867Mbps
Operating Frequency	5180 ~ 5240MHz 5745 ~ 5825MHz
Number of Channel	5180 ~ 5240MHz 4 for 802.11a, 802.11n (20MHz), 802.11ac (20MHz) 2 for 802.11n (40MHz), 802.11ac (40MHz) 1 for 802.11ac (80MHz) 5745 ~ 5825MHz 5 for 802.11a, 802.11n (20MHz) 802.11ac (20MHz) 2 for 802.11n (40MHz) 802.11ac (40MHz) 1 for 802.11ac (80MHz)
Output Power	5180 ~ 5240MHz: 691.369mW 5745 ~ 5825MHz: 554.233mW
Antenna Type	CDD MODE PIFA antenna with 1.38dBi gain Beamforming MODE PIFA antenna with 3.27dBi gain
Antenna Connector	I-PEX
Accessory Device	Adapter
Data Cable Supplied	N/A

Note:

- The EUT incorporates a MIMO function. Physically, the EUT provides two completed transmitters and two receivers.

Modulation Mode	TX FUNCTION
802.11a	2TX
802.11n (20MHz)	2TX
802.11n (40MHz)	2TX
802.11ac (20MHz)	2TX
802.11ac (40MHz)	2TX
802.11ac (80MHz)	2TX

* The modulation and bandwidth are similar for 802.11n mode for 20MHz / 40MHz and 802.11ac mode for 20MHz / 40MHz, therefore investigated worst case to representative mode in test report. (Final test mode refer section 3.2.1)

2. The EUT uses following adapter.

Brand	APD
Model	WB-18D12R
Input Power	100-240Vac, 0.5A, 50-60Hz (AC 2 Pin)
Output Power	12Vdc, 1.5A
Power Line	Non-shielded DC cable (1.5m)

3. The above EUT information is declared by manufacturer and for more detailed features description, please refer to the manufacturer's specifications or user's manual.

3.2 Description of Test Modes

FOR 5180 ~ 5240MHz

4 channels are provided for 802.11a, 802.11n (20MHz), 802.11ac (20MHz):

Channel	Frequency	Channel	Frequency
36	5180 MHz	44	5220 MHz
40	5200 MHz	48	5240 MHz

2 channels are provided for 802.11n (40MHz), 802.11ac (40MHz):

Channel	Frequency	Channel	Frequency
38	5190 MHz	46	5230 MHz

1 channel is provided for 802.11ac (80MHz):

Channel	Frequency
42	5210MHz

FOR 5745 ~ 5825MHz:

5 channels are provided for 802.11a, 802.11n (20MHz), 802.11ac (20MHz):

Channel	Frequency	Channel	Frequency
149	5745MHz	161	5805MHz
153	5765MHz	165	5825MHz
157	5785MHz		

2 channels are provided for 802.11n (40MHz), 802.11ac (40MHz):

Channel	Frequency	Channel	Frequency
151	5755MHz	159	5795MHz

1 channel is provided for 802.11ac (80MHz):

Channel	Frequency
155	5775MHz

3.2.1 Test Mode Applicability and Tested Channel Detail

EUT Configure Mode	Applicable To				Description
	RE ³ 1G	RE<1G	PLC	APCM	
A	√	√	√	√	EUT powered from adapter
B	-	√	√	-	EUT powered from PoE

Where **RE³1G**: Radiated Emission above 1GHz **RE<1G**: Radiated Emission below 1GHz
PLC: Power Line Conducted Emission **APCM**: Antenna Port Conducted Measurement

NOTE: 1. The EUT had been pre-tested on the positioned of each 3 axis. The worst case was found when positioned on **Y-plane**.
 2. "-" means no effect.

Radiated Emission Test (Above 1GHz):

- Pre-Scan has been conducted to determine the worst-case mode from all possible combinations between available modulations, data rates and antenna ports (if EUT with antenna diversity architecture).
- Following channel(s) was (were) selected for the final test as listed below.

CDD Mode							
EUT Configure Mode	Mode	FREQ. Band (MHz)	Available Channel	Tested Channel	Modulation Technology	Modulation Type	Data Rate (Mbps)
A	802.11a	5180-5240	36 to 48	36, 40, 48	OFDM	BPSK	6
A	802.11n (20MHz)		36 to 48	36, 40, 48	OFDM	BPSK	6.5
A	802.11n (40MHz)		38 to 46	38, 46	OFDM	BPSK	13.5
A	802.11ac (80MHz)		42	42	OFDM	BPSK	29.3
A	802.11a	5745-5825	149 to 165	149, 157, 165	OFDM	BPSK	6
A	802.11n (20MHz)		149 to 165	149, 157, 165	OFDM	BPSK	6.5
A	802.11n (40MHz)		151 to 159	151, 159	OFDM	BPSK	13.5
A	802.11ac (80MHz)		155	155	OFDM	BPSK	29.3

Radiated Emission Test (Below 1GHz):

- Pre-Scan has been conducted to determine the worst-case mode from all possible combinations between available modulations, data rates and antenna ports (if EUT with antenna diversity architecture).
- Following channel(s) was (were) selected for the final test as listed below.

CDD Mode							
EUT Configure Mode	Mode	FREQ. Band (MHz)	Available Channel	Tested Channel	Modulation Technology	Modulation Type	Data Rate (Mbps)
A	802.11n (20MHz)	5180-5240	36 to 48	40	OFDM	BPSK	6
		5745-5825	149 to 165		OFDM	BPSK	6

Power Line Conducted Emission Test:

- Pre-Scan has been conducted to determine the worst-case mode from all possible combinations between available modulations, data rates and antenna ports (if EUT with antenna diversity architecture).
- Following channel(s) was (were) selected for the final test as listed below.

CDD Mode							
EUT Configure Mode	Mode	FREQ. Band (MHz)	Available Channel	Tested Channel	Modulation Technology	Modulation Type	Data Rate (Mbps)
A	802.11n (20MHz)	5180-5240	36 to 48	40	OFDM	BPSK	6
		5745-5825	149 to 165		OFDM	BPSK	6
B	802.11n (20MHz)	5180-5240	36 to 48	40	OFDM	BPSK	6
		5745-5825	149 to 165		OFDM	BPSK	6

Antenna Port Conducted Measurement:

- This item includes all test value of each mode, but only includes spectrum plot of worst value of each mode.
- Pre-Scan has been conducted to determine the worst-case mode from all possible combinations between available modulations, data rates and antenna ports (if EUT with antenna diversity architecture).
- Following channel(s) was (were) selected for the final test as listed below.

CDD Mode							
EUT Configure Mode	Mode	FREQ. Band (MHz)	Available Channel	Tested Channel	Modulation Technology	Modulation Type	Data Rate (Mbps)
A	802.11a	5180-5240	36 to 48	36, 40, 48	OFDM	BPSK	6
A	802.11n (20MHz)		36 to 48	36, 40, 48	OFDM	BPSK	6.5
A	802.11n (40MHz)		38 to 46	38, 46	OFDM	BPSK	13.5
A	802.11ac (80MHz)		42	42	OFDM	BPSK	29.3
A	802.11a	5745-5825	149 to 165	149, 157, 165	OFDM	BPSK	6
A	802.11n (20MHz)		149 to 165	149, 157, 165	OFDM	BPSK	6.5
A	802.11n (40MHz)		151 to 159	151, 159	OFDM	BPSK	13.5
A	802.11ac (80MHz)		155	155	OFDM	BPSK	29.3

Beamforming_NSS1 MODE							
EUT Configure Mode	Mode	FREQ. Band (MHz)	Available Channel	Tested Channel	Modulation Technology	Modulation Type	Data Rate (Mbps)
A	802.11ac (20MHz)	5180-5240	36 to 48	36, 40, 48	OFDM	BPSK	6.5
A	802.11ac (40MHz)		38 to 46	38, 46	OFDM	BPSK	13.5
A	802.11ac (80MHz)		42	42	OFDM	BPSK	29.3
A	802.11ac (20MHz)	5745-5825	149 to 165	149, 157, 165	OFDM	BPSK	6.5
A	802.11ac (40MHz)		151 to 159	151, 159	OFDM	BPSK	13.5
A	802.11ac (80MHz)		155	155	OFDM	BPSK	29.3

Test Condition:

APPLICABLE TO	EUT CONFIGURE MODE	ENVIRONMENTAL CONDITIONS	INPUT POWER	TESTED BY
RE ³ 1G	A	26deg. C, 76%RH	120Vac, 60Hz (Adapter)	Ian Chang
RE<1G	A	21deg. C, 71%RH	120Vac, 60Hz (Adapter)	Aaron You
PLC	A	21deg. C, 61%RH	120Vac, 60Hz (Adapter)	Aaron You
	B	21deg. C, 61%RH	120Vac, 60Hz (PoE)	Aaron You
APCM	A	25deg. C, 76%RH	120Vac, 60Hz (Adapter)	Saxon Lee

3.3 Duty Cycle of Test Signal

Duty cycle of test signal is < 98 %, duty factor is required

802.11a: Duty cycle = 1.956/2.087 = 0.937, Duty factor = $10 * \log(1/0.937) = 0.28$

802.11n (20MHz): Duty cycle = 4.884/5.043 = 0.968, Duty factor = $10 * \log(1/0.968) = 0.14$

802.11n (40MHz): Duty cycle = 2.362/2.492 = 0.948, Duty factor = $10 * \log(1/0.948) = 0.23$

802.11ac (80MHz): Duty cycle = 1.101/1.21 = 0.91, Duty factor = $10 * \log(1/0.91) = 0.41$

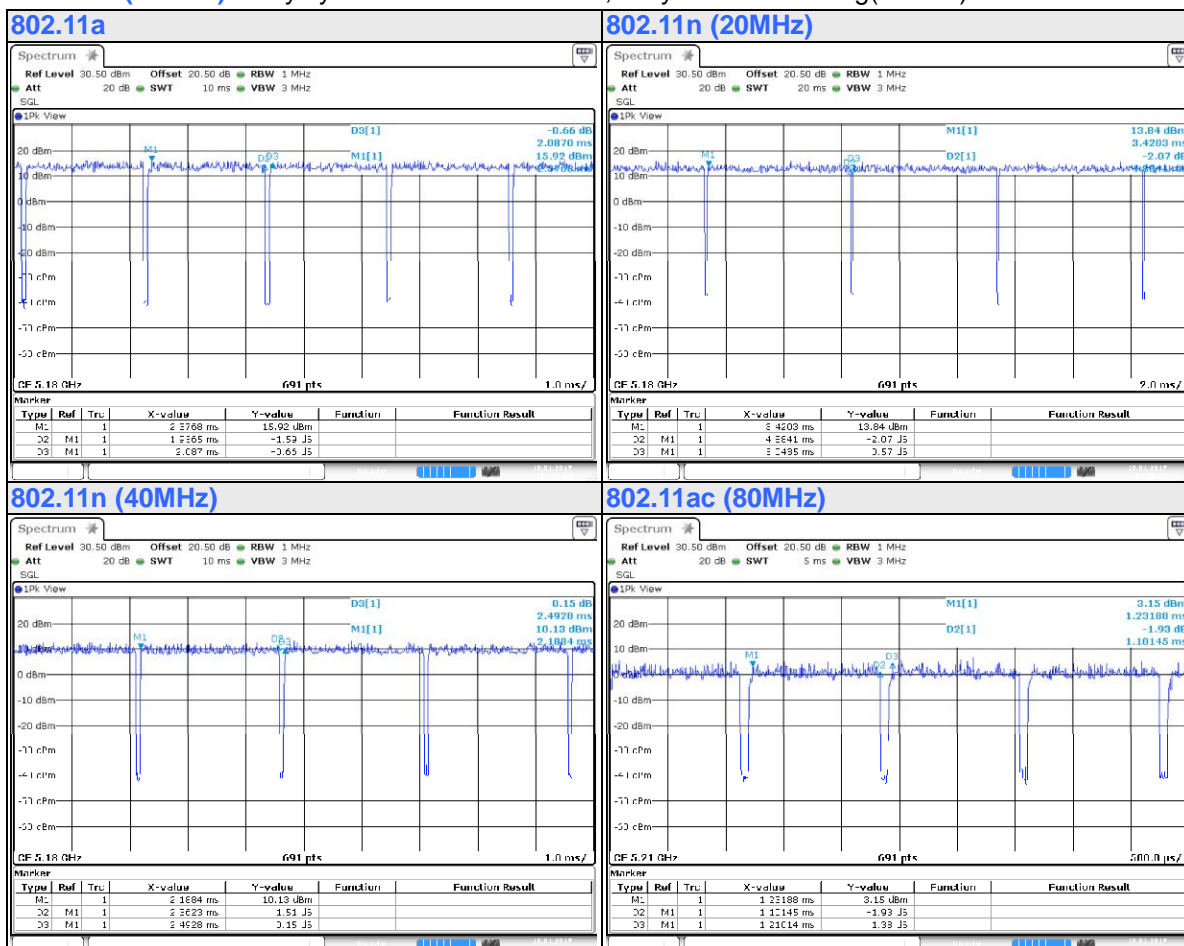

3.4 Description of Support Units

The EUT has been tested as an independent unit together with other necessary accessories or support units. The following support units or accessories were used to form a representative test configuration during the tests.

ID	Product	Brand	Model No.	Serial No.	FCC ID	Remarks
A.	LAN Load	N/A	N/A	N/A	N/A	Provided by Lab
B.	USB 3.0 Flash Drive	HP	v250w	N/A	FCC DoC Approved	Provided by Lab
C.	Notebook	DELL	E5410	BW33YM1	FCC DoC Approved	Provided by Lab
D.	PoE Adapter	PHIHONG	POE31U-1AT	N/A	N/A	Supplied by client

Note:

1. All power cords of the above support units are non-shielded (1.8m).
2. Item C acted as communication partners to transfer data.

ID	Descriptions	Qty.	Length (m)	Shielding (Yes/No)	Cores (Qty.)	Remarks
1.	LAN cable	2	1.5	N	0	Provided by Lab
2.	LAN cable	1	10	N	0	Provided by Lab
3.	DC cable	1	1.5	N	0	Supplied by client
4.	LAN cable	1	1.5	N	0	Supplied by client

Note: The core(s) is(are) originally attached to the cable(s).

3.4.1 Configuration of System under Test

TEST CONFIGURATION – Mode A

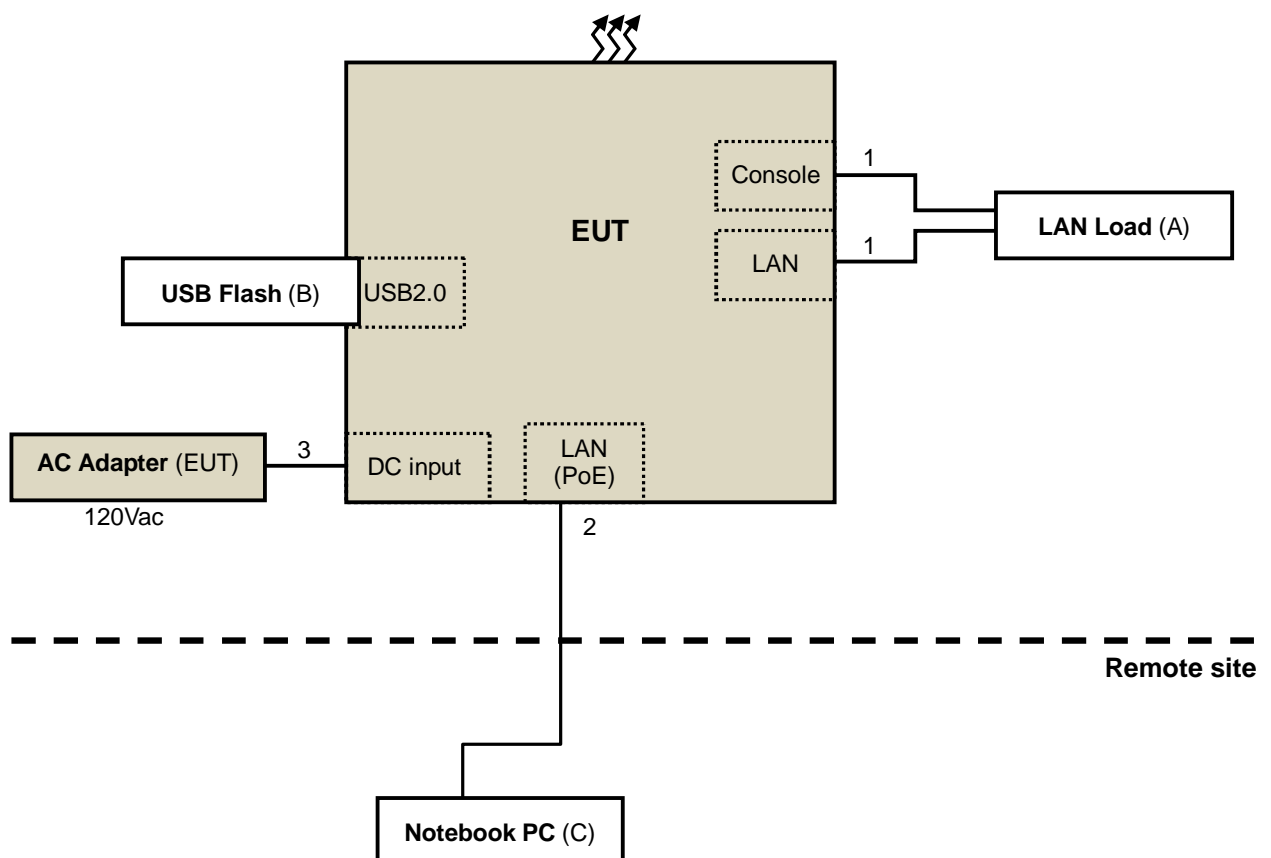

TEST CONFIGURATION – Mode B

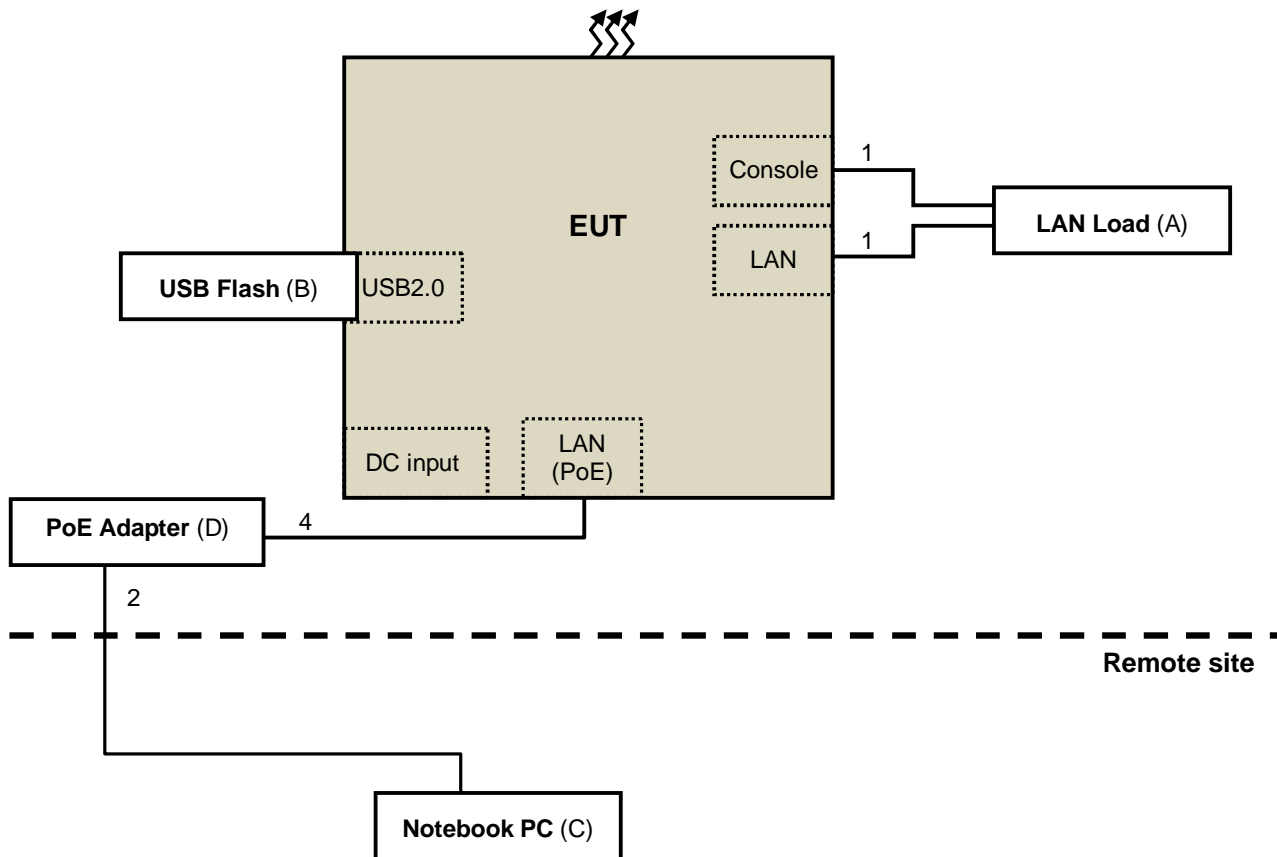

3.5 General Description of Applied Standard

The EUT is a RF Product. According to the specifications of the manufacturer, it must comply with the requirements of the following standards:

FCC Part 15, Subpart E (15.407)
KDB 789033 D02 General UNII Test Procedure New Rules v01r03
KDB 662911 D01 Multiple Transmitter Output v02r01
ANSI C63.10-2013

All test items have been performed and recorded as per the above standards.

NOTE: The EUT has been verified to comply with the requirements of FCC Part 15, Subpart B, Class B (DoC). The test report has been issued separately.

4 Test Types and Results

4.1 Radiated Emission and Bandedge Measurement

4.1.1 Limits of Radiated Emission and Bandedge Measurement

Radiated emissions which fall in the restricted bands must comply with the radiated emission limits specified as below table.

Frequencies (MHz)	Field Strength (microvolts/meter)	Measurement Distance (meters)
0.009 ~ 0.490	2400/F(kHz)	300
0.490 ~ 1.705	24000/F(kHz)	30
1.705 ~ 30.0	30	30
30 ~ 88	100	3
88 ~ 216	150	3
216 ~ 960	200	3
Above 960	500	3

NOTE:

- The lower limit shall apply at the transition frequencies.
- Emission level (dBuV/m) = 20 log Emission level (uV/m).
- For frequencies above 1000MHz, the field strength limits are based on average detector, however, the peak field strength of any emission shall not exceed the maximum permitted average limits, specified above by more than 30dB under any condition of modulation.

Limits of unwanted emission out of the restricted bands

Applicable To		Limit	
789033 D02 General UNII Test Procedure New Rules v01r03		Field Strength at 3m	
		PK:74 (dBuV/m)	AV:54 (dBuV/m)
Frequency Band	Applicable To	EIRP Limit	Equivalent Field Strength at 3m
5150~5250 MHz	15.407(b)(1)	PK:-27 (dBm/MHz)	PK:68.2(dBuV/m)
5250~5350 MHz	15.407(b)(2)		
5470~5725 MHz	15.407(b)(3)		
5725~5850 MHz	<input checked="" type="checkbox"/> 15.407(b)(4)(i)	PK:-27 (dBm/MHz) ^{*1} PK:10 (dBm/MHz) ^{*2} PK:15.6 (dBm/MHz) ^{*3} PK:27 (dBm/MHz) ^{*4}	PK: 68.2(dBuV/m) ^{*1} PK:105.2 (dBuV/m) ^{*2} PK: 110.8(dBuV/m) ^{*3} PK:122.2 (dBuV/m) ^{*4}
	<input type="checkbox"/> 15.407(b)(4)(ii)	Emission limits in section 15.247(d)	
^{*1} beyond 75 MHz or more above of the band edge. ^{*3} below the band edge increasing linearly to a level of 15.6 dBm/MHz at 5 MHz above.		^{*2} below the band edge increasing linearly to 10 dBm/MHz at 25 MHz above. ^{*4} from 5 MHz above or below the band edge increasing linearly to a level of 27 dBm/MHz at the band edge.	

Note:

The following formula is used to convert the equipment isotropic radiated power (eirp) to field strength:

$$E = \frac{1000000\sqrt{30P}}{3} \mu\text{V/m, where P is the eirp (Watts).}$$

4.1.2 Test Instruments

DESCRIPTION & MANUFACTURER	MODEL NO.	SERIAL NO.	CALIBRATED DATE	CALIBRATED UNTIL
HP Preamplifier	8447D	2432A03504	Feb. 26, 2016	Feb. 25, 2017
HP Preamplifier	8449B	3008A01201	Feb. 26, 2016	Feb. 25, 2017
MITEQ Preamplifier	AMF-6F-260400-33-8P	892164	Mar. 01, 2016	Feb. 28, 2017
Agilent TEST RECEIVER	N9038A	MY50010158	Aug. 04, 2016	Aug. 03, 2017
Schwarzbeck Antenna	VULB 9168	139	Dec. 13, 2016	Dec. 12, 2017
Schwarzbeck Antenna	VHBA 9123	480	May 29, 2015	May 28, 2017
Schwarzbeck Horn Antenna	BBHA-9170	212	Dec. 30, 2016	Dec. 29, 2017
Schwarzbeck Horn Antenna	BBHA 9120-D1	D130	Dec. 27, 2016	Dec. 26, 2017
ADT. Turn Table	TT100	0306	NA	NA
ADT. Tower	AT100	0306	NA	NA
Software	Radiated_V7.6.15.9.5	NA	NA	NA
SUHNER RF cable With 4dB PAD	SF104	CABLE-CH6	Aug. 15, 2016	Aug. 14, 2017
SUHNER RF cable With 3dB PAD	SF102	Cable-CH8-3.6m	Aug. 15, 2016	Aug. 14, 2017
KEYSIGHT MIMO Powermeasurement Test set	U2021XA	U2021XA-001	May 25, 2016	May 24, 2017
KEYSIGHT Spectrum Analyzer	N9030A	MY54490260	Jul. 26, 2016	Jul. 25, 2017
Loop Antenna EMCI	LPA600	270	Aug. 20, 2015	Aug. 19, 2017
EMCO Horn Antenna	3115	00028257	Dec. 15, 2016	Dec. 14, 2017
Highpass filter Wainwright Instruments	WHK 3.1/18G-10SS	SN 8	NA	NA
ROHDE & SCHWARZ Spectrum Analyzer	FSV40	101042	Sep. 30, 2016	Sep. 29, 2017
Anritsu Power Sensor	MA2411B	0738404	Apr. 28, 2016	Apr. 27, 2017
Anritsu Power Meter	ML2495A	0842014	Apr. 28, 2016	Apr. 27, 2017
Temperature & Humidity Chamber	MHU-225AU	920409	May 25, 2016	May 24, 2017
DIGITAL POWER METER IDRC	CP-240	240515	Sep. 9, 2016	Sep. 8, 2017
AC Power Source ExTech	CFW-105	E000603	NA	NA

- NOTE:**
1. The calibration interval of the above test instruments is 12/24 months. And the calibrations are traceable to NML/ROC and NIST/USA.
 2. The horn antenna and HP preamplifier (model: 8449B) are used only for the measurement of emission frequency above 1GHz if tested.
 3. The test was performed in Chamber No. 6.
 4. The Industry Canada Reference No. IC 7450E-6.
 5. The FCC Site Registration No. is 447212.

4.1.3 Test Procedure

For Radiated emission below 30MHz

- a. The EUT was placed on the top of a rotating table 0.8 meters above the ground at a 3 meter chamber room. The table was rotated 360 degrees to determine the position of the highest radiation.
- b. The EUT was set 3 meters away from the interference-receiving antenna, which was mounted on the top of a variable-height antenna tower.
- c. Both X and Y axes of the antenna are set to make the measurement.
- d. For each suspected emission, the EUT was arranged to its worst case and the rotatable table was turned from 0 degrees to 360 degrees to find the maximum reading.
- e. The test-receiver system was set to Quasi-Peak Detect Function and Specified Bandwidth with Maximum Hold Mode.

NOTE: The resolution bandwidth and video bandwidth of test receiver/spectrum analyzer is 9kHz at frequency below 30MHz.

For Radiated emission above 30MHz

- a. The EUT was placed on the top of a rotating table 0.8 meters (for 30MHz ~ 1GHz) / 1.5 meters (for above 1GHz) above the ground at 3 meter chamber room for test. The table was rotated 360 degrees to determine the position of the highest radiation.
- b. The EUT was set 3 meters away from the interference-receiving antenna, which was mounted on the top of a variable-height antenna tower.
- c. The height of antenna is varied from one meter to four meters above the ground to determine the maximum value of the field strength. Both horizontal and vertical polarizations of the antenna are set to make the measurement.
- d. For each suspected emission, the EUT was arranged to its worst case and then the antenna was tuned to heights from 1 meter to 4 meters and the rotatable table was turned from 0 degrees to 360 degrees to find the maximum reading.
- e. The test-receiver system was set to quasi-peak detect function and specified bandwidth with maximum hold mode when the test frequency is below 1 GHz.
- f. The test-receiver system was set to peak and average detect function and specified bandwidth with maximum hold mode when the test frequency is above 1 GHz. If the peak reading value also meets average limit, measurement with the average detector is unnecessary.

Note:

1. The resolution bandwidth and video bandwidth of test receiver/spectrum analyzer is 120kHz for Quasi-peak detection (QP) at frequency below 1GHz.
2. The resolution bandwidth of test receiver/spectrum analyzer is 1 MHz and the video bandwidth is 3 MHz for Peak detection (PK) at frequency above 1GHz.
3. The resolution bandwidth of test receiver/spectrum analyzer is 1MHz and the video bandwidth is $\geq 1/T$ (Duty cycle < 98%) or 10Hz (Duty cycle $\geq 98\%$) for Average detection (AV) at frequency above 1GHz.
4. All modes of operation were investigated and the worst-case emissions are reported.

4.1.4 Deviation from Test Standard

No deviation.

4.1.5 Test Setup

For Radiated emission below 30MHz

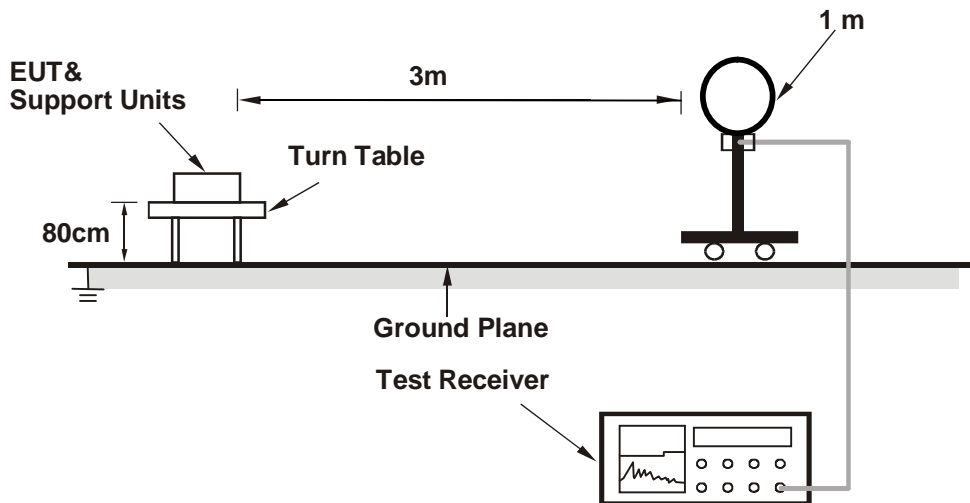

For Radiated emission 30MHz to 1GHz

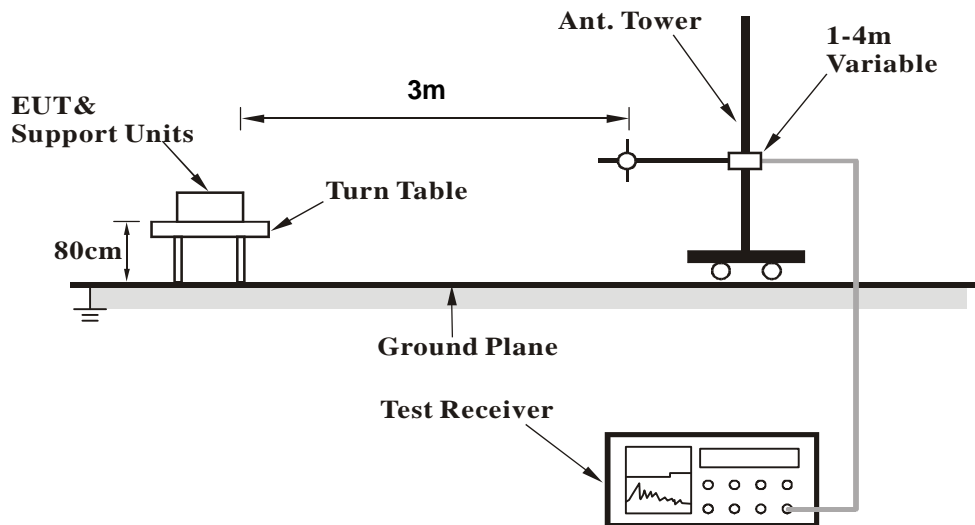

For Radiated emission above 1GHz

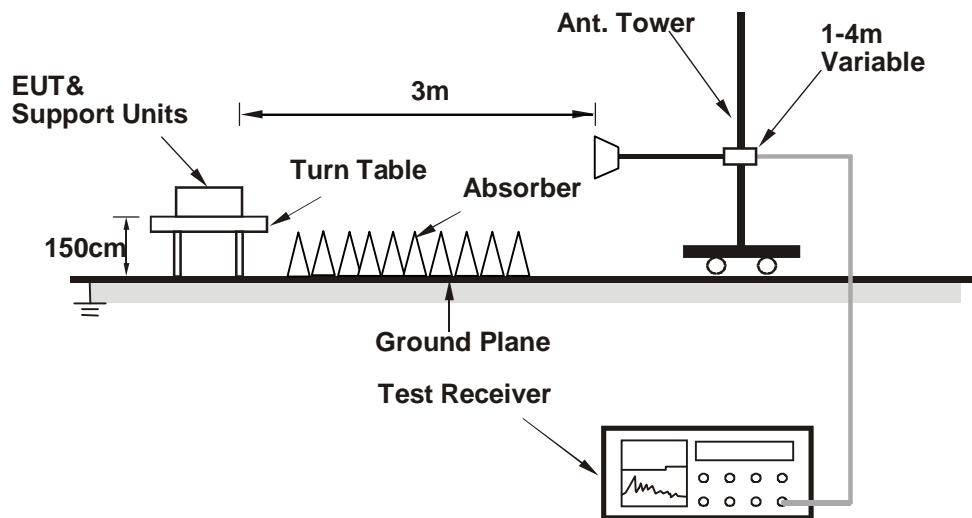

For the actual test configuration, please refer to the attached file (Test Setup Photo).

4.1.6 EUT Operating Condition

- Connected the EUT with AC adapter / PoE adapter placed on testing table.
- Prepared notebook to act as communication partner and placed it outside of testing area.
- The EUT perform R/W function with USB flash from notebook via LAN cable.
- The communication partner connected with EUT via a RJ45 cable and ran a test program (provided by manufacturer) to enable EUT under transmission condition continuously at specific channel frequency.

4.1.7 Test Results

CDD MODE
ABOVE 1GHz DATA
802.11a

CHANNEL	TX Channel 36	DETECTOR FUNCTION	Peak (PK)
FREQUENCY RANGE	1GHz ~ 40GHz		Average (AV)
TEST MODE	A		

ANTENNA POLARITY & TEST DISTANCE: HORIZONTAL AT 3 M

NO.	FREQ. (MHz)	EMISSION LEVEL (dBuV/m)	LIMIT (dBuV/m)	MARGIN (dB)	ANTENNA HEIGHT (m)	TABLE ANGLE (Degree)	RAW VALUE (dBuV)	CORRECTION FACTOR (dB/m)
1	5150.00	72.83 PK	74.00	-1.17	1.77 H	323	64.88	7.95
2	5150.00	52.98 AV	54.00	-1.02	1.77 H	323	45.03	7.95
3	*5180.00	116.66 PK			1.77 H	323	108.57	8.09
4	*5180.00	102.92 AV			1.77 H	323	94.83	8.09
5	#10360.00	58.43 PK	74.00	-15.57	2.86 H	126	40.55	17.88
6	#10360.00	44.76 AV	54.00	-9.24	2.86 H	126	26.88	17.88

ANTENNA POLARITY & TEST DISTANCE: VERTICAL AT 3 M

NO.	FREQ. (MHz)	EMISSION LEVEL (dBuV/m)	LIMIT (dBuV/m)	MARGIN (dB)	ANTENNA HEIGHT (m)	TABLE ANGLE (Degree)	RAW VALUE (dBuV)	CORRECTION FACTOR (dB/m)
1	5150.00	69.20 PK	74.00	-4.80	1.99 V	329	61.25	7.95
2	5150.00	49.29 AV	54.00	-4.71	1.99 V	329	41.34	7.95
3	*5180.00	110.04 PK			1.99 V	329	101.95	8.09
4	*5180.00	96.34 AV			1.99 V	329	88.25	8.09
5	#10360.00	57.52 PK	74.00	-16.48	1.59 V	95	39.64	17.88
6	#10360.00	43.14 AV	54.00	-10.86	1.59 V	95	25.26	17.88

REMARKS:

1. Emission Level(dBuV/m) = Raw Value(dBuV) + Correction Factor(dB/m)
2. Correction Factor(dB/m) = Antenna Factor(dB/m) + Cable Factor(dB) – Pre-Amplifier Factor(dB)
3. The other emission levels were very low against the limit.
4. Margin value = Emission Level – Limit value
5. " * ": Fundamental frequency.
6. " # ": The radiated frequency is out of the restricted band.

CHANNEL	TX Channel 40	DETECTOR FUNCTION	Peak (PK)
FREQUENCY RANGE	1GHz ~ 40GHz		Average (AV)
TEST MODE	A		

ANTENNA POLARITY & TEST DISTANCE: HORIZONTAL AT 3 M

NO.	FREQ. (MHz)	EMISSION LEVEL (dBuV/m)	LIMIT (dBuV/m)	MARGIN (dB)	ANTENNA HEIGHT (m)	TABLE ANGLE (Degree)	RAW VALUE (dBuV)	CORRECTION FACTOR (dB/m)
1	*5200.00	116.03 PK			3.06 H	212	107.85	8.18
2	*5200.00	103.11 AV			3.06 H	212	94.93	8.18
3	#10400.00	60.86 PK	74.00	-13.14	1.85 H	235	42.85	18.01
4	#10400.00	47.89 AV	54.00	-6.11	1.85 H	235	29.88	18.01

ANTENNA POLARITY & TEST DISTANCE: VERTICAL AT 3 M

NO.	FREQ. (MHz)	EMISSION LEVEL (dBuV/m)	LIMIT (dBuV/m)	MARGIN (dB)	ANTENNA HEIGHT (m)	TABLE ANGLE (Degree)	RAW VALUE (dBuV)	CORRECTION FACTOR (dB/m)
1	*5200.00	108.43 PK			2.06 V	268	100.25	8.18
2	*5200.00	95.77 AV			2.06 V	268	87.59	8.18
3	#10400.00	58.12 PK	74.00	-15.88	2.06 V	13	40.11	18.01
4	#10400.00	44.89 AV	54.00	-9.11	2.06 V	13	26.88	18.01

REMARKS:

1. Emission Level(dBuV/m) = Raw Value(dBuV) + Correction Factor(dB/m)
2. Correction Factor(dB/m) = Antenna Factor(dB/m) + Cable Factor(dB) – Pre-Amplifier Factor(dB)
3. The other emission levels were very low against the limit.
4. Margin value = Emission Level – Limit value
5. " * ": Fundamental frequency.
6. " # ": The radiated frequency is out of the restricted band.

CHANNEL	TX Channel 48	DETECTOR FUNCTION	Peak (PK)
FREQUENCY RANGE	1GHz ~ 40GHz		Average (AV)
TEST MODE	A		

ANTENNA POLARITY & TEST DISTANCE: HORIZONTAL AT 3 M

NO.	FREQ. (MHz)	EMISSION LEVEL (dBuV/m)	LIMIT (dBuV/m)	MARGIN (dB)	ANTENNA HEIGHT (m)	TABLE ANGLE (Degree)	RAW VALUE (dBuV)	CORRECTION FACTOR (dB/m)
1	*5240.00	117.82 PK			3.29 H	210	109.58	8.24
2	*5240.00	103.55 AV			3.29 H	210	95.31	8.24
3	5350.00	59.58 PK	74.00	-14.42	3.29 H	210	51.11	8.47
4	5350.00	45.68 AV	54.00	-8.32	3.29 H	210	37.21	8.47
5	#10480.00	59.59 PK	74.00	-14.41	1.74 H	241	41.22	18.37
6	#10480.00	45.80 AV	54.00	-8.20	1.74 H	241	27.43	18.37

ANTENNA POLARITY & TEST DISTANCE: VERTICAL AT 3 M

NO.	FREQ. (MHz)	EMISSION LEVEL (dBuV/m)	LIMIT (dBuV/m)	MARGIN (dB)	ANTENNA HEIGHT (m)	TABLE ANGLE (Degree)	RAW VALUE (dBuV)	CORRECTION FACTOR (dB/m)
1	*5240.00	110.69 PK			2.31 V	289	102.45	8.24
2	*5240.00	97.20 AV			2.31 V	289	88.96	8.24
3	5350.00	59.16 PK	74.00	-14.84	2.31 V	289	50.69	8.47
4	5350.00	45.35 AV	54.00	-8.65	2.31 V	289	36.88	8.47
5	#10480.00	58.92 PK	74.00	-15.08	1.69 V	123	40.55	18.37
6	#10480.00	45.20 AV	54.00	-8.80	1.69 V	123	26.83	18.37

REMARKS:

1. Emission Level(dBuV/m) = Raw Value(dBuV) + Correction Factor(dB/m)
2. Correction Factor(dB/m) = Antenna Factor(dB/m) + Cable Factor(dB) – Pre-Amplifier Factor(dB)
3. The other emission levels were very low against the limit.
4. Margin value = Emission Level – Limit value
5. " * ": Fundamental frequency.
6. " # ": The radiated frequency is out of the restricted band.

CHANNEL	TX Channel 149	DETECTOR FUNCTION	Peak (PK)
FREQUENCY RANGE	1GHz ~ 40GHz		Average (AV)
TEST MODE	A		

ANTENNA POLARITY & TEST DISTANCE: HORIZONTAL AT 3 M

NO.	FREQ. (MHz)	EMISSION LEVEL (dBuV/m)	LIMIT (dBuV/m)	MARGIN (dB)	ANTENNA HEIGHT (m)	TABLE ANGLE (Degree)	RAW VALUE (dBuV)	CORRECTION FACTOR (dB/m)
1	#5629.56	59.94 PK	68.20	-8.26	1.76 H	307	50.24	9.70
2	*5745.00	115.90 PK			1.76 H	307	106.34	9.56
3	*5745.00	103.00 AV			1.76 H	307	93.44	9.56
4	#5927.84	58.93 PK	68.20	-9.27	1.76 H	307	49.25	9.68
5	11490.00	57.66 PK	74.00	-16.34	1.52 H	169	37.69	19.97
6	11490.00	43.52 AV	54.00	-10.48	1.52 H	169	23.55	19.97

ANTENNA POLARITY & TEST DISTANCE: VERTICAL AT 3 M

NO.	FREQ. (MHz)	EMISSION LEVEL (dBuV/m)	LIMIT (dBuV/m)	MARGIN (dB)	ANTENNA HEIGHT (m)	TABLE ANGLE (Degree)	RAW VALUE (dBuV)	CORRECTION FACTOR (dB/m)
1	#5601.49	59.35 PK	68.20	-8.85	1.90 V	271	49.66	9.69
2	*5745.00	113.18 PK			1.90 V	271	103.62	9.56
3	*5745.00	99.69 AV			1.90 V	271	90.13	9.56
4	#5971.16	59.02 PK	68.20	-9.18	1.90 V	271	49.13	9.89
5	11490.00	56.42 PK	74.00	-17.58	2.51 V	334	36.45	19.97
6	11490.00	42.56 AV	54.00	-11.44	2.51 V	334	22.59	19.97

REMARKS:

1. Emission Level(dBuV/m) = Raw Value(dBuV) + Correction Factor(dB/m)
2. Correction Factor(dB/m) = Antenna Factor(dB/m) + Cable Factor(dB) – Pre-Amplifier Factor(dB)
3. The other emission levels were very low against the limit.
4. Margin value = Emission Level – Limit value
5. " * ": Fundamental frequency.
6. " # ": The radiated frequency is out of the restricted band.

CHANNEL	TX Channel 157	DETECTOR FUNCTION	Peak (PK)
FREQUENCY RANGE	1GHz ~ 40GHz		Average (AV)
TEST MODE	A		

ANTENNA POLARITY & TEST DISTANCE: HORIZONTAL AT 3 M

NO.	FREQ. (MHz)	EMISSION LEVEL (dBuV/m)	LIMIT (dBuV/m)	MARGIN (dB)	ANTENNA HEIGHT (m)	TABLE ANGLE (Degree)	RAW VALUE (dBuV)	CORRECTION FACTOR (dB/m)
1	#5585.17	60.14 PK	68.20	-8.06	1.87 H	306	50.49	9.65
2	*5785.00	116.18 PK			1.87 H	306	106.73	9.45
3	*5785.00	103.23 AV			1.87 H	306	93.78	9.45
4	#5994.96	59.95 PK	68.20	-8.25	1.87 H	306	49.95	10.00
5	11570.00	57.81 PK	74.00	-16.19	1.69 H	285	37.49	20.32
6	11570.00	44.20 AV	54.00	-9.80	1.69 H	285	23.88	20.32

ANTENNA POLARITY & TEST DISTANCE: VERTICAL AT 3 M

NO.	FREQ. (MHz)	EMISSION LEVEL (dBuV/m)	LIMIT (dBuV/m)	MARGIN (dB)	ANTENNA HEIGHT (m)	TABLE ANGLE (Degree)	RAW VALUE (dBuV)	CORRECTION FACTOR (dB/m)
1	#5567.06	59.35 PK	68.20	-8.85	1.89 V	268	49.76	9.59
2	*5785.00	113.03 PK			1.89 V	268	103.58	9.45
3	*5785.00	100.00 AV			1.89 V	268	90.55	9.45
4	#5929.77	59.88 PK	68.20	-8.32	1.89 V	268	50.18	9.70
5	11570.00	56.67 PK	74.00	-17.33	1.42 V	105	36.35	20.32
6	11570.00	43.07 AV	54.00	-10.93	1.42 V	105	22.75	20.32

REMARKS:

1. Emission Level(dBuV/m) = Raw Value(dBuV) + Correction Factor(dB/m)
2. Correction Factor(dB/m) = Antenna Factor(dB/m) + Cable Factor(dB) – Pre-Amplifier Factor(dB)
3. The other emission levels were very low against the limit.
4. Margin value = Emission Level – Limit value
5. " * ": Fundamental frequency.
6. " # ": The radiated frequency is out of the restricted band.

CHANNEL	TX Channel 165	DETECTOR FUNCTION	Peak (PK)
FREQUENCY RANGE	1GHz ~ 40GHz		Average (AV)
TEST MODE	A		

ANTENNA POLARITY & TEST DISTANCE: HORIZONTAL AT 3 M

NO.	FREQ. (MHz)	EMISSION LEVEL (dBuV/m)	LIMIT (dBuV/m)	MARGIN (dB)	ANTENNA HEIGHT (m)	TABLE ANGLE (Degree)	RAW VALUE (dBuV)	CORRECTION FACTOR (dB/m)
1	#5615.09	59.38 PK	68.20	-8.82	1.92 H	305	49.68	9.70
2	*5825.00	116.22 PK			1.92 H	305	106.79	9.43
3	*5825.00	103.09 AV			1.92 H	305	93.66	9.43
4	#5952.37	59.17 PK	68.20	-9.03	1.92 H	305	49.37	9.80
5	11650.00	57.91 PK	74.00	-16.09	1.80 H	195	37.64	20.27
6	11650.00	44.23 AV	54.00	-9.77	1.80 H	195	23.96	20.27

ANTENNA POLARITY & TEST DISTANCE: VERTICAL AT 3 M

NO.	FREQ. (MHz)	EMISSION LEVEL (dBuV/m)	LIMIT (dBuV/m)	MARGIN (dB)	ANTENNA HEIGHT (m)	TABLE ANGLE (Degree)	RAW VALUE (dBuV)	CORRECTION FACTOR (dB/m)
1	#5612.02	59.35 PK	68.20	-8.85	2.03 V	269	49.64	9.71
2	*5825.00	112.64 PK			2.03 V	269	103.21	9.43
3	*5825.00	99.96 AV			2.03 V	269	90.53	9.43
4	#5948.95	59.75 PK	68.20	-8.45	2.03 V	269	49.97	9.78
5	11650.00	56.70 PK	74.00	-17.30	2.15 V	222	36.43	20.27
6	11650.00	43.13 AV	54.00	-10.87	2.15 V	222	22.86	20.27

REMARKS:

1. Emission Level(dBuV/m) = Raw Value(dBuV) + Correction Factor(dB/m)
2. Correction Factor(dB/m) = Antenna Factor(dB/m) + Cable Factor(dB) – Pre-Amplifier Factor(dB)
3. The other emission levels were very low against the limit.
4. Margin value = Emission Level – Limit value
5. " * ": Fundamental frequency.
6. " # ": The radiated frequency is out of the restricted band.

802.11n (20MHz)

CHANNEL	TX Channel 36	DETECTOR FUNCTION	Peak (PK)
FREQUENCY RANGE	1GHz ~ 40GHz		Average (AV)
TEST MODE	A		

ANTENNA POLARITY & TEST DISTANCE: HORIZONTAL AT 3 M

NO.	FREQ. (MHz)	EMISSION LEVEL (dBuV/m)	LIMIT (dBuV/m)	MARGIN (dB)	ANTENNA HEIGHT (m)	TABLE ANGLE (Degree)	RAW VALUE (dBuV)	CORRECTION FACTOR (dB/m)
1	5150.00	69.90 PK	74.00	-4.10	1.96 H	317	61.95	7.95
2	5150.00	52.97 AV	54.00	-1.03	1.96 H	317	45.02	7.95
3	*5180.00	116.70 PK			1.96 H	317	108.61	8.09
4	*5180.00	103.44 AV			1.96 H	317	95.35	8.09
5	#10360.00	58.24 PK	74.00	-15.76	1.69 H	243	40.36	17.88
6	#10360.00	44.10 AV	54.00	-9.90	1.69 H	243	26.22	17.88

ANTENNA POLARITY & TEST DISTANCE: VERTICAL AT 3 M

NO.	FREQ. (MHz)	EMISSION LEVEL (dBuV/m)	LIMIT (dBuV/m)	MARGIN (dB)	ANTENNA HEIGHT (m)	TABLE ANGLE (Degree)	RAW VALUE (dBuV)	CORRECTION FACTOR (dB/m)
1	5150.00	62.85 PK	74.00	-11.15	2.56 V	269	54.90	7.95
2	5150.00	47.98 AV	54.00	-6.02	2.56 V	269	40.03	7.95
3	*5180.00	113.30 PK			2.56 V	269	105.21	8.09
4	*5180.00	100.50 AV			2.56 V	269	92.41	8.09
5	#10360.00	57.56 PK	74.00	-16.44	1.52 V	112	39.68	17.88
6	#10360.00	43.31 AV	54.00	-10.69	1.52 V	112	25.43	17.88

REMARKS:

1. Emission Level(dBuV/m) = Raw Value(dBuV) + Correction Factor(dB/m)
2. Correction Factor(dB/m) = Antenna Factor(dB/m) + Cable Factor(dB) – Pre-Amplifier Factor(dB)
3. The other emission levels were very low against the limit.
4. Margin value = Emission Level – Limit value
5. " * ": Fundamental frequency.
6. " # ": The radiated frequency is out of the restricted band.

CHANNEL	TX Channel 40	DETECTOR FUNCTION	Peak (PK)
FREQUENCY RANGE	1GHz ~ 40GHz		Average (AV)
TEST MODE	A		

ANTENNA POLARITY & TEST DISTANCE: HORIZONTAL AT 3 M

NO.	FREQ. (MHz)	EMISSION LEVEL (dBuV/m)	LIMIT (dBuV/m)	MARGIN (dB)	ANTENNA HEIGHT (m)	TABLE ANGLE (Degree)	RAW VALUE (dBuV)	CORRECTION FACTOR (dB/m)
1	*5200.00	118.34 PK			1.86 H	314	110.16	8.18
2	*5200.00	105.56 AV			1.86 H	314	97.38	8.18
3	#10400.00	58.19 PK	74.00	-15.81	1.57 H	211	40.18	18.01
4	#10400.00	44.56 AV	54.00	-9.44	1.57 H	211	26.55	18.01

ANTENNA POLARITY & TEST DISTANCE: VERTICAL AT 3 M

NO.	FREQ. (MHz)	EMISSION LEVEL (dBuV/m)	LIMIT (dBuV/m)	MARGIN (dB)	ANTENNA HEIGHT (m)	TABLE ANGLE (Degree)	RAW VALUE (dBuV)	CORRECTION FACTOR (dB/m)
1	*5200.00	115.43 PK			2.41 V	272	107.25	8.18
2	*5200.00	102.86 AV			2.41 V	272	94.68	8.18
3	#10400.00	57.85 PK	74.00	-16.15	2.50 V	161	39.84	18.01
4	#10400.00	43.82 AV	54.00	-10.18	2.50 V	161	25.81	18.01

REMARKS:

1. Emission Level(dBuV/m) = Raw Value(dBuV) + Correction Factor(dB/m)
2. Correction Factor(dB/m) = Antenna Factor(dB/m) + Cable Factor(dB) – Pre-Amplifier Factor(dB)
3. The other emission levels were very low against the limit.
4. Margin value = Emission Level – Limit value
5. " * ": Fundamental frequency.
6. " # ": The radiated frequency is out of the restricted band.

CHANNEL	TX Channel 48	DETECTOR FUNCTION	Peak (PK)
FREQUENCY RANGE	1GHz ~ 40GHz		Average (AV)
TEST MODE	A		

ANTENNA POLARITY & TEST DISTANCE: HORIZONTAL AT 3 M

NO.	FREQ. (MHz)	EMISSION LEVEL (dBuV/m)	LIMIT (dBuV/m)	MARGIN (dB)	ANTENNA HEIGHT (m)	TABLE ANGLE (Degree)	RAW VALUE (dBuV)	CORRECTION FACTOR (dB/m)
1	*5240.00	118.05 PK			1.84 H	317	109.81	8.24
2	*5240.00	104.82 AV			1.84 H	317	96.58	8.24
3	5350.00	60.28 PK	74.00	-13.72	1.84 H	317	51.81	8.47
4	5350.00	45.81 AV	54.00	-8.19	1.84 H	317	37.34	8.47
5	#10480.00	59.00 PK	74.00	-15.00	1.92 H	330	40.63	18.37
6	#10480.00	44.58 AV	54.00	-9.42	1.92 H	330	26.21	18.37

ANTENNA POLARITY & TEST DISTANCE: VERTICAL AT 3 M

NO.	FREQ. (MHz)	EMISSION LEVEL (dBuV/m)	LIMIT (dBuV/m)	MARGIN (dB)	ANTENNA HEIGHT (m)	TABLE ANGLE (Degree)	RAW VALUE (dBuV)	CORRECTION FACTOR (dB/m)
1	*5240.00	115.09 PK			2.55 V	281	106.85	8.24
2	*5240.00	101.92 AV			2.55 V	281	93.68	8.24
3	5350.00	58.75 PK	74.00	-15.25	2.55 V	281	50.28	8.47
4	5350.00	45.43 AV	54.00	-8.57	2.55 V	281	36.96	8.47
5	#10480.00	57.51 PK	74.00	-16.49	2.18 V	219	39.14	18.37
6	#10480.00	44.19 AV	54.00	-9.81	2.18 V	219	25.82	18.37

REMARKS:

1. Emission Level(dBuV/m) = Raw Value(dBuV) + Correction Factor(dB/m)
2. Correction Factor(dB/m) = Antenna Factor(dB/m) + Cable Factor(dB) – Pre-Amplifier Factor(dB)
3. The other emission levels were very low against the limit.
4. Margin value = Emission Level – Limit value
5. " * ": Fundamental frequency.
6. " # ": The radiated frequency is out of the restricted band.

CHANNEL	TX Channel 149	DETECTOR FUNCTION	Peak (PK)
FREQUENCY RANGE	1GHz ~ 40GHz		Average (AV)
TEST MODE	A		

ANTENNA POLARITY & TEST DISTANCE: HORIZONTAL AT 3 M

NO.	FREQ. (MHz)	EMISSION LEVEL (dBuV/m)	LIMIT (dBuV/m)	MARGIN (dB)	ANTENNA HEIGHT (m)	TABLE ANGLE (Degree)	RAW VALUE (dBuV)	CORRECTION FACTOR (dB/m)
1	#5579.62	59.88 PK	68.20	-8.32	1.85 H	309	50.25	9.63
2	*5745.00	115.68 PK			1.85 H	309	106.12	9.56
3	*5745.00	102.45 AV			1.85 H	309	92.89	9.56
4	#6005.45	59.27 PK	68.20	-8.93	1.85 H	309	49.20	10.07
5	11490.00	57.11 PK	74.00	-16.89	1.51 H	241	37.14	19.97
6	11490.00	43.31 AV	54.00	-10.69	1.51 H	241	23.34	19.97

ANTENNA POLARITY & TEST DISTANCE: VERTICAL AT 3 M

NO.	FREQ. (MHz)	EMISSION LEVEL (dBuV/m)	LIMIT (dBuV/m)	MARGIN (dB)	ANTENNA HEIGHT (m)	TABLE ANGLE (Degree)	RAW VALUE (dBuV)	CORRECTION FACTOR (dB/m)
1	#5616.74	60.40 PK	68.20	-7.80	1.89 V	288	50.71	9.69
2	*5745.00	112.14 PK			1.89 V	288	102.58	9.56
3	*5745.00	99.22 AV			1.89 V	288	89.66	9.56
4	#6012.21	59.59 PK	68.20	-8.61	1.89 V	288	49.47	10.12
5	11490.00	56.84 PK	74.00	-17.16	2.39 V	188	36.87	19.97
6	11490.00	42.56 AV	54.00	-11.44	2.39 V	188	22.59	19.97

REMARKS:

1. Emission Level(dBuV/m) = Raw Value(dBuV) + Correction Factor(dB/m)
2. Correction Factor(dB/m) = Antenna Factor(dB/m) + Cable Factor(dB) – Pre-Amplifier Factor(dB)
3. The other emission levels were very low against the limit.
4. Margin value = Emission Level – Limit value
5. " * ": Fundamental frequency.
6. " # ": The radiated frequency is out of the restricted band.

CHANNEL	TX Channel 157	DETECTOR FUNCTION	Peak (PK)
FREQUENCY RANGE	1GHz ~ 40GHz		Average (AV)
TEST MODE	A		

ANTENNA POLARITY & TEST DISTANCE: HORIZONTAL AT 3 M

NO.	FREQ. (MHz)	EMISSION LEVEL (dBuV/m)	LIMIT (dBuV/m)	MARGIN (dB)	ANTENNA HEIGHT (m)	TABLE ANGLE (Degree)	RAW VALUE (dBuV)	CORRECTION FACTOR (dB/m)
1	#5601.31	59.82 PK	68.20	-8.38	2.05 H	305	50.12	9.70
2	*5785.00	115.88 PK			1.85 H	309	106.43	9.45
3	*5785.00	103.12 AV			1.85 H	309	93.67	9.45
4	#6007.20	59.03 PK	68.20	-9.17	2.05 H	305	48.95	10.08
5	11570.00	57.80 PK	74.00	-16.20	3.14 H	274	37.48	20.32
6	11570.00	44.17 AV	54.00	-9.83	3.14 H	274	23.85	20.32

ANTENNA POLARITY & TEST DISTANCE: VERTICAL AT 3 M

NO.	FREQ. (MHz)	EMISSION LEVEL (dBuV/m)	LIMIT (dBuV/m)	MARGIN (dB)	ANTENNA HEIGHT (m)	TABLE ANGLE (Degree)	RAW VALUE (dBuV)	CORRECTION FACTOR (dB/m)
1	#5603.39	59.22 PK	68.20	-8.98	1.77 V	293	49.52	9.70
2	*5785.00	112.81 PK			1.77 V	293	103.36	9.45
3	*5785.00	99.67 AV			1.77 V	293	90.22	9.45
4	#5951.60	58.75 PK	68.20	-9.45	1.77 V	293	48.95	9.80
5	11570.00	56.68 PK	74.00	-17.32	1.69 V	293	36.36	20.32
6	11570.00	42.84 AV	54.00	-11.16	1.69 V	293	22.52	20.32

REMARKS:

1. Emission Level(dBuV/m) = Raw Value(dBuV) + Correction Factor(dB/m)
2. Correction Factor(dB/m) = Antenna Factor(dB/m) + Cable Factor(dB) – Pre-Amplifier Factor(dB)
3. The other emission levels were very low against the limit.
4. Margin value = Emission Level – Limit value
5. " * ": Fundamental frequency.
6. " # ": The radiated frequency is out of the restricted band.

CHANNEL	TX Channel 165	DETECTOR FUNCTION	Peak (PK)
FREQUENCY RANGE	1GHz ~ 40GHz		Average (AV)
TEST MODE	A		

ANTENNA POLARITY & TEST DISTANCE: HORIZONTAL AT 3 M

NO.	FREQ. (MHz)	EMISSION LEVEL (dBuV/m)	LIMIT (dBuV/m)	MARGIN (dB)	ANTENNA HEIGHT (m)	TABLE ANGLE (Degree)	RAW VALUE (dBuV)	CORRECTION FACTOR (dB/m)
1	#5622.13	59.88 PK	68.20	-8.32	2.08 H	307	50.19	9.69
2	*5825.00	115.43 PK			2.08 H	307	106.00	9.43
3	*5825.00	102.32 AV			2.08 H	307	92.89	9.43
4	#5963.96	59.43 PK	68.20	-8.77	2.08 H	307	49.58	9.85
5	11650.00	58.11 PK	74.00	-15.89	1.70 H	151	37.84	20.27
6	11650.00	43.83 AV	54.00	-10.17	1.70 H	151	23.56	20.27

ANTENNA POLARITY & TEST DISTANCE: VERTICAL AT 3 M

NO.	FREQ. (MHz)	EMISSION LEVEL (dBuV/m)	LIMIT (dBuV/m)	MARGIN (dB)	ANTENNA HEIGHT (m)	TABLE ANGLE (Degree)	RAW VALUE (dBuV)	CORRECTION FACTOR (dB/m)
1	#5642.83	59.38 PK	68.20	-8.82	1.99 V	274	49.69	9.69
2	*5825.00	112.30 PK			1.99 V	274	102.87	9.43
3	*5825.00	99.12 AV			1.99 V	274	89.69	9.43
4	#5987.52	58.75 PK	68.20	-9.45	1.99 V	274	48.77	9.98
5	11650.00	56.86 PK	74.00	-17.14	2.58 V	203	36.59	20.27
6	11650.00	42.80 AV	54.00	-11.20	2.58 V	203	22.53	20.27

REMARKS:

1. Emission Level(dBuV/m) = Raw Value(dBuV) + Correction Factor(dB/m)
2. Correction Factor(dB/m) = Antenna Factor(dB/m) + Cable Factor(dB) – Pre-Amplifier Factor(dB)
3. The other emission levels were very low against the limit.
4. Margin value = Emission Level – Limit value
5. " * ": Fundamental frequency.
6. " # ": The radiated frequency is out of the restricted band.

802.11n (40MHz)

CHANNEL	TX Channel 38	DETECTOR FUNCTION	Peak (PK)
FREQUENCY RANGE	1GHz ~ 40GHz		Average (AV)
TEST MODE	A		

ANTENNA POLARITY & TEST DISTANCE: HORIZONTAL AT 3 M

NO.	FREQ. (MHz)	EMISSION LEVEL (dBuV/m)	LIMIT (dBuV/m)	MARGIN (dB)	ANTENNA HEIGHT (m)	TABLE ANGLE (Degree)	RAW VALUE (dBuV)	CORRECTION FACTOR (dB/m)
1	5150.00	71.29 PK	74.00	-2.71	1.72 H	316	63.34	7.95
2	5150.00	52.84 AV	54.00	-1.16	1.72 H	316	44.89	7.95
3	*5190.00	113.55 PK			1.72 H	316	105.42	8.13
4	*5190.00	100.65 AV			1.72 H	316	92.52	8.13
5	#10380.00	59.27 PK	74.00	-14.73	2.19 H	48	41.32	17.95
6	#10380.00	45.54 AV	54.00	-8.46	2.19 H	48	27.59	17.95

ANTENNA POLARITY & TEST DISTANCE: VERTICAL AT 3 M

NO.	FREQ. (MHz)	EMISSION LEVEL (dBuV/m)	LIMIT (dBuV/m)	MARGIN (dB)	ANTENNA HEIGHT (m)	TABLE ANGLE (Degree)	RAW VALUE (dBuV)	CORRECTION FACTOR (dB/m)
1	5150.00	67.59 PK	74.00	-6.41	2.48 V	273	59.64	7.95
2	5150.00	47.83 AV	54.00	-6.17	2.48 V	273	39.88	7.95
3	*5190.00	110.71 PK			2.48 V	273	102.58	8.13
4	*5190.00	97.82 AV			2.48 V	273	89.69	8.13
5	#10480.00	58.37 PK	74.00	-15.63	1.20 V	187	40.00	18.37
6	#10480.00	44.91 AV	54.00	-9.09	1.20 V	187	26.54	18.37

REMARKS:

1. Emission Level(dBuV/m) = Raw Value(dBuV) + Correction Factor(dB/m)
2. Correction Factor(dB/m) = Antenna Factor(dB/m) + Cable Factor(dB) – Pre-Amplifier Factor(dB)
3. The other emission levels were very low against the limit.
4. Margin value = Emission Level – Limit value
5. " * ": Fundamental frequency.
6. " # ": The radiated frequency is out of the restricted band.

CHANNEL	TX Channel 46	DETECTOR FUNCTION	Peak (PK)
FREQUENCY RANGE	1GHz ~ 40GHz		Average (AV)
TEST MODE	A		

ANTENNA POLARITY & TEST DISTANCE: HORIZONTAL AT 3 M

NO.	FREQ. (MHz)	EMISSION LEVEL (dBuV/m)	LIMIT (dBuV/m)	MARGIN (dB)	ANTENNA HEIGHT (m)	TABLE ANGLE (Degree)	RAW VALUE (dBuV)	CORRECTION FACTOR (dB/m)
1	*5230.00	114.51 PK			1.74 H	316	106.28	8.23
2	*5230.00	101.20 AV			1.74 H	316	92.97	8.23
3	5350.00	59.80 PK	74.00	-14.20	1.74 H	316	51.33	8.47
4	5350.00	45.89 AV	54.00	-8.11	1.74 H	316	37.42	8.47
5	#10460.00	58.95 PK	74.00	-15.05	1.42 H	114	40.67	18.28
6	#10460.00	44.94 AV	54.00	-9.06	1.42 H	114	26.66	18.28

ANTENNA POLARITY & TEST DISTANCE: VERTICAL AT 3 M

NO.	FREQ. (MHz)	EMISSION LEVEL (dBuV/m)	LIMIT (dBuV/m)	MARGIN (dB)	ANTENNA HEIGHT (m)	TABLE ANGLE (Degree)	RAW VALUE (dBuV)	CORRECTION FACTOR (dB/m)
1	*5230.00	111.67 PK			2.63 V	271	103.44	8.23
2	*5230.00	98.59 AV			2.63 V	271	90.36	8.23
3	5350.00	58.89 PK	74.00	-15.11	2.63 V	271	50.42	8.47
4	5350.00	45.36 AV	54.00	-8.64	2.63 V	271	36.89	8.47
5	#10460.00	58.15 PK	74.00	-15.85	2.39 V	168	39.87	18.28
6	#10460.00	43.57 AV	54.00	-10.43	2.39 V	168	25.29	18.28

REMARKS:

1. Emission Level(dBuV/m) = Raw Value(dBuV) + Correction Factor(dB/m)
2. Correction Factor(dB/m) = Antenna Factor(dB/m) + Cable Factor(dB) – Pre-Amplifier Factor(dB)
3. The other emission levels were very low against the limit.
4. Margin value = Emission Level – Limit value
5. " * ": Fundamental frequency.
6. " # ": The radiated frequency is out of the restricted band.

CHANNEL	TX Channel 151	DETECTOR FUNCTION	Peak (PK)
FREQUENCY RANGE	1GHz ~ 40GHz		Average (AV)
TEST MODE	A		

ANTENNA POLARITY & TEST DISTANCE: HORIZONTAL AT 3 M

NO.	FREQ. (MHz)	EMISSION LEVEL (dBuV/m)	LIMIT (dBuV/m)	MARGIN (dB)	ANTENNA HEIGHT (m)	TABLE ANGLE (Degree)	RAW VALUE (dBuV)	CORRECTION FACTOR (dB/m)
1	#5627.06	60.79 PK	68.20	-7.41	1.87 H	309	51.09	9.70
2	*5755.00	113.17 PK			1.87 H	309	103.63	9.54
3	*5755.00	100.42 AV			1.87 H	309	90.88	9.54
4	#5982.80	60.11 PK	68.20	-8.09	1.87 H	309	50.16	9.95
5	11510.00	57.49 PK	74.00	-16.51	2.21 H	157	37.49	20.00
6	11510.00	43.67 AV	54.00	-10.33	2.21 H	157	23.67	20.00

ANTENNA POLARITY & TEST DISTANCE: VERTICAL AT 3 M

NO.	FREQ. (MHz)	EMISSION LEVEL (dBuV/m)	LIMIT (dBuV/m)	MARGIN (dB)	ANTENNA HEIGHT (m)	TABLE ANGLE (Degree)	RAW VALUE (dBuV)	CORRECTION FACTOR (dB/m)
1	#5647.74	59.42 PK	68.20	-8.78	2.06 V	296	49.72	9.70
2	*5755.00	109.56 PK			2.06 V	296	100.02	9.54
3	*5755.00	97.00 AV			2.06 V	296	87.46	9.54
4	#5993.96	58.80 PK	68.20	-9.40	2.06 V	296	48.80	10.00
5	11510.00	56.33 PK	74.00	-17.67	1.20 V	101	36.33	20.00
6	11510.00	42.50 AV	54.00	-11.50	1.20 V	101	22.50	20.00

REMARKS:

1. Emission Level(dBuV/m) = Raw Value(dBuV) + Correction Factor(dB/m)
2. Correction Factor(dB/m) = Antenna Factor(dB/m) + Cable Factor(dB) – Pre-Amplifier Factor(dB)
3. The other emission levels were very low against the limit.
4. Margin value = Emission Level – Limit value
5. " * ": Fundamental frequency.
6. " # ": The radiated frequency is out of the restricted band.

CHANNEL	TX Channel 159	DETECTOR FUNCTION	Peak (PK)
FREQUENCY RANGE	1GHz ~ 40GHz		Average (AV)
TEST MODE	A		

ANTENNA POLARITY & TEST DISTANCE: HORIZONTAL AT 3 M

NO.	FREQ. (MHz)	EMISSION LEVEL (dBuV/m)	LIMIT (dBuV/m)	MARGIN (dB)	ANTENNA HEIGHT (m)	TABLE ANGLE (Degree)	RAW VALUE (dBuV)	CORRECTION FACTOR (dB/m)
1	#5622.98	60.50 PK	68.20	-7.70	1.83 H	307	50.80	9.70
2	*5795.00	113.40 PK			1.83 H	307	103.98	9.42
3	*5795.00	100.31 AV			1.83 H	307	90.89	9.42
4	#5971.69	59.83 PK	68.20	-8.37	1.83 H	307	49.93	9.90
5	11590.00	58.30 PK	74.00	-15.70	1.53 H	142	37.88	20.42
6	11590.00	44.00 AV	54.00	-10.00	1.53 H	142	23.58	20.42

ANTENNA POLARITY & TEST DISTANCE: VERTICAL AT 3 M

NO.	FREQ. (MHz)	EMISSION LEVEL (dBuV/m)	LIMIT (dBuV/m)	MARGIN (dB)	ANTENNA HEIGHT (m)	TABLE ANGLE (Degree)	RAW VALUE (dBuV)	CORRECTION FACTOR (dB/m)
1	#5596.44	59.44 PK	68.20	-8.76	2.05 V	278	49.74	9.70
2	*5795.00	109.67 PK			2.05 V	278	100.25	9.42
3	*5795.00	96.57 AV			2.05 V	278	87.15	9.42
4	#5996.99	59.53 PK	68.20	-8.67	2.05 V	278	49.52	10.01
5	11590.00	57.36 PK	74.00	-16.64	2.64 V	183	36.94	20.42
6	11590.00	43.06 AV	54.00	-10.94	2.64 V	183	22.64	20.42

REMARKS:

1. Emission Level(dBuV/m) = Raw Value(dBuV) + Correction Factor(dB/m)
2. Correction Factor(dB/m) = Antenna Factor(dB/m) + Cable Factor(dB) – Pre-Amplifier Factor(dB)
3. The other emission levels were very low against the limit.
4. Margin value = Emission Level – Limit value
5. " * ": Fundamental frequency.
6. " # ": The radiated frequency is out of the restricted band.

802.11ac (80MHz)

CHANNEL	TX Channel 42	DETECTOR FUNCTION	Peak (PK)
FREQUENCY RANGE	1GHz ~ 40GHz		Average (AV)
TEST MODE	A		

ANTENNA POLARITY & TEST DISTANCE: HORIZONTAL AT 3 M

NO.	FREQ. (MHz)	EMISSION LEVEL (dBuV/m)	LIMIT (dBuV/m)	MARGIN (dB)	ANTENNA HEIGHT (m)	TABLE ANGLE (Degree)	RAW VALUE (dBuV)	CORRECTION FACTOR (dB/m)
1	5150.00	69.31 PK	74.00	-4.69	1.75 H	316	61.36	7.95
2	5150.00	52.88 AV	54.00	-1.12	1.75 H	316	44.93	7.95
3	*5210.00	106.61 PK			1.75 H	316	98.42	8.19
4	*5210.00	92.78 AV			1.75 H	316	84.59	8.19
5	5350.00	59.49 PK	74.00	-14.51	1.75 H	316	51.02	8.47
6	5350.00	45.92 AV	54.00	-8.08	1.75 H	316	37.45	8.47
7	#10420.00	59.58 PK	74.00	-14.42	1.88 H	200	41.47	18.11
8	#10420.00	45.63 AV	54.00	-8.37	1.88 H	200	27.52	18.11

ANTENNA POLARITY & TEST DISTANCE: VERTICAL AT 3 M

NO.	FREQ. (MHz)	EMISSION LEVEL (dBuV/m)	LIMIT (dBuV/m)	MARGIN (dB)	ANTENNA HEIGHT (m)	TABLE ANGLE (Degree)	RAW VALUE (dBuV)	CORRECTION FACTOR (dB/m)
1	5150.00	63.64 PK	74.00	-10.36	2.45 V	270	55.69	7.95
2	5150.00	46.90 AV	54.00	-7.10	2.45 V	270	38.95	7.95
3	*5210.00	103.97 PK			2.45 V	270	95.78	8.19
4	*5210.00	89.88 AV			2.45 V	270	81.69	8.19
5	5350.00	59.35 PK	74.00	-14.65	2.45 V	270	50.88	8.47
6	5350.00	45.32 AV	54.00	-8.68	2.45 V	270	36.85	8.47
7	#10420.00	58.14 PK	74.00	-15.86	1.87 V	194	40.03	18.11
8	#10420.00	44.14 AV	54.00	-9.86	1.87 V	194	26.03	18.11

REMARKS:

1. Emission Level(dBuV/m) = Raw Value(dBuV) + Correction Factor(dB/m)
2. Correction Factor(dB/m) = Antenna Factor(dB/m) + Cable Factor(dB) – Pre-Amplifier Factor(dB)
3. The other emission levels were very low against the limit.
4. Margin value = Emission Level – Limit value
5. " * ": Fundamental frequency.
6. " # ": The radiated frequency is out of the restricted band.

CHANNEL	TX Channel 155	DETECTOR FUNCTION	Peak (PK)
FREQUENCY RANGE	1GHz ~ 40GHz		Average (AV)
TEST MODE	A		

ANTENNA POLARITY & TEST DISTANCE: HORIZONTAL AT 3 M

NO.	FREQ. (MHz)	EMISSION LEVEL (dBuV/m)	LIMIT (dBuV/m)	MARGIN (dB)	ANTENNA HEIGHT (m)	TABLE ANGLE (Degree)	RAW VALUE (dBuV)	CORRECTION FACTOR (dB/m)
1	#5641.44	65.36 PK	68.20	-2.84	4.00 H	318	55.66	9.70
2	*5775.00	112.46 PK			4.00 H	318	102.98	9.48
3	*5775.00	97.11 AV			4.00 H	318	87.63	9.48
4	#5925.99	66.59 PK	68.20	-1.61	4.00 H	318	56.91	9.68
5	11550.00	58.08 PK	74.00	-15.92	1.66 H	293	37.88	20.20
6	11550.00	43.87 AV	54.00	-10.13	1.66 H	293	23.67	20.20

ANTENNA POLARITY & TEST DISTANCE: VERTICAL AT 3 M

NO.	FREQ. (MHz)	EMISSION LEVEL (dBuV/m)	LIMIT (dBuV/m)	MARGIN (dB)	ANTENNA HEIGHT (m)	TABLE ANGLE (Degree)	RAW VALUE (dBuV)	CORRECTION FACTOR (dB/m)
1	#5638.67	66.13 PK	68.20	-2.07	3.26 V	278	56.43	9.70
2	*5775.00	108.25 PK			3.26 V	278	98.77	9.48
3	*5775.00	94.17 AV			3.26 V	278	84.69	9.48
4	#5940.03	65.26 PK	68.20	-2.94	3.26 V	278	55.52	9.74
5	11550.00	56.68 PK	74.00	-17.32	2.71 V	331	36.48	20.20
6	11550.00	42.72 AV	54.00	-11.28	2.71 V	331	22.52	20.20

REMARKS:

1. Emission Level(dBuV/m) = Raw Value(dBuV) + Correction Factor(dB/m)
2. Correction Factor(dB/m) = Antenna Factor(dB/m) + Cable Factor(dB) – Pre-Amplifier Factor(dB)
3. The other emission levels were very low against the limit.
4. Margin value = Emission Level – Limit value
5. " * ": Fundamental frequency.
6. " # ": The radiated frequency is out of the restricted band.

BELOW 1GHz WORST-CASE DATA

802.11n (20MHz)

CHANNEL	TX Channel 40	DETECTOR FUNCTION	Quasi-Peak (QP)
FREQUENCY RANGE	9kHz ~ 1GHz		
TEST MODE	A		

ANTENNA POLARITY & TEST DISTANCE: HORIZONTAL AT 3 M

NO.	FREQ. (MHz)	EMISSION LEVEL (dBuV/m)	LIMIT (dBuV/m)	MARGIN (dB)	ANTENNA HEIGHT (m)	TABLE ANGLE (Degree)	RAW VALUE (dBuV)	CORRECTION FACTOR (dB/m)
1	77.19	21.32 QP	40.00	-18.68	4.00 H	255	34.71	-13.39
2	151.49	24.91 QP	43.50	-18.59	3.88 H	255	34.18	-9.27
3	523.54	26.18 QP	46.00	-19.82	1.76 H	7	28.92	-2.74
4	832.00	31.50 QP	46.00	-14.50	1.44 H	130	29.16	2.34
5	908.24	32.01 QP	46.00	-13.99	1.00 H	141	28.45	3.56
6	990.59	33.01 QP	54.00	-20.99	1.00 H	293	28.20	4.81

ANTENNA POLARITY & TEST DISTANCE: VERTICAL AT 3 M

NO.	FREQ. (MHz)	EMISSION LEVEL (dBuV/m)	LIMIT (dBuV/m)	MARGIN (dB)	ANTENNA HEIGHT (m)	TABLE ANGLE (Degree)	RAW VALUE (dBuV)	CORRECTION FACTOR (dB/m)
1	34.66	32.11 QP	40.00	-7.89	1.20 V	236	43.30	-11.19
2	66.33	33.64 QP	40.00	-6.36	1.33 V	360	44.72	-11.08
3	101.93	25.13 QP	43.50	-18.37	1.00 V	169	38.84	-13.71
4	155.66	24.11 QP	43.50	-19.39	1.00 V	116	33.23	-9.12
5	693.82	28.37 QP	46.00	-17.63	2.65 V	63	28.37	0.00
6	920.95	32.76 QP	46.00	-13.24	2.18 V	34	28.82	3.94

REMARKS:

1. Emission Level(dBuV/m) = Raw Value(dBuV) + Correction Factor(dB/m)
2. Correction Factor(dB/m) = Antenna Factor(dB/m) + Cable Factor(dB) – Pre-Amplifier Factor(dB)
3. The other emission levels were very low against the limit.
4. Margin value = Emission Level – Limit value

4.2 Conducted Emission Measurement

4.2.1 Limits of Conducted Emission Measurement

Frequency (MHz)	Conducted Limit (dBuV)	
	Quasi-peak	Average
0.15 - 0.5	66 - 56	56 - 46
0.50 - 5.0	56	46
5.0 - 30.0	60	50

Note: 1. The lower limit shall apply at the transition frequencies.

2. The limit decreases in line with the logarithm of the frequency in the range of 0.15 to 0.50MHz.

4.2.2 Test Instruments

Description & Manufacturer	Model No.	Serial No.	Cal. Date	Cal. Due
ROHDE & SCHWARZ TEST RECEIVER	ESCS 30	100276	Apr. 12, 2016	Apr. 11, 2017
ROHDE & SCHWARZ Artificial Mains Network (for EUT)	ENV216	101197	May 04, 2016	May 03, 2017
LISN With Adapter (for EUT)	AD10	C10Ada-002	May 04, 2016	May 03, 2017
ROHDE & SCHWARZ Artificial Mains Network (for peripherals)	ESH3-Z5	100218	Nov. 23, 2016	Nov. 22, 2017
SCHWARZBECK Artificial Mains Network (For EUT)	NNLK8129	8129229	May 04, 2016	May 03, 2017
Software	Cond_V7.3.7.4	NA	NA	NA
RF cable (JYEBAO) With 10dB PAD	5D-FB	Cable-C10.01	Feb. 14, 2017	Feb. 13, 2018
SUHNER Terminator (For ROHDE & SCHWARZ LISN)	65BNC-5001	E1-011484	May 12, 2016	May 11, 2017
ROHDE & SCHWARZ Artificial Mains Network (For TV EUT)	ESH3-Z5	100220	Nov. 08, 2016	Nov. 07, 2017
LISN With Adapter (for TV EUT)	100220	N/A	Nov. 08, 2016	Nov. 07, 2017

Notes: 1. The calibration interval of the above test instruments is 12 months and the calibrations are traceable to NML/ROC and NIST/USA.

2. The test was performed in Shielded Room No. 10.

3. The VCCI Site Registration No. C-1852.

4. Tested Date: Feb. 15, 2017

4.2.3 Test Procedure

- The EUT was placed 0.4 meters from the conducting wall of the shielded room with EUT being connected to the power mains through a line impedance stabilization network (LISN). Other support units were connected to the power mains through another LISN. The two LISNs provide 50 ohm/ 50uH of coupling impedance for the measuring instrument.
- Both lines of the power mains connected to the EUT were checked for maximum conducted interference.
- The frequency range from 150kHz to 30MHz was searched. Emission levels under (Limit - 20dB) was not recorded.

NOTE: All modes of operation were investigated and the worst-case emissions are reported.

4.2.4 Deviation from Test Standard

No deviation.

4.2.5 Test Setup

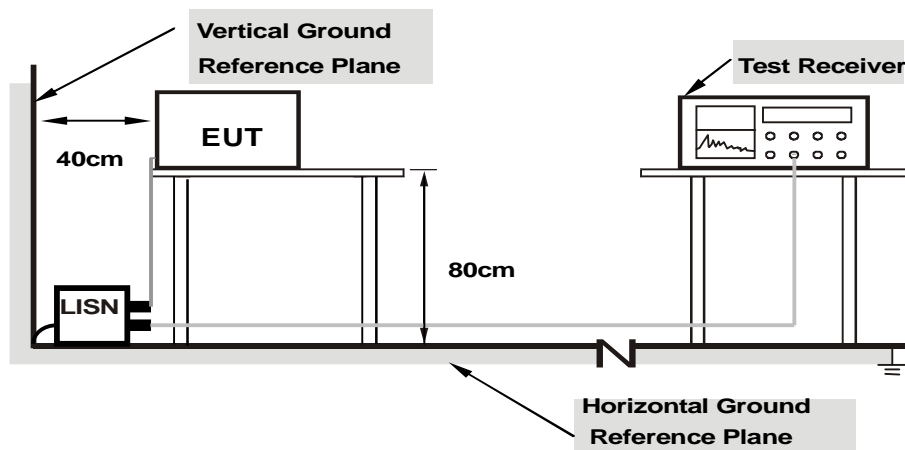

Note: 1.Support units were connected to second LISN.

For the actual test configuration, please refer to the attached file (Test Setup Photo).

4.2.6 EUT Operating Condition

Same as Item 4.1.6.

4.2.7 Test Results

CDD MODE

Phase	Line (L)	Detector Function	Quasi-Peak (QP) / Average (AV)
Test Mode	A		

No	Frequency (MHz)	Correction Factor (dB)	Reading Value (dBuV)		Emission Level (dBuV)		Limit (dBuV)		Margin (dB)	
			Q.P.	AV.	Q.P.	AV.	Q.P.	AV.	Q.P.	AV.
1	0.15001	9.71	34.09	20.36	43.80	30.07	66.00	56.00	-22.20	-25.93
2	0.16172	9.71	33.26	21.71	42.97	31.42	65.38	55.38	-22.41	-23.96
3	0.25547	9.72	31.70	29.37	41.42	39.09	61.58	51.58	-20.16	-12.49
4	0.52891	9.76	13.20	7.50	22.96	17.26	56.00	46.00	-33.04	-28.74
5	0.88438	9.82	7.94	4.80	17.76	14.62	56.00	46.00	-38.24	-31.38
6	3.80078	10.08	11.28	6.02	21.36	16.10	56.00	46.00	-34.64	-29.90
7	10.94141	10.22	12.89	7.46	23.11	17.68	60.00	50.00	-36.89	-32.32

Remarks:

1. Q.P. and AV. are abbreviations of quasi-peak and average individually.
2. The emission levels of other frequencies were very low against the limit.
3. Margin value = Emission level – Limit value
4. Correction factor = Insertion loss + Cable loss
5. Emission Level = Correction Factor + Reading Value

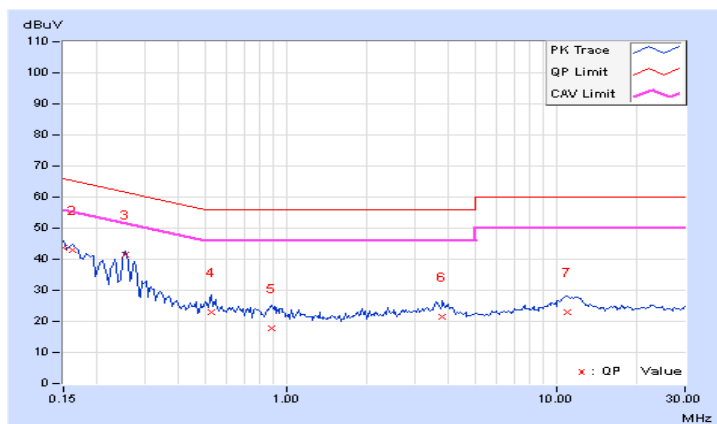

Phase	Neutral (N)	Detector Function	Quasi-Peak (QP) / Average (AV)
Test Mode	A		

No	Frequency (MHz)	Correction Factor (dB)	Reading Value (dBuV)		Emission Level (dBuV)		Limit (dBuV)		Margin (dB)	
			Q.P.	AV.	Q.P.	AV.	Q.P.	AV.	Q.P.	AV.
1	0.15001	9.72	34.43	21.11	44.15	30.83	66.00	56.00	-21.85	-25.17
2	0.16172	9.72	33.70	21.83	43.42	31.55	65.38	55.38	-21.96	-23.83
3	0.25156	9.73	30.24	28.75	39.97	38.48	61.71	51.71	-21.74	-13.23
4	0.53281	9.78	12.35	4.75	22.13	14.53	56.00	46.00	-33.87	-31.47
5	3.71484	10.14	13.38	5.59	23.52	15.73	56.00	46.00	-32.48	-30.27
6	11.69531	10.27	12.00	6.79	22.27	17.06	60.00	50.00	-37.73	-32.94

Remarks:

1. Q.P. and AV. are abbreviations of quasi-peak and average individually.
2. The emission levels of other frequencies were very low against the limit.
3. Margin value = Emission level – Limit value
4. Correction factor = Insertion loss + Cable loss
5. Emission Level = Correction Factor + Reading Value

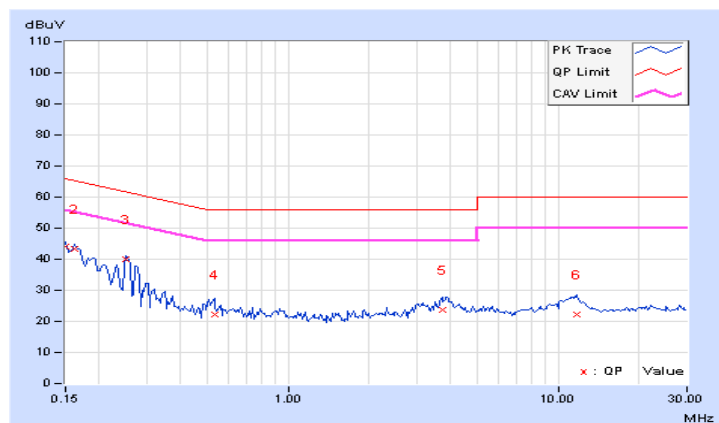

Phase	Line (L)	Detector Function	Quasi-Peak (QP) / Average (AV)
Test Mode	B		

No	Frequency (MHz)	Correction Factor (dB)	Reading Value (dBuV)		Emission Level (dBuV)		Limit (dBuV)		Margin (dB)	
			Q.P.	AV.	Q.P.	AV.	Q.P.	AV.	Q.P.	AV.
1	0.18516	9.71	39.40	18.59	49.11	28.30	64.25	54.25	-15.14	-25.95
2	0.23984	9.71	31.38	9.24	41.09	18.95	62.10	52.10	-21.01	-33.15
3	0.36875	9.71	29.61	12.47	39.32	22.18	58.53	48.53	-19.21	-26.35
4	0.93906	9.75	19.81	4.15	29.56	13.90	56.00	46.00	-26.44	-32.10
5	1.94922	9.79	21.63	9.26	31.42	19.05	56.00	46.00	-24.58	-26.95
6	11.63672	9.96	20.31	15.24	30.27	25.20	60.00	50.00	-29.73	-24.80
7	25.13672	9.99	18.12	12.44	28.11	22.43	60.00	50.00	-31.89	-27.57

Remarks:

1. Q.P. and AV. are abbreviations of quasi-peak and average individually.
2. The emission levels of other frequencies were very low against the limit.
3. Margin value = Emission level – Limit value
4. Correction factor = Insertion loss + Cable loss
5. Emission Level = Correction Factor + Reading Value

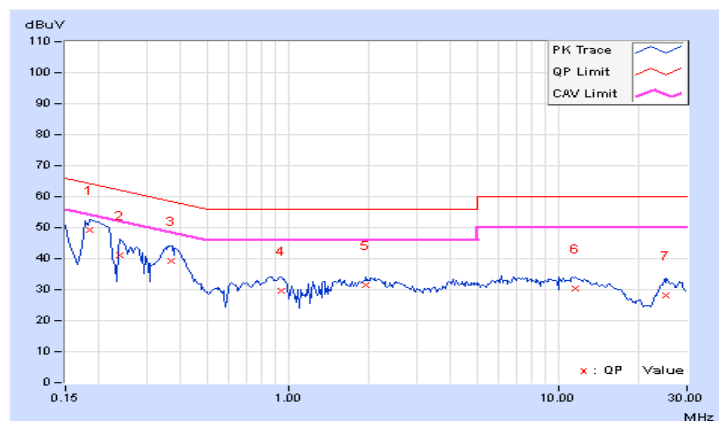

Phase	Neutral (N)	Detector Function	Quasi-Peak (QP) / Average (AV)
Test Mode	B		

No	Frequency (MHz)	Correction Factor (dB)	Reading Value (dBUV)		Emission Level (dBUV)		Limit (dBUV)		Margin (dB)	
			Q.P.	AV.	Q.P.	AV.	Q.P.	AV.	Q.P.	AV.
1	0.18516	9.70	39.52	19.22	49.22	28.92	64.25	54.25	-15.03	-25.33
2	0.20859	9.70	38.71	22.40	48.41	32.10	63.26	53.26	-14.85	-21.16
3	0.25156	9.70	30.83	12.36	40.53	22.06	61.71	51.71	-21.18	-29.65
4	0.36875	9.71	30.17	12.70	39.88	22.41	58.53	48.53	-18.65	-26.12
5	0.75938	9.73	20.15	10.04	29.88	19.77	56.00	46.00	-26.12	-26.23
6	4.24609	9.88	19.47	10.38	29.35	20.26	56.00	46.00	-26.65	-25.74
7	11.06641	9.95	19.91	15.00	29.86	24.95	60.00	50.00	-30.14	-25.05
8	24.48828	9.96	20.17	14.01	30.13	23.97	60.00	50.00	-29.87	-26.03

Remarks:

1. Q.P. and AV. are abbreviations of quasi-peak and average individually.
2. The emission levels of other frequencies were very low against the limit.
3. Margin value = Emission level – Limit value
4. Correction factor = Insertion loss + Cable loss
5. Emission Level = Correction Factor + Reading Value

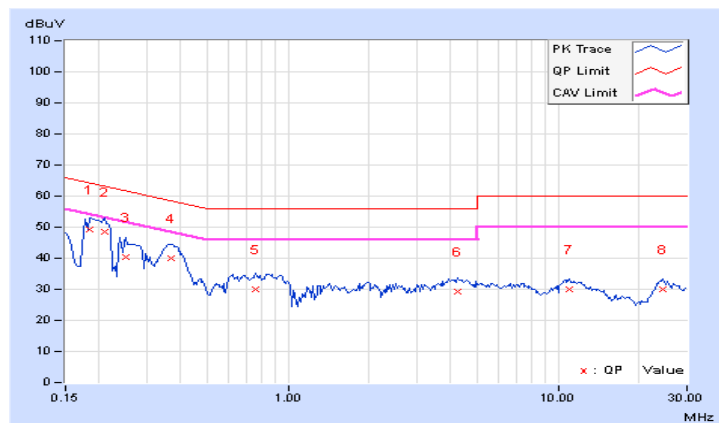

4.3 Transmit Power Measurement

4.3.1 Limits of Transmit Power Measurement

Operation Band	EUT Category		Limit
U-NII-1		Outdoor Access Point	1 Watt (30 dBm) (Max. e.i.r.p \leq 125mW(21 dBm) at any elevation angle above 30 degrees as measured from the horizon)
		Fixed point-to-point Access Point	1 Watt (30 dBm)
	√	Indoor Access Point	1 Watt (30 dBm)
		Mobile and Portable client device	250mW (24 dBm)
U-NII-2A	---		250mW (24 dBm) or 11 dBm+10 log B*
U-NII-2C	---		250mW (24 dBm) or 11 dBm+10 log B*
U-NII-3	√		1 Watt (30 dBm)

*B is the 26 dB emission bandwidth in megahertz

Per KDB 662911 Method of conducted output power measurement on IEEE 802.11 devices,

Array Gain = 0 dB (i.e., no array gain) for $N_{ANT} \leq 4$;

Array Gain = 0 dB (i.e., no array gain) for channel widths ≥ 40 MHz for any N_{ANT} ;

Array Gain = $5 \log(N_{ANT}/N_{SS})$ dB or 3 dB, whichever is less for 20-MHz channel widths with $N_{ANT} \geq 5$.

For power measurements on all other devices: Array Gain = $10 \log(N_{ANT}/N_{SS})$ dB.

4.3.2 Test Setup

FOR POWER OUTPUT MEASUREMENT

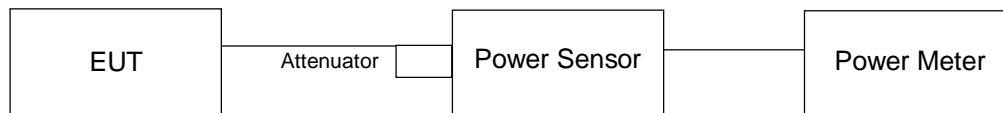

4.3.3 Test Instruments

Refer to section 4.1.2 to get information of above instrument.

4.3.4 Test Procedure

For Average Power Measurement

For 802.11a, 802.11n (20MHz), 802.11n (40MHz)

Method PM is used to perform output power measurement, trigger and gating function of wide band power meter is enabled to measure max output power of TX on burst. Duty factor is not added to measured value.

For 802.11ac (80MHz)

- 1) Set span to encompass the entire 26 dB EBW (or, alternatively, the entire 99% occupied bandwidth) of the signal.
- 2) Set sweep trigger to "free run".
- 3) Set RBW = 1 MHz.
- 4) Set VBW \geq 3 MHz
- 5) Number of points in sweep \geq 2 Span / RBW.
- 6) Sweep time \leq (number of points in sweep) * T
- 7) Using emission bandwidth to determine the frequency span for integration the channel bandwidth.
- 8) Detector = RMS.
- 9) Trace mode = max hold.
- 10) Allow max hold to run for at least 60 seconds, or longer as needed to allow the trace to stabilize.

4.3.5 Deviation from Test Standard

No deviation.

4.3.6 EUT Operating Condition

The software provided by client to enable the EUT under transmission condition continuously at lowest, middle and highest channel frequencies individually.

4.3.7 Test Result

Mode A

Power Output:

CDD MODE

802.11a

CHAN.	FREQ. (MHz)	Maximum Conducted Power (dBm)		Total Power (mW)	Total Power (dBm)	Power Limit (dBm)	Pass/Fail
		CHAIN 0	CHAIN 1				
36	5180	23.09	22.93	400.04	26.02	30	Pass
40	5200	25.51	25.26	691.369	28.40	30	Pass
48	5240	25.14	24.78	627.196	27.97	30	Pass
149	5745	24.66	24.18	554.233	27.44	30	Pass
157	5785	24.34	24.09	528.092	27.23	30	Pass
165	5825	24.46	24.21	542.887	27.35	30	Pass

802.11n (20MHz)

CHAN.	FREQ. (MHz)	Maximum Conducted Power (dBm)		Total Power (mW)	Total Power (dBm)	Power Limit (dBm)	Pass/Fail
		CHAIN 0	CHAIN 1				
36	5180	22.92	22.78	385.555	25.86	30	Pass
40	5200	25.39	25.28	683.226	28.35	30	Pass
48	5240	25.09	24.64	613.921	27.88	30	Pass
149	5745	24.55	24.08	540.961	27.33	30	Pass
157	5785	23.98	23.87	493.816	26.94	30	Pass
165	5825	24.44	24.32	548.367	27.39	30	Pass

802.11n (40MHz)

CHAN.	FREQ. (MHz)	Maximum Conducted Power (dBm)		Total Power (mW)	Total Power (dBm)	Power Limit (dBm)	Pass/Fail
		CHAIN 0	CHAIN 1				
38	5190	23.06	22.89	396.838	25.99	30	Pass
46	5230	24.79	23.98	551.336	27.41	30	Pass
151	5755	23.98	23.25	461.384	26.64	30	Pass
159	5795	23.93	23.74	483.764	26.85	30	Pass

802.11ac (80MHz)

CHAN.	CHAN. FREQ. (MHz)	Maximum Conducted Power (dBm)		Total Power (mW)	Total Power (dBm)	Power Limit (dBm)	Pass/Fail
		CHAIN 0	CHAIN 1				
42	5210	22.93	22.86	389.533	25.91	30	Pass
155	5775	22.59	22.38	354.534	25.50	30	Pass

Beamforming_NSS1 MODE
802.11ac (20MHz)

CHAN.	FREQ. (MHz)	Maximum Conducted Power (dBm)		Total Power (mW)	Total Power (dBm)	Power Limit (dBm)	Pass/Fail
		CHAIN 0	CHAIN 1				
36	5180	22.24	22.12	330.424	25.19	30	Pass
40	5200	22.29	22.07	330.499	25.19	30	Pass
48	5240	22.28	22.09	330.852	25.20	30	Pass
149	5745	22.05	21.82	312.38	24.95	30	Pass
157	5785	21.98	21.76	307.729	24.88	30	Pass
165	5825	21.98	21.78	308.422	24.89	30	Pass

802.11ac (40MHz)

CHAN.	FREQ. (MHz)	Maximum Conducted Power (dBm)		Total Power (mW)	Total Power (dBm)	Power Limit (dBm)	Pass/Fail
		CHAIN 0	CHAIN 1				
38	5190	22.38	22.17	337.798	25.29	30	Pass
46	5230	22.36	22.14	335.869	25.26	30	Pass
151	5755	22.16	21.87	318.252	25.03	30	Pass
159	5795	22.19	21.84	318.334	25.03	30	Pass

802.11ac (80MHz)

CHAN.	CHAN. FREQ. (MHz)	Maximum Conducted Power (dBm)		Total Power (mW)	Total Power (dBm)	Power Limit (dBm)	Pass/Fail
		CHAIN 0	CHAIN 1				
42	5210	22.20	22.07	327.024	25.15	30	Pass
155	5775	21.91	21.67	302.132	24.80	30	Pass

4.4 Occupied Bandwidth Measurement

4.4.1 Test Setup

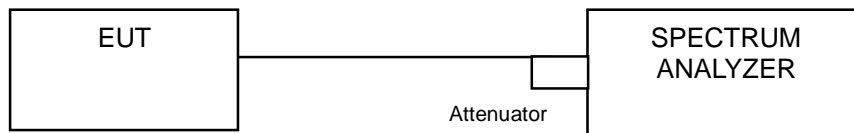

4.4.2 Test Instruments

Refer to section 4.1.2 to get information of above instrument.

4.4.3 Test Procedure

The transmitter output was connected to the spectrum analyzer through an attenuator. The bandwidth of the fundamental frequency was measured by spectrum analyzer with resolution bandwidth in the range of 1% to 5% of the anticipated emission bandwidth, and a video bandwidth at least 3x the resolution bandwidth and set the detector to SAMPLE. The width of a frequency band such that, below the lower and above the upper frequency limits, the mean powers emitted are each equal to a specified percentage 0.5 %of the total mean power of a given emission.

4.4.4 Test Results

Mode A

CDD MODE

802.11a

Channel	Channel Frequency (MHz)	Occupied Bandwidth (MHz)	
		CHAIN 0	CHAIN 1
36	5180	16.56	16.56
40	5200	21.36	21.72
48	5240	17.73	17.39
149	5745	25.91	26.00
157	5785	25.30	25.10
165	5825	29.00	28.10

802.11n (20MHz)

Channel	Channel Frequency (MHz)	Occupied Bandwidth (MHz)	
		CHAIN 0	CHAIN 1
36	5180	17.64	17.76
40	5200	20.16	19.56
48	5240	19.32	19.20
149	5745	28.08	26.50
157	5785	25.50	25.10
165	5825	29.00	28.70

802.11n (40MHz)

Channel	Channel Frequency (MHz)	Occupied Bandwidth (MHz)	
		CHAIN 0	CHAIN 1
38	5190	36.00	36.00
46	5230	37.00	36.80
151	5755	49.13	48.50
159	5795	47.66	46.83

802.11ac (80MHz)

Channel	Channel Frequency (MHz)	Occupied Bandwidth (MHz)	
		CHAIN 0	CHAIN 1
42	5210	75.84	75.84
155	5775	76.28	76.44

Spectrum Plot of Worst Value

802.11a_Chain0 / CH165

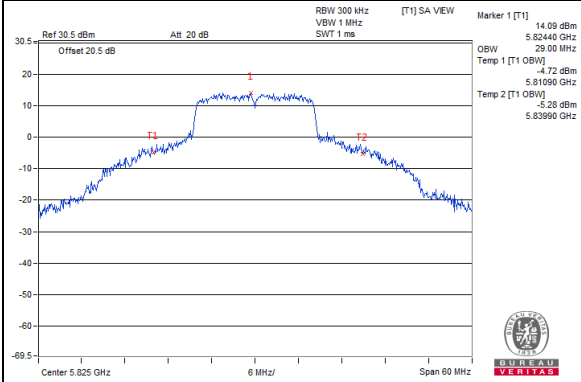

802.11n (20MHz)_Chain0 / CH165

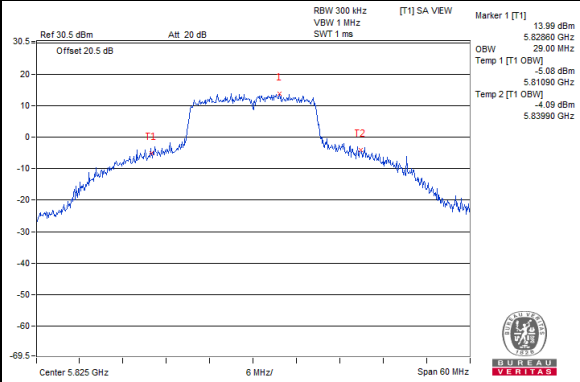

802.11n (40MHz)_Chain0 / CH151

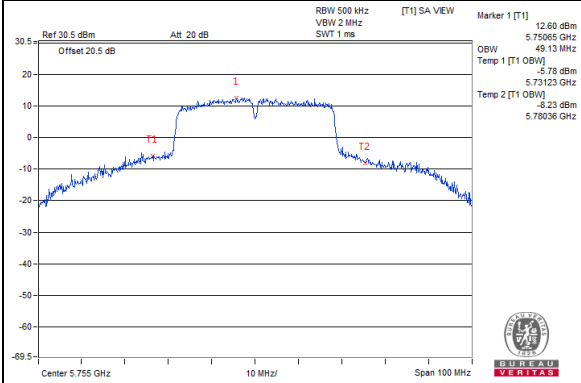

802.11ac (80MHz)_Chain1 / CH155

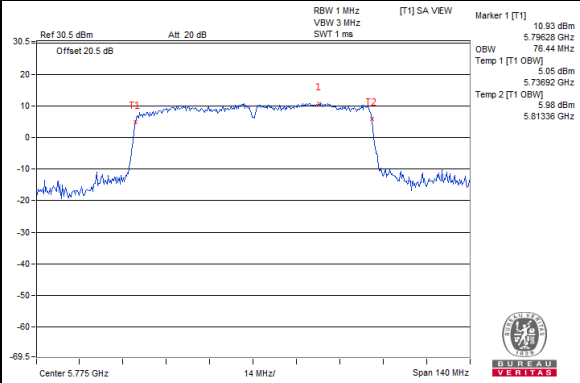

4.5 Peak Power Spectral Density Measurement

4.5.1 Limits of Peak Power Spectral Density Measurement

Operation Band	EUT Category		Limit
U-NII-1		Outdoor Access Point	17dBm/ MHz
		Fixed point-to-point Access Point	
	√	Indoor Access Point	
		Mobile and Portable client device	11dBm/ MHz
U-NII-2A	---		11dBm/ MHz
U-NII-2C	---		11dBm/ MHz
U-NII-3	√		30dBm/ 500kHz

4.5.2 Test Setup

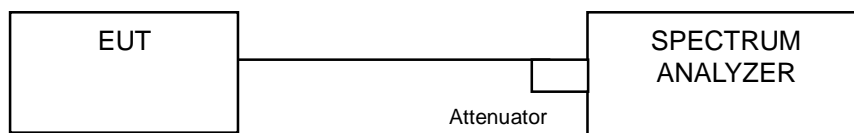

4.5.3 Test Instruments

Refer to section 4.1.2 to get information of above instrument.

4.5.4 Test Procedure

For U-NII-1 band:

Using method SA-2

1. Set span to encompass the entire emission bandwidth (EBW) of the signal.
2. Set RBW = 1 MHz, Set VBW ≥ 3 MHz, Detector = RMS
3. Sweep time = auto, trigger set to "free run".
4. Trace average at least 100 traces in power averaging mode.
5. Record the max value and add 10 log (1/duty cycle)

For U-NII-3 band:

1. Set span to encompass the entire emission bandwidth (EBW) of the signal.
2. Set RBW = 500 kHz, Set VBW ≥ 3 RBW, Detector = RMS
3. Sweep time = auto, trigger set to "free run".
4. Trace average at least 100 traces in power averaging mode.
5. Record the max value and add 10 log (1/duty cycle)

4.5.5 Deviation from Test Standard

No deviation.

4.5.6 EUT Operating Condition

Same as Item 4.3.6.

4.5.7 Test Results

Mode A

CDD MODE

For U-NII-1

802.11a

Chan.	Chan. Freq. (MHz)	PSD W/O Duty Factor (dBm)		Duty Factor (dB)	Total PSD With Duty Factor (dBm)	MAX. Limit (dBm)	Pass / Fail
		Chain 0	Chain 1				
36	5180	8.24	8.23	0.28	11.53	17.00	Pass
40	5200	10.78	10.85	0.28	14.11	17.00	Pass
48	5240	10.50	10.37	0.28	13.73	17.00	Pass

- Note:**
- Method a) of power density measurement of KDB 662911 is using for calculating total power density. Total power density is summing entire spectra across corresponding frequency bins on the various outputs by computer.
 - Directional gain = $1.38\text{dBi} + 10\log(2) = 4.39\text{dBi} < 6\text{dBi}$, so the power spectral density limit is not reduced.
 - Refer to section 3.3 for duty cycle spectrum plot.

802.11n (20MHz)

Chan.	Chan. Freq. (MHz)	PSD W/O Duty Factor (dBm)		Duty Factor (dB)	Total PSD With Duty Factor (dBm)	MAX. Limit (dBm)	Pass / Fail
		Chain 0	Chain 1				
36	5180	6.68	6.69	0.14	9.84	17.00	Pass
40	5200	9.96	10.16	0.14	13.21	17.00	Pass
48	5240	9.95	9.97	0.14	13.11	17.00	Pass

- Note:**
- Method a) of power density measurement of KDB 662911 is using for calculating total power density. Total power density is summing entire spectra across corresponding frequency bins on the various outputs by computer.
 - Directional gain = $1.38\text{dBi} + 10\log(2) = 4.39\text{dBi} < 6\text{dBi}$, so the power spectral density limit is not reduced.
 - Refer to section 3.3 for duty cycle spectrum plot.

802.11n (40MHz)

Chan.	Chan. Freq. (MHz)	PSD W/O Duty Factor (dBm)		Duty Factor (dB)	Total PSD With Duty Factor (dBm)	MAX. Limit (dBm)	Pass / Fail
		Chain 0	Chain 1				
38	5190	2.79	2.73	0.23	6.00	17.00	Pass
46	5230	6.96	7.02	0.23	10.23	17.00	Pass

- Note:**
- Method a) of power density measurement of KDB 662911 is using for calculating total power density. Total power density is summing entire spectra across corresponding frequency bins on the various outputs by computer.
 - Directional gain = $1.38\text{dBi} + 10\log(2) = 4.39\text{dBi} < 6\text{dBi}$, so the power spectral density limit is not reduced.
 - Refer to section 3.3 for duty cycle spectrum plot.

802.11ac (80MHz)

Chan.	Chan. Freq. (MHz)	PSD W/O Duty Factor (dBm)		Duty Factor (dB)	Total PSD With Duty Factor (dBm)	MAX. Limit (dBm)	Pass / Fail
		Chain 0	Chain 1				
42	5210	-0.96	-0.87	0.41	2.51	17.00	Pass

- Note:**
- Method a) of power density measurement of KDB 662911 is using for calculating total power density. Total power density is summing entire spectra across corresponding frequency bins on the various outputs by computer.
 - Directional gain = $1.38\text{dBi} + 10\log(2) = 4.39\text{dBi} < 6\text{dBi}$, so the power spectral density limit is not reduced.
 - Refer to section 3.3 for duty cycle spectrum plot.

Spectrum Plot of Worst Value

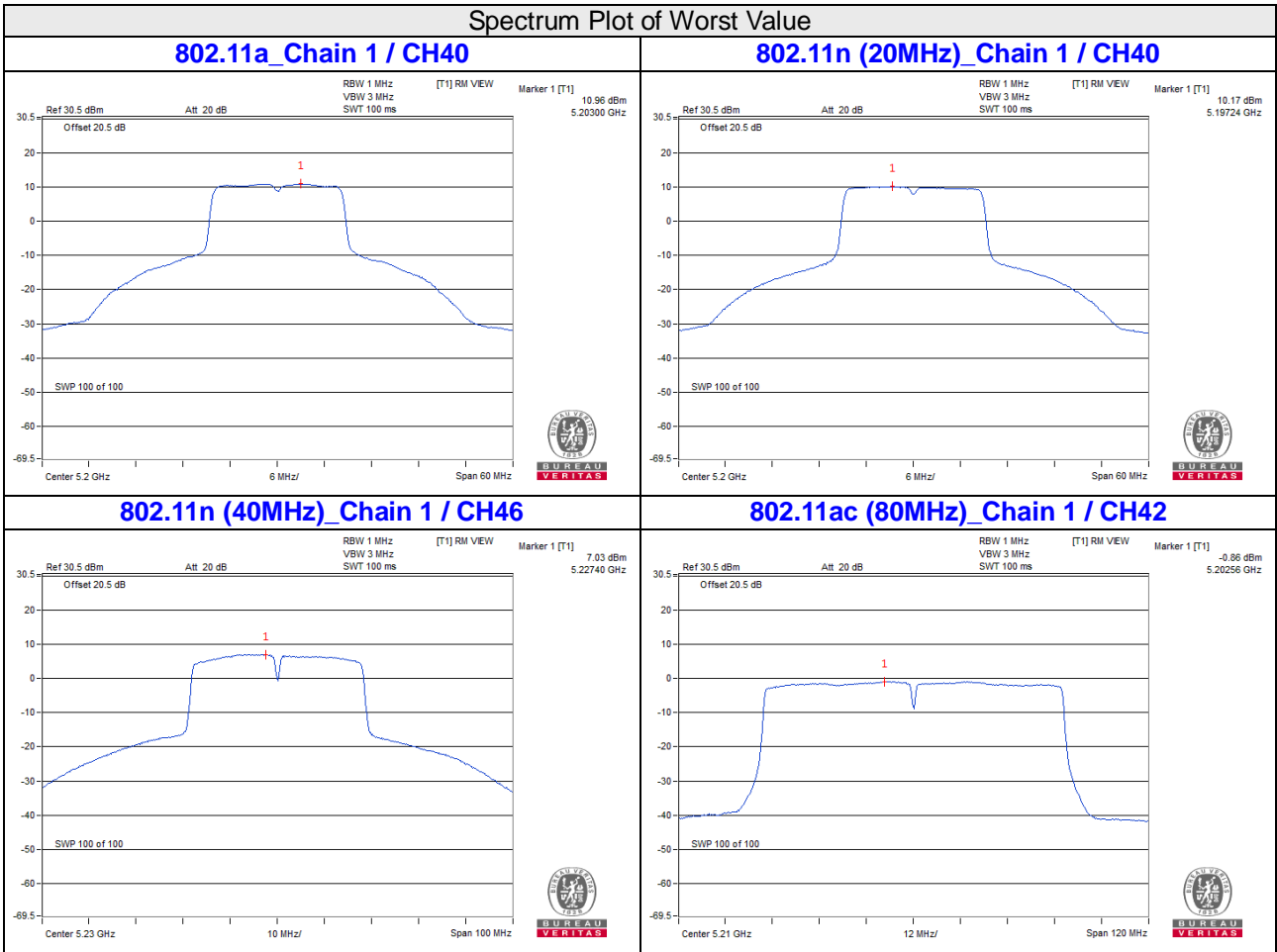

For U-NII-3:

802.11a

TX chain	Chan.	Chan. Freq. (MHz)	PSD W/O Duty Factor	10 log (N=2) dB	Duty Factor (dB)	Total PSD With Duty Factor (dBm/500kHz)	Limit (dBm/500kHz)	Pass /Fail
			(dBm/500kHz)					
0	149	5745	16.70	3.01	0.28	19.99	30.00	Pass
	157	5785	16.88	3.01	0.28	20.17	30.00	Pass
	165	5825	17.45	3.01	0.28	20.74	30.00	Pass
1	149	5745	16.68	3.01	0.28	19.97	30.00	Pass
	157	5785	16.87	3.01	0.28	20.16	30.00	Pass
	165	5825	17.23	3.01	0.28	20.52	30.00	Pass

Note: 1. Directional gain = $1.38\text{dBi} + 10\log(2) = 4.39\text{dBi} < 6\text{dBi}$, so the power spectral density limit is not reduced.

2. Refer to section 3.3 for duty cycle spectrum plot.

802.11n (20MHz)

TX chain	Chan.	Chan. Freq. (MHz)	PSD W/O Duty Factor	10 log (N=2) dB	Duty Factor (dB)	Total PSD With Duty Factor (dBm/500kHz)	Limit (dBm/500kHz)	Pass /Fail
			(dBm/500kHz)					
0	149	5745	17.09	3.01	0.14	20.24	30.00	Pass
	157	5785	16.93	3.01	0.14	20.08	30.00	Pass
	165	5825	17.49	3.01	0.14	20.64	30.00	Pass
1	149	5745	16.92	3.01	0.14	20.07	30.00	Pass
	157	5785	16.74	3.01	0.14	19.89	30.00	Pass
	165	5825	17.71	3.01	0.14	20.86	30.00	Pass

Note: 1. Directional gain = $1.38\text{dBi} + 10\log(2) = 4.39\text{dBi} < 6\text{dBi}$, so the power spectral density limit is not reduced.

2. Refer to section 3.3 for duty cycle spectrum plot.

802.11n (40MHz)

TX chain	Chan.	Chan. Freq. (MHz)	PSD W/O Duty Factor	10 log (N=2) dB	Duty Factor (dB)	Total PSD With Duty Factor (dBm/500kHz)	Limit (dBm/500kHz)	Pass /Fail
			(dBm/500kHz)					
0	151	5755	13.31	3.01	0.23	16.55	30.00	Pass
	159	5795	13.66	3.01	0.23	16.90	30.00	Pass
1	151	5755	13.25	3.01	0.23	16.49	30.00	Pass
	159	5795	13.04	3.01	0.23	16.28	30.00	Pass

Note: 1. Directional gain = $1.38\text{dBi} + 10\log(2) = 4.39\text{dBi} < 6\text{dBi}$, so the power spectral density limit is not reduced.

2. Refer to section 3.3 for duty cycle spectrum plot.

802.11ac (80MHz)

TX chain	Chan.	Chan. Freq. (MHz)	PSD W/O Duty Factor	10 log (N=2) dB	Duty Factor (dB)	Total PSD With Duty Factor (dBm/500kHz)	Limit (dBm/500kHz)	Pass /Fail
			(dBm/500kHz)					
0	155	5775	8.29	3.01	0.41	11.71	30.00	Pass
1	155	5775	8.74	3.01	0.41	12.16	30.00	Pass

Note: 1. Directional gain = $1.38\text{dBi} + 10\log(2) = 4.39\text{dBi} < 6\text{dBi}$, so the power spectral density limit is not reduced.

2. Refer to section 3.3 for duty cycle spectrum plot.

Spectrum Plot of Worst Value

802.11a_Chain 0 / CH165

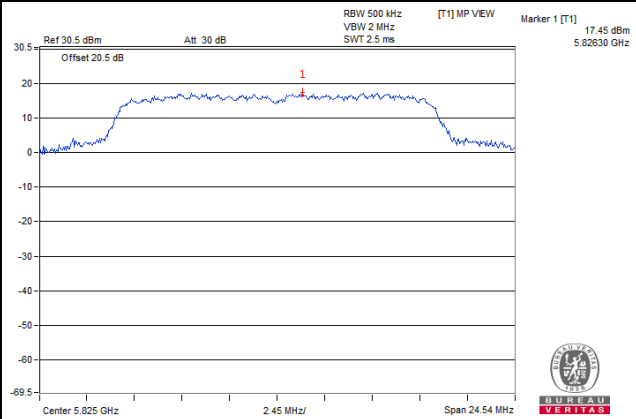

802.11n (20MHz)_Chain 1 / CH165

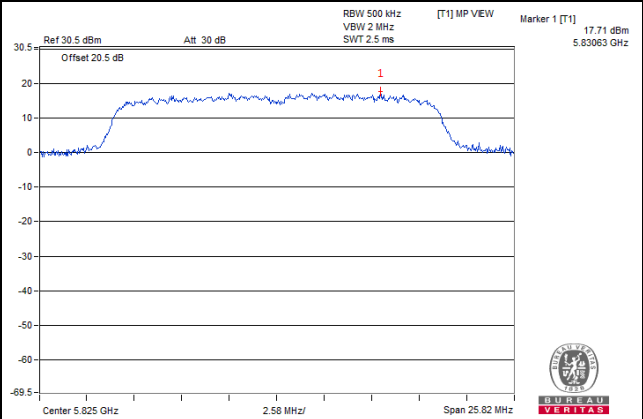

802.11n (40MHz)_Chain 0 / CH159

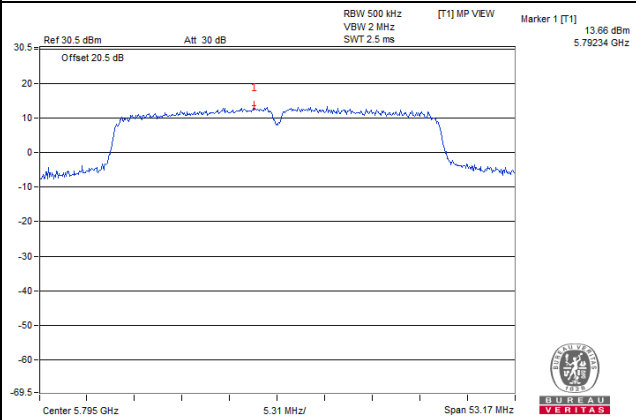

802.11ac (80MHz)_Chain 1 / CH155

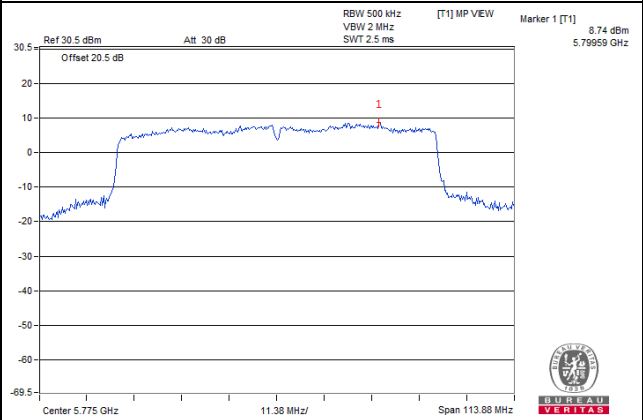

4.6 Frequency Stability Measurement

4.6.1 Limits of Frequency Stability Measurement

The frequency of the carrier signal shall be maintained within band of operation

4.6.2 Test Setup

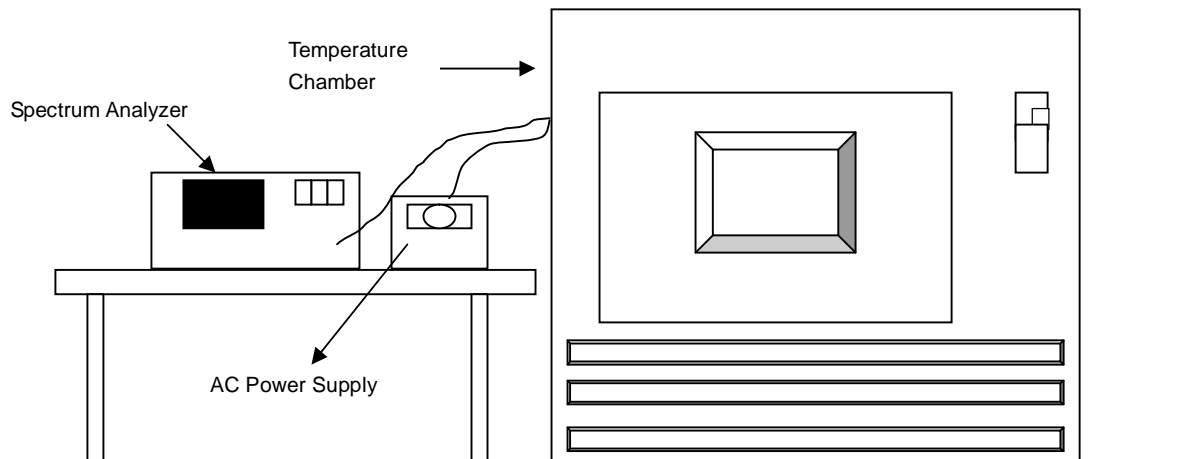

4.6.3 Test Instruments

Refer to section 4.1.2 to get information of above instrument.

4.6.4 Test Procedure

- The EUT was placed inside the environmental test chamber and powered by nominal AC voltage.
- Turn the EUT on and couple its output to a spectrum analyzer.
- Turn the EUT off and set the chamber to the highest temperature specified.
- Allow sufficient time (approximately 30 min) for the temperature of the chamber to stabilize, turn the EUT on and measure the operating frequency after 2, 5, and 10 Minutes.
- Repeat step 2 and 3 with the temperature chamber set to the lowest temperature.
- The test chamber was allowed to stabilize at +20 degree C for a minimum of 30 Minutes. The supply voltage was then adjusted on the EUT from 85% to 115% and the frequency record.

4.6.5 Deviation from Test Standard

No deviation.

4.6.6 EUT Operating Condition

Set the EUT transmit at un-modulation mode to test frequency stability.

4.6.7 Test Results

Mode A

CDD MODE

Frequency Stability Versus Temp.									
Operating Frequency: 5180 MHz									
TEMP. (°C)	Power Supply (Vac)	0 Minute		2 Minute		5 Minute		10 Minute	
		Measured Frequency (MHz)	Pass/Fail	Measured Frequency (MHz)	Pass/Fail	Measured Frequency (MHz)	Pass/Fail	Measured Frequency (MHz)	Pass/Fail
50	120	5180.043826	Pass	5180.043911	Pass	5180.043700	Pass	5180.043714	Pass
40	120	5180.042116	Pass	5180.042182	Pass	5180.042162	Pass	5180.042398	Pass
30	120	5180.043298	Pass	5180.043115	Pass	5180.043087	Pass	5180.043299	Pass
20	120	5180.042991	Pass	5180.043533	Pass	5180.043285	Pass	5180.043196	Pass
10	120	5180.0428	Pass	5180.042683	Pass	5180.042800	Pass	5180.042886	Pass
0	120	5180.043134	Pass	5180.043014	Pass	5180.042974	Pass	5180.043162	Pass
-10	120	5180.043125	Pass	5180.043115	Pass	5180.043523	Pass	5180.043523	Pass
-20	120	5180.043865	Pass	5180.042453	Pass	5180.043360	Pass	5180.042902	Pass

Frequency Stability Versus Voltage									
Operating Frequency: 5180 MHz									
TEMP. (°C)	Power Supply (Vac)	0 Minute		2 Minute		5 Minute		10 Minute	
		Measured Frequency (MHz)	Pass/Fail	Measured Frequency (MHz)	Pass/Fail	Measured Frequency (MHz)	Pass/Fail	Measured Frequency (MHz)	Pass/Fail
20	138	5180.043326	Pass	5180.043147	Pass	5180.043213	Pass	5180.043392	Pass
	120	5180.042991	Pass	5180.043533	Pass	5180.043285	Pass	5180.043196	Pass
	102	5180.042332	Pass	5180.041958	Pass	5180.042304	Pass	5180.042086	Pass

4.7 6dB Bandwidth Measurement

4.7.1 Limits of 6dB Bandwidth Measurement

The minimum of 6dB Bandwidth Measurement is 0.5MHz.

4.7.2 Test Setup

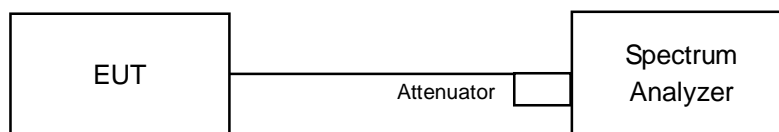

4.7.3 Test Instruments

Refer to section 4.1.2 to get information of above instrument.

4.7.4 Test Procedure

MEASUREMENT PROCEDURE REF

- Set resolution bandwidth (RBW) = 100kHz
- Set the video bandwidth (VBW) $\geq 3 \times$ RBW, Detector = Peak.
- Trace mode = max hold.
- Sweep = auto couple.
- Measure the maximum width of the emission that is constrained by the frequencies associated with the two amplitude points (upper and lower) that are attenuated by 6 dB relative to the maximum level measured in the fundamental emission

4.7.5 Deviation from Test Standard

No deviation.

4.7.6 EUT Operating Condition

The software provided by client to enable the EUT under transmission condition continuously at lowest, middle and highest channel frequencies individually.

4.7.7 Test Results

Mode A

CDD MODE

802.11a

Channel	Frequency (MHz)	6dB Bandwidth (MHz)		Minimum Limit (MHz)	Pass / Fail
		Chain 0	Chain 1		
149	5745	16.33	16.35	0.5	PASS
157	5785	16.31	16.09	0.5	PASS
165	5825	16.36	16.35	0.5	PASS

802.11n (20MHz)

Channel	Frequency (MHz)	6dB Bandwidth (MHz)		Minimum Limit (MHz)	Pass / Fail
		Chain 0	Chain 1		
149	5745	17.57	17.58	0.5	PASS
157	5785	17.18	17.29	0.5	PASS
165	5825	17.20	17.21	0.5	PASS

802.11n (40MHz)

Channel	Frequency (MHz)	6dB Bandwidth (MHz)		Minimum Limit (MHz)	Pass / Fail
		Chain 0	Chain 1		
151	5755	35.76	35.38	0.5	PASS
159	5795	35.44	36.36	0.5	PASS

802.11ac (80MHz)

Channel	Frequency (MHz)	6dB Bandwidth (MHz)		Minimum Limit (MHz)	Pass / Fail
		Chain 0	Chain 1		
155	5775	75.89	75.92	0.5	PASS

Spectrum Plot of Worst Value

802.11a_Chain 0 / CH165

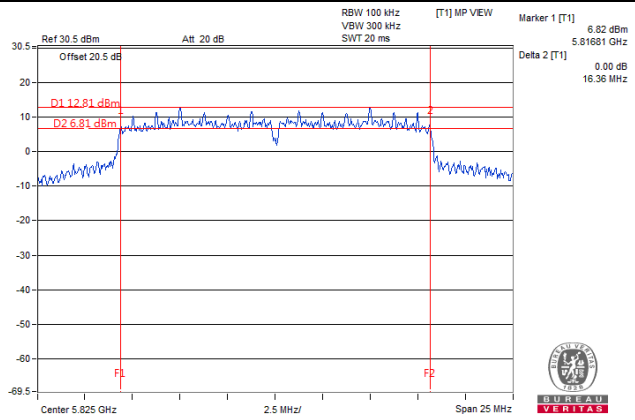

802.11n (20MHz)_Chain 1 / CH149

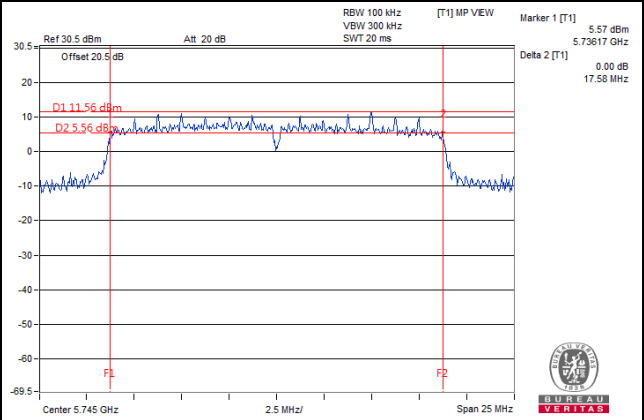

802.11n (40MHz)_Chain 1 / CH159

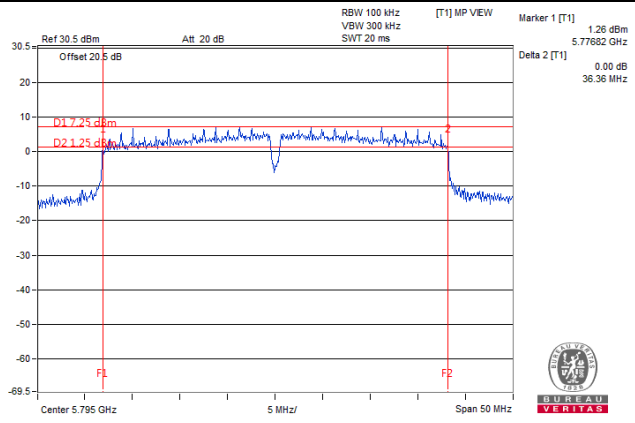

802.11ac (80MHz)_Chain 1 / CH155

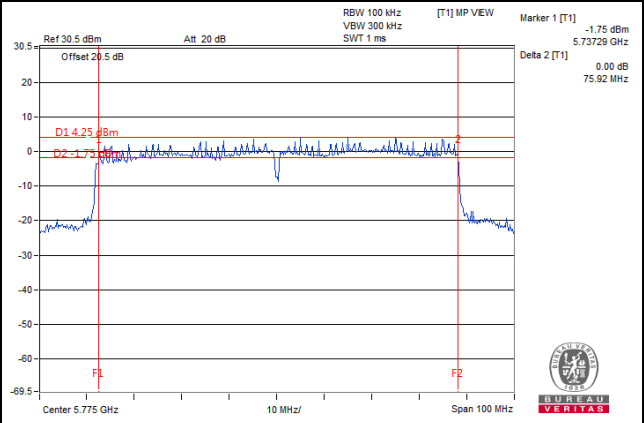

5 Pictures of Test Arrangements

Please refer to the attached file (Test Setup Photo).

Annex A- Radiated Out of Band Emission (OOBE) Measurement (For U-NII-3 band)

Mode A
CDD MODE

802.11a

CH 149 5745 MHz

Horizontal

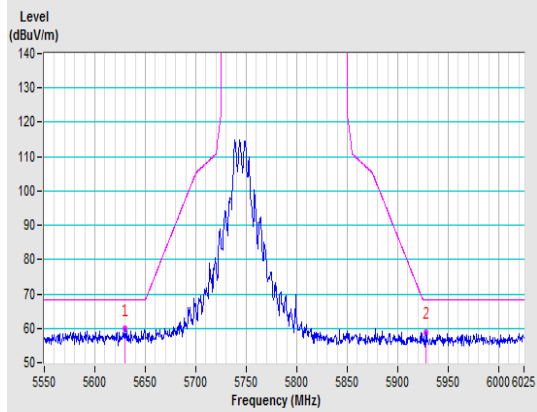

Vertical

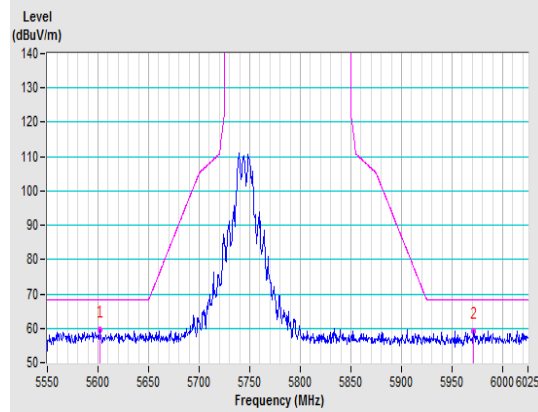

CH 157 5785 MHz

Horizontal

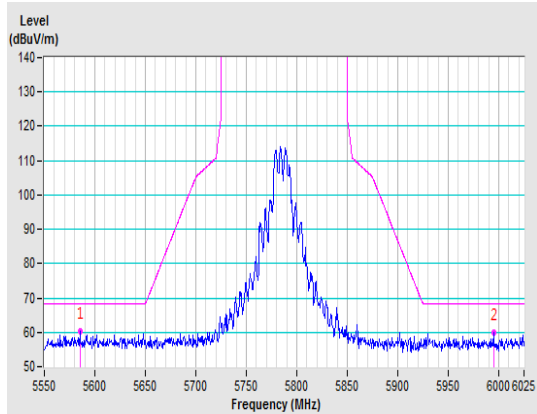

Vertical

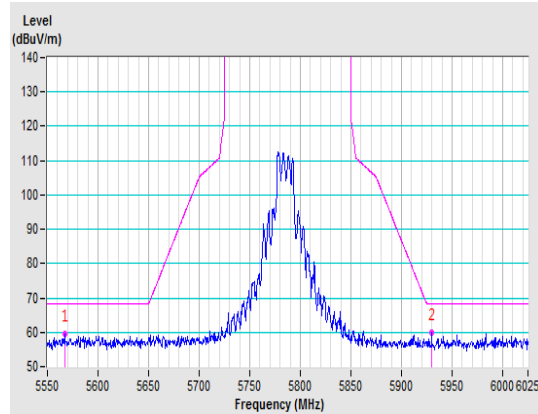

CH 165 5825 MHz

Horizontal

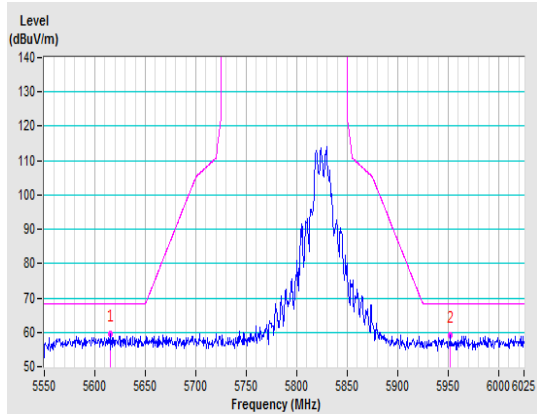

Vertical

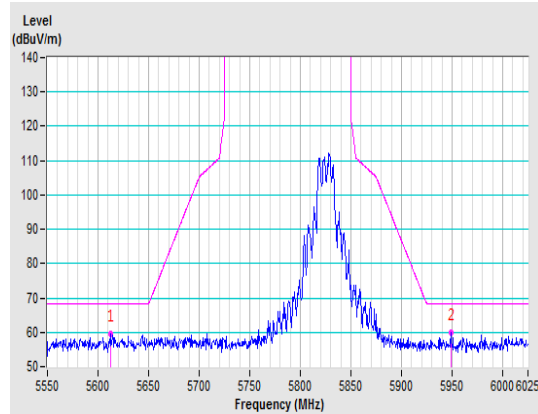

802.11n (20MHz)

CH 149 5745 MHz

Horizontal

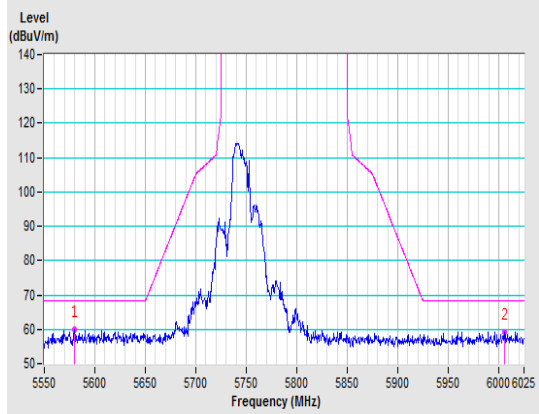

Vertical

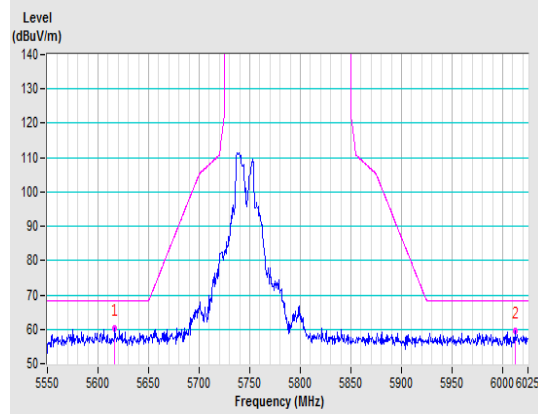

CH 157 5785 MHz

Horizontal

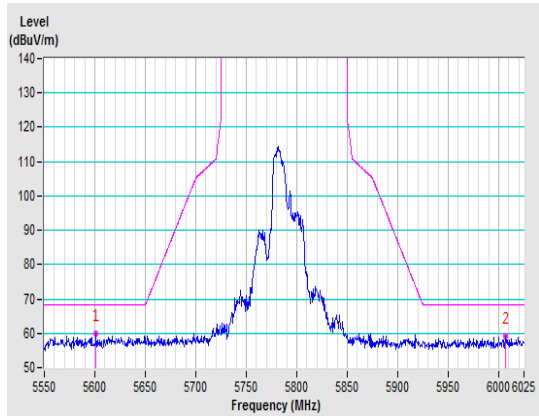

Vertical

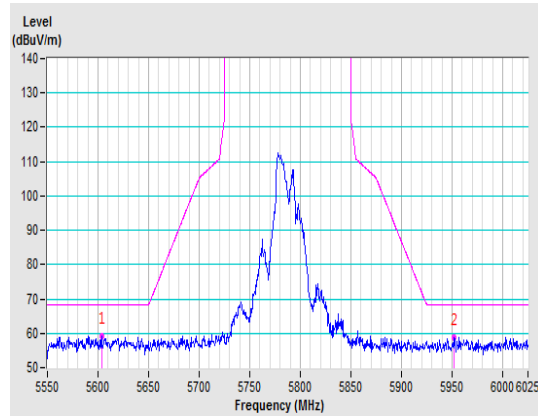

CH 165 5825 MHz

Horizontal

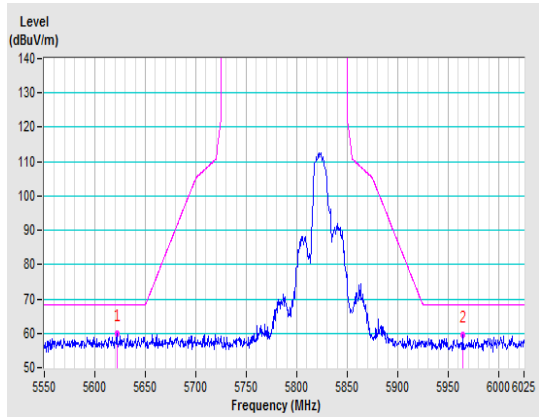

Vertical

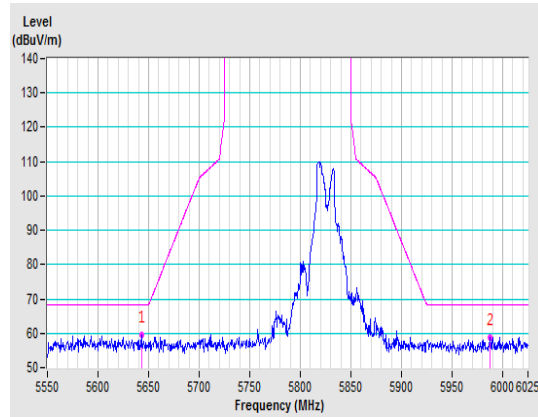

802.11n (40MHz)

CH 151 5755 MHz

Horizontal

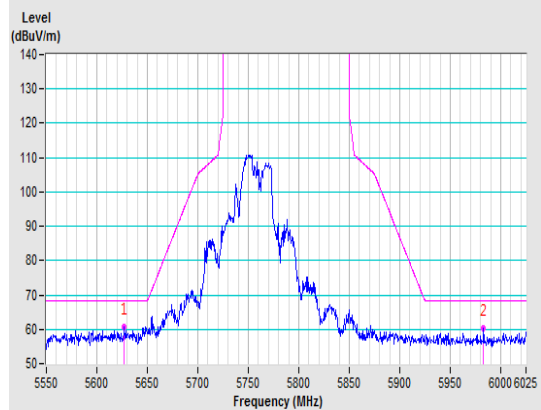

Vertical

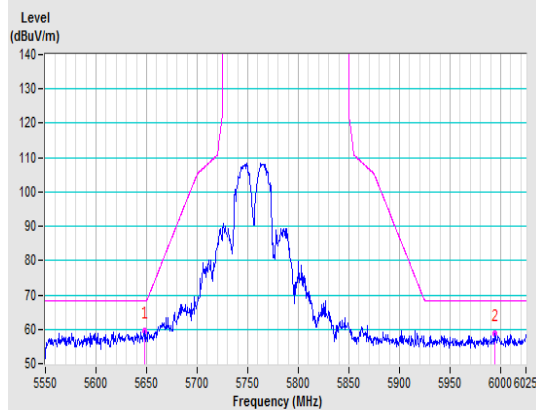

CH 159 5795 MHz

Horizontal

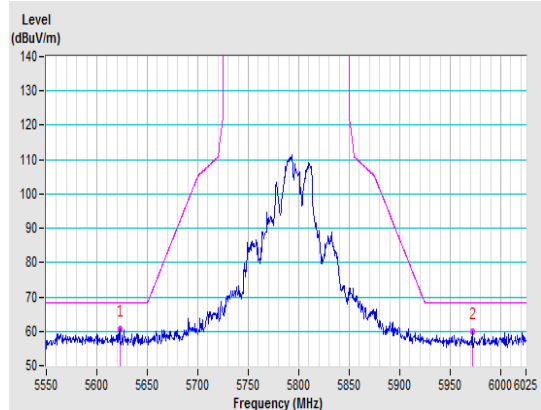

Vertical

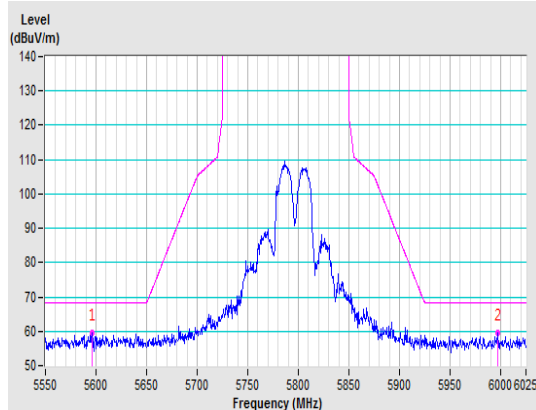

802.11ac (80MHz)

CH 155 5775 MHz

Horizontal

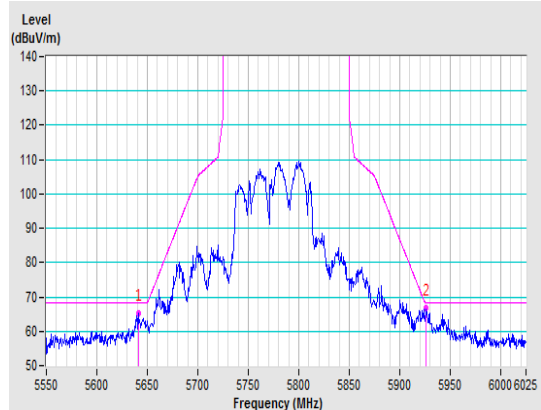

Vertical

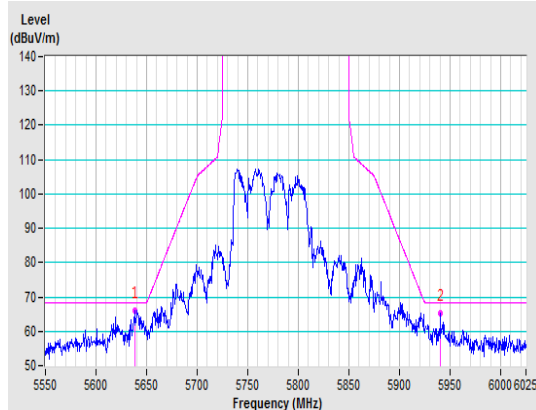

Appendix – Information on the Testing Laboratories

We, Bureau Veritas Consumer Products Services (H.K.) Ltd., Taoyuan Branch, were founded in 1988 to provide our best service in EMC, Radio, Telecom and Safety consultation. Our laboratories are accredited and approved according to ISO/IEC 17025.

If you have any comments, please feel free to contact us at the following:

Linko EMC/RF Lab

Tel: 886-2-26052180

Fax: 886-2-26051924

Hsin Chu EMC/RF/Telecom Lab

Tel: 886-3-6668565

Fax: 886-3-6668323

Hwa Ya EMC/RF/Safety Lab

Tel: 886-3-3183232

Fax: 886-3-3270892

Email: service.adt@tw.bureauveritas.com

Web Site: www.bureauveritas-adt.com

The address and road map of all our labs can be found in our web site also.

--- END ---