



A D T

# FCC TEST REPORT (15.247)

**REPORT NO.:** RF140423C02

**MODEL NO.:** EAP767

**FCC ID:** VZ9140001

**RECEIVED:** Apr. 23, 2014

**TESTED:** Apr. 29, 2014 ~ May 08, 2014

**ISSUED:** May 21, 2014

**APPLICANT:** 4IPNET, INC.

**ADDRESS:** 3F-3, No. 369, Fusing N. Rd., Taipei 105, Taiwan,  
R.O.C.

**ISSUED BY:** Bureau Veritas Consumer Products Services  
(H.K.) Ltd., Taoyuan Branch

**LAB ADDRESS:** No. 47, 14th Ling, Chia Pau Vil., Lin Kou Dist.,  
New Taipei City, Taiwan ( R.O.C )

**TEST LOCATION:** No. 19, Hwa Ya 2nd Rd, Wen Hwa Tsuen, Kwei  
Shan Hsiang, Taoyuan Hsien 333, Taiwan, R.O.C.

This report should not be used by the client to claim product certification, approval, or endorsement by TAF or any government agencies.



This report is for your exclusive use. Any copying or replication of this report to or for any other person or entity, or use of our name or trademark, is permitted only with our prior written permission. This report sets forth our findings solely with respect to the test samples identified herein. The results set forth in this report are not indicative or representative of the quality or characteristics of the lot from which a test sample was taken or any similar or identical product unless specifically and expressly noted. Our report includes all of the tests requested by you and the results thereof based upon the information that you provided to us. You have 60 days from date of issuance of this report to notify us of any material error or omission caused by our negligence, provided, however, that such notice shall be in writing and shall specifically address the issue you wish to raise. A failure to raise such issue within the prescribed time shall constitute your unqualified acceptance of the completeness of this report, the tests conducted and the correctness of the report contents. Unless specific mention, the uncertainty of measurement has been explicitly taken into account to declare the compliance or non-compliance to the specification.



# TABLE OF CONTENTS

- RELEASE CONTROL RECORD .....5
- 1. CERTIFICATION.....6
- 2. SUMMARY OF TEST RESULTS .....7
  - 2.1 MEASUREMENT UNCERTAINTY.....7
- 3. GENERAL INFORMATION .....8
  - 3.1 GENERAL DESCRIPTION OF EUT .....8
  - 3.2 DESCRIPTION OF TEST MODES ..... 10
    - 3.2.1 TEST MODE APPLICABILITY AND TESTED CHANNEL DETAIL ..... 11
  - 3.3 DESCRIPTION OF SUPPORT UNITS ..... 15
    - 3.3.1 CONFIGURATION OF SYSTEM UNDER TEST ..... 15
  - 3.4 DUTY CYCLE TEST SIGNAL ..... 17
  - 3.5 GENERAL DESCRIPTION OF APPLIED STANDARDS ..... 22
- 4. TEST TYPES AND RESULTS (FOR 2.4GHz BAND) ..... 23
  - 4.1 RADIATED EMISSION AND BANDEDGE MEASUREMENT ..... 23
    - 4.1.1 LIMITS OF RADIATED EMISSION AND BANDEDGE MEASUREMENT ..... 23
    - 4.1.2 TEST INSTRUMENTS ..... 24
    - 4.1.3 TEST PROCEDURES ..... 25
    - 4.1.4 DEVIATION FROM TEST STANDARD ..... 25
    - 4.1.5 TEST SETUP ..... 26
    - 4.1.6 EUT OPERATING CONDITIONS ..... 27
    - 4.1.7 TEST RESULTS..... 28
  - 4.2 CONDUCTED EMISSION MEASUREMENT ..... 49
    - 4.2.1 LIMITS OF CONDUCTED EMISSION MEASUREMENT ..... 49
    - 4.2.2 TEST INSTRUMENTS ..... 49
    - 4.2.3 TEST PROCEDURES ..... 50
    - 4.2.4 DEVIATION FROM TEST STANDARD ..... 50
    - 4.2.5 TEST SETUP ..... 51
    - 4.2.6 EUT OPERATING CONDITIONS ..... 51
    - 4.2.7 TEST RESULTS..... 52
  - 4.3 6dB BANDWIDTH MEASUREMENT ..... 56
    - 4.3.1 LIMITS OF 6dB BANDWIDTH MEASUREMENT ..... 56
    - 4.3.2 TEST SETUP ..... 56
    - 4.3.3 TEST INSTRUMENTS ..... 56
    - 4.3.4 TEST PROCEDURE ..... 56
    - 4.3.5 DEVIATION FROM TEST STANDARD ..... 56
    - 4.3.6 EUT OPERATING CONDITIONS ..... 56
    - 4.3.7 TEST RESULTS..... 57
  - 4.4 CONDUCTED OUTPUT POWER ..... 61
    - 4.4.1 LIMITS OF CONDUCTED OUTPUT POWER MEASUREMENT ..... 61
    - 4.4.2 TEST SETUP ..... 61
    - 4.4.3 TEST INSTRUMENTS ..... 61
    - 4.4.4 TEST PROCEDURES ..... 61
    - 4.4.5 DEVIATION FROM TEST STANDARD ..... 61
    - 4.4.6 EUT OPERATING CONDITIONS ..... 61
    - 4.4.7 TEST RESULTS..... 62
  - 4.5 POWER SPECTRAL DENSITY MEASUREMENT ..... 65
    - 4.5.1 LIMITS OF POWER SPECTRAL DENSITY MEASUREMENT ..... 65
    - 4.5.2 TEST SETUP ..... 65
    - 4.5.3 TEST INSTRUMENTS ..... 65
    - 4.5.4 TEST PROCEDURE ..... 65
    - 4.5.5 DEVIATION FROM TEST STANDARD ..... 65
    - 4.5.6 EUT OPERATING CONDITION..... 65



- 4.5.7 TEST RESULTS..... 66
- 4.6 CONDUCTED OUT OF BAND EMISSION MEASUREMENT ..... 70
  - 4.6.1 LIMITS OF CONDUCTED OUT OF BAND EMISSION MEASUREMENT ..... 70
  - 4.6.2 TEST SETUP ..... 70
  - 4.6.3 TEST INSTRUMENTS ..... 70
  - 4.6.4 TEST PROCEDURE ..... 70
  - 4.6.5 DEVIATION FROM TEST STANDARD ..... 70
  - 4.6.6 EUT OPERATING CONDITION..... 70
  - 4.6.7 TEST RESULTS..... 71
- 5. TEST TYPES AND RESULTS (FOR 5.0GHz BAND) ..... 85
  - 5.1 RADIATED EMISSION AND BANDEDGE MEASUREMENT ..... 85
    - 5.1.1 LIMITS OF RADIATED EMISSION AND BANDEDGE MEASUREMENT ..... 85
    - 5.1.2 TEST INSTRUMENTS..... 86
    - 5.1.3 TEST PROCEDURES ..... 86
    - 5.1.4 DEVIATION FROM TEST STANDARD ..... 86
    - 5.1.5 TEST SETUP ..... 86
    - 5.1.6 EUT OPERATING CONDITIONS ..... 86
    - 5.1.7 TEST RESULTS..... 87
  - 5.2 CONDUCTED EMISSION MEASUREMENT ..... 104
    - 5.2.1 LIMITS OF CONDUCTED EMISSION MEASUREMENT ..... 104
    - 5.2.2 TEST INSTRUMENTS ..... 104
    - 5.2.3 TEST PROCEDURES ..... 104
    - 5.2.4 DEVIATION FROM TEST STANDARD ..... 104
    - 5.2.5 TEST SETUP ..... 104
    - 5.2.6 EUT OPERATING CONDITIONS ..... 104
    - 5.2.7 TEST RESULTS..... 105
  - 5.3 6dB BANDWIDTH MEASUREMENT ..... 109
    - 5.3.1 LIMITS OF 6dB BANDWIDTH MEASUREMENT ..... 109
    - 5.3.2 TEST SETUP ..... 109
    - 5.3.3 TEST INSTRUMENTS..... 109
    - 5.3.4 TEST PROCEDURE ..... 109
    - 5.3.5 DEVIATION FROM TEST STANDARD ..... 109
    - 5.3.6 EUT OPERATING CONDITIONS ..... 109
    - 5.3.7 TEST RESULTS..... 110
  - 5.4 MAXIMUM OUTPUT POWER ..... 114
    - 5.4.1 LIMITS OF MAXIMUM OUTPUT POWER MEASUREMENT ..... 114
    - 5.4.2 TEST SETUP ..... 114
    - 5.4.3 INSTRUMENTS ..... 114
    - 5.4.4 TEST PROCEDURES ..... 114
    - 5.4.5 DEVIATION FROM TEST STANDARD ..... 114
    - 5.4.6 EUT OPERATING CONDITIONS ..... 114
    - 5.4.7 TEST RESULTS..... 115
  - 5.5 POWER SPECTRAL DENSITY MEASUREMENT..... 117
    - 5.5.1 LIMITS OF POWER SPECTRAL DENSITY MEASUREMENT ..... 117
    - 5.5.2 TEST SETUP ..... 117
    - 5.5.3 TEST INSTRUMENTS..... 117
    - 5.5.4 TEST PROCEDURE ..... 117
    - 5.5.5 DEVIATION FROM TEST STANDARD ..... 117
    - 5.5.6 EUT OPERATING CONDITION..... 117
    - 5.5.7 TEST RESULTS..... 118
  - 5.6 CONDUCTED OUT OF BAND EMISSION MEASUREMENT ..... 123
    - 5.6.1 LIMITS OF OUT OF BAND EMISSION MEASUREMENT ..... 123
    - 5.6.2 TEST SETUP ..... 123
    - 5.6.3 TEST INSTRUMENTS..... 123
    - 5.6.4 TEST PROCEDURE ..... 123



A D T

5.6.5	DEVIATION FROM TEST STANDARD .....	123
5.6.6	EUT OPERATING CONDITION.....	123
5.6.7	TEST RESULTS.....	123
6.	PHOTOGRAPHS OF THE TEST CONFIGURATION.....	139
7.	INFORMATION ON THE TESTING LABORATORIES .....	140
8.	APPENDIX A – MODIFICATIONS RECORDERS FOR ENGINEERING CHANGES TO THE EUT BY THE LAB .....	141



A D T

## RELEASE CONTROL RECORD

ISSUE NO.	REASON FOR CHANGE	DATE ISSUED
RF140423C02	Original release	May 21, 2014



## 1. CERTIFICATION

**PRODUCT:** Enterprise Access Point  
**MODEL NO.:** EAP767  
**BRAND:** 4ipnet  
**APPLICANT:** 4IPNET, INC.  
**TESTED:** Apr. 29, 2014 ~ May 08, 2014  
**TEST SAMPLE:** Production Unit  
**STANDARDS:** **FCC Part 15, Subpart C (Section 15.247)**  
ANSI C63.10-2009

The above equipment (model: EAP767) has been tested by **Bureau Veritas Consumer Products Services (H.K.) Ltd., Taoyuan Branch**, and found compliance with the requirement of the above standards. The test record, data evaluation & Equipment Under Test (EUT) configurations represented herein are true and accurate accounts of the measurements of the sample's EMC characteristics under the conditions specified in this report.

**PREPARED BY** : Evonne Liu , **DATE** : May 21, 2014  
Evonne Liu / Specialist

**APPROVED BY** : Sam Chen , **DATE** : May 21, 2014  
Sam Chen / Senior Project Engineer

## 2. SUMMARY OF TEST RESULTS

The EUT has been tested according to the following specifications:

APPLIED STANDARD: FCC PART 15, SUBPART C (SECTION 15.247)			
STANDARD SECTION	TEST TYPE	RESULT	REMARK
15.207	AC Power Conducted Emission	PASS	Meet the requirement of limit. Minimum passing margin is -7.10dB at 0.15391MHz.
15.205 & 15.209	Radiated Emissions	PASS	Meet the requirement of limit. Minimum passing margin is -0.94dB at 2483.5MHz.
15.247(d)	Band Edge Measurement	PASS	Meet the requirement of limit.
15.247(d)	Antenna Port Emission	PASS	Meet the requirement of limit.
15.247(a)(2)	6dB bandwidth	PASS	Meet the requirement of limit.
15.247(b)	Conducted power	PASS	Meet the requirement of limit.
15.247(e)	Power Spectral Density	PASS	Meet the requirement of limit.
15.203	Antenna Requirement	PASS	No antenna connector is used.

### 2.1 MEASUREMENT UNCERTAINTY

Where relevant, the following measurement uncertainty levels have been estimated for tests performed on the EUT as specified in CISPR 16-4-2:

MEASUREMENT	FREQUENCY	UNCERTAINTY
Conducted emissions	9kHz~30MHz	2.44 dB
Radiated emissions	30MHz ~ 200MHz	2.93 dB
	200MHz ~1000MHz	2.95 dB
	1GHz ~ 18GHz	2.26 dB
	18GHz ~ 40GHz	1.94 dB

This uncertainty represents an expanded uncertainty expressed at approximately the 95% confidence level using a coverage factor of  $k = 2$ .



A D T

### 3. GENERAL INFORMATION

#### 3.1 GENERAL DESCRIPTION OF EUT

<b>EUT</b>	Enterprise Access Point
<b>MODEL NO.</b>	EAP767
<b>POWER SUPPLY</b>	12Vdc (adapter)
<b>MODULATION TYPE</b>	CCK, DQPSK, DBPSK for DSSS 256QAM, 64QAM, 16QAM, QPSK, BPSK for OFDM
<b>MODULATION TECHNOLOGY</b>	DSSS, OFDM
<b>TRANSFER RATE</b>	802.11b: 11.0 / 5.5 / 2.0 / 1.0 Mbps 802.11g: 54.0 / 48.0 / 36.0 / 24.0 / 18.0 / 12.0 / 9.0 / 6.0 Mbps 802.11a: 54.0 / 48.0 / 36.0 / 24.0 / 18.0 / 12.0 / 9.0 / 6.0 Mbps 802.11n: Up to 135Mbps 802.11ac: Up to V9
<b>OPERATING FREQUENCY</b>	<b>2.4GHz:</b> 2412 ~ 2462MHz <b>5.0GHz:</b> 5745 ~ 5825MHz
<b>NUMBER OF CHANNEL</b>	<b>2.4GHz:</b> 11 for 802.11b, 802.11g, 802.11n (20MHz) 7 for 802.11n (40MHz) <b>5.0GHz:</b> 4 for 802.11a, 802.11n (20MHz) 2 for 802.11n (40MHz) 1 for 802.11ac (80MHz)
<b>OUTPUT POWER</b>	959.127mW for 2412 ~ 2462MHz 829.961mW for 5745 ~ 5825MHz
<b>ANTENNA CONNECTOR</b>	NA
<b>DATA CABLE</b>	Refer to Note as below
<b>I/O PORTS</b>	Refer to user's manual
<b>ACCESSORY DEVICES</b>	Refer to Note as below

**NOTE:**

1. The antenna information is listed as below.

Antenna Type	Antenna Model	Band	Frequency Band	Tx Antenna	Antenna Gain
PCB	AP331AI	sercomm	2412 ~ 2462	1	4.28
				2	1.34
				3	2.54
			5745 ~ 5825	1	4.42
				2	4.5
				3	3.98





A D T

2. There're 2 configurations for the EUT listed as below.

Sample	Model	Power Supply
A	EAP767	from Adapter
B		from POE

3. The EUT contains following accessory devices.

ITEM	BRAND	MODEL	SPECIFICATION
Adapter	Asian	WA-30B12	I/P: 100-240Vac, 50-60Hz, 0.8A O/P: 12Vdc, 2.5A AC power code 1.5m

4. The EUT incorporates a MIMO function. Physically, the EUT provides 3 completed transmitters and 3 receivers.

MODULATION MODE	TX FUNCTION
802.11b	1TX
802.11g	1TX
802.11a	1TX
802.11n (20MHz)	1TX, 2TX, 3TX
802.11n (40MHz)	1TX, 2TX, 3TX
802.11ac (80MHz)	1TX, 2TX, 3TX

5. The above EUT information is declared by the manufacturer and for more detailed features description, please refer to the manufacturer's specifications or User's Manual.

### 3.2 DESCRIPTION OF TEST MODES

#### FOR 2.4GHz:

11 channels are provided for 802.11b, 802.11g and 802.11n (20MHz):

CHANNEL	FREQUENCY	CHANNEL	FREQUENCY
1	2412MHz	7	2442MHz
2	2417MHz	8	2447MHz
3	2422MHz	9	2452MHz
4	2427MHz	10	2457MHz
5	2432MHz	11	2462MHz
6	2437MHz		

7 channels are provided for 802.11n (40MHz):

CHANNEL	FREQUENCY	CHANNEL	FREQUENCY
3	2422MHz	7	2442MHz
4	2427MHz	8	2447MHz
5	2432MHz	9	2452MHz
6	2437MHz		

#### FOR 5.0GHz (5745 ~ 5825MHz):

5 channels are provided for 802.11a, 802.11n (20MHz):

CHANNEL	FREQUENCY	CHANNEL	FREQUENCY
149	5745MHz	157	5785MHz
153	5765MHz	165	5825MHz

2 channels are provided for 802.11n (40MHz):

CHANNEL	FREQUENCY	CHANNEL	FREQUENCY
151	5755MHz	159	5795MHz

1 channel is provided for 802.11ac (80MHz):

CHANNEL	FREQUENCY
155	5775MHz



### 3.2.1 TEST MODE APPLICABILITY AND TESTED CHANNEL DETAIL

#### WLAN 2.4GHz:

EUT CONFIGURE MODE	APPLICABLE TO				DESCRIPTION
	RE≥1G	RE<1G	PLC	APCM	
A	√	√	√	√	Sample A from Adapter
B	-	√	√	-	Sample B from POE

Where **RE≥1G**: Radiated Emission above 1GHz      **RE<1G**: Radiated Emission below 1GHz  
**PLC**: Power Line Conducted Emission      **APCM**: Antenna Port Conducted Measurement

**NOTE:** The EUT had been pre-tested on the positioned of each 3 axis. The worst case was found when positioned on **X-plane** and **Z-plane** for Sample A / **Z-plane** for Sample B.

#### RADIATED EMISSION TEST (ABOVE 1GHz):

- Pre-Scan has been conducted to determine the worst-case mode from all possible combinations between available modulations, data rates and antenna ports (if EUT with antenna diversity architecture).
- Following channel(s) was (were) selected for the final test as listed below.

EUT CONFIGURE MODE	MODE	AVAILABLE CHANNEL	TESTED CHANNEL	MODULATION TECHNOLOGY	MODULATION TYPE	DATA RATE (Mbps)
A	802.11b	1 to 11	1, 6, 11	DSSS	DBPSK	1.0
	802.11g	1 to 11	1, 6, 11	OFDM	BPSK	6.0
	802.11n (20MHz)	1 to 11	1, 6, 11	OFDM	BPSK	MCS0
	802.11n (40MHz)	3 to 9	3, 6, 9	OFDM	BPSK	MCS0

#### RADIATED EMISSION TEST (BELOW 1GHz):

- Pre-Scan has been conducted to determine the worst-case mode from all possible combinations between available modulations, data rates and antenna ports (if EUT with antenna diversity architecture).
- Following channel(s) was (were) selected for the final test as listed below.

EUT CONFIGURE MODE	MODE	AVAILABLE CHANNEL	TESTED CHANNEL	MODULATION TECHNOLOGY	MODULATION TYPE	DATA RATE (Mbps)
A, B	802.11n (40MHz)	3 to 9	6	OFDM	BPSK	MCS0



A D T

**POWER LINE CONDUCTED EMISSION TEST:**

EUT CONFIGURE MODE	MODE	AVAILABLE CHANNEL	TESTED CHANNEL	MODULATION TECHNOLOGY	MODULATION TYPE	DATA RATE (Mbps)
A, B	802.11n (40MHz)	3 to 9	6	OFDM	BPSK	MCS0

**BANDEDGE MEASUREMENT:**

Pre-Scan has been conducted to determine the worst-case mode from all possible combinations between available modulations, data rates and antenna ports (if EUT with antenna diversity architecture).

Following channel(s) was (were) selected for the final test as listed below.

EUT CONFIGURE MODE	MODE	AVAILABLE CHANNEL	TESTED CHANNEL	MODULATION TECHNOLOGY	MODULATION TYPE	DATA RATE (Mbps)
A	802.11b	1 to 11	1, 6, 11	DSSS	DBPSK	1.0
	802.11g	1 to 11	1, 6, 11	OFDM	BPSK	6.0
	802.11n (20MHz)	1 to 11	1, 6, 11	OFDM	BPSK	MCS0
	802.11n (40MHz)	3 to 9	3, 6, 9	OFDM	BPSK	MCS0

**ANTENNA PORT CONDUCTED MEASUREMENT:**

This item includes all test value of each mode, but only includes spectrum plot of worst value of each mode.

Pre-Scan has been conducted to determine the worst-case mode from all possible combinations between available modulations, data rates and antenna ports (if EUT with antenna diversity architecture).

Following channel(s) was (were) selected for the final test as listed below.

EUT CONFIGURE MODE	MODE	AVAILABLE CHANNEL	TESTED CHANNEL	MODULATION TECHNOLOGY	MODULATION TYPE	DATA RATE (Mbps)
A	802.11b	1 to 11	1, 6, 11	DSSS	DBPSK	1.0
	802.11g	1 to 11	1, 6, 11	OFDM	BPSK	6.0
	802.11n (20MHz)	1 to 11	1, 6, 11	OFDM	BPSK	MCS0
	802.11n (40MHz)	3 to 9	3, 6, 9	OFDM	BPSK	MCS0

**Test CONDITION:**

APPLICABLE TO	ENVIRONMENTAL CONDITIONS	INPUT POWER	TESTED BY
RE≥1G	25deg. C, 65%RH	120Vac, 60Hz	Kay Wu
RE<1G	25deg. C, 65%RH	120Vac, 60Hz	Kay Wu
PLC	25deg. C, 65%RH	120Vac, 60Hz	Peter Weng
APCM	25deg. C, 65%RH	120Vac, 60Hz	Howard Kao



A D T

**WLAN 5.0GHz (5745 ~ 5825MHz):**

EUT CONFIGURE MODE	APPLICABLE TO				DESCRIPTION
	RE≥1G	RE<1G	PLC	APCM	
A	√	√	√	√	Sample A from Adapter
B	-	√	√	-	Sample B from POE

Where **RE≥1G**: Radiated Emission above 1GHz      **RE<1G**: Radiated Emission below 1GHz  
**PLC**: Power Line Conducted Emission      **APCM**: Antenna Port Conducted Measurement

**NOTE:** The EUT had been pre-tested on the positioned of each 3 axis. The worst case was found when positioned on **Z-plane**.

**RADIATED EMISSION TEST (ABOVE 1GHz):**

- Pre-Scan has been conducted to determine the worst-case mode from all possible combinations between available modulations, data rates and antenna ports (if EUT with antenna diversity architecture).
- Following channel(s) was (were) selected for the final test as listed below.

EUT CONFIGURE MODE	MODE	AVAILABLE CHANNEL	TESTED CHANNEL	MODULATION TECHNOLOGY	MODULATION TYPE	DATA RATE (Mbps)
A	802.11a	149 to 165	149, 157, 165	OFDM	BPSK	6.0
	802.11n (20MHz)	149 to 165	149, 157, 165	OFDM	BPSK	MCS0
	802.11n (40MHz)	151 to 159	151, 159	OFDM	BPSK	MCS0
	802.11ac (80MHz)	155	155	OFDM	BPSK	V0

**RADIATED EMISSION TEST (BELOW 1GHz):**

- Pre-Scan has been conducted to determine the worst-case mode from all possible combinations between available modulations, data rates and antenna ports (if EUT with antenna diversity architecture).
- Following channel(s) was (were) selected for the final test as listed below.

EUT CONFIGURE MODE	MODE	AVAILABLE CHANNEL	TESTED CHANNEL	MODULATION TECHNOLOGY	MODULATION TYPE	DATA RATE (Mbps)
A, B	802.11n (20MHz)	149 to 165	165	OFDM	BPSK	MCS0

**POWER LINE CONDUCTED EMISSION TEST:**

EUT CONFIGURE MODE	MODE	AVAILABLE CHANNEL	TESTED CHANNEL	MODULATION TECHNOLOGY	MODULATION TYPE	DATA RATE (Mbps)
A, B	802.11n (20MHz)	149 to 165	165	OFDM	BPSK	MCS0



**BANDEDGE MEASUREMENT:**

Pre-Scan has been conducted to determine the worst-case mode from all possible combinations between available modulations, data rates and antenna ports (if EUT with antenna diversity architecture).

Following channel(s) was (were) selected for the final test as listed below.

EUT CONFIGURE MODE	MODE	AVAILABLE CHANNEL	TESTED CHANNEL	MODULATION TECHNOLOGY	MODULATION TYPE	DATA RATE (Mbps)
A	802.11a	149 to 165	149, 157, 165	OFDM	BPSK	6.0
	802.11n (20MHz)	149 to 165	149, 157, 165	OFDM	BPSK	MCS0
	802.11n (40MHz)	151 to 159	151, 159	OFDM	BPSK	MCS0
	802.11ac (80MHz)	155	155	OFDM	BPSK	V0

**ANTENNA PORT CONDUCTED MEASUREMENT:**

Pre-Scan has been conducted to determine the worst-case mode from all possible combinations between available modulations, data rates and antenna ports (if EUT with antenna diversity architecture).

Following channel(s) was (were) selected for the final test as listed below.

EUT CONFIGURE MODE	MODE	AVAILABLE CHANNEL	TESTED CHANNEL	MODULATION TECHNOLOGY	MODULATION TYPE	DATA RATE (Mbps)
A	802.11a	149 to 165	149, 157, 165	OFDM	BPSK	6.0
	802.11n (20MHz)	149 to 165	149, 157, 165	OFDM	BPSK	MCS0
	802.11n (40MHz)	151 to 159	151, 159	OFDM	BPSK	MCS0
	802.11ac (80MHz)	155	155	OFDM	BPSK	V0

**Test CONDITION:**

APPLICABLE TO	ENVIRONMENTAL CONDITIONS	INPUT POWER	TESTED BY
RE≥1G	25deg. C, 65%RH	120Vac, 60Hz	Kay Wu
RE<1G	25deg. C, 65%RH	120Vac, 60Hz	Kay Wu
PLC	25deg. C, 65%RH	120Vac, 60Hz	Peter Weng
APCM	25deg. C, 65%RH	120Vac, 60Hz	Howard Kao

### 3.3 DESCRIPTION OF SUPPORT UNITS

The EUT has been tested as an independent unit together with other necessary accessories or support units. The following support units or accessories were used to form a representative test configuration during the tests.

NO.	PRODUCT	BRAND	MODEL NO.	SERIAL NO.	FCC ID
1	Notebook	DELL	E6420	D3T96R1	N/A
2	POE	4ipnet	POE30G	N/A	N/A

NO.	SIGNAL CABLE DESCRIPTION OF THE ABOVE SUPPORT UNITS
1	N/A
2	N/A

**NOTE:** 1. All power cords of the above support units are non shielded (1.8m).

#### 3.3.1 CONFIGURATION OF SYSTEM UNDER TEST

For Sample A

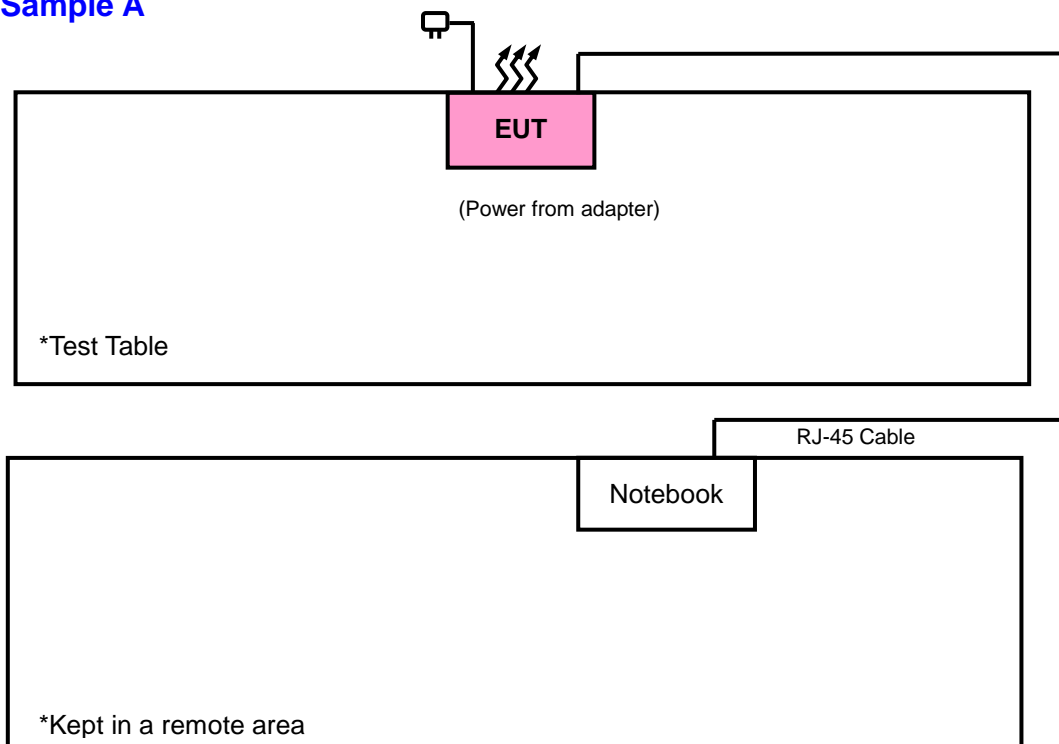



For Sample B

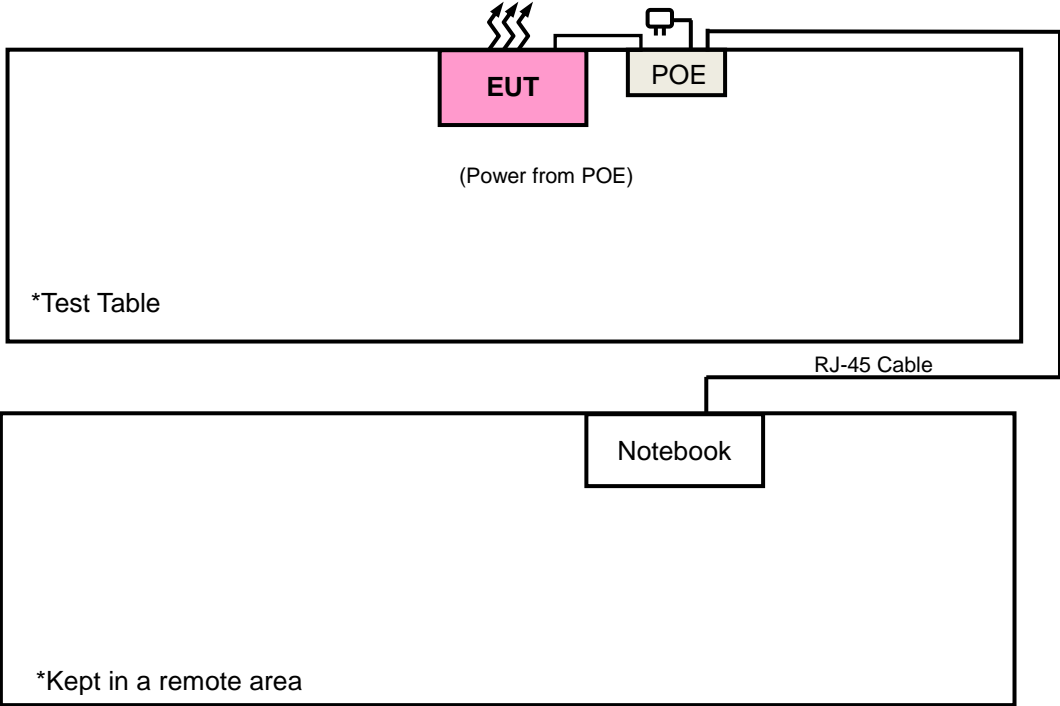



### 3.4 DUTY CYCLE TEST SIGNAL

#### WLAN 2.4GHz

#### MODE A (1TX)

**802.11b:** Duty cycle of test signal is > 98%, duty factor is not required.

If duty cycle is < 98%

**802.11g:** Duty cycle =  $2.012/2.076 = 0.969$ , Duty factor =  $10 \cdot \log(1/0.969) = 0.14$

**802.11n (20MHz):** Duty cycle =  $1.883/1.940 = 0.971$ , Duty factor =  $10 \cdot \log(1/0.971) = 0.13$

**802.11n (40MHz):** Duty cycle =  $628.076/676.153 = 0.929$ , Duty factor =  $10 \cdot \log(1/0.929) = 0.32$

#### 802.11b

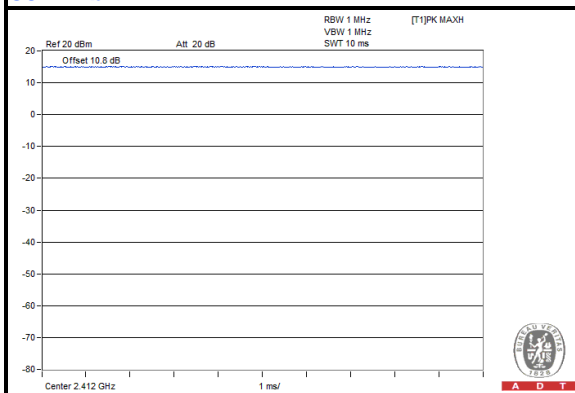

#### 802.11g

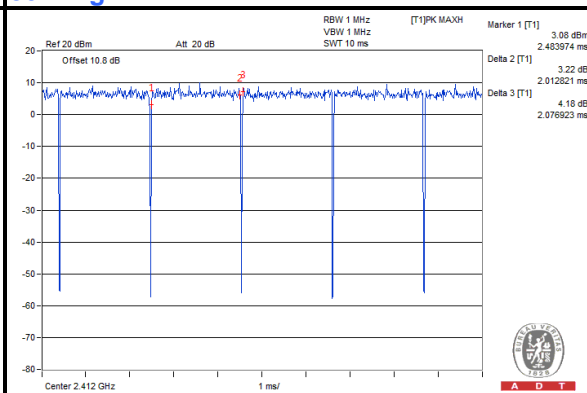

#### 802.11n (20MHz)

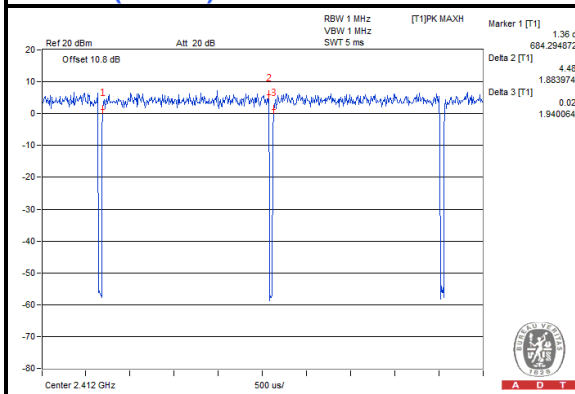

#### 802.11n (40MHz)

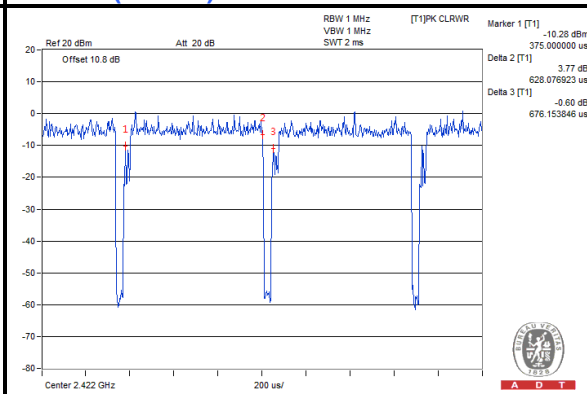



A D T

### MODE A (2TX)

**802.11n (20MHz):** Duty cycle = 1.875/1.939 = 0.967, Duty factor =  $10 \cdot \log(1/0.967) = 0.15$

**802.11n (40MHz):** Duty cycle = 625/674.743 = 0.926, Duty factor =  $10 \cdot \log(1/0.926) = 0.33$

#### 802.11n (20MHz)

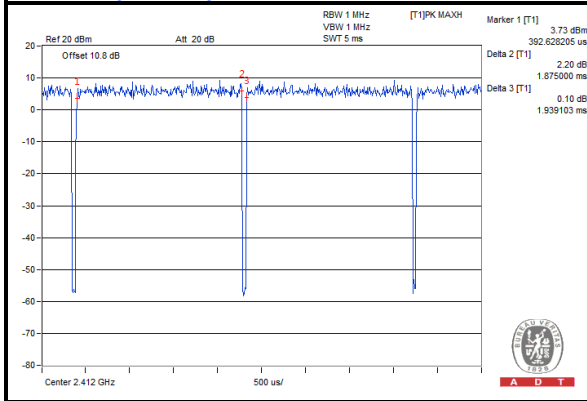

#### 802.11n (40MHz)

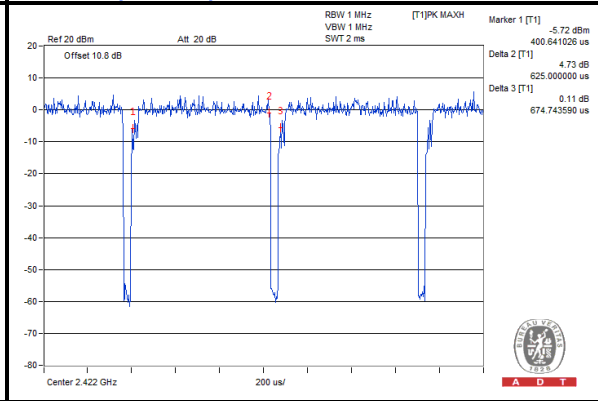

### MODE A (3TX)

**802.11n (20MHz):** Duty cycle = 1.883/1.947 = 0.967, Duty factor =  $10 \cdot \log(1/0.967) = 0.15$

**802.11n (40MHz):** Duty cycle = 630.512/675.384 = 0.934, Duty factor =  $10 \cdot \log(1/0.934) = 0.30$

#### 802.11n (20MHz)

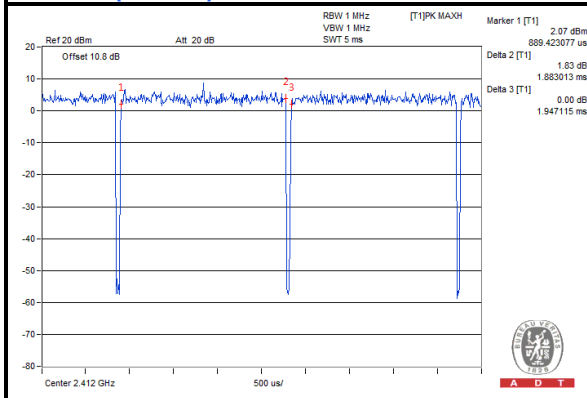

#### 802.11n (40MHz)

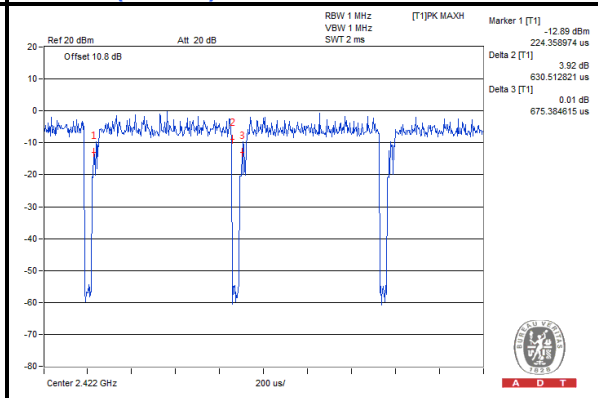



A D T

5745MHz ~ 5825MHz

MODE A (1TX)

802.11a: Duty cycle = 2.019/2.091 = 0.966, Duty factor = 10\*log(1/0.966) = 0.15

802.11n (20MHz): Duty cycle = 1.88/1.96 = 0.959, Duty factor = 10\*log(1/0.959) = 0.18

802.11n (40MHz): Duty cycle = 634.615/692.307 = 0.917, Duty factor = 10\*log(1/0.917) = 0.38

802.11ac (80MHz): Duty cycle = 316.794/371.282 = 0.853, Duty factor = 10\*log(1/0.853) = 0.69

802.11a

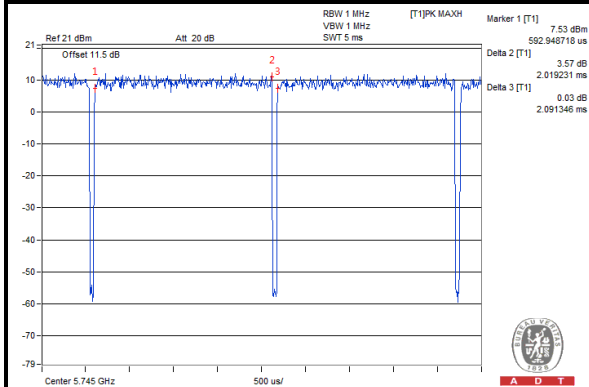

802.11n (20MHz)

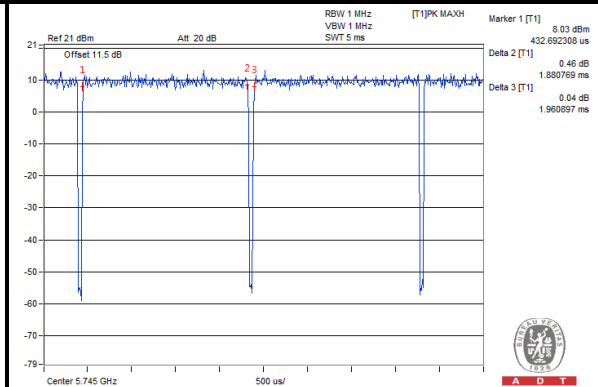

802.11n (40MHz)

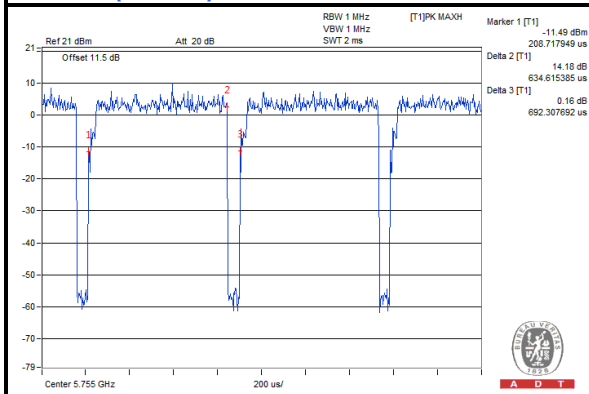

802.11ac (80MHz)

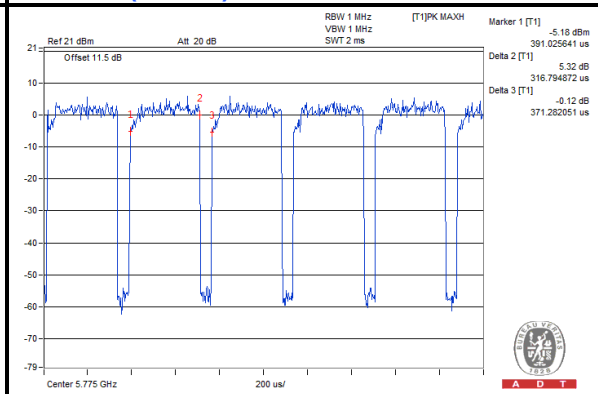



A D T

### MODE A (2TX)

**802.11n (20MHz):** Duty cycle =  $1.883/1.947 = 0.967$ , Duty factor =  $10 \cdot \log(1/0.967) = 0.15$

**802.11n (40MHz):** Duty cycle =  $621.794/685.897 = 0.907$ , Duty factor =  $10 \cdot \log(1/0.907) = 0.43$

**802.11ac (80MHz):** Duty cycle =  $320/380.897 = 0.840$ , Duty factor =  $10 \cdot \log(1/0.840) = 0.76$

#### 802.11n (20MHz)

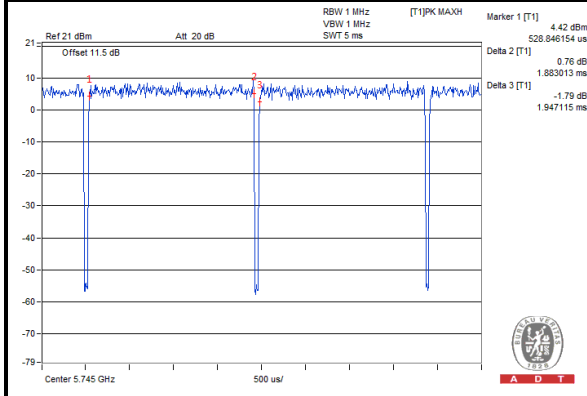

#### 802.11n (40MHz)

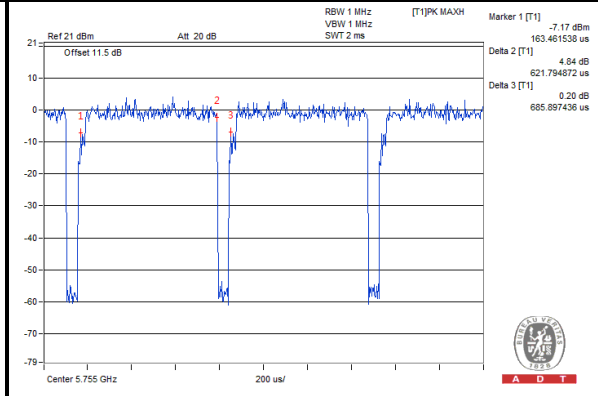

#### 802.11ac (80MHz)

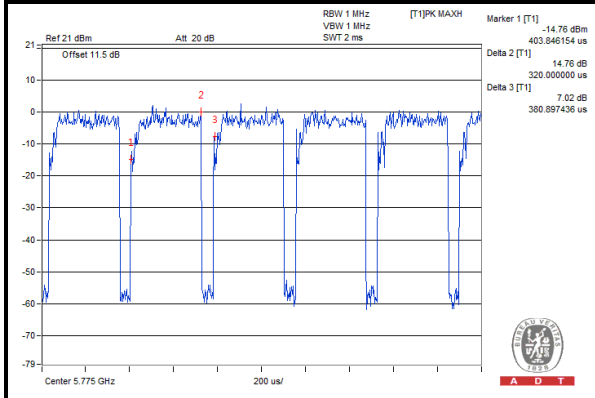



A D T

### MODE A (3TX)

**802.11n (20MHz):** Duty cycle =  $1.883/1.955 = 0.963$ , Duty factor =  $10 \cdot \log(1/0.963) = 0.16$

**802.11n (40MHz):** Duty cycle =  $623.589/687.692 = 0.907$ , Duty factor =  $10 \cdot \log(1/0.907) = 0.42$

**802.11ac (80MHz):** Duty cycle =  $319.358/373.846 = 0.854$ , Duty factor =  $10 \cdot \log(1/0.854) = 0.68$

#### 802.11n (20MHz)

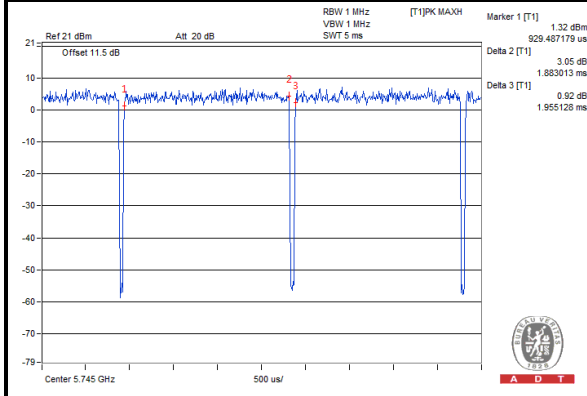

#### 802.11n (40MHz)

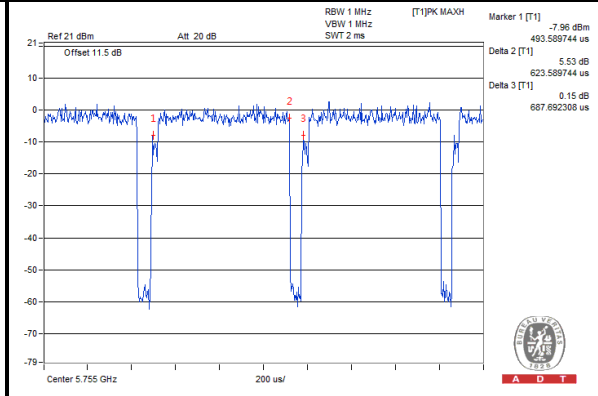

#### 802.11ac (80MHz)

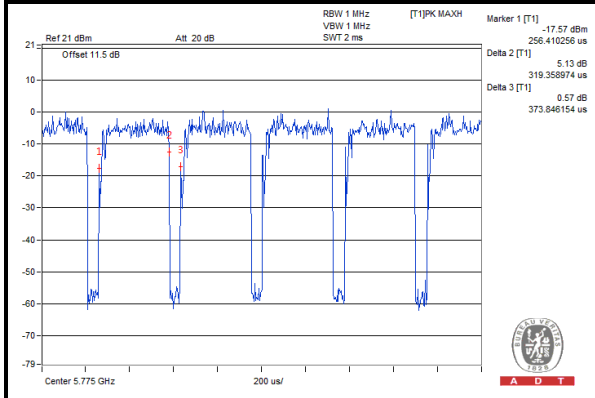



### 3.5 GENERAL DESCRIPTION OF APPLIED STANDARDS

The EUT is a RF Product. According to the specifications of the manufacturer, it must comply with the requirements of the following standards:

**FCC Part 15, Subpart C (15.247)**

**558074 D01 DTS Meas Guidance v03r01**

**662911 D01 Multiple Transmitter Output v02r01**

ANSI C63.10-2009

All test items have been performed and recorded as per the above standards.

**NOTE:** The EUT is also considered as a kind of computer peripheral, because the connection to computer is necessary for typical use. It has been verified to comply with the requirements of FCC Part 15, Subpart B, Class B (DoC). The test report has been issued separately.

## 4. TEST TYPES AND RESULTS (FOR 2.4GHz BAND)

### 4.1 RADIATED EMISSION AND BANDEDGE MEASUREMENT

#### 4.1.1 LIMITS OF RADIATED EMISSION AND BANDEDGE MEASUREMENT

Radiated emissions which fall in the restricted bands must comply with the radiated emission limits specified as below table. Other emissions shall be at least 20dB below the highest level of the desired power:

FREQUENCIES (MHz)	FIELD STRENGTH (microvolts/meter)	MEASUREMENT DISTANCE (meters)
0.009 ~ 0.490	2400/F(kHz)	300
0.490 ~ 1.705	24000/F(kHz)	30
1.705 ~ 30.0	30	30
30 ~ 88	100	3
88 ~ 216	150	3
216 ~ 960	200	3
Above 960	500	3

**NOTE:**

1. The lower limit shall apply at the transition frequencies.
2. Emission level (dBuV/m) = 20 log Emission level (uV/m).
3. For frequencies above 1000MHz, the field strength limits are based on average detector, however, the peak field strength of any emission shall not exceed the maximum permitted average limits, specified above by more than 20dB under any condition of modulation.



A D T

#### 4.1.2 TEST INSTRUMENTS

DESCRIPTION & MANUFACTURER	MODEL NO.	SERIAL NO.	DATE OF CALIBRATION	DUE DATE OF CALIBRATION
Test Receiver Agilent	N9038A	MY51210203	Jan. 17, 2014	Jan. 16, 2015
Spectrum Analyzer ROHDE & SCHWARZ	FSU43	101261	Dec. 21, 2013	Dec. 20, 2014
BILOG Antenna SCHWARZBECK	VULB9168	9168-472	Feb. 27, 2014	Feb. 26, 2015
HORN Antenna SCHWARZBECK	BBHA 9120 D	9120D-969	Feb. 19, 2014	Feb. 18, 2015
HORN Antenna SCHWARZBECK	BBHA 9170	9170-480	Dec. 18, 2013	Dec. 17, 2014
Preamplifier EMCI	EMC 012645	980115	Dec. 26, 2013	Dec. 25, 2014
Preamplifier EMCI	EMC 184045	980116	Jan. 13, 2014	Jan. 12, 2015
Preamplifier EMCI	EMC 330H	980112	Dec. 27, 2013	Dec. 26, 2014
RF signal cable HUBER+SUHNNER	SUCOFLEX 104	309219/4 2950114	Oct. 18, 2013	Oct. 17, 2014
RF signal cable HUBER+SUHNNER	SUCOFLEX 104	250130/4	Oct. 18, 2013	Oct. 17, 2014
RF signal cable Worken	RG-213	NA	Nov. 07, 2013	Nov. 06, 2014
Software BV ADT	E3 6.120103	NA	NA	NA
Antenna Tower MF	MFA-440H	NA	NA	NA
Turn Table MF	MFT-201SS	NA	NA	NA
Antenna Tower & Turn Table Controller MF	MF-7802	NA	NA	NA
Power Meter	ML2495A	1232002	Aug. 23, 2013	Aug. 22, 2014
Power Sensor	MA2411B	1207325	Aug. 23, 2013	Aug. 22, 2014

- NOTE:**
1. The calibration interval of the above test instruments is 12 months and the calibrations are traceable to NML/ROC and NIST/USA.
  2. The calibration interval of the loop antenna is 24 months and the calibrations are traceable to NML/ROC and NIST/USA.
  3. The test was performed in HwaYa Chamber 10.
  4. The horn antenna and HP preamplifier (model: 8449B) are used only for the measurement of emission frequency above 1GHz if tested.
  5. The FCC Site Registration No. is 690701.
  6. The IC Site Registration No. is IC 7450F-10.



#### 4.1.3 TEST PROCEDURES

- a. The EUT was placed on the top of a rotating table 0.8 meters above the ground at a 3 meters semi-anechoic chamber. The table was rotated 360 degrees to determine the position of the highest radiation.
- b. The EUT was set 3 meters away from the interference-receiving antenna, which was mounted on the top of a variable-height antenna tower.
- c. Height of receiving antenna is varied from one meter to four meters above the ground to determine the maximum value of the field strength. Both horizontal and vertical polarizations of the antenna are set to make the measurement.
- d. For each suspected emission, the EUT was arranged to its worst case and then the antenna was tuned to heights from 1 meter to 4 meters and the rotatable table was turned from 0 degrees to 360 degrees to find the maximum reading.
- e. The test-receiver system was set to Peak Detect Function and Specified Bandwidth with Maximum Hold Mode.
- f. If the emission level of the EUT in peak mode was lower than the limit specified, then testing could be stopped and the peak values of the EUT would be reported. Otherwise the emissions would be re-tested one by one using peak, quasi-peak or average method as specified and then reported in a data sheet.

**NOTE:**

1. The resolution bandwidth and video bandwidth of test receiver/spectrum analyzer is 120kHz for Quasi-peak detection at frequency below 1GHz.
2. The resolution bandwidth of test receiver/spectrum analyzer is 1MHz and video bandwidth is 3MHz for Peak detection at frequency above 1GHz.
3. The resolution bandwidth of test receiver/spectrum analyzer is 1MHz and the video bandwidth is 1kHz (Duty cycle < 98%) or 10Hz (Duty cycle > 98%) for Average detection (AV) at frequency above 1GHz.
4. All modes of operation were investigated and the worst-case emissions are reported.

#### 4.1.4 DEVIATION FROM TEST STANDARD

No deviation.

**4.1.5 TEST SETUP**

Frequency Range 30MHz ~ 1GHz

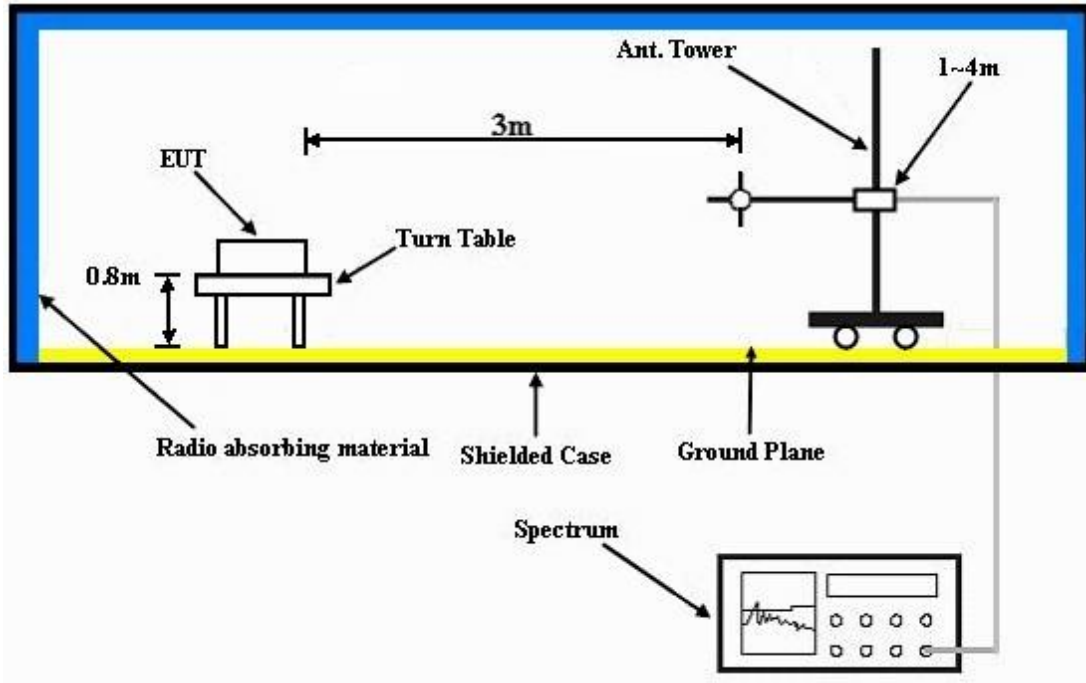

Frequency Range above 1GHz

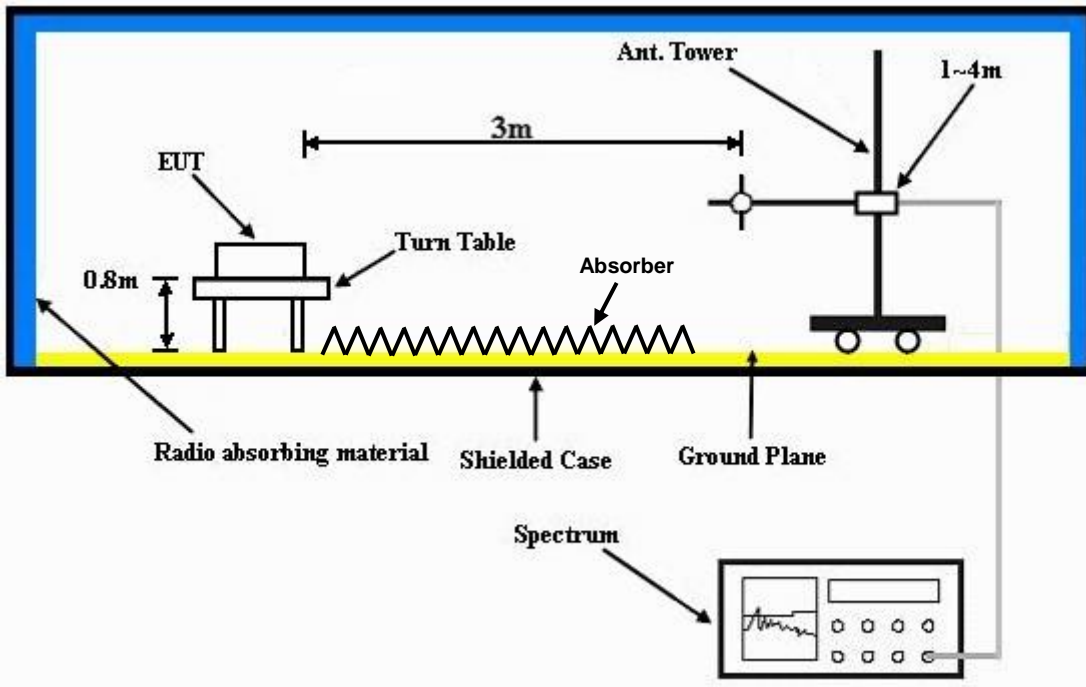

For the actual test configuration, please refer to the attached file (Test Setup Photo).



A D T

#### 4.1.6 EUT OPERATING CONDITIONS

- a. Placed the EUT on a testing table.
- b. Use the software to control the EUT under transmission condition continuously at specific channel frequency.



A D T

**4.1.7 TEST RESULTS**

**MODE A (1TX)**

**ABOVE 1GHz WORST-CASE DATA**

**802.11b**

EUT TEST CONDITION		MEASUREMENT DETAIL	
CHANNEL	Channel 1	FREQUENCY RANGE	1GHz ~ 25GHz
INPUT POWER	120Vac, 60 Hz	DETECTOR FUNCTION	Peak (PK) Average (AV)
ENVIRONMENTAL CONDITIONS	25deg. C, 65%RH	TESTED BY	Kay Wu

**ANTENNA POLARITY & TEST DISTANCE: HORIZONTAL AT 3 M**

FREQ. (MHz)	EMISSION LEVEL (dBuV/m)	READ LEVEL (dBuV)	LIMIT (dBuV/m)	MARGIN (dB)	ANTENNA FACTOR (dB/m)	CABLE LOSS (dB)	PREAMP FACTOR (dB)	ANTENNA HEIGHT (cm)	TABLE ANGLE (Degree)	REMARK
2146	59.75	58.77	90.4	-30.65	31.54	5.07	35.63	124	126	Average
2146	67.59	66.61	92.86	-25.27	31.54	5.07	35.63	124	126	Peak
2386	45.76	44.05	54	-8.24	31.8	5.4	35.49	124	126	Average
2386	56.2	54.49	74	-17.8	31.8	5.4	35.49	124	126	Peak
2412	110.4	108.63			31.81	5.43	35.47	124	126	Average
2412	112.86	111.09			31.81	5.43	35.47	124	126	Peak
2492	51.96	49.94	54	-2.04	31.9	5.53	35.41	124	126	Average
2492	63.61	61.59	74	-10.39	31.9	5.53	35.41	124	126	Peak

**ANTENNA POLARITY & TEST DISTANCE: VERTICAL AT 3 M**

FREQ. (MHz)	EMISSION LEVEL (dBuV/m)	READ LEVEL (dBuV)	LIMIT (dBuV/m)	MARGIN (dB)	ANTENNA FACTOR (dB/m)	CABLE LOSS (dB)	PREAMP FACTOR (dB)	ANTENNA HEIGHT (cm)	TABLE ANGLE (Degree)	REMARK
2148	59.7	58.66	88.93	-29.23	31.56	5.11	35.63	159	308	Average
2148	68.93	67.89	90.77	-21.84	31.56	5.11	35.63	159	308	Peak
2390	42.72	40.99	54	-11.28	31.8	5.4	35.47	159	308	Average
2390	56.49	54.76	74	-17.51	31.8	5.4	35.47	159	308	Peak
2412	108.93	107.16			31.81	5.43	35.47	159	308	Average
2412	110.77	109			31.81	5.43	35.47	159	308	Peak
2494	52.96	50.94	54	-1.04	31.9	5.53	35.41	159	308	Average
2494	61.46	59.44	74	-12.54	31.9	5.53	35.41	159	308	Peak

**REMARKS:**

- Emission Level = Read Level + Antenna Factor + Cable Loss - Preamp Factor  
Margin value = Emission level – Limit value
- 2412MHz: Fundamental frequency.
- 2146MHz & 2148MHz: Out of restricted band



A D T

EUT TEST CONDITION		MEASUREMENT DETAIL	
CHANNEL	Channel 6	FREQUENCY RANGE	1GHz ~ 25GHz
INPUT POWER	120Vac, 60 Hz	DETECTOR FUNCTION	Peak (PK) Average (AV)
ENVIRONMENTAL CONDITIONS	25deg. C, 65%RH	TESTED BY	Kay Wu

ANTENNA POLARITY & TEST DISTANCE: HORIZONTAL AT 3 M										
FREQ. (MHz)	EMISSION LEVEL (dBuV/m)	READ LEVEL (dBuV)	LIMIT (dBuV/m)	MARGIN (dB)	ANTENNA FACTOR (dB/m)	CABLE LOSS (dB)	PREAMP FACTOR (dB)	ANTENNA HEIGHT (cm)	TABLE ANGLE (Degree)	REMARK
2382	44.04	42.35	54	-9.96	31.78	5.4	35.49	130	120	Average
2382	56.12	54.43	74	-17.88	31.78	5.4	35.49	130	120	Peak
2437	110.01	108.16			31.85	5.46	35.46	130	120	Average
2437	112.91	111.06			31.85	5.46	35.46	130	120	Peak
2500	45	42.98	54	-9	31.9	5.53	35.41	130	120	Average
2500	56.33	54.31	74	-17.67	31.9	5.53	35.41	130	120	Peak

ANTENNA POLARITY & TEST DISTANCE: VERTICAL AT 3 M										
FREQ. (MHz)	EMISSION LEVEL (dBuV/m)	READ LEVEL (dBuV)	LIMIT (dBuV/m)	MARGIN (dB)	ANTENNA FACTOR (dB/m)	CABLE LOSS (dB)	PREAMP FACTOR (dB)	ANTENNA HEIGHT (cm)	TABLE ANGLE (Degree)	REMARK
2346	42.61	41.04	54	-11.39	31.74	5.33	35.5	159	308	Average
2346	54.85	53.28	74	-19.15	31.74	5.33	35.5	159	308	Peak
2437	108.28	106.43			31.85	5.46	35.46	159	308	Average
2437	110.98	109.13			31.85	5.46	35.46	159	308	Peak
2500	45.96	43.94	54	-8.04	31.9	5.53	35.41	159	308	Average
2500	58.23	56.21	74	-15.77	31.9	5.53	35.41	159	308	Peak

**REMARKS:**

- Emission Level = Read Level + Antenna Factor + Cable Loss - Preamp Factor  
Margin value = Emission level – Limit value
- 2437MHz: Fundamental frequency.



A D T

EUT TEST CONDITION		MEASUREMENT DETAIL	
CHANNEL	Channel 11	FREQUENCY RANGE	1GHz ~ 25GHz
INPUT POWER	120Vac, 60 Hz	DETECTOR FUNCTION	Peak (PK) Average (AV)
ENVIRONMENTAL CONDITIONS	25deg. C, 65%RH	TESTED BY	Kay Wu

**ANTENNA POLARITY & TEST DISTANCE: HORIZONTAL AT 3 M**

FREQ. (MHz)	EMISSION LEVEL (dBuV/m)	READ LEVEL (dBuV)	LIMIT (dBuV/m)	MARGIN (dB)	ANTENNA FACTOR (dB/m)	CABLE LOSS (dB)	PREAMP FACTOR (dB)	ANTENNA HEIGHT (cm)	TABLE ANGLE (Degree)	REMARK
2382	50.7	49.01	54	-3.3	31.78	5.4	35.49	127	122	Average
2382	60.66	58.97	74	-13.34	31.78	5.4	35.49	127	122	Peak
2462	110.93	109			31.87	5.5	35.44	127	122	Average
2462	112.93	111			31.87	5.5	35.44	127	122	Peak
2500	52.96	50.94	54	-1.04	31.9	5.53	35.41	127	122	Average
2500	61.3	59.28	74	-12.7	31.9	5.53	35.41	127	122	Peak

**ANTENNA POLARITY & TEST DISTANCE: VERTICAL AT 3 M**

FREQ. (MHz)	EMISSION LEVEL (dBuV/m)	READ LEVEL (dBuV)	LIMIT (dBuV/m)	MARGIN (dB)	ANTENNA FACTOR (dB/m)	CABLE LOSS (dB)	PREAMP FACTOR (dB)	ANTENNA HEIGHT (cm)	TABLE ANGLE (Degree)	REMARK
2384	46.75	45.06	54	-7.25	31.78	5.4	35.49	156	301	Average
2384	54.95	53.26	74	-19.05	31.78	5.4	35.49	156	301	Peak
2462	107.93	106			31.87	5.5	35.44	156	301	Average
2462	110.18	108.25			31.87	5.5	35.44	156	301	Peak
2500	52	49.98	54	-2	31.9	5.53	35.41	156	301	Average
2500	59.47	57.45	74	-14.53	31.9	5.53	35.41	156	301	Peak

**REMARKS:**

- Emission Level = Read Level + Antenna Factor + Cable Loss - Preamp Factor  
Margin value = Emission level – Limit value
- 2462MHz: Fundamental frequency.



A D T

802.11g

EUT TEST CONDITION		MEASUREMENT DETAIL	
CHANNEL	Channel 1	FREQUENCY RANGE	1GHz ~ 25GHz
INPUT POWER	120Vac, 60 Hz	DETECTOR FUNCTION	Peak (PK) Average (AV)
ENVIRONMENTAL CONDITIONS	25deg. C, 65%RH	TESTED BY	Kay Wu

**ANTENNA POLARITY & TEST DISTANCE: HORIZONTAL AT 3 M**

FREQ. (MHz)	EMISSION LEVEL (dBuV/m)	READ LEVEL (dBuV)	LIMIT (dBuV/m)	MARGIN (dB)	ANTENNA FACTOR (dB/m)	CABLE LOSS (dB)	PREAMP FACTOR (dB)	ANTENNA HEIGHT (cm)	TABLE ANGLE (Degree)	REMARK
2154	44.27	43.23	81.21	-36.94	31.56	5.11	35.63	132	129	Average
2154	59.5	58.46	89.48	-29.98	31.56	5.11	35.63	132	129	Peak
2390	52.52	50.79	54	-1.48	31.8	5.4	35.47	132	129	Average
2390	70.2	68.47	74	-3.8	31.8	5.4	35.47	132	129	Peak
2412	101.21	99.44			31.81	5.43	35.47	132	129	Average
2412	109.48	107.71			31.81	5.43	35.47	132	129	Peak
2488	42.96	40.95	54	-11.04	31.9	5.53	35.42	132	129	Average
2488	57.08	55.07	74	-16.92	31.9	5.53	35.42	132	129	Peak

**ANTENNA POLARITY & TEST DISTANCE: VERTICAL AT 3 M**

FREQ. (MHz)	EMISSION LEVEL (dBuV/m)	READ LEVEL (dBuV)	LIMIT (dBuV/m)	MARGIN (dB)	ANTENNA FACTOR (dB/m)	CABLE LOSS (dB)	PREAMP FACTOR (dB)	ANTENNA HEIGHT (cm)	TABLE ANGLE (Degree)	REMARK
2148	45.92	44.88	78.81	-32.89	31.56	5.11	35.63	159	308	Average
2148	63.28	62.24	86.99	-23.71	31.56	5.11	35.63	159	308	Peak
2390	51.23	49.5	54	-2.77	31.8	5.4	35.47	159	308	Average
2390	66.26	64.53	74	-7.74	31.8	5.4	35.47	159	308	Peak
2412	98.81	97.04			31.81	5.43	35.47	159	308	Average
2412	106.99	105.22			31.81	5.43	35.47	159	308	Peak
2500	42	39.98	54	-12	31.9	5.53	35.41	159	308	Average
2500	57.14	55.12	74	-16.86	31.9	5.53	35.41	159	308	Peak

**REMARKS:**

- Emission Level = Read Level + Antenna Factor + Cable Loss - Preamp Factor  
Margin value = Emission level – Limit value
- 2412MHz: Fundamental frequency.
- 2154MHz & 2148MHz: Out of restricted band



A D T

EUT TEST CONDITION		MEASUREMENT DETAIL	
CHANNEL	Channel 6	FREQUENCY RANGE	1GHz ~ 25GHz
INPUT POWER	120Vac, 60 Hz	DETECTOR FUNCTION	Peak (PK) Average (AV)
ENVIRONMENTAL CONDITIONS	25deg. C, 65%RH	TESTED BY	Kay Wu

ANTENNA POLARITY & TEST DISTANCE: HORIZONTAL AT 3 M										
FREQ. (MHz)	EMISSION LEVEL (dBuV/m)	READ LEVEL (dBuV)	LIMIT (dBuV/m)	MARGIN (dB)	ANTENNA FACTOR (dB/m)	CABLE LOSS (dB)	PREAMP FACTOR (dB)	ANTENNA HEIGHT (cm)	TABLE ANGLE (Degree)	REMARK
2390	42.88	41.15	54	-11.12	31.8	5.4	35.47	154	273	Average
2390	57.66	55.93	74	-16.34	31.8	5.4	35.47	154	273	Peak
2437	105.88	104.03			31.85	5.46	35.46	154	273	Average
2437	113.68	111.83			31.85	5.46	35.46	154	273	Peak
2483.5	47.28	45.32	54	-6.72	31.88	5.5	35.42	154	273	Average
2483.5	60.44	58.48	74	-13.56	31.88	5.5	35.42	154	273	Peak

ANTENNA POLARITY & TEST DISTANCE: VERTICAL AT 3 M										
FREQ. (MHz)	EMISSION LEVEL (dBuV/m)	READ LEVEL (dBuV)	LIMIT (dBuV/m)	MARGIN (dB)	ANTENNA FACTOR (dB/m)	CABLE LOSS (dB)	PREAMP FACTOR (dB)	ANTENNA HEIGHT (cm)	TABLE ANGLE (Degree)	REMARK
2390	42.88	41.15	54	-11.12	31.8	5.4	35.47	165	303	Average
2390	57.9	56.17	74	-16.1	31.8	5.4	35.47	165	303	Peak
2437	102.88	101.03			31.85	5.46	35.46	165	303	Average
2437	110.52	108.67			31.85	5.46	35.46	165	303	Peak
2500	44	41.98	54	-10	31.9	5.53	35.41	165	303	Average
2500	57.19	55.17	74	-16.81	31.9	5.53	35.41	165	303	Peak

**REMARKS:**

- Emission Level = Read Level + Antenna Factor + Cable Loss - Preamp Factor  
Margin value = Emission level – Limit value
- 2437MHz: Fundamental frequency.





A D T

EUT TEST CONDITION		MEASUREMENT DETAIL	
CHANNEL	Channel 11	FREQUENCY RANGE	1GHz ~ 25GHz
INPUT POWER	120Vac, 60 Hz	DETECTOR FUNCTION	Peak (PK) Average (AV)
ENVIRONMENTAL CONDITIONS	25deg. C, 65%RH	TESTED BY	Kay Wu

**ANTENNA POLARITY & TEST DISTANCE: HORIZONTAL AT 3 M**

FREQ. (MHz)	EMISSION LEVEL (dBuV/m)	READ LEVEL (dBuV)	LIMIT (dBuV/m)	MARGIN (dB)	ANTENNA FACTOR (dB/m)	CABLE LOSS (dB)	PREAMP FACTOR (dB)	ANTENNA HEIGHT (cm)	TABLE ANGLE (Degree)	REMARK
2384	41.74	40.05	54	-12.26	31.78	5.4	35.49	125	120	Average
2384	57.08	55.39	74	-16.92	31.78	5.4	35.49	125	120	Peak
2462	101.72	99.79			31.87	5.5	35.44	125	120	Average
2462	109.61	107.68			31.87	5.5	35.44	125	120	Peak
2483.5	53.01	51.05	54	-0.99	31.88	5.5	35.42	125	120	Average
2483.5	68.68	66.72	74	-5.32	31.88	5.5	35.42	125	120	Peak

**ANTENNA POLARITY & TEST DISTANCE: VERTICAL AT 3 M**

FREQ. (MHz)	EMISSION LEVEL (dBuV/m)	READ LEVEL (dBuV)	LIMIT (dBuV/m)	MARGIN (dB)	ANTENNA FACTOR (dB/m)	CABLE LOSS (dB)	PREAMP FACTOR (dB)	ANTENNA HEIGHT (cm)	TABLE ANGLE (Degree)	REMARK
2390	39.72	37.99	54	-14.28	31.8	5.4	35.47	163	303	Average
2390	54.9	53.17	74	-19.1	31.8	5.4	35.47	163	303	Peak
2462	99.93	98			31.87	5.5	35.44	163	303	Average
2462	107.1	105.17			31.87	5.5	35.44	163	303	Peak
2483.5	50.98	49.02	54	-3.02	31.88	5.5	35.42	163	303	Average
2483.5	65.76	63.8	74	-8.24	31.88	5.5	35.42	163	303	Peak

**REMARKS:**

- Emission Level = Read Level + Antenna Factor + Cable Loss - Preamp Factor  
Margin value = Emission level – Limit value
- 2462MHz: Fundamental frequency.



A D T

**802.11n (20MHz)**

EUT TEST CONDITION		MEASUREMENT DETAIL	
CHANNEL	Channel 1	FREQUENCY RANGE	1GHz ~ 25GHz
INPUT POWER	120Vac, 60 Hz	DETECTOR FUNCTION	Peak (PK) Average (AV)
ENVIRONMENTAL CONDITIONS	25deg. C, 65%RH	TESTED BY	Kay Wu

**ANTENNA POLARITY & TEST DISTANCE: HORIZONTAL AT 3 M**

FREQ. (MHz)	EMISSION LEVEL (dBuV/m)	READ LEVEL (dBuV)	LIMIT (dBuV/m)	MARGIN (dB)	ANTENNA FACTOR (dB/m)	CABLE LOSS (dB)	PREAMP FACTOR (dB)	ANTENNA HEIGHT (cm)	TABLE ANGLE (Degree)	REMARK
2156	45.38	44.34	79.1	-33.72	31.56	5.11	35.63	134	129	Average
2156	63.39	62.35	86.43	-23.04	31.56	5.11	35.63	134	129	Peak
2390	52.83	51.1	54	-1.17	31.8	5.4	35.47	134	129	Average
2390	68.41	66.68	74	-5.59	31.8	5.4	35.47	134	129	Peak
2412	99.1	97.33			31.81	5.43	35.47	134	129	Average
2412	106.43	104.66			31.81	5.43	35.47	134	129	Peak
2500	42	39.98	54	-12	31.9	5.53	35.41	134	129	Average
2500	56	53.98	74	-18	31.9	5.53	35.41	134	129	Peak

**ANTENNA POLARITY & TEST DISTANCE: VERTICAL AT 3 M**

FREQ. (MHz)	EMISSION LEVEL (dBuV/m)	READ LEVEL (dBuV)	LIMIT (dBuV/m)	MARGIN (dB)	ANTENNA FACTOR (dB/m)	CABLE LOSS (dB)	PREAMP FACTOR (dB)	ANTENNA HEIGHT (cm)	TABLE ANGLE (Degree)	REMARK
2148	42.96	41.92	77.14	-34.18	31.56	5.11	35.63	159	308	Average
2148	61.49	60.45	84.82	-23.33	31.56	5.11	35.63	159	308	Peak
2390	50.72	48.99	54	-3.28	31.8	5.4	35.47	159	308	Average
2390	67.65	65.92	74	-6.35	31.8	5.4	35.47	159	308	Peak
2412	97.14	95.37			31.81	5.43	35.47	159	308	Average
2412	104.82	103.05			31.81	5.43	35.47	159	308	Peak
2500	39.96	37.94	54	-14.04	31.9	5.53	35.41	159	308	Average
2500	57.17	55.15	74	-16.83	31.9	5.53	35.41	159	308	Peak

**REMARKS:**

- Emission Level = Read Level + Antenna Factor + Cable Loss - Preamp Factor  
Margin value = Emission level – Limit value
- 2412MHz: Fundamental frequency.
- 2156MHz & 2148MHz: Out of restricted band



A D T

EUT TEST CONDITION		MEASUREMENT DETAIL	
CHANNEL	Channel 6	FREQUENCY RANGE	1GHz ~ 25GHz
INPUT POWER	120Vac, 60 Hz	DETECTOR FUNCTION	Peak (PK) Average (AV)
ENVIRONMENTAL CONDITIONS	25deg. C, 65%RH	TESTED BY	Kay Wu

ANTENNA POLARITY & TEST DISTANCE: HORIZONTAL AT 3 M										
FREQ. (MHz)	EMISSION LEVEL (dBuV/m)	READ LEVEL (dBuV)	LIMIT (dBuV/m)	MARGIN (dB)	ANTENNA FACTOR (dB/m)	CABLE LOSS (dB)	PREAMP FACTOR (dB)	ANTENNA HEIGHT (cm)	TABLE ANGLE (Degree)	REMARK
2390	45.06	43.33	54	-8.94	31.8	5.4	35.47	132	129	Average
2390	59.42	57.69	74	-14.58	31.8	5.4	35.47	132	129	Peak
2437	104.88	103.03			31.85	5.46	35.46	132	129	Average
2437	111.53	109.68			31.85	5.46	35.46	132	129	Peak
2490	45	42.99	54	-9	31.9	5.53	35.42	132	129	Average
2490	58.05	56.04	74	-15.95	31.9	5.53	35.42	132	129	Peak

ANTENNA POLARITY & TEST DISTANCE: VERTICAL AT 3 M										
FREQ. (MHz)	EMISSION LEVEL (dBuV/m)	READ LEVEL (dBuV)	LIMIT (dBuV/m)	MARGIN (dB)	ANTENNA FACTOR (dB/m)	CABLE LOSS (dB)	PREAMP FACTOR (dB)	ANTENNA HEIGHT (cm)	TABLE ANGLE (Degree)	REMARK
2390	44.74	43.01	54	-9.26	31.8	5.4	35.47	159	308	Average
2390	58.9	57.17	74	-15.1	31.8	5.4	35.47	159	308	Peak
2437	101.88	100.03			31.85	5.46	35.46	159	308	Average
2437	109.87	108.02			31.85	5.46	35.46	159	308	Peak
2484	45.07	43.11	54	-8.93	31.88	5.5	35.42	159	308	Average
2484	59.31	57.35	74	-14.69	31.88	5.5	35.42	159	308	Peak

**REMARKS:**

- Emission Level = Read Level + Antenna Factor + Cable Loss - Preamp Factor  
Margin value = Emission level – Limit value
- 2437MHz: Fundamental frequency.



A D T

EUT TEST CONDITION		MEASUREMENT DETAIL	
CHANNEL	Channel 11	FREQUENCY RANGE	1GHz ~ 25GHz
INPUT POWER	120Vac, 60 Hz	DETECTOR FUNCTION	Peak (PK) Average (AV)
ENVIRONMENTAL CONDITIONS	25deg. C, 65%RH	TESTED BY	Kay Wu

ANTENNA POLARITY & TEST DISTANCE: HORIZONTAL AT 3 M										
FREQ. (MHz)	EMISSION LEVEL (dBuV/m)	READ LEVEL (dBuV)	LIMIT (dBuV/m)	MARGIN (dB)	ANTENNA FACTOR (dB/m)	CABLE LOSS (dB)	PREAMP FACTOR (dB)	ANTENNA HEIGHT (cm)	TABLE ANGLE (Degree)	REMARK
2390	44.72	42.99	54	-9.28	31.8	5.4	35.47	125	122	Average
2390	56.94	55.21	74	-17.06	31.8	5.4	35.47	125	122	Peak
2462	100.6	98.67			31.87	5.5	35.44	125	122	Average
2462	108.45	106.52			31.87	5.5	35.44	125	122	Peak
2483.5	52.75	50.79	54	-1.25	31.88	5.5	35.42	125	122	Average
2483.5	69.05	67.09	74	-4.95	31.88	5.5	35.42	125	122	Peak

ANTENNA POLARITY & TEST DISTANCE: VERTICAL AT 3 M										
FREQ. (MHz)	EMISSION LEVEL (dBuV/m)	READ LEVEL (dBuV)	LIMIT (dBuV/m)	MARGIN (dB)	ANTENNA FACTOR (dB/m)	CABLE LOSS (dB)	PREAMP FACTOR (dB)	ANTENNA HEIGHT (cm)	TABLE ANGLE (Degree)	REMARK
2382	42.7	41.01	54	-11.3	31.78	5.4	35.49	154	308	Average
2382	55.07	53.38	74	-18.93	31.78	5.4	35.49	154	308	Peak
2462	97.93	96			31.87	5.5	35.44	154	308	Average
2462	105.17	103.24			31.87	5.5	35.44	154	308	Peak
2483.5	47.28	45.32	54	-6.72	31.88	5.5	35.42	154	308	Average
2483.5	62.96	61	74	-11.04	31.88	5.5	35.42	154	308	Peak

**REMARKS:**

- Emission Level = Read Level + Antenna Factor + Cable Loss - Preamp Factor  
Margin value = Emission level – Limit value
- 2462MHz: Fundamental frequency.



A D T

802.11n (40MHz)

EUT TEST CONDITION		MEASUREMENT DETAIL	
CHANNEL	Channel 3	FREQUENCY RANGE	1GHz ~ 25GHz
INPUT POWER	120Vac, 60 Hz	DETECTOR FUNCTION	Peak (PK) Average (AV)
ENVIRONMENTAL CONDITIONS	25deg. C, 65%RH	TESTED BY	Kay Wu

ANTENNA POLARITY & TEST DISTANCE: HORIZONTAL AT 3 M										
FREQ. (MHz)	EMISSION LEVEL (dBuV/m)	READ LEVEL (dBuV)	LIMIT (dBuV/m)	MARGIN (dB)	ANTENNA FACTOR (dB/m)	CABLE LOSS (dB)	PREAMP FACTOR (dB)	ANTENNA HEIGHT (cm)	TABLE ANGLE (Degree)	REMARK
2390	51.59	49.86	54	-2.41	31.8	5.4	35.47	186	314	Average
2390	67.38	65.65	74	-6.62	31.8	5.4	35.47	186	314	Peak
2422	94.03	92.23			31.83	5.43	35.46	186	314	Average
2422	102.52	100.72			31.83	5.43	35.46	186	314	Peak
2500	40.96	38.94	54	-13.04	31.9	5.53	35.41	186	314	Average
2500	55.87	53.85	74	-18.13	31.9	5.53	35.41	186	314	Peak
ANTENNA POLARITY & TEST DISTANCE: VERTICAL AT 3 M										
FREQ. (MHz)	EMISSION LEVEL (dBuV/m)	READ LEVEL (dBuV)	LIMIT (dBuV/m)	MARGIN (dB)	ANTENNA FACTOR (dB/m)	CABLE LOSS (dB)	PREAMP FACTOR (dB)	ANTENNA HEIGHT (cm)	TABLE ANGLE (Degree)	REMARK
2390	50.76	49.03	54	-3.24	31.8	5.4	35.47	137	76	Average
2390	65.51	63.78	74	-8.49	31.8	5.4	35.47	137	76	Peak
2422	93.83	92.03			31.83	5.43	35.46	137	76	Average
2422	101.32	99.52			31.83	5.43	35.46	137	76	Peak
2500	42	39.98	54	-12	31.9	5.53	35.41	137	76	Average
2500	57.02	55	74	-16.98	31.9	5.53	35.41	137	76	Peak

REMARKS:

- Emission Level = Read Level + Antenna Factor + Cable Loss - Preamp Factor  
Margin value = Emission level – Limit value
- 2422MHz: Fundamental frequency.



A D T

EUT TEST CONDITION		MEASUREMENT DETAIL	
CHANNEL	Channel 6	FREQUENCY RANGE	1GHz ~ 25GHz
INPUT POWER	120Vac, 60 Hz	DETECTOR FUNCTION	Peak (PK) Average (AV)
ENVIRONMENTAL CONDITIONS	25deg. C, 65%RH	TESTED BY	Kay Wu

**ANTENNA POLARITY & TEST DISTANCE: HORIZONTAL AT 3 M**

FREQ. (MHz)	EMISSION LEVEL (dBuV/m)	READ LEVEL (dBuV)	LIMIT (dBuV/m)	MARGIN (dB)	ANTENNA FACTOR (dB/m)	CABLE LOSS (dB)	PREAMP FACTOR (dB)	ANTENNA HEIGHT (cm)	TABLE ANGLE (Degree)	REMARK
2390	46.16	44.43	54	-7.84	31.8	5.4	35.47	183	297	Average
2390	60.67	58.94	74	-13.33	31.8	5.4	35.47	183	297	Peak
2437	97.58	95.73			31.85	5.46	35.46	183	297	Average
2437	105.93	104.08			31.85	5.46	35.46	183	297	Peak
2483.5	52.35	50.39	54	-1.65	31.88	5.5	35.42	183	297	Average
2483.5	65.95	63.99	74	-8.05	31.88	5.5	35.42	183	297	Peak

**ANTENNA POLARITY & TEST DISTANCE: VERTICAL AT 3 M**

FREQ. (MHz)	EMISSION LEVEL (dBuV/m)	READ LEVEL (dBuV)	LIMIT (dBuV/m)	MARGIN (dB)	ANTENNA FACTOR (dB/m)	CABLE LOSS (dB)	PREAMP FACTOR (dB)	ANTENNA HEIGHT (cm)	TABLE ANGLE (Degree)	REMARK
2388	44.55	42.84	54	-9.45	31.8	5.4	35.49	137	76	Average
2388	60.35	58.64	74	-13.65	31.8	5.4	35.49	137	76	Peak
2437	96.17	94.32			31.85	5.46	35.46	137	76	Average
2437	104.16	102.31			31.85	5.46	35.46	137	76	Peak
2483.5	51.91	49.95	54	-2.09	31.88	5.5	35.42	137	76	Average
2483.5	62.42	60.46	74	-11.58	31.88	5.5	35.42	137	76	Peak

**REMARKS:**

- Emission Level = Read Level + Antenna Factor + Cable Loss - Preamp Factor  
Margin value = Emission level – Limit value
- 2437MHz: Fundamental frequency.



A D T

EUT TEST CONDITION		MEASUREMENT DETAIL	
CHANNEL	Channel 9	FREQUENCY RANGE	1GHz ~ 25GHz
INPUT POWER	120Vac, 60 Hz	DETECTOR FUNCTION	Peak (PK) Average (AV)
ENVIRONMENTAL CONDITIONS	25deg. C, 65%RH	TESTED BY	Kay Wu

**ANTENNA POLARITY & TEST DISTANCE: HORIZONTAL AT 3 M**

FREQ. (MHz)	EMISSION LEVEL (dBuV/m)	READ LEVEL (dBuV)	LIMIT (dBuV/m)	MARGIN (dB)	ANTENNA FACTOR (dB/m)	CABLE LOSS (dB)	PREAMP FACTOR (dB)	ANTENNA HEIGHT (cm)	TABLE ANGLE (Degree)	REMARK
2380	42.01	40.35	54	-11.99	31.78	5.37	35.49	185	298	Average
2380	55.98	54.32	74	-18.02	31.78	5.37	35.49	185	298	Peak
2452	94.4	92.53			31.85	5.46	35.44	185	298	Average
2452	102.83	100.96			31.85	5.46	35.44	185	298	Peak
2483.5	52.59	50.63	54	-1.41	31.88	5.5	35.42	185	298	Average
2483.5	66.65	64.69	74	-7.35	31.88	5.5	35.42	185	298	Peak

**ANTENNA POLARITY & TEST DISTANCE: VERTICAL AT 3 M**

FREQ. (MHz)	EMISSION LEVEL (dBuV/m)	READ LEVEL (dBuV)	LIMIT (dBuV/m)	MARGIN (dB)	ANTENNA FACTOR (dB/m)	CABLE LOSS (dB)	PREAMP FACTOR (dB)	ANTENNA HEIGHT (cm)	TABLE ANGLE (Degree)	REMARK
2382	42.7	41.01	54	-11.3	31.78	5.4	35.49	137	76	Average
2382	55.39	53.7	74	-18.61	31.78	5.4	35.49	137	76	Peak
2452	93.61	91.74			31.85	5.46	35.44	137	76	Average
2452	101.44	99.57			31.85	5.46	35.44	137	76	Peak
2483.5	50.91	48.95	54	-3.09	31.88	5.5	35.42	137	76	Average
2483.5	65.11	63.15	74	-8.89	31.88	5.5	35.42	137	76	Peak

**REMARKS:**

- Emission Level = Read Level + Antenna Factor + Cable Loss - Preamp Factor  
Margin value = Emission level – Limit value
- 2452MHz: Fundamental frequency.



A D T

**MODE A (2TX)**

**802.11n (20MHz)**

EUT TEST CONDITION		MEASUREMENT DETAIL	
CHANNEL	Channel 1	FREQUENCY RANGE	1GHz ~ 25GHz
INPUT POWER	120Vac, 60 Hz	DETECTOR FUNCTION	Peak (PK) Average (AV)
ENVIRONMENTAL CONDITIONS	25deg. C, 65%RH	TESTED BY	Kay Wu

**ANTENNA POLARITY & TEST DISTANCE: HORIZONTAL AT 3 M**

FREQ. (MHz)	EMISSION LEVEL (dBuV/m)	READ LEVEL (dBuV)	LIMIT (dBuV/m)	MARGIN (dB)	ANTENNA FACTOR (dB/m)	CABLE LOSS (dB)	PREAMP FACTOR (dB)	ANTENNA HEIGHT (cm)	TABLE ANGLE (Degree)	REMARK
2390	46.06	44.33	54	-7.94	31.8	5.4	35.47	115	156	Average
2390	61.55	59.82	74	-12.45	31.8	5.4	35.47	115	156	Peak
2412	105.1	103.33			31.81	5.43	35.47	115	156	Average
2412	112.76	110.99			31.81	5.43	35.47	115	156	Peak
2500	43.06	41.04	54	-10.94	31.9	5.53	35.41	115	156	Average
2500	56.92	54.9	74	-17.08	31.9	5.53	35.41	115	156	Peak

**ANTENNA POLARITY & TEST DISTANCE: VERTICAL AT 3 M**

FREQ. (MHz)	EMISSION LEVEL (dBuV/m)	READ LEVEL (dBuV)	LIMIT (dBuV/m)	MARGIN (dB)	ANTENNA FACTOR (dB/m)	CABLE LOSS (dB)	PREAMP FACTOR (dB)	ANTENNA HEIGHT (cm)	TABLE ANGLE (Degree)	REMARK
2390	48.76	47.03	54	-5.24	31.8	5.4	35.47	107	37	Average
2390	66.35	64.62	74	-7.65	31.8	5.4	35.47	107	37	Peak
2412	105.6	103.83			31.81	5.43	35.47	106	176	Average
2412	113.35	111.58			31.81	5.43	35.47	106	176	Peak
2486	45.27	43.28	54	-8.73	31.88	5.53	35.42	106	176	Average
2486	60.06	58.07	74	-13.94	31.88	5.53	35.42	106	176	Peak

**REMARKS:**

1. Emission Level = Read Level + Antenna Factor + Cable Loss - Preamp Factor

Margin value = Emission level – Limit value

2. 2412MHz: Fundamental frequency.





A D T

EUT TEST CONDITION		MEASUREMENT DETAIL	
CHANNEL	Channel 6	FREQUENCY RANGE	1GHz ~ 25GHz
INPUT POWER	120Vac, 60 Hz	DETECTOR FUNCTION	Peak (PK) Average (AV)
ENVIRONMENTAL CONDITIONS	25deg. C, 65%RH	TESTED BY	Kay Wu

**ANTENNA POLARITY & TEST DISTANCE: HORIZONTAL AT 3 M**

FREQ. (MHz)	EMISSION LEVEL (dBuV/m)	READ LEVEL (dBuV)	LIMIT (dBuV/m)	MARGIN (dB)	ANTENNA FACTOR (dB/m)	CABLE LOSS (dB)	PREAMP FACTOR (dB)	ANTENNA HEIGHT (cm)	TABLE ANGLE (Degree)	REMARK
2388	43.06	41.35	54	-10.94	31.8	5.4	35.49	112	154	Average
2388	55.86	54.15	74	-18.14	31.8	5.4	35.49	112	154	Peak
2437	105.9	104.05			31.85	5.46	35.46	112	154	Average
2437	112.79	110.94			31.85	5.46	35.46	112	154	Peak
2500	44.29	42.27	54	-9.71	31.9	5.53	35.41	112	154	Average
2500	58.7	56.68	74	-15.3	31.9	5.53	35.41	112	154	Peak

**ANTENNA POLARITY & TEST DISTANCE: VERTICAL AT 3 M**

FREQ. (MHz)	EMISSION LEVEL (dBuV/m)	READ LEVEL (dBuV)	LIMIT (dBuV/m)	MARGIN (dB)	ANTENNA FACTOR (dB/m)	CABLE LOSS (dB)	PREAMP FACTOR (dB)	ANTENNA HEIGHT (cm)	TABLE ANGLE (Degree)	REMARK
2390	43.09	41.36	54	-10.91	31.8	5.4	35.47	104	186	Average
2390	57.76	56.03	74	-16.24	31.8	5.4	35.47	104	186	Peak
2437	105.67	103.82			31.85	5.46	35.46	104	186	Average
2437	113.41	111.56			31.85	5.46	35.46	104	186	Peak
2500	44	41.98	54	-10	31.9	5.53	35.41	104	186	Average
2500	57.9	55.88	74	-16.1	31.9	5.53	35.41	104	186	Peak

**REMARKS:**

- Emission Level = Read Level + Antenna Factor + Cable Loss - Preamp Factor  
Margin value = Emission level – Limit value
- 2437MHz: Fundamental frequency.



A D T

EUT TEST CONDITION		MEASUREMENT DETAIL	
CHANNEL	Channel 11	FREQUENCY RANGE	1GHz ~ 25GHz
INPUT POWER	120Vac, 60 Hz	DETECTOR FUNCTION	Peak (PK) Average (AV)
ENVIRONMENTAL CONDITIONS	25deg. C, 65%RH	TESTED BY	Kay Wu

**ANTENNA POLARITY & TEST DISTANCE: HORIZONTAL AT 3 M**

FREQ. (MHz)	EMISSION LEVEL (dBuV/m)	READ LEVEL (dBuV)	LIMIT (dBuV/m)	MARGIN (dB)	ANTENNA FACTOR (dB/m)	CABLE LOSS (dB)	PREAMP FACTOR (dB)	ANTENNA HEIGHT (cm)	TABLE ANGLE (Degree)	REMARK
2384	42.73	41.04	54	-11.27	31.78	5.4	35.49	111	191	Average
2384	55.57	53.88	74	-18.43	31.78	5.4	35.49	111	191	Peak
2462	105.93	104			31.87	5.5	35.44	111	191	Average
2462	112.02	110.09			31.87	5.5	35.44	111	191	Peak
2483.5	52.07	50.11	54	-1.93	31.88	5.5	35.42	112	178	Average
2483.5	68.2	66.24	74	-5.8	31.88	5.5	35.42	112	178	Peak

**ANTENNA POLARITY & TEST DISTANCE: VERTICAL AT 3 M**

FREQ. (MHz)	EMISSION LEVEL (dBuV/m)	READ LEVEL (dBuV)	LIMIT (dBuV/m)	MARGIN (dB)	ANTENNA FACTOR (dB/m)	CABLE LOSS (dB)	PREAMP FACTOR (dB)	ANTENNA HEIGHT (cm)	TABLE ANGLE (Degree)	REMARK
2390	46.06	44.33	54	-7.94	31.8	5.4	35.47	105	182	Average
2390	58.47	56.74	74	-15.53	31.8	5.4	35.47	105	182	Peak
2462	105.48	103.55			31.87	5.5	35.44	105	182	Average
2462	113.89	111.96			31.87	5.5	35.44	105	182	Peak
2483.5	52.07	50.11	54	-1.93	31.88	5.5	35.42	125	170	Average
2483.5	70.53	68.57	74	-3.47	31.88	5.5	35.42	125	170	Peak

**REMARKS:**

- Emission Level = Read Level + Antenna Factor + Cable Loss - Preamp Factor  
Margin value = Emission level – Limit value
- 2462MHz: Fundamental frequency.



A D T

**802.11n (40MHz)**

EUT TEST CONDITION		MEASUREMENT DETAIL	
CHANNEL	Channel 3	FREQUENCY RANGE	1GHz ~ 25GHz
INPUT POWER	120Vac, 60 Hz	DETECTOR FUNCTION	Peak (PK) Average (AV)
ENVIRONMENTAL CONDITIONS	25deg. C, 65%RH	TESTED BY	Kay Wu

ANTENNA POLARITY & TEST DISTANCE: HORIZONTAL AT 3 M										
FREQ. (MHz)	EMISSION LEVEL (dBuV/m)	READ LEVEL (dBuV)	LIMIT (dBuV/m)	MARGIN (dB)	ANTENNA FACTOR (dB/m)	CABLE LOSS (dB)	PREAMP FACTOR (dB)	ANTENNA HEIGHT (cm)	TABLE ANGLE (Degree)	REMARK
2388	50.32	48.61	54	-3.68	31.8	5.4	35.49	114	168	Average
2388	64.24	62.53	74	-9.76	31.8	5.4	35.49	114	168	Peak
2422	100.12	98.32			31.83	5.43	35.46	114	168	Average
2422	107.02	105.22			31.83	5.43	35.46	114	168	Peak
2500	46.29	44.27	54	-7.71	31.9	5.53	35.41	114	168	Average
2500	58.8	56.78	74	-15.2	31.9	5.53	35.41	114	168	Peak
ANTENNA POLARITY & TEST DISTANCE: VERTICAL AT 3 M										
FREQ. (MHz)	EMISSION LEVEL (dBuV/m)	READ LEVEL (dBuV)	LIMIT (dBuV/m)	MARGIN (dB)	ANTENNA FACTOR (dB/m)	CABLE LOSS (dB)	PREAMP FACTOR (dB)	ANTENNA HEIGHT (cm)	TABLE ANGLE (Degree)	REMARK
2390	52.18	50.45	54	-1.82	31.8	5.4	35.47	108	213	Average
2390	67.35	65.62	74	-6.65	31.8	5.4	35.47	108	213	Peak
2422	100.83	99.03			31.83	5.43	35.46	107	184	Average
2422	108.36	106.56			31.83	5.43	35.46	107	184	Peak
2500	43	40.98	54	-11	31.9	5.53	35.41	107	184	Average
2500	58.92	56.9	74	-15.08	31.9	5.53	35.41	107	184	Peak

**REMARKS:**

- Emission Level = Read Level + Antenna Factor + Cable Loss - Preamp Factor  
Margin value = Emission level – Limit value
- 2422MHz: Fundamental frequency.



A D T

EUT TEST CONDITION		MEASUREMENT DETAIL	
CHANNEL	Channel 6	FREQUENCY RANGE	1GHz ~ 25GHz
INPUT POWER	120Vac, 60 Hz	DETECTOR FUNCTION	Peak (PK) Average (AV)
ENVIRONMENTAL CONDITIONS	25deg. C, 65%RH	TESTED BY	Kay Wu

**ANTENNA POLARITY & TEST DISTANCE: HORIZONTAL AT 3 M**

FREQ. (MHz)	EMISSION LEVEL (dBuV/m)	READ LEVEL (dBuV)	LIMIT (dBuV/m)	MARGIN (dB)	ANTENNA FACTOR (dB/m)	CABLE LOSS (dB)	PREAMP FACTOR (dB)	ANTENNA HEIGHT (cm)	TABLE ANGLE (Degree)	REMARK
2390	46.06	44.33	54	-7.94	31.8	5.4	35.47	111	155	Average
2390	57.1	55.37	74	-16.9	31.8	5.4	35.47	111	155	Peak
2437	100.88	99.03			31.85	5.46	35.46	111	155	Average
2437	109.11	107.26			31.85	5.46	35.46	111	155	Peak
2486	51.27	49.28	54	-2.73	31.88	5.53	35.42	111	155	Average
2486	63.47	61.48	74	-10.53	31.88	5.53	35.42	111	155	Peak

**ANTENNA POLARITY & TEST DISTANCE: VERTICAL AT 3 M**

FREQ. (MHz)	EMISSION LEVEL (dBuV/m)	READ LEVEL (dBuV)	LIMIT (dBuV/m)	MARGIN (dB)	ANTENNA FACTOR (dB/m)	CABLE LOSS (dB)	PREAMP FACTOR (dB)	ANTENNA HEIGHT (cm)	TABLE ANGLE (Degree)	REMARK
2390	45.77	44.04	54	-8.23	31.8	5.4	35.47	104	184	Average
2390	61.75	60.02	74	-12.25	31.8	5.4	35.47	104	184	Peak
2437	101.47	99.62			31.85	5.46	35.46	104	184	Average
2437	110.08	108.23			31.85	5.46	35.46	104	184	Peak
2483.5	53.06	51.1	54	-0.94	31.88	5.5	35.42	110	178	Average
2483.5	64.11	62.15	74	-9.89	31.88	5.5	35.42	110	178	Peak

**REMARKS:**

- Emission Level = Read Level + Antenna Factor + Cable Loss - Preamp Factor  
Margin value = Emission level – Limit value
- 2437MHz: Fundamental frequency.



A D T

EUT TEST CONDITION		MEASUREMENT DETAIL	
CHANNEL	Channel 9	FREQUENCY RANGE	1GHz ~ 25GHz
INPUT POWER	120Vac, 60 Hz	DETECTOR FUNCTION	Peak (PK) Average (AV)
ENVIRONMENTAL CONDITIONS	25deg. C, 65%RH	TESTED BY	Kay Wu

**ANTENNA POLARITY & TEST DISTANCE: HORIZONTAL AT 3 M**

FREQ. (MHz)	EMISSION LEVEL (dBuV/m)	READ LEVEL (dBuV)	LIMIT (dBuV/m)	MARGIN (dB)	ANTENNA FACTOR (dB/m)	CABLE LOSS (dB)	PREAMP FACTOR (dB)	ANTENNA HEIGHT (cm)	TABLE ANGLE (Degree)	REMARK
2390	41.72	39.99	54	-12.28	31.8	5.4	35.47	111	155	Average
2390	55.6	53.87	74	-18.4	31.8	5.4	35.47	111	155	Peak
2452	97.84	95.97			31.85	5.46	35.44	111	155	Average
2452	106.29	104.42			31.85	5.46	35.44	111	155	Peak
2483.5	50.95	48.99	54	-3.05	31.88	5.5	35.42	111	155	Average
2483.5	66.55	64.59	74	-7.45	31.88	5.5	35.42	111	155	Peak

**ANTENNA POLARITY & TEST DISTANCE: VERTICAL AT 3 M**

FREQ. (MHz)	EMISSION LEVEL (dBuV/m)	READ LEVEL (dBuV)	LIMIT (dBuV/m)	MARGIN (dB)	ANTENNA FACTOR (dB/m)	CABLE LOSS (dB)	PREAMP FACTOR (dB)	ANTENNA HEIGHT (cm)	TABLE ANGLE (Degree)	REMARK
2384	43.04	41.35	54	-10.96	31.78	5.4	35.49	104	184	Average
2384	59.7	58.01	74	-14.3	31.78	5.4	35.49	104	184	Peak
2452	99.88	98.01			31.85	5.46	35.44	104	184	Average
2452	107.54	105.67			31.85	5.46	35.44	104	184	Peak
2483.5	52.74	50.78	54	-1.26	31.88	5.5	35.42	106	183	Average
2483.5	69.39	67.43	74	-4.61	31.88	5.5	35.42	106	183	Peak

**REMARKS:**

- Emission Level = Read Level + Antenna Factor + Cable Loss - Preamp Factor  
Margin value = Emission level – Limit value
- 2452MHz: Fundamental frequency.



A D T

**MODE A (co-location)**

**802.11n (40MHz) + 802.11ac (80MHz)**

EUT TEST CONDITION		MEASUREMENT DETAIL	
CHANNEL	Ch. 6 + Ch. 42	FREQUENCY RANGE	1GHz ~ 40GHz
INPUT POWER	120Vac, 60 Hz	DETECTOR FUNCTION	Peak (PK) Average (AV)
ENVIRONMENTAL CONDITIONS	25deg. C, 65%RH	TESTED BY	Kay Wu

**ANTENNA POLARITY & TEST DISTANCE: HORIZONTAL AT 3 M**

FREQ. (MHz)	EMISSION LEVEL (dBuV/m)	READ LEVEL (dBuV)	LIMIT (dBuV/m)	MARGIN (dB)	ANTENNA FACTOR (dB/m)	CABLE LOSS (dB)	PREAMP FACTOR (dB)	ANTENNA HEIGHT (cm)	TABLE ANGLE (Degree)	REMARK
2388	45.85	52.9	54	-8.15	26.91	3.54	37.5	100	198	Average
2388	65.2	72.25	74	-8.8	26.91	3.54	37.5	100	198	Peak
2437	99.72	106.56			27.06	3.56	37.46	100	198	Average
2437	108.44	115.28			27.06	3.56	37.46	100	198	Peak
2488	49.54	56.04	54	-4.46	27.2	3.62	37.32	100	198	Average
2488	62.84	69.34	74	-11.16	27.2	3.62	37.32	100	198	Peak
5150	49.3	50.01	54	-4.7	31.32	5.29	37.32	100	205	Average
5150	64.44	65.15	74	-9.56	31.32	5.29	37.32	100	205	Peak
5210	87.83	88.5			31.37	5.32	37.36	100	205	Average
5210	98.07	98.74			31.37	5.32	37.36	100	205	Peak
5386	38.93	39.2	54	-15.07	31.51	5.4	37.18	100	205	Average
5386	60.25	60.52	74	-13.75	31.51	5.4	37.18	100	205	Peak

**ANTENNA POLARITY & TEST DISTANCE: VERTICAL AT 3 M**

FREQ. (MHz)	EMISSION LEVEL (dBuV/m)	READ LEVEL (dBuV)	LIMIT (dBuV/m)	MARGIN (dB)	ANTENNA FACTOR (dB/m)	CABLE LOSS (dB)	PREAMP FACTOR (dB)	ANTENNA HEIGHT (cm)	TABLE ANGLE (Degree)	REMARK
2390	46.11	53.18	54	-7.89	26.91	3.54	37.52	105	196	Average
2390	61.05	68.12	74	-12.95	26.91	3.54	37.52	105	196	Peak
2437	100.09	106.93			27.06	3.56	37.46	105	196	Average
2437	109.56	116.4			27.06	3.56	37.46	105	196	Peak
2486	52.16	58.73	54	-1.84	27.15	3.6	37.32	105	196	Average
2486	62.67	69.24	74	-11.33	27.15	3.6	37.32	105	196	Peak
5150	51.39	52.1	54	-2.61	31.32	5.29	37.32	121	164	Average
5150	61.42	62.13	74	-12.58	31.32	5.29	37.32	121	164	Peak
5210	89.22	89.89			31.37	5.32	37.36	121	164	Average
5210	99.08	99.75			31.37	5.32	37.36	121	164	Peak
5400	39.25	39.5	54	-14.75	31.52	5.41	37.18	121	164	Average
5400	59.49	59.74	74	-14.51	31.52	5.41	37.18	121	164	Peak

**REMARKS:**

- Emission Level = Read Level + Antenna Factor + Cable Loss - Preamp Factor  
Margin value = Emission level – Limit value
- 2437MHz & 5210MHz: Fundamental frequency.



A D T

**MODE A**

**BELOW 1GHz WORST-CASE DATA:**

**802.11n (40MHz)**

EUT TEST CONDITION		MEASUREMENT DETAIL	
CHANNEL	Channel 6	FREQUENCY RANGE	30MHz ~ 1GHz
INPUT POWER	120Vac, 60 Hz	DETECTOR FUNCTION	Peak (PK)
ENVIRONMENTAL CONDITIONS	25deg. C, 65%RH	TESTED BY	Kay Wu

**ANTENNA POLARITY & TEST DISTANCE: HORIZONTAL AT 3 M**

FREQ. (MHz)	EMISSION LEVEL (dBuV/m)	READ LEVEL (dBuV)	LIMIT (dBuV/m)	MARGIN (dB)	ANTENNA FACTOR (dB/m)	CABLE LOSS (dB)	PREAMP FACTOR (dB)	ANTENNA HEIGHT (cm)	TABLE ANGLE (Degree)	REMARK
95.88	31.35	52.73	43.5	-12.15	9.38	1.28	32.04	132	111	Peak
163.11	33.91	54.07	43.5	-9.59	10.58	1.52	32.26	127	165	Peak
224.94	33.07	51.52	46	-12.93	11.9	1.85	32.2	102	37	Peak
374.9	37.98	51.57	46	-8.02	16.3	2.26	32.15	189	32	Peak
599.6	37.41	45.63	46	-8.59	21.1	2.87	32.19	153	138	Peak
875.4	31.22	34.56	46	-14.78	24.8	3.49	31.63	155	74	Peak

**ANTENNA POLARITY & TEST DISTANCE: VERTICAL AT 3 M**

FREQ. (MHz)	EMISSION LEVEL (dBuV/m)	READ LEVEL (dBuV)	LIMIT (dBuV/m)	MARGIN (dB)	ANTENNA FACTOR (dB/m)	CABLE LOSS (dB)	PREAMP FACTOR (dB)	ANTENNA HEIGHT (cm)	TABLE ANGLE (Degree)	REMARK
44.31	27.63	49.27	40	-12.37	9.68	0.9	32.22	187	94	Peak
94.26	32.16	53.72	43.5	-11.34	9.26	1.11	31.93	163	187	Peak
166.62	35.11	55.55	43.5	-8.39	10.29	1.52	32.25	177	21	Peak
374.9	31.54	45.13	46	-14.46	16.3	2.26	32.15	128	71	Peak
599.6	34.61	42.83	46	-11.39	21.1	2.87	32.19	145	113	Peak
870.5	35.99	39.62	46	-10.01	24.6	3.44	31.67	201	89	Peak

**REMARKS:** Emission Level = Read Level + Antenna Factor + Cable Loss - Preamp Factor

Margin value = Emission level – Limit value



A D T

**MODE B**

EUT TEST CONDITION		MEASUREMENT DETAIL	
CHANNEL	Channel 6	FREQUENCY RANGE	30MHz ~ 1GHz
INPUT POWER	120Vac, 60 Hz	DETECTOR FUNCTION	Peak (PK) Quasi Peak (QP)
ENVIRONMENTAL CONDITIONS	25deg. C, 65%RH	TESTED BY	Kay Wu

ANTENNA POLARITY & TEST DISTANCE: HORIZONTAL AT 3 M										
FREQ. (MHz)	EMISSION LEVEL (dBuV/m)	READ LEVEL (dBuV)	LIMIT (dBuV/m)	MARGIN (dB)	ANTENNA FACTOR (dB/m)	CABLE LOSS (dB)	PREAMP FACTOR (dB)	ANTENNA HEIGHT (cm)	TABLE ANGLE (Degree)	REMARK
70.23	36.1	59.1	40	-3.9	8.11	1.11	32.22	178	165	Peak
94.53	40.02	61.64	43.5	-3.48	9.26	1.11	31.99	164	81	QP
154.47	37.72	58.08	43.5	-5.78	10.39	1.52	32.27	124	35	Peak
374.9	30.94	44.53	46	-15.06	16.3	2.26	32.15	151	77	Peak
499.5	30.38	40.85	46	-15.62	19	2.63	32.1	117	93	Peak
599.6	33.09	41.31	46	-12.91	21.1	2.87	32.19	148	155	Peak
ANTENNA POLARITY & TEST DISTANCE: VERTICAL AT 3 M										
FREQ. (MHz)	EMISSION LEVEL (dBuV/m)	READ LEVEL (dBuV)	LIMIT (dBuV/m)	MARGIN (dB)	ANTENNA FACTOR (dB/m)	CABLE LOSS (dB)	PREAMP FACTOR (dB)	ANTENNA HEIGHT (cm)	TABLE ANGLE (Degree)	REMARK
70.23	39.67	62.67	40	-0.33	8.11	1.11	32.22	155	70	QP
98.31	43.15	64.48	43.5	-0.35	9.54	1.28	32.15	162	210	QP
162.03	37.44	57.53	43.5	-6.06	10.65	1.52	32.26	128	254	Peak
374.9	32.97	46.56	46	-13.03	16.3	2.26	32.15	145	166	Peak
599.6	34.14	42.36	46	-11.86	21.1	2.87	32.19	203	247	Peak
862.8	34.31	38.18	46	-11.69	24.4	3.44	31.71	158	76	Peak

**REMARKS:** Emission Level = Read Level + Antenna Factor + Cable Loss - Preamp Factor

Margin value = Emission level – Limit value



## 4.2 CONDUCTED EMISSION MEASUREMENT

### 4.2.1 LIMITS OF CONDUCTED EMISSION MEASUREMENT

FREQUENCY OF EMISSION (MHz)	CONDUCTED LIMIT (dB $\mu$ V)	
	Quasi-peak	Average
0.15 ~ 0.5	66 to 56	56 to 46
0.5 ~ 5	56	46
5 ~ 30	60	50

- NOTE:**
1. The lower limit shall apply at the transition frequencies.
  2. The limit decreases in line with the logarithm of the frequency in the range of 0.15 to 0.50MHz.
  3. All emanations from a class A/B digital device or system, including any network of conductors and apparatus connected thereto, shall not exceed the level of field strengths specified above.

### 4.2.2 TEST INSTRUMENTS

DESCRIPTION & MANUFACTURER	MODEL NO.	SERIAL NO.	DATE OF CALIBRATION	DUE DATE OF CALIBRATION
Test Receiver ROHDE & SCHWARZ	ESCS30	100288	Nov. 17, 2013	Nov. 16, 2014
RF signal cable Woken	5D-FB	Cable-HYCO2-01	Dec. 27, 2013	Dec. 26, 2014
LISN ROHDE & SCHWARZ (EUT)	ESH2-Z5	100100	Dec. 23, 2013	Dec. 22, 2014
LISN ROHDE & SCHWARZ (Peripheral)	ESH3-Z5	100312	Jul. 08, 2013	Jul. 07, 2014
Software ADT	BV ADT_Cond_ V7.3.7.3	NA	NA	NA

- NOTE:**
1. The calibration interval of the above test instruments is 12 months and the calibrations are traceable to NML/ROC and NIST/USA.
  2. The test was performed in HwaYa Shielded Room 2.
  3. The VCCI Site Registration No. is C-2047.

#### 4.2.3 TEST PROCEDURES

- a. The EUT was placed 0.4 meters from the conducting wall of the shielded room with EUT being connected to the power mains through a line impedance stabilization network (LISN). Other support units were connected to the power mains through another LISN. The two LISNs provide 50 ohm/ 50uH of coupling impedance for the measuring instrument.
- b. Both lines of the power mains connected to the EUT were checked for maximum conducted interference.
- c. The frequency range from 150kHz to 30MHz was searched. Emission levels under (Limit - 20dB) was not recorded.

**NOTE:** All modes of operation were investigated and the worst-case emissions are reported.

#### 4.2.4 DEVIATION FROM TEST STANDARD

No deviation.

#### 4.2.5 TEST SETUP

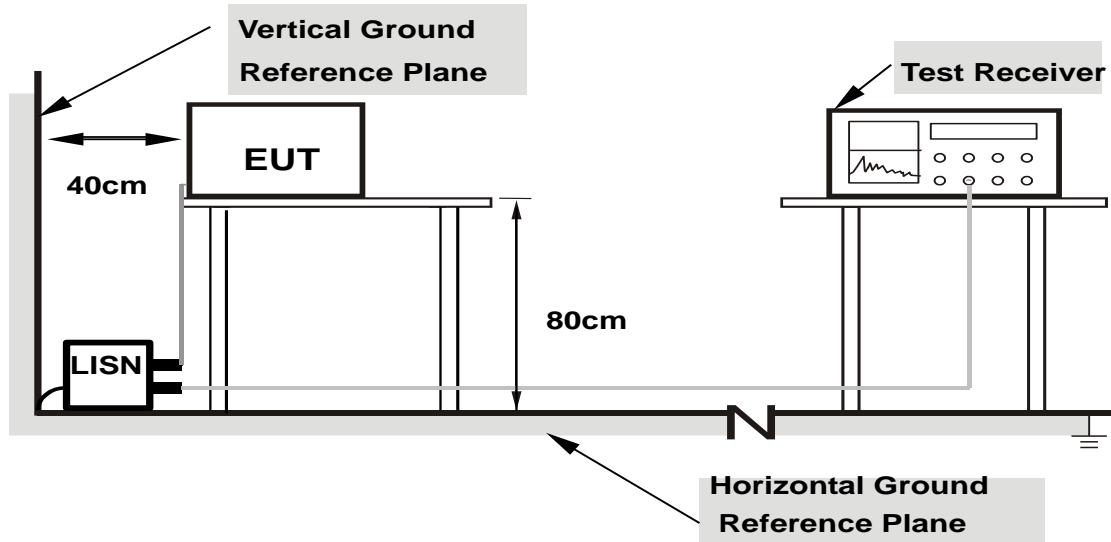

- Note:**
1. Support units were connected to second LISN.
  2. Both of LISNs (AMN) are 80 cm from EUT and at least 80 from other units and other metal planes

For the actual test configuration, please refer to the attached file (Test Setup Photo).

#### 4.2.6 EUT OPERATING CONDITIONS

Same as section 4.1.6

**4.2.7 TEST RESULTS**
**CONDUCTED WORST-CASE DATA :**
**MODE A**

Frequency Range	150kHz ~ 30MHz	Detector Function & Resolution Bandwidth	Quasi-Peak (QP), 9kHz Average (AV), 9kHz
Input Power	120Vac, 60Hz	Environmental Conditions	25°C, 65%RH
POWER SUPPLY	adapter		

Phase Of Power : Line (L)										
No	Frequency (MHz)	Correction Factor (dB)	Reading Value (dBuV)		Emission Level (dBuV)		Limit (dBuV)		Margin (dB)	
			Q.P.	AV.	Q.P.	AV.	Q.P.	AV.	Q.P.	AV.
1	0.18125	0.27	47.58	42.52	47.85	42.79	64.43	54.43	-16.57	-11.63
2	0.32188	0.29	43.36	31.03	43.65	31.32	59.66	49.66	-16.01	-18.34
3	0.46641	0.30	46.33	33.21	46.63	33.51	56.58	46.58	-9.94	-13.06
4	0.92344	0.33	38.00	26.25	38.33	26.58	56.00	46.00	-17.67	-19.42
5	1.38281	0.35	37.32	28.61	37.67	28.96	56.00	46.00	-18.33	-17.04
6	14.30078	0.53	25.75	19.81	26.28	20.34	60.00	50.00	-33.72	-29.66

**Remarks:**

1. Q.P. and AV. are abbreviations of quasi-peak and average individually.
2. The emission levels of other frequencies were very low against the limit.
3. Margin value = Emission level – Limit value
4. Correction factor = Insertion loss + Cable loss
5. Emission Level = Correction Factor + Reading Value

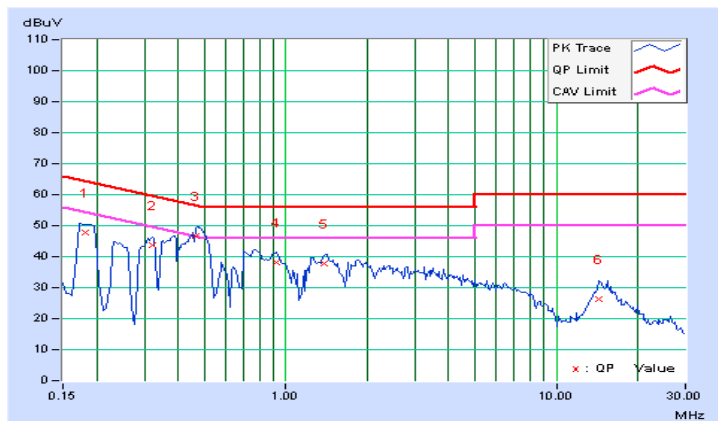



A D T

Frequency Range	150kHz ~ 30MHz	Detector Function & Resolution Bandwidth	Quasi-Peak (QP), 9kHz Average (AV), 9kHz
Input Power	120Vac, 60Hz	Environmental Conditions	25°C, 65%RH
POWER SUPPLY	adapter		

Phase Of Power : Neutral (N)										
No	Frequency (MHz)	Correction Factor (dB)	Reading Value (dBuV)		Emission Level (dBuV)		Limit (dBuV)		Margin (dB)	
			Q.P.	AV.	Q.P.	AV.	Q.P.	AV.	Q.P.	AV.
1	0.18125	0.27	45.63	39.91	45.90	40.18	64.43	54.43	-18.52	-14.24
2	0.47422	0.30	47.88	37.43	48.18	37.73	56.44	46.44	-8.25	-8.70
3	0.77109	0.32	39.11	29.60	39.43	29.92	56.00	46.00	-16.57	-16.08
4	1.39844	0.35	35.42	27.64	35.77	27.99	56.00	46.00	-20.23	-18.01
5	5.99609	0.47	25.44	20.97	25.91	21.44	60.00	50.00	-34.09	-28.56
6	15.00391	0.57	25.79	18.49	26.36	19.06	60.00	50.00	-33.64	-30.94

Remarks:

1. Q.P. and AV. are abbreviations of quasi-peak and average individually.
2. The emission levels of other frequencies were very low against the limit.
3. Margin value = Emission level – Limit value
4. Correction factor = Insertion loss + Cable loss
5. Emission Level = Correction Factor + Reading Value

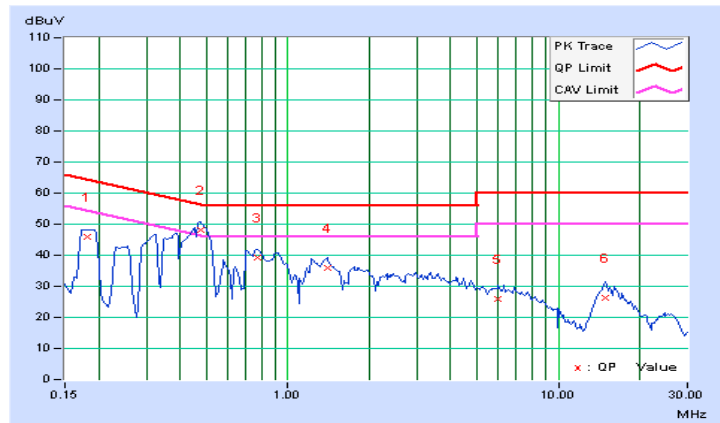



A D T

**MODE B**

Frequency Range	150kHz ~ 30MHz	Detector Function & Resolution Bandwidth	Quasi-Peak (QP), 9kHz Average (AV), 9kHz
Input Power	120Vac, 60Hz	Environmental Conditions	25°C, 65%RH
POWER SUPPLY	POE		

Phase Of Power : Line (L)										
No	Frequency (MHz)	Correction Factor (dB)	Reading Value (dBuV)		Emission Level (dBuV)		Limit (dBuV)		Margin (dB)	
			Q.P.	AV.	Q.P.	AV.	Q.P.	AV.	Q.P.	AV.
1	0.15391	0.27	58.42	42.38	58.69	42.65	65.79	55.79	-7.10	-13.14
2	0.32578	0.29	46.11	37.10	46.40	37.39	59.56	49.56	-13.16	-12.17
3	1.42969	0.35	30.33	23.64	30.68	23.99	56.00	46.00	-25.32	-22.01
4	3.44922	0.41	37.96	31.02	38.37	31.43	56.00	46.00	-17.63	-14.57
5	17.13281	0.56	23.69	19.94	24.25	20.50	60.00	50.00	-35.75	-29.50
6	29.58984	0.45	29.10	24.80	29.55	25.25	60.00	50.00	-30.45	-24.75

Remarks:

1. Q.P. and AV. are abbreviations of quasi-peak and average individually.
2. The emission levels of other frequencies were very low against the limit.
3. Margin value = Emission level – Limit value
4. Correction factor = Insertion loss + Cable loss
5. Emission Level = Correction Factor + Reading Value

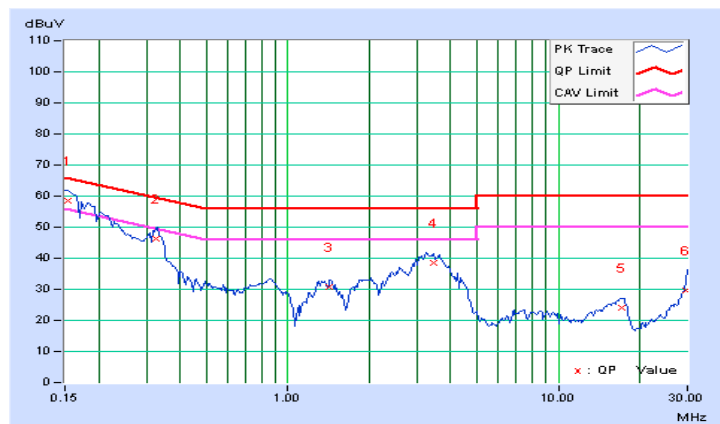



A D T

Frequency Range	150kHz ~ 30MHz	Detector Function & Resolution Bandwidth	Quasi-Peak (QP), 9kHz Average (AV), 9kHz
Input Power	120Vac, 60Hz	Environmental Conditions	25°C, 65%RH
POWER SUPPLY	POE		

Phase Of Power : Neutral (N)										
No	Frequency (MHz)	Correction Factor (dB)	Reading Value (dBuV)		Emission Level (dBuV)		Limit (dBuV)		Margin (dB)	
			Q.P.	AV.	Q.P.	AV.	Q.P.	AV.	Q.P.	AV.
1	0.15781	0.27	57.82	42.77	58.09	43.04	65.58	55.58	-7.49	-12.54
2	0.32188	0.29	43.92	33.16	44.21	33.45	59.66	49.66	-15.45	-16.21
3	0.87656	0.33	29.30	22.03	29.63	22.36	56.00	46.00	-26.37	-23.64
4	3.25391	0.41	38.89	32.00	39.30	32.41	56.00	46.00	-16.70	-13.59
5	16.83203	0.59	19.74	15.85	20.33	16.44	60.00	50.00	-39.67	-33.56
6	29.45703	0.46	26.42	22.42	26.88	22.88	60.00	50.00	-33.12	-27.12

Remarks:

1. Q.P. and AV. are abbreviations of quasi-peak and average individually.
2. The emission levels of other frequencies were very low against the limit.
3. Margin value = Emission level – Limit value
4. Correction factor = Insertion loss + Cable loss
5. Emission Level = Correction Factor + Reading Value

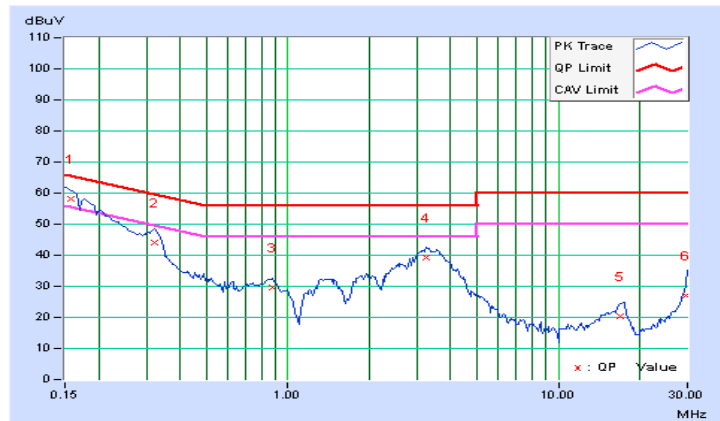

## 4.3 6dB BANDWIDTH MEASUREMENT

### 4.3.1 LIMITS OF 6dB BANDWIDTH MEASUREMENT

The minimum of 6dB Bandwidth Measurement is 0.5 MHz.

### 4.3.2 TEST SETUP

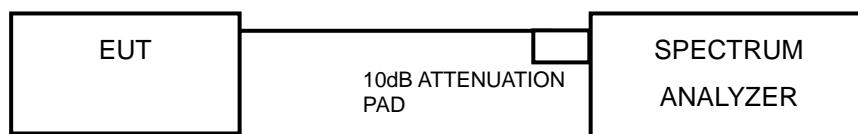

### 4.3.3 TEST INSTRUMENTS

Refer to section 4.1.2 to get information of above instrument.

### 4.3.4 TEST PROCEDURE

- Set resolution bandwidth (RBW) = 100kHz
- Set the video bandwidth (VBW)  $\geq 3 \times$  RBW, Detector = Peak.
- Trace mode = max hold.
- Sweep = auto couple.
- Measure the maximum width of the emission that is constrained by the frequencies associated with the two amplitude points (upper and lower) that are attenuated by 6 dB relative to the maximum level measured in the fundamental emission

### 4.3.5 DEVIATION FROM TEST STANDARD

No deviation.

### 4.3.6 EUT OPERATING CONDITIONS

The software provided by client to enable the EUT under transmission condition continuously at lowest, middle and highest channel frequencies individually.





A D T

#### 4.3.7 TEST RESULTS

##### 802.11b

CHANNEL	FREQUENCY (MHz)	6dB BANDWIDTH (MHz)	MINIMUM LIMIT (MHz)	PASS / FAIL
1	2412	6.54	0.5	PASS
6	2437	6.06	0.5	PASS
11	2462	6.06	0.5	PASS

##### 802.11g

CHANNEL	FREQUENCY (MHz)	6dB BANDWIDTH (MHz)	MINIMUM LIMIT (MHz)	PASS / FAIL
1	2412	16.39	0.5	PASS
6	2437	16.43	0.5	PASS
11	2462	16.39	0.5	PASS



A D T

### 802.11n (20MHz)

CHANNEL	FREQUENCY (MHz)	6dB BANDWIDTH (MHz)	MINIMUM LIMIT (MHz)	PASS / FAIL
1	2412	17.62	0.5	PASS
6	2437	17.65	0.5	PASS
11	2462	17.61	0.5	PASS

### FOR 2TX

CHANNEL	FREQUENCY (MHz)	6dB BANDWIDTH (MHz)		MINIMUM LIMIT (MHz)	PASS / FAIL
		CHAIN 0	CHAIN 1		
1	2412	17.61	17.62	0.5	PASS
6	2437	17.65	17.58	0.5	PASS
11	2462	17.64	17.65	0.5	PASS

### FOR 3TX

CHANNEL	FREQUENCY (MHz)	6dB BANDWIDTH (MHz)			MINIMUM LIMIT (MHz)	PASS / FAIL
		CHAIN 0	CHAIN 1	CHAIN 2		
1	2412	17.63	17.35	17.61	0.5	PASS
6	2437	17.63	17.63	17.65	0.5	PASS
11	2462	17.62	17.60	17.62	0.5	PASS



A D T

### 802.11n (40MHz)

CHANNEL	FREQUENCY (MHz)	6dB BANDWIDTH (MHz)	MINIMUM LIMIT (MHz)	PASS / FAIL
3	2422	36.41	0.5	PASS
6	2437	36.42	0.5	PASS
6	2452	36.13	0.5	PASS

### FOR 2TX

CHANNEL	FREQUENCY (MHz)	6dB BANDWIDTH (MHz)		MINIMUM LIMIT (MHz)	PASS / FAIL
		CHAIN 0	CHAIN 1		
3	2422	36.40	36.12	0.5	PASS
6	2437	36.37	36.38	0.5	PASS
9	2452	36.14	36.11	0.5	PASS

### FOR 3TX

CHANNEL	FREQUENCY (MHz)	6dB BANDWIDTH (MHz)			MINIMUM LIMIT (MHz)	PASS / FAIL
		CHAIN 0	CHAIN 1	CHAIN 2		
3	2422	36.42	36.36	36.36	0.5	PASS
6	2437	36.40	36.12	36.38	0.5	PASS
9	2452	36.34	36.37	36.11	0.5	PASS



A D T

### SPECTRUM PLOT OF WORST VALUE

#### 802.11b

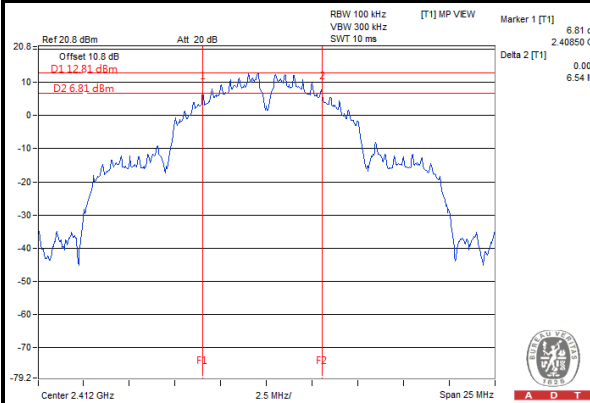

#### 802.11g

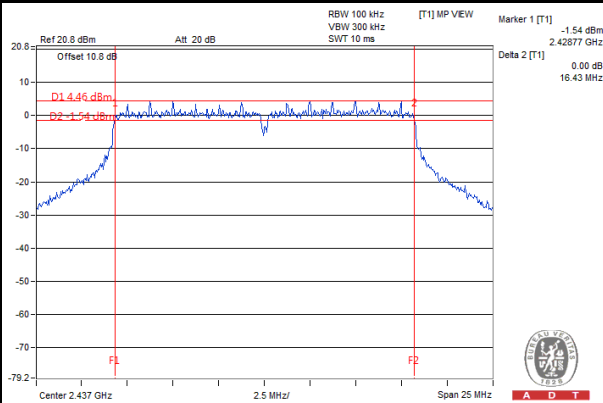

#### 802.11n (20MHz)

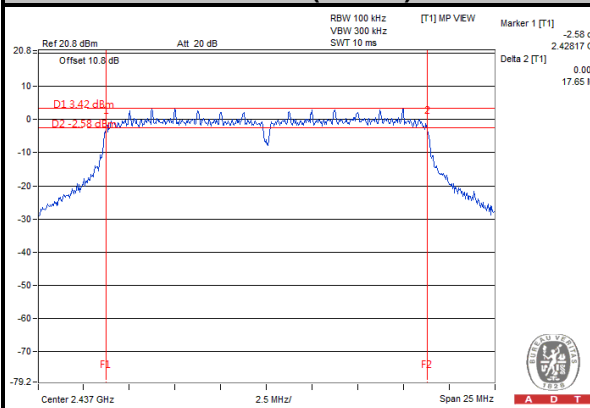

#### 802.11n (40MHz)

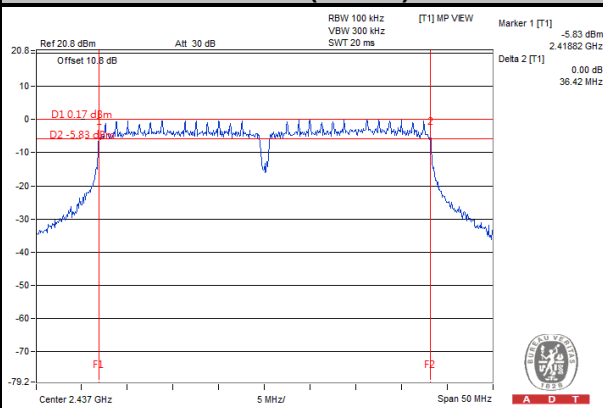

## 4.4 CONDUCTED OUTPUT POWER

### 4.4.1 LIMITS OF CONDUCTED OUTPUT POWER MEASUREMENT

For systems using digital modulation in the 2400–2483.5 MHz bands: 1 Watt (30dBm)

Per KDB 662911 D01 Multiple Transmitter Output v02r01 Method of conducted output power measurement on IEEE 802.11 devices,

Array Gain = 0 dB (i.e., no array gain) for  $NANT \leq 4$ ;

Array Gain = 0 dB (i.e., no array gain) for channel widths  $\geq 40$  MHz for any NANT;

Array Gain =  $5 \log(NANT/NSS)$  dB or 3 dB, whichever is less for 20-MHz channel widths with  $NANT \geq 5$ .

For power measurements on all other devices: Array Gain =  $10 \log(NANT/NSS)$  dB.

### 4.4.2 TEST SETUP

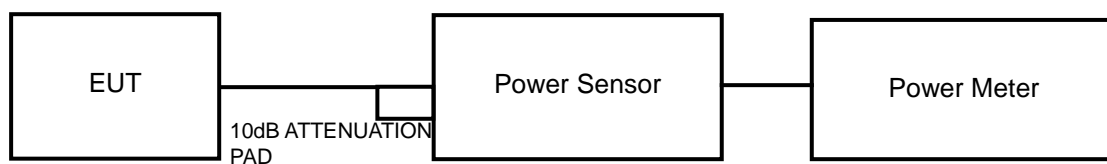

### 4.4.3 TEST INSTRUMENTS

Refer to section 4.1.2 to get information of above instrument.

### 4.4.4 TEST PROCEDURES

A peak power sensor was used on the output port of the EUT. A power meter was used to read the response of the peak power sensor. Record the peak power level.

### 4.4.5 DEVIATION FROM TEST STANDARD

No deviation.

### 4.4.6 EUT OPERATING CONDITIONS

Same as section 4.3.6.



A D T

#### 4.4.7 TEST RESULTS

##### 802.11b

CHANNEL	FREQUENCY (MHz)	PEAK POWER (mW)	PEAK POWER (dBm)	LIMIT (dBm)	PASS / FAIL
1	2412	244.91	23.89	30	PASS
6	2437	251.77	24.01	30	PASS
11	2462	248.31	23.95	30	PASS

##### 802.11g

CHANNEL	FREQUENCY (MHz)	PEAK POWER (mW)	PEAK POWER (dBm)	LIMIT (dBm)	PASS / FAIL
1	2412	408.32	26.11	30	PASS
6	2437	452.90	26.56	30	PASS
11	2462	427.56	26.31	30	PASS



A D T

### 802.11n (20MHz)

CHANNEL	FREQUENCY (MHz)	PEAK POWER (mW)	PEAK POWER (dBm)	LIMIT (dBm)	PASS / FAIL
1	2412	322.85	25.09	30	PASS
6	2437	389.94	25.91	30	PASS
11	2462	347.54	25.41	30	PASS

### FOR 2TX

CHAN.	FREQ. (MHz)	PEAK POWER (dBm)		TOTAL POWER (mW)	TOTAL POWER (dBm)	LIMIT (dBm)	PASS / FAIL
		CHAIN 0	CHAIN 1				
1	2412	26.06	25.29	741.710	28.70	30	PASS
6	2437	26.51	25.43	796.854	29.01	30	PASS
11	2462	26.23	25.58	781.169	28.93	30	PASS

### FOR 3TX

CHAN.	FREQ. (MHz)	PEAK POWER (dBm)			TOTAL POWER (mW)	TOTAL POWER (dBm)	LIMIT (dBm)	PASS / FAIL
		CHAIN 0	CHAIN 1	CHAIN 2				
1	2412	24.78	22.73	23.55	714.572	28.54	30	PASS
6	2437	24.83	22.65	23.97	737.625	28.68	30	PASS
11	2462	24.61	22.86	23.73	718.313	28.56	30	PASS



A D T

### 802.11n (40MHz)

CHANNEL	FREQUENCY (MHz)	PEAK POWER (mW)	PEAK POWER (dBm)	LIMIT (dBm)	PASS / FAIL
3	2422	189.23	22.77	30	PASS
6	2437	333.43	25.23	30	PASS
9	2452	274.79	24.39	30	PASS

### FOR 2TX

CHAN.	FREQ. (MHz)	PEAK POWER (dBm)		TOTAL POWER (mW)	TOTAL POWER (dBm)	LIMIT (dBm)	PASS / FAIL
		CHAIN 0	CHAIN 1				
3	2422	27.25	25.85	915.476	29.62	30	PASS
6	2437	27.41	26.11	959.127	29.82	30	PASS
9	2452	27.02	25.93	895.242	29.52	30	PASS

### FOR 3TX

CHAN.	FREQ. (MHz)	PEAK POWER (dBm)			TOTAL POWER (mW)	TOTAL POWER (dBm)	LIMIT (dBm)	PASS / FAIL
		CHAIN 0	CHAIN 1	CHAIN 2				
3	2422	23.12	22.09	21.41	505.281	27.04	30	PASS
6	2437	24.19	22.57	23.02	643.586	28.09	30	PASS
9	2452	23.21	21.19	21.45	480.571	26.82	30	PASS



## 4.5 POWER SPECTRAL DENSITY MEASUREMENT

### 4.5.1 LIMITS OF POWER SPECTRAL DENSITY MEASUREMENT

The Maximum of Power Spectral Density Measurement is 8dBm.

### 4.5.2 TEST SETUP

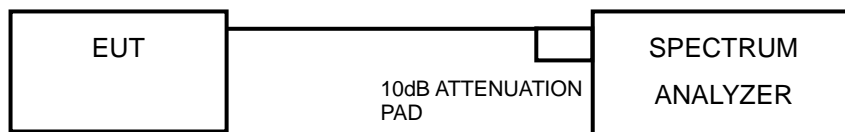

### 4.5.3 TEST INSTRUMENTS

Refer to section 4.1.2 to get information of above instrument.

### 4.5.4 TEST PROCEDURE

- Set the RBW = 3 kHz, VBW =10 kHz, Detector = peak.
- Sweep time = auto couple, Trace mode = max hold, allow trace to fully stabilize.
- Use the peak marker function to determine the maximum power level in any 100 kHz band segment within the fundamental EBW.

### 4.5.5 DEVIATION FROM TEST STANDARD

No deviation.

### 4.5.6 EUT OPERATING CONDITION

Same as section 4.3.6.



A D T

#### 4.5.7 TEST RESULTS

##### 802.11b

CHANNEL	FREQUENCY (MHz)	PSD (dBm/3kHz)	LIMIT (dBm/3kHz)	PASS / FAIL
1	2412	-1.72	8	PASS
6	2437	-1.10	8	PASS
11	2462	-2.00	8	PASS

##### 802.11g

CHANNEL	FREQUENCY (MHz)	PSD (dBm/3kHz)	LIMIT (dBm/3kHz)	PASS / FAIL
1	2412	-10.92	8	PASS
6	2437	-9.82	8	PASS
11	2462	-9.01	8	PASS



A D T

**802.11n (20MHz)**

CHANNEL	FREQUENCY (MHz)	PSD (dBm/3kHz)	LIMIT (dBm/3kHz)	PASS / FAIL
1	2412	-12.22	8	PASS
6	2437	-10.60	8	PASS
11	2462	-9.62	8	PASS

**FOR 2TX**

TX Chain	Channel	Freq. (MHz)	PSD (dBm/3kHz)	10 log (N=2) dB	Total PSD (dBm/3kHz)	Limit (dBm/3kHz)	PASS /FAIL
0	1	2412	-9.91	3.01	-6.90	8	PASS
	6	2437	-10.49	3.01	-7.48	8	PASS
	11	2462	-10.01	3.01	-7.00	8	PASS
1	1	2412	-11.45	3.01	-8.44	8	PASS
	6	2437	-12.28	3.01	-9.27	8	PASS
	11	2462	-11.05	3.01	-8.04	8	PASS

**NOTE:** Directional gain =  $10 \log[(10^{G1/20} + 10^{G2/20} + \dots + 10^{GN/20})^2 / N_{ANT}] = 5.94 < 6\text{dBi}$

**FOR 3TX**

TX Chain	Channel	Freq. (MHz)	PSD (dBm/3kHz)	10 log (N=3) dB	Total PSD (dBm/3kHz)	Limit (dBm/3kHz)	PASS /FAIL
0	1	2412	-12.38	4.77	-7.61	6.42	PASS
	6	2437	-12.36	4.77	-7.59	6.42	PASS
	11	2462	-12.33	4.77	-7.56	6.42	PASS
1	1	2412	-13.98	4.77	-9.21	6.42	PASS
	6	2437	-15.14	4.77	-10.37	6.42	PASS
	11	2462	-14.64	4.77	-9.87	6.42	PASS
2	1	2412	-13.82	4.77	-9.05	6.42	PASS
	6	2437	-14.30	4.77	-9.53	6.42	PASS
	11	2462	-13.08	4.77	-8.31	6.42	PASS

**NOTE:** Directional gain =  $10 \log[(10^{G1/20} + 10^{G2/20} + \dots + 10^{GN/20})^2 / N_{ANT}] = 7.58\text{dBi} > 6\text{dBi}$ , so the power density limit shall be reduced to  $8 - (7.58 - 6) = 6.42\text{dBm}$ .



A D T

**802.11n (40MHz)**

CHANNEL	FREQUENCY (MHz)	PSD (dBm/3kHz)	LIMIT (dBm/3kHz)	PASS / FAIL
3	2422	-16.42	8	PASS
6	2437	-11.86	8	PASS
9	2452	-15.82	8	PASS

**FOR 2TX**

TX Chain	Channel	Freq. (MHz)	PSD (dBm/3kHz)	10 log (N=2) dB	Total PSD (dBm/3kHz)	Limit (dBm/3kHz)	PASS /FAIL
0	3	2422	-11.65	3.01	-8.64	8	PASS
	6	2437	-10.56	3.01	-7.55	8	PASS
	9	2452	-10.78	3.01	-7.77	8	PASS
1	3	2422	-12.23	3.01	-9.22	8	PASS
	6	2437	-10.95	3.01	-7.94	8	PASS
	9	2452	-11.42	3.01	-8.41	8	PASS

**NOTE:** Directional gain =  $10 \log[(10^{G1/20} + 10^{G2/20} + \dots + 10^{GN/20})^2 / N_{ANT}] = 5.94 < 6\text{dBi}$

**FOR 3TX**

TX chain	Channel	Freq. (MHz)	PSD (dBm/3kHz)	10 log (N=3) dB	Total PSD (dBm/3kHz)	Limit (dBm/3kHz)	PASS /FAIL
0	3	2422	-17.22	4.77	-12.45	6.42	PASS
	6	2437	-15.02	4.77	-10.25	6.42	PASS
	9	2452	-14.38	4.77	-9.61	6.42	PASS
1	3	2422	-17.86	4.77	-13.09	6.42	PASS
	6	2437	-15.63	4.77	-10.86	6.42	PASS
	9	2452	-16.46	4.77	-11.69	6.42	PASS
2	3	2422	-17.30	4.77	-12.53	6.42	PASS
	6	2437	-14.73	4.77	-9.96	6.42	PASS
	9	2452	-16.93	4.77	-12.16	6.42	PASS

**NOTE:** Directional gain =  $10 \log[(10^{G1/20} + 10^{G2/20} + \dots + 10^{GN/20})^2 / N_{ANT}] = 7.58\text{dBi} > 6\text{dBi}$ , so the power density limit shall be reduced to  $8 - (7.58 - 6) = 6.42\text{dBm}$ .



A D T

### SPECTRUM PLOT OF WORST VALUE

#### 802.11b

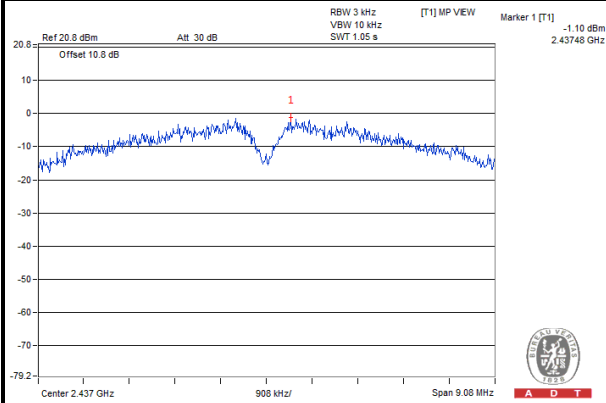

#### 802.11g

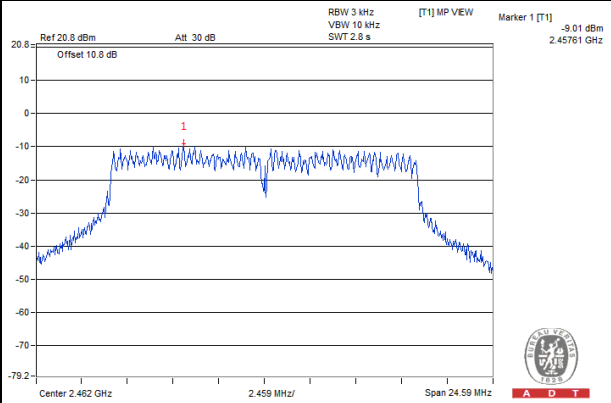

#### 802.11n (20MHz)

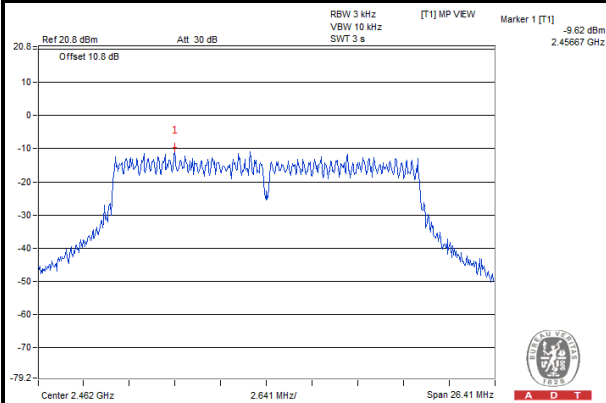

#### 802.11n (40MHz)

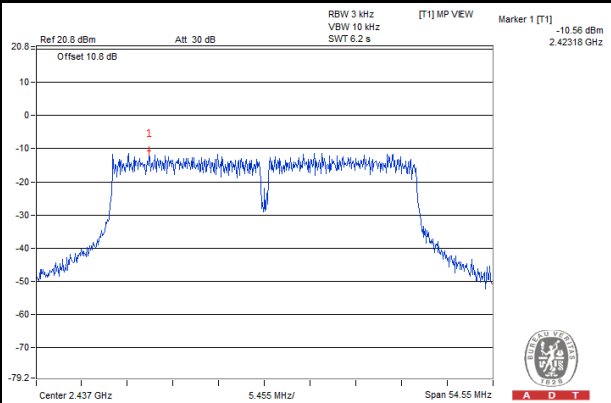

## 4.6 CONDUCTED OUT OF BAND EMISSION MEASUREMENT

### 4.6.1 LIMITS OF CONDUCTED OUT OF BAND EMISSION MEASUREMENT

Below  $-20\text{dB}$  of the highest emission level of operating band (in 100kHz Resolution Bandwidth).

### 4.6.2 TEST SETUP

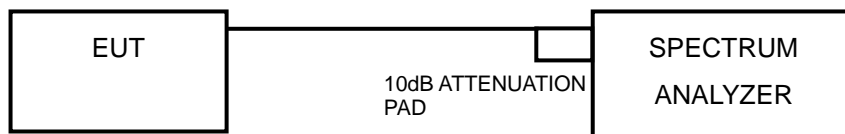

### 4.6.3 TEST INSTRUMENTS

Refer to section 4.1.2 to get information of above instrument.

### 4.6.4 TEST PROCEDURE

#### MEASUREMENT PROCEDURE REF

1. Set the RBW = 100 kHz.
2. Set the VBW  $\geq$  300 kHz.
3. Detector = peak.
4. Sweep time = auto couple.
5. Trace mode = max hold.
6. Allow trace to fully stabilize.
7. Use the peak marker function to determine the maximum power level in any 100 kHz band segment within the fundamental EBW.

#### MEASUREMENT PROCEDURE OOB

1. Set RBW = 100 kHz.
2. Set VBW  $\geq$  300 kHz.
3. Ensure that the number of measurement points  $\geq$  span/RBW
4. According to measurement points to set differ measurement span.
5. Detector = peak.
6. Trace Mode = max hold.
7. Sweep = auto couple.

### 4.6.5 DEVIATION FROM TEST STANDARD

No deviation.

### 4.6.6 EUT OPERATING CONDITION

Same as section 4.3.6.



A D T

### 4.6.7 TEST RESULTS

The spectrum plots are attached on the following images. D1 line indicates the highest level, and D2 line indicates the 20dB offset below D1. It shows compliance with the requirement.

#### 802.11b

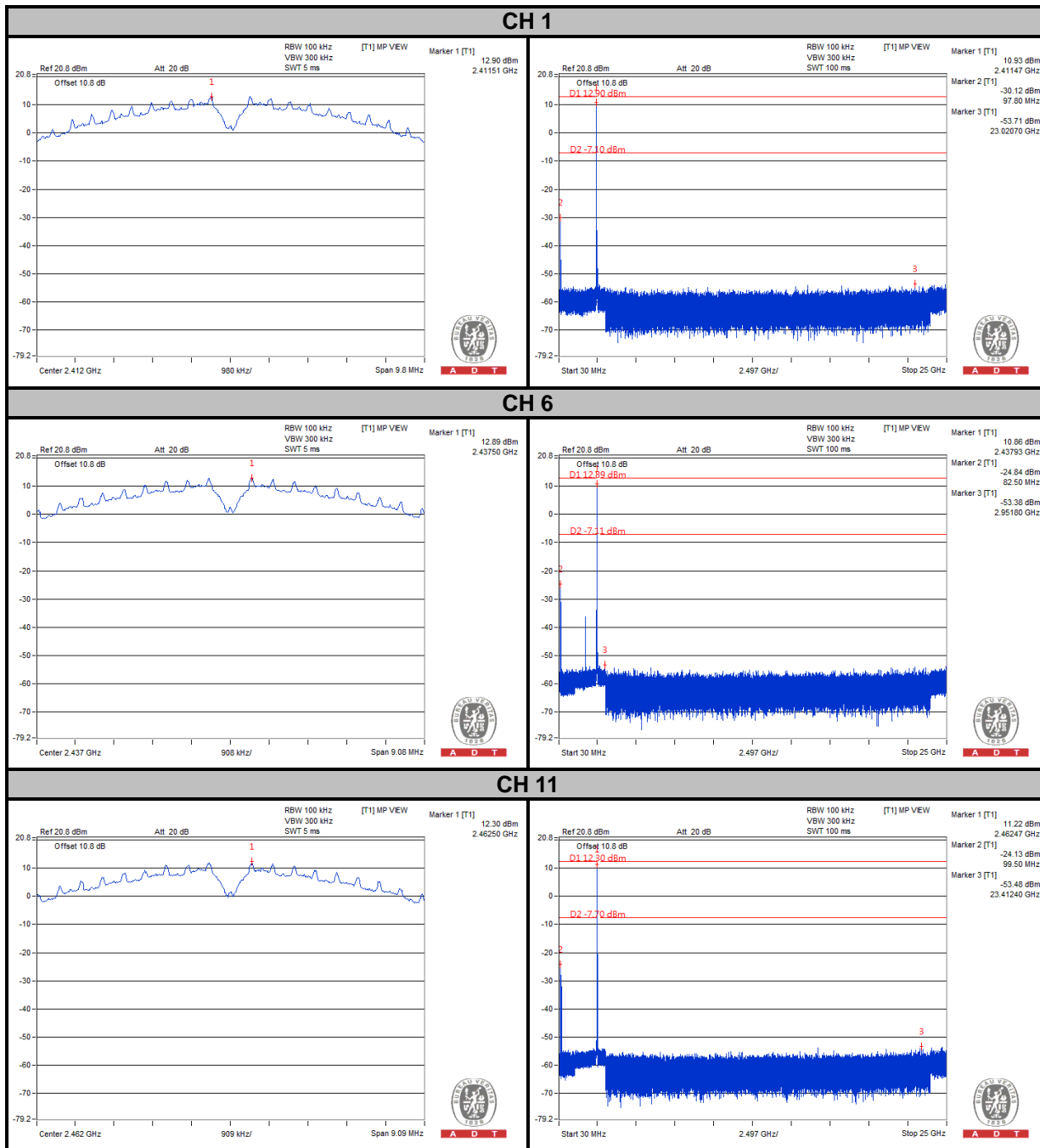



A D T

### 802.11g

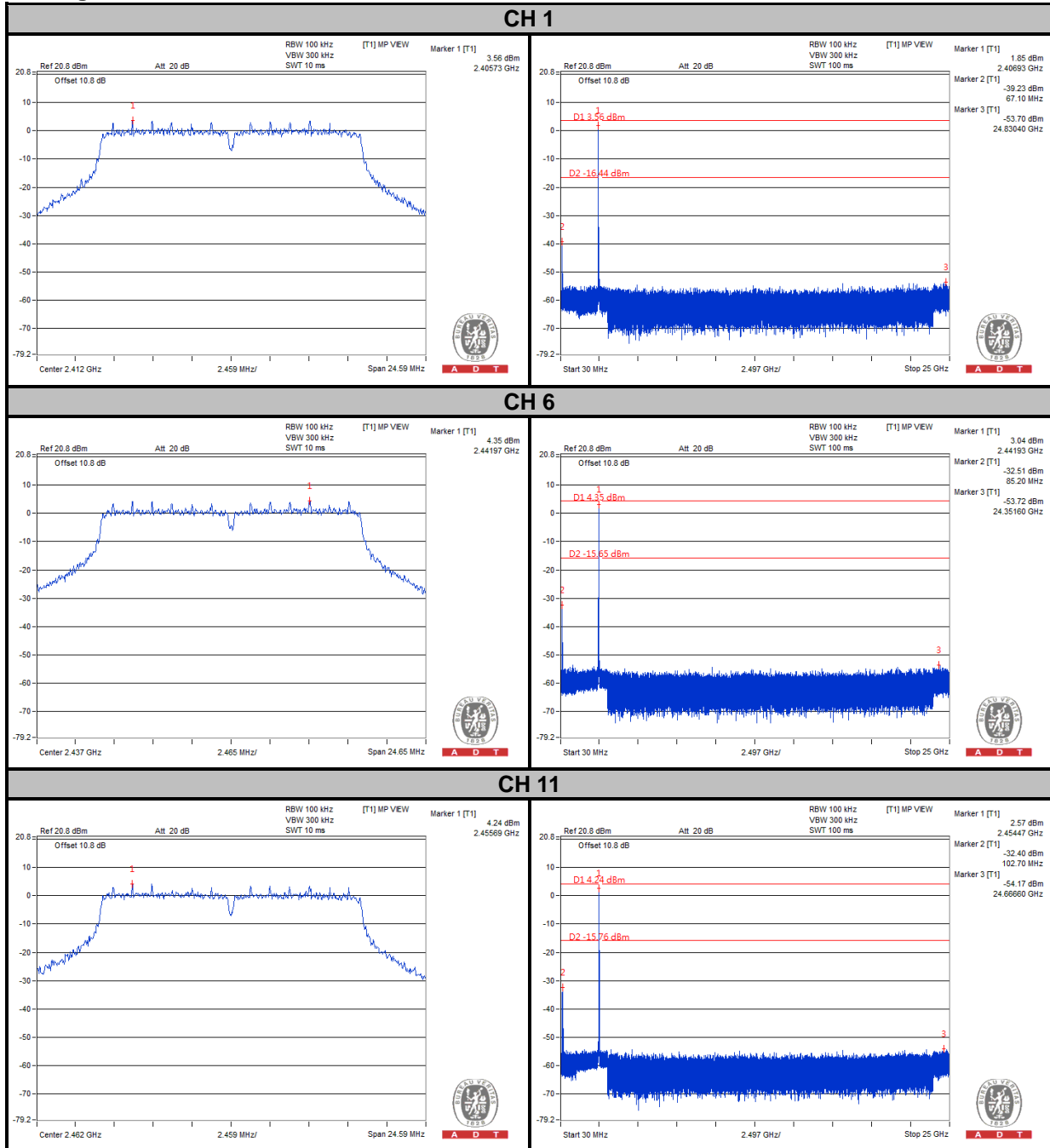





A D T

### 802.11n (20MHz)

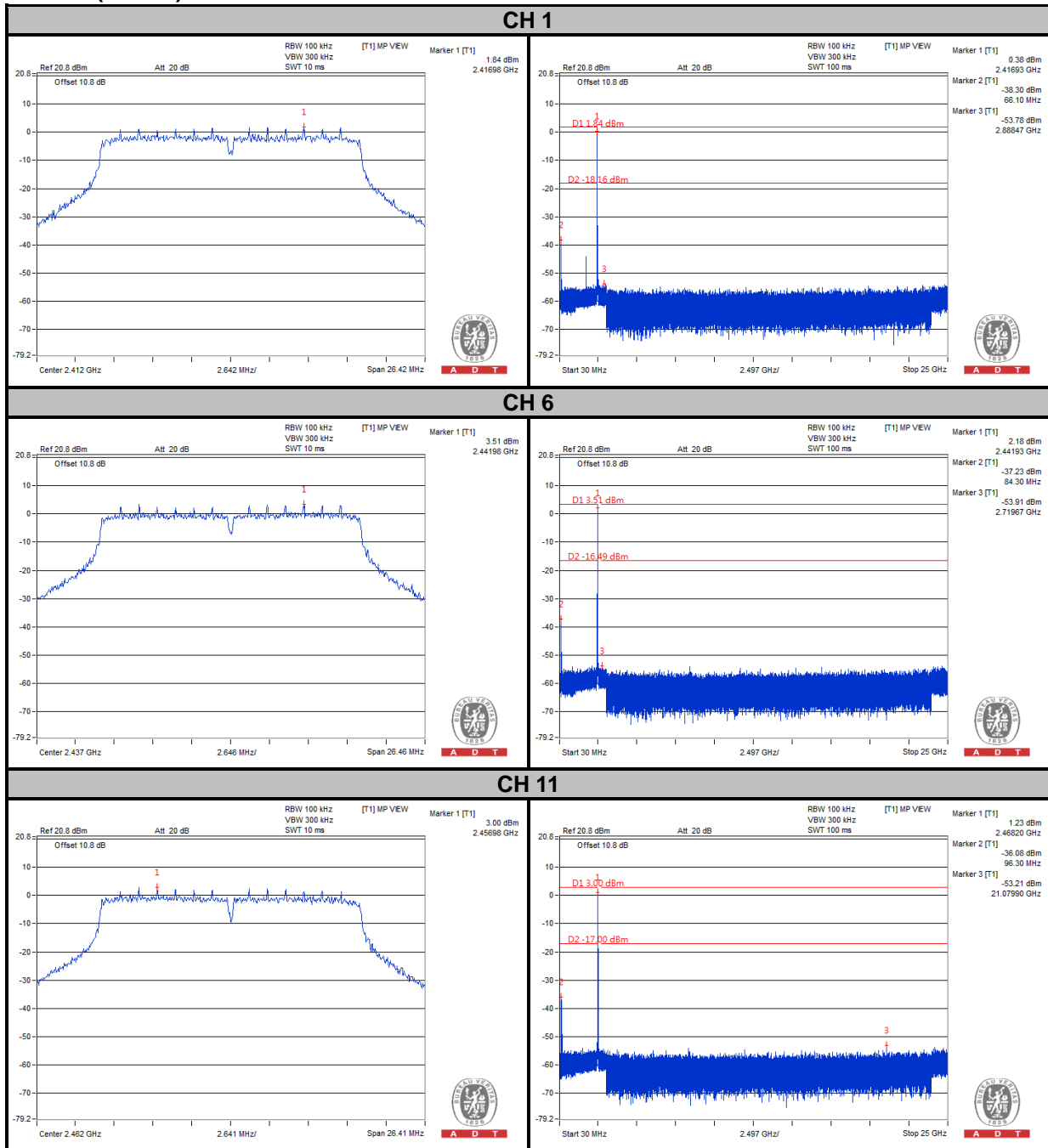



A D T

# 2TX CHAIN 0

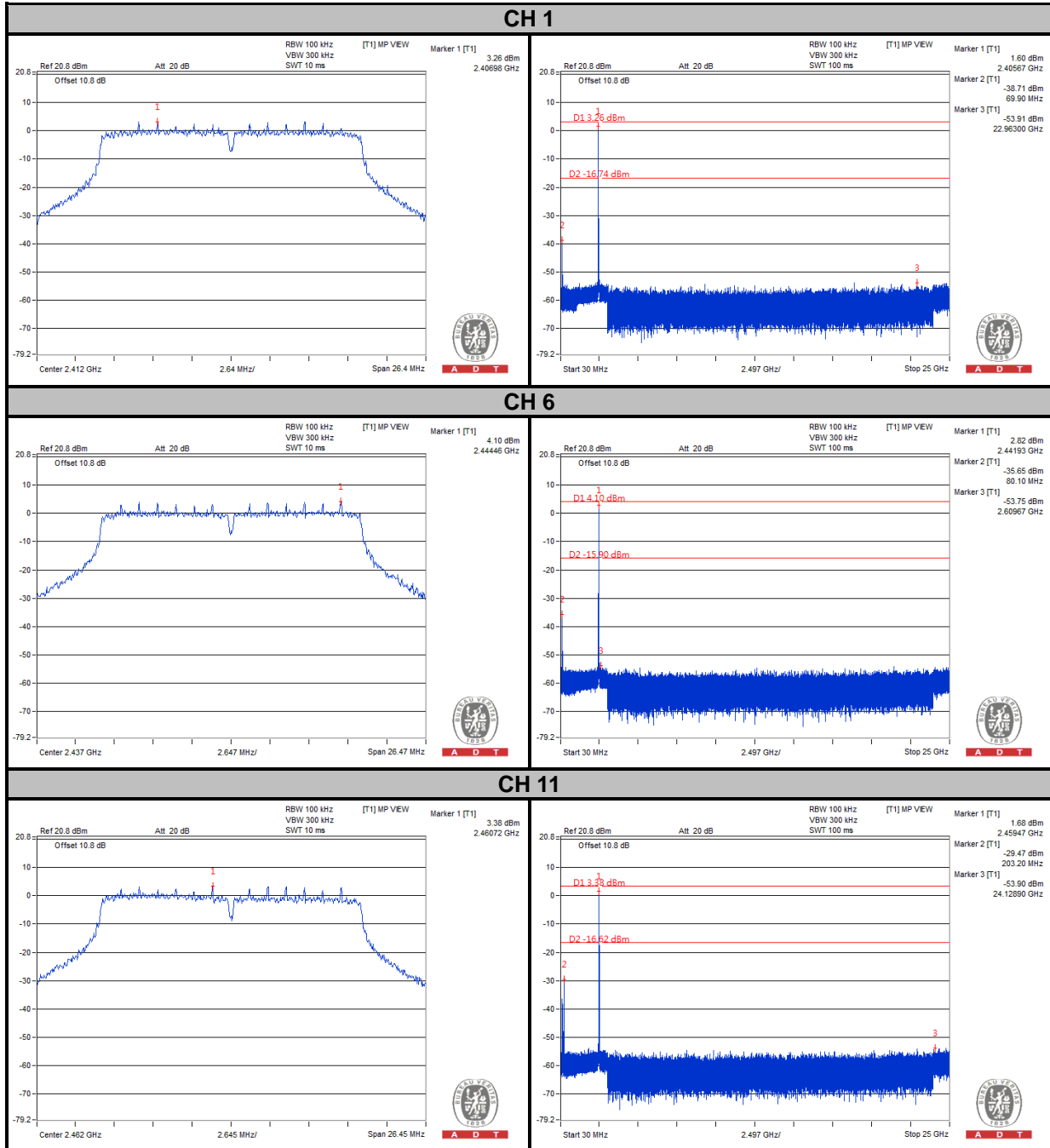



A D T

### CHAIN 1

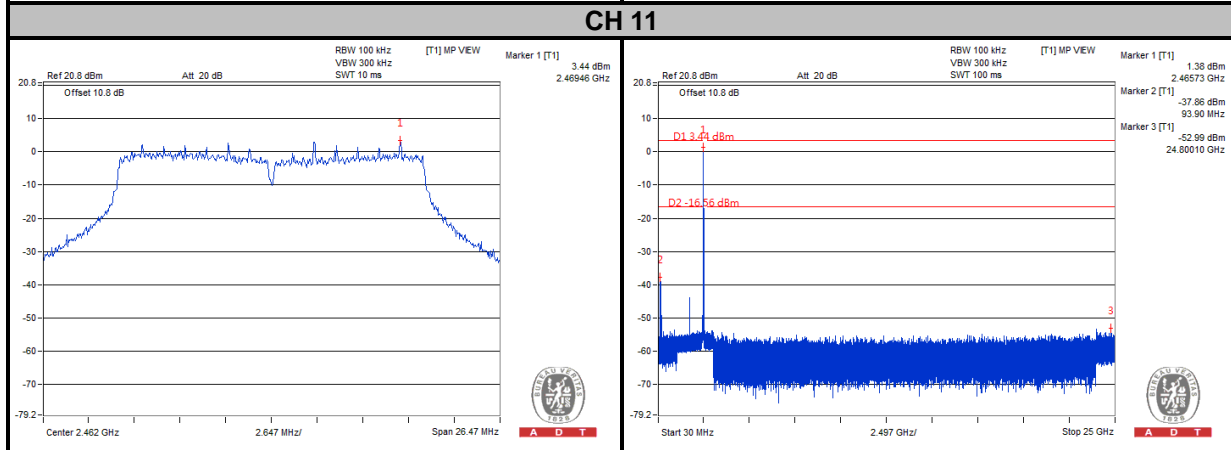
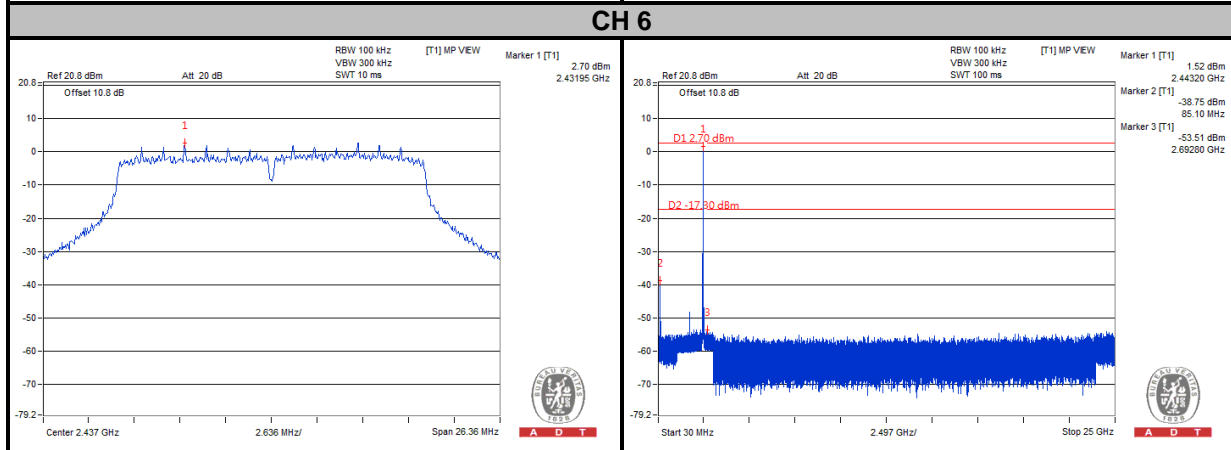
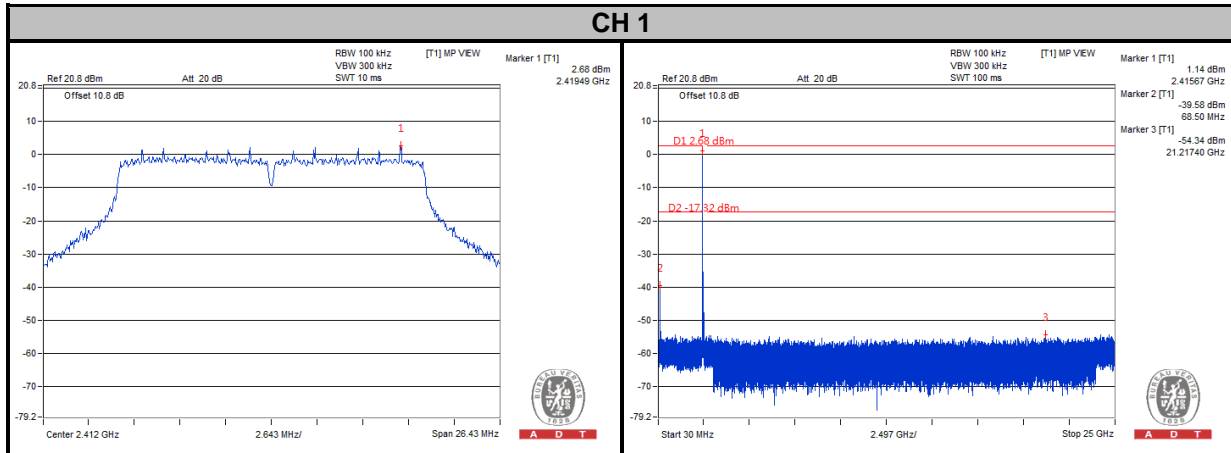



A D T

# 3TX CHAIN 0

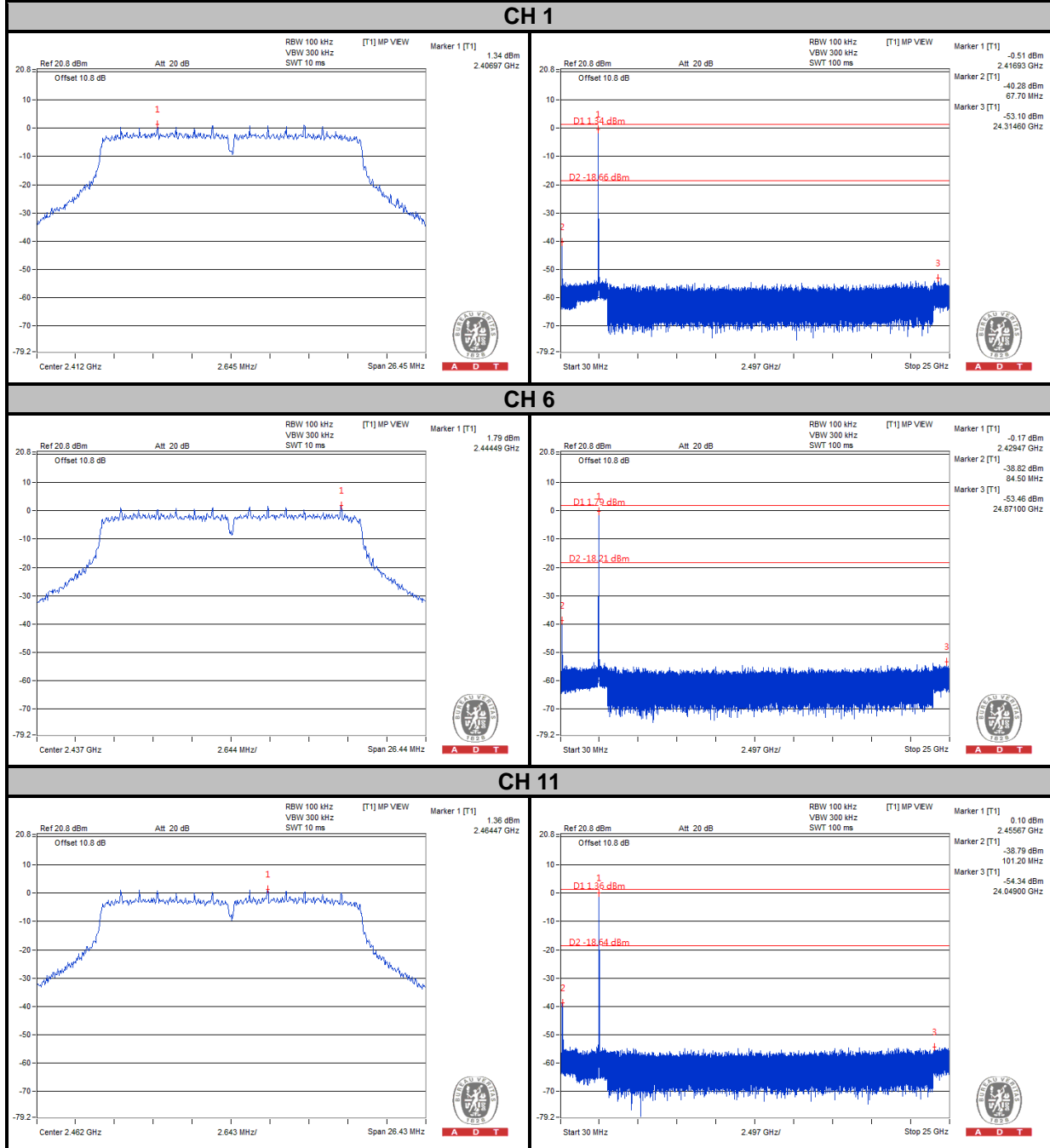



A D T

### CHAIN 1

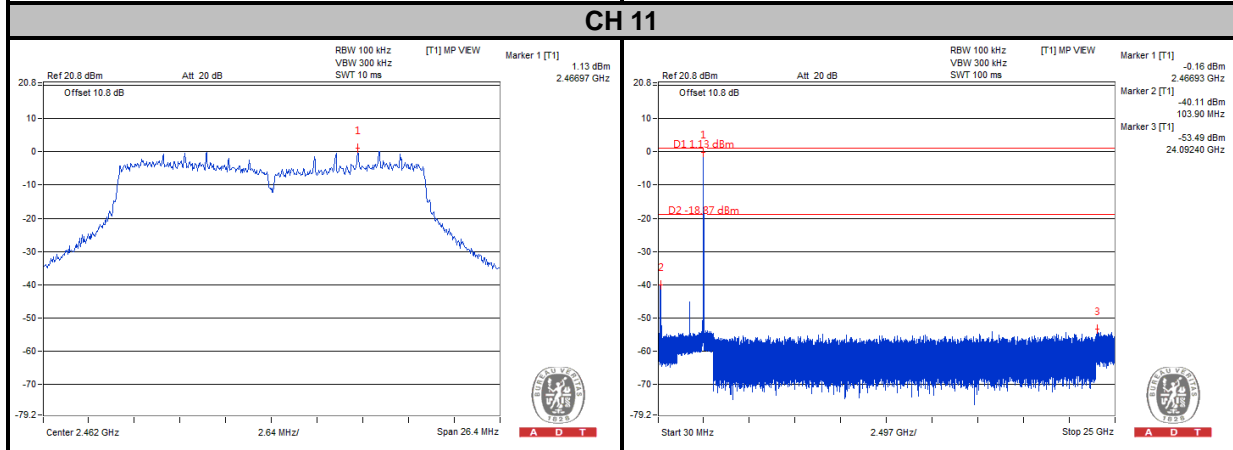
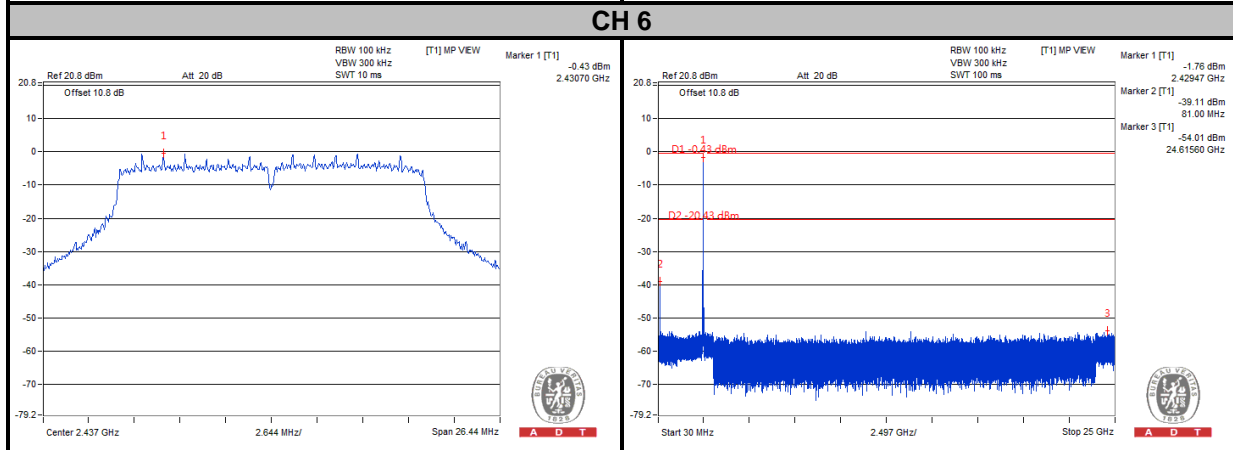
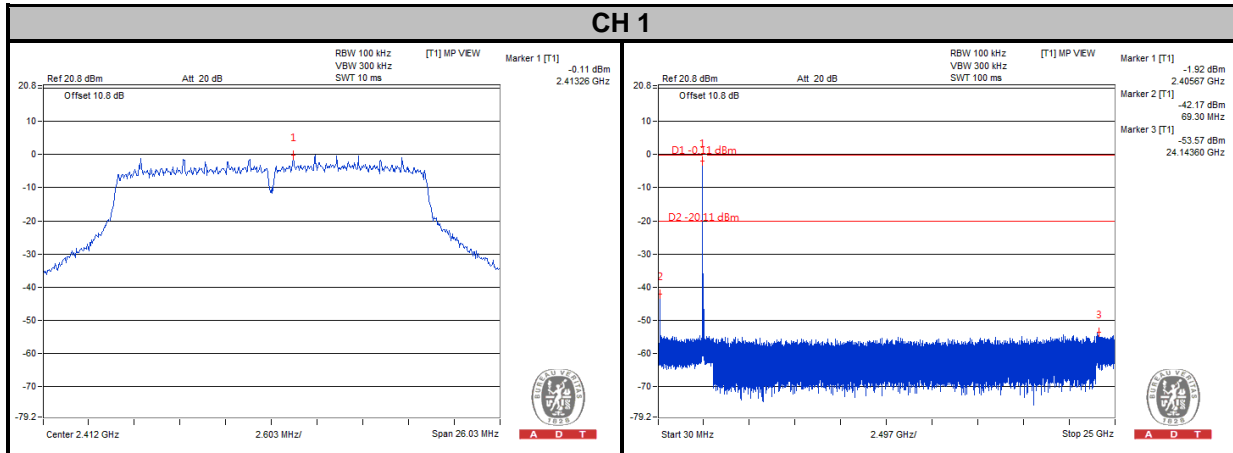



A D T

### CHAIN 2

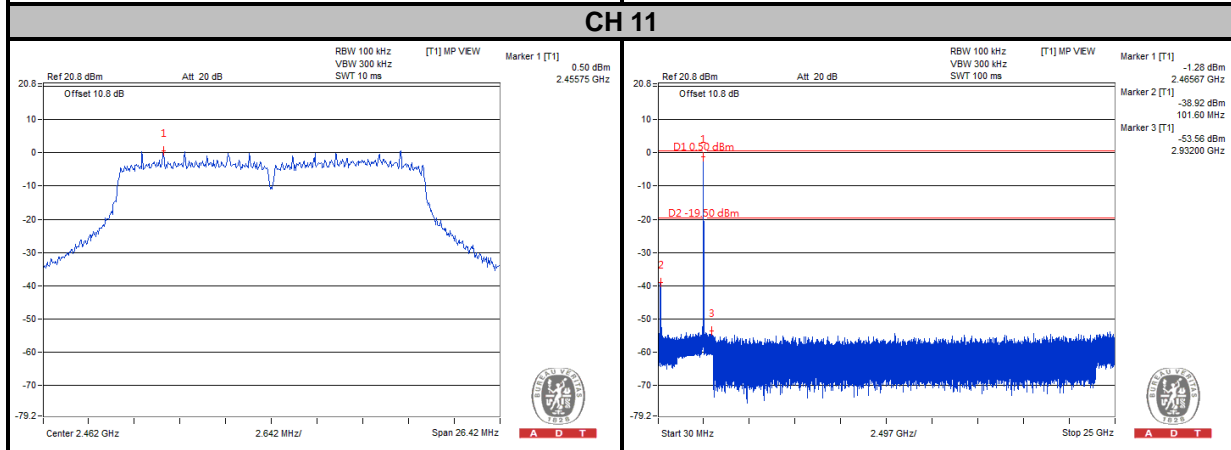
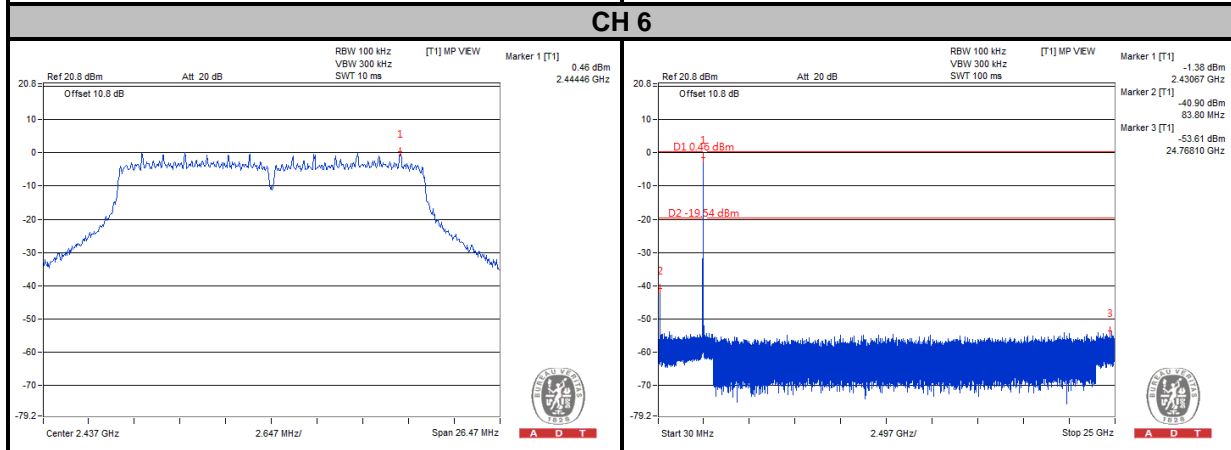
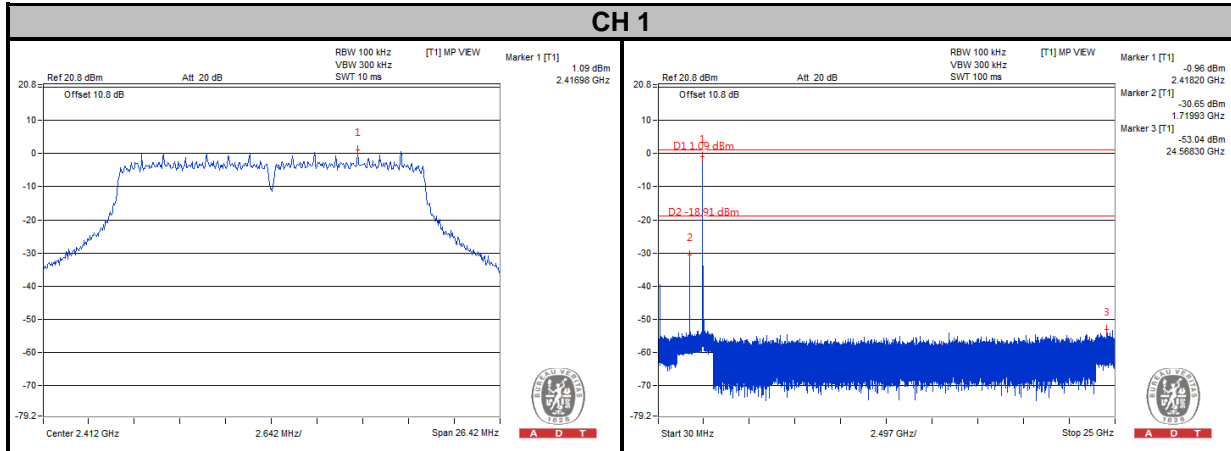



A D T

### 802.11n (40MHz)

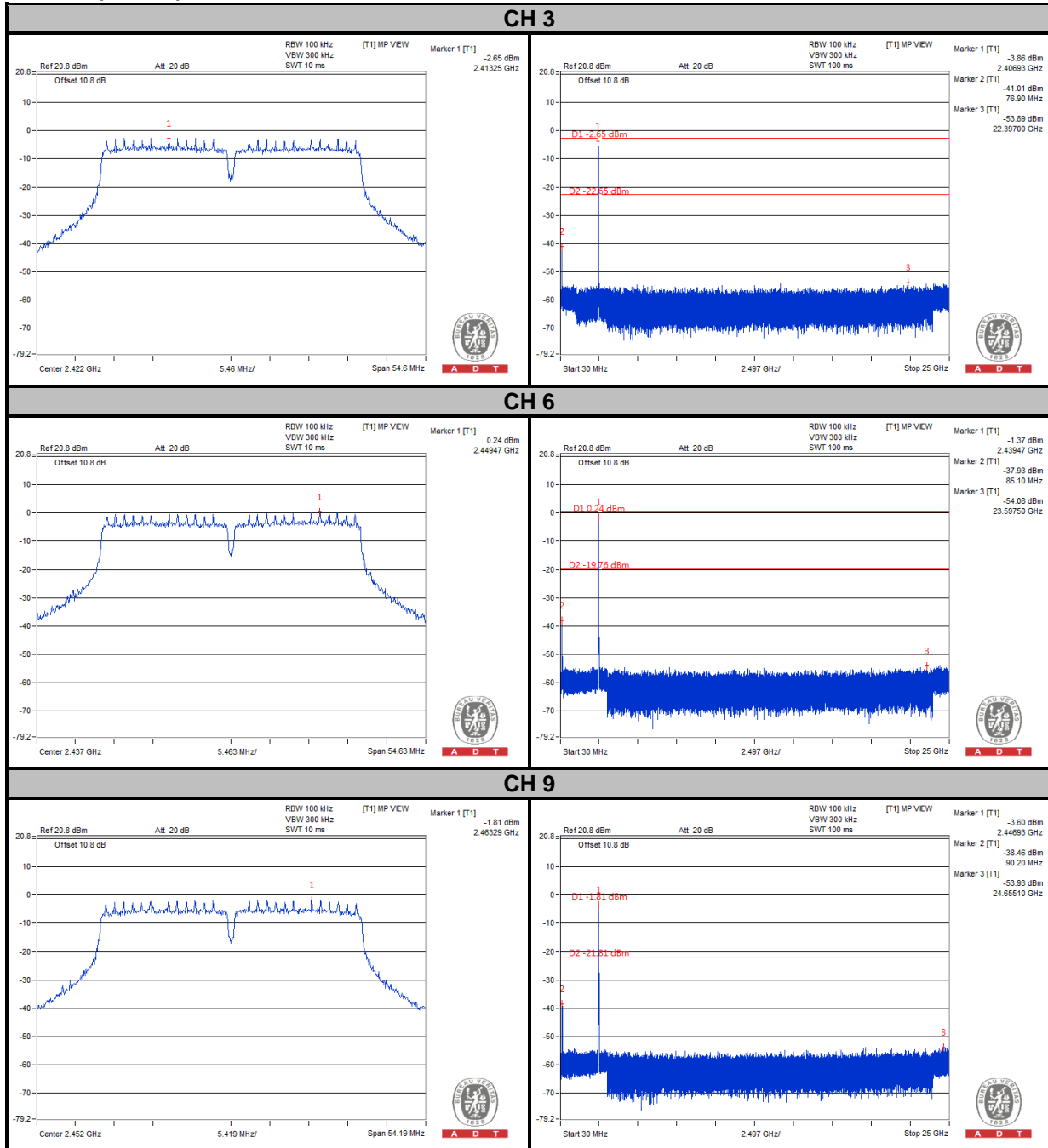



A D T

# 2TX CHAIN 0

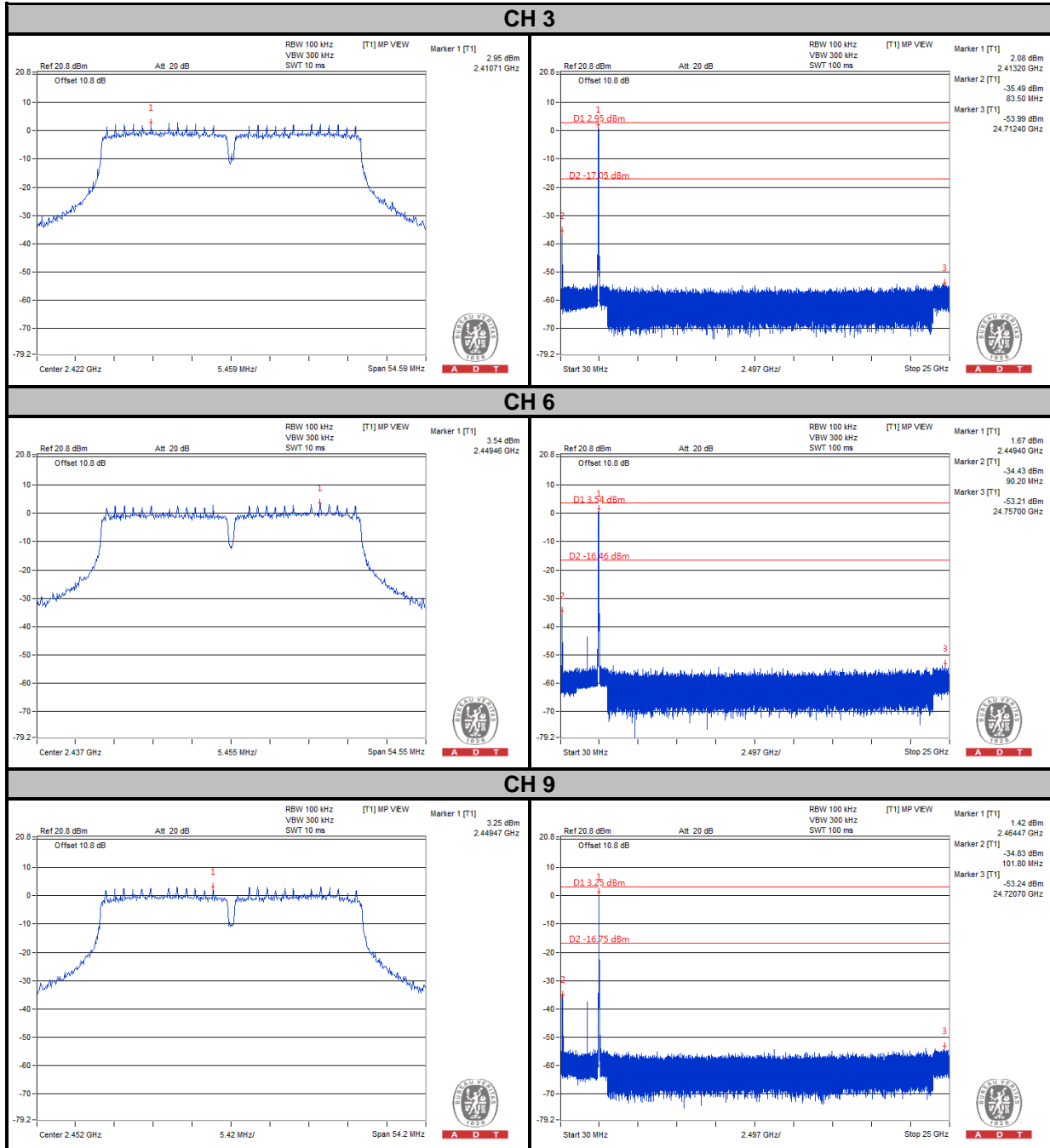





A D T

### CHAIN 1

#### CH 3

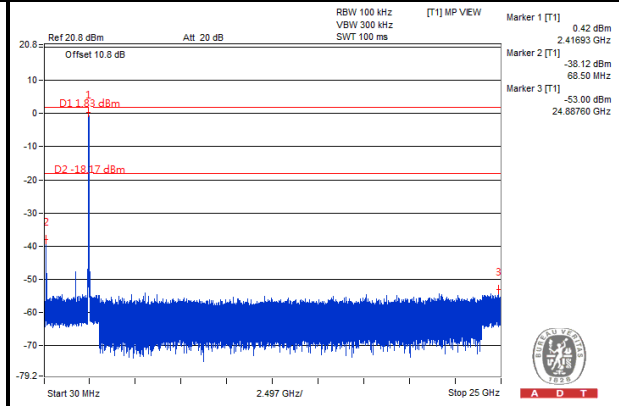
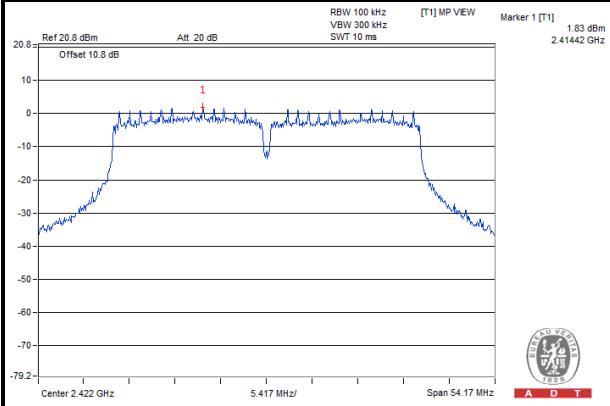

#### CH 6

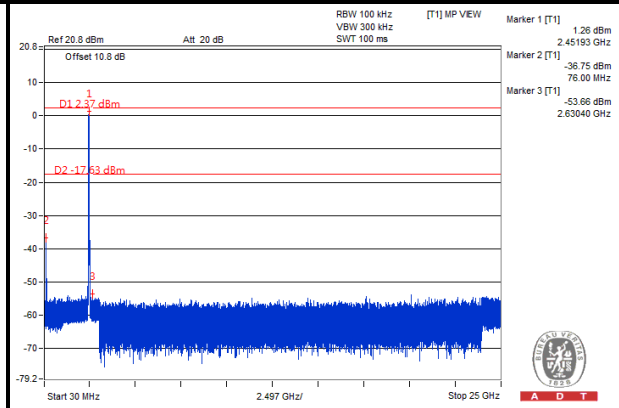
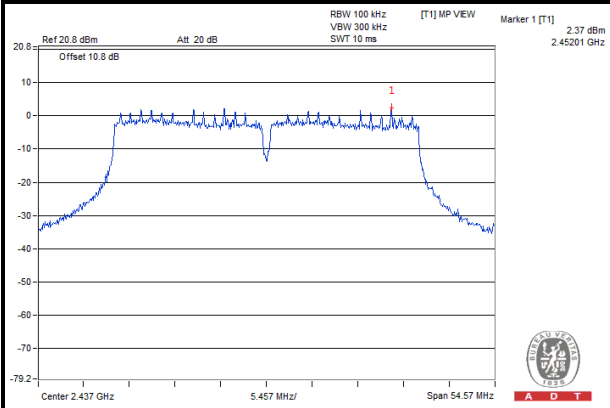

#### CH 9

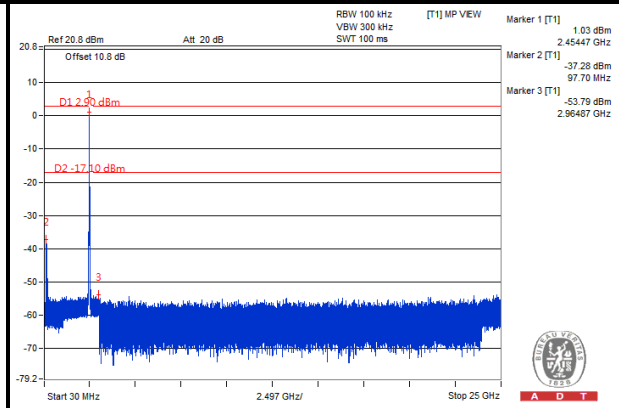
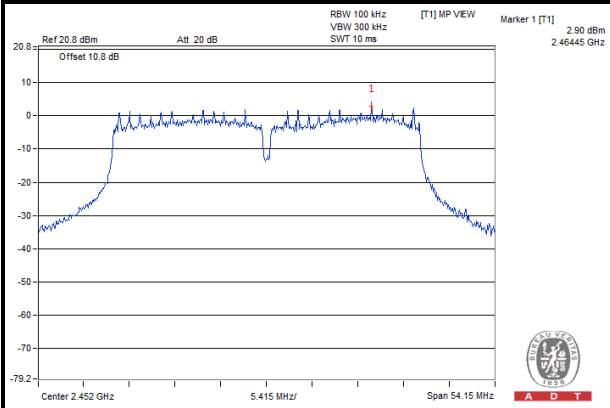



A D T

### 3TX CHAIN 0

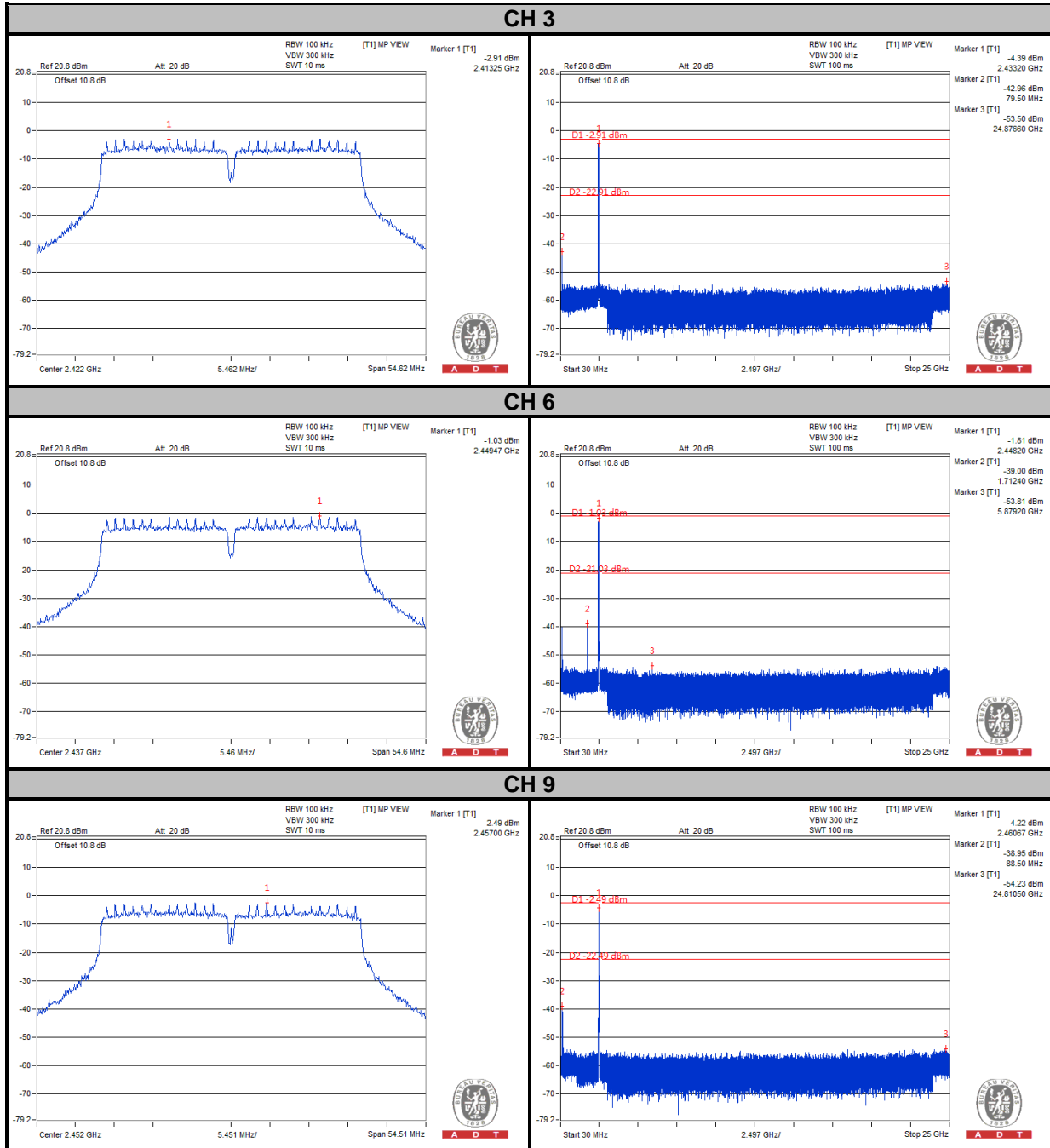



A D T

### CHAIN 1

#### CH 3

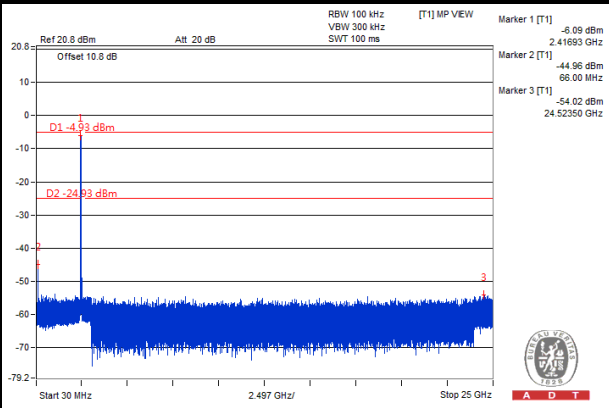
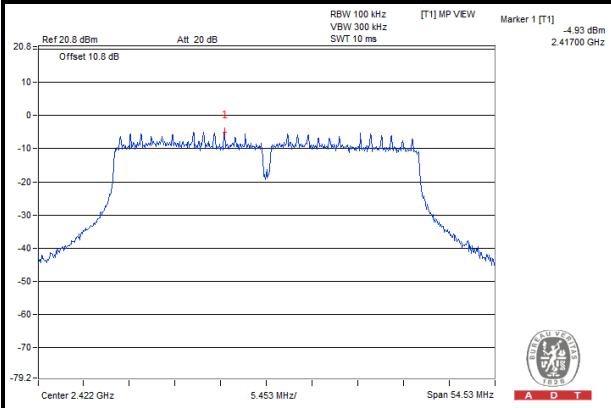

#### CH 6

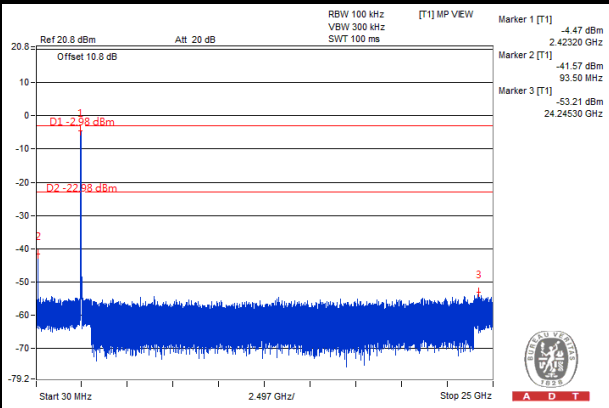
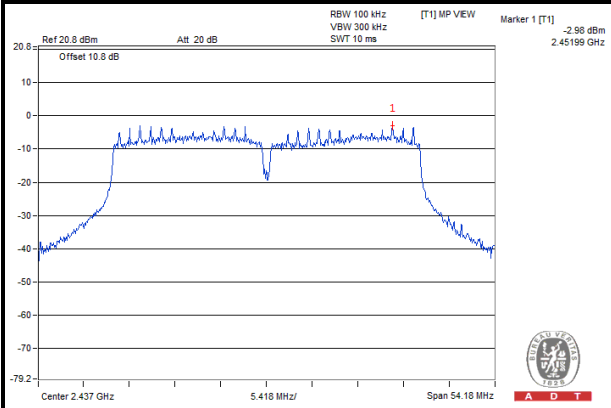

#### CH 9

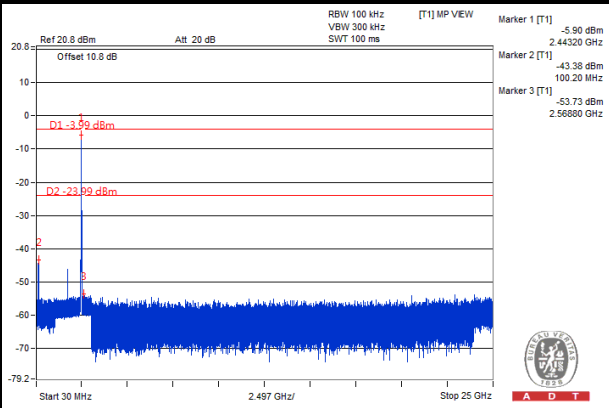
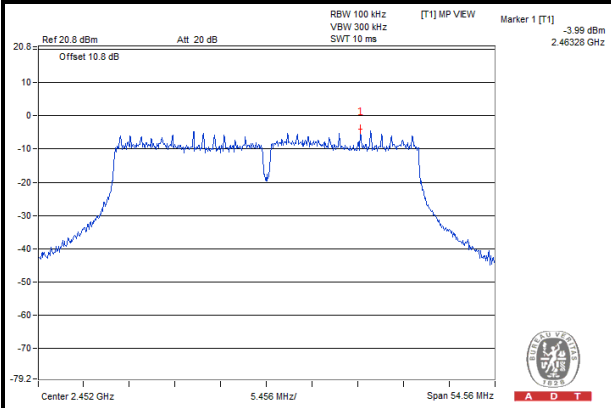



A D T

## CHAIN 2

### CH 3

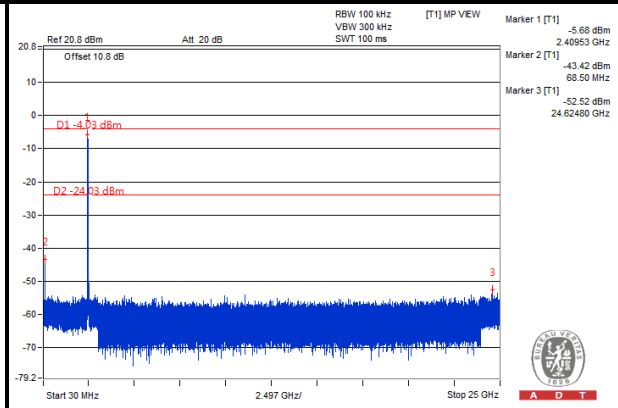
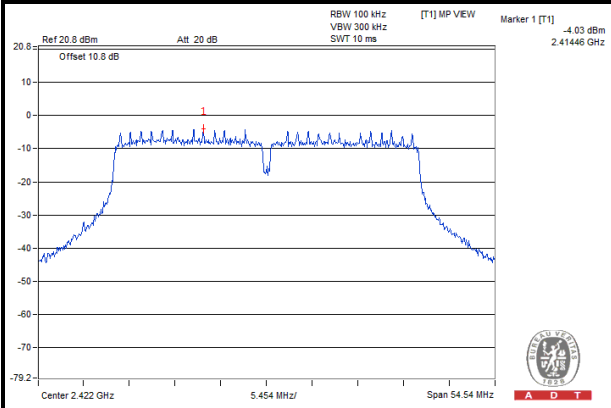

### CH 6

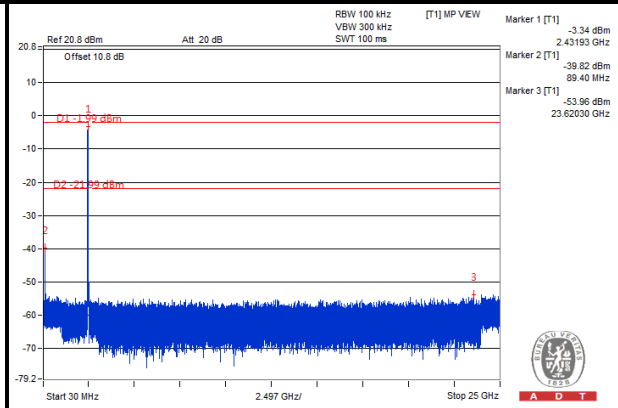
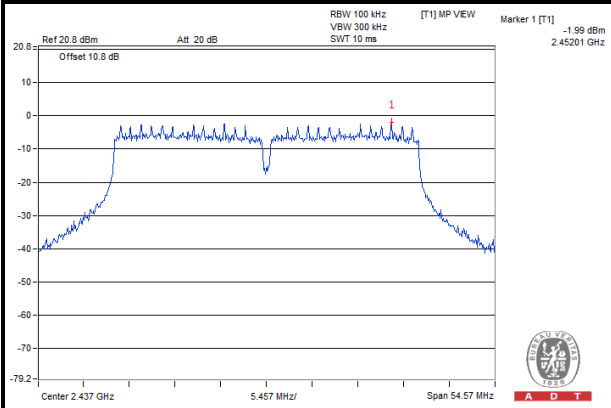

### CH 9

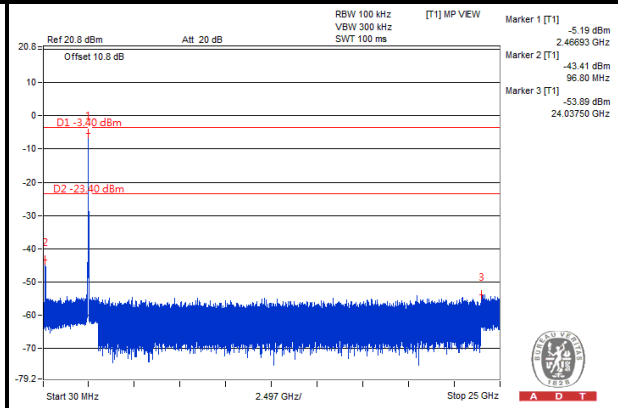
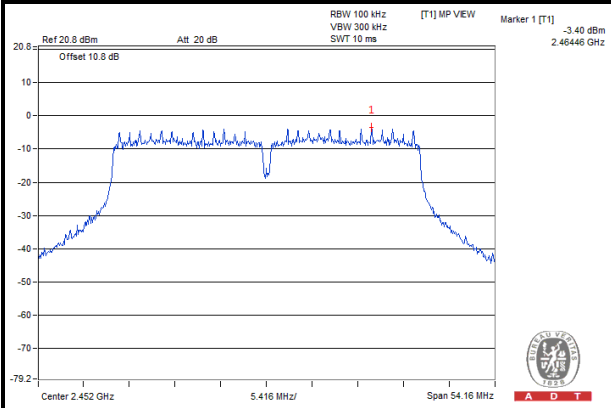

## 5. TEST TYPES AND RESULTS (FOR 5.0GHz BAND)

### 5.1 RADIATED EMISSION AND BANDEDGE MEASUREMENT

#### 5.1.1 LIMITS OF RADIATED EMISSION AND BANDEDGE MEASUREMENT

Radiated emissions which fall in the restricted bands must comply with the radiated emission limits specified as below table. Other emissions shall be at least 20dB below the highest level of the desired power:

FREQUENCIES (MHz)	FIELD STRENGTH (microvolts/meter)	MEASUREMENT DISTANCE (meters)
0.009 ~ 0.490	2400/F(kHz)	300
0.490 ~ 1.705	24000/F(kHz)	30
1.705 ~ 30.0	30	30
30 ~ 88	100	3
88 ~ 216	150	3
216 ~ 960	200	3
Above 960	500	3

**NOTE:**

1. The lower limit shall apply at the transition frequencies.
2. Emission level (dBuV/m) = 20 log Emission level (uV/m).
3. For frequencies above 1000MHz, the field strength limits are based on average detector, however, the peak field strength of any emission shall not exceed the maximum permitted average limits, specified above by more than 20dB under any condition of modulation.



A D T

### **5.1.2 TEST INSTRUMENTS**

Same as section 4.1.2.

### **5.1.3 TEST PROCEDURES**

Same as section 4.1.3.

### **5.1.4 DEVIATION FROM TEST STANDARD**

No deviation.

### **5.1.5 TEST SETUP**

Same as section 4.1.5.

### **5.1.6 EUT OPERATING CONDITIONS**

Same as section 4.1.6.



A D T

5.1.7 TEST RESULTS

MODE A (1TX)

ABOVE 1GHz WORST-CASE DATA :

802.11a

EUT TEST CONDITION		MEASUREMENT DETAIL	
CHANNEL	Channel 149	FREQUENCY RANGE	1GHz ~ 40GHz
INPUT POWER	120Vac, 60 Hz	DETECTOR FUNCTION	Peak (PK) Average (AV)
ENVIRONMENTAL CONDITIONS	25deg. C, 65%RH	TESTED BY	Kay Wu

ANTENNA POLARITY & TEST DISTANCE: HORIZONTAL AT 3 M										
FREQ. (MHz)	EMISSION LEVEL (dBuV/m)	READ LEVEL (dBuV)	LIMIT (dBuV/m)	MARGIN (dB)	ANTENNA FACTOR (dB/m)	CABLE LOSS (dB)	PREAMP FACTOR (dB)	ANTENNA HEIGHT (cm)	TABLE ANGLE (Degree)	REMARK
5725	52.88	43.72	83.55	-30.67	34.62	8.65	34.11	112	194	Average
5725	70.93	61.77	91.3	-20.37	34.62	8.65	34.11	112	194	Peak
5745	103.55	94.36			34.64	8.66	34.11	112	194	Average
5745	111.3	102.11			34.64	8.66	34.11	112	194	Peak
5850	44.75	35.45	83.55	-38.8	34.74	8.7	34.14	112	194	Average
5850	62.36	53.06	91.3	-28.94	34.74	8.7	34.14	112	194	Peak
ANTENNA POLARITY & TEST DISTANCE: VERTICAL AT 3 M										
FREQ. (MHz)	EMISSION LEVEL (dBuV/m)	READ LEVEL (dBuV)	LIMIT (dBuV/m)	MARGIN (dB)	ANTENNA FACTOR (dB/m)	CABLE LOSS (dB)	PREAMP FACTOR (dB)	ANTENNA HEIGHT (cm)	TABLE ANGLE (Degree)	REMARK
5725	61.41	52.25	90.29	-28.88	34.62	8.65	34.11	102	247	Average
5725	76.41	67.25	96.9	-20.49	34.62	8.65	34.11	102	247	Peak
5745	110.29	101.1			34.64	8.66	34.11	102	247	Average
5745	116.9	107.71			34.64	8.66	34.11	102	247	Peak
5850	47.27	37.97	90.29	-43.02	34.74	8.7	34.14	102	247	Average
5850	62.22	52.92	96.9	-34.68	34.74	8.7	34.14	102	247	Peak

REMARKS:

- Emission Level = Read Level + Antenna Factor + Cable Loss - Preamp Factor  
Margin value = Emission level – Limit value
- 5745MHz: Fundamental frequency.
- 5725MHz & 5850MHz: Out of restricted band



A D T

EUT TEST CONDITION		MEASUREMENT DETAIL	
CHANNEL	Channel 157	FREQUENCY RANGE	1GHz ~ 40GHz
INPUT POWER	120Vac, 60 Hz	DETECTOR FUNCTION	Peak (PK) Average (AV)
ENVIRONMENTAL CONDITIONS	25deg. C, 65%RH	TESTED BY	Kay Wu

**ANTENNA POLARITY & TEST DISTANCE: HORIZONTAL AT 3 M**

FREQ. (MHz)	EMISSION LEVEL (dBuV/m)	READ LEVEL (dBuV)	LIMIT (dBuV/m)	MARGIN (dB)	ANTENNA FACTOR (dB/m)	CABLE LOSS (dB)	PREAMP FACTOR (dB)	ANTENNA HEIGHT (cm)	TABLE ANGLE (Degree)	REMARK
5725	45.15	35.99	83.05	-37.9	34.62	8.65	34.11	112	194	Average
5725	63.33	54.17	90.79	-27.46	34.62	8.65	34.11	112	194	Peak
5785	103.05	93.82			34.68	8.68	34.13	112	194	Average
5785	110.79	101.56			34.68	8.68	34.13	112	194	Peak
5850	44.75	35.45	83.05	-38.3	34.74	8.7	34.14	112	194	Average
5850	63.26	53.96	90.79	-27.53	34.74	8.7	34.14	112	194	Peak

**ANTENNA POLARITY & TEST DISTANCE: VERTICAL AT 3 M**

FREQ. (MHz)	EMISSION LEVEL (dBuV/m)	READ LEVEL (dBuV)	LIMIT (dBuV/m)	MARGIN (dB)	ANTENNA FACTOR (dB/m)	CABLE LOSS (dB)	PREAMP FACTOR (dB)	ANTENNA HEIGHT (cm)	TABLE ANGLE (Degree)	REMARK
5725	48.41	39.25	90.27	-41.86	34.62	8.65	34.11	100	247	Average
5725	63.13	53.97	96.61	-33.48	34.62	8.65	34.11	100	247	Peak
5785	110.27	101.04			34.68	8.68	34.13	100	247	Average
5785	116.61	107.38			34.68	8.68	34.13	100	247	Peak
5850	48.64	39.34	90.27	-41.63	34.74	8.7	34.14	100	247	Average
5850	63.27	53.97	96.61	-33.34	34.74	8.7	34.14	100	247	Peak

**REMARKS:**

- Emission Level = Read Level + Antenna Factor + Cable Loss - Preamp Factor  
Margin value = Emission level – Limit value
- 5785MHz: Fundamental frequency.
- 5725MHz & 5850MHz: Out of restricted band





A D T

EUT TEST CONDITION		MEASUREMENT DETAIL	
CHANNEL	Channel 165	FREQUENCY RANGE	1GHz ~ 40GHz
INPUT POWER	120Vac, 60 Hz	DETECTOR FUNCTION	Peak (PK) Average (AV)
ENVIRONMENTAL CONDITIONS	25deg. C, 65%RH	TESTED BY	Kay Wu

**ANTENNA POLARITY & TEST DISTANCE: HORIZONTAL AT 3 M**

FREQ. (MHz)	EMISSION LEVEL (dBuV/m)	READ LEVEL (dBuV)	LIMIT (dBuV/m)	MARGIN (dB)	ANTENNA FACTOR (dB/m)	CABLE LOSS (dB)	PREAMP FACTOR (dB)	ANTENNA HEIGHT (cm)	TABLE ANGLE (Degree)	REMARK
5725	44.83	35.67	82.69	-37.86	34.62	8.65	34.11	111	189	Average
5725	62.69	53.53	89.82	-27.13	34.62	8.65	34.11	111	189	Peak
5825	102.69	93.4			34.73	8.69	34.13	111	189	Average
5825	109.82	100.53			34.73	8.69	34.13	111	189	Peak
5850	48.58	39.28	82.69	-34.11	34.74	8.7	34.14	111	189	Average
5850	63.46	54.16	89.82	-26.36	34.74	8.7	34.14	111	189	Peak

**ANTENNA POLARITY & TEST DISTANCE: VERTICAL AT 3 M**

FREQ. (MHz)	EMISSION LEVEL (dBuV/m)	READ LEVEL (dBuV)	LIMIT (dBuV/m)	MARGIN (dB)	ANTENNA FACTOR (dB/m)	CABLE LOSS (dB)	PREAMP FACTOR (dB)	ANTENNA HEIGHT (cm)	TABLE ANGLE (Degree)	REMARK
5725	48.12	38.96	90.26	-42.14	34.62	8.65	34.11	100	248	Average
5725	63.3	54.14	97.24	-33.94	34.62	8.65	34.11	100	248	Peak
5825	110.26	100.97			34.73	8.69	34.13	100	248	Average
5825	117.24	107.95			34.73	8.69	34.13	100	248	Peak
5850	54.82	45.52	90.26	-35.44	34.74	8.7	34.14	100	248	Average
5850	65.43	56.13	97.24	-31.81	34.74	8.7	34.14	100	248	Peak

**REMARKS:**

- Emission Level = Read Level + Antenna Factor + Cable Loss - Preamp Factor  
Margin value = Emission level – Limit value
- 5825MHz: Fundamental frequency.
- 5725MHz & 5850MHz: Out of restricted band



A D T

**802.11n (20MHz)**

EUT TEST CONDITION		MEASUREMENT DETAIL	
CHANNEL	Channel 149	FREQUENCY RANGE	1GHz ~ 40GHz
INPUT POWER	120Vac, 60 Hz	DETECTOR FUNCTION	Peak (PK) Average (AV)
ENVIRONMENTAL CONDITIONS	25deg. C, 65%RH	TESTED BY	Kay Wu

ANTENNA POLARITY & TEST DISTANCE: HORIZONTAL AT 3 M										
FREQ. (MHz)	EMISSION LEVEL (dBuV/m)	READ LEVEL (dBuV)	LIMIT (dBuV/m)	MARGIN (dB)	ANTENNA FACTOR (dB/m)	CABLE LOSS (dB)	PREAMP FACTOR (dB)	ANTENNA HEIGHT (cm)	TABLE ANGLE (Degree)	REMARK
5725	54.25	45.09	83.12	-28.87	34.62	8.65	34.11	112	194	Average
5725	64.73	55.57	91.03	-26.3	34.62	8.65	34.11	112	194	Peak
5745	103.12	93.93			34.64	8.66	34.11	112	194	Average
5745	111.03	101.84			34.64	8.66	34.11	112	194	Peak
5850	44.78	35.48	83.12	-38.34	34.74	8.7	34.14	112	194	Average
5850	64	54.7	91.03	-27.03	34.74	8.7	34.14	112	194	Peak
ANTENNA POLARITY & TEST DISTANCE: VERTICAL AT 3 M										
FREQ. (MHz)	EMISSION LEVEL (dBuV/m)	READ LEVEL (dBuV)	LIMIT (dBuV/m)	MARGIN (dB)	ANTENNA FACTOR (dB/m)	CABLE LOSS (dB)	PREAMP FACTOR (dB)	ANTENNA HEIGHT (cm)	TABLE ANGLE (Degree)	REMARK
5725	62.46	53.3	89.86	-27.4	34.62	8.65	34.11	102	247	Average
5725	78.29	69.13	96.53	-18.24	34.62	8.65	34.11	102	247	Peak
5745	109.86	100.67			34.64	8.66	34.11	102	247	Average
5745	116.53	107.34			34.64	8.66	34.11	102	247	Peak
5850	46.67	37.37	89.86	-43.19	34.74	8.7	34.14	102	247	Average
5850	62.45	53.15	96.53	-34.08	34.74	8.7	34.14	102	247	Peak

**REMARKS:**

1. Emission Level = Read Level + Antenna Factor + Cable Loss - Preamp Factor  
Margin value = Emission level – Limit value
2. 5745MHz: Fundamental frequency.
3. 5725MHz & 5850MHz: Out of restricted band



A D T

EUT TEST CONDITION		MEASUREMENT DETAIL	
CHANNEL	Channel 157	FREQUENCY RANGE	1GHz ~ 40GHz
INPUT POWER	120Vac, 60 Hz	DETECTOR FUNCTION	Peak (PK) Average (AV)
ENVIRONMENTAL CONDITIONS	25deg. C, 65%RH	TESTED BY	Kay Wu

**ANTENNA POLARITY & TEST DISTANCE: HORIZONTAL AT 3 M**

FREQ. (MHz)	EMISSION LEVEL (dBuV/m)	READ LEVEL (dBuV)	LIMIT (dBuV/m)	MARGIN (dB)	ANTENNA FACTOR (dB/m)	CABLE LOSS (dB)	PREAMP FACTOR (dB)	ANTENNA HEIGHT (cm)	TABLE ANGLE (Degree)	REMARK
5725	45.2	36.04	82.45	-37.25	34.62	8.65	34.11	113	194	Average
5725	62.66	53.5	90.08	-27.42	34.62	8.65	34.11	113	194	Peak
5785	102.45	93.22			34.68	8.68	34.13	113	194	Average
5785	110.08	100.85			34.68	8.68	34.13	113	194	Peak
5850	44.81	35.51	82.45	-37.64	34.74	8.7	34.14	113	194	Average
5850	63.08	53.78	90.08	-27	34.74	8.7	34.14	113	194	Peak

**ANTENNA POLARITY & TEST DISTANCE: VERTICAL AT 3 M**

FREQ. (MHz)	EMISSION LEVEL (dBuV/m)	READ LEVEL (dBuV)	LIMIT (dBuV/m)	MARGIN (dB)	ANTENNA FACTOR (dB/m)	CABLE LOSS (dB)	PREAMP FACTOR (dB)	ANTENNA HEIGHT (cm)	TABLE ANGLE (Degree)	REMARK
5725	48.34	39.18	89.94	-41.6	34.62	8.65	34.11	100	247	Average
5725	63.34	54.18	96.97	-33.63	34.62	8.65	34.11	100	247	Peak
5785	109.94	100.71			34.68	8.68	34.13	100	247	Average
5785	116.97	107.74			34.68	8.68	34.13	100	247	Peak
5850	48.42	39.12	89.94	-41.52	34.74	8.7	34.14	100	247	Average
5850	63.91	54.61	96.97	-33.06	34.74	8.7	34.14	100	247	Peak

**REMARKS:**

- Emission Level = Read Level + Antenna Factor + Cable Loss - Preamp Factor  
Margin value = Emission level – Limit value
- 5785MHz: Fundamental frequency.
- 5725MHz & 5850MHz: Out of restricted band



A D T

EUT TEST CONDITION		MEASUREMENT DETAIL	
CHANNEL	Channel 165	FREQUENCY RANGE	1GHz ~ 40GHz
INPUT POWER	120Vac, 60 Hz	DETECTOR FUNCTION	Peak (PK) Average (AV)
ENVIRONMENTAL CONDITIONS	25deg. C, 65%RH	TESTED BY	Kay Wu

**ANTENNA POLARITY & TEST DISTANCE: HORIZONTAL AT 3 M**

FREQ. (MHz)	EMISSION LEVEL (dBuV/m)	READ LEVEL (dBuV)	LIMIT (dBuV/m)	MARGIN (dB)	ANTENNA FACTOR (dB/m)	CABLE LOSS (dB)	PREAMP FACTOR (dB)	ANTENNA HEIGHT (cm)	TABLE ANGLE (Degree)	REMARK
5725	44.56	35.4	82.78	-38.22	34.62	8.65	34.11	103	188	Average
5725	63.21	54.05	90.06	-26.85	34.62	8.65	34.11	103	188	Peak
5825	102.78	93.49			34.73	8.69	34.13	103	188	Average
5825	110.06	100.77			34.73	8.69	34.13	103	188	Peak
5850	49.33	40.03	82.78	-33.45	34.74	8.7	34.14	103	188	Average
5850	64.09	54.79	90.06	-25.97	34.74	8.7	34.14	103	188	Peak

**ANTENNA POLARITY & TEST DISTANCE: VERTICAL AT 3 M**

FREQ. (MHz)	EMISSION LEVEL (dBuV/m)	READ LEVEL (dBuV)	LIMIT (dBuV/m)	MARGIN (dB)	ANTENNA FACTOR (dB/m)	CABLE LOSS (dB)	PREAMP FACTOR (dB)	ANTENNA HEIGHT (cm)	TABLE ANGLE (Degree)	REMARK
5725	44.56	35.4	90.4	-45.84	34.62	8.65	34.11	100	247	Average
5725	62.98	53.82	97.14	-34.16	34.62	8.65	34.11	100	247	Peak
5825	110.4	101.11			34.73	8.69	34.13	100	247	Average
5825	117.14	107.85			34.73	8.69	34.13	100	247	Peak
5850	56.54	47.24	90.4	-33.86	34.74	8.7	34.14	100	247	Average
5850	73.11	63.81	97.14	-24.03	34.74	8.7	34.14	100	247	Peak

**REMARKS:**

- Emission Level = Read Level + Antenna Factor + Cable Loss - Preamp Factor  
Margin value = Emission level – Limit value
- 5825MHz: Fundamental frequency.
- 5725MHz & 5850MHz: Out of restricted band



A D T

## 802.11n (40MHz)

EUT TEST CONDITION		MEASUREMENT DETAIL	
CHANNEL	Channel 151	FREQUENCY RANGE	1GHz ~ 40GHz
INPUT POWER	120Vac, 60 Hz	DETECTOR FUNCTION	Peak (PK) Average (AV)
ENVIRONMENTAL CONDITIONS	25deg. C, 65%RH	TESTED BY	Kay Wu

ANTENNA POLARITY & TEST DISTANCE: HORIZONTAL AT 3 M										
FREQ. (MHz)	EMISSION LEVEL (dBuV/m)	READ LEVEL (dBuV)	LIMIT (dBuV/m)	MARGIN (dB)	ANTENNA FACTOR (dB/m)	CABLE LOSS (dB)	PREAMP FACTOR (dB)	ANTENNA HEIGHT (cm)	TABLE ANGLE (Degree)	REMARK
5725	63.8	54.64	81.18	-17.38	34.62	8.65	34.11	112	194	Average
5725	72.94	63.78	88.14	-15.2	34.62	8.65	34.11	112	194	Peak
5755	101.18	91.97			34.66	8.66	34.11	112	194	Average
5755	108.14	98.93			34.66	8.66	34.11	112	194	Peak
5850	47.97	38.67	81.18	-33.21	34.74	8.7	34.14	112	194	Average
5850	57.16	47.86	88.14	-30.98	34.74	8.7	34.14	112	194	Peak
ANTENNA POLARITY & TEST DISTANCE: VERTICAL AT 3 M										
FREQ. (MHz)	EMISSION LEVEL (dBuV/m)	READ LEVEL (dBuV)	LIMIT (dBuV/m)	MARGIN (dB)	ANTENNA FACTOR (dB/m)	CABLE LOSS (dB)	PREAMP FACTOR (dB)	ANTENNA HEIGHT (cm)	TABLE ANGLE (Degree)	REMARK
5725	72.67	63.51	85.84	-13.17	34.62	8.65	34.11	118	171	Average
5725	81.08	71.92	93.4	-12.32	34.62	8.65	34.11	118	171	Peak
5755	105.84	96.63			34.66	8.66	34.11	118	171	Average
5755	113.4	104.19			34.66	8.66	34.11	118	171	Peak
5850	49.02	39.72	85.84	-36.82	34.74	8.7	34.14	118	171	Average
5850	60.01	50.71	93.4	-33.39	34.74	8.7	34.14	118	171	Peak

## REMARKS:

- Emission Level = Read Level + Antenna Factor + Cable Loss - Preamp Factor  
Margin value = Emission level – Limit value
- 5755MHz: Fundamental frequency.
- 5725MHz & 5850MHz: Out of restricted band



A D T

EUT TEST CONDITION		MEASUREMENT DETAIL	
CHANNEL	Channel 159	FREQUENCY RANGE	1GHz ~ 40GHz
INPUT POWER	120Vac, 60 Hz	DETECTOR FUNCTION	Peak (PK) Average (AV)
ENVIRONMENTAL CONDITIONS	25deg. C, 65%RH	TESTED BY	Kay Wu

**ANTENNA POLARITY & TEST DISTANCE: HORIZONTAL AT 3 M**

FREQ. (MHz)	EMISSION LEVEL (dBuV/m)	READ LEVEL (dBuV)	LIMIT (dBuV/m)	MARGIN (dB)	ANTENNA FACTOR (dB/m)	CABLE LOSS (dB)	PREAMP FACTOR (dB)	ANTENNA HEIGHT (cm)	TABLE ANGLE (Degree)	REMARK
5725	48.8	39.64	80.27	-31.47	34.62	8.65	34.11	112	194	Average
5725	58.25	49.09	87.8	-29.55	34.62	8.65	34.11	112	194	Peak
5795	100.27	91.03			34.69	8.68	34.13	112	194	Average
5795	107.8	98.56			34.69	8.68	34.13	112	194	Peak
5850	50.01	40.71	80.27	-30.26	34.74	8.7	34.14	112	194	Average
5850	60.05	50.75	87.8	-27.75	34.74	8.7	34.14	112	194	Peak

**ANTENNA POLARITY & TEST DISTANCE: VERTICAL AT 3 M**

FREQ. (MHz)	EMISSION LEVEL (dBuV/m)	READ LEVEL (dBuV)	LIMIT (dBuV/m)	MARGIN (dB)	ANTENNA FACTOR (dB/m)	CABLE LOSS (dB)	PREAMP FACTOR (dB)	ANTENNA HEIGHT (cm)	TABLE ANGLE (Degree)	REMARK
5725	49.8	40.64	86.23	-36.43	34.62	8.65	34.11	118	170	Average
5725	62.42	53.26	93.87	-31.45	34.62	8.65	34.11	118	170	Peak
5795	106.23	96.99			34.69	8.68	34.13	118	170	Average
5795	113.87	104.63			34.69	8.68	34.13	118	170	Peak
5850	52.34	43.04	86.23	-33.89	34.74	8.7	34.14	118	170	Average
5850	63.64	54.34	93.87	-30.23	34.74	8.7	34.14	118	170	Peak

**REMARKS:**

- Emission Level = Read Level + Antenna Factor + Cable Loss - Preamp Factor  
Margin value = Emission level – Limit value
- 5795MHz: Fundamental frequency.
- 5725MHz & 5850MHz: Out of restricted band



A D T

**802.11ac (80MHz)**

EUT TEST CONDITION		MEASUREMENT DETAIL	
CHANNEL	Channel 155	FREQUENCY RANGE	1GHz ~ 40GHz
INPUT POWER	120Vac, 60 Hz	DETECTOR FUNCTION	Peak (PK) Average (AV)
ENVIRONMENTAL CONDITIONS	25deg. C, 65%RH	TESTED BY	Kay Wu

**ANTENNA POLARITY & TEST DISTANCE: HORIZONTAL AT 3 M**

FREQ. (MHz)	EMISSION LEVEL (dBuV/m)	READ LEVEL (dBuV)	LIMIT (dBuV/m)	MARGIN (dB)	ANTENNA FACTOR (dB/m)	CABLE LOSS (dB)	PREAMP FACTOR (dB)	ANTENNA HEIGHT (cm)	TABLE ANGLE (Degree)	REMARK
5725	69.78	60.62	78.32	-8.54	34.62	8.65	34.11	113	193	Average
5725	79.57	70.41	87.95	-8.38	34.62	8.65	34.11	113	193	Peak
5775	98.32	89.09			34.68	8.67	34.12	113	193	Average
5775	107.95	98.72			34.68	8.67	34.12	113	193	Peak
5850	54.46	45.16	78.32	-23.86	34.74	8.7	34.14	113	193	Average
5850	65.64	56.34	87.95	-22.31	34.74	8.7	34.14	113	193	Peak

**ANTENNA POLARITY & TEST DISTANCE: VERTICAL AT 3 M**

FREQ. (MHz)	EMISSION LEVEL (dBuV/m)	READ LEVEL (dBuV)	LIMIT (dBuV/m)	MARGIN (dB)	ANTENNA FACTOR (dB/m)	CABLE LOSS (dB)	PREAMP FACTOR (dB)	ANTENNA HEIGHT (cm)	TABLE ANGLE (Degree)	REMARK
5725	73.93	64.77	84.15	-10.22	34.62	8.65	34.11	100	246	Average
5725	82.12	72.96	92.95	-10.83	34.62	8.65	34.11	100	246	Peak
5775	104.15	94.92			34.68	8.67	34.12	100	246	Average
5775	112.95	103.72			34.68	8.67	34.12	100	246	Peak
5850	61.68	52.38	84.15	-22.47	34.74	8.7	34.14	100	246	Average
5850	69.77	60.47	92.95	-23.18	34.74	8.7	34.14	100	246	Peak

**REMARKS:**

- Emission Level = Read Level + Antenna Factor + Cable Loss - Preamp Factor  
Margin value = Emission level – Limit value
- 5825MHz: Fundamental frequency.
- 5725MHz & 5850MHz: Out of restricted band



A D T

**MODE A (2TX)**

**802.11n (20MHz)**

EUT TEST CONDITION		MEASUREMENT DETAIL	
CHANNEL	Channel 149	FREQUENCY RANGE	1GHz ~ 40GHz
INPUT POWER	120Vac, 60 Hz	DETECTOR FUNCTION	Peak (PK) Average (AV)
ENVIRONMENTAL CONDITIONS	25deg. C, 65%RH	TESTED BY	Kay Wu

ANTENNA POLARITY & TEST DISTANCE: HORIZONTAL AT 3 M										
FREQ. (MHz)	EMISSION LEVEL (dBuV/m)	READ LEVEL (dBuV)	LIMIT (dBuV/m)	MARGIN (dB)	ANTENNA FACTOR (dB/m)	CABLE LOSS (dB)	PREAMP FACTOR (dB)	ANTENNA HEIGHT (cm)	TABLE ANGLE (Degree)	REMARK
5725	54.95	45.79	85.82	-30.87	34.62	8.65	34.11	138	213	Average
5725	76.79	67.63	93.69	-16.9	34.62	8.65	34.11	138	213	Peak
5745	105.82	96.63			34.64	8.66	34.11	152	140	Average
5745	113.69	104.5			34.64	8.66	34.11	152	140	Peak
5850	45.56	36.26	85.82	-40.26	34.74	8.7	34.14	152	140	Average
5850	61.93	52.63	93.69	-31.76	34.74	8.7	34.14	152	140	Peak
ANTENNA POLARITY & TEST DISTANCE: VERTICAL AT 3 M										
FREQ. (MHz)	EMISSION LEVEL (dBuV/m)	READ LEVEL (dBuV)	LIMIT (dBuV/m)	MARGIN (dB)	ANTENNA FACTOR (dB/m)	CABLE LOSS (dB)	PREAMP FACTOR (dB)	ANTENNA HEIGHT (cm)	TABLE ANGLE (Degree)	REMARK
5725	55.84	46.68	87.58	-31.74	34.62	8.65	34.11	100	229	Average
5725	76.38	67.22	94.52	-18.14	34.62	8.65	34.11	100	229	Peak
5745	107.58	98.39			34.64	8.66	34.11	110	228	Average
5745	114.52	105.33			34.64	8.66	34.11	110	228	Peak
5850	47.37	38.07	87.58	-40.21	34.74	8.7	34.14	110	228	Average
5850	63.52	54.22	94.52	-31	34.74	8.7	34.14	110	228	Peak

**RE REMARKS:**

- Emission Level = Read Level + Antenna Factor + Cable Loss - Preamp Factor  
Margin value = Emission level – Limit value
- 5825MHz: Fundamental frequency.
- 5725MHz & 5850MHz: Out of restricted band





A D T

EUT TEST CONDITION		MEASUREMENT DETAIL	
CHANNEL	Channel 157	FREQUENCY RANGE	1GHz ~ 40GHz
INPUT POWER	120Vac, 60 Hz	DETECTOR FUNCTION	Peak (PK) Average (AV)
ENVIRONMENTAL CONDITIONS	25deg. C, 65%RH	TESTED BY	Kay Wu

**ANTENNA POLARITY & TEST DISTANCE: HORIZONTAL AT 3 M**

FREQ. (MHz)	EMISSION LEVEL (dBuV/m)	READ LEVEL (dBuV)	LIMIT (dBuV/m)	MARGIN (dB)	ANTENNA FACTOR (dB/m)	CABLE LOSS (dB)	PREAMP FACTOR (dB)	ANTENNA HEIGHT (cm)	TABLE ANGLE (Degree)	REMARK
5725	48	38.84	87.99	-39.99	34.62	8.65	34.11	123	183	Average
5725	62.83	53.67	95.2	-32.37	34.62	8.65	34.11	123	183	Peak
5785	107.99	98.76			34.68	8.68	34.13	123	183	Average
5785	115.2	105.97			34.68	8.68	34.13	123	183	Peak
5850	47.92	38.62	87.99	-40.07	34.74	8.7	34.14	123	183	Average
5850	63.11	53.81	95.2	-32.09	34.74	8.7	34.14	123	183	Peak

**ANTENNA POLARITY & TEST DISTANCE: VERTICAL AT 3 M**

FREQ. (MHz)	EMISSION LEVEL (dBuV/m)	READ LEVEL (dBuV)	LIMIT (dBuV/m)	MARGIN (dB)	ANTENNA FACTOR (dB/m)	CABLE LOSS (dB)	PREAMP FACTOR (dB)	ANTENNA HEIGHT (cm)	TABLE ANGLE (Degree)	REMARK
5725	47.4	38.24	85.98	-38.58	34.62	8.65	34.11	100	247	Average
5725	62.22	53.06	93.35	-31.13	34.62	8.65	34.11	100	247	Peak
5785	105.98	96.75			34.68	8.68	34.13	100	247	Average
5785	113.35	104.12			34.68	8.68	34.13	100	247	Peak
5850	47.47	38.17	85.98	-38.51	34.74	8.7	34.14	100	247	Average
5850	62.58	53.28	93.35	-30.77	34.74	8.7	34.14	100	247	Peak

**REMARKS:**

7. Emission Level = Read Level + Antenna Factor + Cable Loss - Preamp Factor  
Margin value = Emission level – Limit value
8. 5825MHz: Fundamental frequency.
9. 5725MHz & 5850MHz: Out of restricted band



A D T

EUT TEST CONDITION		MEASUREMENT DETAIL	
CHANNEL	Channel 165	FREQUENCY RANGE	1GHz ~ 40GHz
INPUT POWER	120Vac, 60 Hz	DETECTOR FUNCTION	Peak (PK) Average (AV)
ENVIRONMENTAL CONDITIONS	25deg. C, 65%RH	TESTED BY	Kay Wu

**ANTENNA POLARITY & TEST DISTANCE: HORIZONTAL AT 3 M**

FREQ. (MHz)	EMISSION LEVEL (dBuV/m)	READ LEVEL (dBuV)	LIMIT (dBuV/m)	MARGIN (dB)	ANTENNA FACTOR (dB/m)	CABLE LOSS (dB)	PREAMP FACTOR (dB)	ANTENNA HEIGHT (cm)	TABLE ANGLE (Degree)	REMARK
5725	45.93	36.77	86.14	-40.21	34.62	8.65	34.11	160	142	Average
5725	62.83	53.67	93.92	-31.09	34.62	8.65	34.11	160	142	Peak
5825	106.14	96.85			34.73	8.69	34.13	160	142	Average
5825	113.92	104.63			34.73	8.69	34.13	160	142	Peak
5850	50.78	41.48	86.14	-35.36	34.74	8.7	34.14	135	180	Average
5850	72.64	63.34	93.92	-21.28	34.74	8.7	34.14	135	180	Peak

**ANTENNA POLARITY & TEST DISTANCE: VERTICAL AT 3 M**

FREQ. (MHz)	EMISSION LEVEL (dBuV/m)	READ LEVEL (dBuV)	LIMIT (dBuV/m)	MARGIN (dB)	ANTENNA FACTOR (dB/m)	CABLE LOSS (dB)	PREAMP FACTOR (dB)	ANTENNA HEIGHT (cm)	TABLE ANGLE (Degree)	REMARK
5725	47.11	37.95	86.38	-39.27	34.62	8.65	34.11	100	247	Average
5725	62.34	53.18	94.27	-31.93	34.62	8.65	34.11	100	247	Peak
5825	106.38	97.09			34.73	8.69	34.13	100	247	Average
5825	114.27	104.98			34.73	8.69	34.13	100	247	Peak
5850	49.98	40.68	86.38	-36.4	34.74	8.7	34.14	100	247	Average
5850	70.27	60.97	94.27	-24	34.74	8.7	34.14	100	247	Peak

**REMARKS:**

10. Emission Level = Read Level + Antenna Factor + Cable Loss - Preamp Factor  
Margin value = Emission level – Limit value
11. 5825MHz: Fundamental frequency.
12. 5725MHz & 5850MHz: Out of restricted band



A D T

**802.11n (40MHz)**

EUT TEST CONDITION		MEASUREMENT DETAIL	
CHANNEL	Channel 151	FREQUENCY RANGE	1GHz ~ 40GHz
INPUT POWER	120Vac, 60 Hz	DETECTOR FUNCTION	Peak (PK) Average (AV)
ENVIRONMENTAL CONDITIONS	25deg. C, 65%RH	TESTED BY	Kay Wu

**ANTENNA POLARITY & TEST DISTANCE: HORIZONTAL AT 3 M**

FREQ. (MHz)	EMISSION LEVEL (dBuV/m)	READ LEVEL (dBuV)	LIMIT (dBuV/m)	MARGIN (dB)	ANTENNA FACTOR (dB/m)	CABLE LOSS (dB)	PREAMP FACTOR (dB)	ANTENNA HEIGHT (cm)	TABLE ANGLE (Degree)	REMARK
5725	68.96	59.8	84.89	-15.93	34.62	8.65	34.11	127	194	Average
5725	80.65	71.49	90.17	-9.52	34.62	8.65	34.11	127	194	Peak
5755	104.89	95.68			34.66	8.66	34.11	151	148	Average
5755	110.17	100.96			34.66	8.66	34.11	151	148	Peak
5850	47.97	38.67	84.89	-36.92	34.74	8.7	34.14	151	148	Average
5850	57.27	47.97	90.17	-32.9	34.74	8.7	34.14	151	148	Peak

**ANTENNA POLARITY & TEST DISTANCE: VERTICAL AT 3 M**

FREQ. (MHz)	EMISSION LEVEL (dBuV/m)	READ LEVEL (dBuV)	LIMIT (dBuV/m)	MARGIN (dB)	ANTENNA FACTOR (dB/m)	CABLE LOSS (dB)	PREAMP FACTOR (dB)	ANTENNA HEIGHT (cm)	TABLE ANGLE (Degree)	REMARK
5725	69.84	60.68	84.91	-15.07	34.62	8.65	34.11	122	157	Average
5725	83.01	73.85	91.23	-8.22	34.62	8.65	34.11	122	157	Peak
5755	104.91	95.7			34.66	8.66	34.11	110	228	Average
5755	111.23	102.02			34.66	8.66	34.11	110	228	Peak
5850	49	39.7	84.91	-35.91	34.74	8.7	34.14	110	228	Average
5850	57.32	48.02	91.23	-33.91	34.74	8.7	34.14	110	228	Peak

**REMARKS:**

- Emission Level = Read Level + Antenna Factor + Cable Loss - Preamp Factor  
Margin value = Emission level – Limit value
- 5755MHz: Fundamental frequency.
- 5725MHz & 5850MHz: Out of restricted band



A D T

EUT TEST CONDITION		MEASUREMENT DETAIL	
CHANNEL	Channel 159	FREQUENCY RANGE	1GHz ~ 40GHz
INPUT POWER	120Vac, 60 Hz	DETECTOR FUNCTION	Peak (PK) Average (AV)
ENVIRONMENTAL CONDITIONS	25deg. C, 65%RH	TESTED BY	Kay Wu

**ANTENNA POLARITY & TEST DISTANCE: HORIZONTAL AT 3 M**

FREQ. (MHz)	EMISSION LEVEL (dBuV/m)	READ LEVEL (dBuV)	LIMIT (dBuV/m)	MARGIN (dB)	ANTENNA FACTOR (dB/m)	CABLE LOSS (dB)	PREAMP FACTOR (dB)	ANTENNA HEIGHT (cm)	TABLE ANGLE (Degree)	REMARK
5725	47.94	38.78	83.39	-35.45	34.62	8.65	34.11	152	140	Average
5725	57.99	48.83	90.8	-32.81	34.62	8.65	34.11	152	140	Peak
5795	103.39	94.15			34.69	8.68	34.13	152	140	Average
5795	110.8	101.56			34.69	8.68	34.13	152	140	Peak
5850	48.9	39.6	83.39	-34.49	34.74	8.7	34.14	152	140	Average
5850	58.88	49.58	90.8	-31.92	34.74	8.7	34.14	152	140	Peak

**ANTENNA POLARITY & TEST DISTANCE: VERTICAL AT 3 M**

FREQ. (MHz)	EMISSION LEVEL (dBuV/m)	READ LEVEL (dBuV)	LIMIT (dBuV/m)	MARGIN (dB)	ANTENNA FACTOR (dB/m)	CABLE LOSS (dB)	PREAMP FACTOR (dB)	ANTENNA HEIGHT (cm)	TABLE ANGLE (Degree)	REMARK
5725	47.84	38.68	84.94	-37.1	34.62	8.65	34.11	110	170	Average
5725	56.98	47.82	91.85	-34.87	34.62	8.65	34.11	110	170	Peak
5795	104.94	95.7			34.69	8.68	34.13	110	170	Average
5795	111.85	102.61			34.69	8.68	34.13	110	170	Peak
5850	48.71	39.41	84.94	-36.23	34.74	8.7	34.14	110	170	Average
5850	57.27	47.97	91.85	-34.58	34.74	8.7	34.14	110	170	Peak

**REMARKS:**

- Emission Level = Read Level + Antenna Factor + Cable Loss - Preamp Factor  
Margin value = Emission level – Limit value
- 5795MHz: Fundamental frequency.
- 5725MHz & 5850MHz: Out of restricted band



A D T

802.11ac (80MHz)

EUT TEST CONDITION		MEASUREMENT DETAIL	
CHANNEL	Channel 155	FREQUENCY RANGE	1GHz ~ 40GHz
INPUT POWER	120Vac, 60 Hz	DETECTOR FUNCTION	Peak (PK) Average (AV)
ENVIRONMENTAL CONDITIONS	25deg. C, 65%RH	TESTED BY	Kay Wu

ANTENNA POLARITY & TEST DISTANCE: HORIZONTAL AT 3 M

FREQ. (MHz)	EMISSION LEVEL (dBuV/m)	READ LEVEL (dBuV)	LIMIT (dBuV/m)	MARGIN (dB)	ANTENNA FACTOR (dB/m)	CABLE LOSS (dB)	PREAMP FACTOR (dB)	ANTENNA HEIGHT (cm)	TABLE ANGLE (Degree)	REMARK
5725	74.14	64.98	83.47	-9.33	34.62	8.65	34.11	138	142	Average
5725	86.22	77.06	91.94	-5.72	34.62	8.65	34.11	138	142	Peak
5775	103.47	94.24			34.68	8.67	34.12	138	198	Average
5775	111.94	102.71			34.68	8.67	34.12	138	198	Peak
5850	55.81	46.51	83.47	-27.66	34.74	8.7	34.14	138	198	Average
5850	65.23	55.93	91.94	-26.71	34.74	8.7	34.14	138	198	Peak

ANTENNA POLARITY & TEST DISTANCE: VERTICAL AT 3 M

FREQ. (MHz)	EMISSION LEVEL (dBuV/m)	READ LEVEL (dBuV)	LIMIT (dBuV/m)	MARGIN (dB)	ANTENNA FACTOR (dB/m)	CABLE LOSS (dB)	PREAMP FACTOR (dB)	ANTENNA HEIGHT (cm)	TABLE ANGLE (Degree)	REMARK
5725	74.26	65.1	83.82	-9.56	34.62	8.65	34.11	100	213	Average
5725	84.6	75.44	93.89	-9.29	34.62	8.65	34.11	100	213	Peak
5775	103.82	94.59			34.68	8.67	34.12	133	190	Average
5775	113.89	104.66			34.68	8.67	34.12	133	190	Peak
5850	56.25	46.95	83.82	-27.57	34.74	8.7	34.14	133	190	Average
5850	65.57	56.27	93.89	-28.32	34.74	8.7	34.14	133	190	Peak

REMARKS:

- Emission Level = Read Level + Antenna Factor + Cable Loss - Preamp Factor  
Margin value = Emission level – Limit value
- 5775MHz: Fundamental frequency.
- 5725MHz & 5850MHz: Out of restricted band



A D T

**MODE A**

**BELOW 1GHz WORST-CASE DATA :**

**802.11ac (80MHz)**

EUT TEST CONDITION		MEASUREMENT DETAIL	
CHANNEL	Channel 155	FREQUENCY RANGE	30MHz ~ 1GHz
INPUT POWER	120Vac, 60 Hz	DETECTOR FUNCTION	Peak (PK)
ENVIRONMENTAL CONDITIONS	25deg. C, 65%RH	TESTED BY	Kay Wu

**ANTENNA POLARITY & TEST DISTANCE: HORIZONTAL AT 3 M**

FREQ. (MHz)	EMISSION LEVEL (dBuV/m)	READ LEVEL (dBuV)	LIMIT (dBuV/m)	MARGIN (dB)	ANTENNA FACTOR (dB/m)	CABLE LOSS (dB)	PREAMP FACTOR (dB)	ANTENNA HEIGHT (cm)	TABLE ANGLE (Degree)	REMARK
96.96	32	53.36	43.5	-11.5	9.46	1.28	32.1	119	37	Peak
166.35	34.17	54.61	43.5	-9.33	10.29	1.52	32.25	134	75	Peak
284.07	33.55	49.87	46	-12.45	13.77	2.03	32.12	235	124	Peak
374.9	38.12	51.71	46	-7.88	16.3	2.26	32.15	107	88	Peak
599.6	36.98	45.2	46	-9.02	21.1	2.87	32.19	189	47	Peak
875.4	29.35	32.69	46	-16.65	24.8	3.49	31.63	132	116	Peak

**ANTENNA POLARITY & TEST DISTANCE: VERTICAL AT 3 M**

FREQ. (MHz)	EMISSION LEVEL (dBuV/m)	READ LEVEL (dBuV)	LIMIT (dBuV/m)	MARGIN (dB)	ANTENNA FACTOR (dB/m)	CABLE LOSS (dB)	PREAMP FACTOR (dB)	ANTENNA HEIGHT (cm)	TABLE ANGLE (Degree)	REMARK
43.77	28.07	49.54	40	-11.93	9.85	0.9	32.22	207	61	Peak
95.07	31.29	52.7	43.5	-12.21	9.3	1.28	31.99	137	96	Peak
169.32	34.83	55.48	43.5	-8.67	10.07	1.52	32.24	164	187	Peak
374.9	31.76	45.35	46	-14.24	16.3	2.26	32.15	144	36	Peak
599.6	34.99	43.21	46	-11.01	21.1	2.87	32.19	109	167	Peak
899.2	35.07	38.07	46	-10.93	25	3.49	31.49	227	312	Peak

**REMARKS:** Emission Level = Read Level + Antenna Factor + Cable Loss - Preamp Factor

Margin value = Emission level – Limit value



A D T

**MODE B**

EUT TEST CONDITION		MEASUREMENT DETAIL	
CHANNEL	Channel 155	FREQUENCY RANGE	30MHz ~ 1GHz
INPUT POWER	120Vac, 60 Hz	DETECTOR FUNCTION	Peak (PK) Quasi-peak (QP)
ENVIRONMENTAL CONDITIONS	25deg. C, 65%RH	TESTED BY	Kay Wu

ANTENNA POLARITY & TEST DISTANCE: HORIZONTAL AT 3 M										
FREQ. (MHz)	EMISSION LEVEL (dBuV/m)	READ LEVEL (dBuV)	LIMIT (dBuV/m)	MARGIN (dB)	ANTENNA FACTOR (dB/m)	CABLE LOSS (dB)	PREAMP FACTOR (dB)	ANTENNA HEIGHT (cm)	TABLE ANGLE (Degree)	REMARK
69.96	34.25	57.26	40	-5.75	8.1	1.11	32.22	123	74	QP
92.64	38.69	60.32	43.5	-4.81	9.14	1.11	31.88	187	94	QP
160.68	38.92	58.94	43.5	-4.58	10.73	1.52	32.27	156	145	Peak
374.9	31.45	45.04	46	-14.55	16.3	2.26	32.15	189	149	Peak
499.5	30.56	41.03	46	-15.44	19	2.63	32.1	212	135	Peak
599.6	33.17	41.39	46	-12.83	21.1	2.87	32.19	115	55	Peak
ANTENNA POLARITY & TEST DISTANCE: VERTICAL AT 3 M										
FREQ. (MHz)	EMISSION LEVEL (dBuV/m)	READ LEVEL (dBuV)	LIMIT (dBuV/m)	MARGIN (dB)	ANTENNA FACTOR (dB/m)	CABLE LOSS (dB)	PREAMP FACTOR (dB)	ANTENNA HEIGHT (cm)	TABLE ANGLE (Degree)	REMARK
72.39	39.62	62.56	40	-0.38	8.17	1.11	32.22	181	65	QP
98.58	42.92	64.27	43.5	-0.58	9.58	1.28	32.21	135	74	QP
161.49	38.08	58.17	43.5	-5.42	10.65	1.52	32.26	110	154	Peak
321.7	34.15	49.12	46	-11.85	15.03	2.11	32.11	105	79	Peak
624.8	34.17	41.31	46	-11.83	22.1	2.93	32.17	208	165	Peak
875.4	35.93	39.27	46	-10.07	24.8	3.49	31.63	156	73	Peak

**REMARKS:** Emission Level = Read Level + Antenna Factor + Cable Loss - Preamp Factor  
 Margin value = Emission level – Limit value

## 5.2 CONDUCTED EMISSION MEASUREMENT

### 5.2.1 LIMITS OF CONDUCTED EMISSION MEASUREMENT

FREQUENCY OF EMISSION (MHz)	CONDUCTED LIMIT (dB $\mu$ V)	
	Quasi-peak	Average
0.15 ~ 0.5	66 to 56	56 to 46
0.5 ~ 5	56	46
5 ~ 30	60	50

- NOTE:**
1. The lower limit shall apply at the transition frequencies.
  2. The limit decreases in line with the logarithm of the frequency in the range of 0.15 to 0.50MHz.
  3. All emanations from a class A/B digital device or system, including any network of conductors and apparatus connected thereto, shall not exceed the level of field strengths specified above.

### 5.2.2 TEST INSTRUMENTS

Same as section 4.2.2.

### 5.2.3 TEST PROCEDURES

Same as section 4.2.3.

### 5.2.4 DEVIATION FROM TEST STANDARD

No deviation.

### 5.2.5 TEST SETUP

Same as section 4.2.5.

### 5.2.6 EUT OPERATING CONDITIONS

Same as section 4.1.6.



### 5.2.7 TEST RESULTS

#### CONDUCTED WORST-CASE DATA :

#### MODE A

Frequency Range	150kHz ~ 30MHz	Detector Function & Resolution Bandwidth	Quasi-Peak (QP), 9kHz Average (AV), 9kHz
Input Power	120Vac, 60Hz	Environmental Conditions	25°C, 65%RH
POWER SUPPLY	adapter		

Phase Of Power : Line (L)										
No	Frequency (MHz)	Correction Factor (dB)	Reading Value (dBuV)		Emission Level (dBuV)		Limit (dBuV)		Margin (dB)	
			Q.P.	AV.	Q.P.	AV.	Q.P.	AV.	Q.P.	AV.
1	0.17734	0.27	48.08	41.09	48.35	41.36	64.61	54.61	-16.26	-13.25
2	0.32578	0.29	42.55	26.45	42.84	26.74	59.56	49.56	-16.72	-22.82
3	0.46250	0.30	45.75	30.05	46.05	30.35	56.65	46.65	-10.59	-16.29
4	0.92344	0.33	38.07	26.36	38.40	26.69	56.00	46.00	-17.60	-19.31
5	1.38672	0.35	36.18	29.04	36.53	29.39	56.00	46.00	-19.47	-16.61
6	15.01172	0.53	27.76	20.67	28.29	21.20	60.00	50.00	-31.71	-28.80

#### Remarks:

1. Q.P. and AV. are abbreviations of quasi-peak and average individually.
2. The emission levels of other frequencies were very low against the limit.
3. Margin value = Emission level – Limit value
4. Correction factor = Insertion loss + Cable loss
5. Emission Level = Correction Factor + Reading Value

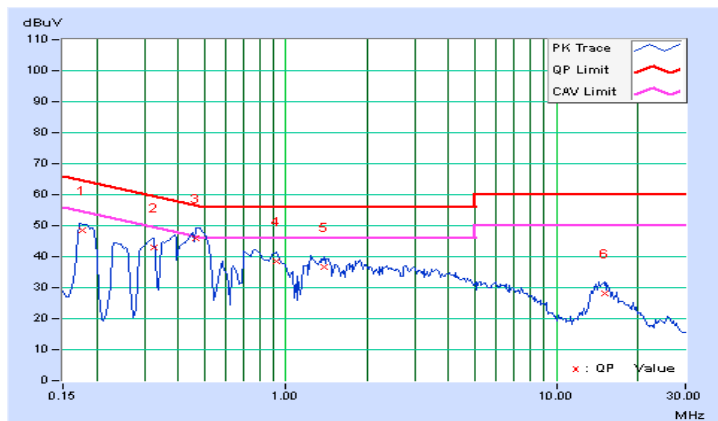



A D T

Frequency Range	150kHz ~ 30MHz	Detector Function & Resolution Bandwidth	Quasi-Peak (QP), 9kHz Average (AV), 9kHz
Input Power	120Vac, 60Hz	Environmental Conditions	25°C, 65%RH
POWER SUPPLY	adapter		

Phase Of Power : Neutral (N)										
No	Frequency (MHz)	Correction Factor (dB)	Reading Value (dBuV)		Emission Level (dBuV)		Limit (dBuV)		Margin (dB)	
			Q.P.	AV.	Q.P.	AV.	Q.P.	AV.	Q.P.	AV.
1	0.18125	0.27	45.98	39.87	46.25	40.14	64.43	54.43	-18.17	-14.28
2	0.46250	0.30	46.60	30.97	46.90	31.27	56.65	46.65	-9.74	-15.37
3	0.75938	0.32	38.95	28.97	39.27	29.29	56.00	46.00	-16.73	-16.71
4	1.39844	0.35	35.74	27.84	36.09	28.19	56.00	46.00	-19.91	-17.81
5	6.07422	0.47	25.41	20.28	25.88	20.75	60.00	50.00	-34.12	-29.25
6	15.01563	0.57	25.79	18.61	26.36	19.18	60.00	50.00	-33.64	-30.82

Remarks:

1. Q.P. and AV. are abbreviations of quasi-peak and average individually.
2. The emission levels of other frequencies were very low against the limit.
3. Margin value = Emission level – Limit value
4. Correction factor = Insertion loss + Cable loss
5. Emission Level = Correction Factor + Reading Value

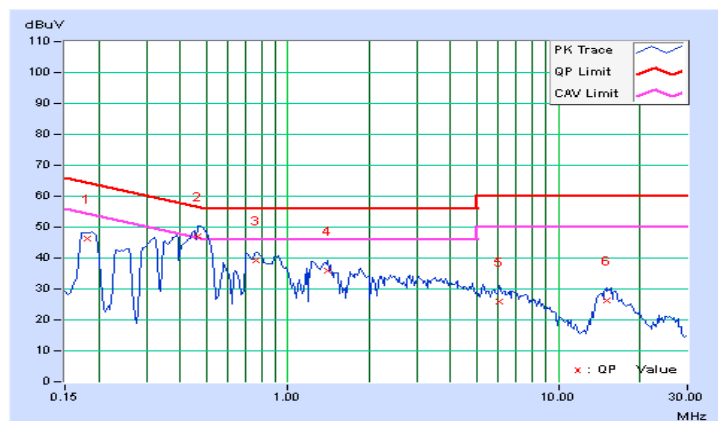



A D T

**MODE B**

Frequency Range	150kHz ~ 30MHz	Detector Function & Resolution Bandwidth	Quasi-Peak (QP), 9kHz Average (AV), 9kHz
Input Power	120Vac, 60Hz	Environmental Conditions	25°C, 65%RH
POWER SUPPLY	POE		

Phase Of Power : Line (L)										
No	Frequency (MHz)	Correction Factor (dB)	Reading Value (dBuV)		Emission Level (dBuV)		Limit (dBuV)		Margin (dB)	
			Q.P.	AV.	Q.P.	AV.	Q.P.	AV.	Q.P.	AV.
1	0.15781	0.27	57.74	42.99	58.01	43.26	65.58	55.58	-7.57	-12.32
2	0.32188	0.29	44.83	34.87	45.12	35.16	59.66	49.66	-14.54	-14.50
3	0.86094	0.33	30.32	22.25	30.65	22.58	56.00	46.00	-25.35	-23.42
4	3.61328	0.42	37.29	29.70	37.71	30.12	56.00	46.00	-18.29	-15.88
5	17.18750	0.56	23.77	19.96	24.33	20.52	60.00	50.00	-35.67	-29.48
6	29.46875	0.45	28.42	24.29	28.87	24.74	60.00	50.00	-31.13	-25.26

Remarks:

1. Q.P. and AV. are abbreviations of quasi-peak and average individually.
2. The emission levels of other frequencies were very low against the limit.
3. Margin value = Emission level – Limit value
4. Correction factor = Insertion loss + Cable loss
5. Emission Level = Correction Factor + Reading Value

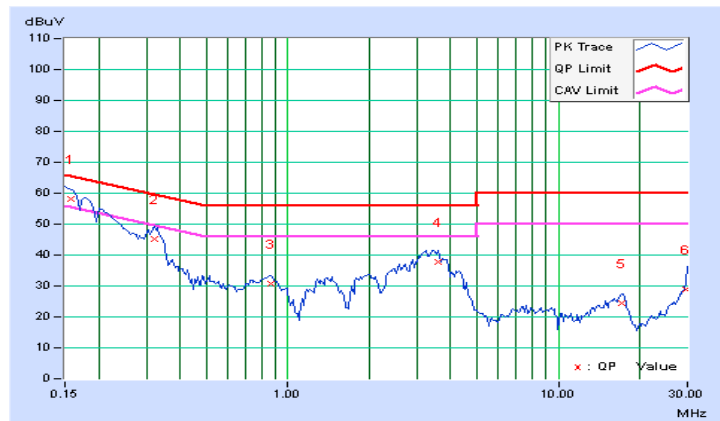



A D T

Frequency Range	150kHz ~ 30MHz	Detector Function & Resolution Bandwidth	Quasi-Peak (QP), 9kHz Average (AV), 9kHz
Input Power	120Vac, 60Hz	Environmental Conditions	25°C, 65%RH
POWER SUPPLY	POE		

Phase Of Power : Neutral (N)										
No	Frequency (MHz)	Correction Factor (dB)	Reading Value (dBuV)		Emission Level (dBuV)		Limit (dBuV)		Margin (dB)	
			Q.P.	AV.	Q.P.	AV.	Q.P.	AV.	Q.P.	AV.
1	0.15781	0.27	57.96	43.00	58.23	43.27	65.58	55.58	-7.35	-12.31
2	0.32188	0.29	43.85	33.10	44.14	33.39	59.66	49.66	-15.52	-16.27
3	0.86094	0.33	29.38	21.27	29.71	21.60	56.00	46.00	-26.29	-24.40
4	3.41797	0.42	38.64	31.80	39.06	32.22	56.00	46.00	-16.94	-13.78
5	17.15234	0.60	20.62	16.77	21.22	17.37	60.00	50.00	-38.78	-32.63
6	29.49219	0.46	26.60	22.61	27.06	23.07	60.00	50.00	-32.94	-26.93

Remarks:

1. Q.P. and AV. are abbreviations of quasi-peak and average individually.
2. The emission levels of other frequencies were very low against the limit.
3. Margin value = Emission level – Limit value
4. Correction factor = Insertion loss + Cable loss
5. Emission Level = Correction Factor + Reading Value

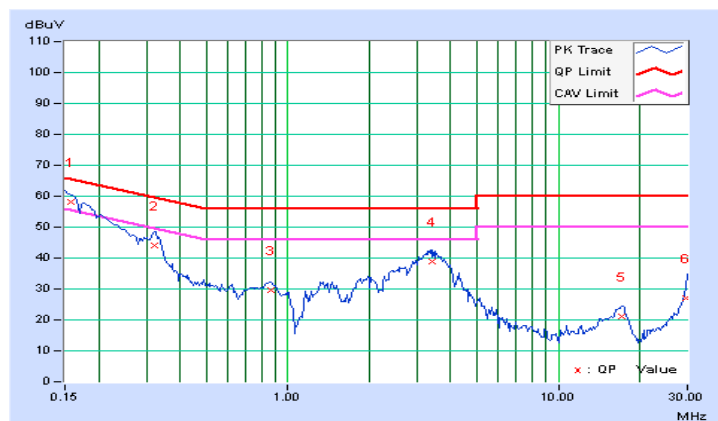



A D T

## **5.3 6dB BANDWIDTH MEASUREMENT**

### **5.3.1 LIMITS OF 6dB BANDWIDTH MEASUREMENT**

The minimum of 6dB Bandwidth Measurement is 0.5MHz.

### **5.3.2 TEST SETUP**

Same as section 4.3.2.

### **5.3.3 TEST INSTRUMENTS**

Refer to section 4.1.2 to get information of above instrument.

### **5.3.4 TEST PROCEDURE**

Same as section 4.3.4.

### **5.3.5 DEVIATION FROM TEST STANDARD**

No deviation.

### **5.3.6 EUT OPERATING CONDITIONS**

Same as section 4.3.6.



**5.3.7 TEST RESULTS**

**802.11a**

CHANNEL	FREQUENCY (MHz)	6dB BANDWIDTH (MHz)	MINIMUM LIMIT (MHz)	PASS / FAIL
149	5745	16.39	0.5	PASS
157	5785	16.38	0.5	PASS
165	5825	16.40	0.5	PASS

**802.11n (20MHz)**

CHANNEL	FREQUENCY (MHz)	6dB BANDWIDTH (MHz)	MINIMUM LIMIT (MHz)	PASS / FAIL
149	5745	17.61	0.5	PASS
157	5785	17.60	0.5	PASS
165	5825	17.60	0.5	PASS

**FOR 2TX**

CHANNEL	FREQUENCY (MHz)	6dB BANDWIDTH (MHz)		MINIMUM LIMIT (MHz)	PASS / FAIL
		CHAIN 0	CHAIN 1		
149	5745	17.61	17.65	0.5	PASS
157	5785	16.90	17.32	0.5	PASS
165	5825	16.90	17.61	0.5	PASS

**FOR 3TX**

CHANNEL	FREQUENCY (MHz)	6dB BANDWIDTH (MHz)			MINIMUM LIMIT (MHz)	PASS / FAIL
		CHAIN 0	CHAIN 1	CHAIN 2		
149	5745	17.62	17.61	17.62	0.5	PASS
157	5785	17.30	17.61	16.98	0.5	PASS
165	5825	17.62	17.63	17.60	0.5	PASS



A D T

**802.11n (40MHz)**

CHANNEL	FREQUENCY (MHz)	6dB BANDWIDTH (MHz)	MINIMUM LIMIT (MHz)	PASS / FAIL
151	5755	36.46	0.5	PASS
159	5795	36.46	0.5	PASS

**FOR 2TX**

CHANNEL	FREQUENCY (MHz)	6dB BANDWIDTH (MHz)		MINIMUM LIMIT (MHz)	PASS / FAIL
		CHAIN 0	CHAIN 1		
151	5755	36.42	36.44	0.5	PASS
159	5795	35.92	36.43	0.5	PASS

**FOR 3TX**

CHANNEL	FREQUENCY (MHz)	6dB BANDWIDTH (MHz)			MINIMUM LIMIT (MHz)	PASS / FAIL
		CHAIN 0	CHAIN 1	CHAIN 2		
151	5755	36.40	36.34	36.43	0.5	PASS
159	5795	36.12	36.41	36.46	0.5	PASS



A D T

**802.11ac (80MHz)**

CHANNEL	FREQUENCY (MHz)	6dB BANDWIDTH (MHz)	MINIMUM LIMIT (MHz)	PASS / FAIL
155	5775	76.48	0.5	PASS

**FOR 2TX**

CHANNEL	FREQUENCY (MHz)	6dB BANDWIDTH (MHz)		MINIMUM LIMIT (MHz)	PASS / FAIL
		CHAIN 0	CHAIN 1		
155	5775	74.65	76.37	0.5	PASS

**FOR 3TX**

CHANNEL	FREQUENCY (MHz)	6dB BANDWIDTH (MHz)			MINIMUM LIMIT (MHz)	PASS / FAIL
		CHAIN 0	CHAIN 1	CHAIN 2		
155	5775	75.22	75.82	75.24	0.5	PASS





A D T

### SPECTRUM PLOT OF WORST VALUE

#### 802.11a

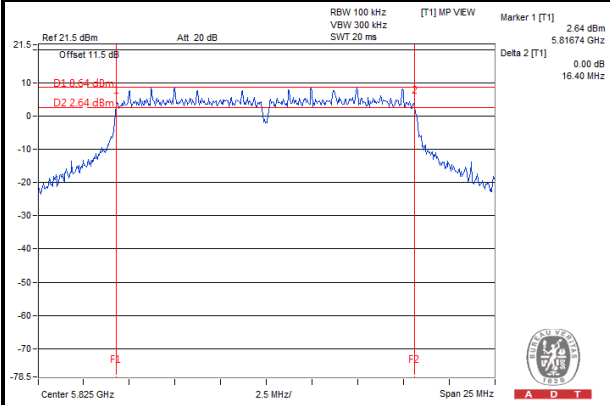

#### 802.11n (20MHz)

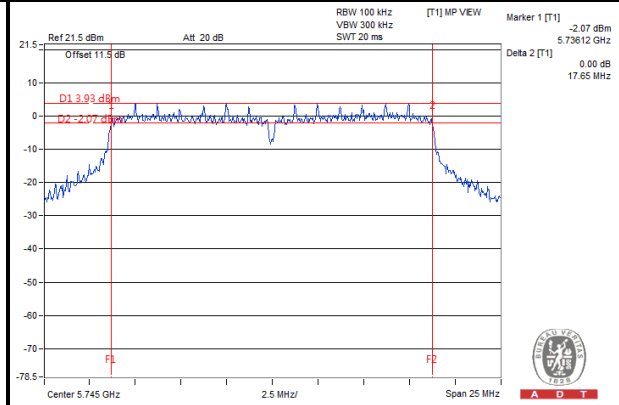

#### 802.11n (40MHz)

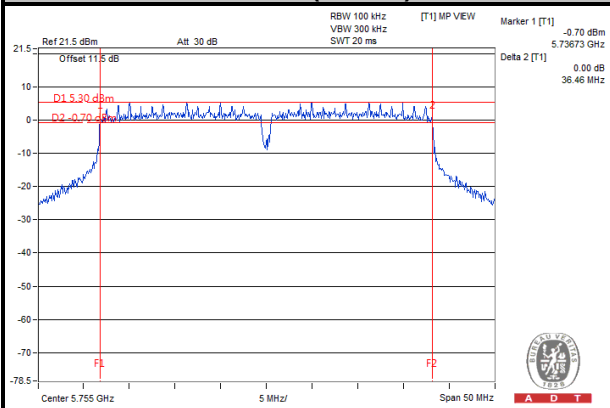

#### 802.11ac (80MHz)

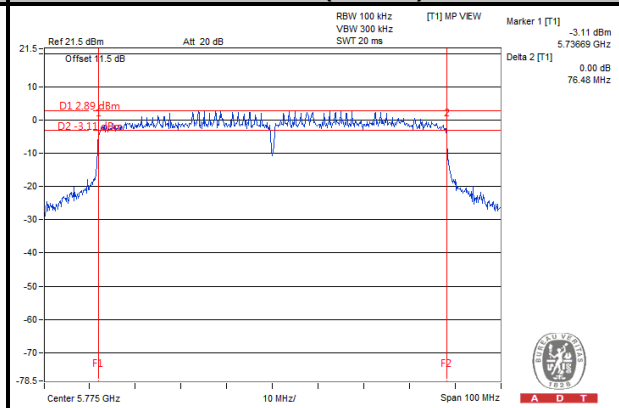

## **5.4 MAXIMUM OUTPUT POWER**

### **5.4.1 LIMITS OF MAXIMUM OUTPUT POWER MEASUREMENT**

For systems using digital modulation in the 5725–5850 MHz bands: 1 Watt (30dBm)

Per KDB 662911 D01 Multiple Transmitter Output v02r01 Method of conducted output power measurement on IEEE 802.11 devices,

Array Gain = 0 dB (i.e., no array gain) for  $NANT \leq 4$ ;

Array Gain = 0 dB (i.e., no array gain) for channel widths  $\geq 40$  MHz for any NANT;

Array Gain =  $5 \log(NANT/NSS)$  dB or 3 dB, whichever is less for 20-MHz channel widths with  $NANT \geq 5$ .

For power measurements on all other devices: Array Gain =  $10 \log(NANT/NSS)$  dB.

### **5.4.2 TEST SETUP**

Same as section 4.4.2.

### **5.4.3 INSTRUMENTS**

Refer to section 4.1.2 to get information of above instrument.

### **5.4.4 TEST PROCEDURES**

Same as section 4.4.4.

### **5.4.5 DEVIATION FROM TEST STANDARD**

No deviation.

### **5.4.6 EUT OPERATING CONDITIONS**

Same as section 4.3.6.

### 5.4.7 TEST RESULTS

#### 802.11a

CHANNEL	FREQUENCY (MHz)	PEAK POWER (mW)	PEAK POWER (dBm)	LIMIT (dBm)	PASS / FAIL
149	5745	316.96	25.01	30	PASS
157	5785	305.49	24.85	30	PASS
165	5825	291.07	24.64	30	PASS

#### 802.11n (20MHz)

CHANNEL	FREQUENCY (MHz)	PEAK POWER (mW)	PEAK POWER (dBm)	LIMIT (dBm)	PASS / FAIL
149	5745	328.10	25.16	30	PASS
157	5785	313.33	24.96	30	PASS
165	5825	314.77	24.98	30	PASS

#### FOR 2TX

CHAN.	FREQ. (MHz)	PEAK POWER (dBm)		TOTAL POWER (mW)	TOTAL POWER (dBm)	LIMIT (dBm)	PASS / FAIL
		CHAIN 0	CHAIN 1				
149	5745	21.03	22.22	293.490	24.68	30	PASS
157	5785	21.07	22.51	306.176	24.86	30	PASS
165	5825	20.74	22.58	299.711	24.77	30	PASS

#### FOR 3TX

CHAN.	FREQ. (MHz)	PEAK POWER (dBm)			TOTAL POWER (mW)	TOTAL POWER (dBm)	LIMIT (dBm)	PASS / FAIL
		CHAIN 0	CHAIN 1	CHAIN 2				
149	5745	20.09	20.80	19.24	306.266	24.86	30	PASS
157	5785	20.15	21.12	19.24	316.880	25.01	30	PASS
165	5825	19.32	21.03	18.93	290.435	24.63	30	PASS



A D T

**802.11n (40MHz)**

CHANNEL	FREQUENCY (MHz)	PEAK POWER (mW)	PEAK POWER (dBm)	LIMIT (dBm)	PASS / FAIL
151	5755	285.10	24.55	30	PASS
159	5795	270.40	24.32	30	PASS

**FOR 2TX**

CHAN.	FREQ. (MHz)	PEAK POWER (dBm)		TOTAL POWER (mW)	TOTAL POWER (dBm)	LIMIT (dBm)	PASS / FAIL
		CHAIN 0	CHAIN 1				
151	5755	21.44	22.47	315.919	25.00	30	PASS
159	5795	21.59	22.57	324.929	25.12	30	PASS

**FOR 3TX**

CHAN.	FREQ. (MHz)	PEAK POWER (dBm)			TOTAL POWER (mW)	TOTAL POWER (dBm)	LIMIT (dBm)	PASS / FAIL
		CHAIN 0	CHAIN 1	CHAIN 2				
151	5755	19.99	21.04	19.70	320.153	25.05	30	PASS
159	5795	19.96	21.33	19.33	320.618	25.06	30	PASS

**802.11ac (80MHz)**

CHANNEL	FREQUENCY (MHz)	PEAK POWER (mW)	PEAK POWER (dBm)	LIMIT (dBm)	PASS / FAIL
155	5775	716.14	28.55	30	PASS

**FOR 2TX**

CHAN.	FREQ. (MHz)	PEAK POWER (dBm)		TOTAL POWER (mW)	TOTAL POWER (dBm)	LIMIT (dBm)	PASS / FAIL
		CHAIN 0	CHAIN 1				
155	5775	25.74	26.58	829.961	29.19	30	PASS

**FOR 3TX**

CHAN.	FREQ. (MHz)	PEAK POWER (dBm)			TOTAL POWER (mW)	TOTAL POWER (dBm)	LIMIT (dBm)	PASS / FAIL
		CHAIN 0	CHAIN 1	CHAIN 2				
155	5775	24.08	24.92	23.90	811.785	29.09	30	PASS



A D T

## **5.5 POWER SPECTRAL DENSITY MEASUREMENT**

### **5.5.1 LIMITS OF POWER SPECTRAL DENSITY MEASUREMENT**

The Maximum of Power Spectral Density Measurement is 8dBm.

### **5.5.2 TEST SETUP**

Same as section 4.5.2.

### **5.5.3 TEST INSTRUMENTS**

Refer to section 4.1.2 to get information of above instrument.

### **5.5.4 TEST PROCEDURE.**

Same as section 4.5.4.

### **5.5.5 DEVIATION FROM TEST STANDARD**

No deviation.

### **5.5.6 EUT OPERATING CONDITION**

Same as section 4.3.6.

### 5.5.7 TEST RESULTS

#### 802.11a

CHANNEL	FREQUENCY (MHz)	PSD (dBm/3kHz)	LIMIT (dBm/3kHz)	PASS / FAIL
149	5745	-6.97	8	PASS
157	5785	-6.52	8	PASS
165	5825	-6.02	8	PASS

#### 802.11n (20MHz)

CHANNEL	FREQUENCY (MHz)	PSD (dBm/3kHz)	LIMIT (dBm/3kHz)	PASS / FAIL
149	5745	-6.96	8	PASS
157	5785	-7.19	8	PASS
165	5825	-6.36	8	PASS

#### FOR 2TX

TX Chain	Channel	Freq. (MHz)	PSD (dBm/3kHz)	10 log (N=2) dB	Total PSD (dBm/3kHz)	Limit (dBm/3kHz)	PASS /FAIL
0	149	5745	-10.96	3.01	-7.95	6.53	PASS
	157	5785	-9.40	3.01	-6.39	6.53	PASS
	165	5825	-10.71	3.01	-7.70	6.53	PASS
1	149	5745	-10.40	3.01	-7.39	6.53	PASS
	157	5785	-9.22	3.01	-6.21	6.53	PASS
	165	5825	-7.82	3.01	-4.81	6.53	PASS

**NOTE:** Directional gain =  $10 \log[(10^{G1/20} + 10^{G2/20} + \dots + 10^{GN/20})^2 / N_{ANT}] = 7.47\text{dBi} > 6\text{dBi}$  , so the power density limit shall be reduced to  $8-(7.47-6) = 6.53\text{dBm}$ .



A D T

**FOR 3TX**

TX Chain	Channel	Freq. (MHz)	PSD (dBm/3kHz)	10 log (N=3) dB	Total PSD (dBm/3kHz)	Limit (dBm/3kHz)	PASS /FAIL
0	149	5745	-12.39	4.77	-7.62	4.93	PASS
	157	5785	-11.02	4.77	-6.25	4.93	PASS
	165	5825	-11.79	4.77	-7.02	4.93	PASS
1	149	5745	-11.97	4.77	-7.20	4.93	PASS
	157	5785	-10.01	4.77	-5.24	4.93	PASS
	165	5825	-9.69	4.77	-4.92	4.93	PASS
2	149	5745	-10.84	4.77	-6.07	4.93	PASS
	157	5785	-12.09	4.77	-7.32	4.93	PASS
	165	5825	-12.09	4.77	-7.32	4.93	PASS

**NOTE:** Directional gain =  $10 \log[(10^{G1/20} + 10^{G2/20} + \dots + 10^{GN/20})^2 / N_{ANT}] = 9.07\text{dBi} > 6\text{dBi}$  , so the power density limit shall be reduced to  $8-(9.07-6) = 4.93\text{dBm}$ .



A D T

**802.11n (40MHz)**

CHANNEL	FREQUENCY (MHz)	PSD (dBm/3kHz)	LIMIT (dBm/3kHz)	PASS / FAIL
151	5755	-8.23	8	PASS
159	5795	-9.52	8	PASS

**FOR 2TX**

TX Chain	Channel	Freq. (MHz)	PSD (dBm/3kHz)	10 log (N=2) dB	Total PSD (dBm/3kHz)	Limit (dBm/3kHz)	PASS /FAIL
0	151	5755	-12.34	3.01	-9.33	6.53	PASS
	159	5795	-12.30	3.01	-9.29	6.53	PASS
1	151	5755	-12.23	3.01	-9.22	6.53	PASS
	159	5795	-11.34	3.01	-8.33	6.53	PASS

**NOTE:** Directional gain =  $10 \log[(10^{G1/20} + 10^{G2/20} + \dots + 10^{GN/20})^2 / N_{ANT}] = 7.47\text{dBi} > 6\text{dBi}$  , so the power density limit shall be reduced to  $8-(7.47-6) = 6.53\text{dBm}$ .

**FOR 3TX**

TX Chain	Channel	Freq. (MHz)	PSD (dBm/3kHz)	10 log (N=3) dB	Total PSD (dBm/3kHz)	Limit (dBm/3kHz)	PASS /FAIL
0	151	5755	-12.98	4.77	-8.21	4.93	PASS
	159	5795	-13.54	4.77	-8.77	4.93	PASS
1	151	5755	-12.48	4.77	-7.71	4.93	PASS
	159	5795	-12.21	4.77	-7.44	4.93	PASS
2	151	5755	-14.54	4.77	-9.77	4.93	PASS
	159	5795	-14.03	4.77	-9.26	4.93	PASS

**NOTE:** Directional gain =  $10 \log[(10^{G1/20} + 10^{G2/20} + \dots + 10^{GN/20})^2 / N_{ANT}] = 9.07\text{dBi} > 6\text{dBi}$  , so the power density limit shall be reduced to  $8-(9.07-6) = 4.93\text{dBm}$ .





A D T

**802.11ac (80MHz)**

CHANNEL	FREQUENCY (MHz)	PSD (dBm/3kHz)	LIMIT (dBm/3kHz)	PASS / FAIL
155	5775	-10.81	8	PASS

**FOR 2TX**

TX Chain	Channel	Freq. (MHz)	PSD (dBm/3kHz)	10 log (N=2) dB	Total PSD (dBm/3kHz)	Limit (dBm/3kHz)	PASS /FAIL
0	155	5775	-15.27	3.01	-12.26	6.53	PASS
1	155	5775	-15.39	3.01	-12.38	6.53	PASS

**NOTE:** Directional gain =  $10 \log[(10^{G1/20} + 10^{G2/20} + \dots + 10^{GN/20})^2 / N_{ANT}] = 7.47\text{dBi} > 6\text{dBi}$  , so the power density limit shall be reduced to  $8-(7.47-6) = 6.53\text{dBm}$ .

**FOR 3TX**

TX Chain	Channel	Freq. (MHz)	PSD (dBm/3kHz)	10 log (N=3) dB	Total PSD (dBm/3kHz)	Limit (dBm/3kHz)	PASS /FAIL
0	155	5775	-15.92	4.77	-11.15	4.93	PASS
1	155	5775	-14.97	4.77	-10.20	4.93	PASS
2	155	5775	-15.99	4.77	-11.22	4.93	PASS

**NOTE:** Directional gain =  $10 \log[(10^{G1/20} + 10^{G2/20} + \dots + 10^{GN/20})^2 / N_{ANT}] = 9.07\text{dBi} > 6\text{dBi}$  , so the power density limit shall be reduced to  $8-(9.07-6) = 4.93\text{dBm}$ .



A D T

### SPECTRUM PLOT OF WORST VALUE

#### 802.11a

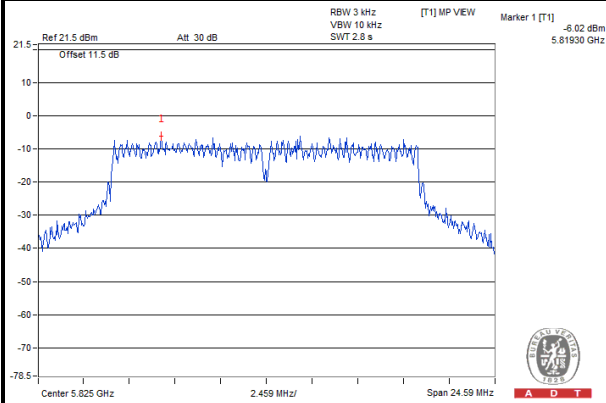

#### 802.11n (20MHz)

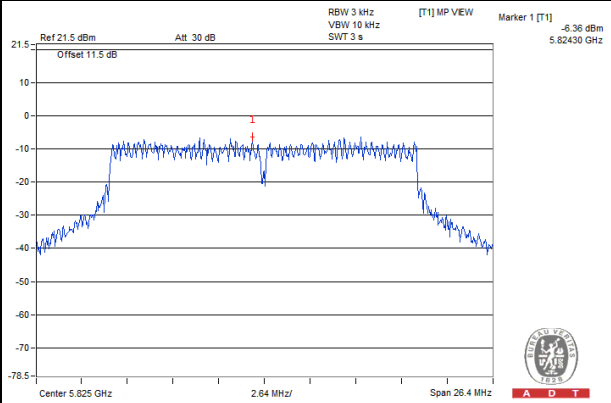

#### 802.11n (40MHz)

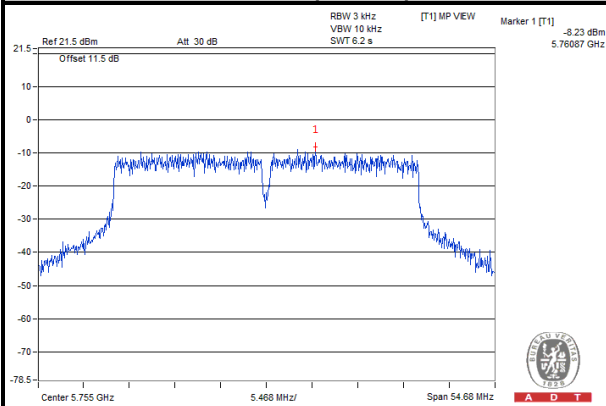

#### 802.11ac (80MHz)

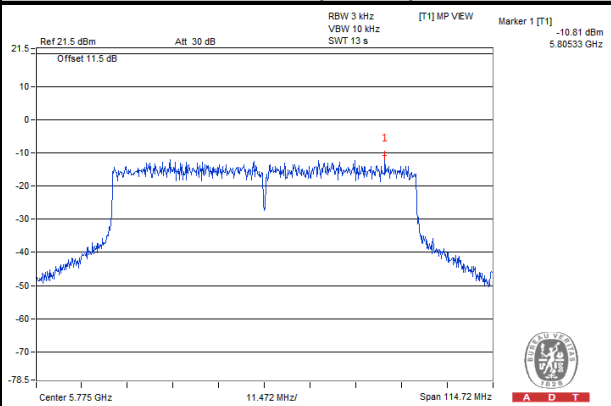

## **5.6 CONDUCTED OUT OF BAND EMISSION MEASUREMENT**

### **5.6.1 LIMITS OF OUT OF BAND EMISSION MEASUREMENT**

Below  $-20\text{dB}$  of the highest emission level of operating band (in 100kHz Resolution Bandwidth).

### **5.6.2 TEST SETUP**

Same as section 4.6.2.

### **5.6.3 TEST INSTRUMENTS**

Refer to section 4.1.2 to get information of above instrument.

### **5.6.4 TEST PROCEDURE**

Same as section 4.6.4

### **5.6.5 DEVIATION FROM TEST STANDARD**

No deviation.

### **5.6.6 EUT OPERATING CONDITION**

Same as section 4.3.6

### **5.6.7 TEST RESULTS**

The spectrum plots are attached on the following pages. D1 line indicates the highest level, and D2 line indicates the 20dB offset below D1. It shows compliance with the requirement.



A D T

802.11a

CH 149

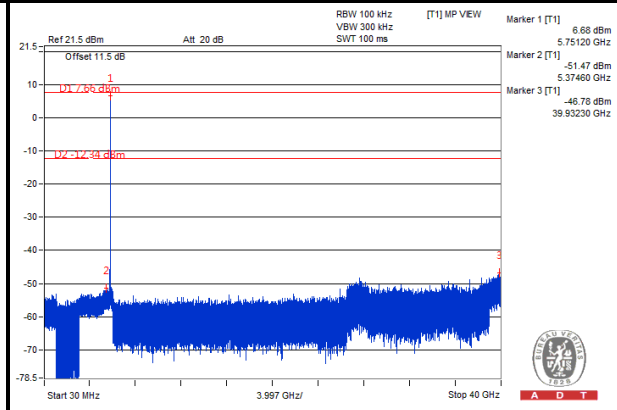
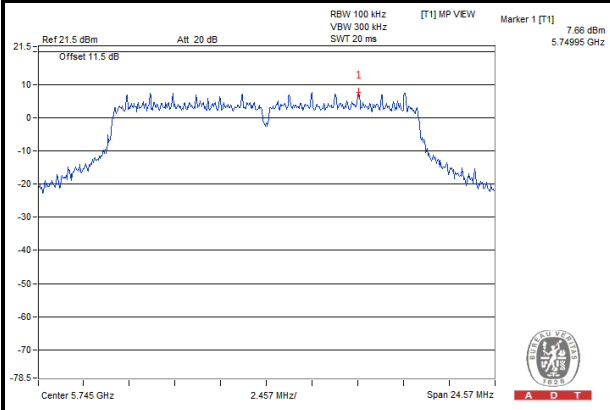

CH 157

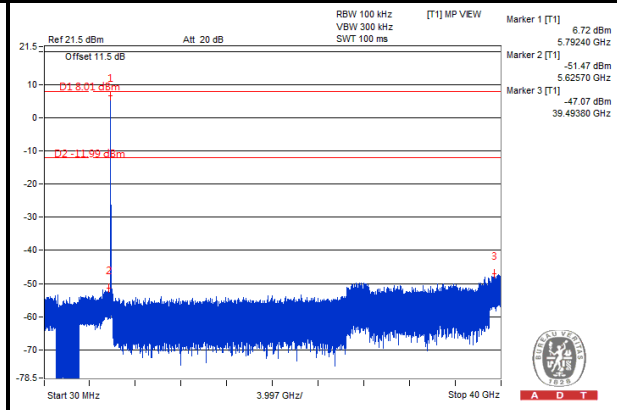
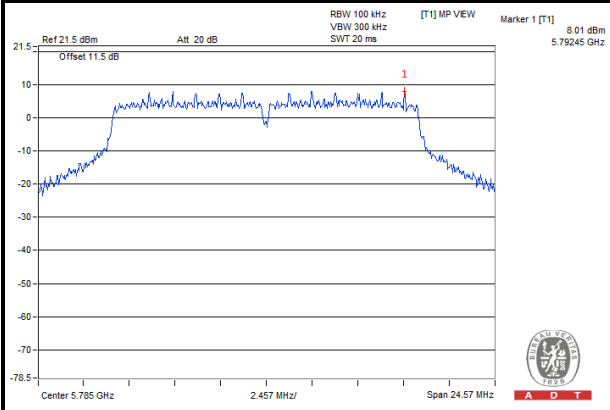

CH 165

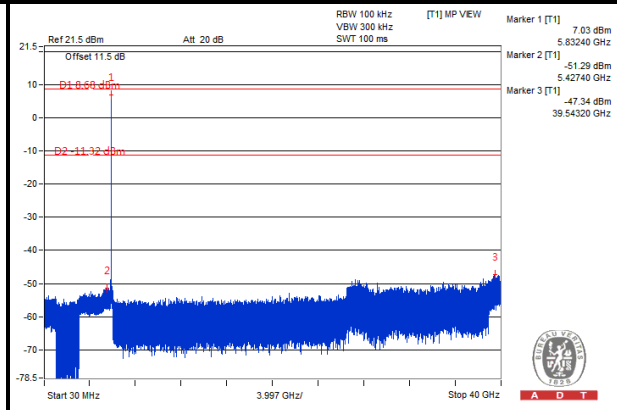
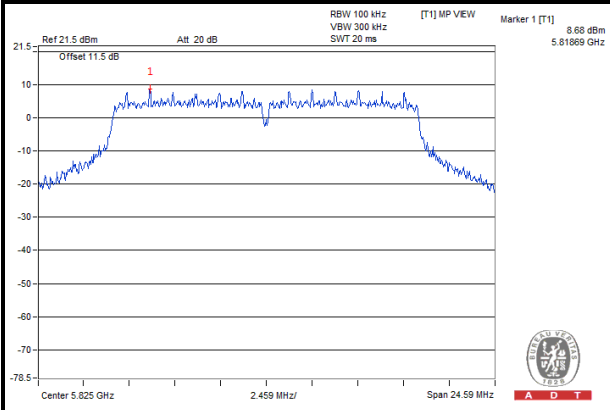



A D T

### 802.11n (20MHz)

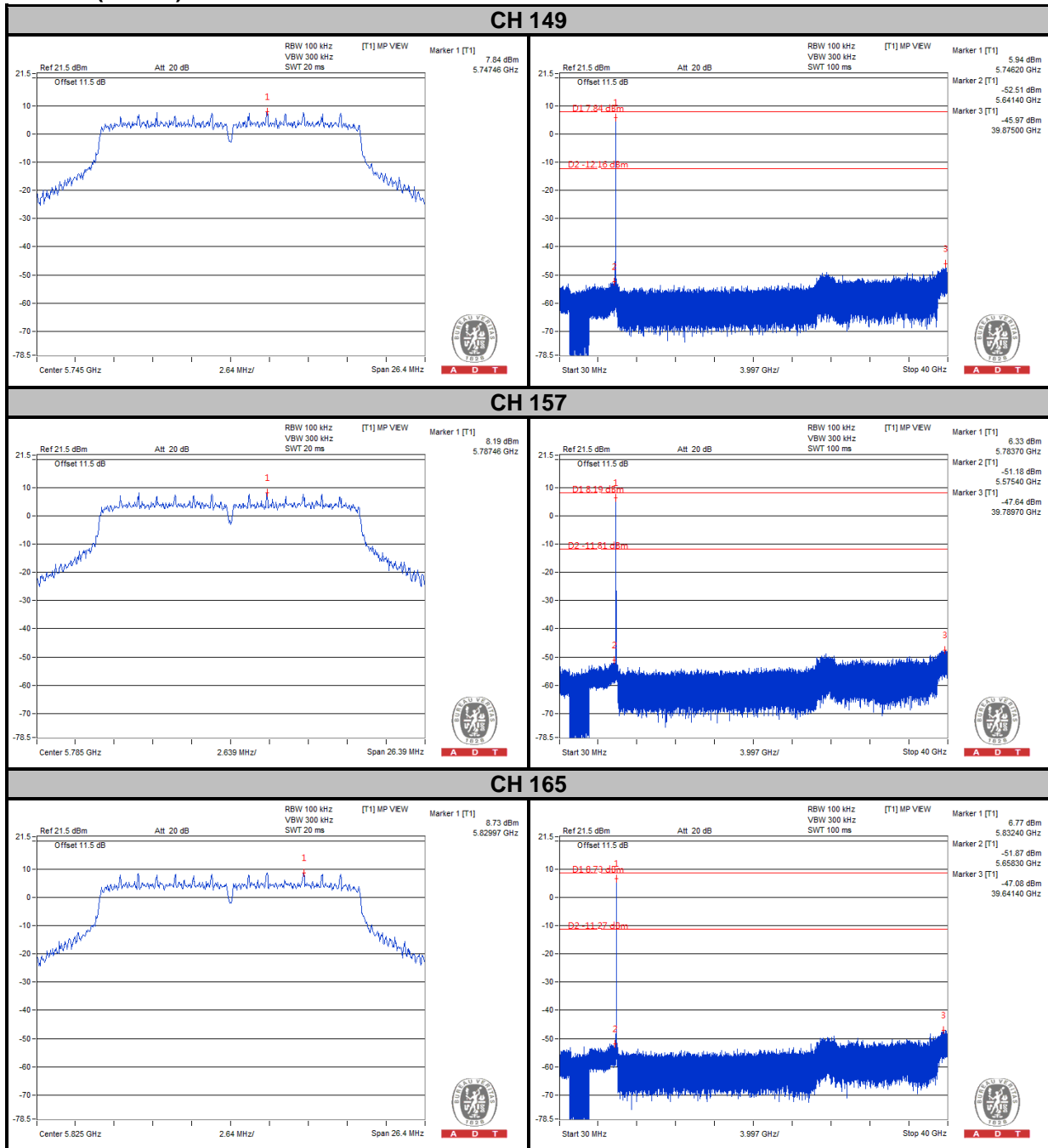



A D T

# 2TX CHAIN 0

## CH 149

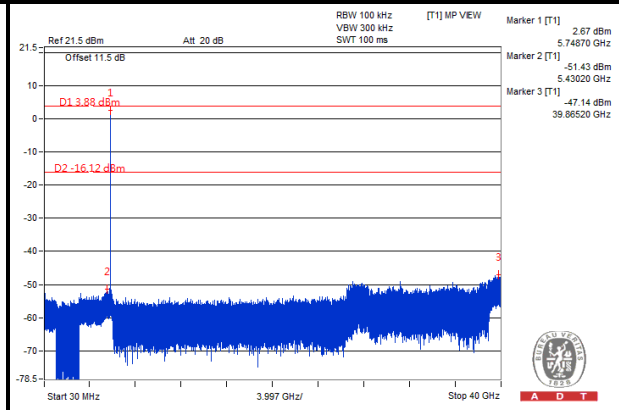
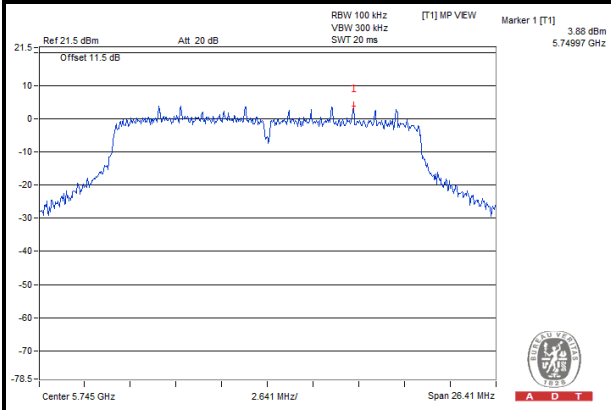

## CH 157

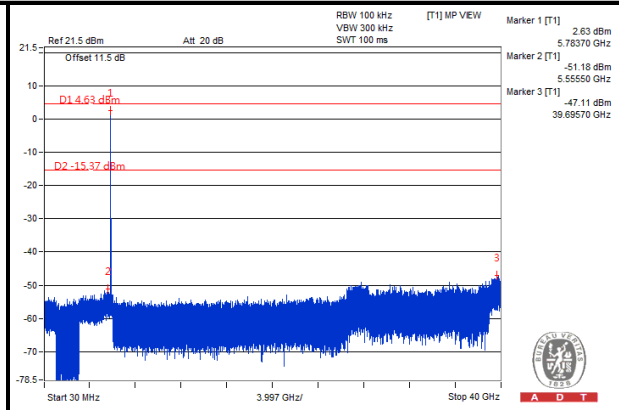
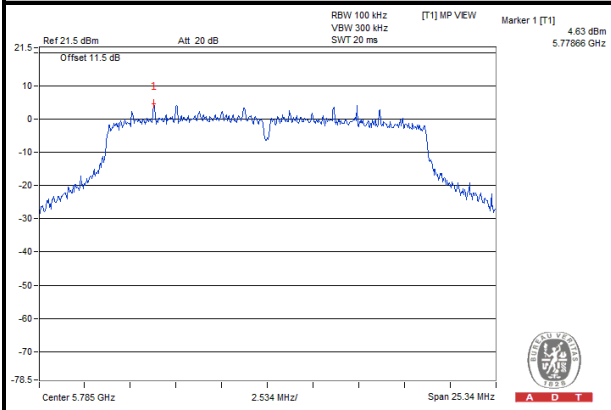

## CH 165

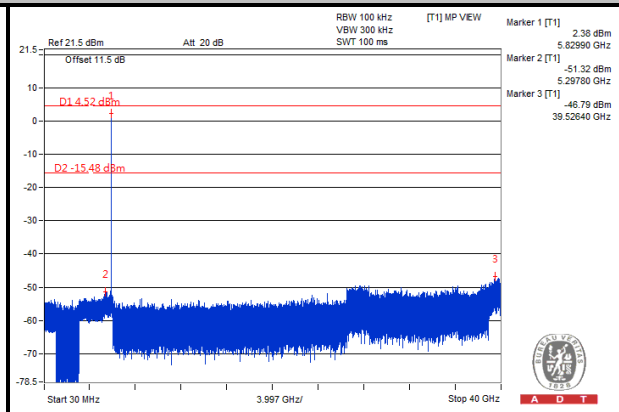
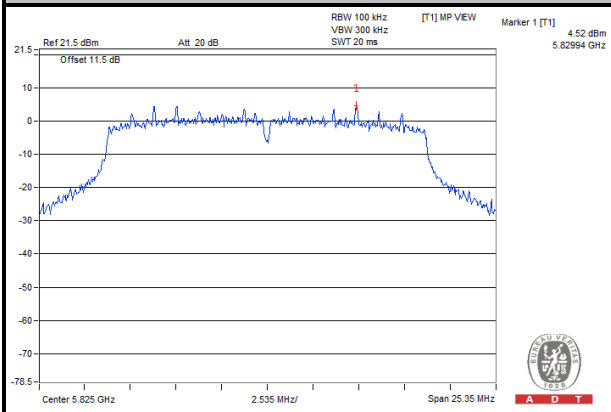



A D T

# CHAIN 1

## CH 149

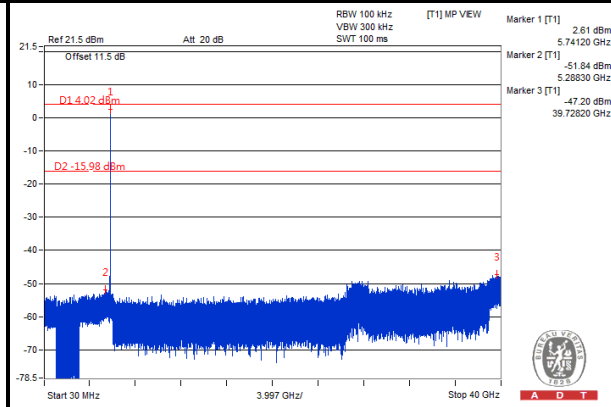
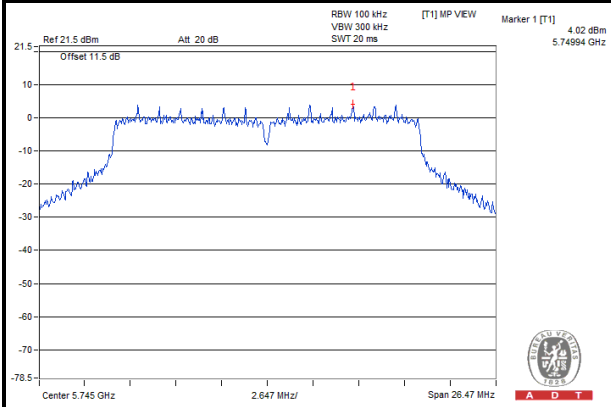

## CH 157

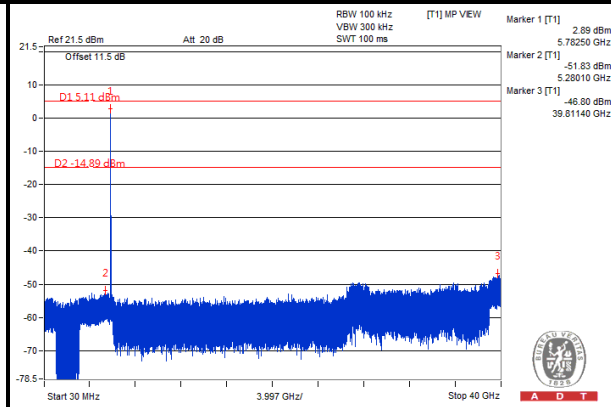
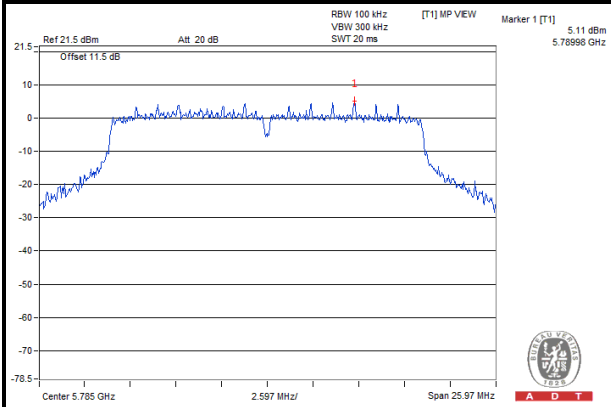

## CH 165

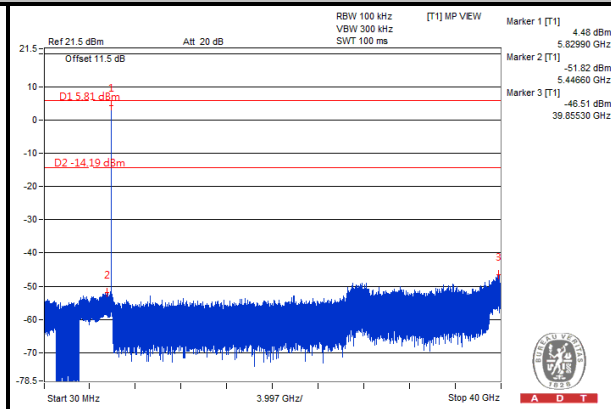
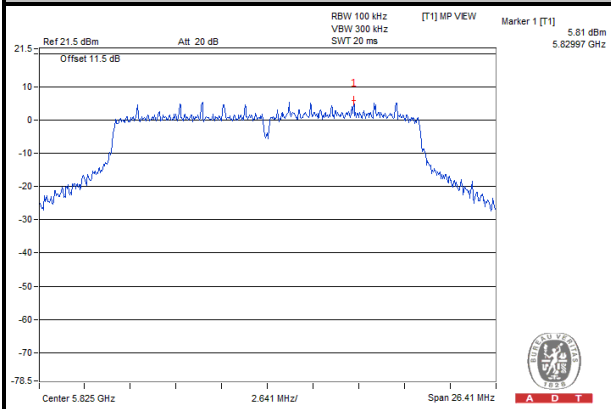



A D T

### 3TX CHAIN 0

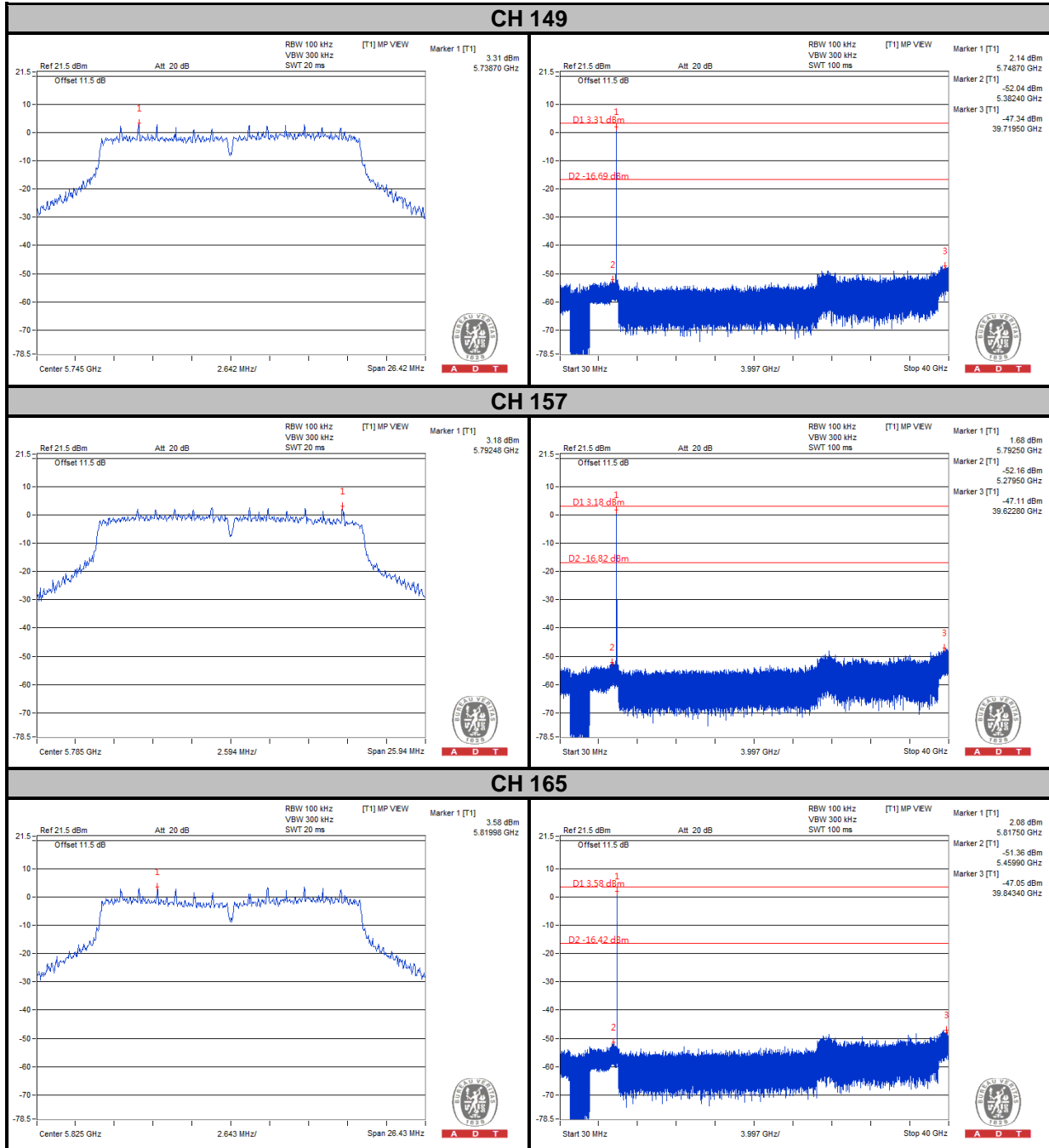





A D T

# CHAIN 1

## CH 149

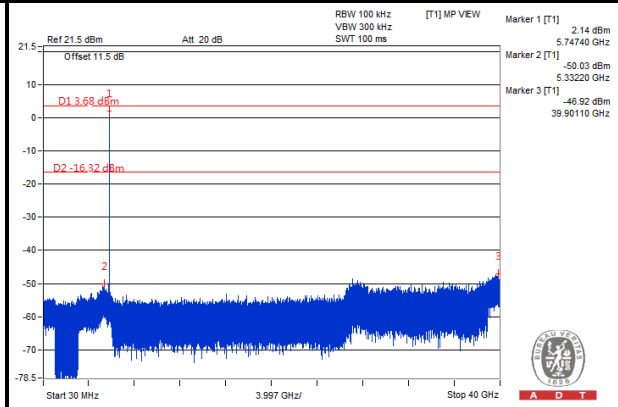
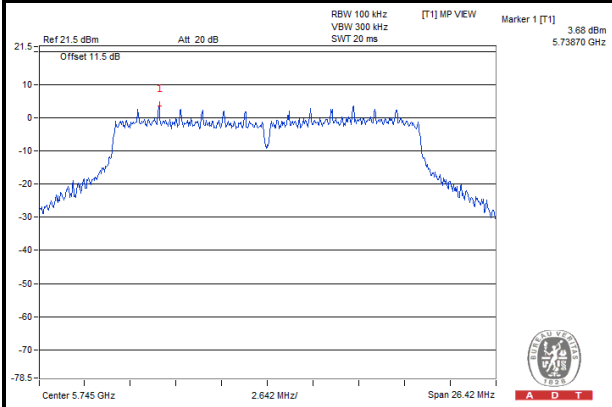

## CH 157

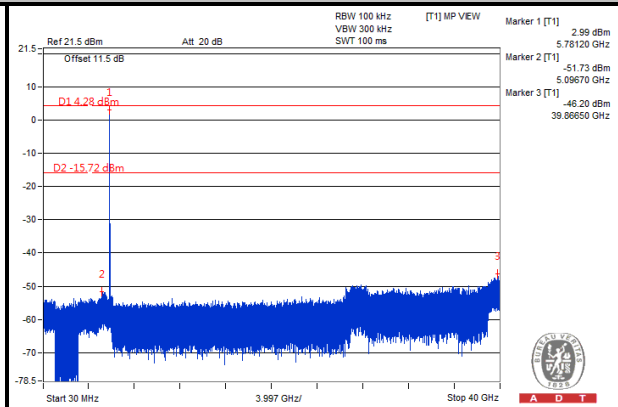
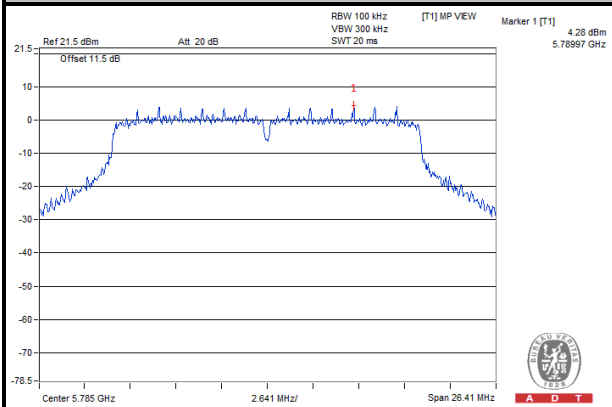

## CH 165

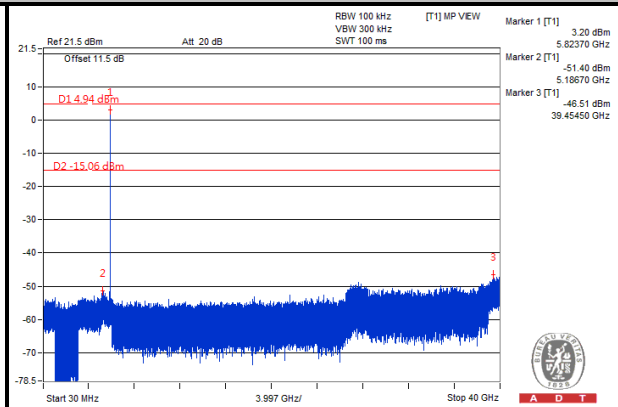
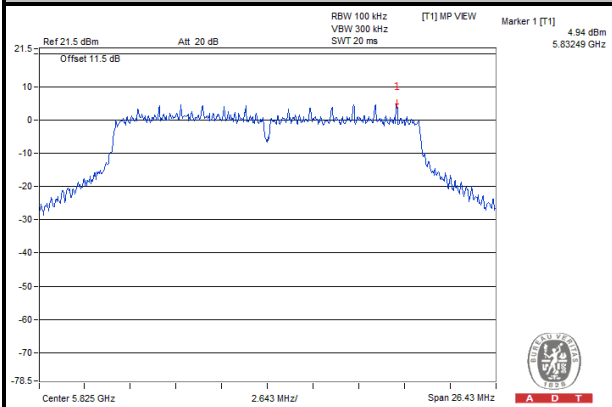



A D T

### CHAIN 2

#### CH 149

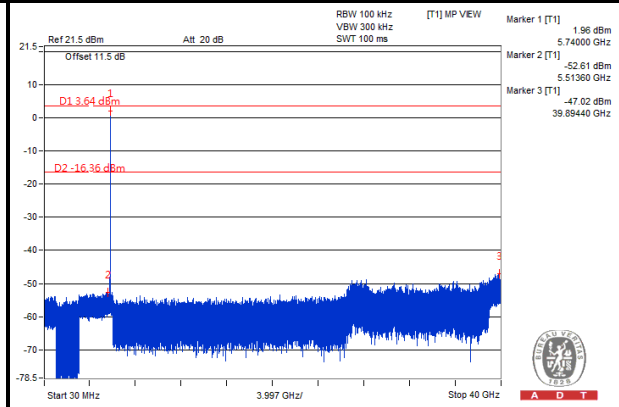
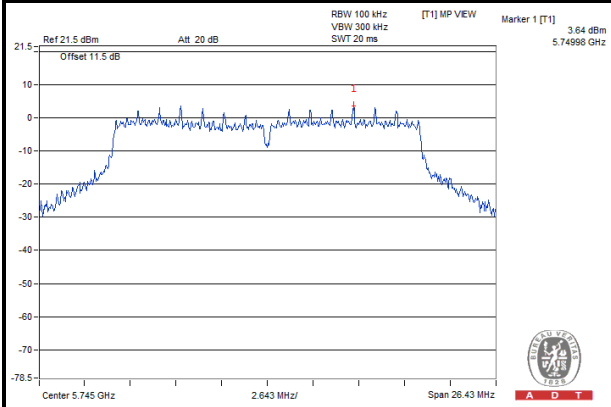

#### CH 157

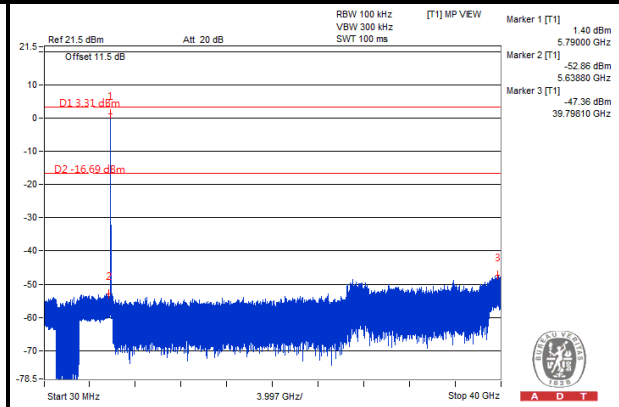
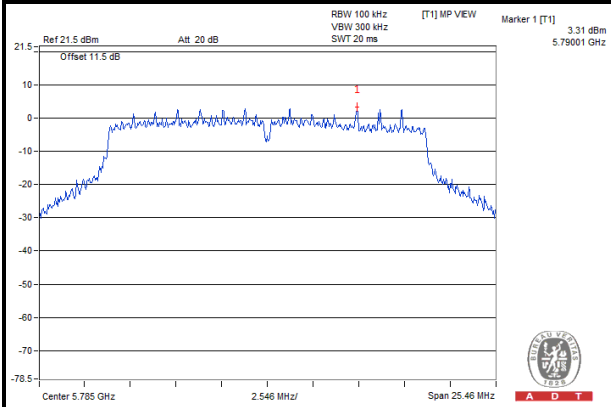

#### CH 165

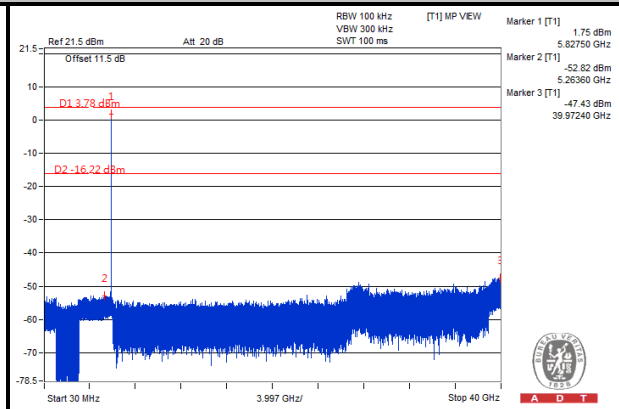
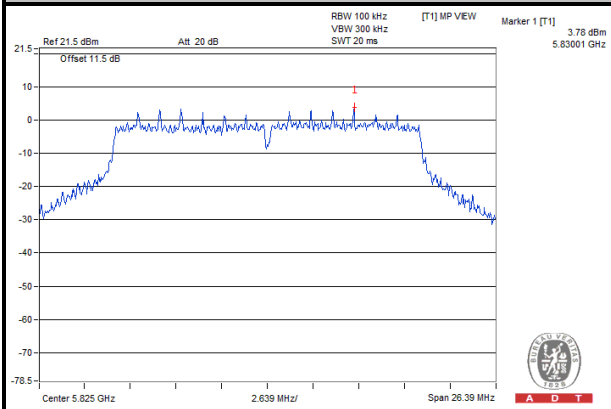



A D T

### 802.11n (40MHz)

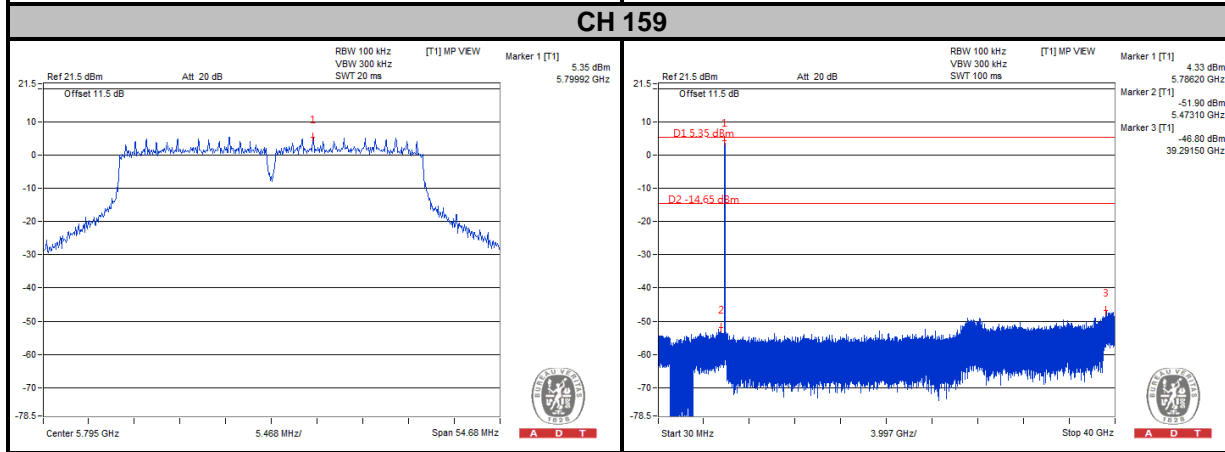
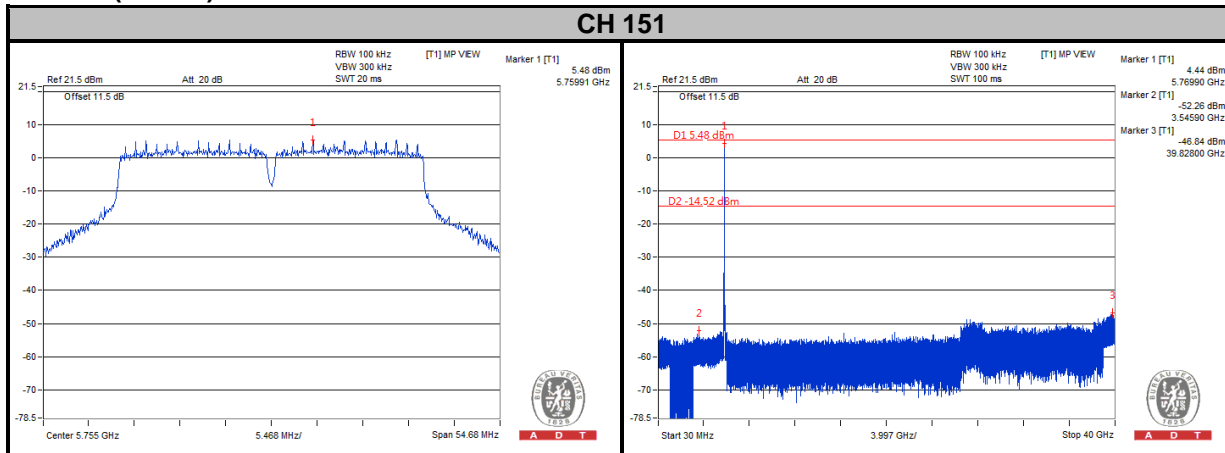



A D T

# 2TX CHAIN 0

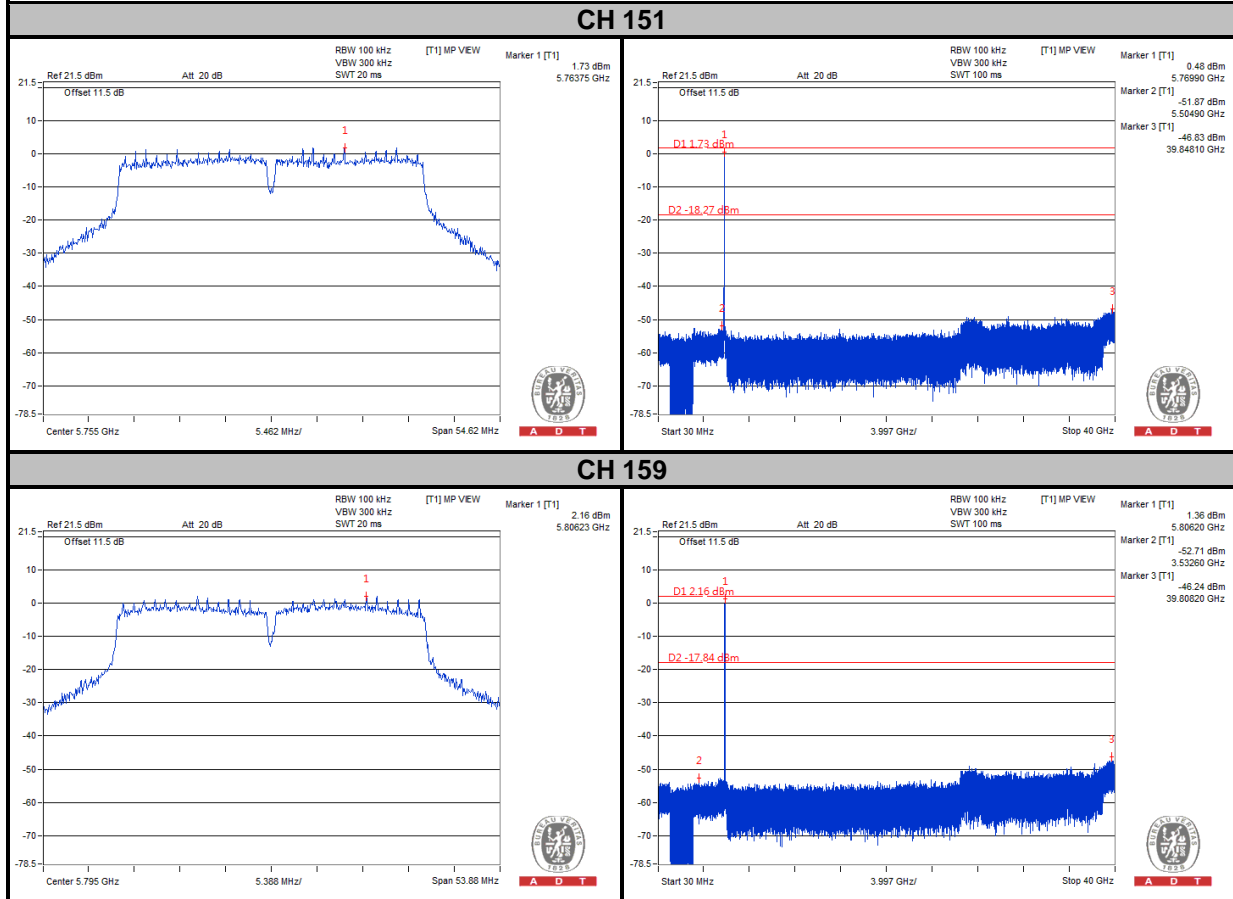



A D T

# CHAIN 1

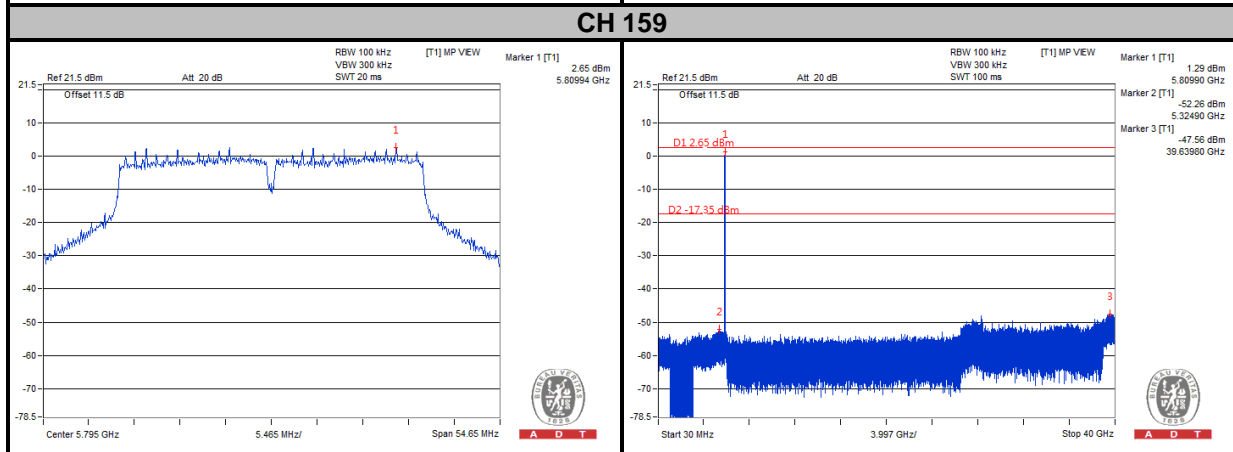
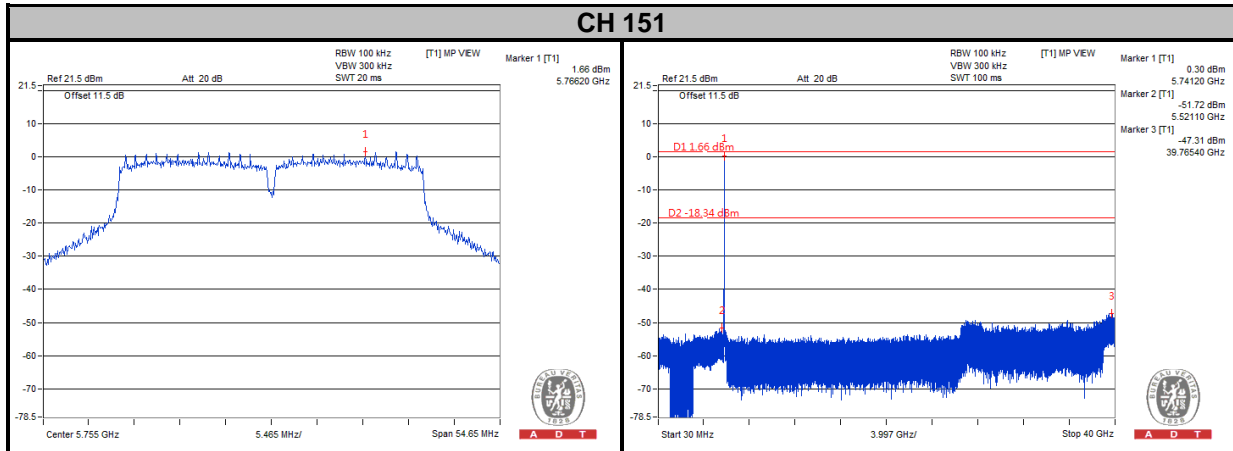



A D T

### 3TX CHAIN 0

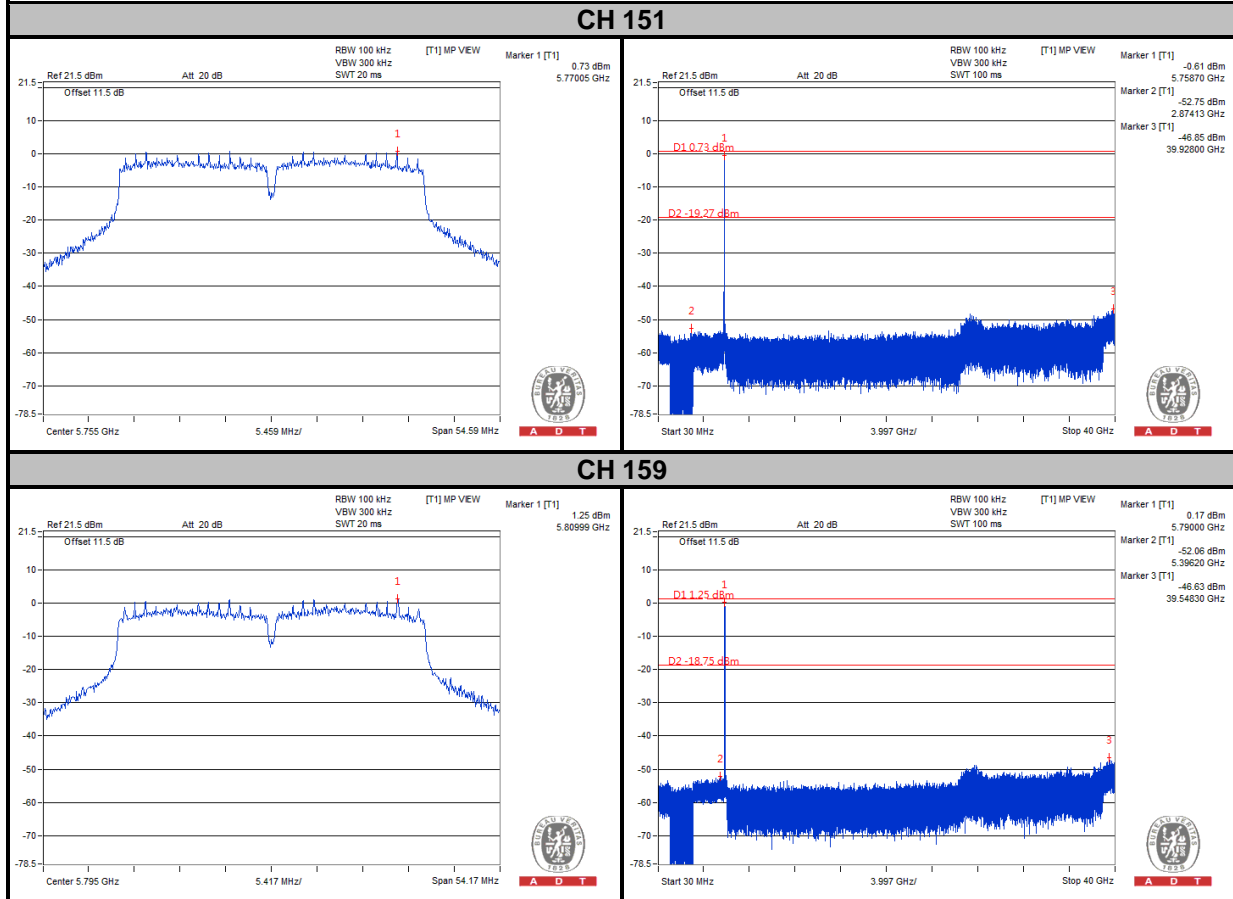



A D T

# CHAIN 1

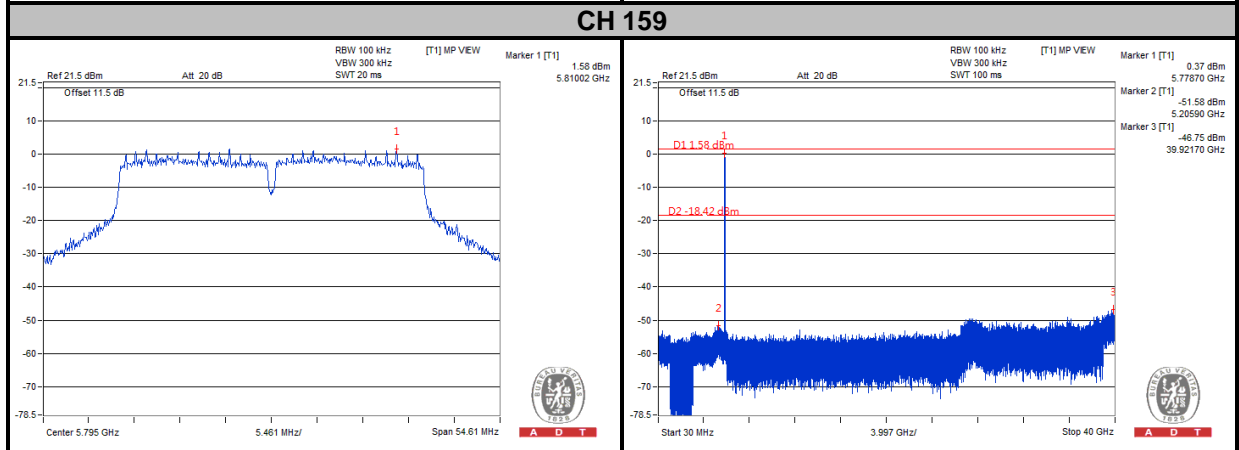
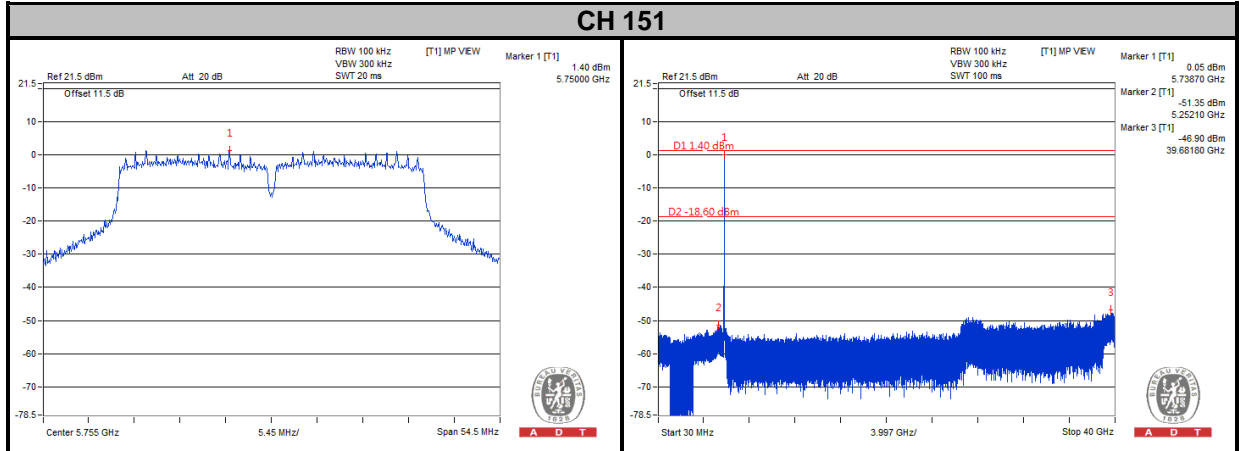



A D T

### CHAIN 2

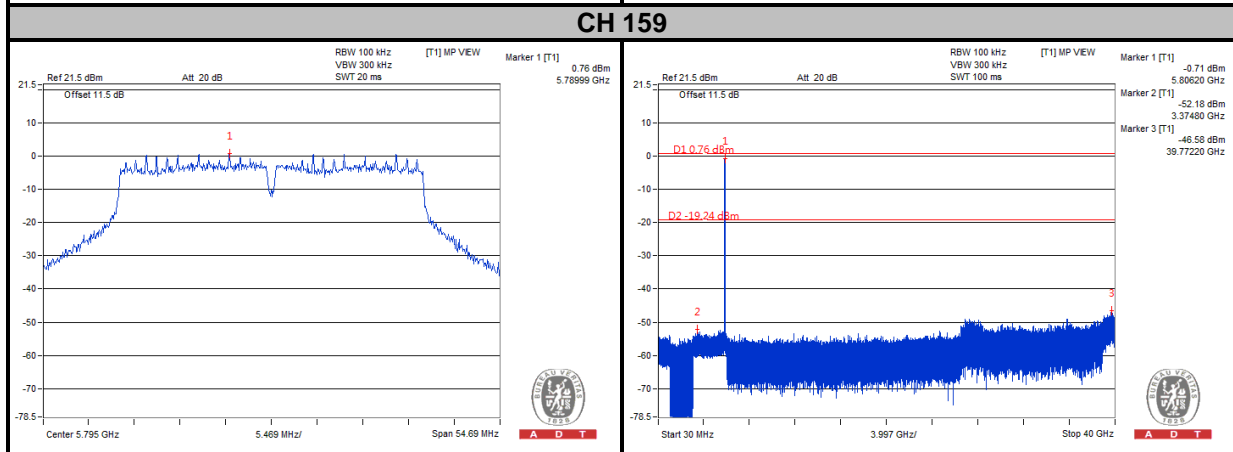
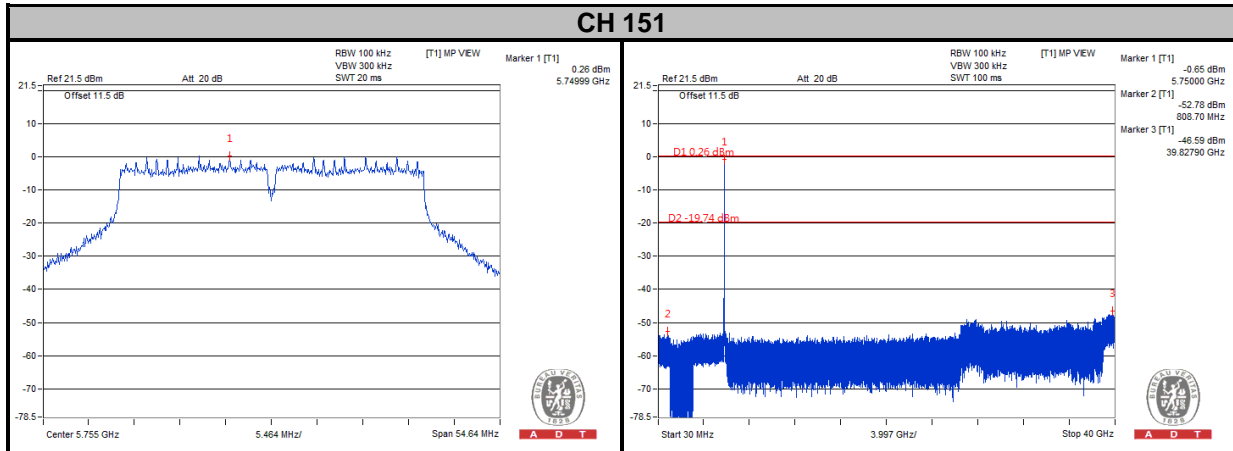





A D T

### 802.11ac (80MHz)

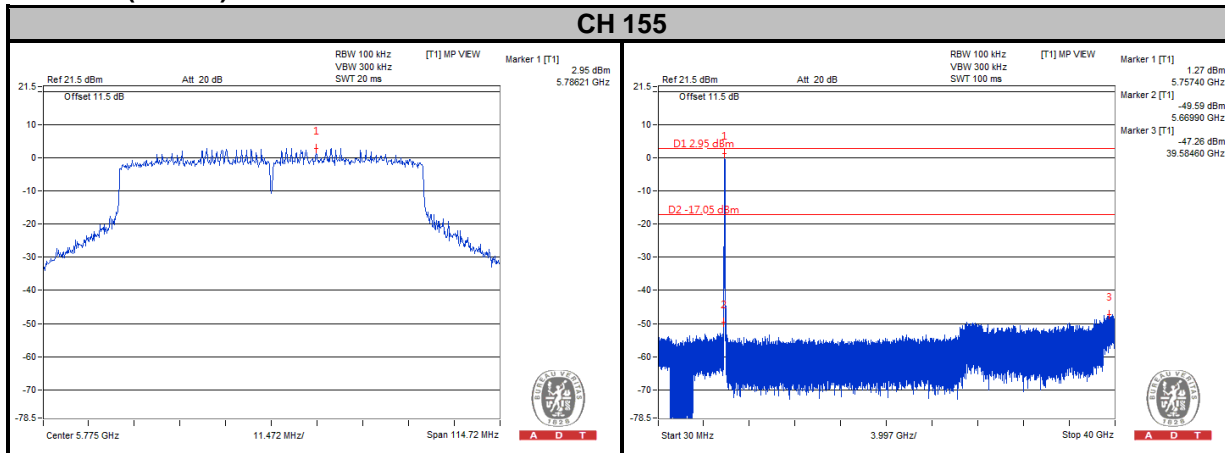

### 2TX CHAIN 0

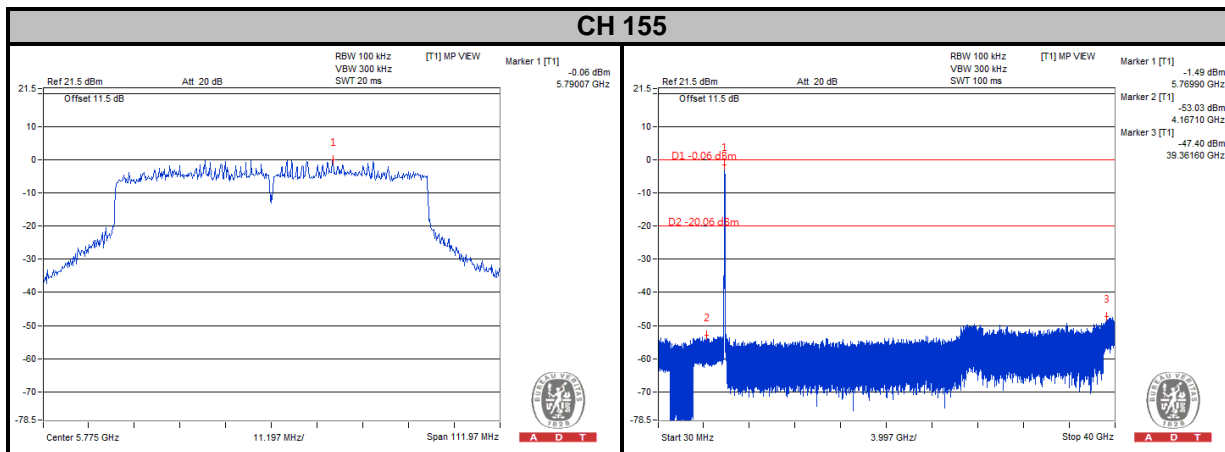

### CHAIN 1

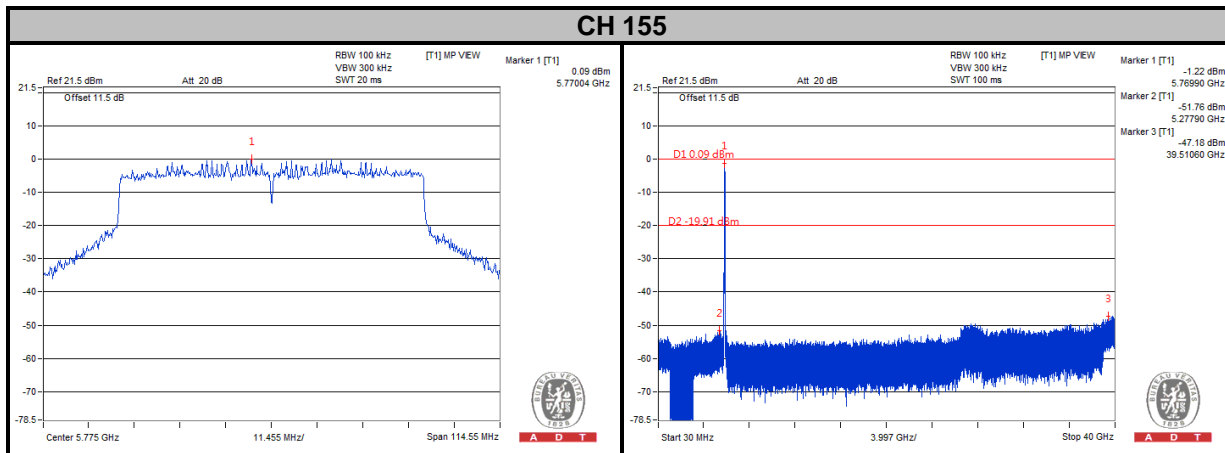



A D T

### 3TX CHAIN 0

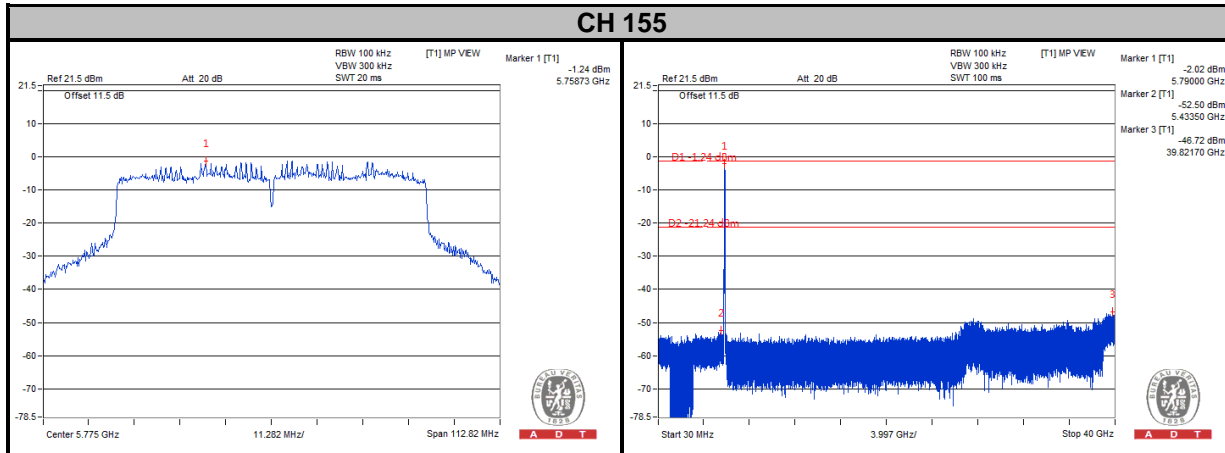

### CHAIN 1

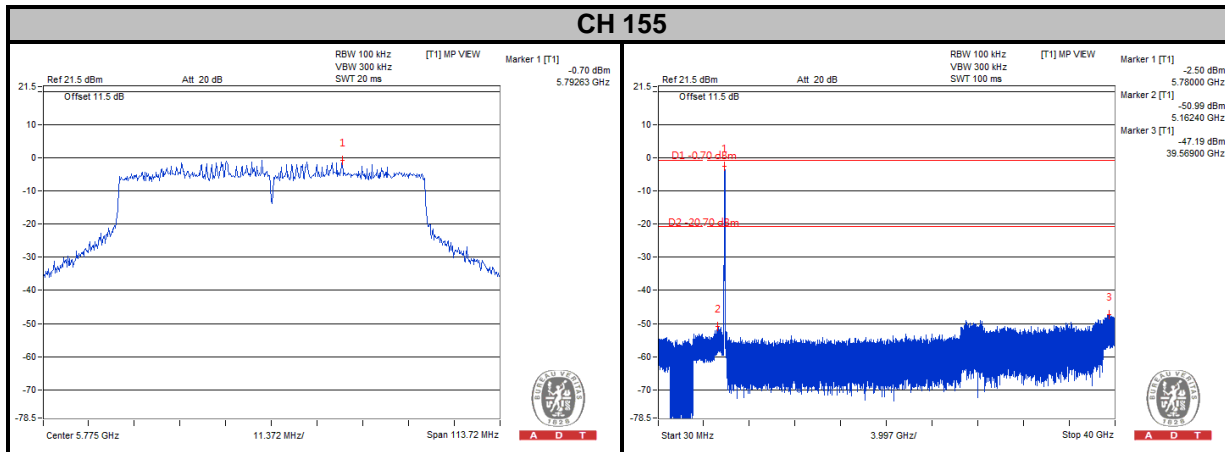

### CHAIN 2

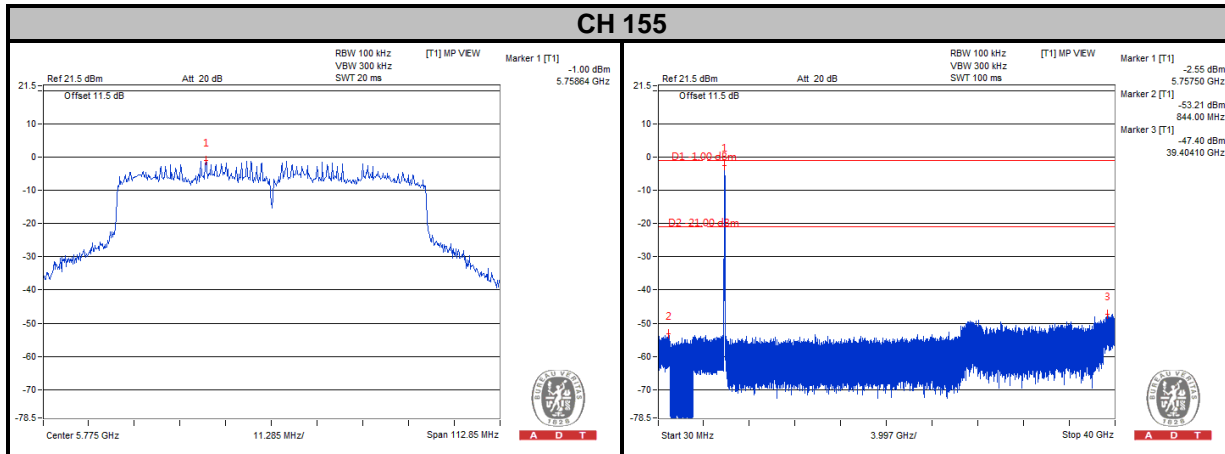



A D T

## 6. PHOTOGRAPHS OF THE TEST CONFIGURATION

Please refer to the attached file (Test Setup Photo).



## 7. INFORMATION ON THE TESTING LABORATORIES

We, Bureau Veritas Consumer Products Services (H.K.) Ltd., Taoyuan Branch, were founded in 1988 to provide our best service in EMC, Radio, Telecom and Safety consultation. Our laboratories are accredited and approved according to ISO/IEC 17025.

If you have any comments, please feel free to contact us at the following:

**Linko EMC/RF Lab:**

Tel: 886-2-26052180

Fax: 886-2-26051924

**Hsin Chu EMC/RF Lab:**

Tel: 886-3-5935343

Fax: 886-3-5935342

**Hwa Ya EMC/RF/Safety Telecom Lab:**

Tel: 886-3-3183232

Fax: 886-3-3270892

**Email:** [service.adt@tw.bureauveritas.com](mailto:service.adt@tw.bureauveritas.com)

**Web Site:** [www.bureauveritas-adt.com](http://www.bureauveritas-adt.com)

The address and road map of all our labs can be found in our web site also.



A D T

## 8. APPENDIX A – MODIFICATIONS RECORDERS FOR ENGINEERING CHANGES TO THE EUT BY THE LAB

No any modifications are made to the EUT by the lab during the test.

---END---