



FCC TEST REPORT (15.407)

REPORT NO.: RF131106C22-1
MODEL NO.: EAP210/OWL530; IWF5210
(Refer to item 3.1 for more details)
FCC ID: VZ9130002
RECEIVED: Nov. 06, 2013
TESTED: Dec. 10, 2013 ~Jun. 11, 2014
ISSUED: Jun. 16, 2014

APPLICANT: 4IPNET, INC.

ADDRESS: 3F-3, No. 369, Fusing N. Rd., Taipei 105,
Taiwan,R.O.C.

ISSUED BY: Bureau Veritas Consumer Products Services
(H.K.) Ltd., Taoyuan Branch

LAB ADDRESS: No. 47, 14th Ling, Chia Pau Vil., Lin Kou Dist.,
New Taipei City, Taiwan (R.O.C)

TEST LOCATION: No. 19, Hwa Ya 2nd Rd, Wen Hwa Tsuen, Kwei
Shan Hsiang, Taoyuan Hsien 333, Taiwan, R.O.C.

This report should not be used by the client to claim product certification, approval, or endorsement by TAF or any government agencies.



This report is for your exclusive use. Any copying or replication of this report to or for any other person or entity, or use of our name or trademark, is permitted only with our prior written permission. This report sets forth our findings solely with respect to the test samples identified herein. The results set forth in this report are not indicative or representative of the quality or characteristics of the lot from which a test sample was taken or any similar or identical product unless specifically and expressly noted. Our report includes all of the tests requested by you and the results thereof based upon the information that you provided to us. You have 60 days from date of issuance of this report to notify us of any material error or omission caused by our negligence, provided, however, that such notice shall be in writing and shall specifically address the issue you wish to raise. A failure to raise such issue within the prescribed time shall constitute your unqualified acceptance of the completeness of this report, the tests conducted and the correctness of the report contents. Unless specific mention, the uncertainty of measurement has been explicitly taken into account to declare the compliance or non-compliance to the specification

TABLE OF CONTENTS

RELEASE CONTROL RECORD.....	4
1. CERTIFICATION.....	5
2. SUMMARY OF TEST RESULTS.....	6
2.1 MEASUREMENT uncertainty.....	6
3. GENERAL INFORMATION.....	7
3.1 GENERAL DESCRIPTION OF EUT	7
3.2 DESCRIPTION OF TEST MODES	9
3.2.1 Test Mode Applicability and tested channel detail	10
3.3 DESCRIPTION OF SUPPORT UNITS	12
3.3.1 CONFIGURATION OF SYSTEM UNDER TEST	12
3.4 Duty cycle of test signal	14
3.5 GENERAL DESCRIPTION OF APPLIED STANDARDS	15
4. TEST TYPES AND RESULTS.....	16
4.1 Radiated Emission AND BANDEDGE Measurement	16
4.1.1 LIMITS OF RADIATED EMISSION AND BANDEDGE MEASUREMENT	16
4.1.2 LIMITS OF UNWANTED EMISSION OUT OF THE RESTRICTED BANDS	16
4.1.3 TEST INSTRUMENTS	17
4.1.4 TEST PROCEDURES	18
4.1.5 DEVIATION FROM TEST STANDARD	18
4.1.6 TEST SETUP.....	19
4.1.7 EUT OPERATING CONDITION	19
4.1.8 Test RESULTS.....	20
4.2 CONDUCTED EMISSION MEASUREMENT	49
4.2.1 LIMITS OF CONDUCTED EMISSION MEASUREMENT	49
4.2.2 TEST INSTRUMENTS	49
4.2.3 TEST PROCEDURES	50
4.2.4 DEVIATION FROM TEST STANDARD	50
4.2.5 TEST SETUP.....	50
4.2.6 EUT OPERATING CONDITIONS.....	50
4.2.7 TEST RESULTS	51
4.3 Peak transmit power MEASUREMENT	57
4.3.1 LIMITS OF PEAK TRANSMIT POWER MEASUREMENT	57
4.3.2 TEST SETUP.....	57
4.3.3 TEST INSTRUMENTS	57
4.3.4 TEST PROCEDURE	58
4.3.5 DEVIATION FROM TEST STANDARD	58
4.3.6 EUT OPERATING CONDITIONS.....	58
4.3.7 TEST RESULTS	59
4.4 PEAK power spectral density measurement	62
4.4.1 LIMITS OF PEAK POWER SPECTRAL DENSITY MEASUREMENT	62
4.4.2 TEST SETUP.....	62
4.4.3 TEST INSTRUMENTS	62
4.4.4 TEST PROCEDURES	62
4.4.5 DEVIATION FROM TEST STANDARD	62
4.4.6 EUT OPERATING CONDITIONS.....	62
4.4.7 TEST RESULTS	63
4.5 Peak power EXCURSION MEASUREMENT	65



4.5.1	LIMITS OF PEAK POWER EXCURSION MEASUREMENT	65
4.5.2	TEST SETUP.....	65
4.5.3	TEST INSTRUMENTS	65
4.5.4	TEST PROCEDURE	65
4.5.5	DEVIATION FROM TEST STANDARD	65
4.5.6	EUT OPERATING CONDITIONS.....	65
4.5.7	TEST RESULTS	66
4.6	FREQUENCY STABILITY.....	69
4.6.1	LIMITS OF FREQUENCY STABILITY MEASUREMENT	69
4.6.2	TEST SETUP.....	69
4.6.3	TEST INSTRUMENTS	69
4.6.4	TEST PROCEDURE	70
4.6.5	DEVIATION FROM TEST STANDARD	70
4.6.6	EUT OPERATING CONDITION	70
4.6.7	TEST RESULTS	71
5.	PHOTOGRAPHS OF THE TEST CONFIGURATION.....	72
6.	INFORMATION ON THE TESTING LABORATORIES.....	73
7.	APPENDIX A - MODIFICATIONS RECORDERS FOR ENGINEERING CHANGES TO THE EUT BY THE LAB.....	74



A D T

RELEASE CONTROL RECORD

ISSUE NO.	REASON FOR CHANGE	DATE ISSUED
RF131106C22-1	Original release	Jun. 16, 2014



1. CERTIFICATION

PRODUCT: Enterprise Access Point
MODEL NO.: EAP210/OWL530; IWF5210
BRAND: 4ipnet ; NEXCOM
APPLICANT: 4IPNET, INC.
TESTED: Dec. 10, 2013 ~Jun. 11, 2014
TEST SAMPLE: Identical Prototype
STANDARDS: **FCC Part 15, Subpart E (Section 15.407)**
ANSI C63.10-2009

The above equipment has been tested by **Bureau Veritas Consumer Products Services (H.K.) Ltd., Taoyuan Branch**, and found compliance with the requirement of the above standards. The test record, data evaluation & Equipment Under Test (EUT) configurations represented herein are true and accurate accounts of the measurements of the sample's EMC characteristics under the conditions specified in this report.

PREPARED BY : Gina Liu , **DATE** : Jun. 16, 2014
Gina Liu / Specialist

APPROVED BY : Sam Chen , **DATE** : Jun. 16, 2014
Sam Chen / Senior Project Engineer

2. SUMMARY OF TEST RESULTS

The EUT has been tested according to the following specifications:

APPLIED STANDARD: FCC PART 15, SUBPART E (SECTION 15.407)			
STANDARD SECTION	TEST TYPE	RESULT	REMARK
15.407(b)(6)	AC Power Conducted Emission	PASS	Meet the requirement of limit. Minimum passing margin is -3.45dB at 0.16172MHz.
15.407(b/1/2/3) (b)(6)	Spurious Emissions	PASS	Meet the requirement of limit. Minimum passing margin is -3.71dB at 47.82MHz.
15.407(a/1/2)	Peak Transmit Power	PASS	Meet the requirement of limit.
15.407(a)(6)	Peak Power Excursion	PASS	Meet the requirement of limit.
15.407(a/1/2)	Peak Power Spectral Density	PASS	Meet the requirement of limit.
15.407(g)	Frequency Stability	PASS	Meet the requirement of limit.
15.203	Antenna Requirement	PASS	Antenna connector is N-Type. (The device is professionally installed) Antenna connector is RSMA not a standard connector.

2.1 MEASUREMENT UNCERTAINTY

Where relevant, the following measurement uncertainty levels have been estimated for tests performed on the EUT as specified in CISPR 16-4-2:

MEASUREMENT	FREQUENCY	UNCERTAINTY
Conducted emissions	9kHz~30MHz	2.44 dB
Radiated emissions	30MHz ~ 200MHz	2.93 dB
	200MHz ~1000MHz	2.95 dB
	1GHz ~ 18GHz	2.26 dB
	18GHz ~ 40GHz	1.94 dB

This uncertainty represents an expanded uncertainty expressed at approximately the 95% confidence level using a coverage factor of $k = 2$.

3. GENERAL INFORMATION

3.1 GENERAL DESCRIPTION OF EUT

EUT	Enterprise Access Point
MODEL NO.	EAP210/OWL530; IWF5210 (Refer to Note as below)
POWER SUPPLY	12Vdc (adapter)
MODULATION TYPE	64QAM, 16QAM, QPSK, BPSK
MODULATION TECHNOLOGY	OFDM
TRANSFER RATE	802.11a: 54.0/ 48.0/ 36.0/ 24.0/ 18.0/ 12.0/ 9.0/ 6.0Mbps 802.11n: up to MCS7
OPERATING FREQUENCY	5180 ~ 5240MHz
NUMBER OF CHANNEL	5180 ~ 5240MHz: 4 for 802.11a, 802.11n (20MHz) 2 for 802.11n (40MHz)
OUTPUT POWER	17.10mW for 5180 ~ 5240MHz
ANTENNA TYPE	Dipole antenna with 5dBi gain
ANTENNA CONNECTOR	SMA and N-type
DATA CABLE	Refer to Note as below
I/O PORTS	Refer to user's manual
ACCESSORY DEVICES	Refer to Note as below

NOTE:

- The detail information of model names and the differences of three samples are as below.

Sample	Model	Difference	Power Supply
A	EAP210	SMA connectors	from Adapter or POE
B	OWL530	N-type connectors	from POE only
C	IWF5210		

* Sample B and Sample C are electrically identical, different model names and brand name. The model of 'OWL530' was chosen for final test.

- The EUT contains following accessory devices.

ITEM	BRAND	MODEL	SPECIFICATION
Adapter 1 (for EAP210)	OEM	ADS0271-W 120200	I/P: 100-240Vac, 600mA O/P: 12Vdc, 2000mA Cpu pins
Adapter 2 (for EAP210)	Ktec	KSASB0241200200D5	I/P: 100-240Vac, 600mA O/P: 12Vdc, 2000mA
RS 232 Cable (for EAP210)	E-FLY	DB9F-DB9F-050	--
Earth Wire (for OWL530)	N/A	N/A	--
U-Type Bolts (for OWL530)	N/A	N/A	--
Dipole Antenna 1 (for EAP210)	N/A	AN2450-9221RS	--
Dipole Antenna 2 (for EAP210)	N/A	AN2450-5003BRS	--

*The Dipole Antenna 1 and Dipole Antenna 2 are different in the appearance only. Therefore, Dipole Antenna 1 was chosen for final testing.



A D T

3. The EUT incorporates a MIMO function. Physically, the EUT provides 2 completed transmitters and 2 receivers.

MODULATION MODE	TX FUNCTION	Antenna (dBi)	
		1TX	2TX
802.11a	1TX	5.0	-
802.11n (20MHz)	1TX, 2TX	5.0	8.0
802.11n (40MHz)	1TX, 2TX	5.0	8.0

4. The above EUT information is declared by the manufacturer and for more detailed features description, please refer to the manufacturer's specifications or User's Manual.

3.2 DESCRIPTION OF TEST MODES

FOR 5180 ~ 5240MHz

4 channels are provided for 802.11a, 802.11n (20MHz):

CHANNEL	FREQUENCY	CHANNEL	FREQUENCY
36	5180 MHz	44	5220 MHz
40	5200 MHz	48	5240 MHz

2 channels are provided for 802.11n (40MHz):

CHANNEL	FREQUENCY	CHANNEL	FREQUENCY
38	5190 MHz	46	5230 MHz

3.2.1 TEST MODE APPLICABILITY AND TESTED CHANNEL DETAIL

EUT CONFIGURE MODE	APPLICABLE TO				DESCRIPTION
	RE \geq 1G	RE<1G	PLC	APCM	
A	√	√	√	√	Sample A with 1TX
B	√	-	-	√	Sample A with 2TX
C	√	√	√	-	Sample B with 1TX
D	√	-	-	-	Sample B with 2TX

Where **RE \geq 1G**: Radiated Emission above 1GHz

RE<1G: Radiated Emission below 1GHz

PLC: Power Line Conducted Emission

APCM: Antenna Port Conducted Measurement

NOTE: The EUT had been pre-tested on the positioned of each 3 axis. The worst case was found when positioned on **X-plane**.

RADIATED EMISSION TEST (ABOVE 1GHz):

- Pre-Scan has been conducted to determine the worst-case mode from all possible combinations between available modulations, data rates and antenna ports (if EUT with antenna diversity architecture).
- Following channel(s) was (were) selected for the final test as listed below.

EUT CONFIGURE MODE	MODE	FREQ. BAND (MHz)	AVAILABLE CHANNEL	TESTED CHANNEL	MODULATION TECHNOLOGY	MODULATION TYPE	DATA RATE (Mbps)
A, C	802.11a	5180-5240	36 to 48	36, 44, 48	OFDM	BPSK	6.0
A, B, C, D	802.11n (20MHz)		36 to 48	36, 44, 48	OFDM	BPSK	MCS0
A, B, C, D	802.11n (40MHz)		38 to 46	38, 46	OFDM	BPSK	MCS0

RADIATED EMISSION TEST (BELOW 1GHz):

- Pre-Scan has been conducted to determine the worst-case mode from all possible combinations between available modulations, data rates and antenna ports (if EUT with antenna diversity architecture).
- Following channel(s) was (were) selected for the final test as listed below.

EUT CONFIGURE MODE	MODE	FREQ. BAND (MHz)	AVAILABLE CHANNEL	TESTED CHANNEL	MODULATION TECHNOLOGY	MODULATION TYPE	DATA RATE (Mbps)
A, C	802.11n (20MHz)	5180-5240	36 to 48	48	OFDM	BPSK	MCS0

POWER LINE CONDUCTED EMISSION TEST:

- Pre-Scan has been conducted to determine the worst-case mode from all possible combinations between available modulations, data rates and antenna ports (if EUT with antenna diversity architecture).
- Following channel(s) was (were) selected for the final test as listed below.

EUT CONFIGURE MODE	MODE	FREQ. BAND (MHz)	AVAILABLE CHANNEL	TESTED CHANNEL	MODULATION TECHNOLOGY	MODULATION TYPE	DATA RATE (Mbps)
A, C	802.11n (20MHz)	5180-5240	36 to 48	48	OFDM	BPSK	MCS0

BANDEDGE MEASUREMENT:

- Pre-Scan has been conducted to determine the worst-case mode from all possible combinations between available modulations, data rates and antenna ports (if EUT with antenna diversity architecture).
- Following channel(s) was (were) selected for the final test as listed below.

EUT CONFIGURE MODE	MODE	FREQ. BAND (MHz)	AVAILABLE CHANNEL	TESTED CHANNEL	MODULATION TECHNOLOGY	MODULATION TYPE	DATA RATE (Mbps)
A	802.11a	5180-5240	36 to 48	36, 48	OFDM	BPSK	6.0
A, B	802.11n (20MHz)		36 to 48	36, 48	OFDM	BPSK	MCS0
A, B	802.11n (40MHz)		38 to 46	38, 46	OFDM	BPSK	MCS0

ANTENNA PORT CONDUCTED MEASUREMENT:

- This item includes all test value of each mode, but only includes spectrum plot of worst value of each mode.
- Pre-Scan has been conducted to determine the worst-case mode from all possible combinations between available modulations, data rates and antenna ports (if EUT with antenna diversity architecture).
- Following channel(s) was (were) selected for the final test as listed below.

EUT CONFIGURE MODE	MODE	FREQ. BAND (MHz)	AVAILABLE CHANNEL	TESTED CHANNEL	MODULATION TECHNOLOGY	MODULATION TYPE	DATA RATE (Mbps)
A	802.11a	5180-5240	36 to 48	36, 44, 48	OFDM	BPSK	6.0
A, B	802.11n (20MHz)		36 to 48	36, 44, 48	OFDM	BPSK	MCS0
A, B	802.11n (40MHz)		38 to 46	38, 46	OFDM	BPSK	MCS0

TEST CONDITION:

APPLICABLE TO	ENVIRONMENTAL CONDITIONS	INPUT POWER	TESTED BY
RE≥1G	25deg. C, 65%RH	120Vac, 60Hz	Kay Wu
RE<1G	25deg. C, 65%RH	120Vac, 60Hz	Kay Wu
PLC	25deg. C, 65%RH	120Vac, 60Hz	Johnson Liao
APCM	25deg. C, 65%RH	120Vac, 60Hz	Demon Lin

3.3 DESCRIPTION OF SUPPORT UNITS

The EUT has been tested as an independent unit together with other necessary accessories or support units. The following support units or accessories were used to form a representative test configuration during the tests.

NO.	PRODUCT	BRAND	MODEL NO.	SERIAL NO.	FCC ID
1	Notebook	DELL	PP02X	W4TYK9CQCJ3K3K CBRXTRFWYRB	QDS-BRCM1005-D

NO.	SIGNAL CABLE DESCRIPTION OF THE ABOVE SUPPORT UNITS
1	NA

NOTE: 1. All power cords of the above support units are non shielded (1.8m).

3.3.1 CONFIGURATION OF SYSTEM UNDER TEST

For Sample A

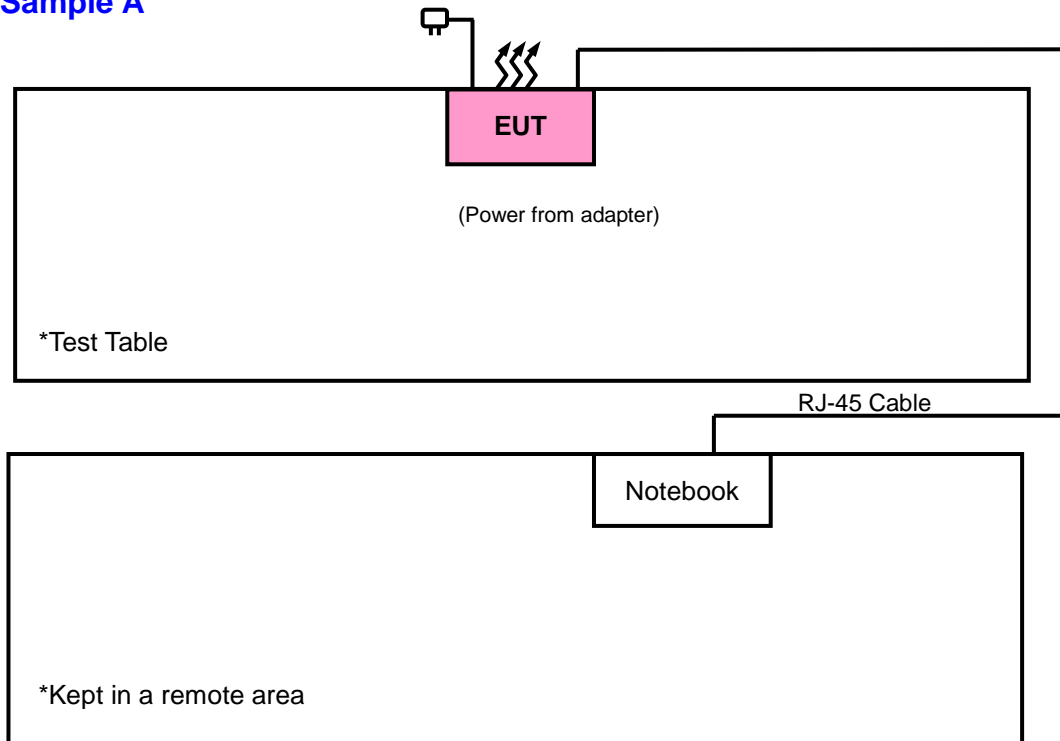

For Sample A & B

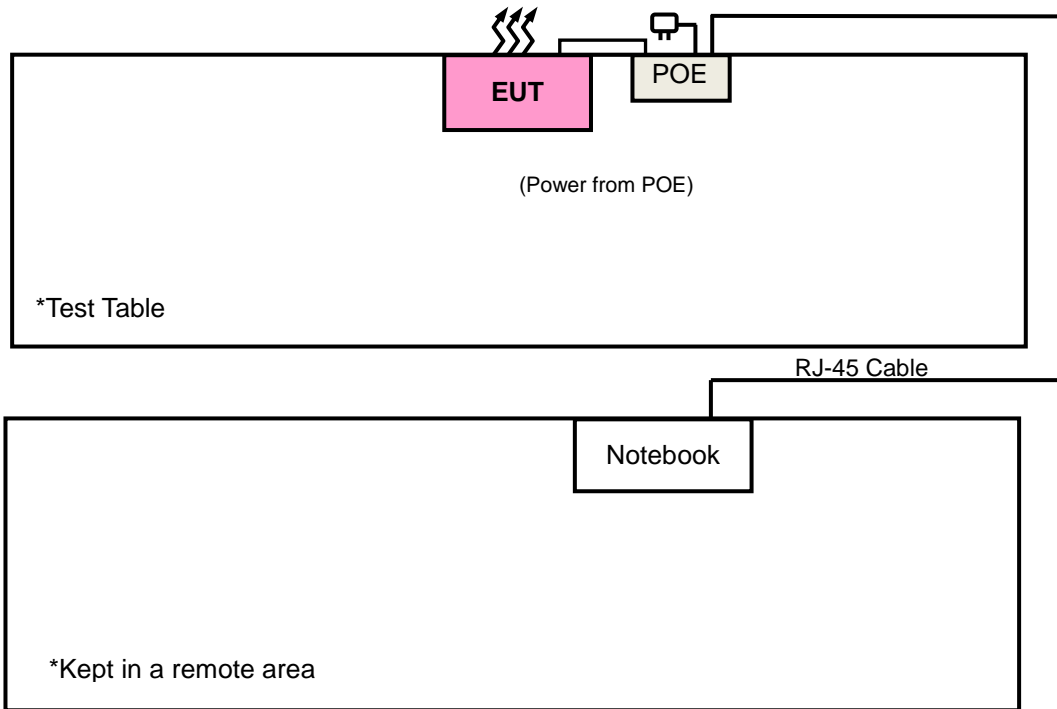

3.4 DUTY CYCLE OF TEST SIGNAL

MODE A

If duty cycle is < 98%, duty factor shall be considered.

802.11a: Duty cycle = $1.354/1.418 = 0.954$, Duty factor = $10 * \log(1/0.954) = 0.20$

802.11n (20MHz): Duty cycle = $1.258/1.330 = 0.945$, Duty factor = $10 * \log(1/0.945) = 0.24$

802.11n (40MHz): Duty cycle = $601/665 = 0.903$, Duty factor = $10 * \log(1/0.903) = 0.44$



MODE B

If duty cycle is < 98%, duty factor shall be considered.

802.11n (20MHz): Duty cycle = $652/711 = 0.917$, Duty factor = $10 * \log(1/0.917) = 0.38$

802.11n (40MHz): Duty cycle = $340/375 = 0.906$, Duty factor = $10 * \log(1/0.906) = 0.43$

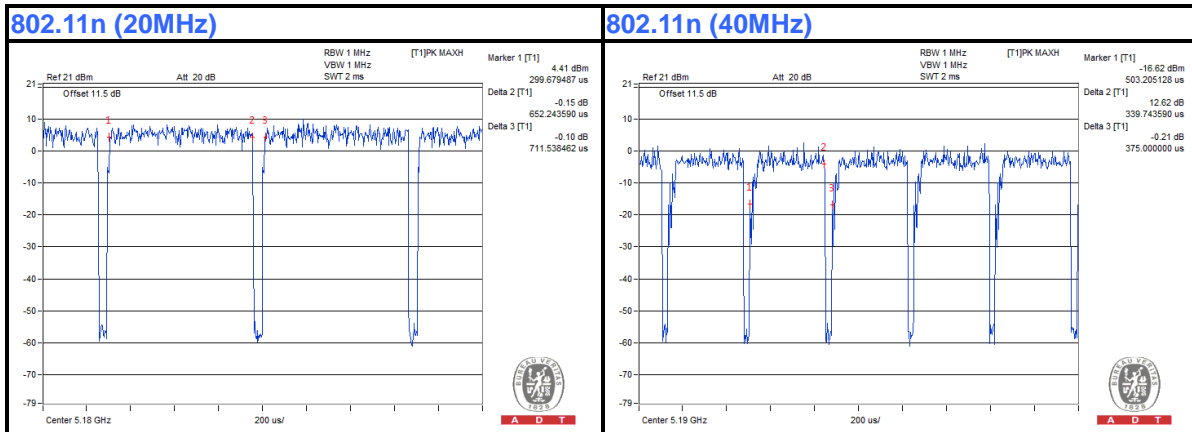

3.5 GENERAL DESCRIPTION OF APPLIED STANDARDS

The EUT is a RF Product. According to the specifications of the manufacturer, it must comply with the requirements of the following standards:

FCC Part 15, Subpart E (15.407)

ANSI C63.10-2009

KDB 789033 D01 General UNII Test Procedures v01r02

KDB 662911 D01 Multiple Transmitter Output v01 r02

All test items have been performed and recorded as per the above standards.

NOTE: The EUT is also considered as a kind of computer peripheral, because the connection to computer is necessary for typical use. It has been verified to comply with the requirements of FCC Part 15, Subpart B, Class B (DoC). The test report has been issued separately.

4. TEST TYPES AND RESULTS

4.1 RADIATED EMISSION AND BANDEDGE MEASUREMENT

4.1.1 LIMITS OF RADIATED EMISSION AND BANDEDGE MEASUREMENT

Radiated emissions which fall in the restricted bands must comply with the radiated emission limits specified as below table:

FREQUENCIES (MHz)	FIELD STRENGTH (microvolts/meter)	MEASUREMENT DISTANCE (meters)
0.009 ~ 0.490	2400/F(kHz)	300
0.490 ~ 1.705	24000/F(kHz)	30
1.705 ~ 30.0	30	30
30 ~ 88	100	3
88 ~ 216	150	3
216 ~ 960	200	3
Above 960	500	3

NOTE:

1. The lower limit shall apply at the transition frequencies.
2. Emission level (dBuV/m) = 20 log Emission level (uV/m).
3. For frequencies above 1000MHz, the field strength limits are based on average detector, however, the peak field strength of any emission shall not exceed the maximum permitted average limits, specified above by more than 20dB under any condition of modulation.

4.1.2 LIMITS OF UNWANTED EMISSION OUT OF THE RESTRICTED BANDS

APPLICABLE TO	LIMIT	
√	FIELD STRENGTH AT 3m (dBμV/m)	
	PK	AV
	74	54
	EIRP LIMIT (dBm)	EQUIVALENT FIELD STRENGTH AT 3m (dBμV/m)
	PK	PK
	-27	68.3

NOTE: The following formula is used to convert the equipment isotropic radiated power (eirp) to field strength:

$$E = \frac{1000000\sqrt{30P}}{3} \mu\text{V/m, where P is the eirp (Watts).}$$



4.1.3 TEST INSTRUMENTS

DESCRIPTION & MANUFACTURER	MODEL NO.	SERIAL NO.	DATE OF CALIBRATION	DUE DATE OF CALIBRATION
Test Receiver ROHDE & SCHWARZ	ESCI	100744	Apr. 15, 2013	Apr. 14, 2014
Test Receiver ROHDE & SCHWARZ	ESCI	100744	Apr. 15, 2014	Apr. 14, 2015
Spectrum Analyzer ROHDE & SCHWARZ	FSU43	101261	Dec. 21, 2013	Dec. 20, 2014
BILOG Antenna SCHWARZBECK	VULB9168	9168-472	Mar. 25, 2013	Mar. 24, 2014
BILOG Antenna SCHWARZBECK	VULB9168	9168-472	Feb. 27, 2014	Feb. 26, 2015
HORN Antenna SCHWARZBECK	BBHA 9120 D	9120D-563	Nov. 01, 2013	Oct. 31, 2014
HORN Antenna SCHWARZBECK	BBHA 9170	9170-480	Dec. 18, 2013	Dec. 17, 2014
Loop Antenna	HFH2-Z2	100070	Jan. 31, 2012	Jan. 30, 2014
Loop Antenna	HFH2-Z2	100070	Mar. 06, 2014	Mar. 05, 2016
Preamplifier EMCI	EMC 012645	980115	Dec. 26, 2013	Dec. 25, 2014
Preamplifier EMCI	EMC 184045	980116	Jan. 13, 2014	Jan. 12, 2015
Preamplifier EMCI	EMC 330H	980112	Dec. 27, 2013	Dec. 26, 2014
RF signal cable HUBER+SUHNNER	SUCOFLEX 104	309219/4	Oct. 18, 2013	Oct. 17, 2014
RF signal cable HUBER+SUHNNER	SUCOFLEX 104	250130/4	Oct. 18, 2013	Oct. 17, 2014
RF signal cable Worken	RG-213	NA	Nov. 07, 2013	Nov. 06, 2014
Software	E3 6.120103	NA	NA	NA
Antenna Tower MF	MFA-440H	NA	NA	NA
Turn Table MF	MFT-201SS	NA	NA	NA
Antenna Tower & Turn Table Controller MF	MF-7802	NA	NA	NA
Power Meter	ML2495A	1232002	Aug. 23, 2013	Aug. 22, 2014
Power Sensor	MA2411B	1207325	Aug. 23, 2013	Aug. 22, 2014

- NOTE:**
1. The calibration interval of the above test instruments is 12 months and the calibrations are traceable to NML/ROC and NIST/USA.
 2. The calibration interval of the loop antenna is 24 months and the calibrations are traceable to NML/ROC and NIST/USA.
 3. The test was performed in HwaYa Chamber 10.
 4. The horn antenna and HP preamplifier (model: 8449B) are used only for the measurement of emission frequency above 1GHz if tested.
 5. The FCC Site Registration No. is 690701.
 6. The IC Site Registration No. is IC 7450F-10.

4.1.4 TEST PROCEDURES

- a. The EUT was placed on the top of a rotating table 0.8 meters above the ground at a 3 meter semi-anechoic chamber. The table was rotated 360 degrees to determine the position of the highest radiation.
- b. The EUT was set 3 meters away from the interference-receiving antenna, which was mounted on the top of a variable-height antenna tower.
- c. The antenna is a broadband antenna, and its height is varied from one meter to four meters above the ground to determine the maximum value of the field strength. Both horizontal and vertical polarizations of the antenna are set to make the measurement.
- d. For each suspected emission, the EUT was arranged to its worst case and then the antenna was tuned to heights from 1 meter to 4 meters and the rotatable table was turned from 0 degrees to 360 degrees to find the maximum reading.
- e. The test-receiver system was set to Peak Detect Function and Specified Bandwidth with Maximum Hold Mode.
- f. If the emission level of the EUT in peak mode was 10dB lower than the limit specified, then testing could be stopped and the peak values of the EUT would be reported. Otherwise the emissions that did not have 10dB margin would be re-tested one by one using peak, quasi-peak or average method as specified and then reported in a data sheet.

NOTE:

1. The resolution bandwidth and video bandwidth of test receiver/spectrum analyzer is 120kHz for Peak detection (PK) and Quasi-peak detection (QP) at frequency below 1GHz.
2. The resolution bandwidth of test receiver/spectrum analyzer is 1MHz and video bandwidth is 3MHz for Peak detection at frequency above 1GHz.
3. The resolution bandwidth of test receiver/spectrum analyzer is 1MHz and the video bandwidth is 1kHz for Average detection (AV) at frequency above 1GHz.
4. All modes of operation were investigated and the worst-case emissions are reported.

4.1.5 DEVIATION FROM TEST STANDARD

No deviation.

4.1.6 TEST SETUP

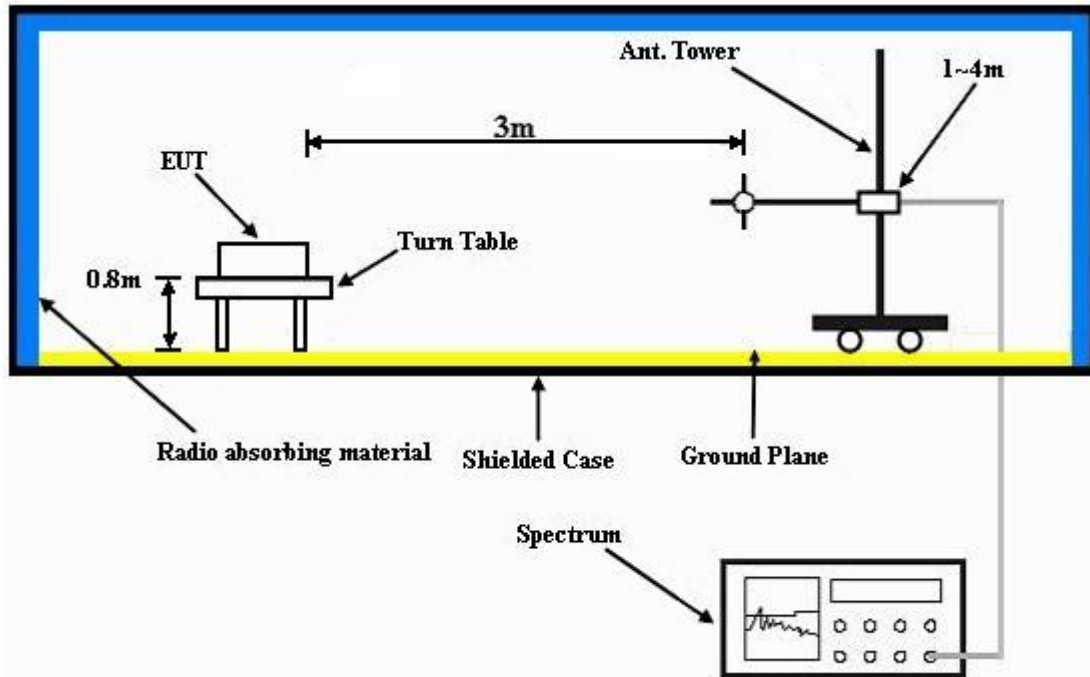

For the actual test configuration, please refer to the attached file (Test Setup Photo).

4.1.7 EUT OPERATING CONDITION

- a. Placed the EUT on a testing table.
- b. Use the software to control the EUT under transmission condition continuously at specific channel frequency.

4.1.8 TEST RESULTS

MODE A

ABOVE 1GHz DATA: 802.11a

EUT TEST CONDITION		MEASUREMENT DETAIL	
CHANNEL	Channel 36	FREQUENCY RANGE	1GHz ~ 40GHz
INPUT POWER (SYSTEM)	120Vac, 60 Hz	DETECTOR FUNCTION	Peak (PK) Average (AV)
ENVIRONMENTAL CONDITIONS	25deg. C, 65%RH	TESTED BY	Kay Wu

ANTENNA POLARITY & TEST DISTANCE: HORIZONTAL AT 3 M										
FREQ. (MHz)	EMISSION LEVEL (dBuV/m)	READ LEVEL (dBuV)	LIMIT (dBuV/m)	MARGIN (dB)	ANTENNA FACTOR (dB/m)	CABLE LOSS (dB)	PREAMP FACTOR (dB)	ANTENNA HEIGHT (cm)	TABLE ANGLE (Degree)	REMARK
5088	44.19	35.67	54	-9.81	34.43	8.07	33.98	160	152	Average
5088	59.33	50.81	74	-14.67	34.43	8.07	33.98	160	152	Peak
5180	92.49	83.86			34.47	8.16	34	160	152	Average
5180	99.16	90.53			34.47	8.16	34	160	152	Peak
5396	45.47	36.57	54	-8.53	34.5	8.44	34.04	160	152	Average
5396	60.31	51.41	74	-13.69	34.5	8.44	34.04	160	152	Peak
ANTENNA POLARITY & TEST DISTANCE: VERTICAL AT 3 M										
FREQ. (MHz)	EMISSION LEVEL (dBuV/m)	READ LEVEL (dBuV)	LIMIT (dBuV/m)	MARGIN (dB)	ANTENNA FACTOR (dB/m)	CABLE LOSS (dB)	PREAMP FACTOR (dB)	ANTENNA HEIGHT (cm)	TABLE ANGLE (Degree)	REMARK
5108	45.11	36.55	54	-8.89	34.45	8.1	33.99	161	0	Average
5108	59.35	50.79	74	-14.65	34.45	8.1	33.99	161	0	Peak
5180	98.62	89.99			34.47	8.16	34	161	0	Average
5180	105.89	97.26			34.47	8.16	34	161	0	Peak
5452	45.58	36.62	54	-8.42	34.5	8.51	34.05	161	0	Average
5452	60.48	51.52	74	-13.52	34.5	8.51	34.05	161	0	Peak

REMARKS:

- Emission Level = Read Level + Antenna Factor + Cable Loss - Preamp Factor
Margin value = Emission level – Limit value
- 5180MHz: Fundamental frequency.



A D T

EUT TEST CONDITION		MEASUREMENT DETAIL	
CHANNEL	Channel 44	FREQUENCY RANGE	1GHz ~ 40GHz
INPUT POWER (SYSTEM)	120Vac, 60 Hz	DETECTOR FUNCTION	Peak (PK) Average (AV)
ENVIRONMENTAL CONDITIONS	25deg. C, 65%RH	TESTED BY	Kay Wu

ANTENNA POLARITY & TEST DISTANCE: HORIZONTAL AT 3 M										
FREQ. (MHz)	EMISSION LEVEL (dBuV/m)	READ LEVEL (dBuV)	LIMIT (dBuV/m)	MARGIN (dB)	ANTENNA FACTOR (dB/m)	CABLE LOSS (dB)	PREAMP FACTOR (dB)	ANTENNA HEIGHT (cm)	TABLE ANGLE (Degree)	REMARK
5022	44.91	36.5	54	-9.09	34.41	7.97	33.97	161	150	Average
5022	59.78	51.37	74	-14.22	34.41	7.97	33.97	161	150	Peak
5220	93.2	84.49			34.49	8.22	34	161	150	Average
5220	100.49	91.78			34.49	8.22	34	161	150	Peak
5382	44.5	35.63	54	-9.5	34.5	8.41	34.04	161	150	Average
5382	59.51	50.64	74	-14.49	34.5	8.41	34.04	161	150	Peak
ANTENNA POLARITY & TEST DISTANCE: VERTICAL AT 3 M										
FREQ. (MHz)	EMISSION LEVEL (dBuV/m)	READ LEVEL (dBuV)	LIMIT (dBuV/m)	MARGIN (dB)	ANTENNA FACTOR (dB/m)	CABLE LOSS (dB)	PREAMP FACTOR (dB)	ANTENNA HEIGHT (cm)	TABLE ANGLE (Degree)	REMARK
5146	46.11	37.52	54	-7.89	34.46	8.13	34	161	0	Average
5146	60.77	52.18	74	-13.23	34.46	8.13	34	161	0	Peak
5220	98.57	89.86			34.49	8.22	34	161	0	Average
5220	105.49	96.78			34.49	8.22	34	161	0	Peak
5428	45.21	36.27	54	-8.79	34.5	8.48	34.04	161	0	Average
5428	60.79	51.85	74	-13.21	34.5	8.48	34.04	161	0	Peak

REMARKS:

- Emission Level = Read Level + Antenna Factor + Cable Loss - Preamp Factor
Margin value = Emission level – Limit value
- 5220MHz: Fundamental frequency.



EUT TEST CONDITION		MEASUREMENT DETAIL	
CHANNEL	Channel 48	FREQUENCY RANGE	1GHz ~ 40GHz
INPUT POWER (SYSTEM)	120Vac, 60 Hz	DETECTOR FUNCTION	Peak (PK) Average (AV)
ENVIRONMENTAL CONDITIONS	25deg. C, 65%RH	TESTED BY	Kay Wu

ANTENNA POLARITY & TEST DISTANCE: HORIZONTAL AT 3 M										
FREQ. (MHz)	EMISSION LEVEL (dBuV/m)	READ LEVEL (dBuV)	LIMIT (dBuV/m)	MARGIN (dB)	ANTENNA FACTOR (dB/m)	CABLE LOSS (dB)	PREAMP FACTOR (dB)	ANTENNA HEIGHT (cm)	TABLE ANGLE (Degree)	REMARK
5076	43.33	34.85	54	-10.67	34.43	8.03	33.98	164	150	Average
5076	59.22	50.74	74	-14.78	34.43	8.03	33.98	164	150	Peak
5240	93.44	84.7			34.49	8.26	34.01	164	150	Average
5240	100.58	91.84			34.49	8.26	34.01	164	150	Peak
5458	44.53	35.57	54	-9.47	34.5	8.51	34.05	164	150	Average
5458	60.59	51.63	74	-13.41	34.5	8.51	34.05	164	150	Peak
ANTENNA POLARITY & TEST DISTANCE: VERTICAL AT 3 M										
FREQ. (MHz)	EMISSION LEVEL (dBuV/m)	READ LEVEL (dBuV)	LIMIT (dBuV/m)	MARGIN (dB)	ANTENNA FACTOR (dB/m)	CABLE LOSS (dB)	PREAMP FACTOR (dB)	ANTENNA HEIGHT (cm)	TABLE ANGLE (Degree)	REMARK
5136	43.81	35.22	54	-10.19	34.45	8.13	33.99	159	0	Average
5136	60.54	51.95	74	-13.46	34.45	8.13	33.99	159	0	Peak
5240	98.33	89.59			34.49	8.26	34.01	159	0	Average
5240	106.36	97.62			34.49	8.26	34.01	159	0	Peak
5356	44.14	35.29	54	-9.86	34.5	8.38	34.03	159	0	Average
5356	60.57	51.72	74	-13.43	34.5	8.38	34.03	159	0	Peak

REMARKS:

- Emission Level = Read Level + Antenna Factor + Cable Loss - Preamp Factor
Margin value = Emission level – Limit value
- 5240MHz: Fundamental frequency.



802.11n (20MHz)

EUT TEST CONDITION		MEASUREMENT DETAIL	
CHANNEL	Channel 36	FREQUENCY RANGE	1GHz ~ 40GHz
INPUT POWER (SYSTEM)	120Vac, 60 Hz	DETECTOR FUNCTION	Peak (PK) Average (AV)
ENVIRONMENTAL CONDITIONS	25deg. C, 65%RH	TESTED BY	Kay Wu

ANTENNA POLARITY & TEST DISTANCE: HORIZONTAL AT 3 M										
FREQ. (MHz)	EMISSION LEVEL (dBuV/m)	READ LEVEL (dBuV)	LIMIT (dBuV/m)	MARGIN (dB)	ANTENNA FACTOR (dB/m)	CABLE LOSS (dB)	PREAMP FACTOR (dB)	ANTENNA HEIGHT (cm)	TABLE ANGLE (Degree)	REMARK
5140	44.84	36.25	54	-9.16	34.45	8.13	33.99	165	151	Average
5140	59.35	50.76	74	-14.65	34.45	8.13	33.99	165	151	Peak
5180	92.53	83.9			34.47	8.16	34	165	151	Average
5180	99.8	91.17			34.47	8.16	34	165	151	Peak
5432	44.75	35.81	54	-9.25	34.5	8.48	34.04	165	151	Average
5432	59.55	50.61	74	-14.45	34.5	8.48	34.04	165	151	Peak
ANTENNA POLARITY & TEST DISTANCE: VERTICAL AT 3 M										
FREQ. (MHz)	EMISSION LEVEL (dBuV/m)	READ LEVEL (dBuV)	LIMIT (dBuV/m)	MARGIN (dB)	ANTENNA FACTOR (dB/m)	CABLE LOSS (dB)	PREAMP FACTOR (dB)	ANTENNA HEIGHT (cm)	TABLE ANGLE (Degree)	REMARK
5130	44.81	36.25	54	-9.19	34.45	8.1	33.99	162	0	Average
5130	59.07	50.51	74	-14.93	34.45	8.1	33.99	162	0	Peak
5180	97.49	88.86			34.47	8.16	34	162	0	Average
5180	104.71	96.08			34.47	8.16	34	162	0	Peak
5444	44.23	35.29	54	-9.77	34.5	8.48	34.04	162	0	Average
5444	59	50.06	74	-15	34.5	8.48	34.04	162	0	Peak

REMARKS:

- Emission Level = Read Level + Antenna Factor + Cable Loss - Preamp Factor
Margin value = Emission level – Limit value
- 5180MHz: Fundamental frequency.



A D T

EUT TEST CONDITION		MEASUREMENT DETAIL	
CHANNEL	Channel 44	FREQUENCY RANGE	1GHz ~ 40GHz
INPUT POWER (SYSTEM)	120Vac, 60 Hz	DETECTOR FUNCTION	Peak (PK) Average (AV)
ENVIRONMENTAL CONDITIONS	25deg. C, 65%RH	TESTED BY	Kay Wu

ANTENNA POLARITY & TEST DISTANCE: HORIZONTAL AT 3 M										
FREQ. (MHz)	EMISSION LEVEL (dBuV/m)	READ LEVEL (dBuV)	LIMIT (dBuV/m)	MARGIN (dB)	ANTENNA FACTOR (dB/m)	CABLE LOSS (dB)	PREAMP FACTOR (dB)	ANTENNA HEIGHT (cm)	TABLE ANGLE (Degree)	REMARK
5148	44.11	35.52	54	-9.89	34.46	8.13	34	162	149	Average
5148	59.63	51.04	74	-14.37	34.46	8.13	34	162	149	Peak
5220	92.66	83.95			34.49	8.22	34	162	149	Average
5220	100.81	92.1			34.49	8.22	34	162	149	Peak
5456	44.56	35.6	54	-9.44	34.5	8.51	34.05	162	149	Average
5456	59.47	50.51	74	-14.53	34.5	8.51	34.05	162	149	Peak

ANTENNA POLARITY & TEST DISTANCE: VERTICAL AT 3 M										
FREQ. (MHz)	EMISSION LEVEL (dBuV/m)	READ LEVEL (dBuV)	LIMIT (dBuV/m)	MARGIN (dB)	ANTENNA FACTOR (dB/m)	CABLE LOSS (dB)	PREAMP FACTOR (dB)	ANTENNA HEIGHT (cm)	TABLE ANGLE (Degree)	REMARK
5040	44.95	36.5	54	-9.05	34.42	8	33.97	161	0	Average
5040	59.1	50.65	74	-14.9	34.42	8	33.97	161	0	Peak
5220	97.87	89.16			34.49	8.22	34	161	0	Average
5220	105.16	96.45			34.49	8.22	34	161	0	Peak
5378	44.36	35.49	54	-9.64	34.5	8.41	34.04	161	0	Average
5378	59.19	50.32	74	-14.81	34.5	8.41	34.04	161	0	Peak

REMARKS:

- Emission Level = Read Level + Antenna Factor + Cable Loss - Preamp Factor
Margin value = Emission level – Limit value
- 5220MHz: Fundamental frequency.



EUT TEST CONDITION		MEASUREMENT DETAIL	
CHANNEL	Channel 48	FREQUENCY RANGE	1GHz ~ 40GHz
INPUT POWER (SYSTEM)	120Vac, 60 Hz	DETECTOR FUNCTION	Peak (PK) Average (AV)
ENVIRONMENTAL CONDITIONS	25deg. C, 65%RH	TESTED BY	Kay Wu

ANTENNA POLARITY & TEST DISTANCE: HORIZONTAL AT 3 M										
FREQ. (MHz)	EMISSION LEVEL (dBuV/m)	READ LEVEL (dBuV)	LIMIT (dBuV/m)	MARGIN (dB)	ANTENNA FACTOR (dB/m)	CABLE LOSS (dB)	PREAMP FACTOR (dB)	ANTENNA HEIGHT (cm)	TABLE ANGLE (Degree)	REMARK
5094	43.76	35.24	54	-10.24	34.44	8.07	33.99	175	151	Average
5094	60.13	51.61	74	-13.87	34.44	8.07	33.99	175	151	Peak
5240	94.01	85.27			34.49	8.26	34.01	175	151	Average
5240	100.92	92.18			34.49	8.26	34.01	175	151	Peak
5456	45.45	36.49	54	-8.55	34.5	8.51	34.05	175	151	Average
5456	59.67	50.71	74	-14.33	34.5	8.51	34.05	175	151	Peak

ANTENNA POLARITY & TEST DISTANCE: VERTICAL AT 3 M										
FREQ. (MHz)	EMISSION LEVEL (dBuV/m)	READ LEVEL (dBuV)	LIMIT (dBuV/m)	MARGIN (dB)	ANTENNA FACTOR (dB/m)	CABLE LOSS (dB)	PREAMP FACTOR (dB)	ANTENNA HEIGHT (cm)	TABLE ANGLE (Degree)	REMARK
5116	44.7	36.14	54	-9.3	34.45	8.1	33.99	159	0	Average
5116	60.08	51.52	74	-13.92	34.45	8.1	33.99	159	0	Peak
5240	98.5	89.76			34.49	8.26	34.01	159	0	Average
5240	105.74	97			34.49	8.26	34.01	159	0	Peak
5360	44.45	35.6	54	-9.55	34.5	8.38	34.03	159	0	Average
5360	59.11	50.26	74	-14.89	34.5	8.38	34.03	159	0	Peak

REMARKS:

- Emission Level = Read Level + Antenna Factor + Cable Loss - Preamp Factor
Margin value = Emission level – Limit value
- 5240MHz: Fundamental frequency.

802.11n (40MHz)

EUT TEST CONDITION		MEASUREMENT DETAIL	
CHANNEL	Channel 38	FREQUENCY RANGE	1GHz ~ 40GHz
INPUT POWER (SYSTEM)	120Vac, 60 Hz	DETECTOR FUNCTION	Peak (PK) Average (AV)
ENVIRONMENTAL CONDITIONS	25deg. C, 65%RH	TESTED BY	Harry Hsueh

ANTENNA POLARITY & TEST DISTANCE: HORIZONTAL AT 3 M										
FREQ. (MHz)	EMISSION LEVEL (dBuV/m)	READ LEVEL (dBuV)	LIMIT (dBuV/m)	MARGIN (dB)	ANTENNA FACTOR (dB/m)	CABLE LOSS (dB)	PREAMP FACTOR (dB)	ANTENNA HEIGHT (cm)	TABLE ANGLE (Degree)	REMARK
5076	43.6	35.48	54	-10.4	34.07	8.03	33.98	146	320	Average
5076	56.66	48.54	74	-17.34	34.07	8.03	33.98	146	320	Peak
5190	86.84	78.5			34.15	8.19	34	146	320	Average
5190	93.99	85.65			34.15	8.19	34	146	320	Peak
5454	45.02	36.2	54	-8.98	34.36	8.51	34.05	146	320	Average
5454	58.18	49.36	74	-15.82	34.36	8.51	34.05	146	320	Peak
ANTENNA POLARITY & TEST DISTANCE: VERTICAL AT 3 M										
FREQ. (MHz)	EMISSION LEVEL (dBuV/m)	READ LEVEL (dBuV)	LIMIT (dBuV/m)	MARGIN (dB)	ANTENNA FACTOR (dB/m)	CABLE LOSS (dB)	PREAMP FACTOR (dB)	ANTENNA HEIGHT (cm)	TABLE ANGLE (Degree)	REMARK
5148	45.77	37.52	54	-8.23	34.12	8.13	34	100	6	Average
5148	57.26	49.01	74	-16.74	34.12	8.13	34	100	6	Peak
5190	91.01	82.67			34.15	8.19	34	100	6	Average
5190	98.4	90.06			34.15	8.19	34	100	6	Peak
5400	44.63	35.91	54	-9.37	34.32	8.44	34.04	100	6	Average
5400	57.77	49.05	74	-16.23	34.32	8.44	34.04	100	6	Peak

REMARKS:

- Emission Level = Read Level + Antenna Factor + Cable Loss - Preamp Factor
Margin value = Emission level – Limit value
- 5190MHz: Fundamental frequency.



A D T

EUT TEST CONDITION		MEASUREMENT DETAIL	
CHANNEL	Channel 46	FREQUENCY RANGE	1GHz ~ 40GHz
INPUT POWER (SYSTEM)	120Vac, 60 Hz	DETECTOR FUNCTION	Peak (PK) Average (AV)
ENVIRONMENTAL CONDITIONS	25deg. C, 65%RH	TESTED BY	Kay Wu

ANTENNA POLARITY & TEST DISTANCE: HORIZONTAL AT 3 M										
FREQ. (MHz)	EMISSION LEVEL (dBuV/m)	READ LEVEL (dBuV)	LIMIT (dBuV/m)	MARGIN (dB)	ANTENNA FACTOR (dB/m)	CABLE LOSS (dB)	PREAMP FACTOR (dB)	ANTENNA HEIGHT (cm)	TABLE ANGLE (Degree)	REMARK
5108	43.58	35.02	54	-10.42	34.45	8.1	33.99	174	154	Average
5108	58.35	49.79	74	-15.65	34.45	8.1	33.99	174	154	Peak
5230	87.97	79.27			34.49	8.22	34.01	174	154	Average
5230	96.52	87.82			34.49	8.22	34.01	174	154	Peak
5360	43.65	34.8	54	-10.35	34.5	8.38	34.03	174	154	Average
5360	58.08	49.23	74	-15.92	34.5	8.38	34.03	174	154	Peak
ANTENNA POLARITY & TEST DISTANCE: VERTICAL AT 3 M										
FREQ. (MHz)	EMISSION LEVEL (dBuV/m)	READ LEVEL (dBuV)	LIMIT (dBuV/m)	MARGIN (dB)	ANTENNA FACTOR (dB/m)	CABLE LOSS (dB)	PREAMP FACTOR (dB)	ANTENNA HEIGHT (cm)	TABLE ANGLE (Degree)	REMARK
5034	44.67	36.23	54	-9.33	34.41	8	33.97	130	186	Average
5034	57.97	49.53	74	-16.03	34.41	8	33.97	130	186	Peak
5230	92.88	84.18			34.49	8.22	34.01	130	186	Average
5230	101.65	92.95			34.49	8.22	34.01	130	186	Peak
5456	44.73	35.77	54	-9.27	34.5	8.51	34.05	130	186	Average
5456	58.17	49.21	74	-15.83	34.5	8.51	34.05	130	186	Peak

REMARKS:

- Emission Level = Read Level + Antenna Factor + Cable Loss - Preamp Factor
Margin value = Emission level – Limit value
- 5230MHz: Fundamental frequency.



MODE B

802.11n (20MHz)

EUT TEST CONDITION		MEASUREMENT DETAIL	
CHANNEL	Channel 36	FREQUENCY RANGE	1GHz ~ 40GHz
INPUT POWER (SYSTEM)	120Vac, 60 Hz	DETECTOR FUNCTION	Peak (PK) Average (AV)
ENVIRONMENTAL CONDITIONS	25deg. C, 65%RH	TESTED BY	Kay Wu

ANTENNA POLARITY & TEST DISTANCE: HORIZONTAL AT 3 M										
FREQ. (MHz)	EMISSION LEVEL (dBuV/m)	READ LEVEL (dBuV)	LIMIT (dBuV/m)	MARGIN (dB)	ANTENNA FACTOR (dB/m)	CABLE LOSS (dB)	PREAMP FACTOR (dB)	ANTENNA HEIGHT (cm)	TABLE ANGLE (Degree)	REMARK
5044	44.99	36.55	54	-9.01	34.42	8	33.98	161	330	Average
5044	59.77	51.33	74	-14.23	34.42	8	33.98	161	330	Peak
5180	91.97	83.34			34.47	8.16	34	161	330	Average
5180	98.72	90.09			34.47	8.16	34	161	330	Peak
5450	45.12	36.16	54	-8.88	34.5	8.51	34.05	161	330	Average
5450	58.63	49.67	74	-15.37	34.5	8.51	34.05	161	330	Peak

ANTENNA POLARITY & TEST DISTANCE: VERTICAL AT 3 M										
FREQ. (MHz)	EMISSION LEVEL (dBuV/m)	READ LEVEL (dBuV)	LIMIT (dBuV/m)	MARGIN (dB)	ANTENNA FACTOR (dB/m)	CABLE LOSS (dB)	PREAMP FACTOR (dB)	ANTENNA HEIGHT (cm)	TABLE ANGLE (Degree)	REMARK
5042	44.99	36.55	54	-9.01	34.42	8	33.98	148	15	Average
5042	59.32	50.88	74	-14.68	34.42	8	33.98	148	15	Peak
5180	97.87	89.24			34.47	8.16	34	148	15	Average
5180	105.55	96.92			34.47	8.16	34	148	15	Peak
5388	45.25	36.38	54	-8.75	34.5	8.41	34.04	148	15	Average
5388	59.08	50.21	74	-14.92	34.5	8.41	34.04	148	15	Peak

REMARKS:

- Emission Level = Read Level + Antenna Factor + Cable Loss - Preamp Factor
Margin value = Emission level – Limit value
- 5180MHz: Fundamental frequency.



A D T

EUT TEST CONDITION		MEASUREMENT DETAIL	
CHANNEL	Channel 44	FREQUENCY RANGE	1GHz ~ 40GHz
INPUT POWER (SYSTEM)	120Vac, 60 Hz	DETECTOR FUNCTION	Peak (PK) Average (AV)
ENVIRONMENTAL CONDITIONS	25deg. C, 65%RH	TESTED BY	Kay Wu

ANTENNA POLARITY & TEST DISTANCE: HORIZONTAL AT 3 M										
FREQ. (MHz)	EMISSION LEVEL (dBuV/m)	READ LEVEL (dBuV)	LIMIT (dBuV/m)	MARGIN (dB)	ANTENNA FACTOR (dB/m)	CABLE LOSS (dB)	PREAMP FACTOR (dB)	ANTENNA HEIGHT (cm)	TABLE ANGLE (Degree)	REMARK
5046	44.54	36.1	54	-9.46	34.42	8	33.98	160	336	Average
5046	58.89	50.45	74	-15.11	34.42	8	33.98	160	336	Peak
5220	91.3	82.59			34.49	8.22	34	160	336	Average
5220	97.52	88.81			34.49	8.22	34	160	336	Peak
5432	44.53	35.59	54	-9.47	34.5	8.48	34.04	160	336	Average
5432	60.45	51.51	74	-13.55	34.5	8.48	34.04	160	336	Peak
ANTENNA POLARITY & TEST DISTANCE: VERTICAL AT 3 M										
FREQ. (MHz)	EMISSION LEVEL (dBuV/m)	READ LEVEL (dBuV)	LIMIT (dBuV/m)	MARGIN (dB)	ANTENNA FACTOR (dB/m)	CABLE LOSS (dB)	PREAMP FACTOR (dB)	ANTENNA HEIGHT (cm)	TABLE ANGLE (Degree)	REMARK
5108	45.2	36.64	54	-8.8	34.45	8.1	33.99	147	16	Average
5108	58.68	50.12	74	-15.32	34.45	8.1	33.99	147	16	Peak
5220	98.33	89.62			34.49	8.22	34	147	16	Average
5220	104.53	95.82			34.49	8.22	34	147	16	Peak
5460	44.53	35.57	54	-9.47	34.5	8.51	34.05	147	16	Average
5460	58.45	49.49	74	-15.55	34.5	8.51	34.05	147	16	Peak

REMARKS:

- Emission Level = Read Level + Antenna Factor + Cable Loss - Preamp Factor
Margin value = Emission level – Limit value
- 5220MHz: Fundamental frequency.



A D T

EUT TEST CONDITION		MEASUREMENT DETAIL	
CHANNEL	Channel 48	FREQUENCY RANGE	1GHz ~ 40GHz
INPUT POWER (SYSTEM)	120Vac, 60 Hz	DETECTOR FUNCTION	Peak (PK) Average (AV)
ENVIRONMENTAL CONDITIONS	25deg. C, 65%RH	TESTED BY	Harry Hsueh

ANTENNA POLARITY & TEST DISTANCE: HORIZONTAL AT 3 M										
FREQ. (MHz)	EMISSION LEVEL (dBuV/m)	READ LEVEL (dBuV)	LIMIT (dBuV/m)	MARGIN (dB)	ANTENNA FACTOR (dB/m)	CABLE LOSS (dB)	PREAMP FACTOR (dB)	ANTENNA HEIGHT (cm)	TABLE ANGLE (Degree)	REMARK
5092	42.59	34.42	54	-11.41	34.08	8.07	33.98	151	330	Average
5092	57.19	49.02	74	-16.81	34.08	8.07	33.98	151	330	Peak
5240	87.23	78.79			34.19	8.26	34.01	151	330	Average
5240	94.24	85.8			34.19	8.26	34.01	151	330	Peak
5358	43.42	34.79	54	-10.58	34.28	8.38	34.03	151	330	Average
5358	58.93	50.3	74	-15.07	34.28	8.38	34.03	151	330	Peak
ANTENNA POLARITY & TEST DISTANCE: VERTICAL AT 3 M										
FREQ. (MHz)	EMISSION LEVEL (dBuV/m)	READ LEVEL (dBuV)	LIMIT (dBuV/m)	MARGIN (dB)	ANTENNA FACTOR (dB/m)	CABLE LOSS (dB)	PREAMP FACTOR (dB)	ANTENNA HEIGHT (cm)	TABLE ANGLE (Degree)	REMARK
5078	43.28	35.16	54	-10.72	34.07	8.03	33.98	111	358	Average
5078	57.08	48.96	74	-16.92	34.07	8.03	33.98	111	358	Peak
5240	95.09	86.65			34.19	8.26	34.01	111	358	Average
5240	102.58	94.14			34.19	8.26	34.01	111	358	Peak
5442	44.14	35.35	54	-9.86	34.35	8.48	34.04	111	358	Average
5442	58.62	49.83	74	-15.38	34.35	8.48	34.04	111	358	Peak

REMARKS:

- Emission Level = Read Level + Antenna Factor + Cable Loss - Preamp Factor
Margin value = Emission level – Limit value
- 5240MHz: Fundamental frequency.

802.11n (40MHz)

EUT TEST CONDITION		MEASUREMENT DETAIL	
CHANNEL	Channel 38	FREQUENCY RANGE	1GHz ~ 40GHz
INPUT POWER (SYSTEM)	120Vac, 60 Hz	DETECTOR FUNCTION	Peak (PK) Average (AV)
ENVIRONMENTAL CONDITIONS	25deg. C, 65%RH	TESTED BY	Kay Wu

ANTENNA POLARITY & TEST DISTANCE: HORIZONTAL AT 3 M										
FREQ. (MHz)	EMISSION LEVEL (dBuV/m)	READ LEVEL (dBuV)	LIMIT (dBuV/m)	MARGIN (dB)	ANTENNA FACTOR (dB/m)	CABLE LOSS (dB)	PREAMP FACTOR (dB)	ANTENNA HEIGHT (cm)	TABLE ANGLE (Degree)	REMARK
5126	45.21	36.65	54	-8.79	34.45	8.1	33.99	164	336	Average
5126	59.89	51.33	74	-14.11	34.45	8.1	33.99	164	336	Peak
5190	87.65	78.99			34.47	8.19	34	164	336	Average
5190	94.49	85.83			34.47	8.19	34	164	336	Peak
5370	45.03	36.15	54	-8.97	34.5	8.41	34.03	164	336	Average
5370	58.8	49.92	74	-15.2	34.5	8.41	34.03	164	336	Peak
ANTENNA POLARITY & TEST DISTANCE: VERTICAL AT 3 M										
FREQ. (MHz)	EMISSION LEVEL (dBuV/m)	READ LEVEL (dBuV)	LIMIT (dBuV/m)	MARGIN (dB)	ANTENNA FACTOR (dB/m)	CABLE LOSS (dB)	PREAMP FACTOR (dB)	ANTENNA HEIGHT (cm)	TABLE ANGLE (Degree)	REMARK
5068	45.13	36.65	54	-8.87	34.43	8.03	33.98	162	15	Average
5068	58.98	50.5	74	-15.02	34.43	8.03	33.98	162	15	Peak
5190	94.13	85.47			34.47	8.19	34	162	15	Average
5190	101.02	92.36			34.47	8.19	34	162	15	Peak
5414	45.06	36.16	54	-8.94	34.5	8.44	34.04	162	15	Average
5414	59.72	50.82	74	-14.28	34.5	8.44	34.04	162	15	Peak

REMARKS:

- Emission Level = Read Level + Antenna Factor + Cable Loss - Preamp Factor
Margin value = Emission level – Limit value
- 5190MHz: Fundamental frequency.



A D T

EUT TEST CONDITION		MEASUREMENT DETAIL	
CHANNEL	Channel 46	FREQUENCY RANGE	1GHz ~ 40GHz
INPUT POWER (SYSTEM)	120Vac, 60 Hz	DETECTOR FUNCTION	Peak (PK) Average (AV)
ENVIRONMENTAL CONDITIONS	25deg. C, 65%RH	TESTED BY	Kay Wu

ANTENNA POLARITY & TEST DISTANCE: HORIZONTAL AT 3 M										
FREQ. (MHz)	EMISSION LEVEL (dBuV/m)	READ LEVEL (dBuV)	LIMIT (dBuV/m)	MARGIN (dB)	ANTENNA FACTOR (dB/m)	CABLE LOSS (dB)	PREAMP FACTOR (dB)	ANTENNA HEIGHT (cm)	TABLE ANGLE (Degree)	REMARK
5114	45.21	36.65	54	-8.79	34.45	8.1	33.99	158	335	Average
5114	59.83	51.27	74	-14.17	34.45	8.1	33.99	158	335	Peak
5230	87.51	78.81			34.49	8.22	34.01	158	335	Average
5230	94.04	85.34			34.49	8.22	34.01	158	335	Peak
5450	45.12	36.16	54	-8.88	34.5	8.51	34.05	158	335	Average
5450	59	50.04	74	-15	34.5	8.51	34.05	158	335	Peak
ANTENNA POLARITY & TEST DISTANCE: VERTICAL AT 3 M										
FREQ. (MHz)	EMISSION LEVEL (dBuV/m)	READ LEVEL (dBuV)	LIMIT (dBuV/m)	MARGIN (dB)	ANTENNA FACTOR (dB/m)	CABLE LOSS (dB)	PREAMP FACTOR (dB)	ANTENNA HEIGHT (cm)	TABLE ANGLE (Degree)	REMARK
5140	45.2	36.61	54	-8.8	34.45	8.13	33.99	159	17	Average
5140	58.99	50.4	74	-15.01	34.45	8.13	33.99	159	17	Peak
5230	94.06	85.36			34.49	8.22	34.01	159	17	Average
5230	101.91	93.21			34.49	8.22	34.01	159	17	Peak
5450	45.17	36.21	54	-8.83	34.5	8.51	34.05	159	17	Average
5450	58.87	49.91	74	-15.13	34.5	8.51	34.05	159	17	Peak

REMARKS:

- Emission Level = Read Level + Antenna Factor + Cable Loss - Preamp Factor
Margin value = Emission level – Limit value
- 5230MHz: Fundamental frequency.



A D T

MODE C

ABOVE 1GHz DATA: 802.11a

EUT TEST CONDITION		MEASUREMENT DETAIL	
CHANNEL	Channel 36	FREQUENCY RANGE	1GHz ~ 40GHz
INPUT POWER (SYSTEM)	120Vac, 60 Hz	DETECTOR FUNCTION	Peak (PK) Average (AV)
ENVIRONMENTAL CONDITIONS	25deg. C, 65%RH	TESTED BY	Kay Wu

ANTENNA POLARITY & TEST DISTANCE: HORIZONTAL AT 3 M										
FREQ. (MHz)	EMISSION LEVEL (dBuV/m)	READ LEVEL (dBuV)	LIMIT (dBuV/m)	MARGIN (dB)	ANTENNA FACTOR (dB/m)	CABLE LOSS (dB)	PREAMP FACTOR (dB)	ANTENNA HEIGHT (cm)	TABLE ANGLE (Degree)	REMARK
5064	45.99	37.51	54	-8.01	34.43	8.03	33.98	144	159	Average
5064	57.21	48.73	74	-16.79	34.43	8.03	33.98	144	159	Peak
5180	89.52	80.89			34.47	8.16	34	144	159	Average
5180	96.94	88.31			34.47	8.16	34	144	159	Peak
5428	45.5	36.56	54	-8.5	34.5	8.48	34.04	144	159	Average
5428	58.52	49.58	74	-15.48	34.5	8.48	34.04	144	159	Peak

ANTENNA POLARITY & TEST DISTANCE: VERTICAL AT 3 M										
FREQ. (MHz)	EMISSION LEVEL (dBuV/m)	READ LEVEL (dBuV)	LIMIT (dBuV/m)	MARGIN (dB)	ANTENNA FACTOR (dB/m)	CABLE LOSS (dB)	PREAMP FACTOR (dB)	ANTENNA HEIGHT (cm)	TABLE ANGLE (Degree)	REMARK
5126	47.07	38.51	54	-6.93	34.45	8.1	33.99	166	203	Average
5126	63.13	54.57	74	-10.87	34.45	8.1	33.99	166	203	Peak
5180	97.78	89.15			34.47	8.16	34	166	203	Average
5180	104.93	96.3			34.47	8.16	34	166	203	Peak
5448	46.58	37.61	54	-7.42	34.5	8.51	34.04	166	203	Average
5448	64.1	55.13	74	-9.9	34.5	8.51	34.04	166	203	Peak

REMARKS:

- Emission Level = Read Level + Antenna Factor + Cable Loss - Preamp Factor
Margin value = Emission level – Limit value
- 5180MHz: Fundamental frequency.



A D T

EUT TEST CONDITION		MEASUREMENT DETAIL	
CHANNEL	Channel 44	FREQUENCY RANGE	1GHz ~ 40GHz
INPUT POWER (SYSTEM)	120Vac, 60 Hz	DETECTOR FUNCTION	Peak (PK) Average (AV)
ENVIRONMENTAL CONDITIONS	25deg. C, 65%RH	TESTED BY	Kay Wu

ANTENNA POLARITY & TEST DISTANCE: HORIZONTAL AT 3 M										
FREQ. (MHz)	EMISSION LEVEL (dBuV/m)	READ LEVEL (dBuV)	LIMIT (dBuV/m)	MARGIN (dB)	ANTENNA FACTOR (dB/m)	CABLE LOSS (dB)	PREAMP FACTOR (dB)	ANTENNA HEIGHT (cm)	TABLE ANGLE (Degree)	REMARK
5072	44.62	36.14	54	-9.38	34.43	8.03	33.98	144	157	Average
5072	58.24	49.76	74	-15.76	34.43	8.03	33.98	144	157	Peak
5220	89	80.29			34.49	8.22	34	144	157	Average
5220	96.72	88.01			34.49	8.22	34	144	157	Peak
5372	45.03	36.15	54	-8.97	34.5	8.41	34.03	144	157	Average
5372	58.68	49.8	74	-15.32	34.5	8.41	34.03	144	157	Peak
ANTENNA POLARITY & TEST DISTANCE: VERTICAL AT 3 M										
FREQ. (MHz)	EMISSION LEVEL (dBuV/m)	READ LEVEL (dBuV)	LIMIT (dBuV/m)	MARGIN (dB)	ANTENNA FACTOR (dB/m)	CABLE LOSS (dB)	PREAMP FACTOR (dB)	ANTENNA HEIGHT (cm)	TABLE ANGLE (Degree)	REMARK
5142	47.11	38.51	54	-6.89	34.46	8.13	33.99	165	204	Average
5142	58.23	49.63	74	-15.77	34.46	8.13	33.99	165	204	Peak
5220	97.78	89.07			34.49	8.22	34	165	204	Average
5220	105	96.29			34.49	8.22	34	165	204	Peak
5456	46.22	37.26	54	-7.78	34.5	8.51	34.05	165	204	Average
5456	57.86	48.9	74	-16.14	34.5	8.51	34.05	165	204	Peak

REMARKS:

- Emission Level = Read Level + Antenna Factor + Cable Loss - Preamp Factor
Margin value = Emission level – Limit value
- 5220MHz: Fundamental frequency.



A D T

EUT TEST CONDITION		MEASUREMENT DETAIL	
CHANNEL	Channel 48	FREQUENCY RANGE	1GHz ~ 40GHz
INPUT POWER (SYSTEM)	120Vac, 60 Hz	DETECTOR FUNCTION	Peak (PK) Average (AV)
ENVIRONMENTAL CONDITIONS	25deg. C, 65%RH	TESTED BY	Kay Wu

ANTENNA POLARITY & TEST DISTANCE: HORIZONTAL AT 3 M										
FREQ. (MHz)	EMISSION LEVEL (dBuV/m)	READ LEVEL (dBuV)	LIMIT (dBuV/m)	MARGIN (dB)	ANTENNA FACTOR (dB/m)	CABLE LOSS (dB)	PREAMP FACTOR (dB)	ANTENNA HEIGHT (cm)	TABLE ANGLE (Degree)	REMARK
5122	45.7	37.14	54	-8.3	34.45	8.1	33.99	156	140	Average
5122	57.32	48.76	74	-16.68	34.45	8.1	33.99	156	140	Peak
5240	89.81	81.07			34.49	8.26	34.01	156	140	Average
5240	96.41	87.67			34.49	8.26	34.01	156	140	Peak
5384	46.13	37.26	54	-7.87	34.5	8.41	34.04	156	140	Average
5384	57.52	48.65	74	-16.48	34.5	8.41	34.04	156	140	Peak
ANTENNA POLARITY & TEST DISTANCE: VERTICAL AT 3 M										
FREQ. (MHz)	EMISSION LEVEL (dBuV/m)	READ LEVEL (dBuV)	LIMIT (dBuV/m)	MARGIN (dB)	ANTENNA FACTOR (dB/m)	CABLE LOSS (dB)	PREAMP FACTOR (dB)	ANTENNA HEIGHT (cm)	TABLE ANGLE (Degree)	REMARK
5150	48.11	39.52	54	-5.89	34.46	8.13	34	165	204	Average
5150	57.75	49.16	74	-16.25	34.46	8.13	34	165	204	Peak
5240	97.59	88.85			34.49	8.26	34.01	165	204	Average
5240	105.23	96.49			34.49	8.26	34.01	165	204	Peak
5362	46.41	37.56	54	-7.59	34.5	8.38	34.03	165	204	Average
5362	57.33	48.48	74	-16.67	34.5	8.38	34.03	165	204	Peak

REMARKS:

- Emission Level = Read Level + Antenna Factor + Cable Loss - Preamp Factor
Margin value = Emission level – Limit value
- 5240MHz: Fundamental frequency.

802.11n (20MHz)

EUT TEST CONDITION		MEASUREMENT DETAIL	
CHANNEL	Channel 36	FREQUENCY RANGE	1GHz ~ 40GHz
INPUT POWER (SYSTEM)	120Vac, 60 Hz	DETECTOR FUNCTION	Peak (PK) Average (AV)
ENVIRONMENTAL CONDITIONS	25deg. C, 65%RH	TESTED BY	Kay Wu

ANTENNA POLARITY & TEST DISTANCE: HORIZONTAL AT 3 M										
FREQ. (MHz)	EMISSION LEVEL (dBuV/m)	READ LEVEL (dBuV)	LIMIT (dBuV/m)	MARGIN (dB)	ANTENNA FACTOR (dB/m)	CABLE LOSS (dB)	PREAMP FACTOR (dB)	ANTENNA HEIGHT (cm)	TABLE ANGLE (Degree)	REMARK
5120	45.81	37.25	54	-8.19	34.45	8.1	33.99	160	161	Average
5120	59.64	51.08	74	-14.36	34.45	8.1	33.99	160	161	Peak
5180	88.27	79.64			34.47	8.16	34	160	161	Average
5180	95.72	87.09			34.47	8.16	34	160	161	Peak
5360	45.45	36.6	54	-8.55	34.5	8.38	34.03	160	161	Average
5360	59.33	50.48	74	-14.67	34.5	8.38	34.03	160	161	Peak
ANTENNA POLARITY & TEST DISTANCE: VERTICAL AT 3 M										
FREQ. (MHz)	EMISSION LEVEL (dBuV/m)	READ LEVEL (dBuV)	LIMIT (dBuV/m)	MARGIN (dB)	ANTENNA FACTOR (dB/m)	CABLE LOSS (dB)	PREAMP FACTOR (dB)	ANTENNA HEIGHT (cm)	TABLE ANGLE (Degree)	REMARK
5106	47.04	38.51	54	-6.96	34.45	8.07	33.99	165	206	Average
5106	60.77	52.24	74	-13.23	34.45	8.07	33.99	165	206	Peak
5180	97.57	88.94			34.47	8.16	34	165	206	Average
5180	104.52	95.89			34.47	8.16	34	165	206	Peak
5452	45.57	36.61	54	-8.43	34.5	8.51	34.05	165	206	Average
5452	60.77	51.81	74	-13.23	34.5	8.51	34.05	165	206	Peak

REMARKS:

- Emission Level = Read Level + Antenna Factor + Cable Loss - Preamp Factor
Margin value = Emission level – Limit value
- 5180MHz: Fundamental frequency.



A D T

EUT TEST CONDITION		MEASUREMENT DETAIL	
CHANNEL	Channel 44	FREQUENCY RANGE	1GHz ~ 40GHz
INPUT POWER (SYSTEM)	120Vac, 60 Hz	DETECTOR FUNCTION	Peak (PK) Average (AV)
ENVIRONMENTAL CONDITIONS	25deg. C, 65%RH	TESTED BY	Kay Wu

ANTENNA POLARITY & TEST DISTANCE: HORIZONTAL AT 3 M										
FREQ. (MHz)	EMISSION LEVEL (dBuV/m)	READ LEVEL (dBuV)	LIMIT (dBuV/m)	MARGIN (dB)	ANTENNA FACTOR (dB/m)	CABLE LOSS (dB)	PREAMP FACTOR (dB)	ANTENNA HEIGHT (cm)	TABLE ANGLE (Degree)	REMARK
5086	45.07	36.55	54	-8.93	34.43	8.07	33.98	142	158	Average
5086	56.95	48.43	74	-17.05	34.43	8.07	33.98	142	158	Peak
5220	87.95	79.24			34.49	8.22	34	142	158	Average
5220	95.99	87.28			34.49	8.22	34	142	158	Peak
5436	46.54	37.6	54	-7.46	34.5	8.48	34.04	142	158	Average
5436	57.91	48.97	74	-16.09	34.5	8.48	34.04	142	158	Peak
ANTENNA POLARITY & TEST DISTANCE: VERTICAL AT 3 M										
FREQ. (MHz)	EMISSION LEVEL (dBuV/m)	READ LEVEL (dBuV)	LIMIT (dBuV/m)	MARGIN (dB)	ANTENNA FACTOR (dB/m)	CABLE LOSS (dB)	PREAMP FACTOR (dB)	ANTENNA HEIGHT (cm)	TABLE ANGLE (Degree)	REMARK
5134	46.14	37.55	54	-7.86	34.45	8.13	33.99	165	205	Average
5134	58.2	49.61	74	-15.8	34.45	8.13	33.99	165	205	Peak
5220	97.35	88.64			34.49	8.22	34	165	205	Average
5220	104.19	95.48			34.49	8.22	34	165	205	Peak
5458	45.57	36.61	54	-8.43	34.5	8.51	34.05	165	205	Average
5458	57.54	48.58	74	-16.46	34.5	8.51	34.05	165	205	Peak

REMARKS:

- Emission Level = Read Level + Antenna Factor + Cable Loss - Preamp Factor
Margin value = Emission level – Limit value
- 5220MHz: Fundamental frequency.



A D T

EUT TEST CONDITION		MEASUREMENT DETAIL	
CHANNEL	Channel 48	FREQUENCY RANGE	1GHz ~ 40GHz
INPUT POWER (SYSTEM)	120Vac, 60 Hz	DETECTOR FUNCTION	Peak (PK) Average (AV)
ENVIRONMENTAL CONDITIONS	25deg. C, 65%RH	TESTED BY	Kay Wu

ANTENNA POLARITY & TEST DISTANCE: HORIZONTAL AT 3 M										
FREQ. (MHz)	EMISSION LEVEL (dBuV/m)	READ LEVEL (dBuV)	LIMIT (dBuV/m)	MARGIN (dB)	ANTENNA FACTOR (dB/m)	CABLE LOSS (dB)	PREAMP FACTOR (dB)	ANTENNA HEIGHT (cm)	TABLE ANGLE (Degree)	REMARK
5082	46.03	37.51	54	-7.97	34.43	8.07	33.98	158	156	Average
5082	59.36	50.84	74	-14.64	34.43	8.07	33.98	158	156	Peak
5240	89.71	80.97			34.49	8.26	34.01	158	156	Average
5240	96.62	87.88			34.49	8.26	34.01	158	156	Peak
5380	45.5	36.63	54	-8.5	34.5	8.41	34.04	158	156	Average
5380	59.51	50.64	74	-14.49	34.5	8.41	34.04	158	156	Peak
ANTENNA POLARITY & TEST DISTANCE: VERTICAL AT 3 M										
FREQ. (MHz)	EMISSION LEVEL (dBuV/m)	READ LEVEL (dBuV)	LIMIT (dBuV/m)	MARGIN (dB)	ANTENNA FACTOR (dB/m)	CABLE LOSS (dB)	PREAMP FACTOR (dB)	ANTENNA HEIGHT (cm)	TABLE ANGLE (Degree)	REMARK
5144	44.94	36.35	54	-9.06	34.46	8.13	34	162	204	Average
5144	58.84	50.25	74	-15.16	34.46	8.13	34	162	204	Peak
5240	98	89.26			34.49	8.26	34.01	162	204	Average
5240	105.03	96.29			34.49	8.26	34.01	162	204	Peak
5410	46.51	37.61	54	-7.49	34.5	8.44	34.04	162	204	Average
5410	60.19	51.29	74	-13.81	34.5	8.44	34.04	162	204	Peak

REMARKS:

- Emission Level = Read Level + Antenna Factor + Cable Loss - Preamp Factor
Margin value = Emission level – Limit value
- 5240MHz: Fundamental frequency.

802.11n (40MHz)

EUT TEST CONDITION		MEASUREMENT DETAIL	
CHANNEL	Channel 38	FREQUENCY RANGE	1GHz ~ 40GHz
INPUT POWER (SYSTEM)	120Vac, 60 Hz	DETECTOR FUNCTION	Peak (PK) Average (AV)
ENVIRONMENTAL CONDITIONS	25deg. C, 65%RH	TESTED BY	Harry Hsueh

ANTENNA POLARITY & TEST DISTANCE: HORIZONTAL AT 3 M										
FREQ. (MHz)	EMISSION LEVEL (dBuV/m)	READ LEVEL (dBuV)	LIMIT (dBuV/m)	MARGIN (dB)	ANTENNA FACTOR (dB/m)	CABLE LOSS (dB)	PREAMP FACTOR (dB)	ANTENNA HEIGHT (cm)	TABLE ANGLE (Degree)	REMARK
5128	44.77	36.55	54	-9.23	34.11	8.1	33.99	100	145	Average
5128	57.4	49.18	74	-16.6	34.11	8.1	33.99	100	145	Peak
5190	83.23	74.89			34.15	8.19	34	100	145	Average
5190	90.76	82.42			34.15	8.19	34	100	145	Peak
5372	44.81	36.14	54	-9.19	34.29	8.41	34.03	100	145	Average
5372	57.46	48.79	74	-16.54	34.29	8.41	34.03	100	145	Peak
ANTENNA POLARITY & TEST DISTANCE: VERTICAL AT 3 M										
FREQ. (MHz)	EMISSION LEVEL (dBuV/m)	READ LEVEL (dBuV)	LIMIT (dBuV/m)	MARGIN (dB)	ANTENNA FACTOR (dB/m)	CABLE LOSS (dB)	PREAMP FACTOR (dB)	ANTENNA HEIGHT (cm)	TABLE ANGLE (Degree)	REMARK
5148	45.82	37.57	54	-8.18	34.12	8.13	34	100	271	Average
5148	59.68	51.43	74	-14.32	34.12	8.13	34	100	271	Peak
5190	93.57	85.23			34.15	8.19	34	100	271	Average
5190	100.71	92.37			34.15	8.19	34	100	271	Peak
5448	45.44	36.61	54	-8.56	34.36	8.51	34.04	100	271	Average
5448	57.5	48.67	74	-16.5	34.36	8.51	34.04	100	271	Peak

REMARKS:

- Emission Level = Read Level + Antenna Factor + Cable Loss - Preamp Factor
Margin value = Emission level – Limit value
- 5190MHz: Fundamental frequency.



A D T

EUT TEST CONDITION		MEASUREMENT DETAIL	
CHANNEL	Channel 46	FREQUENCY RANGE	1GHz ~ 40GHz
INPUT POWER (SYSTEM)	120Vac, 60 Hz	DETECTOR FUNCTION	Peak (PK) Average (AV)
ENVIRONMENTAL CONDITIONS	25deg. C, 65%RH	TESTED BY	Kay Wu

ANTENNA POLARITY & TEST DISTANCE: HORIZONTAL AT 3 M										
FREQ. (MHz)	EMISSION LEVEL (dBuV/m)	READ LEVEL (dBuV)	LIMIT (dBuV/m)	MARGIN (dB)	ANTENNA FACTOR (dB/m)	CABLE LOSS (dB)	PREAMP FACTOR (dB)	ANTENNA HEIGHT (cm)	TABLE ANGLE (Degree)	REMARK
5060	46.03	37.55	54	-7.97	34.43	8.03	33.98	158	162	Average
5060	59.54	51.06	74	-14.46	34.43	8.03	33.98	158	162	Peak
5230	84.28	75.58			34.49	8.22	34.01	158	162	Average
5230	91.61	82.91			34.49	8.22	34.01	158	162	Peak
5446	46.56	37.59	54	-7.44	34.5	8.51	34.04	158	162	Average
5446	60	51.03	74	-14	34.5	8.51	34.04	158	162	Peak
ANTENNA POLARITY & TEST DISTANCE: VERTICAL AT 3 M										
FREQ. (MHz)	EMISSION LEVEL (dBuV/m)	READ LEVEL (dBuV)	LIMIT (dBuV/m)	MARGIN (dB)	ANTENNA FACTOR (dB/m)	CABLE LOSS (dB)	PREAMP FACTOR (dB)	ANTENNA HEIGHT (cm)	TABLE ANGLE (Degree)	REMARK
5020	45.91	37.5	54	-8.09	34.41	7.97	33.97	164	203	Average
5020	58.65	50.24	74	-15.35	34.41	7.97	33.97	164	203	Peak
5230	93.39	84.69			34.49	8.22	34.01	164	203	Average
5230	100.99	92.29			34.49	8.22	34.01	164	203	Peak
5420	46.54	37.6	54	-7.46	34.5	8.48	34.04	164	203	Average
5420	57.31	48.37	74	-16.69	34.5	8.48	34.04	164	203	Peak

REMARKS:

- Emission Level = Read Level + Antenna Factor + Cable Loss - Preamp Factor
Margin value = Emission level – Limit value
- 5230MHz: Fundamental frequency.



MODE D

802.11n (20MHz)

EUT TEST CONDITION		MEASUREMENT DETAIL	
CHANNEL	Channel 36	FREQUENCY RANGE	1GHz ~ 40GHz
INPUT POWER (SYSTEM)	120Vac, 60 Hz	DETECTOR FUNCTION	Peak (PK) Average (AV)
ENVIRONMENTAL CONDITIONS	25deg. C, 65%RH	TESTED BY	Kay Wu

ANTENNA POLARITY & TEST DISTANCE: HORIZONTAL AT 3 M										
FREQ. (MHz)	EMISSION LEVEL (dBuV/m)	READ LEVEL (dBuV)	LIMIT (dBuV/m)	MARGIN (dB)	ANTENNA FACTOR (dB/m)	CABLE LOSS (dB)	PREAMP FACTOR (dB)	ANTENNA HEIGHT (cm)	TABLE ANGLE (Degree)	REMARK
5032	45.07	36.63	54	-8.93	34.41	8	33.97	141	157	Average
5032	59.75	51.31	74	-14.25	34.41	8	33.97	141	157	Peak
5180	88.9	80.27			34.47	8.16	34	141	157	Average
5180	96.64	88.01			34.47	8.16	34	141	157	Peak
5420	45.64	36.7	54	-8.36	34.5	8.48	34.04	141	157	Average
5420	59.74	50.8	74	-14.26	34.5	8.48	34.04	141	157	Peak

ANTENNA POLARITY & TEST DISTANCE: VERTICAL AT 3 M										
FREQ. (MHz)	EMISSION LEVEL (dBuV/m)	READ LEVEL (dBuV)	LIMIT (dBuV/m)	MARGIN (dB)	ANTENNA FACTOR (dB/m)	CABLE LOSS (dB)	PREAMP FACTOR (dB)	ANTENNA HEIGHT (cm)	TABLE ANGLE (Degree)	REMARK
5124	45.11	36.55	54	-8.89	34.45	8.1	33.99	162	219	Average
5124	58.87	50.31	74	-15.13	34.45	8.1	33.99	162	219	Peak
5180	98	89.37			34.47	8.16	34	162	219	Average
5180	105.11	96.48			34.47	8.16	34	162	219	Peak
5420	45.63	36.69	54	-8.37	34.5	8.48	34.04	162	219	Average
5420	59.6	50.66	74	-14.4	34.5	8.48	34.04	162	219	Peak

REMARKS:

- Emission Level = Read Level + Antenna Factor + Cable Loss - Preamp Factor
Margin value = Emission level – Limit value
- 5180MHz: Fundamental frequency.



A D T

EUT TEST CONDITION		MEASUREMENT DETAIL	
CHANNEL	Channel 44	FREQUENCY RANGE	1GHz ~ 40GHz
INPUT POWER (SYSTEM)	120Vac, 60 Hz	DETECTOR FUNCTION	Peak (PK) Average (AV)
ENVIRONMENTAL CONDITIONS	25deg. C, 65%RH	TESTED BY	Kay Wu

ANTENNA POLARITY & TEST DISTANCE: HORIZONTAL AT 3 M										
FREQ. (MHz)	EMISSION LEVEL (dBuV/m)	READ LEVEL (dBuV)	LIMIT (dBuV/m)	MARGIN (dB)	ANTENNA FACTOR (dB/m)	CABLE LOSS (dB)	PREAMP FACTOR (dB)	ANTENNA HEIGHT (cm)	TABLE ANGLE (Degree)	REMARK
5044	45.69	37.25	54	-8.31	34.42	8	33.98	139	157	Average
5044	59.53	51.09	74	-14.47	34.42	8	33.98	139	157	Peak
5220	88.71	80			34.49	8.22	34	139	157	Average
5220	96.87	88.16			34.49	8.22	34	139	157	Peak
5426	45.54	36.6	54	-8.46	34.5	8.48	34.04	139	157	Average
5426	59.13	50.19	74	-14.87	34.5	8.48	34.04	139	157	Peak
ANTENNA POLARITY & TEST DISTANCE: VERTICAL AT 3 M										
FREQ. (MHz)	EMISSION LEVEL (dBuV/m)	READ LEVEL (dBuV)	LIMIT (dBuV/m)	MARGIN (dB)	ANTENNA FACTOR (dB/m)	CABLE LOSS (dB)	PREAMP FACTOR (dB)	ANTENNA HEIGHT (cm)	TABLE ANGLE (Degree)	REMARK
5092	45.16	36.63	54	-8.84	34.44	8.07	33.98	163	204	Average
5092	59.16	50.63	74	-14.84	34.44	8.07	33.98	163	204	Peak
5220	97.38	88.67			34.49	8.22	34	163	204	Average
5220	104.95	96.24			34.49	8.22	34	163	204	Peak
5356	46.41	37.56	54	-7.59	34.5	8.38	34.03	163	204	Average
5356	59.74	50.89	74	-14.26	34.5	8.38	34.03	163	204	Peak

REMARKS:

- Emission Level = Read Level + Antenna Factor + Cable Loss - Preamp Factor
Margin value = Emission level – Limit value
- 5220MHz: Fundamental frequency.



A D T

EUT TEST CONDITION		MEASUREMENT DETAIL	
CHANNEL	Channel 48	FREQUENCY RANGE	1GHz ~ 40GHz
INPUT POWER (SYSTEM)	120Vac, 60 Hz	DETECTOR FUNCTION	Peak (PK) Average (AV)
ENVIRONMENTAL CONDITIONS	25deg. C, 65%RH	TESTED BY	Harry Hsueh

ANTENNA POLARITY & TEST DISTANCE: HORIZONTAL AT 3 M										
FREQ. (MHz)	EMISSION LEVEL (dBuV/m)	READ LEVEL (dBuV)	LIMIT (dBuV/m)	MARGIN (dB)	ANTENNA FACTOR (dB/m)	CABLE LOSS (dB)	PREAMP FACTOR (dB)	ANTENNA HEIGHT (cm)	TABLE ANGLE (Degree)	REMARK
5106	44.73	36.56	54	-9.27	34.09	8.07	33.99	163	152	Average
5106	56.9	48.73	74	-17.1	34.09	8.07	33.99	163	152	Peak
5240	90.01	81.57			34.19	8.26	34.01	163	152	Average
5240	98.54	90.1			34.19	8.26	34.01	163	152	Peak
5416	44.88	36.15	54	-9.12	34.33	8.44	34.04	163	152	Average
5416	57.42	48.69	74	-16.58	34.33	8.44	34.04	163	152	Peak
ANTENNA POLARITY & TEST DISTANCE: VERTICAL AT 3 M										
FREQ. (MHz)	EMISSION LEVEL (dBuV/m)	READ LEVEL (dBuV)	LIMIT (dBuV/m)	MARGIN (dB)	ANTENNA FACTOR (dB/m)	CABLE LOSS (dB)	PREAMP FACTOR (dB)	ANTENNA HEIGHT (cm)	TABLE ANGLE (Degree)	REMARK
5066	44.61	36.51	54	-9.39	34.05	8.03	33.98	111	274	Average
5066	57.32	49.22	74	-16.68	34.05	8.03	33.98	111	274	Peak
5240	100.43	91.99			34.19	8.26	34.01	111	274	Average
5240	107.11	98.67			34.19	8.26	34.01	111	274	Peak
5350	46.23	37.6	54	-7.77	34.28	8.38	34.03	111	274	Average
5350	55.41	46.78	74	-18.59	34.28	8.38	34.03	111	274	Peak

REMARKS:

- Emission Level = Read Level + Antenna Factor + Cable Loss - Preamp Factor
Margin value = Emission level – Limit value
- 5240MHz: Fundamental frequency.



802.11n (40MHz)

EUT TEST CONDITION		MEASUREMENT DETAIL	
CHANNEL	Channel 38	FREQUENCY RANGE	1GHz ~ 40GHz
INPUT POWER (SYSTEM)	120Vac, 60 Hz	DETECTOR FUNCTION	Peak (PK) Average (AV)
ENVIRONMENTAL CONDITIONS	25deg. C, 65%RH	TESTED BY	Kay Wu

ANTENNA POLARITY & TEST DISTANCE: HORIZONTAL AT 3 M										
FREQ. (MHz)	EMISSION LEVEL (dBuV/m)	READ LEVEL (dBuV)	LIMIT (dBuV/m)	MARGIN (dB)	ANTENNA FACTOR (dB/m)	CABLE LOSS (dB)	PREAMP FACTOR (dB)	ANTENNA HEIGHT (cm)	TABLE ANGLE (Degree)	REMARK
5062	46.03	37.55	54	-7.97	34.43	8.03	33.98	145	182	Average
5062	60.22	51.74	74	-13.78	34.43	8.03	33.98	145	182	Peak
5190	85.63	76.97			34.47	8.19	34	145	182	Average
5190	92.98	84.32			34.47	8.19	34	145	182	Peak
5418	45.83	36.93	54	-8.17	34.5	8.44	34.04	145	182	Average
5418	61.15	52.25	74	-12.85	34.5	8.44	34.04	145	182	Peak
ANTENNA POLARITY & TEST DISTANCE: VERTICAL AT 3 M										
FREQ. (MHz)	EMISSION LEVEL (dBuV/m)	READ LEVEL (dBuV)	LIMIT (dBuV/m)	MARGIN (dB)	ANTENNA FACTOR (dB/m)	CABLE LOSS (dB)	PREAMP FACTOR (dB)	ANTENNA HEIGHT (cm)	TABLE ANGLE (Degree)	REMARK
5030	45.98	37.54	54	-8.02	34.41	8	33.97	162	221	Average
5030	59.43	50.99	74	-14.57	34.41	8	33.97	162	221	Peak
5190	94.26	85.6			34.47	8.19	34	162	221	Average
5190	101.22	92.56			34.47	8.19	34	162	221	Peak
5440	46.54	37.6	54	-7.46	34.5	8.48	34.04	162	221	Average
5440	60.16	51.22	74	-13.84	34.5	8.48	34.04	162	221	Peak

REMARKS:

- Emission Level = Read Level + Antenna Factor + Cable Loss - Preamp Factor
Margin value = Emission level – Limit value
- 5190MHz: Fundamental frequency.



A D T

EUT TEST CONDITION		MEASUREMENT DETAIL	
CHANNEL	Channel 46	FREQUENCY RANGE	1GHz ~ 40GHz
INPUT POWER (SYSTEM)	120Vac, 60 Hz	DETECTOR FUNCTION	Peak (PK) Average (AV)
ENVIRONMENTAL CONDITIONS	25deg. C, 65%RH	TESTED BY	Kay Wu

ANTENNA POLARITY & TEST DISTANCE: HORIZONTAL AT 3 M										
FREQ. (MHz)	EMISSION LEVEL (dBuV/m)	READ LEVEL (dBuV)	LIMIT (dBuV/m)	MARGIN (dB)	ANTENNA FACTOR (dB/m)	CABLE LOSS (dB)	PREAMP FACTOR (dB)	ANTENNA HEIGHT (cm)	TABLE ANGLE (Degree)	REMARK
5132	46.08	37.52	54	-7.92	34.45	8.1	33.99	138	158	Average
5132	60.39	51.83	74	-13.61	34.45	8.1	33.99	138	158	Peak
5230	84.95	76.25			34.49	8.22	34.01	138	158	Average
5230	91.9	83.2			34.49	8.22	34.01	138	158	Peak
5436	45.54	36.6	54	-8.46	34.5	8.48	34.04	138	158	Average
5436	60.2	51.26	74	-13.8	34.5	8.48	34.04	138	158	Peak
ANTENNA POLARITY & TEST DISTANCE: VERTICAL AT 3 M										
FREQ. (MHz)	EMISSION LEVEL (dBuV/m)	READ LEVEL (dBuV)	LIMIT (dBuV/m)	MARGIN (dB)	ANTENNA FACTOR (dB/m)	CABLE LOSS (dB)	PREAMP FACTOR (dB)	ANTENNA HEIGHT (cm)	TABLE ANGLE (Degree)	REMARK
5122	46.11	37.55	54	-7.89	34.45	8.1	33.99	122	276	Average
5122	58.61	50.05	74	-15.39	34.45	8.1	33.99	122	276	Peak
5230	93.71	85.01			34.49	8.22	34.01	122	276	Average
5230	100.36	91.66			34.49	8.22	34.01	122	276	Peak
5416	46.51	37.61	54	-7.49	34.5	8.44	34.04	122	276	Average
5416	60.14	51.24	74	-13.86	34.5	8.44	34.04	122	276	Peak

REMARKS:

- Emission Level = Read Level + Antenna Factor + Cable Loss - Preamp Factor
Margin value = Emission level – Limit value
- 5230MHz: Fundamental frequency.

BELOW 1GHz WORST-CASE DATA :

MODE A

802.11a

EUT TEST CONDITION		MEASUREMENT DETAIL	
CHANNEL	Channel 44	FREQUENCY RANGE	30MHz ~ 1GHz
INPUT POWER (SYSTEM)	120Vac, 60 Hz	DETECTOR FUNCTION	Peak (PK) Average (AV)
ENVIRONMENTAL CONDITIONS	25deg. C, 65%RH	TESTED BY	Harry Hsueh
POWER SUPPLY	adapter		

ANTENNA POLARITY & TEST DISTANCE: HORIZONTAL AT 3 M										
FREQ. (MHz)	EMISSION LEVEL (dBuV/m)	READ LEVEL (dBuV)	LIMIT (dBuV/m)	MARGIN (dB)	ANTENNA FACTOR (dB/m)	CABLE LOSS (dB)	PREAMP FACTOR (dB)	ANTENNA HEIGHT (cm)	TABLE ANGLE (Degree)	REMARK
135.03	33.71	55.33	43.5	-9.79	9.25	1.38	32.25	130	18	Peak
195.24	35.44	55.43	43.5	-8.06	10.68	1.61	32.28	192	247	Peak
240.06	36.07	53.81	46	-9.93	12.54	1.85	32.13	114	82	Peak
339.9	33.57	47.57	46	-12.43	15.89	2.19	32.08	213	89	Peak
623.4	31.08	38.22	46	-14.92	22.1	2.93	32.17	174	200	Peak
995.8	32.47	33.06	54	-21.53	26.04	3.72	30.35	162	187	Peak
ANTENNA POLARITY & test distance: VERTICAL at 3 m										
FREQ. (MHz)	EMISSION LEVEL (dBuV/m)	READ LEVEL (dBuV)	LIMIT (dBuV/m)	MARGIN (dB)	ANTENNA FACTOR (dB/m)	CABLE LOSS (dB)	PREAMP FACTOR (dB)	ANTENNA HEIGHT (cm)	TABLE ANGLE (Degree)	REMARK
59.97	31.22	55.75	40	-8.78	6.8	0.9	32.23	200	0	Peak
119.91	33.79	56.06	43.5	-9.71	8.7	1.28	32.25	145	97	Peak
180.12	31.78	52.01	43.5	-11.72	10.4	1.61	32.24	134	66	Peak
449.8	30.9	42.56	46	-15.1	18	2.49	32.15	100	69	Peak
720	30.58	36.22	46	-15.42	23.31	3.16	32.11	112	196	Peak
999.3	35.11	35.59	54	-18.89	26.1	3.72	30.3	102	118	Peak

REMARKS: Emission Level = Read Level + Antenna Factor + Cable Loss - Preamp Factor



A D T

802.11a

EUT TEST CONDITION		MEASUREMENT DETAIL	
CHANNEL	Channel 44	FREQUENCY RANGE	30MHz ~ 1GHz
INPUT POWER (SYSTEM)	120Vac, 60 Hz	DETECTOR FUNCTION	Peak (PK) Average (AV)
ENVIRONMENTAL CONDITIONS	25deg. C, 65%RH	TESTED BY	Harry Hsueh
POWER SUPPLY	POE		

ANTENNA POLARITY & TEST DISTANCE: HORIZONTAL AT 3 M

FREQ. (MHz)	EMISSION LEVEL (dBuV/m)	READ LEVEL (dBuV)	LIMIT (dBuV/m)	MARGIN (dB)	ANTENNA FACTOR (dB/m)	CABLE LOSS (dB)	PREAMP FACTOR (dB)	ANTENNA HEIGHT (cm)	TABLE ANGLE (Degree)	REMARK
98.85	36.05	57.4	43.5	-7.45	9.58	1.28	32.21	116	93	Peak
139.89	30.98	52.57	43.5	-12.52	9.3	1.38	32.27	108	69	Peak
275.16	30.5	46.97	46	-15.5	13.71	1.94	32.12	106	174	Peak
349.7	33.85	47.33	46	-12.15	16.4	2.19	32.07	121	165	Peak
449.8	28.23	39.89	46	-17.77	18	2.49	32.15	139	207	Peak
799.8	34.76	38.9	46	-11.24	24.6	3.32	32.06	168	239	Peak

ANTENNA POLARITY & test distance: VERTICAL at 3 m

FREQ. (MHz)	EMISSION LEVEL (dBuV/m)	READ LEVEL (dBuV)	LIMIT (dBuV/m)	MARGIN (dB)	ANTENNA FACTOR (dB/m)	CABLE LOSS (dB)	PREAMP FACTOR (dB)	ANTENNA HEIGHT (cm)	TABLE ANGLE (Degree)	REMARK
48.9	26.7	49.88	40	-13.3	8.14	0.9	32.22	102	313	Peak
90.75	37.56	59.24	43.5	-5.94	8.98	1.11	31.77	189	200	Peak
250.05	27.87	45.12	46	-18.13	13	1.85	32.1	107	115	Peak
615.7	29.81	37.25	46	-16.19	21.81	2.93	32.18	166	112	Peak
799.1	36.58	40.72	46	-9.42	24.6	3.32	32.06	158	232	Peak
906.9	38.5	40.92	46	-7.5	25.48	3.53	31.43	191	101	Peak

REMARKS: Emission Level = Read Level + Antenna Factor + Cable Loss - Preamp Factor



A D T

MODE C

802.11a

EUT TEST CONDITION		MEASUREMENT DETAIL	
CHANNEL	Channel 44	FREQUENCY RANGE	30MHz ~ 1GHz
INPUT POWER (SYSTEM)	120Vac, 60 Hz	DETECTOR FUNCTION	Peak (PK) Average (AV)
ENVIRONMENTAL CONDITIONS	25deg. C, 65%RH	TESTED BY	Harry Hsueh
POWER SUPPLY	POE		

ANTENNA POLARITY & TEST DISTANCE: HORIZONTAL AT 3 M										
FREQ. (MHz)	EMISSION LEVEL (dBuV/m)	READ LEVEL (dBuV)	LIMIT (dBuV/m)	MARGIN (dB)	ANTENNA FACTOR (dB/m)	CABLE LOSS (dB)	PREAMP FACTOR (dB)	ANTENNA HEIGHT (cm)	TABLE ANGLE (Degree)	REMARK
53.49	30.56	54.47	40	-9.44	7.42	0.9	32.23	187	205	Peak
90.21	39.07	60.73	43.5	-4.43	8.94	1.11	31.71	136	101	Peak
147.18	36	56.83	43.5	-7.5	9.92	1.52	32.27	142	78	Peak
374.9	30.65	44.24	46	-15.35	16.3	2.26	32.15	167	84	Peak
624.8	31.69	38.83	46	-14.31	22.1	2.93	32.17	118	38	Peak
875.4	35.37	38.71	46	-10.63	24.8	3.49	31.63	169	187	Peak
ANTENNA POLARITY & test distance: VERTICAL at 3 m										
FREQ. (MHz)	EMISSION LEVEL (dBuV/m)	READ LEVEL (dBuV)	LIMIT (dBuV/m)	MARGIN (dB)	ANTENNA FACTOR (dB/m)	CABLE LOSS (dB)	PREAMP FACTOR (dB)	ANTENNA HEIGHT (cm)	TABLE ANGLE (Degree)	REMARK
77.52	36.58	59.36	40	-3.42	8.33	1.11	32.22	183	229	Peak
98.85	39.09	60.44	43.5	-4.41	9.58	1.28	32.21	194	209	Peak
171.48	35.82	56.47	43.5	-7.68	10.07	1.52	32.24	114	138	Peak
449.8	33.25	44.91	46	-12.75	18	2.49	32.15	145	91	Peak
624.8	36.95	44.09	46	-9.05	22.1	2.93	32.17	163	79	Peak
873.3	35.87	39.28	46	-10.13	24.8	3.44	31.65	112	188	Peak

REMARKS: Emission Level = Read Level + Antenna Factor + Cable Loss - Preamp Factor

4.2 CONDUCTED EMISSION MEASUREMENT

4.2.1 LIMITS OF CONDUCTED EMISSION MEASUREMENT

FREQUENCY OF EMISSION (MHz)	CONDUCTED LIMIT (dB μ V)	
	Quasi-peak	Average
0.15 ~ 0.5	66 to 56	56 to 46
0.5 ~ 5	56	46
5 ~ 30	60	50

- NOTE:** 1. The lower limit shall apply at the transition frequencies.
 2. The limit decreases in line with the logarithm of the frequency in the range of 0.15 to 0.50MHz.
 3. All emanations from a class A/B digital device or system, including any network of conductors and apparatus connected thereto, shall not exceed the level of field strengths specified above.

4.2.2 TEST INSTRUMENTS

DESCRIPTION & MANUFACTURER	MODEL NO.	SERIAL NO.	DATE OF CALIBRATION	DUE DATE OF CALIBRATION
Test Receiver ROHDE & SCHWARZ	ESCS30	100289	Nov. 29, 2013	Nov. 28, 2014
RF signal cable Woken	5D-FB	Cable-HYC01-01	Dec. 27, 2013	Dec. 26, 2014
LISN ROHDE & SCHWARZ (EUT)	ESH2-Z5	100311	Jul. 17, 2013	Jul. 16, 2014
LISN ROHDE & SCHWARZ (Peripheral)	ESH3-Z5	835239/001	Feb. 04, 2013	Feb. 03, 2014
LISN ROHDE & SCHWARZ (Peripheral)	ESH3-Z5	100311	Jul. 17, 2013	Jul. 16, 2014
Software ADT	BV ADT_Cond_ V7.3.7.3	NA	NA	NA

- NOTE:** 1. The calibration interval of the above test instruments is 12 months and the calibrations are traceable to NML/ROC and NIST/USA.
 2. The test was performed in HwaYa Shielded Room 2.
 3. The VCCI Site Registration No. is C-2047.

4.2.3 TEST PROCEDURES

- The EUT was placed 0.4 meters from the conducting wall of the shielded room with EUT being connected to the power mains through a line impedance stabilization network (LISN). Other support units were connected to the power mains through another LISN. The two LISNs provide 50 ohm/ 50uH of coupling impedance for the measuring instrument.
- Both lines of the power mains connected to the EUT were checked for maximum conducted interference.
- The frequency range from 150kHz to 30MHz was searched. Emission levels under (Limit - 20dB) was not recorded.

NOTE: All modes of operation were investigated and the worst-case emissions are reported.

4.2.4 DEVIATION FROM TEST STANDARD

No deviation.

4.2.5 TEST SETUP

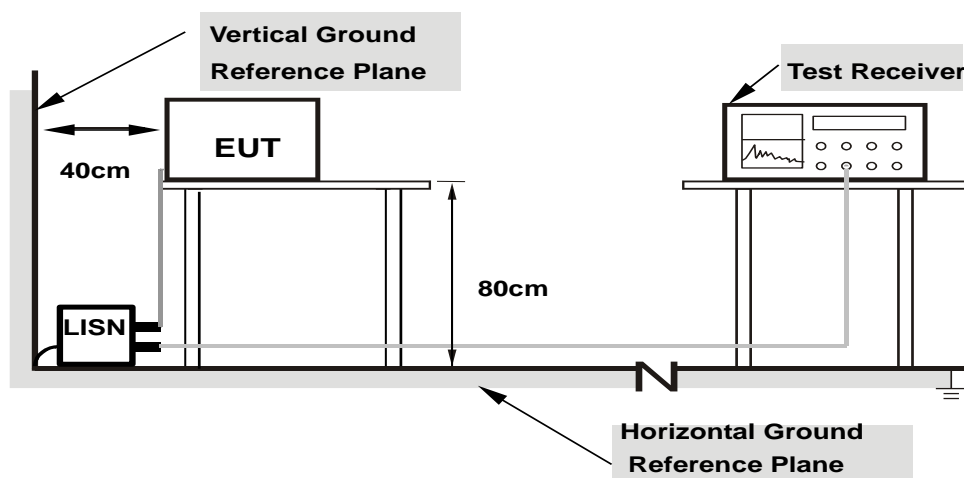

- Note:**
- Support units were connected to second LISN.
 - Both of LISNs (AMN) are 80 cm from EUT and at least 80 from other units and other metal planes

For the actual test configuration, please refer to the attached file (Test Setup Photo).

4.2.6 EUT OPERATING CONDITIONS

Same as 4.1.6.

4.2.7 TEST RESULTS

CONDUCTED WORST-CASE DATA :

MODE A

PHASE	Line 1	6dB BANDWIDTH	9kHz
POWER SUPPLY	adapter		

No	Freq. [MHz]	Corr. Factor (dB)	Reading Value [dB (uV)]		Emission Level [dB (uV)]		Limit [dB (uV)]		Margin (dB)	
			Q.P.	AV.	Q.P.	AV.	Q.P.	AV.	Q.P.	AV.
			1	0.20469	0.28	39.29	25.70	39.57	25.98	63.42
2	0.58359	0.31	33.99	27.56	34.30	27.87	56.00	46.00	-21.70	-18.13
3	2.10156	0.36	19.54	12.92	19.90	13.28	56.00	46.00	-36.10	-32.72
4	4.78906	0.44	17.23	9.73	17.67	10.17	56.00	46.00	-38.33	-35.83
5	12.48047	0.51	23.18	16.46	23.69	16.97	60.00	50.00	-36.31	-33.03
6	23.58984	0.55	27.46	22.16	28.01	22.71	60.00	50.00	-31.99	-27.29

REMARKS:

1. Q.P. and AV. are abbreviations of quasi-peak and average individually.
2. The emission levels of other frequencies were very low against the limit.
3. Margin value = Emission level - Limit value
4. Correction factor = Insertion loss + Cable loss
5. Emission Level = Correction Factor + Reading Value

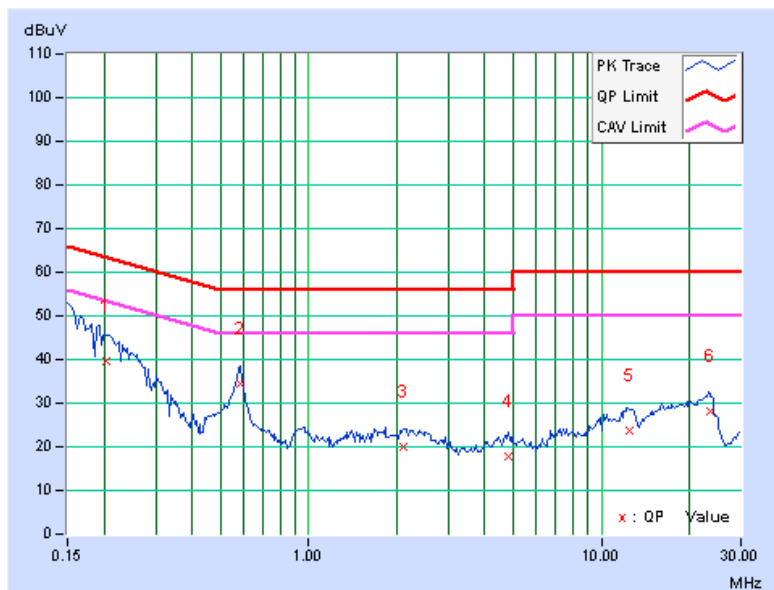



A D T

PHASE	Line 2	6dB BANDWIDTH	9kHz
POWER SUPPLY	adapter		

No	Freq.	Corr. Factor	Reading Value		Emission Level		Limit		Margin	
	[MHz]		[dB (uV)]		[dB (uV)]		[dB (uV)]		(dB)	
			Q.P.	AV.	Q.P.	AV.	Q.P.	AV.	Q.P.	AV.
1	0.22812	0.28	38.99	28.29	39.27	28.57	62.52	52.52	-23.25	-23.95
2	0.57578	0.31	39.21	32.89	39.52	33.20	56.00	46.00	-16.48	-12.80
3	1.74609	0.36	20.24	12.71	20.60	13.07	56.00	46.00	-35.40	-32.93
4	4.27734	0.44	17.99	10.15	18.43	10.59	56.00	46.00	-37.57	-35.41
5	12.82422	0.55	25.63	18.34	26.18	18.89	60.00	50.00	-33.82	-31.11
6	22.93750	0.60	26.88	21.41	27.48	22.01	60.00	50.00	-32.52	-27.99

REMARKS:

1. Q.P. and AV. are abbreviations of quasi-peak and average individually.
2. The emission levels of other frequencies were very low against the limit.
3. Margin value = Emission level - Limit value
4. Correction factor = Insertion loss + Cable loss
5. Emission Level = Correction Factor + Reading Value

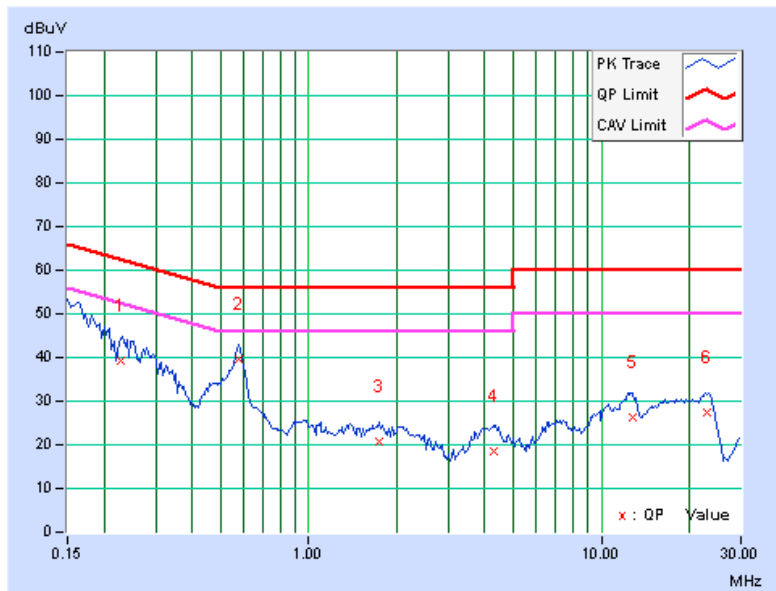

MODE A

PHASE	Line 1	6dB BANDWIDTH	9kHz
POWER SUPPLY	POE		

No	Freq. [MHz]	Corr. Factor (dB)	Reading Value		Emission Level		Limit		Margin	
			[dB (uV)]		[dB (uV)]		[dB (uV)]		(dB)	
			Q.P.	AV.	Q.P.	AV.	Q.P.	AV.	Q.P.	AV.
1	0.24766	0.28	50.88	39.05	51.16	39.33	61.84	51.84	-10.67	-12.50
2	0.33359	0.29	46.20	36.80	46.49	37.09	59.36	49.36	-12.87	-12.27
3	1.33203	0.35	32.57	21.37	32.92	21.72	56.00	46.00	-23.08	-24.28
4	4.55078	0.44	38.22	29.69	38.66	30.13	56.00	46.00	-17.34	-15.87
5	10.85938	0.51	37.22	30.65	37.73	31.16	60.00	50.00	-22.27	-18.84
6	14.89063	0.53	23.00	17.18	23.53	17.71	60.00	50.00	-36.47	-32.29

REMARKS:

1. Q.P. and AV. are abbreviations of quasi-peak and average individually.
2. The emission levels of other frequencies were very low against the limit.
3. Margin value = Emission level - Limit value
4. Correction factor = Insertion loss + Cable loss
5. Emission Level = Correction Factor + Reading Value

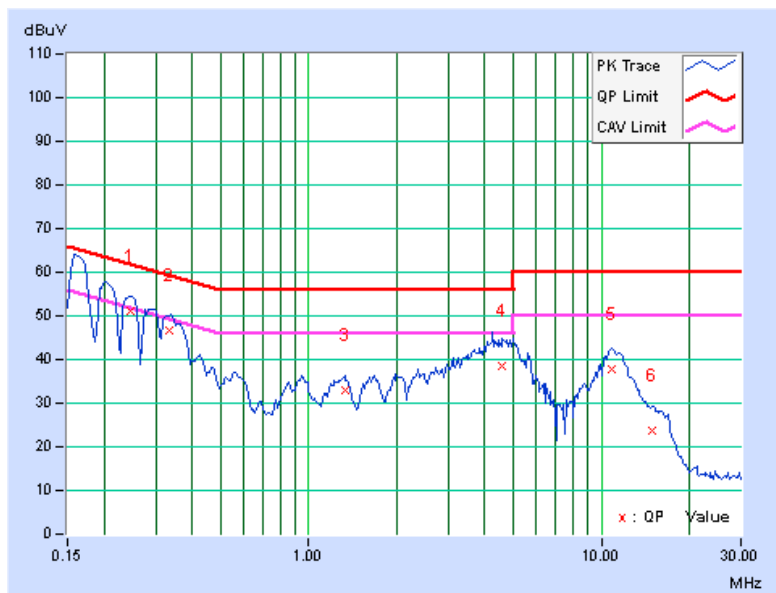



PHASE	Line 2	6dB BANDWIDTH	9kHz
POWER SUPPLY	POE		

No	Freq.	Corr. Factor	Reading Value		Emission Level		Limit		Margin	
	[MHz]		[dB (uV)]		[dB (uV)]		[dB (uV)]		(dB)	
			Q.P.	AV.	Q.P.	AV.	Q.P.	AV.	Q.P.	AV.
1	0.20078	0.28	54.64	40.25	54.92	40.53	63.58	53.58	-8.66	-13.05
2	0.33359	0.29	44.54	35.00	44.83	35.29	59.36	49.36	-14.53	-14.07
3	1.67188	0.36	31.81	21.53	32.17	21.89	56.00	46.00	-23.83	-24.11
4	4.72656	0.45	41.34	35.01	41.79	35.46	56.00	46.00	-14.21	-10.54
5	11.08594	0.53	37.05	30.34	37.58	30.87	60.00	50.00	-22.42	-19.13
6	15.85156	0.58	29.13	23.08	29.71	23.66	60.00	50.00	-30.29	-26.34

REMARKS:

1. Q.P. and AV. are abbreviations of quasi-peak and average individually.
2. The emission levels of other frequencies were very low against the limit.
3. Margin value = Emission level - Limit value
4. Correction factor = Insertion loss + Cable loss
5. Emission Level = Correction Factor + Reading Value

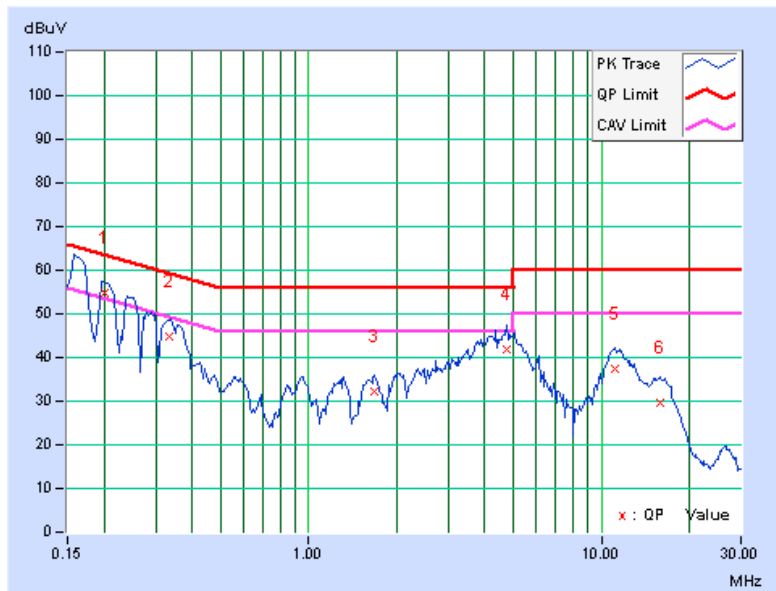



MODE C

PHASE	Line 1	6dB BANDWIDTH	9kHz
POWER SUPPLY	POE		

No	Freq. [MHz]	Corr. Factor (dB)	Reading Value		Emission Level		Limit		Margin	
			[dB (uV)]		[dB (uV)]		[dB (uV)]		(dB)	
			Q.P.	AV.	Q.P.	AV.	Q.P.	AV.	Q.P.	AV.
1	0.16172	0.27	61.66	49.51	61.93	49.78	65.38	55.38	-3.45	-5.60
2	0.23984	0.28	51.41	39.36	51.69	39.64	62.10	52.10	-10.41	-12.46
3	1.33203	0.35	32.93	22.89	33.28	23.24	56.00	46.00	-22.72	-22.76
4	4.69141	0.44	42.59	40.02	43.03	40.46	56.00	46.00	-12.97	-5.54
5	9.87891	0.50	40.52	37.07	41.02	37.57	60.00	50.00	-18.98	-12.43
6	15.42969	0.54	25.39	19.86	25.93	20.40	60.00	50.00	-34.07	-29.60

REMARKS:

1. Q.P. and AV. are abbreviations of quasi-peak and average individually.
2. The emission levels of other frequencies were very low against the limit.
3. Margin value = Emission level - Limit value
4. Correction factor = Insertion loss + Cable loss
5. Emission Level = Correction Factor + Reading Value

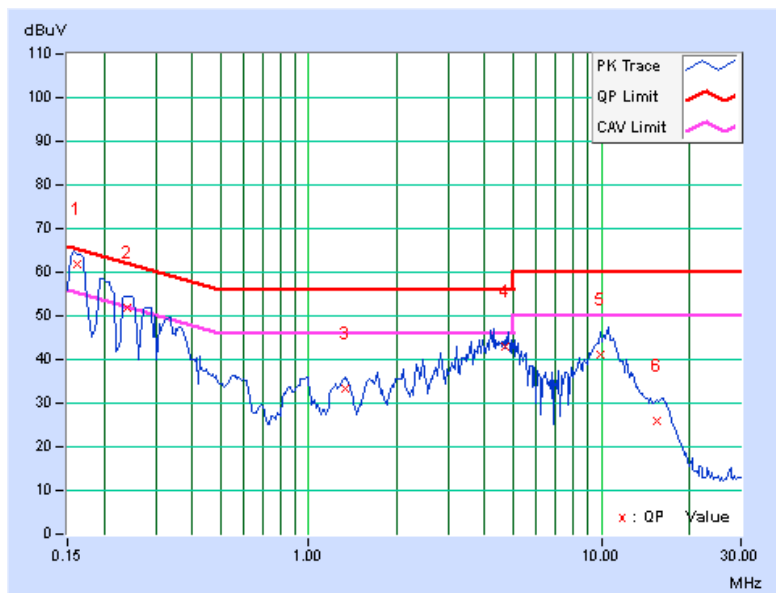



A D T

PHASE	Line 2	6dB BANDWIDTH	9kHz
POWER SUPPLY	POE		

No	Freq.	Corr. Factor	Reading Value		Emission Level		Limit		Margin	
	[MHz]		[dB (uV)]		[dB (uV)]		[dB (uV)]		(dB)	
			Q.P.	AV.	Q.P.	AV.	Q.P.	AV.	Q.P.	AV.
1	0.16562	0.27	60.78	48.14	61.05	48.41	65.18	55.18	-4.13	-6.77
2	0.16562	0.27	60.76	47.09	61.03	47.36	65.18	55.18	-4.15	-7.82
3	1.60547	0.36	32.53	26.02	32.89	26.38	56.00	46.00	-23.11	-19.62
4	4.19922	0.44	41.63	36.54	42.07	36.98	56.00	46.00	-13.93	-9.02
5	10.61719	0.53	42.26	38.46	42.79	38.99	60.00	50.00	-17.21	-11.01
6	16.12500	0.58	31.18	25.10	31.76	25.68	60.00	50.00	-28.24	-24.32

REMARKS:

1. Q.P. and AV. are abbreviations of quasi-peak and average individually.
2. The emission levels of other frequencies were very low against the limit.
3. Margin value = Emission level - Limit value
4. Correction factor = Insertion loss + Cable loss
5. Emission Level = Correction Factor + Reading Value

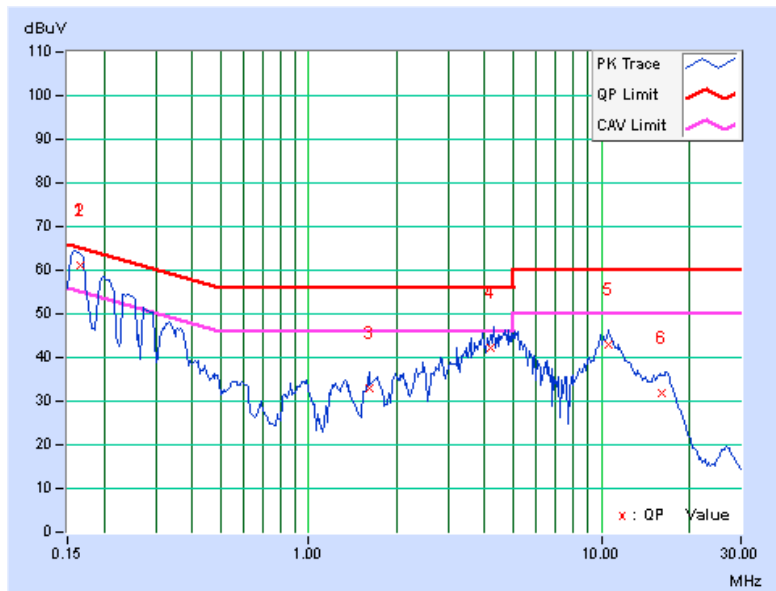

4.3 PEAK TRANSMIT POWER MEASUREMENT

4.3.1 LIMITS OF PEAK TRANSMIT POWER MEASUREMENT

FREQUENCY BAND	LIMIT
5.150 ~ 5.250GHz	The lesser of 50mW (17dBm) or 4dBm + 10logB
5.250 ~ 5.350GHz	The lesser of 250mW (24dBm) or 11dBm + 10logB
5.470 ~ 5.725GHz	The lesser of 250mW (24dBm) or 11dBm + 10logB

NOTE: Where B is the 26dB emission bandwidth in MHz.

4.3.2 TEST SETUP

FOR POWER OUTPUT MEASUREMENT

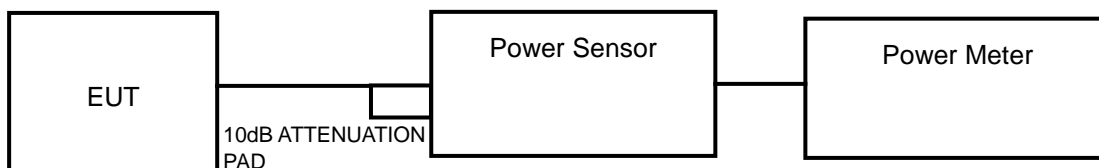

FOR 26dB BANDWIDTH

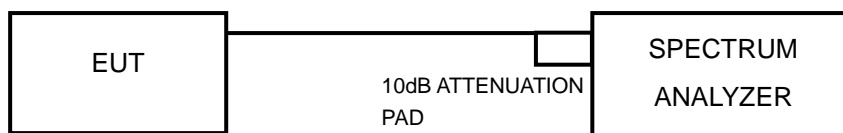

4.3.3 TEST INSTRUMENTS

Refer to section 4.1.3 to get information of above instrument.

4.3.4 TEST PROCEDURE

FOR AVERAGE POWER MEASUREMENT

<802.11a, 802.11n (20MHz), 802.11n (40MHz)>

Method PM is used to perform output power measurement, trigger and gating function of wide band power meter is enabled to measure max output power of TX on burst. Duty factor is added to measured value.

FOR 26dB BANDWIDTH

- 1) Set RBW = approximately 1% of the emission bandwidth.
- 2) Set the VBW > RBW.
- 3) Detector = Peak.
- 4) Trace mode = max hold.
- 5) Measure the maximum width of the emission that is 26 dB down from the peak of the emission. Compare this with the RBW setting of the analyzer. Readjust RBW and repeat measurement as needed until the RBW/EBW ratio is approximately 1%.

4.3.5 DEVIATION FROM TEST STANDARD

No deviation.

4.3.6 EUT OPERATING CONDITIONS

The software provided by client to enable the EUT under transmission condition continuously at specific channel frequencies individually.

4.3.7 TEST RESULTS

POWER OUTPUT:

MODE A

802.11a

CHANNEL	CHANNEL FREQUENCY (MHz)	AVERAGE POWER (mW)	AVERAGE POWER (dBm)	POWER LIMIT (dBm)	PASS/FAIL
36	5180	16.03	12.05	17	PASS
44	5220	17.10	12.33	17	PASS
48	5240	16.29	12.12	17	PASS

802.11n (20MHz)

CHANNEL	CHANNEL FREQUENCY (MHz)	AVERAGE POWER (mW)	AVERAGE POWER (dBm)	POWER LIMIT (dBm)	PASS/FAIL
36	5180	16.33	12.13	17	PASS
44	5220	16.94	12.29	17	PASS
48	5240	16.11	12.07	17	PASS

802.11n (40MHz)

CHANNEL	CHANNEL FREQUENCY (MHz)	AVERAGE POWER (mW)	AVERAGE POWER (dBm)	POWER LIMIT (dBm)	PASS/FAIL
38	5190	11.04	10.43	17	PASS
46	5230	10.38	10.16	17	PASS

**MODE B****802.11n (20MHz)**

CHAN.	CHAN. FREQ. (MHz)	AVERAGE POWER (dBm)		TOTAL POWER (mW)	TOTAL POWER (dBm)	POWER LIMIT (dBm)	PASS / FAIL
		CHAIN 0	CHAIN 1				
36	5180	7.53	9.22	14.02	11.47	15	PASS
40	5200	7.43	8.93	13.35	11.25	15	PASS
48	5240	7.58	8.63	13.02	11.15	15	PASS

NOTE: Directional gain = $5\text{dBi} + 10\log(2) = 8\text{dBi} > 6\text{dBi}$, so the power density limit shall be reduced to $17 - (8 - 6) = 15\text{dBm}$.

802.11n (40MHz)

CHAN.	CHAN. FREQ. (MHz)	AVERAGE POWER (dBm)		TOTAL POWER (mW)	TOTAL POWER (dBm)	POWER LIMIT (dBm)	PASS / FAIL
		CHAIN 0	CHAIN 1				
38	5190	6.31	7.78	10.27	10.12	15	PASS
46	5230	6.22	7.45	9.75	9.89	15	PASS

NOTE: Directional gain = $5\text{dBi} + 10\log(2) = 8\text{dBi} > 6\text{dBi}$, so the power density limit shall be reduced to $17 - (8 - 6) = 15\text{dBm}$.

26dB BANDWIDTH:**MODE A****802.11a**

CHANNEL	CHANNEL FREQUENCY (MHz)	26dBc BANDWIDTH (MHz)	PASS / FAIL
36	5180	22.73	PASS
44	5220	22.91	PASS
48	5240	23.52	PASS

802.11n (20MHz)

CHANNEL	CHANNEL FREQUENCY (MHz)	26dBc BANDWIDTH (MHz)	PASS / FAIL
36	5180	24.09	PASS
44	5220	23.92	PASS
48	5240	24.17	PASS

802.11n (40MHz)

CHANNEL	CHANNEL FREQUENCY (MHz)	26dBc BANDWIDTH (MHz)	PASS / FAIL
38	5190	50.15	PASS
46	5230	50.30	PASS



MODE B

802.11n (20MHz)

CHANNEL	CHANNEL FREQUENCY (MHz)	26dBc BANDWIDTH (MHz)		PASS / FAIL
		CHAIN 0	CHAIN 1	
36	5180	22.87	22.88	PASS
44	5220	22.97	22.19	PASS
48	5240	23.12	22.29	PASS

802.11n (40MHz)

CHANNEL	CHANNEL FREQUENCY (MHz)	26dBc BANDWIDTH (MHz)		PASS / FAIL
		CHAIN 0	CHAIN 1	
38	5190	48.78	47.48	PASS
46	5230	48.73	46.94	PASS

4.4 PEAK POWER SPECTRAL DENSITY MEASUREMENT

4.4.1 LIMITS OF PEAK POWER SPECTRAL DENSITY MEASUREMENT

FREQUENCY BAND	LIMIT
5.150 ~ 5.250GHz	4dBm
5.250 ~ 5.350GHz	11dBm
5.470 ~ 5.725GHz	11dBm

4.4.2 TEST SETUP

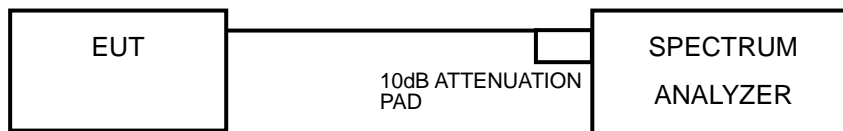

4.4.3 TEST INSTRUMENTS

Refer to section 4.1.3 to get information of above instrument.

4.4.4 TEST PROCEDURES

<802.11a, 802.11n (20MHz), 802.11n (40MHz)>

Using method SA-2 alternative

- 1) Set span to encompass the entire emission bandwidth (EBW) of the signal.
- 2) Set RBW = 1 MHz, Set VBW \geq 3 MHz, Detector = RMS
- 3) Sweep time = 4second.
- 4) Perform a single sweep.
- 5) Record the max value and add 10 log (1/duty cycle)

4.4.5 DEVIATION FROM TEST STANDARD

No deviation.

4.4.6 EUT OPERATING CONDITIONS

Same as 4.3.6.



4.4.7 TEST RESULTS

MODE A

802.11a

CHANNEL	FREQUENCY (MHz)	PSD W/O DUTY FACTOR (dBm)	DUTY FACTOR	PSD WITH DUTY FACTOR (dBm)	MAXIMUM LIMIT (dBm)	PASS/FAIL
36	5180	-0.39	0.2	-0.19	4	PASS
44	5220	-0.15	0.2	0.05	4	PASS
48	5240	-0.37	0.2	-0.17	4	PASS

NOTE: Refer to section 3.3 for duty cycle spectrum plot.

802.11n (20MHz)

CHANNEL	FREQUENCY (MHz)	PSD W/O DUTY FACTOR (dBm)	DUTY FACTOR	PSD WITH DUTY FACTOR (dBm)	MAXIMUM LIMIT (dBm)	PASS/FAIL
36	5180	-1.54	0.24	-1.30	4	PASS
44	5220	-0.89	0.24	-0.65	4	PASS
48	5240	-0.56	0.24	-0.32	4	PASS

NOTE: Refer to section 3.3 for duty cycle spectrum plot.

802.11n (40MHz)

CHANNEL	FREQUENCY (MHz)	PSD W/O DUTY FACTOR (dBm)	DUTY FACTOR	PSD WITH DUTY FACTOR (dBm)	MAXIMUM LIMIT (dBm)	PASS/FAIL
38	5190	-6.68	0.44	-6.24	4	PASS
46	5230	-6.44	0.44	-6.00	4	PASS

NOTE: Refer to section 3.3 for duty cycle spectrum plot.



MODE B

802.11n (20MHz)

CHANNEL	FREQUENCY (MHz)	PSD W/O DUTY FACTOR (dBm)		DUTY FACTOR	PSD WITH DUTY FACTOR (dBm)		TOTAL PSD WITH DUTY FACTOR (dBm)	MAXIMUM LIMIT (dBm)	PASS/FAIL
		CHAIN 0	CHAIN 1		CHAIN 0	CHAIN 1			
36	5180	-5.37	-3.24	0.38	-4.99	-2.86	-0.79	2	PASS
44	5220	-4.77	-3.34	0.38	-4.39	-2.96	-0.61	2	PASS
48	5240	-4.93	-3.84	0.38	-4.55	-3.46	-0.96	2	PASS

NOTE: Directional gain = 5dBi + 10log(2) = 8dBi > 6dBi , so the power density limit shall be reduced to 4-(8-6) = 2dBm.

802.11n (40MHz)

CHANNEL	FREQUENCY (MHz)	PSD W/O DUTY FACTOR (dBm)		DUTY FACTOR	PSD WITH DUTY FACTOR (dBm)		TOTAL PSD WITH DUTY FACTOR (dBm)	MAXIMUM LIMIT (dBm)	PASS/FAIL
		CHAIN 0	CHAIN 1		CHAIN 0	CHAIN 1			
38	5190	-9.37	-7.71	0.43	-8.94	-7.28	-5.02	2	PASS
46	5230	-9.22	-7.69	0.43	-8.79	-7.26	-4.95	2	PASS

NOTE: Directional gain = 5dBi + 10log(2) = 8dBi > 6dBi , so the power density limit shall be reduced to 4-(8-6) = 2dBm.

4.5 PEAK POWER EXCURSION MEASUREMENT

4.5.1 LIMITS OF PEAK POWER EXCURSION MEASUREMENT

Shall not exceed 13 dB.

4.5.2 TEST SETUP

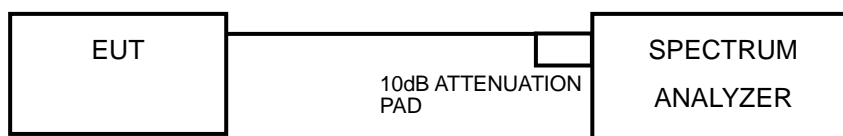

4.5.3 TEST INSTRUMENTS

Refer to section 4.1.3 to get information of above instrument.

4.5.4 TEST PROCEDURE

- 1) Set RBW = 1 MHz, VBW \geq 3 MHz, Detector = peak.
- 2) Trace mode = max-hold. Allow the sweeps to continue until the trace stabilizes.
- 3) Use the peak search function to find the peak of the spectrum.
- 4) Measure the PPSD.
- 5) Compute the ratio of the maximum of the peak-max-hold spectrum to the PPSD.

4.5.5 DEVIATION FROM TEST STANDARD

No deviation.

4.5.6 EUT OPERATING CONDITIONS

Same as 4.2.6



4.5.7 TEST RESULTS

MODE A

MODULATION MODE	MODULATION TYPE	CHAN. FREQ. (MHz)	PEAK VALUE (dBm)	PPSD WITHOUT DUTY FACTOR (dBm)	PPSD WITH DUTY FACTOR (dBm)	PEAK EXCURSION (dB)	LIMIT (dB)	PASS /FAIL
802.11a	BPSK	5220	9.11	-0.15	0.05	9.06	13	PASS
	QPSK		10.05	-0.12	0.23	9.82	13	PASS
	16QAM		10.04	-0.22	0.45	9.59	13	PASS
	64QAM		10.30	-0.68	0.43	9.87	13	PASS
802.11n (20MHz)	BPSK	5220	8.45	-0.89	-0.65	9.10	13	PASS
	QPSK		9.12	-0.84	-0.43	9.55	13	PASS
	16QAM		9.31	-1.10	-0.46	9.77	13	PASS
	64QAM		9.86	-1.19	-0.09	9.95	13	PASS
802.11n (40MHz)	BPSK	5190	2.95	-6.68	-6.24	9.19	13	PASS
	QPSK		3.21	-6.47	-5.61	8.82	13	PASS
	16QAM		3.25	-7.09	-6.19	9.44	13	PASS
	64QAM		2.95	-6.68	-6.24	9.19	13	PASS

NOTE: Refer to section 3.3 for duty cycle spectrum plot.

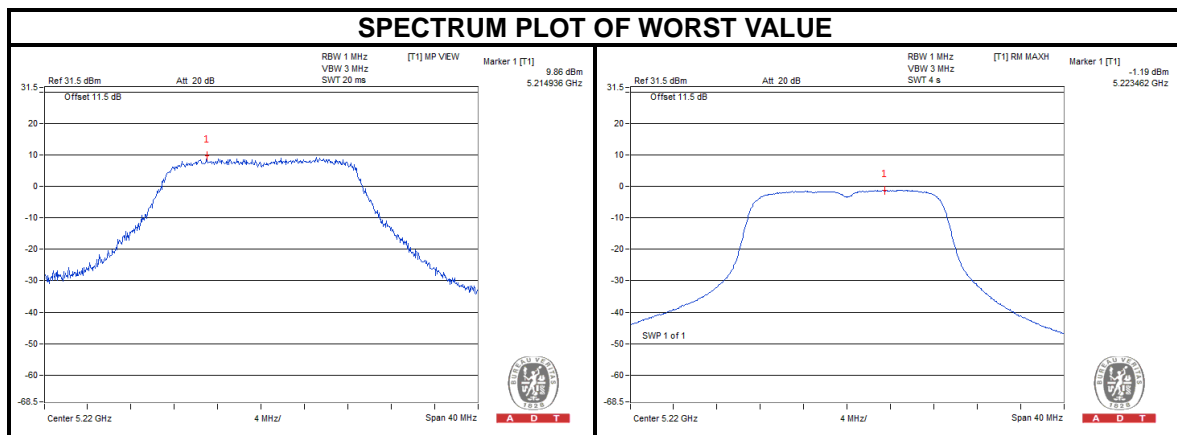



MODE B

802.11n (20MHz)

Modulation Mode	Modulation type	Channel Frequency (MHz)	PEAK VALUE (dBm)		PPSD WITHOUT DUTY FACTOR (dBm)		PPSD WITH DUTY FACTOR (dBm)	
			CHAIN0	CHAIN1	CHAIN0	CHAIN1	CHAIN0	CHAIN1
HT 20	BPSK	5220	4.98	6.11	-5.37	-3.24	-4.99	-2.86
	QPSK		5.81	6.91	-5.60	-3.27	-4.95	-2.62
	16QAM		5.04	7.91	-5.63	-4.15	-4.57	-3.09
	64QAM		5.51	6.90	-6.00	-4.20	-4.32	-2.52

PEAK Excursion (dB)		LIMIT (dB)	PASS /FAIL
CHAIN0	CHAIN1		
9.97	8.97	13	PASS
10.76	9.53	13	PASS
9.61	11.00	13	PASS
9.83	9.42	13	PASS

NOTE: Refer to section 3.3 for duty cycle spectrum plot.

802.11n (40MHz)

Modulation Mode	Modulation type	Channel Frequency (MHz)	PEAK VALUE (dBm)		PPSD WITHOUT DUTY FACTOR (dBm)		PPSD WITH DUTY FACTOR (dBm)	
			CHAIN0	CHAIN1	CHAIN0	CHAIN1	CHAIN0	CHAIN1
HT 40	BPSK	5190	0.72	3.05	-9.37	-7.71	-8.94	-7.28
	QPSK		1.17	3.08	-9.53	-7.86	-8.90	-7.23
	16QAM		0.65	3.03	-9.91	-7.88	-8.86	-6.83
	64QAM		1.29	2.69	-10.07	-7.97	-8.61	-6.51

PEAK Excursion (dB)		LIMIT (dB)	PASS /FAIL
CHAIN0	CHAIN1		
9.66	10.33	13	PASS
10.07	10.31	13	PASS
9.51	9.86	13	PASS
9.90	9.20	13	PASS

NOTE: Refer to section 3.3 for duty cycle spectrum plot.



A D T

SPECTRUM PLOT OF WORST VALUE

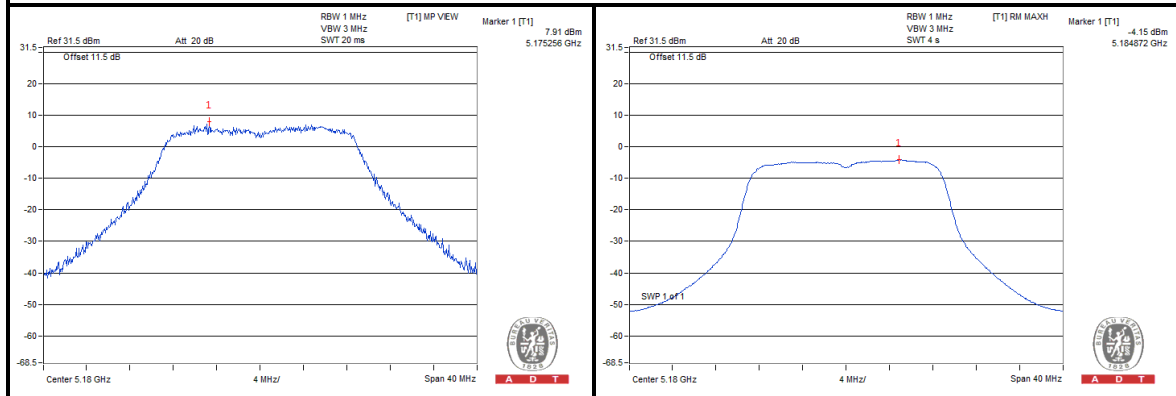

4.6 FREQUENCY STABILITY

4.6.1 LIMITS OF FREQUENCY STABILITY MEASUREMENT

The frequency of the carrier signal shall be maintained within band of operation

4.6.2 TEST SETUP

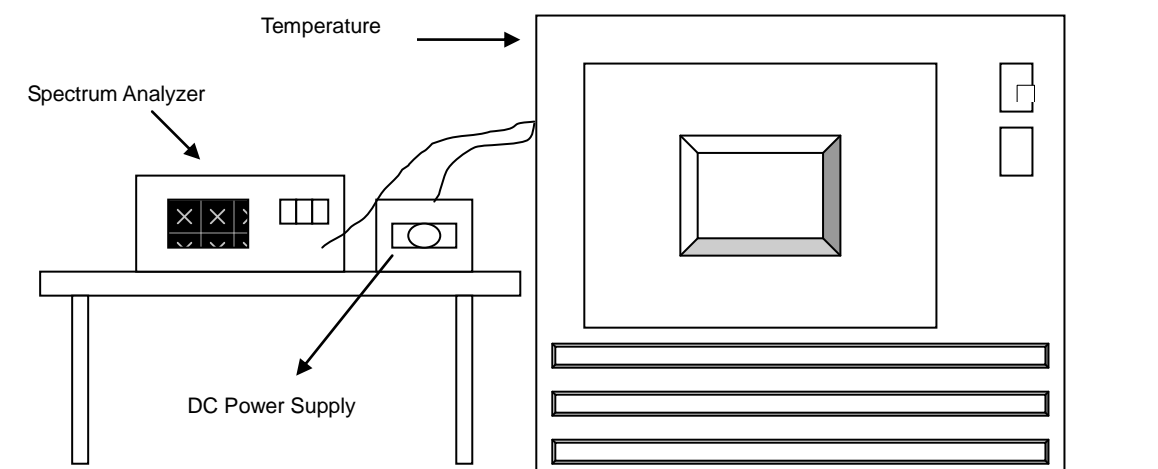

4.6.3 TEST INSTRUMENTS

Refer to section 4.1.3 to get information of above instrument.

4.6.4 TEST PROCEDURE

- a. To ensure emission at the band edge is maintained within the authorized band, those values shall be measured by radiation emissions at upper and lower frequency points, and finally compensated by frequency deviation as procedures below.
- b. The EUT was operated at the maximum output power, and connected to the spectrum analyzer, which is set to maximum hold function and peak detector. The peak value of the power envelope was measured and noted. The upper and lower frequency points were respectively measured relatively 10dB lower than the measured peak value.
- c. The frequency deviation was calculated by adding the upper frequency point and the lower frequency point divided by two. Those detailed values of frequency deviation are provided in table below.

4.6.5 DEVIATION FROM TEST STANDARD

No deviation.

4.6.6 EUT OPERATING CONDITION

Set the EUT transmit at un-modulation mode to test frequency stability.

4.6.7 TEST RESULTS

FREQUENCY STABILITY VERSUS TEMP.									
OPERATING FREQUENCY: 5320MHz									
TEMP. (°C)	POWER SUPPLY (Vdc)	0 MINUTE		2 MINUTE		5 MINUTE		10 MINUTE	
		Measured Frequency (MHz)	Frequency Drift (ppm)	Measured Frequency (MHz)	Frequency Drift (ppm)	Measured Frequency (MHz)	Frequency Drift (ppm)	Measured Frequency (MHz)	Frequency Drift (ppm)
50	8.0	5180.041102	-3838.250	5180.041093	-3838.251	5180.041451	-3838.182	5180.041646	-3838.145
40	8.0	5180.041781	-3838.119	5180.041521	-3838.169	5180.041811	-3838.113	5180.042195	-3838.039
30	8.0	5180.042941	-3837.896	5180.042817	-3837.920	5180.042881	-3837.907	5180.042981	-3837.888
20	8.0	5180.043918	-3837.708	5180.044525	-3837.591	5180.044147	-3837.664	5180.044306	-3837.633
10	8.0	5180.045332	-3837.436	5180.045570	-3837.390	5180.045541	-3837.396	5180.045314	-3837.440
0	8.0	5180.044209	-3837.652	5180.043738	-3837.743	5180.044223	-3837.649	5180.044186	-3837.657
-10	8.0	5180.042587	-3837.964	5180.042419	-3837.996	5180.042686	-3837.945	5180.042636	-3837.955
-20	8.0	5180.041767	-3838.122	5180.042134	-3838.051	5180.041949	-3838.087	5180.042474	-3837.986
-30	8.0	5180.040779	-3838.312	5180.041186	-3838.233	5180.041005	-3838.268	5180.040931	-3838.282

FREQUENCY STABILITY VERSUS VOLTAGE									
OPERATING FREQUENCY: 5320MHz									
TEMP. (°C)	POWER SUPPLY (Vac)	0 MINUTE		2 MINUTE		5 MINUTE		10 MINUTE	
		Measured Frequency (MHz)	Frequency Drift (ppm)	Measured Frequency (MHz)	Frequency Drift (ppm)	Measured Frequency (MHz)	Frequency Drift (ppm)	Measured Frequency (MHz)	Frequency Drift (ppm)
20	8.0	5320.044797	23085.538	5320.044659	23085.511	5320.044744	23085.528	5320.044360	23085.454
	12.0	5320.044906	23085.559	5320.045340	23085.642	5320.045206	23085.617	5320.044954	23085.568
	18.00	5320.046467	23085.859	5320.046743	23085.912	5320.046255	23085.818	5320.046572	23085.879

5. PHOTOGRAPHS OF THE TEST CONFIGURATION

Please refer to the attached file (Test Setup Photo).



6. INFORMATION ON THE TESTING LABORATORIES

We, Bureau Veritas Consumer Products Services (H.K.) Ltd., Taoyuan Branch, were founded in 1988 to provide our best service in EMC, Radio, Telecom and Safety consultation. Our laboratories are accredited and approved according to ISO/IEC 17025.

If you have any comments, please feel free to contact us at the following:

Linko EMC/RF Lab:

Tel: 886-2-26052180

Fax: 886-2-26051924

Hsin Chu EMC/RF Lab:

Tel: 886-3-5935343

Fax: 886-3-5935342

Hwa Ya EMC/RF/Safety Telecom Lab:

Tel: 886-3-3183232

Fax: 886-3-3270892

Email: service.adt@tw.bureauveritas.com

Web Site: www.bureauveritas-adt.com

The address and road map of all our labs can be found in our web site also.

7. APPENDIX A - MODIFICATIONS RECORDERS FOR ENGINEERING CHANGES TO THE EUT BY THE LAB

No modifications were made to the EUT by the lab during the test.

---END---