

**ELECTROMAGNETIC EMISSIONS COMPLIANCE REPORT
INTENTIONAL RADIATOR CERTIFICATION TO
FCC PART 15 SUBPART C
REQUIREMENT T**

OF

Wireless wind-sun sensor

MODEL No.: DC116

Trademark: N/A

FCC ID: VYY-DC116

REPORT NO: ES151123028E

ISSUE DATE: January 12, 2016

Prepared for

NINGBO DOOYA MECHANIC & ELECTRONIC TECHNOLOGY CO., LTD.

Loutou Industrial Area, Zhenhai, Ningbo, Zhejiang, China

Prepared by

EMTEK (SHENZHEN) CO., LTD

Bldg 69, Majialong Industry Zone, Nanshan District,
Shenzhen, Guangdong, China

TEL: 86-755-26954280

FAX: 86-755-26954282

VERIFICATION OF COMPLIANCE

Applicant	:	NINGBO DOOYA MECHANIC & ELECTRONIC TECHNOLOGY CO., LTD. Loutou Industrial Area, Zhenhai, Ningbo, Zhejiang, China
Manufacturer	:	NINGBO DOOYA MECHANIC & ELECTRONIC TECHNOLOGY CO., LTD. Loutou Industrial Area, Zhenhai, Ningbo, Zhejiang, China
Product Description	:	Wireless wind-sun sensor
Model Number	:	DC116
Serial Number	:	N/A
File Number	:	ES151123028E
Date of Test	:	November 24, 2015 to January 12, 2016

We hereby certify that:

The above equipment was tested by EMTEK (SHENZHEN) CO., LTD. The test data, data evaluation, test procedures, and equipment configurations shown in this report were made in accordance with the procedures given in ANSI C63.10 (2013) and the energy emitted by the sample EUT tested as described in this report is in compliance with radiated emission limits of FCC Rules Part 15.231(2015).

The test results of this report relate only to the tested sample identified in this report.

Date of Test : November 24, 2015 to January 12, 2016

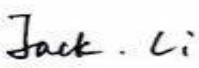
Prepared by : 
Jack Li/Editor

Reviewer : 
Joe Xia/Supervisor

Approve & Authorized Signer : 
Lisa Wang/Manager

TABLE OF CONTENTS

1.	GENERAL INFORMATION	5
1.1.	PRODUCT DESCRIPTION.....	5
1.2.	RELATED SUBMITTAL(S) / GRANT (S)	5
1.3.	TEST METHODOLOGY	5
1.4.	SPECIAL ACCESSORIES.....	5
1.5.	EQUIPMENT MODIFICATIONS.....	5
1.6.	MEASUREMENT UNCERTAINTY	6
1.7.	TEST FACILITY	6
2.	SYSTEM TEST CONFIGURATION.....	7
2.1.	EUT CONFIGURATION	7
2.2.	EUT EXERCISE	7
2.3.	TEST PROCEDURE.....	7
2.4.	DESCRIPTION OF TEST MODES.....	7
2.5.	SUMMARY OF TEST RESULTS	7
2.6.	DESCRIPTION OF SUPPORT UNITS	7
3.	CONDUCTED EMISSIONS TEST	8
3.1.	MEASUREMENT PROCEDURE:.....	8
3.2.	TEST SET-UP (BLOCK DIAGRAM OF CONFIGURATION).....	8
3.3.	MEASUREMENT EQUIPMENT USED:.....	8
3.4.	CONDUCTED EMISSION LIMIT.....	8
3.5.	MEASUREMENT RESULT:.....	9
4.	RADIATED EMISSION TEST.....	11
4.1.	MEASUREMENT PROCEDURE.....	11
4.2.	TEST SET-UP (BLOCK DIAGRAM OF CONFIGURATION).....	11
4.3.	MEASUREMENT EQUIPMENT USED:.....	12
4.4.	RADIATED EMISSION LIMIT	13
4.5.	CALCULATION OF AVERAGE FACTOR.....	14
4.6.	MEASUREMENT RESULT.....	18
5.	TRANSMISSION REQUIREMENT	20
5.1.	REQUIREMENT	20
5.2.	TEST SET-UP.....	20
5.3.	MEASUREMENT EQUIPMENT USED:.....	20
5.4.	TEST PROCEDURE	20
5.5.	TEST DATA	21
6.	BANDWIDTH TEST	22
6.1.	MEASUREMENT PROCEDURE.....	22
6.2.	TEST SET-UP (BLOCK DIAGRAM OF CONFIGURATION).....	22
6.3.	MEASUREMENT EQUIPMENT USED:.....	22
6.4.	MEASUREMENT RESULTS:	22

7. ANTENNA APPLICATION..... 24

7.1. ANTENNA REQUIREMENT24

7.2. RESULT24

1. GENERAL INFORMATION

1.1. Product Description

Emitter (referred to as the EUT in this report), it is designed by way of utilizing the OOK modulation achieves the system operating.

A major technical descriptions of EUT is described as following:

- A). Operation Frequency: 433.9134MHz
- B). Modulation: OOK
- C). Antenna Type: PCB antenna
- D). Antenna Gain: < 1dBi
- E). Power Supply: AC 120V 60Hz

1.2. Related Submittal(s) / Grant (s)

This submittal(s) (test report) is intended for FCC ID: VYY-DC116 filing to comply with Section 15.231 of the FCC Part 15, Subpart C Rules.

1.3. Test Methodology

The radiated testing was performed according to the procedures in ANSI C63.10 (2013). Radiated testing was performed at an antenna to EUT distance 3 meters.

1.4. Special Accessories

Not available for this EUT intended for grant.

1.5. Equipment Modifications

Not available for this EUT intended for grant.

1.6. Measurement Uncertainty

Measurement Type	Range	Confidence Level (%)	Calculated Uncertainty
Fundamental Fieldstrength	Not Applicable	95%	±2.94dB
Transmitter 20 dB Bandwidth	Not Applicable	95%	±0.92PPm
Radiated Spurious Emissions	30 MHz to 40 GHz	95%	±3.00dB
Conducted Emission	0.15MHz to 0.50MHz	95%	±2.0dB

1.7. Test Facility

Site Description

EMC Lab.

: Accredited by CNAS, 2013.10.29
 The certificate is valid until 2016.10.28
 The Laboratory has been assessed and proved to be in compliance with
 CNAS/CL01:2006(identical to ISO/IEC17025: 2005)
 The Certificate Registration Number is L2291

Accredited by TUV Rheinland Shenzhen 2010.5.25
 The Laboratory has been assessed according to the requirements ISO/IEC
 17025

Accredited by FCC, April 17, 2014
 The Certificate Registration Number is 406365.

Accredited by Industry Canada, March 5, 2010
 The Certificate Registration Number is 4480A-2.

Name of Firm

: EMTEK (SHENZHEN) CO., LTD.

Site Location

: Bldg 69, Majialong Industry Zone,
 Nanshan District, Shenzhen, Guangdong, China

2. SYSTEM TEST CONFIGURATION

2.1. EUT Configuration

The EUT configuration for testing is installed on RF field strength measurement to meet the Commissions requirement and operating in a manner which intends to maximize its emission characteristics in a continuous normal application.

2.2. EUT Exercise

The Transmitter was operated in the normal operating mode. The TX frequency was fixed which was for the purpose of the measurements.

2.3. Test Procedure

2.3.1 Radiated Emissions

The EUT is placed on a turn table which is 0.8 m above ground plane. The turn table shall rotate 360 degrees to determine the position of maximum emission level. EUT is set 3m away from the receiving antenna which varied from 1m to 4m to find out the highest emission. And also, each emission was to be maximized by changing the polarization of receiving antenna both horizontal and vertical. In order to find out the max. Emission, the relative positions of this hand-held transmitter (EUT) was rotated through three orthogonal axes according to the requirements in Section 6.3 to 6.6 of ANSI C63.10-2013.

2.4. Description of test modes

The EUT (Wireless wind-sun sensor) has been tested under normal operating condition. Let EUT transmit during test, and the result was reported.

2.5. Summary of Test Results

FCC Part15, Subpart C		
Standard Section	Test Item	Result
FCC		
15.231(a)(1)	Transmission Requirement	Pass
15.231(b)	Radiated Emission	Pass
15.231(c)	20dB Bandwidth	Pass
15.207(a)	Conducted Emission	Pass

Note: (1)"N/A" denotes test is not applicable in this test report.

2.6. Description of Support Units

Equipment	Mfr/Brand	Model/Type No.	FCC ID / IC	Series No.	Note
Wireless wind-sun sensor	N/A	DC115A	VYY-DC116	N/A	EUT

3. Conducted Emissions Test

3.1. Measurement Procedure:

1. The EUT was placed on a table which is 0.8m above ground plane.
2. Maximum procedure was performed on the six highest emissions to ensure EUT compliance.
3. Repeat above procedures until all frequency measured were complete.

3.2. Test SET-UP (Block Diagram of Configuration)

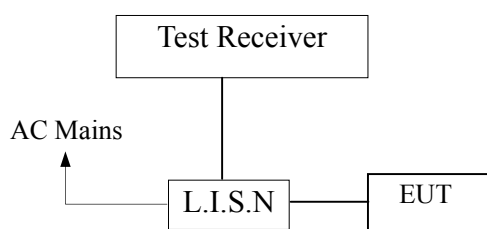

3.3. Measurement Equipment Used:

Conducted Emission Test Site					
EQUIPMENT TYPE	MFR	MODEL NUMBER	SERIAL NUMBER	LAST CAL.	CAL DUE.
Test Receiver	Rohde & Schwarz	ESCS30	828985/018	05/16/2015	05/15/2016
L.I.S.N	Rohde & Schwarz	ESH2-Z5	834549/005	05/16/2015	05/15/2016
50Ω Coaxial Switch	Anritsu	MP59B	M20531	05/16/2015	05/15/2016

3.4. Conducted Emission Limit

(7) Conducted Emission

Frequency(MHz)	Quasi-peak	Average
0.15-0.5	66-56	56-46
0.5-5.0	56	46
5.0-30.0	60	50

Note:

1. The lower limit shall apply at the transition frequencies
2. The limit decreases in line with the logarithm of the frequency in the range of 0.15 to 0.50MHz.

3.5.Measurement Result:

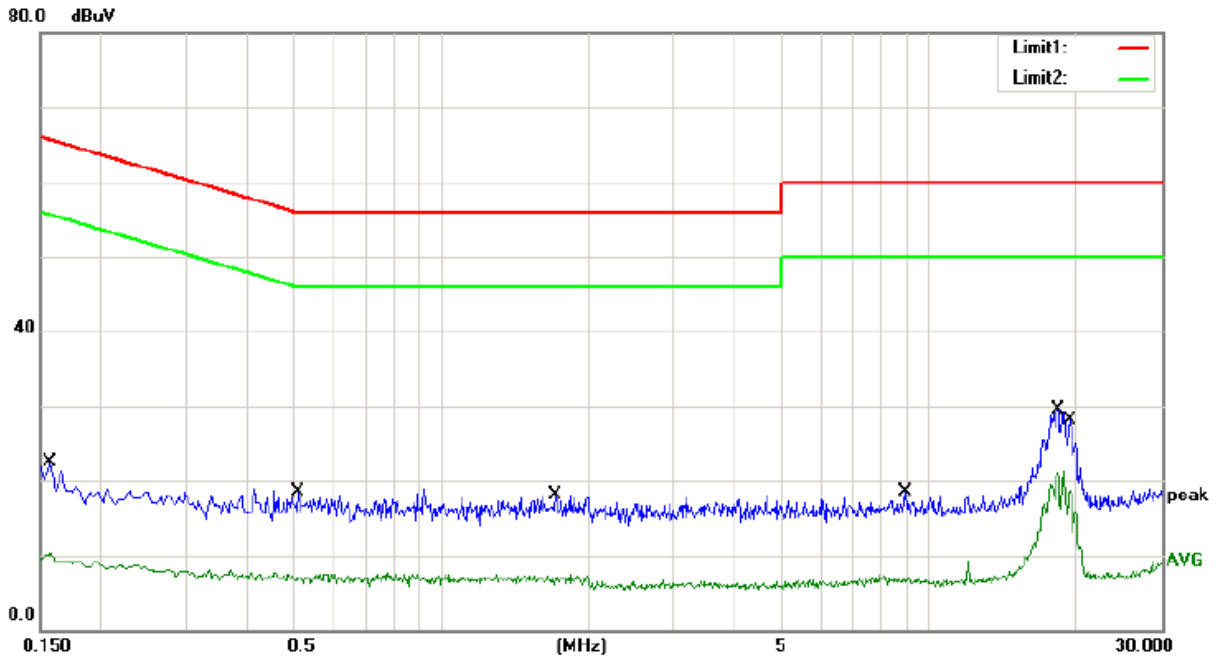

Site site #1 Phase: **L1** Temperature: 22
 Limit: (CE)FCC PART 15 class B_QP Power: AC 120V/60Hz Humidity: 50 %
 EUT: Wireless wind-sun sensor
 M/N: DC116
 Mode: ON
 Note:

No.	Mk.	Freq. MHz	Reading Level dBuV	Correct Factor dB	Measure- ment dBuV	Limit dBuV	Over dB	Detector	Comment
1		0.1580	11.40	11.00	22.40	65.57	-43.17	QP	
2		0.1580	-0.80	11.00	10.20	55.57	-45.37	AVG	
3		0.5100	7.50	11.00	18.50	56.00	-37.50	QP	
4		0.5100	-4.10	11.00	6.90	46.00	-39.10	AVG	
5		1.7100	7.00	11.00	18.00	56.00	-38.00	QP	
6		1.7100	-3.80	11.00	7.20	46.00	-38.80	AVG	
7		8.9200	7.50	11.00	18.50	60.00	-41.50	QP	
8		8.9200	-4.40	11.00	6.60	50.00	-43.40	AVG	
9		18.3320	18.50	11.00	29.50	60.00	-30.50	QP	
10	*	18.3320	10.10	11.00	21.10	50.00	-28.90	AVG	
11		19.4720	17.00	11.00	28.00	60.00	-32.00	QP	
12		19.4720	7.70	11.00	18.70	50.00	-31.30	AVG	

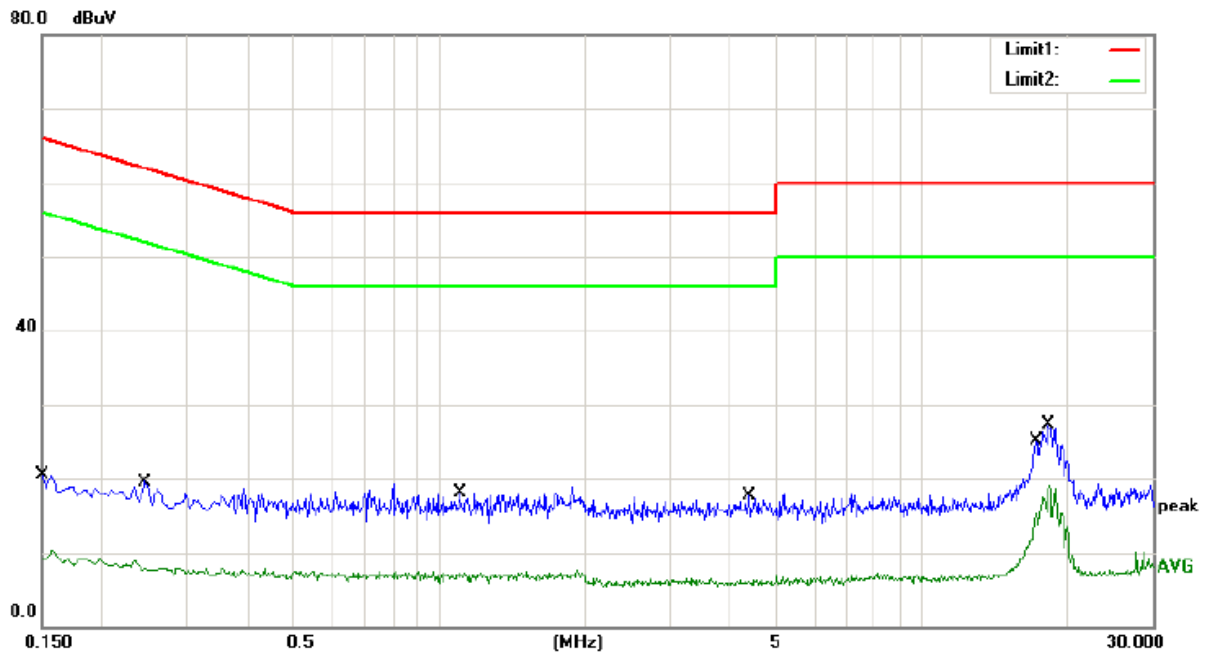

Site site #1 Phase: **N** Temperature: 22
 Limit: (CE)FCC PART 15 class B_QP Power: AC 120V/60Hz Humidity: 50 %
 EUT: Wireless wind-sun sensor
 M/N: DC116
 Mode: ON
 Note:

No.	Mk.	Freq. MHz	Reading Level dBuV	Correct Factor dB	Measure- ment dBuV	Limit dBuV	Over dB	Detector	Comment
1		0.1500	9.50	11.00	20.50	66.00	-45.50	QP	
2		0.1500	-1.70	11.00	9.30	56.00	-46.70	AVG	
3		0.2460	8.60	11.00	19.60	61.89	-42.29	QP	
4		0.2460	-3.10	11.00	7.90	51.89	-43.99	AVG	
5		1.1100	7.00	11.00	18.00	56.00	-38.00	QP	
6		1.1100	-4.20	11.00	6.80	46.00	-39.20	AVG	
7		4.3860	6.60	11.00	17.60	56.00	-38.40	QP	
8		4.3860	-4.90	11.00	6.10	46.00	-39.90	AVG	
9		17.2520	14.10	11.00	25.10	60.00	-34.90	QP	
10		17.2520	4.20	11.00	15.20	50.00	-34.80	AVG	
11		18.2840	16.30	11.00	27.30	60.00	-32.70	QP	
12	*	18.2840	7.20	11.00	18.20	50.00	-31.80	AVG	

4. RADIATED EMISSION TEST

4.1. Measurement Procedure

a. 9 kHz to 30 MHz emissions

For testing performed with the loop antenna. The centre of the loop was positioned 1 m above the ground and positioned with its plane vertical at the special distance from the EUT. During testing the loop was rotated about its vertical axis for maximum response at each azimuth and also investigated with the loop positioned in the horizontal plane.

b. 30 MHz to 1 GHz emissions:

For testing performed with the bi-log type antenna. The measurement is performed with the EUT rotated 360°, the antenna height scanned between 1m and 4m, and the antenna rotated to repeat the measurement for both the horizontal and vertical antenna polarizations.

c. Above 1 GHz emissions:

For testing performed with the horn antenna. The measurement is performed with the EUT rotated 360°, the antenna height scanned between 1m and 4m, and the antenna rotated to repeat the measurement for both the horizontal and vertical antenna polarizations.

Detector: For Peak:

RBW = 1 MHz for $f \geq 1$ GHz,

200 Hz for 9 kHz to 150 kHz

9 kHz for 150 kHz to 30 MHz

100 kHz for 30 MHz to 1GHz

VBW \geq RBW

Sweep = auto

Detector function = peak for $f \geq 1$ GHz, QP for $f < 1$ GHz

Trace = max hold

For AV value:

Average = Peak value + 20log (Duty cycle)

4.2. Test SET-UP (Block Diagram of Configuration)

a. Radiated Emission Test Set-Up, Frequency Below 30MHz

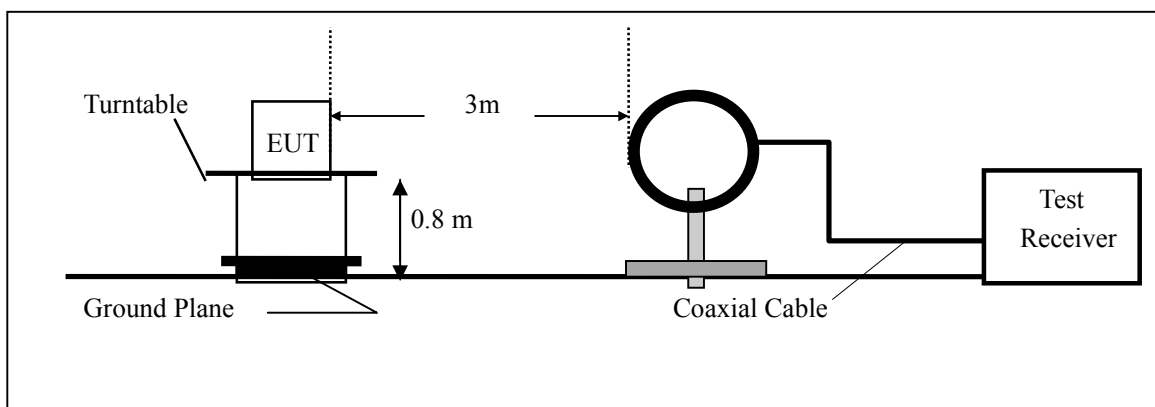

b. Radiated Emission Test Set-Up, Frequency Below 1000MHz

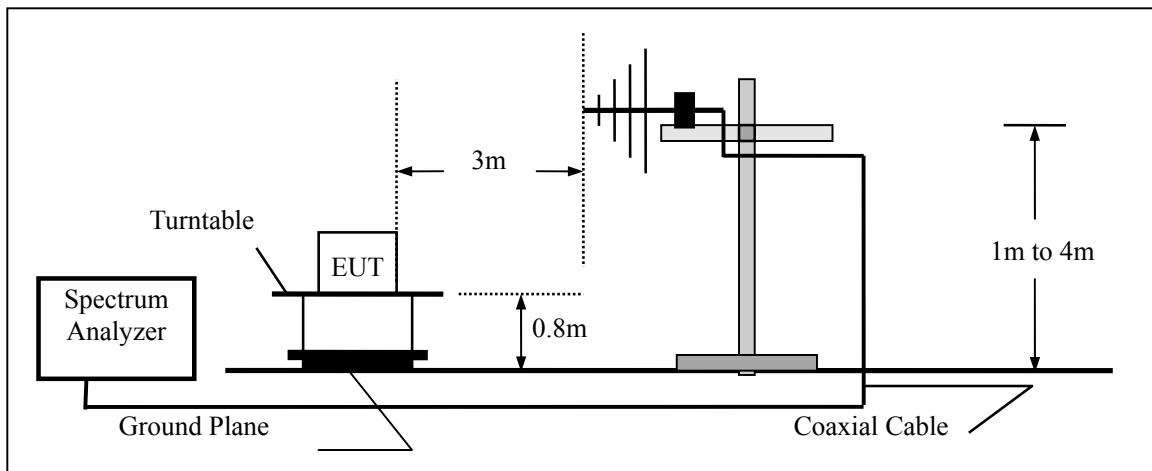

c. Radiated Emission Test Set-Up, Frequency above 1000MHz

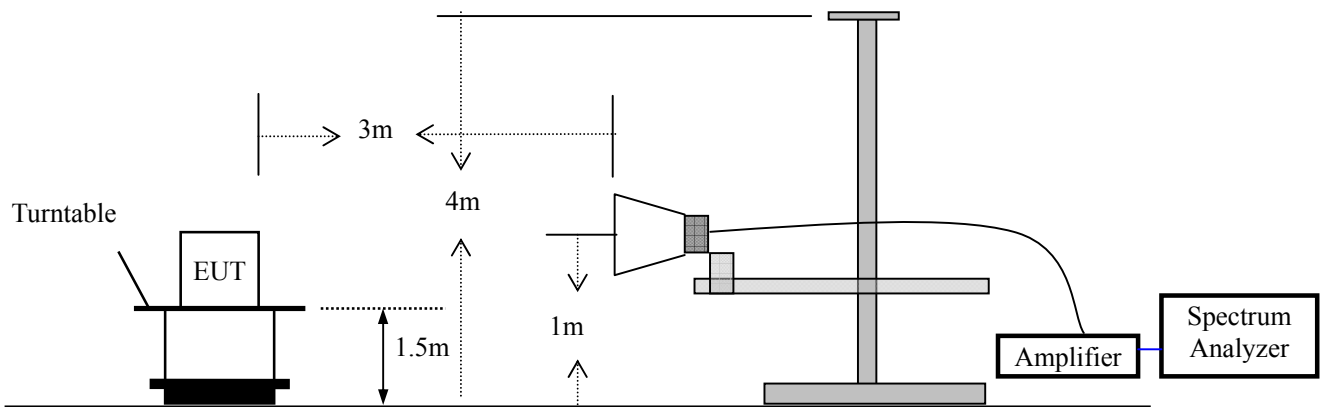

4.3. Measurement Equipment Used:

EQUIPMENT TYPE	MFR	MODEL NUMBER	SERIAL NUMBER	LAST CAL.	CAL DUE.
Spectrum Analyzer	Rohde & Schwarz	ESCI	10017	07/18/2015	07/07/2016
Spectrum Analyzer	Rohde & Schwarz	FSP7	839511/010	05/16/2015	05/15/2016
Spectrum Analyzer	HP	E4407B	839840481	05/16/2015	05/15/2016
EMI Test Receiver	Rohde & Schwarz	ESCS30	828985/018	05/16/2015	05/15/2016
Pre-Amplifier	HP	8447D	2944A07999	05/16/2015	05/15/2016
Bilog Antenna	Schwarzbeck	VULB9163	142	05/16/2015	05/15/2016
Loop Antenna	ARA	PLA-1030/B	1029	05/16/2015	05/15/2016
Horn Antenna	Schwarzbeck	BBHA 9170	BBHA9170399	05/16/2015	05/15/2016
Horn Antenna	Schwarzbeck	BBHA 9120	D143	05/16/2015	05/15/2016

4.4. Radiated Emission Limit

FCC 15.205 Restricted frequency band

MHz	MHz	MHz	GHz
0.090 - 0.110	16.42 - 16.423	399.9 - 410	4.5 - 5.15
¹ 0.495 - 0.505	16.69475 - 16.69525	608 - 614	5.35 - 5.46
2.1735 - 2.1905	16.80425 - 16.80475	960 - 1240	7.25 - 7.75
4.125 - 4.128	25.5 - 25.67	1300 - 1427	8.025 - 8.5
4.17725 - 4.17775	37.5 - 38.25	1435 - 1626.5	9.0 - 9.2
4.20725 - 4.20775	73 - 74.6	1645.5 - 1646.5	9.3 - 9.5
6.215 - 6.218	74.8 - 75.2	1660 - 1710	10.6 - 12.7
6.26775 - 6.26825	108 - 121.94	1718.8 - 1722.2	13.25 - 13.4
6.31175 - 6.31225	123 - 138	2200 - 2300	14.47 - 14.5
8.291 - 8.294	149.9 - 150.05	2310 - 2390	15.35 - 16.2
8.362 - 8.366	156.52475 - 156.52525	2483.5 - 2500	17.7 - 21.4
8.37625 - 8.38675	156.7 - 156.9	2690 - 2900	22.01 - 23.12
8.41425 - 8.41475	162.0125 - 167.17	3260 - 3267	23.6 - 24.0
12.29 - 12.293	167.72 - 173.2	3332 - 3339	31.2 - 31.8
12.51975 - 12.52025	240 - 285	3345.8 - 3358	36.43 - 36.5
12.57675 - 12.57725	322 - 335.4	3600 - 4400	(²)

FCC 15.209 Limited

Frequencies (MHz)	Field Strength (micorvolts/meter)	Measurement Distance (meters)
0.009~0.490	2400/F(KHz)	300
0.490~1.705	24000/F(KHz)	30
1.705~30.0	30	30
30~88	100	3
88~216	150	3
216~960	200	3
960~1000	500	3
Above 1GHz	74 dBuV/m (PEAK) 54 dBuV/m (AVERAGE)	

15.231 Limited

Fundamental Frequency (MHz)	Field Strength of Fundamental (microvolts/meter)	Field Strength of Spurious Emissions (microvolts/meter)
40.66 - 40.70	2,250	225
70 - 130	1,250	125
130 - 174	1,250 to 3,750 **	125 to 375 **
174 - 260	3,750	375
260 - 470	3,750 to 12,500 **	375 to 1,250 **
Above 470	12,500	1,250

** linear interpolations

[Where F is the frequency in MHz, the formulas for calculating the maximum permitted fundamental field strengths are as follows: for the band 130-174 MHz, uV/m at 3 meters = 56.81818(F) - 6136.3636; for the band 260-470 MHz, uV/m at 3 meters = 41.6667(F) - 7083.3333. The maximum permitted unwanted emission level is 20 dB below the maximum permitted fundamental level.]

The fundamental frequency of the EUT is 433.9134MHz

The limit for average field strength dBuV/m for the fundamental emission= 80.82 dBuV/m

No fundamental is allowed in the restricted bands.

Spurious Emissions do not fall in the restricted bands must be less than 60.82 dBuV/m or limits shown in Section 15.209, whichever limit permits a higher field strength.

Spurious Emissions appear within the restricted bands shall not exceed the limits shown in Section 15.209.

FCC Part15 (15.231) , Subpart C		
Fundamental Frequency	Field Strength Of Fundamental	Field Strength of Spurious Emissions
433.9134 MHz	AV:80.82 dBuV/m at 3m distance	AV:60.82 dBuV/m at 3m distance
	PK:100.82dBuV/m at 3m distance	PK:80.82 dBuV/m at 3m distance

4.5. Calculation of Average factor

The output field strengths of specification in accordance with the FCC rules specify measurements with an average detector. During the test, a spectrum analyzer incorporating a peak detector was used. Therefore, a reduction factor can be applied to the resultant peak signal level and compared to the limit for measurement instrumentation incorporating an average detector.

The duty cycle is measured in 100ms or the repetition cycle period, whichever is a shorter time frame, the duty cycle is measured by placing the spectrum analyzer to set zero span at 100kHz resolution bandwidth.

Averaging factor in dB=20log(duty cycle)

Where the duty factor is calculated from following formula:

$$20\log(\text{Duty cycle})=20\log((4.8+0.78*12+0.42*28)/49.9)=-5.69\text{dB}$$

Therefore, the averaging factor is -5.691dB.

Pulse Width(PW)=0.42, 2/PW=2/0.4=4.76KHz, RBW=100KHz>4.76KHz, Therefore PDCF is not needed.

Please see the diagrams below:

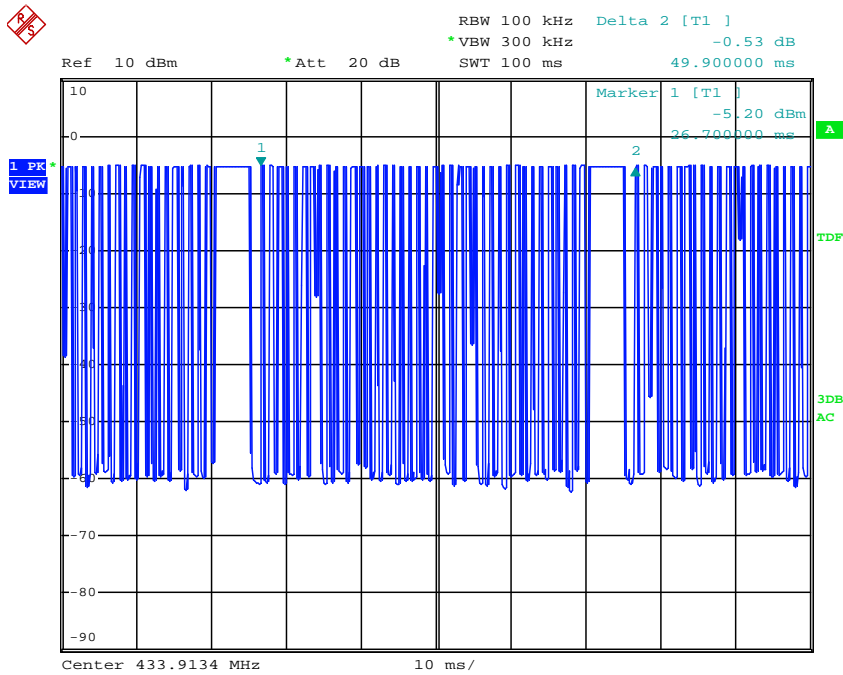

Date: 12.JAN.2016 14:43:13

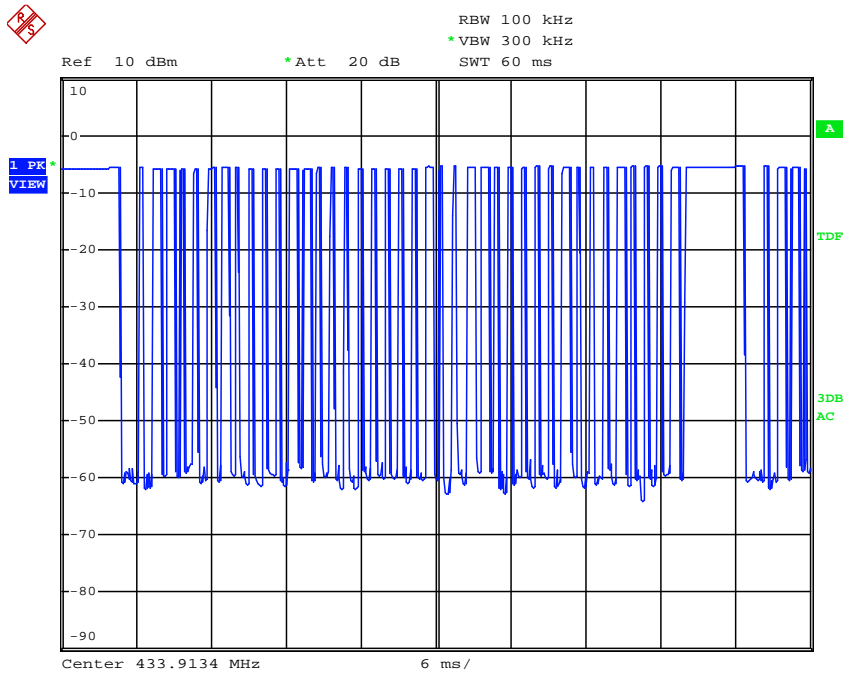

Date: 12.JAN.2016 14:44:48

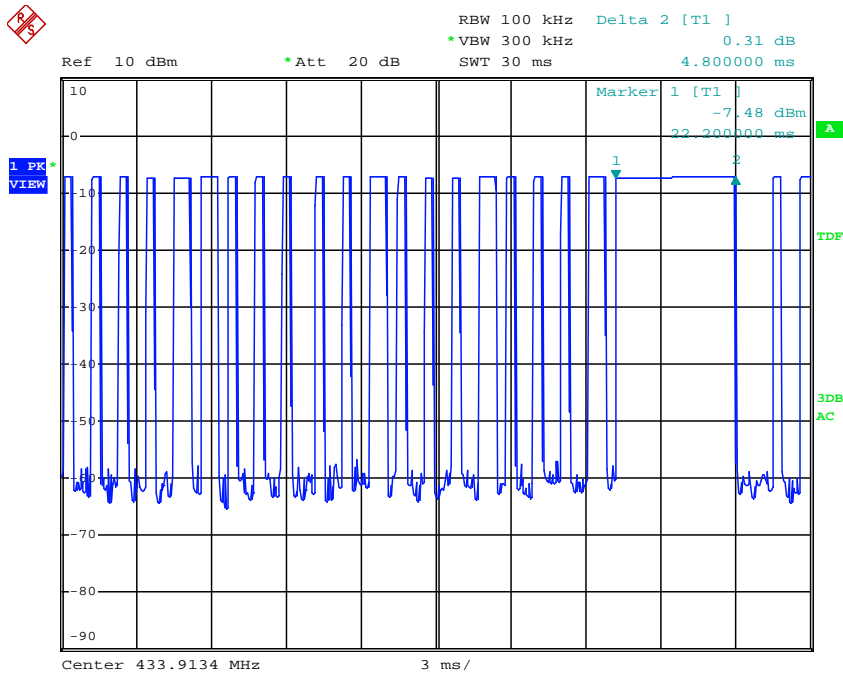

Date: 12.JAN.2016 14:47:20

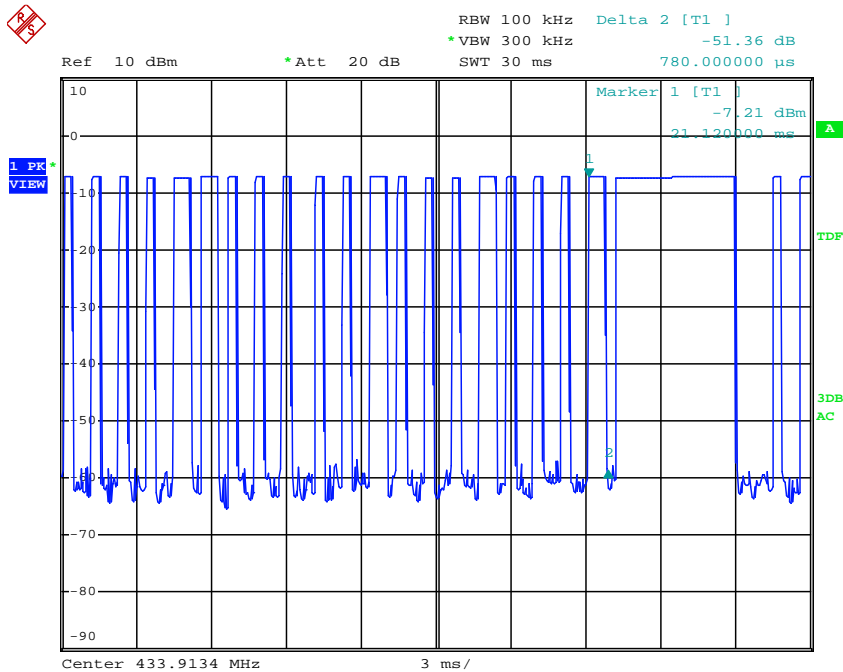

Date: 12.JAN.2016 14:47:45

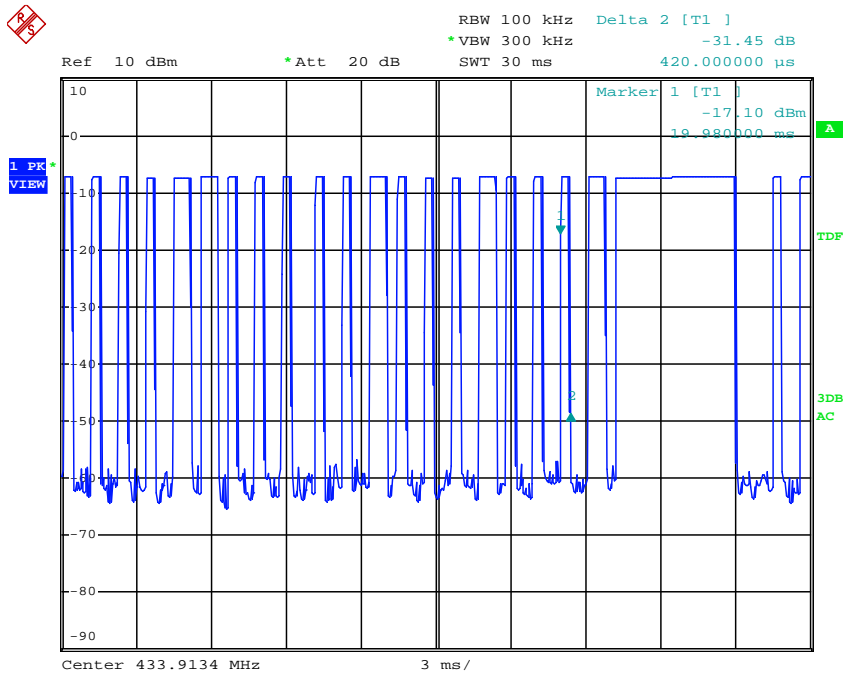

Date: 12.JAN.2016 14:48:02

4.6. Measurement Result

1. Fundamental emission:

Antenna polarization: Horizontal:

Freq. (MHz)	Reading Level(dBuV)	Correct Factor(dB)	Level (dBuV/m)	Limit Line (dBuV/m)	Margin (dB)	Remark
433.9134	101.51	-16.78	84.73	100.82	-16.09	Peak
433.9134	84.73	-5.69	79.04	80.82	-1.78	Average

Antenna polarization: Vertical

Freq. (MHz)	Reading Level(dBuV)	Correct Factor(dB)	Level (dBuV/m)	Limit Line (dBuV/m)	Margin (dB)	Remark
433.9134	94.52	-16.78	77.74	100.82	-23.08	Peak
433.9134	77.74	-5.69	72.05	80.82	-8.77	Average

2. Other emissions

The receiver was scanned from the lowest frequency generated within the EUT to 4.5 GHz. The field strength is calculated by adding the Antenna Factor, Cable Factor & Peramplifier.

The basic equation with a sample calculation is as follows:

Final Test Level = Receiver Reading + Antenna Factor + Cable Factor – Peramplifier Factor.

All the x/y/z orientation has been investigated, and only worst case is presented in this report.

The following test results were performed on the EUT.

Horizontal:

Freq. (MHz)	Reading Level(dBuV)	Correct Factor(dB)	Level (dBuV/m)	Limit Line (dBuV/m)	Margin (dB)	Remark
867.8268	63.94	-7.49	56.45	80.82	-24.37	Peak
867.8268	56.45	-5.69	50.76	60.82	-10.06	Average
1301.000	68.86	-12.24	56.62	74.00	-17.38	Peak
1301.000	56.62	-5.69	50.93	54.00	-3.07	Average
1735.000	61.4	-10.60	50.80	80.82	-30.02	Peak
1735.000	50.8	-5.69	45.11	60.82	-15.71	Average
2169.000	57.02	-9.20	47.82	80.82	-33.00	Peak
2169.000	47.82	-5.69	42.13	60.82	-18.69	Average
2603.000	56.23	-7.35	48.88	80.82	-31.94	Peak
2603.000	48.88	-5.69	43.19	60.82	-17.63	Average
3037.000	66.61	-5.49	61.12	80.82	-19.70	Peak
3037.000	61.12	-5.69	55.43	60.82	-5.39	Average
3471.000	58.94	-5.08	53.86	74.00	-20.14	Peak
3471.000	53.86	-5.69	48.17	54.00	-5.83	Average

Vertical:

Freq. (MHz)	Reading Level(dBuV)	Correct Factor(dB)	Level (dBuV/m)	Limit Line (dBuV/m)	Margin (dB)	Remark
867.8268	65.59	-7.49	58.10	80.82	-22.72	Peak
867.8268	58.10	-5.69	52.41	60.82	-8.41	Average
1301.000	70.52	-12.24	58.28	74.00	-15.72	Peak
1301.000	58.28	-5.69	52.59	54.00	-1.41	Average
1735.000	61.04	-10.60	50.44	80.82	-30.38	Peak
1735.000	50.44	-5.69	44.75	60.82	-16.07	Average
2169.000	57.26	-9.20	48.06	80.82	-32.76	Peak
2169.000	48.06	-5.69	42.37	60.82	-18.45	Average
2603.000	60.19	-7.35	52.84	80.82	-27.98	Peak
2603.000	52.84	-5.69	47.15	60.82	-13.67	Average
3037.000	66.48	-5.49	60.99	80.82	-19.83	Peak
3037.000	60.99	-5.69	55.30	60.82	-5.52	Average
3471.000	64.07	-5.08	58.99	74.00	-15.01	Peak
3471.000	46.88	-5.69	41.19	54.00	-12.81	Average

Remark:

According to 15.35 (b) When average radiated emission measurements are specified in the regulations, including emission measurements below 1000 MHz, there is also a limit on the radio frequency emissions, as measured using instrumentation with a peak detector function, corresponding to 20 dB above the maximum permitted average limit for the frequency being investigated unless a different peak emission limit is otherwise specified in the rules, e.g., see Section 15.255.

5. TRANSMISSION REQUIREMENT

5.1. Requirement

1. The provisions of this Section are restricted to periodic operation within the band 40.66 40.70 MHz and above 70 MHz. Except as shown in paragraph (e) of this Section, the intentional radiator is restricted to the transmission of a control signal such as those used with alarm systems, door openers, remote switches, etc. Radio control of toys is not permitted. Continuous transmissions, such as voice or video, and data transmissions are not permitted. The prohibition against data transmissions does not preclude the use of recognition codes. Those codes are used to identify the sensor that is activated or to identify the particular component as being part of the system.
2. A manually operated transmitter shall employ a switch that will automatically deactivate the transmitter within not more than 5 seconds of being released.

5.2. Test SET-UP

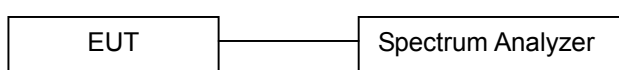

5.3. Measurement Equipment Used:

Name of Equipment	Manufacturer	Model	Serial Number	Last Cal.	CAL DUE.
Spectrum Analyzer	Rohde & Schwarz	ESCI	10017	07/18/2015	07/17/2016

5.4. Test Procedure

The following table is the setting of spectrum analyzer.

Spectrum analyzer	Setting
Attenuation	Auto
Span Frequency	0Hz
RB	1000KHz
VB	3000KHz
Detector	Peak
Trace	Max hold
Sweep Time	5S

- a. The transmitter output (antenna port) was connected to the spectrum analyzer.
- b. Set RBW of spectrum analyzer to 1000KHz and VBW to 3000KHz, Set Detector to Peak, Trace to Max Hold.
- c. Set the span to 0Hz and the sweep time to 5s and record the value.

5.5. Test Data

Environmental Conditions

Temperature:	20°C
Relative Humidity:	52%
ATM Pressure:	1032mbar

Test Mode: Transmitting

Frequency (MHz)	Transmitting time (ms)	Limit (Second)	Result
433.9134	150	5	PASS

Refer to the attached plot

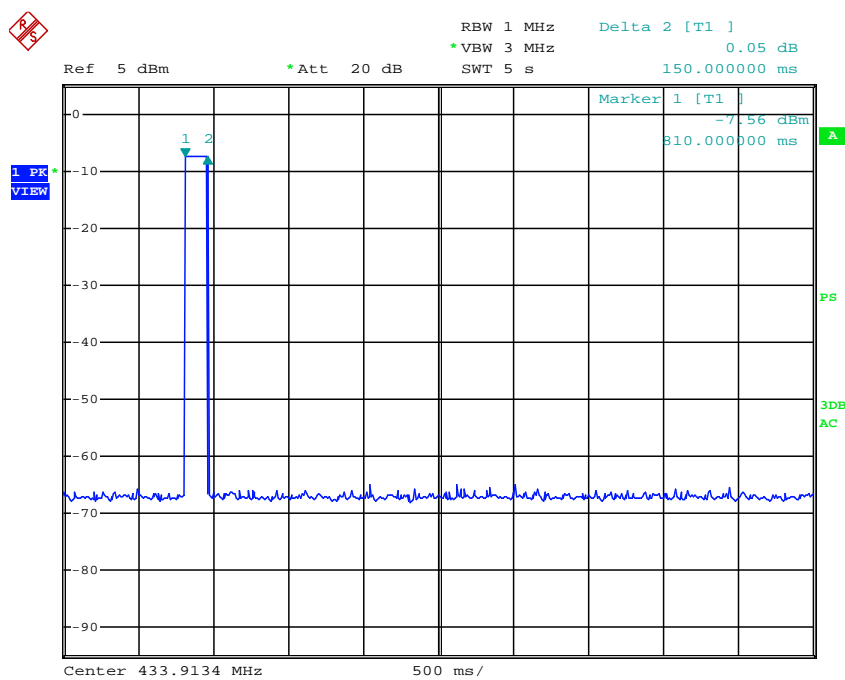

Date: 4.JAN.2016 10:07:55

6. BANDWIDTH TEST

6.1. Measurement Procedure

The useful radiated emission from the EUT was detected by the spectrum analyzer with peak detector. Record the 20 dB bandwidth of the carrier.

6.2. Test SET-UP (Block Diagram of Configuration)

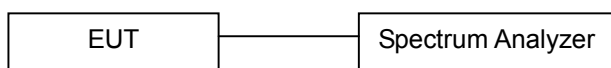

15.231 (c) The bandwidth of the emission shall be no wider than 0.25% of the center frequency for devices operating above 70 MHz and below 900 MHz. For devices operating above 900 MHz, the emission shall be no wider than 0.5% of the center frequency. Bandwidth is determined at the points 20 dB down from the modulated carrier.

6.3. Measurement Equipment Used:

Name of Equipment	Manufacturer	Model	Serial Number	Last Cal.	CAL DUE.
Spectrum Analyzer	Rohde & Schwarz	ESCI	10017	07/18/2015	07/17/2016

6.4. Measurement Results:

Spectrum Detector:	PK	Test Date:	January 04, 2016
Test By:	Jack Li	Temperature:	21°C
Test Result:	PASS	Humidity:	53 %

Channel number	Channel frequency (MHz)	20dB Down BW(kHz)	Limit
CH1	433.9134	474	≤1.08478MHz

Remark:

The bandwidth limit is $433.9134\text{MHz} \times 0.0025 = 1084.78 \text{ kHz}$.

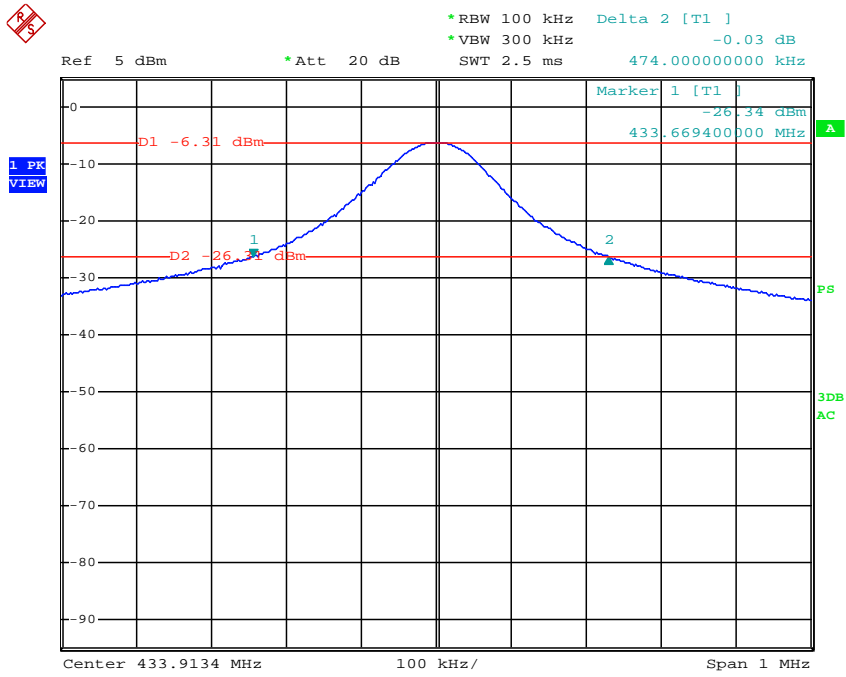

Date: 4.JAN.2016 10:06:27

7. ANTENNA APPLICATION

7.1. Antenna Requirement

For intentional device, according to FCC 47 CFR Section 15.203, an intentional radiator shall be designed to ensure that no antenna other than that furnished by the responsible party shall be used with the device.

7.2. Result

The EUT's antenna is PCB antenna, using a permanently attached antenna which is not replaceable. The antenna's gain is less than 1dBi and meets the requirement.

---END OF REPORT---