

**ELECTROMAGNETIC EMISSIONS COMPLIANCE REPORT
INTENTIONAL RADIATOR CERTIFICATION TO
FCC PART 15 SUBPART C
REQUIREMENT T**

OF

Emitter Specification

MODEL No.: DC1702;DC1762

Trademark: N/A

FCC ID: VYY-17021762

REPORT NO: ES150610132E

ISSUE DATE: July 13, 2015

Prepared for

NINGBO DOOYA MECHANIC & ELECTRONIC TECHNOLOGY CO., LTD.

Loutuo Industrial Area, Zhenhai, Ningbo, Zhejiang, China

Prepared by

SHENZHEN EMTEK CO., LTD

Bldg 69, Majialong Industry Zone, Nanshan District,
Shenzhen, Guangdong, China

TEL: 86-755-26954280

FAX: 86-755-26954282

VERIFICATION OF COMPLIANCE

| | |
|----------------------|---|
| Applicant: | NINGBO DOOYA MECHANIC & ELECTRONIC TECHNOLOGY CO., LTD. Loutuo Industrial Area, Zhenhai, Ningbo, Zhejiang, China |
| Manufacturer: | NINGBO DOOYA MECHANIC & ELECTRONIC TECHNOLOGY CO., LTD. Loutuo Industrial Area, Zhenhai, Ningbo, Zhejiang, China |
| Product Description: | Emitter Specification |
| Model Number: | DC1702;DC1762 (Note: The models of DC1702,DC1762 are identical and have same structures. We prepared model DC1702 for test) |
| Serial Number: | N/A |
| File Number: | ES150610132E |
| Date of Test: | June 22, 2015 to July 06, 2015 |

We hereby certify that:

The above equipment was tested by SHENZHEN EMTEK CO., LTD. The test data, data evaluation, test procedures, and equipment configurations shown in this report were made in accordance with the procedures given in ANSI C63.10 (2013) and the energy emitted by the sample EUT tested as described in this report is in compliance with radiated emission limits of FCC Rules Part 15.231.

The test results of this report relate only to the tested sample identified in this report.

Date of Test : June 22, 2015 to July 06, 2015

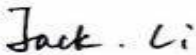
Prepared by : 
Jack Li/Editor

Reviewer : 
Joe Xia/Supervisor

Approve & Authorized Signer : 
Lisa Wang/Manager

Table of Contents

| | | |
|-----------|---|-----------|
| 1. | GENERAL INFORMATION..... | 4 |
| 1.1. | PRODUCT DESCRIPTION | 4 |
| 1.2. | RELATED SUBMITTAL(S) / GRANT (S)..... | 4 |
| 1.3. | TEST METHODOLOGY..... | 4 |
| 1.4. | SPECIAL ACCESSORIES..... | 4 |
| 1.5. | EQUIPMENT MODIFICATIONS | 4 |
| 1.6. | MEASUREMENT UNCERTAINTY | 5 |
| 1.7. | TEST FACILITY | 5 |
| 2. | SYSTEM TEST CONFIGURATION..... | 6 |
| 2.1. | EUT CONFIGURATION..... | 6 |
| 2.2. | EUT EXERCISE..... | 6 |
| 2.3. | TEST PROCEDURE..... | 6 |
| 2.4. | DESCRIPTION OF TEST MODES | 6 |
| 2.5. | SUMMARY OF TEST RESULTS | 6 |
| 2.6. | DESCRIPTION OF SUPPORT UNITS | 6 |
| 3. | RADIATED EMISSION TEST..... | 7 |
| 3.1. | MEASUREMENT PROCEDURE..... | 7 |
| 3.2. | TEST SET-UP (BLOCK DIAGRAM OF CONFIGURATION)..... | 7 |
| 3.3. | MEASUREMENT EQUIPMENT USED: | 8 |
| 3.4. | RADIATED EMISSION LIMIT..... | 8 |
| 3.5. | CALCULATION OF AVERAGE FACTOR | 10 |
| 3.6. | MEASUREMENT RESULT | 13 |
| 4. | TRANSMISSION REQUIREMENT | 15 |
| 4.1. | REQUIREMENT | 15 |
| 4.2. | TEST SET-UP | 15 |
| 4.3. | MEASUREMENT EQUIPMENT USED: | 15 |
| 4.4. | TEST PROCEDURE..... | 15 |
| 4.5. | TEST DATA..... | 15 |
| 5. | BANDWIDTH TEST..... | 17 |
| 5.1. | MEASUREMENT PROCEDURE..... | 17 |
| 5.2. | TEST SET-UP (BLOCK DIAGRAM OF CONFIGURATION)..... | 17 |
| 5.3. | MEASUREMENT EQUIPMENT USED: | 17 |
| 5.4. | MEASUREMENT RESULTS: | 17 |
| 6. | ANTENNA APPLICATION..... | 19 |
| 6.1. | ANTENNA REQUIREMENT | 19 |
| 6.2. | RESULT | 19 |

1. GENERAL INFORMATION

1.1. Product Description

Emitter Specification (referred to as the EUT in this report), it is designed by way of utilizing the ASK modulation achieves the system operating.

A major technical descriptions of EUT is described as following:

- A). Operation Frequency: 433.91MHz
- B). Modulation: ASK
- C). Antenna Type: PCB antenna
- D). Antenna Gain: <3dBi
- E).Power Supply: DC 3V from lithium battery

1.2. Related Submittal(s) / Grant (s)

This submittal(s) (test report) is intended for FCC ID: VYY-17021762 filing to comply with Section 15.231 of the FCC Part 15, Subpart C Rules.

1.3. Test Methodology

The radiated testing was performed according to the procedures in ANSI C63.10 (2013). Radiated testing was performed at an antenna to EUT distance 3 meters.

1.4. Special Accessories

Not available for this EUT intended for grant.

1.5. Equipment Modifications

Not available for this EUT intended for grant.

1.6. Measurement Uncertainty

| Measurement Type | Range | Confidence Level (%) | Calculated Uncertainty |
|-----------------------------|--------------------|----------------------|------------------------|
| Fundamental Fieldstrength | Not Applicable | 95% | ±2.94dB |
| Transmitter 20 dB Bandwidth | Not Applicable | 95% | ±0.92PPm |
| Radiated Spurious Emissions | 30 MHz to 40 GHz | 95% | ±3.00dB |
| Conducted Emission | 0.15MHz to 0.50MHz | 95% | ±2.0dB |

1.7. Test Facility

Site Description

EMC Lab.

: Accredited by CNAS, 2013.10.29
 The certificate is valid until 2016.10.28
 The Laboratory has been assessed and proved to be in compliance with CNAS/CL01:2006(identical to ISO/IEC17025: 2005)
 The Certificate Registration Number is L2291

Accredited by TUV Rheinland Shenzhen 2010.5.25
 The Laboratory has been assessed according to the requirements ISO/IEC 17025

Accredited by FCC, April 17, 2014
 The Certificate Registration Number is 406365.

Accredited by Industry Canada, March 5, 2010
 The Certificate Registration Number is 4480A-2.

Name of Firm

: SHENZHEN EMTEK CO., LTD

Site Location

: Bldg 69, Majialong Industry Zone,
 Nanshan District, Shenzhen, Guangdong, China

2. SYSTEM TEST CONFIGURATION

2.1. EUT Configuration

The EUT configuration for testing is installed on RF field strength measurement to meet the Commissions requirement and operating in a manner which intends to maximize its emission characteristics in a continuous normal application.

2.2. EUT Exercise

The Transmitter was operated in the normal operating mode. The TX frequency was fixed which was for the purpose of the measurements.

2.3. Test Procedure

2.3.1 Radiated Emissions

The EUT is placed on a turn table which is 0.8 m above ground plane. The turn table shall rotate 360 degrees to determine the position of maximum emission level. EUT is set 3m away from the receiving antenna which varied from 1m to 4m to find out the highest emission. And also, each emission was to be maximized by changing the polarization of receiving antenna both horizontal and vertical. In order to find out the max. Emission, the relative positions of this hand-held transmitter (EUT) was rotated through three orthogonal axes according to the requirements in Section 6.3 to 6.6 of ANSI C63.10-2013.

2.4. Description of test modes

The EUT (Emitter Specification) has been tested under normal operating condition. Let EUT transmit during test, and the result was reported.

2.5. Summary of Test Results

| FCC Part15, Subpart C | | |
|-----------------------|--------------------------|--------|
| Standard Section | Test Item | Result |
| FCC | | |
| 15.231(a)(1) | Transmission Requirement | Pass |
| 15.231(b) | Radiated Emission | Pass |
| 15.231(c) | 20dB Bandwidth | Pass |
| 15.207(a) | Conducted Emission | Pass |

Note: (1) "N/A" denotes test is not applicable in this test report.

2.6. Description of Support Units

| Equipment | Mfr/Brand | Model/Type No. | FCC ID / IC | Series No. | Note |
|-----------------------|-----------|----------------|--------------|------------|------|
| Emitter Specification | N/A | DC1702 | VYY-17021762 | N/A | EUT |

3. RADIATED EMISSION TEST

3.1. Measurement Procedure

- a. The EUT was placed on the top of a rotating table 0.8 meters above the ground at a 3 meter Semi-anechoic chamber. The table was rotated 360 degrees to determine the position of the highest radiation.(below 1GHz)
- b. The EUT was placed on the top of a rotating table 1.5 meters above the ground at a 3 meter Semi-anechoic chamber. The table was rotated 360 degrees to determine the position of the highest radiation.(above 1GHz)
- c. the height of the test Antenna shall vary between 1 m to 4 m. Both horizontal and vertical polarizations of the antenna are set to make the measurement.
- d. The initial step in collecting conducted emission data is a spectrum analyzer peak detector Mode pre-scanning the measurement frequency range. Significant peaks are then marked and then AV detector mode re-measured.
- e. If the Peak Mode measured value compliance with and lower than Quasi Peak Mode Limit, the EUT shall be deemed to meet QP Limits and then no additional QP Mode measurement performed.

3.2. Test SET-UP (Block Diagram of Configuration)

(A) Radiated Emission Test Set-Up, Frequency Below 30MHz

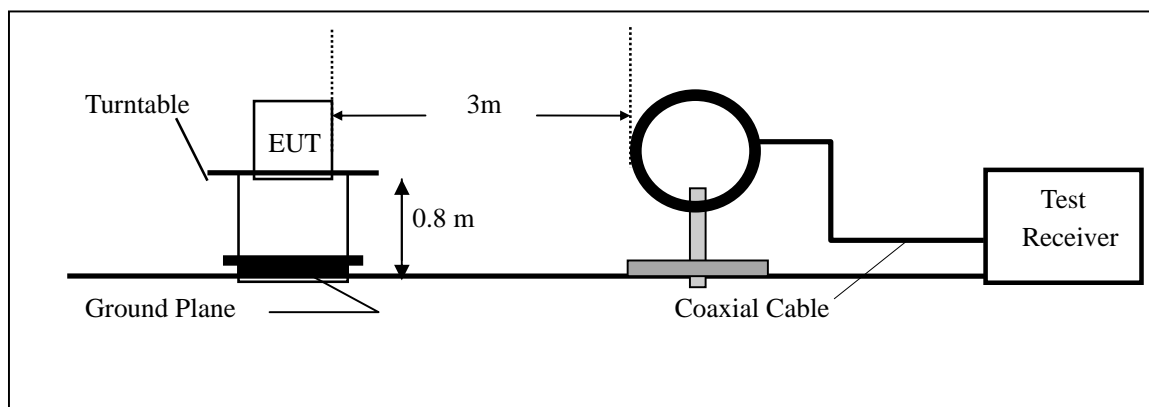

(B) Radiated Emission Test Set-Up, Frequency Below 1000MHz

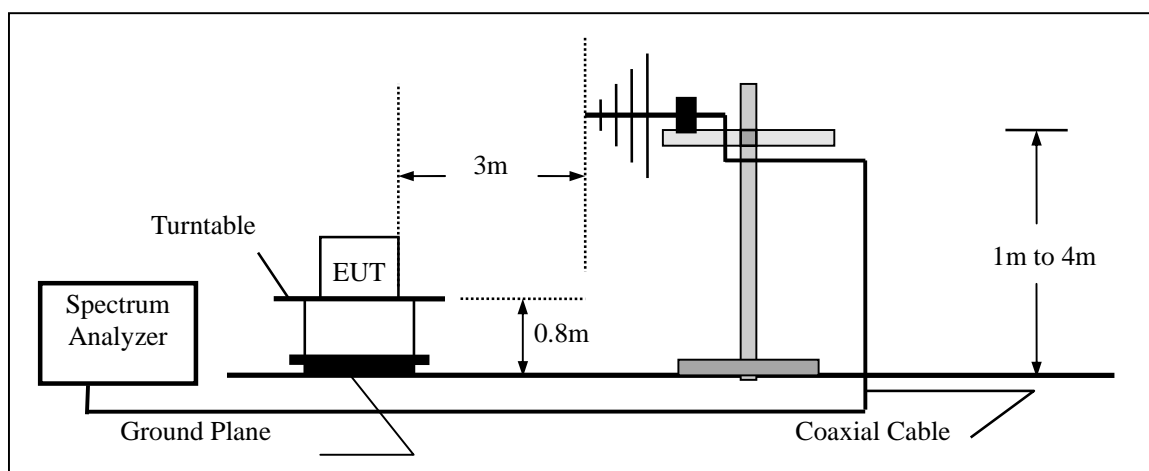

(C) Radiated Emission Test Set-Up, Frequency above 1000MHz

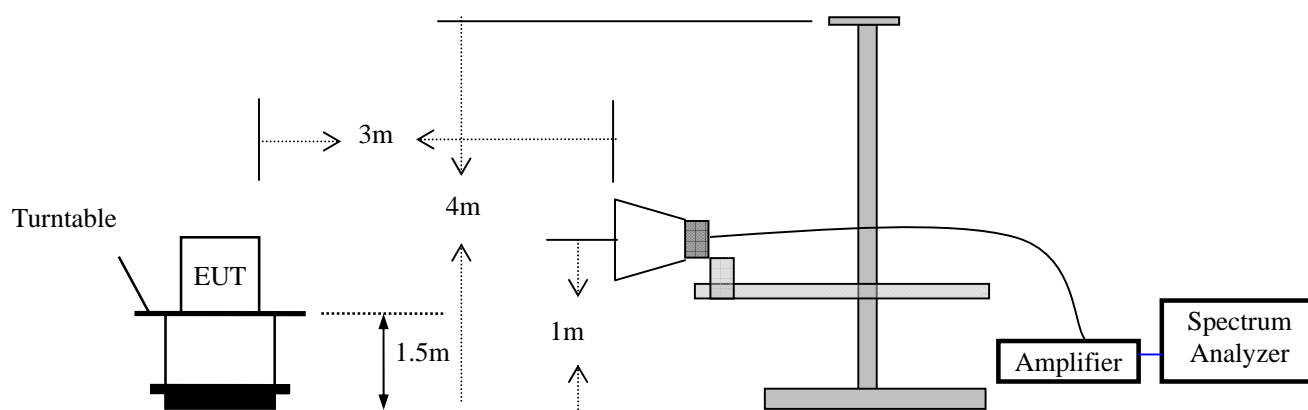

All the x/y/z orientation has been investigated, and only worst case is presented in this report.

3.3. Measurement Equipment Used:

| EQUIPMENT TYPE | MFR | MODEL NUMBER | SERIAL NUMBER | LAST CAL. | CAL DUE. |
|-------------------|-----------------|--------------|---------------|------------|------------|
| Spectrum Analyzer | Rohde & Schwarz | FSP7 | 839511/010 | 05/16/2015 | 05/15/2016 |
| Spectrum Analyzer | HP | E4407B | 839840481 | 05/16/2015 | 05/15/2016 |
| EMI Test Receiver | Rohde & Schwarz | ESCS30 | 828985/018 | 05/16/2015 | 05/15/2016 |
| Pre-Amplifier | HP | 8447D | 2944A07999 | 05/16/2015 | 05/15/2016 |
| Bilog Antenna | Schwarzbeck | VULB9163 | 142 | 05/16/2015 | 05/15/2016 |
| Loop Antenna | ARA | PLA-1030/B | 1029 | 05/16/2015 | 05/15/2016 |
| Horn Antenna | Schwarzbeck | BBHA 9170 | BBHA9170399 | 05/16/2015 | 05/15/2016 |
| Horn Antenna | Schwarzbeck | BBHA 9120 | D143 | 05/16/2015 | 05/15/2016 |

3.4. Radiated Emission Limit

FCC 15.205 Restricted frequency band

| MHz | MHz | MHz | GHz |
|----------------------------|-----------------------|-----------------|------------------|
| 0.090 - 0.110 | 16.42 - 16.423 | 399.9 - 410 | 4.5 - 5.15 |
| ¹ 0.495 - 0.505 | 16.69475 - 16.69525 | 608 - 614 | 5.35 - 5.46 |
| 2.1735 - 2.1905 | 16.80425 - 16.80475 | 960 - 1240 | 7.25 - 7.75 |
| 4.125 - 4.128 | 25.5 - 25.67 | 1300 - 1427 | 8.025 - 8.5 |
| 4.17725 - 4.17775 | 37.5 - 38.25 | 1435 - 1626.5 | 9.0 - 9.2 |
| 4.20725 - 4.20775 | 73 - 74.6 | 1645.5 - 1646.5 | 9.3 - 9.5 |
| 6.215 - 6.218 | 74.8 - 75.2 | 1660 - 1710 | 10.6 - 12.7 |
| 6.26775 - 6.26825 | 108 - 121.94 | 1718.8 - 1722.2 | 13.25 - 13.4 |
| 6.31175 - 6.31225 | 123 - 138 | 2200 - 2300 | 14.47 - 14.5 |
| 8.291 - 8.294 | 149.9 - 150.05 | 2310 - 2390 | 15.35 - 16.2 |
| 8.362 - 8.366 | 156.52475 - 156.52525 | 2483.5 - 2500 | 17.7 - 21.4 |
| 8.37625 - 8.38675 | 156.7 - 156.9 | 2690 - 2900 | 22.01 - 23.12 |
| 8.41425 - 8.41475 | 162.0125 - 167.17 | 3260 - 3267 | 23.6 - 24.0 |
| 12.29 - 12.293 | 167.72 - 173.2 | 3332 - 3339 | 31.2 - 31.8 |
| 12.51975 - 12.52025 | 240 - 285 | 3345.8 - 3358 | 36.43 - 36.5 |
| 12.57675 - 12.57725 | 322 - 335.4 | 3600 - 4400 | (²) |

FCC 15.209 Limited

| Frequencies (MHz) | Field Strength (micovolts/meter) | Measurement Distance (meters) |
|-------------------|---|-------------------------------|
| 0.009~0.490 | 2400/F(KHz) | 300 |
| 0.490~1.705 | 24000/F(KHz) | 30 |
| 1.705~30.0 | 30 | 30 |
| 30~88 | 100 | 3 |
| 88~216 | 150 | 3 |
| 216~960 | 200 | 3 |
| 960~1000 | 500 | 3 |
| Above 1GHz | 74 dBuV/m (PEAK) 54 dBuV/m (AVERAGE) | |

15.231 Limited

| Fundamental Frequency (MHz) | Field Strength of Fundamental (microvolts/meter) | Field Strength of Spurious Emissions (microvolts/meter) |
|-----------------------------|--|---|
| 40.66 - 40.70 | 2,250 | 225 |
| 70 - 130 | 1,250 | 125 |
| 130 - 174 | 1,250 to 3,750 ** | 125 to 375 ** |
| 174 - 260 | 3,750 | 375 |
| 260 - 470 | 3,750 to 12,500 ** | 375 to 1,250 ** |
| Above 470 | 12,500 | 1,250 |

** linear interpolations

The field intensity in micro-volts per meter can then be determined by the following equation: $FI(V/m) = 10FI(dBV/m) / 20$ The FCC specified emission limits were calculated according the EUT operating frequency and obtained by following linear interpolation equations:

(a) For fundamental frequency:

$$f_{EUT} : \text{EUT Operating Frequency Emission Limit (uV/m)}$$

$$= [f_{EUT}(\text{MHz}) - 260(\text{MHz})] \times \frac{12500(\text{uV/m}) - 3750(\text{uV/m})}{470(\text{MHz}) - 260(\text{MHz})} + 3750(\text{uV/m})$$

(b) For spurious frequencies:

$$f_{EUT} : \text{EUT Operating Frequency Emission Limit (V/m)}$$

$$= [f_{EUT}(\text{MHz}) - 260(\text{MHz})] \times \frac{1250(\text{uV/m}) - 375(\text{uV/m})}{470(\text{MHz}) - 260(\text{MHz})} + 375(\text{uV/m})$$

Other emissions radiated outside of the specified frequency bands, except for harmonics, shall be attenuated by at least 20 dB below the level of the fundamental or comply with the radiated emissions limits specified in section 15.209(a) limit in the table below has to be followed.

Note:

- (1) The tighter limit applies at the band edges.
- (2) Emission level (dBuV/m)=20log Emission level (uV/m).

| FCC Part15 (15.231) , Subpart C | | |
|---------------------------------|--------------------------------|--------------------------------------|
| Fundamental Frequency | Field Strength Of Fundamental | Field Strength of Spurious Emissions |
| 433.91MHz | AV:80.82 dBuV/m at 3m distance | AV:60.82 dBuV/m at 3m distance |
| | PK:100.82dBuV/m at 3m distance | PK:80.82 dBuV/m at 3m distance |

3.5. Calculation of Average factor

The output field strengths of specification in accordance with the FCC rules specify measurements with an average detector. During the test, a spectrum analyzer incorporating a peak detector was used. Therefore, a reduction factor can be applied to the resultant peak signal level and compared to the limit for measurement instrumentation incorporating an average detector.

The duty cycle is measured in 58.8ms or the repetition cycle period, whichever is a shorter time frame, the duty cycle is measured by placing the spectrum analyzer to set zero span at 100kHz resolution bandwidth.

Averaging factor in dB=20log(duty cycle)

Where the duty factor is calculated from following formula:

$$20\log(\text{Duty cycle})=20\log(26.44\text{ms}/58.8\text{ms})=-6.94 \text{ dB}$$

(Note: 26.44ms=4.84*1ms+0.36*28ms+0.72*16ms*)

Therefore, the averaging factor is -6.94dB.

Please see the diagrams below:

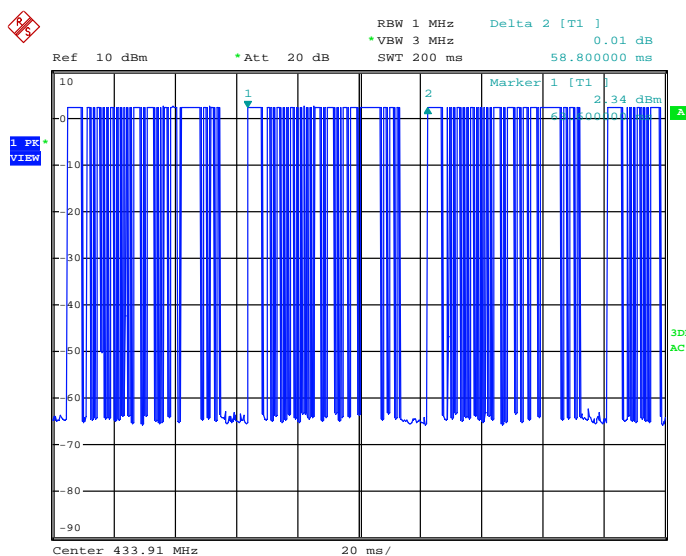

Date: 5.JUN.2015 14:29:50

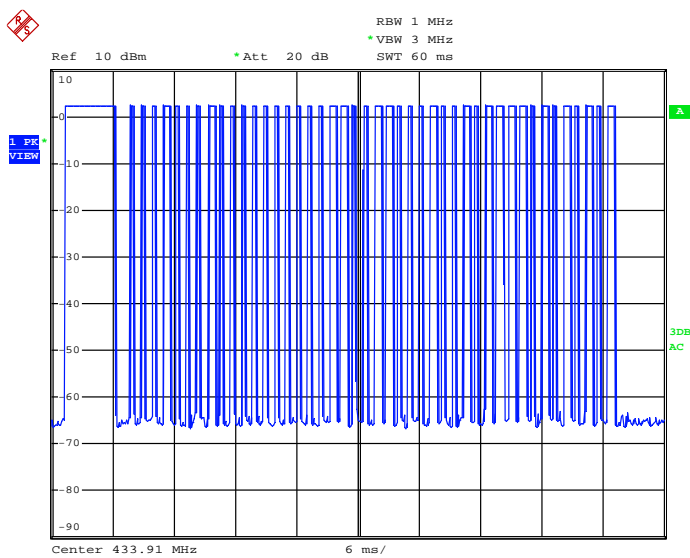

Date: 5.JUN.2015 14:36:06

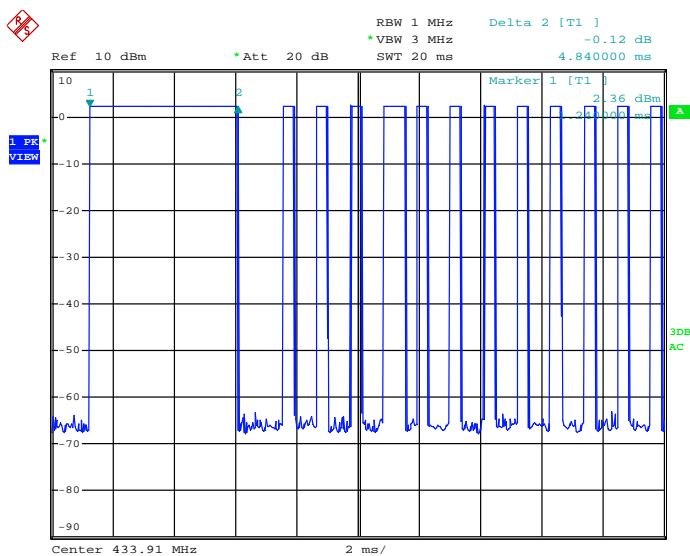

Date: 5.JUN.2015 14:36:53

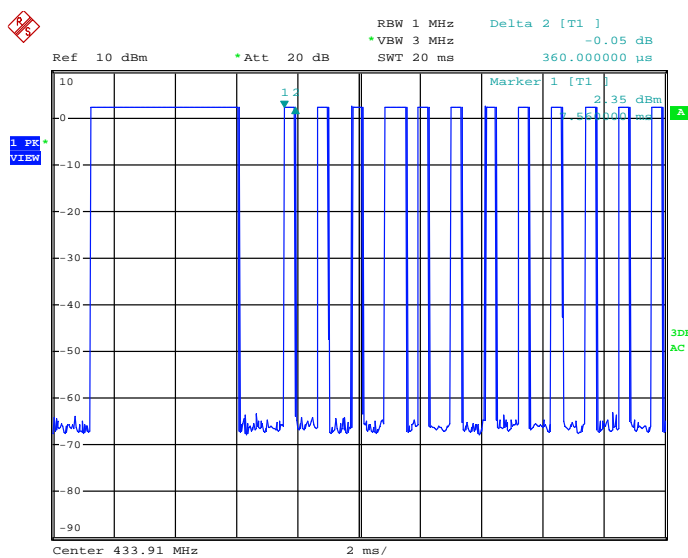

Date: 5.JUN.2015 14:37:11

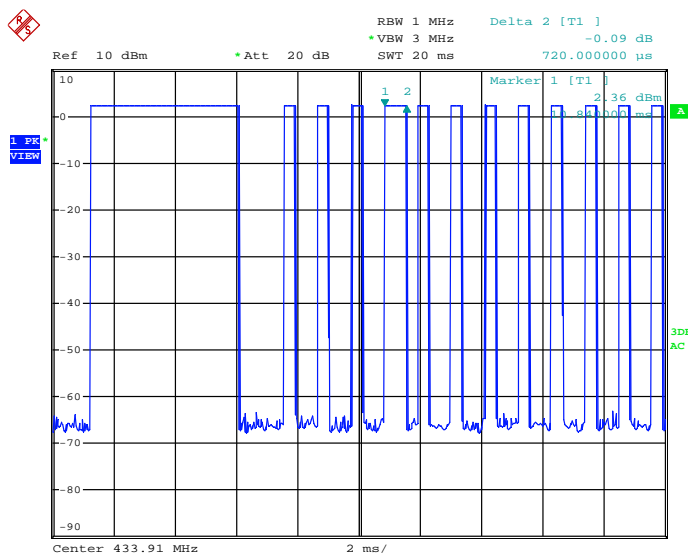

Date: 5.JUN.2015 14:37:29

3.6. Measurement Result

Below 1G

Antenna polarization:Horizontal

| Freq. (MHz) | Reading Level(dBuV) | Correct Factor(dB) | Level (dBuV/m) | Limit Line (dBuV/m) | Margin (dB) | Remark |
|-------------|---------------------|--------------------|----------------|---------------------|-------------|---------|
| 433.91 | 84.70 | -9.34 | 75.36 | 100.32 | -24.96 | Peak |
| 433.91 | 75.36 | -6.94 | 68.42 | 80.82 | -12.40 | Average |
| 867.82 | 58.69 | -2.81 | 55.88 | 80.82 | -24.95 | Peak |
| 867.82 | 55.88 | -6.94 | 48.94 | 60.82 | -11.89 | Average |

Antenna polarization:Vertical

| Freq. (MHz) | Reading Level(dBuV) | Correct Factor(dB) | Level (dBuV/m) | Limit Line (dBuV/m) | Margin (dB) | Remark |
|-------------|---------------------|--------------------|----------------|---------------------|-------------|---------|
| 433.91 | 80.55 | -9.34 | 71.21 | 100.32 | -29.11 | Peak |
| 433.91 | 71.21 | -6.94 | 64.27 | 80.82 | -16.55 | Average |
| 867.82 | 52.00 | -2.81 | 49.19 | 80.82 | -31.64 | Peak |
| 867.82 | 49.19 | -6.94 | 42.25 | 60.82 | -18.58 | Average |

Above1G

Horizontal:

| Freq. (MHz) | Reading Level(dBuV) | Correct Factor(dB) | Level (dBuV/m) | Limit Line (dBuV/m) | Margin (dB) | Remark |
|-------------|---------------------|--------------------|----------------|---------------------|-------------|---------|
| 1735.64 | 49.08 | -10.6 | 38.48 | 80.82 | -29.34 | Peak |
| 1735.64 | 38.48 | -6.94 | 31.54 | 60.82 | -17.55 | Average |
| 2603.46 | 48.37 | -7.35 | 41.02 | 80.82 | -38.31 | Peak |
| 2603.46 | 41.02 | -6.94 | 34.08 | 60.82 | -26.52 | Average |
| 3037.37 | 47.10 | -5.49 | 41.61 | 80.82 | -32.06 | Peak |
| 3037.37 | 41.61 | -6.94 | 34.67 | 60.82 | -20.27 | Average |
| 3905.19 | 48.20 | -4.46 | 43.74 | 74.00 | -36.56 | Peak |
| 3905.19 | 43.74 | -6.94 | 36.80 | 54.00 | -24.77 | Average |
| 4331.90 | 48.34 | -2.36 | 45.98 | 74.00 | -33.41 | Peak |
| 4331.90 | 45.98 | -6.94 | 39.04 | 54.00 | -21.62 | Average |
| 4449.93 | 50.99 | -1.08 | 49.91 | 80.82 | -29.59 | Peak |
| 4449.93 | 49.91 | -6.94 | 42.97 | 60.82 | -17.80 | Average |

Vertical:

| Freq. (MHz) | Reading Level(dBuV) | Correct Factor(dB) | Level (dBuV/m) | Limit Line (dBuV/m) | Margin (dB) | Remark |
|-------------|---------------------|--------------------|----------------|---------------------|-------------|---------|
| 1735.64 | 53.00 | -10.6 | 42.40 | 80.82 | -38.43 | Peak |
| 1735.64 | 42.40 | -6.94 | 35.46 | 60.82 | -25.37 | Average |
| 2603.46 | 50.20 | -7.35 | 42.85 | 80.82 | -37.98 | Peak |
| 2603.46 | 42.85 | -6.94 | 35.91 | 60.82 | -24.92 | Average |
| 3037.37 | 46.98 | -5.47 | 41.51 | 80.82 | -39.32 | Peak |
| 3037.37 | 41.51 | -6.94 | 34.57 | 60.82 | -26.26 | Average |
| 3905.19 | 48.01 | -4.5 | 43.51 | 74.00 | -30.49 | Peak |
| 3905.19 | 43.51 | -6.94 | 36.57 | 54.00 | -17.43 | Average |
| 4331.90 | 47.66 | -2.38 | 45.28 | 74.00 | -28.72 | Peak |
| 4331.90 | 45.28 | -6.94 | 38.34 | 54.00 | -15.66 | Average |
| 4479.00 | 51.01 | -1.16 | 49.85 | 80.82 | -30.98 | Peak |
| 4479.00 | 49.85 | -6.94 | 42.91 | 60.82 | -17.92 | Average |

- Note:
- (1) All Readings are Peak Value.
 - (2) Correct Factor= Antenna Factor +Cable Loss- Amplifier Gain
 - (3) Emission Level= Reading Level+Probe Factor +Cable Loss
 - (4) True Value = Emission Level + Duty Cycle Correction Factor
 - (5) DF= Duty Cycle Correction Factor
 - (6) Duty Cycle Correction Factor (dB) = 20 × Log 10 Duty Cycle
 - (7) Margin = TrueValue – limit(if margin is minus means under limit)
 - (8) The “*” means restricted bands
 - (9) All the x/y/z orientation has been investigated, and only worst case is presented in this report.

4. TRANSMISSION REQUIREMENT

4.1. Requirement

Per 15.231(a) (1), a manually operated transmitter shall employ a switch that will automatically deactivate the transmitter within not more than 5 seconds of being released.

4.2. Test SET-UP

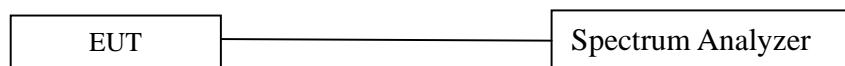

4.3. Measurement Equipment Used:

| EQUIPMENT TYPE | MFR | MODEL NUMBER | SERIAL NUMBER | LAST CAL. | CAL DUE. |
|-------------------|-----------------|--------------|---------------|------------|------------|
| EMI Test Receiver | Rohde & Schwarz | ESCS30 | 828985/018 | 05/16/2015 | 05/15/2016 |

4.4. Test Procedure

The following table is the setting of spectrum analyzer.

| Spectrum analyzer | Setting |
|-------------------|----------|
| Attenuation | Auto |
| Span Frequency | 0Hz |
| RB | 100KHz |
| VB | 300KHz |
| Detector | Peak |
| Trace | Max hold |
| Sweep Time | 6S |

- The transmitter output (antenna port) was connected to the spectrum analyzer.
- Set RBW of spectrum analyzer to 100KHz and VBW to 300KHz, Set Detector to Peak, Trace to Max Hold.
- Set the span to 0Hz and the sweep time to 6s and record the value.

4.5. Test Data

Environmental Conditions

| | |
|--------------------|----------|
| Temperature: | 24°C |
| Relative Humidity: | 53% |
| ATM Pressure: | 1032mbar |

Test Mode: Transmitting

| Frequency (MHz) | Transmitting time (ms) | Limit (Second) | Result |
|-----------------|------------------------|----------------|--------|
| 433.95 | 336 | 5 | PASS |

Refer to the attached plot

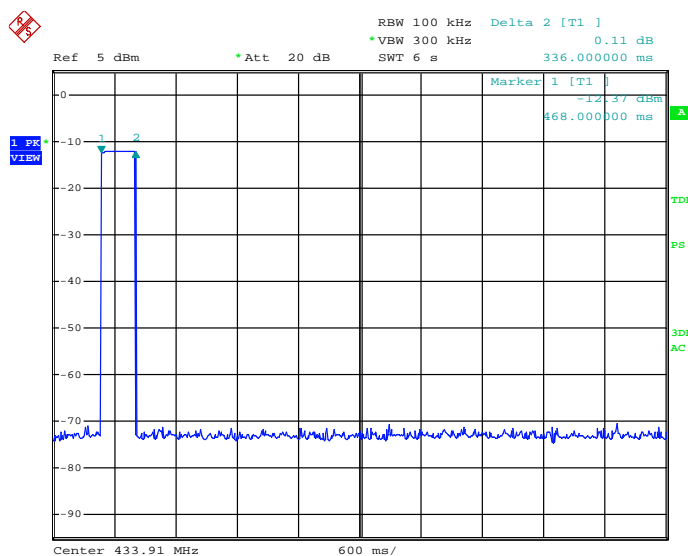

Date: 16.JUL.2015 02:18:35

Pulse Width(PW)= 0.36, $2/PW=2/0.36=5.6\text{KHz}$, $RBW=100\text{KHz}>5.6\text{KHz}$,
Therefore PDCF is not needed.

5. BANDWIDTH TEST

5.1. Measurement Procedure

The EUT was operated in hopping mode or could be controlled its channel. Print out the test result from the spectrum by hard copy function.

5.2. Test SET-UP (Block Diagram of Configuration)

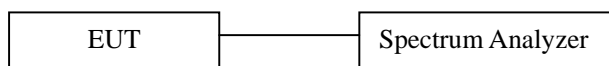

The test setup used to transmitter bandwidth measurement was the same with duty cycle test, except there is no need for digital oscilloscope in the bandwidth test. For detailed description, please reference to section 5.1, 5.2, 5.3 and 5.4 on page 11 and 12 of this report.

The resolution bandwidth of the spectrum analyzer was set to 100KHz, which is greater 5 percent of the maximum permitted bandwidth that required by the ANSI C63.10 section 6.9. Bandwidth is determined at the point 20dB down from the modulator carrier. The maximum permitted bandwidth specified by the rule was 0.25% of the center frequency of the EUT, e.g. $433.91\text{MHz} \times 0.25\% = 1.0845\text{MHz}$. The detector function was set to peak and hold mode to clearly observe the components.

5.3. Measurement Equipment Used:

| EQUIPMENT TYPE | MFR | MODEL NUMBER | SERIAL NUMBER | LAST CAL. | CAL DUE. |
|-------------------|-----------------|--------------|---------------|------------|------------|
| EMI Test Receiver | Rohde & Schwarz | ESCS30 | 828985/018 | 05/16/2015 | 05/15/2016 |

5.4. Measurement Results:

| | | | |
|--------------------|-----------|--------------|---------------|
| Spectrum Detector: | PK | Test Date: | June 23, 2014 |
| Test By: | King Kong | Temperature: | 24°C |
| Test Result: | PASS | Humidity: | 53 % |
| Modulation: | ASK | | |

| Channel number | Channel frequency (MHz) | 20dB Down BW(kHz) | Limit |
|----------------|-------------------------|-------------------|------------|
| CH1 | 433.91 | 646.0 | ≤1084.5KHz |

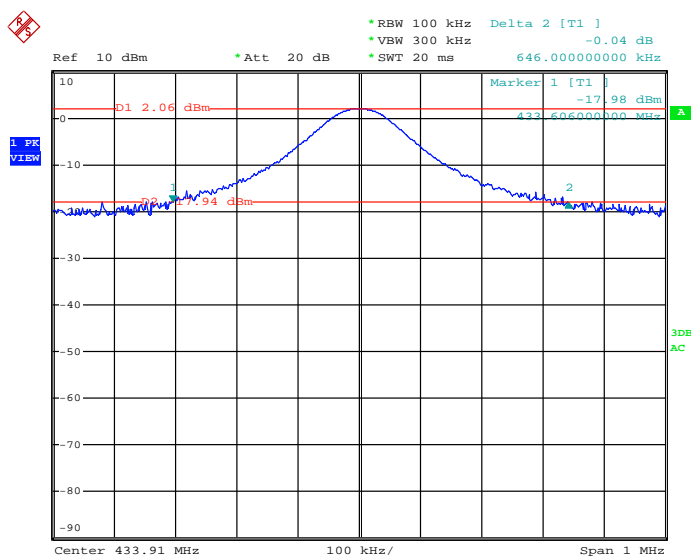

Date: 5.JUN.2015 14:19:22

6. Antenna Application

6.1. Antenna Requirement

For intentional device, according to FCC 47 CFR Section 15.203, an intentional radiator shall be designed to ensure that no antenna other than that furnished by the responsible party shall be used with the device.

6.2. Result

The EUT's antenna is PCB antenna, using a permanently attached antenna which is not replaceable. The antenna's gain is less than 3dBi and meets the requirement.

END OF REPORT