

Motion Sensor Direction Angle

JP1:NC JP2:NC	JP1:GND JP2:NC	JP1:NC JP2:GND	JP1:GND JP2:GND
0	+90	+180	-90

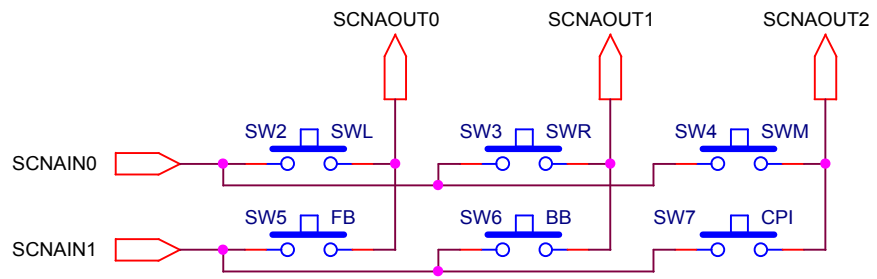

Title			<Title>
Size	Document Number	Rev	
A	<Doc>	<RevCode>	
Date:	Thursday, February 17, 2011	Sheet	1 of 1

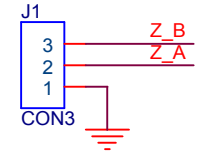
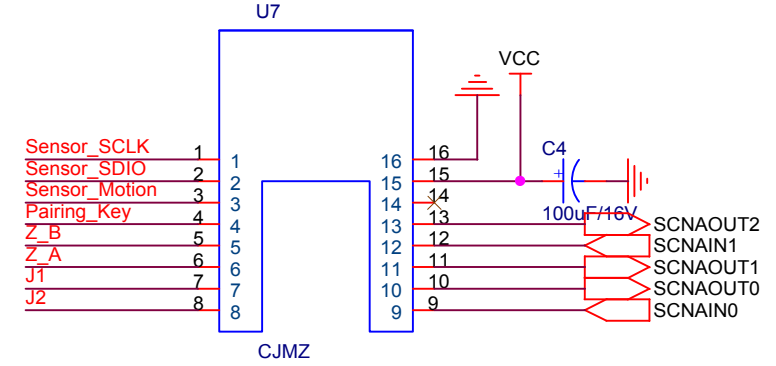
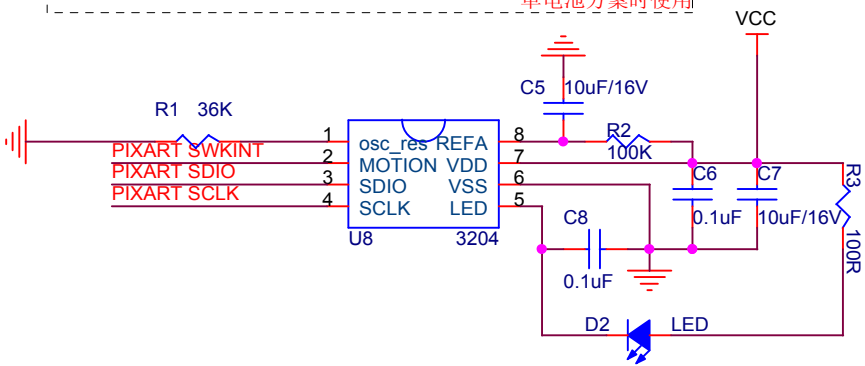
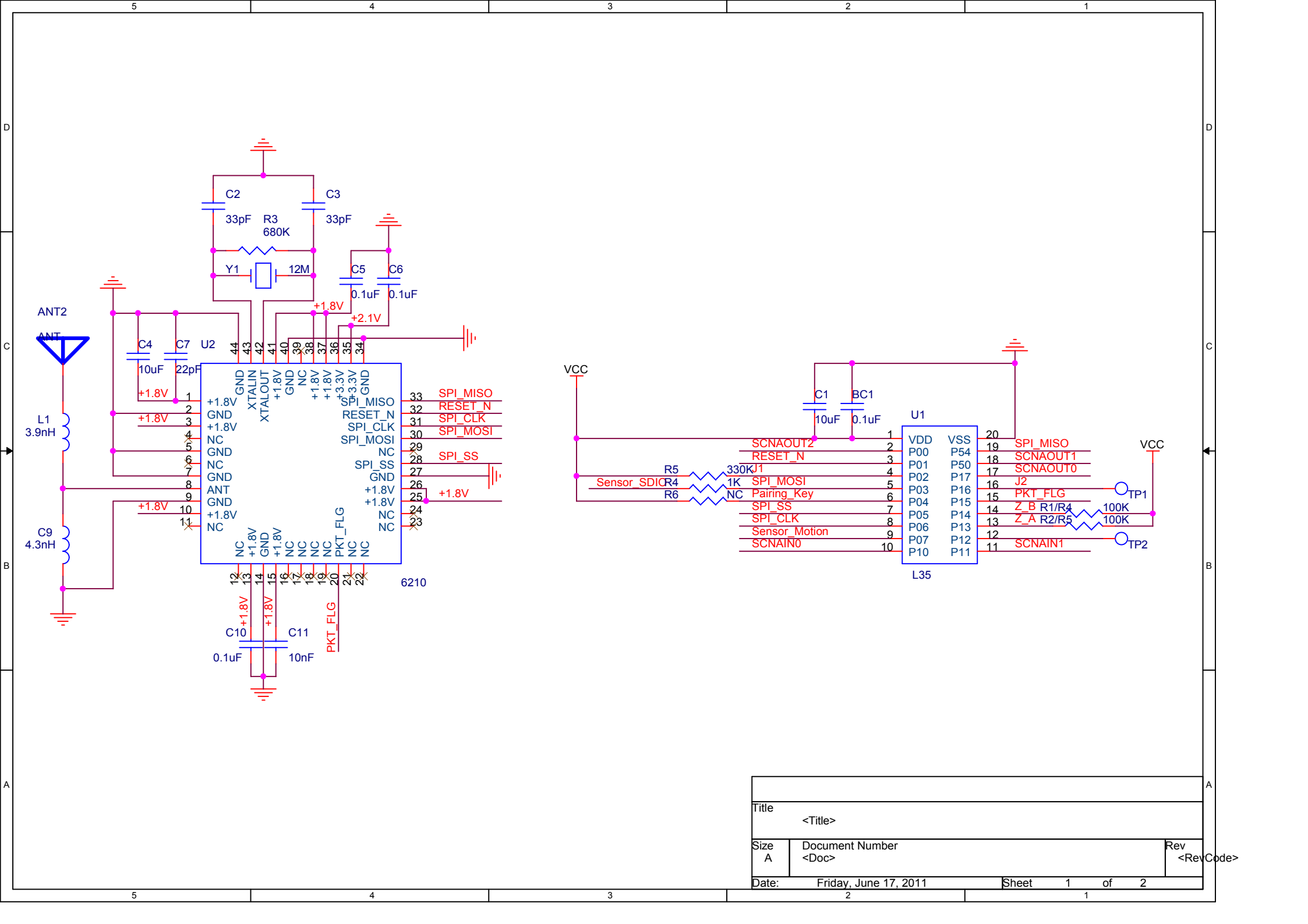

Title		
<Title>		
Size	Document Number	Rev
A	<Doc>	<RevCode>
Date:	Friday, June 17, 2011	Sheet 1 of 2