

TGW206-11

Wi-Fi 802.11b/g/n+ Bluetooth LE 5.0 Module



DISCLAIMER AND COPYRIGHT NOTICE

Information in this document, including URL references, is subject to change without notice.

This document is provided "As if" with no whatsoever, including any warranty of merchantability, noninfringement, fitness for any purpose, or any warranty otherwise arising out of any proposal, specification or samples.

All liability, including liability for infringement of any proprietary rights, relating to use of information in this document is disclaimed. No licenses express or implied, by estoppel or otherwise, to any intellectual property rights are granted herein.

The Bluetooth logo and symbol belong to the Bluetooth SIG Inc.

The Wi-Fi Alliance Member Logo is a trademark of the Wi-Fi Alliance.

All trade names, trademarks and registered trademarks mentioned in this document are property of their respective owners, and are hereby acknowledged.

Copyright ITON Technology Corp. All rights reserved.

目录Table of contents

1. Product Features.....	3
1.1 Describe.....	3
1.2 Product Features.....	3
1.3 Application scenarios.....	3
1.4 System Block Diagram.....	3
2. PIN.foot definition.....	4
2.1 Module PIN Interface Diagram.....	4
2.2 Pin function.....	4
3. Reference Application and PCB Layout.....	5
3.1 Application Schematic Reference.....	5
3.2 Refer to PCB Layout.....	5
4. Reference PCB Package.....	6
4.1 Recommended pad.....	6
4.2 Package size.....	6
5. Revise history.....	7

1. Product Features

1.1 describe

TGW206-11 is a smart new generation highly integrated Wi-Fi and Bluetooth LE combo chip. The wireless subsystem includes 2.4G radio, Wi-Fi 802.11b/g/n and BLE baseband/MAC design. The microcontroller subsystem contains a low-power 32-bit RISC CPU, cache and memory. The power management unit provides flexible settings to implement low-power modes and supports a variety of security features.

1.2 Product Features

- 802.11b/g/n, Wi-Fi+Bluetooth LE5.0 Combo, support STA, Soft AP and Sniffer
- Adopt open source self-controllable RISC-V CPU, 1~160MHz adjustable 276KB SRAM
- Ultra-low power consumption: sleep power consumption is only 0.5uA, network standby power consumption is only 40uA (DTIM10))
- Ultra-fast connection: cold start fast connection is only 70ms
- High security: support secure boot, secure debugging, AES 128/192/256 encryption engine, WPA3, MD5, SHA-1/224/256, PKA (RSA/ECC) encryption engine
- Support Wi-Fi and Bluetooth LE coexistence

1.3 Application scenarios

- [Smart Lighting](#)
- [smart switch](#)
- [smart socket](#)
- [Smart Appliances](#)
- [Monitoring remote control](#)

1.4 System Block Diagram

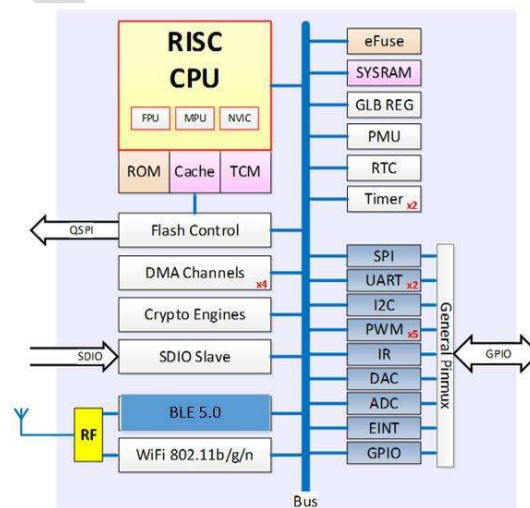

2. PIN definition

2.1 Module PIN Interface Diagram

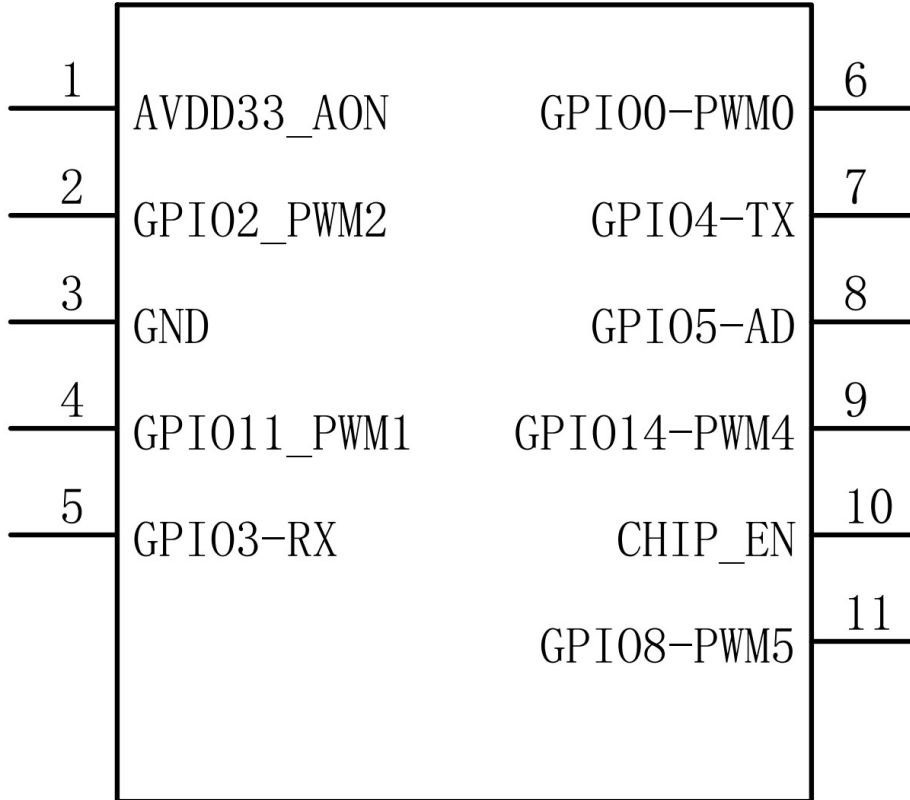

2.2 Pin Function

NO	Name	IO Type	Description
1	AVDD33	P	Power supply. 3.3V is required
2	GPIO2	I/O	GPIO2
3	GND	P	Ground connections
4	GPIO11	I/O	GPIO11
5	GPIO3	I/O	GPIO3
6	GPIO0	I/O	GPIO0
7	GPIO4	I/O	GPIO4
8	GPIO5	I/O	GPIO5
9	GPIO14	I/O	GPIO14
10	CHIP_EN	I/O	Chip enable pin (active high)
11	GPIO8	I/O	GPIO8 (Boot option).

3. Reference Application and PCB Layout

3.1 Application Schematic Reference

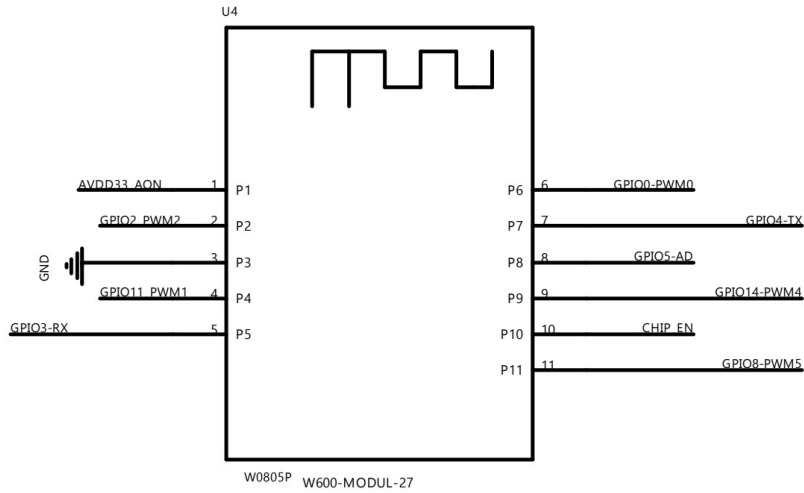

3.2 PCB Layout Reference

3.2.1 Keep the headroom at the module antenna

3.2.2 The module is far away from strong interference sources

3.2.3 The capacitor should be increased at the power supply, and the trace should be short and thick

3.2.4 The module can be attached to the PCB board, or can be soldered on the PCB board with 2.0 pin headers

3.2.5 PCB This version is an on-board antenna

4. Reference PCB Package

4.1 Recommended pad

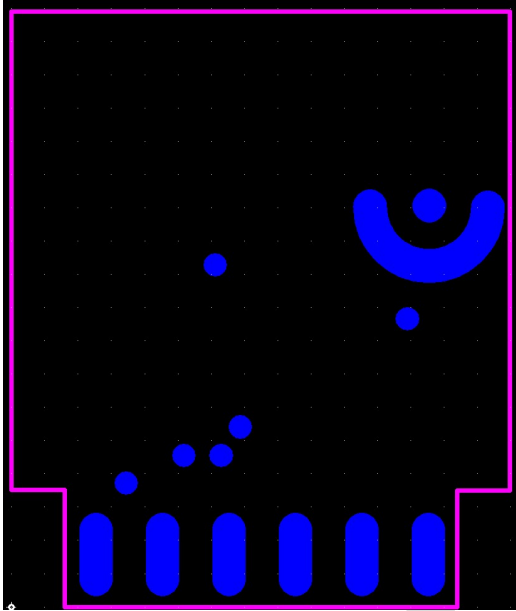

4.2 Package size

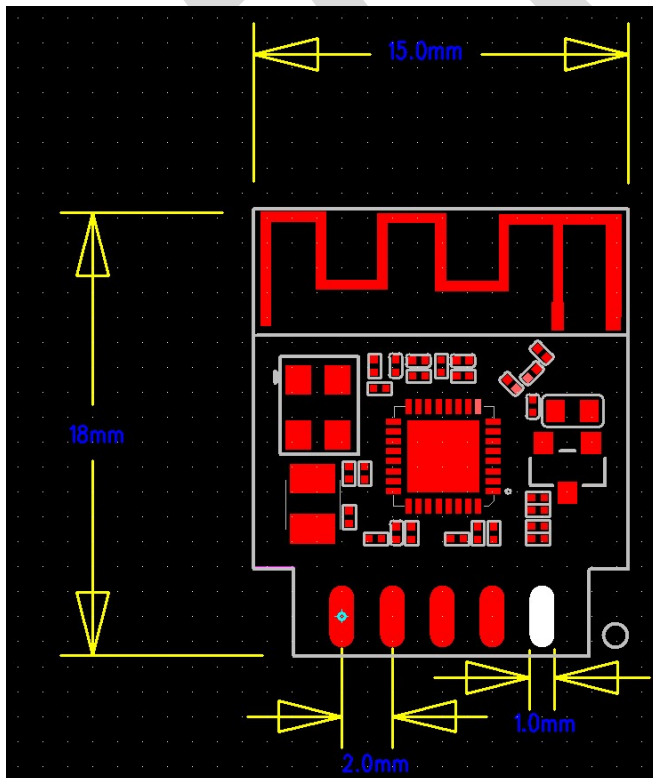

5. [Revise history](#)

Version	Modify the content	Modified by	date
V0.1	first edition	钟勇武	2021.12.10



FCC STATEMENT

This device complies with Part 15 of the FCC Rules. Operation is subject to the following two conditions:
This device may not cause harmful interference, and
This device must accept any interference received, including interference that may cause undesired operation.

Warning: Changes or modifications not expressly approved by the party responsible for compliance could void the user's authority to operate the equipment.

NOTE: This equipment has been tested and found to comply with the limits for a Class B digital device, pursuant to Part 15 of the FCC Rules. These limits are designed to provide reasonable protection against harmful interference in a residential installation. This equipment generates uses and can radiate radio frequency energy and, if not installed and used in accordance with the instructions, may cause harmful interference to radio communications. However, there is no guarantee that interference will not occur in a particular installation. If this equipment does cause harmful interference to radio or television reception, which can be determined by turning the equipment off and on, the user is encouraged to try to correct the interference by one or more of the following measures:

Reorient or relocate the receiving antenna.

Increase the separation between the equipment and receiver.

Connect the equipment into an outlet on a circuit different from that to which the receiver is connected.

Consult the dealer or an experienced radio/TV technician for help.

FCC Radiation Exposure Statement:

This equipment complies with FCC radiation exposure limits set forth for an uncontrolled environment. This equipment should be installed and operated with minimum distance 20cm between the radiator & your body.

Integration instructions for host product manufacturers according to KDB 996369 D03 OEM Manual v01

2.2 List of applicable FCC rules

FCC Part 15 Subpart C 15.247 & 15.207 & 15.209

2.3 Specific operational use conditions

Operation Frequency: BLE: 2402~2480MHz

WiFi 2.4G: 2412~2462MHz for 802.11b/g/n(HT20)

Number of Channel: BLE: 40 Channels

WiFi 2.4G: 11 Channels for 802.11b/g/n(HT20)

Modulation Type: BLE: GFSK

WiFi 2.4G: CCK, DQPSK, DBPSK for DSSS;

64QAM, 16QAM, QPSK, BPSK for OFDM

Antenna Type: BLE&WiFi 2.4G: PCB Antenna

Antenna Gain(Peak): BLE/ WiFi 2.4G: 2 dBi (Provided by customer)

The module can be used for mobile or portable applications with a maximum 2dBi antenna. The host manufacturer installing this module into their product must ensure that the final composite product complies with the FCC requirements by a technical assessment or evaluation to the FCC rules, including the transmitter operation. The host manufacturer has to be aware not to provide information to the end user regarding how to install or remove this RF module in the user's manual of the end product which integrates this module. The end user manual shall include all required regulatory information/warning as show in this manual.

2.4 Limited module procedures

Not applicable. The module is a Single module and complies with the requirement of FCC Part 15.212.

2.5 Trace antenna designs

Not applicable. The module has its own antenna, and doesn't need a host's printed board microstrip trace antenna etc.

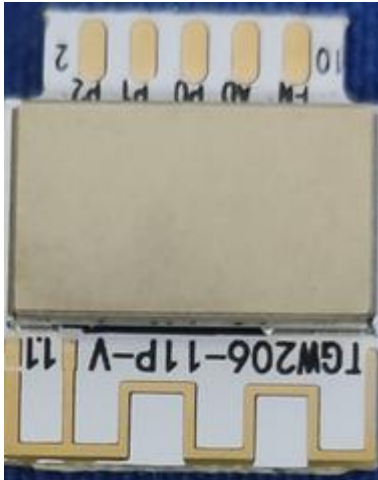

2.6 RF exposure considerations

The module must be installed in the host equipment such that at least 20cm is maintained between the antenna and users' body; and if RF exposure statement or module layout is changed, then the host product manufacturer required to take responsibility of the module through a change in FCC ID or new application. The FCC ID of the module cannot be used on the final product. In these circumstances, the host manufacturer will be responsible for re-evaluating the end product (including the transmitter) and obtaining a separate FCC authorization.

2.7 Antennas

Antenna Specification are as follows:

Antenna Type:PCB Antenna

Antenna Gain(Peak):2 dBi (Provided by customer)

This device is intended only for host manufacturers under the following conditions:

The transmitter module may not be co-located with any other transmitter or antenna;

The module shall be only used with the External antenna(s) that has been originally tested and certified with this module. The antenna must be either permanently attached or employ a 'unique' antenna coupler.

As long as the conditions above are met, further transmitter test will not be required. However, the host manufacturer is still responsible for testing their end-product for any additional compliance requirements required with this module installed (for example, digital device emissions, PC peripheral requirements, etc.).

2.8 Label and compliance information

Host product manufacturers need to provide a physical or e-label stating "Contains FCC ID **VYV-TGW206-11P** With their finished product.

2.9 Information on test modes and additional testing requirements

Operation Frequency: BLE: 2402~2480MHz

WiFi 2.4G: 2412~2462MHz for 802.11b/g/n(HT20)

Number of Channel: BLE: 40 Channels

WiFi 2.4G: 11 Channels for 802.11b/g/n(HT20)

Modulation Type: BLE: GFSK

WiFi 2.4G: CCK, DQPSK, DBPSK for DSSS;

64QAM, 16QAM, QPSK, BPSK for OFDM

Antenna Type: BLE&WiFi 2.4G: PCB Antenna

Antenna Gain(Peak): BLE/ WiFi 2.4G: 2 dBi (Provided by customer)

Host manufacturer must perform test of radiated & conducted emission and spurious emission, etc according to the actual test modes for a stand-alone modular transmitter in a host, as well as for multiple simultaneously transmitting modules or other transmitters in a host product.

Only when all the test results of test modes comply with FCC requirements, then the end product can be sold legally.

2.10 Additional testing, Part 15 Subpart B disclaimer

The modular transmitter is **only** FCC authorized for FCC Part 15 Subpart C 15.247 & 15.207 & 15.209 and that the host product manufacturer is responsible for compliance to any other FCC rules that apply to the host not covered by the modular transmitter grant of certification. If the grantee markets their product as being Part 15 Subpart B compliant (when it also contains unintentional-radiator digital circuitry), then the grantee shall provide a notice stating that the final host product still requires Part 15 Subpart B compliance testing with the modular transmitter installed.