

Note PAPE current of PA.
The Max. PAPE driving level of
RTL98192se is 10mA.

Note TR Switch PldB
specification according to
Pout that customer
specification.

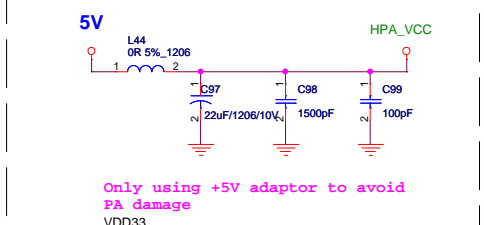

Only using +5V adaptor to avoid
PA damage

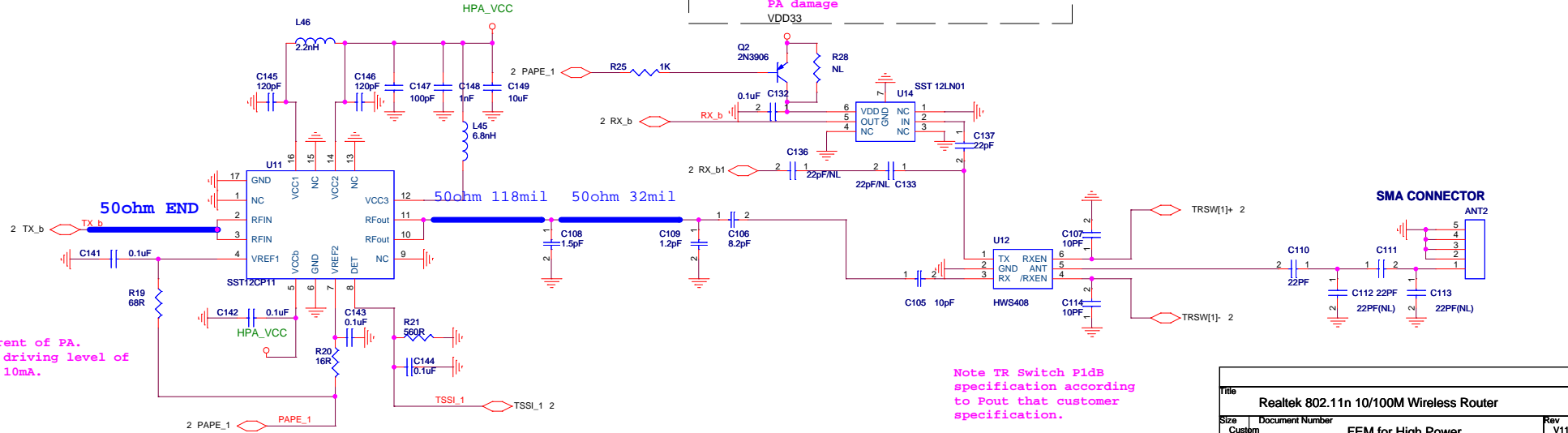

Note PAPE current of PA.
The Max. PAPE driving level of
RTL98192se is 10mA.

Note TR Switch PldB
specification according to
Pout that customer
specification.

Title			
Realtek 802.11n 10/100M Wireless Router			
Size	Document Number	Rev	
Custom	FEM for High Power	V110	
Date:	Wednesday, September 30, 2009	Sheet	1 of 2

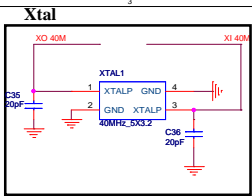
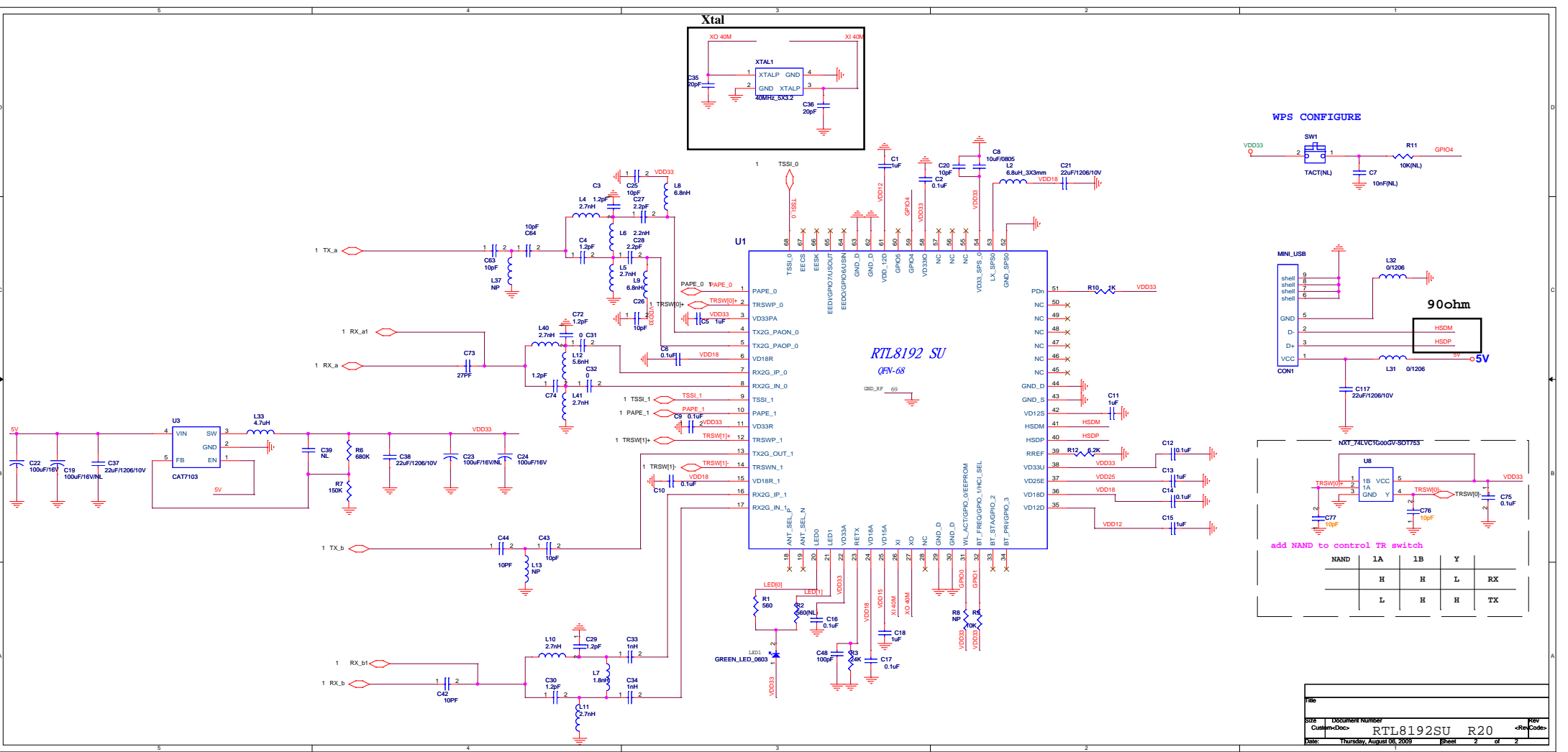

WPS CONFIGURE

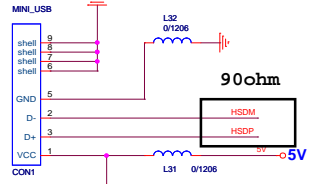
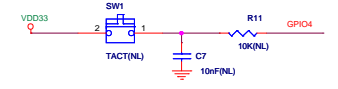

90ohm

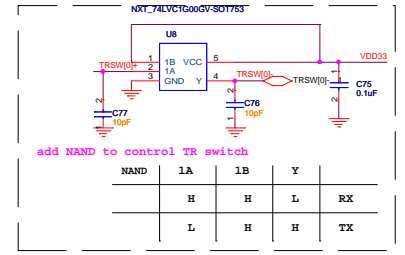

add NAND to control TR switch

NAND	1A	1B	Y	
	H	H	L	RX
	L	H	H	TX