



FCC TEST REPORT

According to

FCC Rules and Regulations Part 15 Subpart C

Applicant : Loopcomm Technology Inc.
Address : 6F., No.236, Bo'ai St., Shulin Dist., New Taipei
City 238, Taiwan (R.O.C.)
Equipment : 802.11 B/G/N Wireless PCI –E Card (2T2R)
Model No. : LP-7694(100mW)
Trade Name : Loopcomm

- The test result refers exclusively to the test presented test model / sample.,
- Without written approval of **CerpPASS Technology Corp.**, the test report shall not be reproduced except in full.
- The EUT is also considered as a kind of computer peripheral, because the connection to computer is necessary for typical use. It has been verified to comply with the requirements of FCC Part 15, Subpart B, Class B (DoC). The test report has been issued separately.



Contents

1. Report of Measurements and Examinations	6
1.1 List of Measurements and Examinations	6
2. Test Configuration of Equipment under Test	7
2.1 Feature of Equipment under Test	7
2.2 Carrier Frequency of Channels	7
2.3 Test Mode and Test Software	8
2.4 Description of Test System	8
2.5 General Information of Test	9
2.6 Measurement Uncertainty	9
3. Antenna Requirements	10
3.1 Standard Applicable	10
3.2 Antenna Construction and Directional Gain	10
4. Test of Conducted Emission	11
4.1 Test Limit	11
4.2 Test Procedures	11
4.3 Typical Test Setup	12
4.4 Measurement Equipment	12
4.5 Test Result and Data	13
4.6 Test Photographs	19
5. Test of Radiated Emission	20
5.1 Test Limit	20
5.2 Test Procedures	20
5.3 Typical Test Setup	21
5.4 Measurement Equipment	21
5.5 Test Result and Data (9kHz ~ 30MHz)	22
5.6 Test Result and Data	22
5.7 Test Photographs (30MHz~1000MHz)	58
5.8 Test Photographs (1000MHz~25000MHz)	59
6. 6dB Bandwidth Measurement Data	60
6.1 Test Limit	60
6.2 Test Procedures	60
6.3 Test Setup Layout	60
6.4 Measurement Equipment	60
6.5 Test Result and Data	60
7. Maximum Peak and Average Output Power	73
7.1 Test Limit	73
7.2 Test Procedures	73
7.3 Test Setup Layout	73
7.4 Measurement Equipment	73
7.5 Test Result and Data	74
8. Power Spectral Density	100
8.1 Test Limit	100
8.2 Test Procedures	100
8.3 Test Setup Layout	100



8.4 Measurement Equipment..... 100

8.5 Test Result and Data..... 100

9. Band Edges Measurement..... 114

9.1 Test Limit..... 114

9.2 Test Procedure..... 114

9.3 Test Setup Layout..... 114

9.4 Measurement Equipment..... 114

9.5 Test Result and Data..... 115

9.6 Restrict Band Emission Measurement Data..... 132

10. Restricted Bands of Operation..... 134

10.1 Labeling Requirement..... 134

Appendix A. Photographs of EUT.....A1 ~ A3



History of this test report

■ ORIGINAL.

Additional attachment as following record:

Attachment No.	Issue Date	Description
TEF1206193	Aug. 17, 2012	Original.



CERTIFICATE OF COMPLIANCE

According to

FCC Rules and Regulations

Part 15 Subpart C

Applicant : Loopcomm Technology Inc.
Address : 6F., No.236, Bo'ai St., Shulin Dist.,
New Taipei City 238, Taiwan (R.O.C.)
Equipment : 802.11 B/G/N Wireless PCI –E Card (2T2R)
Model No. : LP-7694(100mW)

I HEREBY CERTIFY THAT :

The measurements shown in this test report were made in accordance with the procedures given in **ANSI C63.4 2009, KDB558074 & KDB662911**. The equipment was **passed** the test performed according to **FCC Rules and Regulations Part 15 Subpart C (2010)**. The test was carried out on Aug. 09, 2012 at CerpPASS Technology Corp.

Approved by:

Tested by:

Hill Chen
EMC/RF B.U. Assistant Manager

Ben Lu
Engineer



1. Report of Measurements and Examinations

1.1 List of Measurements and Examinations

FCC Rule	Description of Test	Result
15.203	. Antenna Requirement	Pass
15.207	. Conducted Emission	Pass
15.209 15.247(d)	. Radiated Emission	Pass
15.247(a)(2)	. 6dB Bandwidth	Pass
15.247(b)	. Maximum Peak Output Power	Pass
15.247(d)	. 100kHz Bandwidth of Frequency Band Edges	Pass
15.247(e)	. Power Spectral Density	Pass
1.1307 1.1310 2.1091 2.1093	. RF Exposure Compliance	Pass



2. Test Configuration of Equipment under Test

2.1 Feature of Equipment under Test

- Complies with 2.4GHz IEEE802.11 b/g/n standards
- Two detachable 2 dBi antenna.
- Wireless security- 64/128bit WEP, WPA ,WPA2
- High quality Ralink wireless b/g/n solution
- 2T2R with 300Mbps PHY rate for both transmit and receiving.
- Legacy and High throughput modes
- 20MHz/40MHz Bandwidth
- Qos-WMM, WMM-PS
- Multiple BSSID Support
- Support Soft AP

2.2 Carrier Frequency of Channels

802.11b, 802.11g, 802.11n HT 20

Channel	Frequency(MHz)	Channel	Frequency(MHz)
01	2412	07	2442
02	2417	08	2447
03	2422	09	2452
04	2427	10	2457
05	2432	11	2462
06	2437	---	---

802.11n, HT40

Channel	Frequency(MHz)	Channel	Frequency(MHz)
---	---	08	2447
---	---	09	2452
03	2422	---	---
04	2427	---	---
05	2432	---	---
06	2437	---	---
07	2442	---	---



2.3 Test Mode and Test Software

- a. During testing, the interface cables and equipment positions were varied according to ANSI C63.4.
- b. The complete test system included PC, Monitor, Mouse, Keyboard and EUT for RF test.
- c. An executive program, "QA TEST" under WIN Vista was executed to transmit and receive data to the remote workstation through WLAN.
- d. The following test modes were performed for test:
 - 802.11b/g/n HT20: CH01: 2412MHz, CH06: 2437MHz, CH11: 2462MHz
 - 802.11n HT40: CH03: 2422MHz, CH06: 2437MHz, CH09: 2452MHz

* Power output of data rate:

802.11b		802.11g		802.11n HT20		802.11n HT40	
Data Rate (Mbps)	Power output (dBm)	Data Rate (Mbps)	Power output (dBm)	Data Rate (Mbps)	Power output (dBm)	Data Rate (Mbps)	Power output (dBm)
11	15.71	54	11.90	130/15	11.03	270/15	10.72
5.5	15.66	48	11.85	117/14	10.97	243/14	10.68
2	15.65	36	11.86	104/13	10.96	216/13	10.66
1	15.69	24	11.84	78/12	10.93	162/12	10.63
---	---	18	11.85	52/11	10.95	108/11	10.63
---	---	12	11.81	39/10	10.89	81/10	10.59
---	---	9	11.86	26/9	10.87	54/9	10.59
---	---	6	11.87	13/8	10.86	27/8	10.55
---	---	---	---	65/7	10.85	135/7	10.56
---	---	---	---	58.5/6	10.87	121.5/6	10.59
---	---	---	---	52/5	10.90	108/5	10.62
---	---	---	---	39/4	10.93	81/4	10.65
---	---	---	---	26/3	10.93	54/3	10.66
---	---	---	---	19.5/2	10.95	40.5/2	10.68
---	---	---	---	13/1	10.95	27/1	10.67
---	---	---	---	6.5/0	11.00	13.5/0	10.69

2.4 Description of Test System

Device	Manufacturer	Model No.	Description
PC	DELL	D02M	Power Cable, Unshielding 1.8m
Monitor	DELL	U2410f	Data Cable, VGA Shielding, 1.35m
Mouse	DELL	M-UV83	Data Cable, USB Shielding, 1.85m
Keyboard	DELL	SK-8175	Data Cable, USB Shielding, 1.85m



2.5 General Information of Test

Test Site :	CerpPASS Technology Corp. 2F-11, No. 3, Yuan Qu St., (Nankang Software Park), Taipei, Taiwan 115, R.O.C.
Test Site Location (OATS2-SD) :	No.68-1, Shihbachongsi, Shihding Township, Taipei City 223, Taiwan, R.O.C.
FCC Registration Number :	TW1049, TW1061, 390316, 488071
IC Registration Number :	4934B-1, 4934D-1
VCCI Registration Number :	T-1173 for Telecommunication Test C-4139 for Conducted emission test R-3428 for Radiated emission test G-97 for Radiated emission test above 1GHz
Frequency Range Investigated:	Conducted: from 150kHz to 30MHz Radiation: from 30MHz to 25,000MHz
Test Distance:	The test distance of radiated emission from antenna to EUT is 3 M.
Laboratory Accreditation	

2.6 Measurement Uncertainty

Measurement Item	Uncertainty
Radiated emission	± 4.11 dB
Peak Output Power(conducted)	± 1.38 dB
Peak Output Power(Radiated)	± 1.70 dB
Power Spectral Density	± 1.39 dB
Radiated emission(3m)	± 4.11 dB
Radiated emission(10m)	± 3.89 dB



3. Antenna Requirements

3.1 Standard Applicable

For intentional device, according to FCC 47 CFR Section 15.203, an intentional radiator shall be designed to ensure that no antenna other than that furnished by the responsible party shall be used with the device.

And according to FCC 47 CFR Section 15.247 (b), if transmitting antennas of directional gain greater than 6dBi are used, the power shall be reduced by the amount in dB that the directional gain of the antenna exceeds 6dBi.

3.2 Antenna Construction and Directional Gain

ANT R

Antenna Type: Dipole Antenna

Antenna Gain: 2 dBi

ANT L

Antenna Type: Dipole Antenna

Antenna Gain: 2 dBi

Note: Directional gain = $G_{ANT} + 10 \log(N)$ dBi = $2 + 10 \log(2) = 5.01$ (dBi)



4. Test of Conducted Emission

4.1 Test Limit

Conducted Emissions were measured from 150 kHz to 30 MHz with a bandwidth of 9 KHz on the 120 VAC power and return leads of the EUT according to the methods defined in ANSI C63.4-2009 Section 3.1. The EUT was placed on a nonmetallic stand in a shielded room 0.8 meters above the ground plane as shown in section 2.2. The interface cables and equipment positioning were varied within limits of reasonable applications to determine the position produced maximum conducted emissions.

Frequency (MHz)	Quasi Peak (dB μ V)	Average (dB μ V)
0.15 – 0.5	66-56*	56-46*
0.5 – 5.0	56	46
5.0 – 30.0	60	50

*Decreases with the logarithm of the frequency.

4.2 Test Procedures

- a. The EUT was placed 0.4 meter from the conducting wall of the shielding room was kept at least 80 centimeters from any other grounded conducting surface.
- b. Connect EUT to the power mains through a line impedance stabilization network (LISN).
- c. All the support units are connecting to the other LISN.
- d. The LISN provides 50 ohm coupling impedance for the measuring instrument.
- e. The FCC states that a 50 ohm, 50 micro-Henry LISN should be used.
- f. Both sides of AC line were checked for maximum conducted interference.
- g. The frequency range from 150 kHz to 30 MHz was searched.
- h. Set the test-receiver system to Peak Detect Function and Specified Bandwidth with Maximum Hold Mode.



4.3 Typical Test Setup

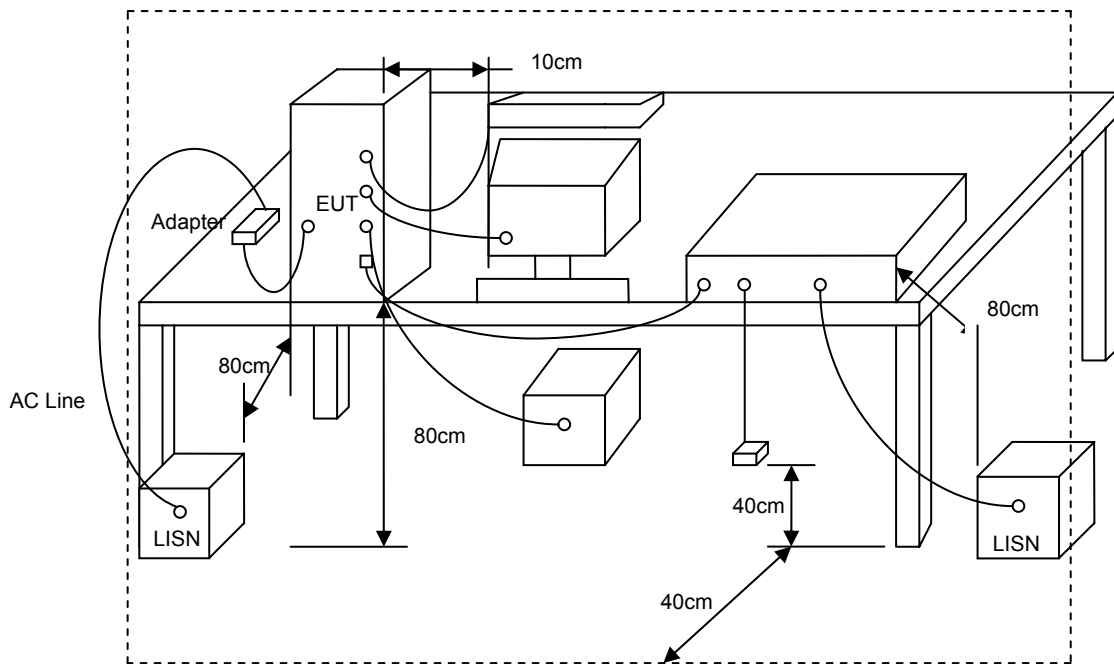

4.4 Measurement Equipment

Instrument/Ancillary	Model No.	Manufacturer	Serial No.	Calibration Date	Valid Date
EMI Receiver	R&S	ESCI	100443	2012/01/12	2013/01/11
LISN	Schwarzbeck	NSLK 8127	8127-516	2012/03/08	2013/03/07
LISN	Schwarzbeck	NSLK 8127	8127-568	2011/08/24	2012/08/23



4.5 Test Result and Data

Power	: From System	Pol/Phase	: LINE
Test Mode 1	: 802.11g, CH1	Temperature	: 25 °C
Test Date	: Aug. 09, 2012	Humidity	: 65 %

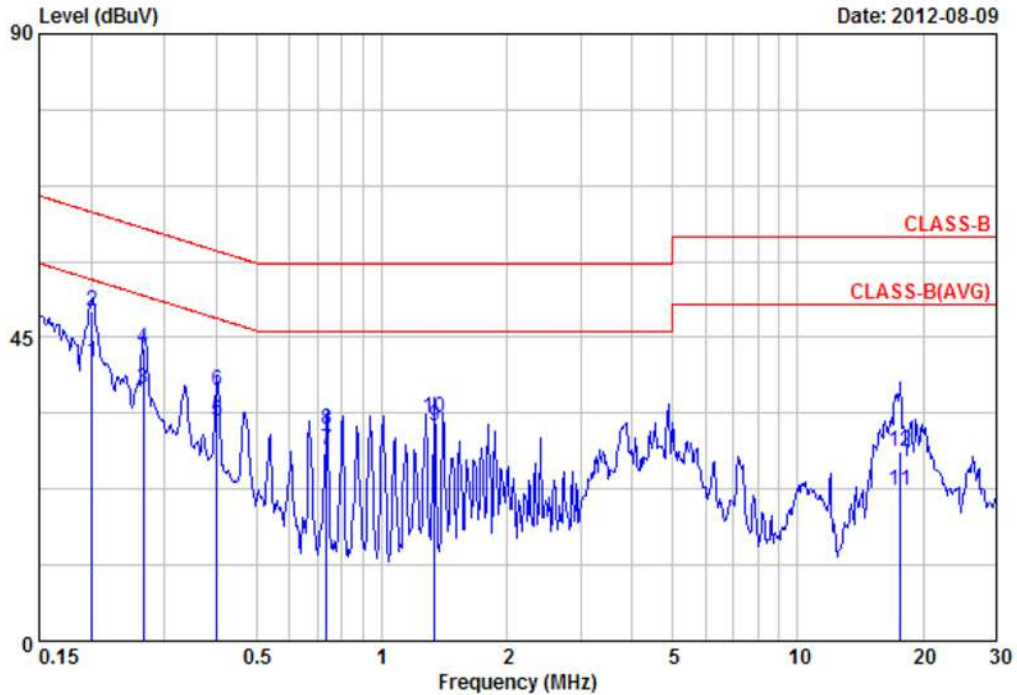

Item	Freq	Read Value	Factor	Result	Limit	Margin	Remark
	MHz	dBuV	dB/m	dBuV/m	dBuV/m	dB	
1	0.20	41.22	0.12	41.34	53.58	-12.24	Average
2	0.20	48.69	0.12	48.81	63.58	-14.77	QP
3	0.27	37.15	0.12	37.27	51.20	-13.93	Average
4	0.27	43.30	0.12	43.42	61.20	-17.78	QP
5	0.40	32.56	0.13	32.69	47.81	-15.12	Average
6	0.40	37.07	0.13	37.20	57.81	-20.61	QP
7	0.74	28.11	0.17	28.28	46.00	-17.72	Average
8	0.74	31.21	0.17	31.38	56.00	-24.62	QP
9	1.34	31.74	0.22	31.96	46.00	-14.04	Average
10	1.34	32.87	0.22	33.09	56.00	-22.91	QP
11	17.66	21.51	0.90	22.41	50.00	-27.59	Average
12	17.66	27.15	0.90	28.05	60.00	-31.95	QP

Notes:

1. Result = Read Value + Factor
2. Factor = LISN Factor + Cable Loss
3. All emission below 1GHz at 802.11g/n mode are all the same, so the 802.11g/n mode chosen as representative in final test.
4. According to technical experiences, all spurious emission of 802.11g/n mode at channel 1, 6, 11 or 3, 6, 9 (for HT40) are almost the same below 1GHz, so that the channel 1 or 3 (for HT40) was chosen as representative in final test.
5. The data is worse case.



Power	: From System	Pol/Phase	: NEUTRAL
Test Mode 1	: 802.11g, CH1	Temperature	: 25 °C
Test Date	: Aug. 09, 2012	Humidity	: 65 %

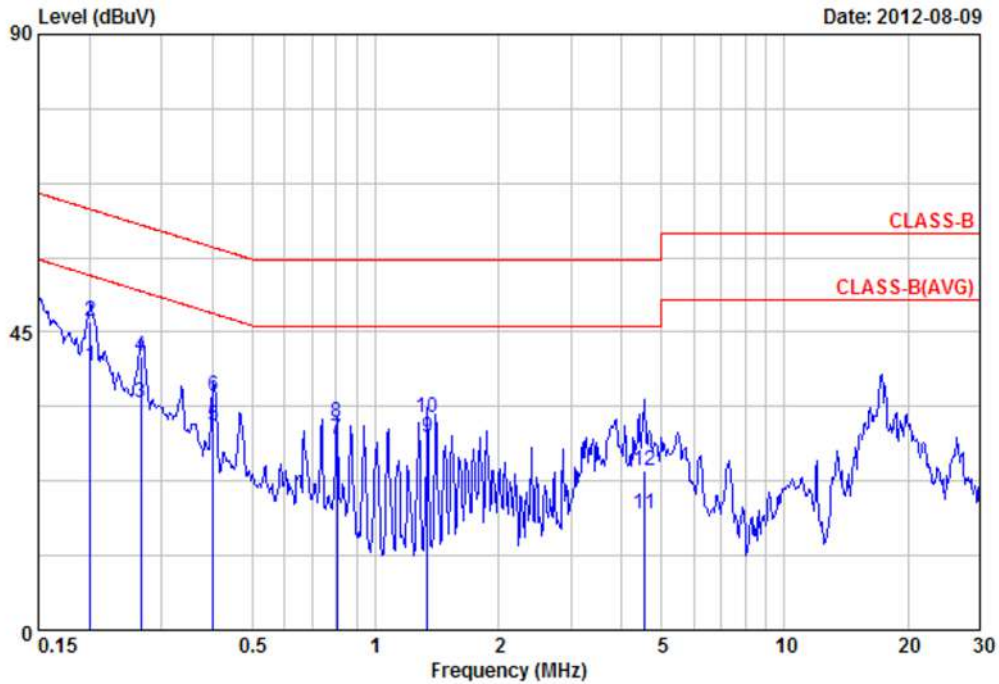

Item	Freq	Read Value	Factor	Result	Limit	Margin	Remark
	MHz	dBuV	dB/m	dBuV/m	dBuV/m	dB	
1	0.20	39.74	0.10	39.84	53.58	-13.74	Average
2	0.20	46.48	0.10	46.58	63.58	-17.00	QP
3	0.27	34.20	0.10	34.30	51.20	-16.90	Average
4	0.27	41.36	0.10	41.46	61.20	-19.74	QP
5	0.40	30.70	0.12	30.82	47.81	-16.99	Average
6	0.40	35.29	0.12	35.41	57.81	-22.40	QP
7	0.80	28.68	0.16	28.84	46.00	-17.16	Average
8	0.80	31.14	0.16	31.30	56.00	-24.70	QP
9	1.34	28.91	0.20	29.11	46.00	-16.89	Average
10	1.34	31.86	0.20	32.06	56.00	-23.94	QP
11	4.53	17.32	0.34	17.66	46.00	-28.34	Average
12	4.53	23.74	0.34	24.08	56.00	-31.92	QP

Notes:

1. Result = Read Value + Factor
2. Factor = LISN Factor + Cable Loss
3. All emission below 1GHz at 802.11b/g/n mode are all the same, so the 802.11g/n mode chosen as representative in final test.
4. According to technical experiences, all spurious emission of 802.11g/n mode at channel 1, 6, 11 or 3, 6, 9 (for HT40) are almost the same below 1GHz, so that the channel 1 or 3 (for HT40) was chosen as representative in final test.
5. The data is worse case.



Power	: From System	Pol/Phase	: LINE
Test Mode 2	: 802.11n HT20, CH1	Temperature	: 25 °C
Test Date	: Aug. 09, 2012	Humidity	: 65 %

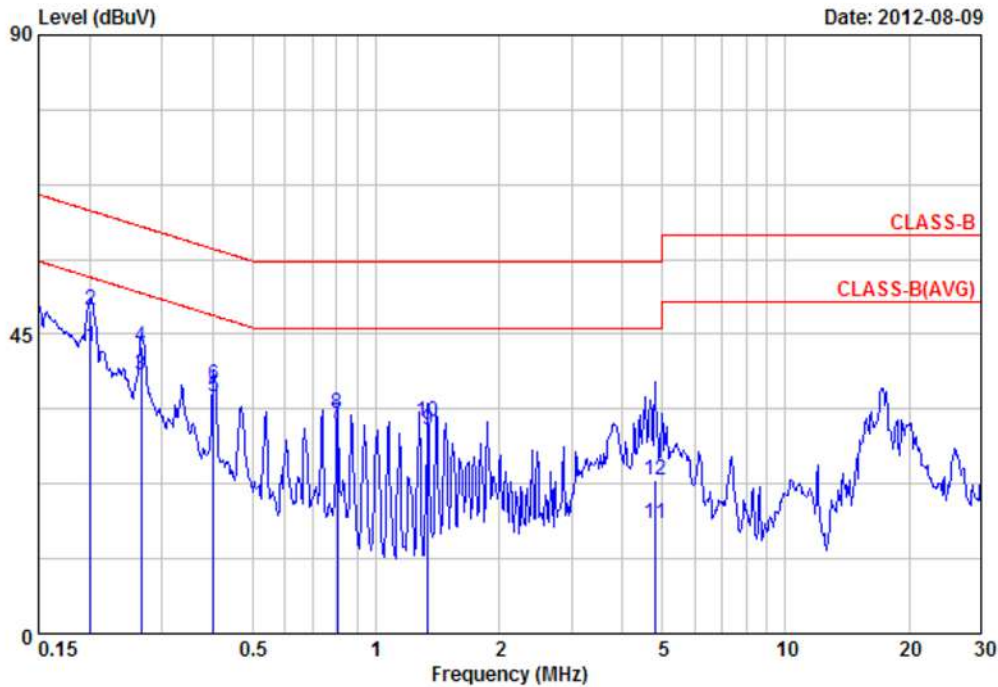

Item	Freq	Read Value	Factor	Result	Limit	Margin	Remark
	MHz	dBuV	dB/m	dBuV/m	dBuV/m	dB	
1	0.20	42.97	0.12	43.09	53.58	-10.49	Average
2	0.20	48.43	0.12	48.55	63.58	-15.03	QP
3	0.27	38.86	0.12	38.98	51.20	-12.22	Average
4	0.27	43.12	0.12	43.24	61.20	-17.96	QP
5	0.40	35.58	0.13	35.71	47.81	-12.10	Average
6	0.40	37.25	0.13	37.38	57.81	-20.43	QP
7	0.80	31.42	0.18	31.60	46.00	-14.40	Average
8	0.80	32.96	0.18	33.14	56.00	-22.86	QP
9	1.34	30.46	0.22	30.68	46.00	-15.32	Average
10	1.34	31.72	0.22	31.94	56.00	-24.06	QP
11	4.80	16.26	0.38	16.64	46.00	-29.36	Average
12	4.80	22.59	0.38	22.97	56.00	-33.03	QP

Notes:

1. Result = Read Value + Factor
2. Factor = LISN Factor + Cable Loss
3. All emission below 1GHz at 802.11b/g/n mode are all the same,so the 802.11g/n mode chosen as representative in final test.
4. According to technical experiences,all spurious emission of 802.11g/n mode at channel 1,6,11 or 3,6,9(for HT40) are almost the same below 1GHz,so that the channel 1 or 3(for HT40)was chosen as representative in final test.
5. The data is worse case.



Power	: From System	Pol/Phase	: NEUTRAL
Test Mode 2	: 802.11n HT20, CH1	Temperature	: 25 °C
Test Date	: Aug. 09, 2012	Humidity	: 65 %

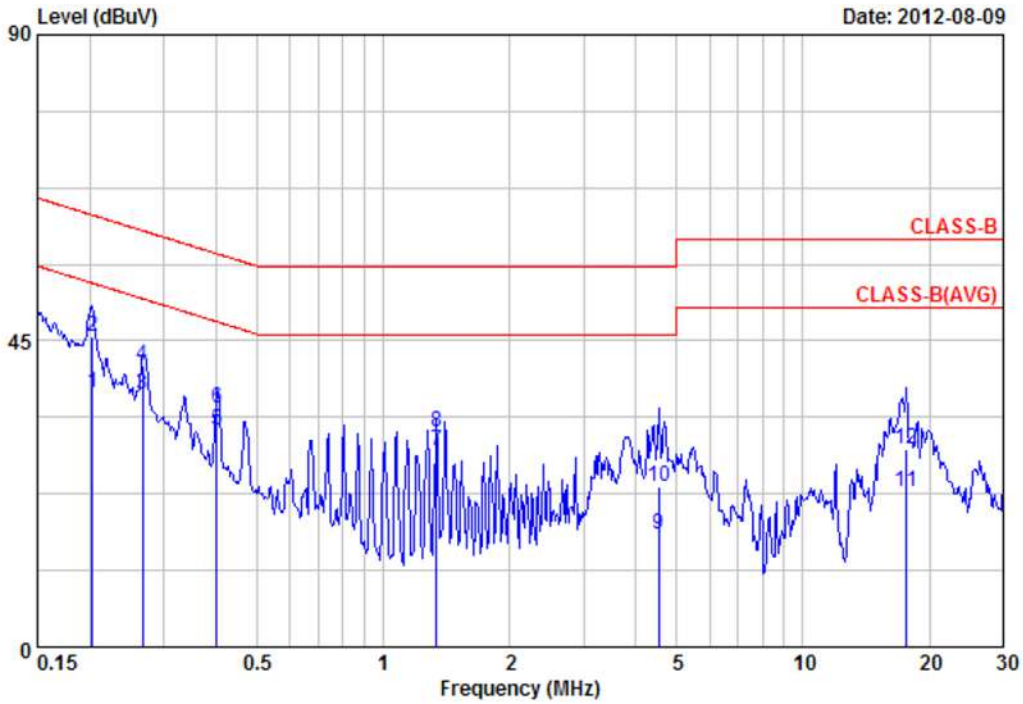

Item	Freq	Read Value	Factor	Result	Limit	Margin	Remark
	MHz	dBuV	dB/m	dBuV/m	dBuV/m	dB	
1	0.20	37.13	0.10	37.23	53.49	-16.26	Average
2	0.20	45.58	0.10	45.68	63.49	-17.81	QP
3	0.27	37.11	0.10	37.21	51.20	-13.99	Average
4	0.27	41.33	0.10	41.43	61.20	-19.77	QP
5	0.40	31.82	0.12	31.94	47.81	-15.87	Average
6	0.40	34.96	0.12	35.08	57.81	-22.73	QP
7	1.34	28.62	0.20	28.82	46.00	-17.18	Average
8	1.34	31.50	0.20	31.70	56.00	-24.30	QP
9	4.53	16.20	0.34	16.54	46.00	-29.46	Average
10	4.53	23.25	0.34	23.59	56.00	-32.41	QP
11	17.59	22.24	0.69	22.93	50.00	-27.07	Average
12	17.59	28.45	0.69	29.14	60.00	-30.86	QP

Notes:

1. Result = Read Value + Factor
2. Factor = LISN Factor + Cable Loss
3. All emission below 1GHz at 802.11b/g/n mode are all the same, so the 802.11g/n mode chosen as representative in final test.
4. According to technical experiences, all spurious emission of 802.11g/n mode at channel 1, 6, 11 or 3, 6, 9 (for HT40) are almost the same below 1GHz, so that the channel 1 or 3 (for HT40) was chosen as representative in final test.
5. The data is worse case.



Power	: From System	Pol/Phase	: LINE
Test Mode 3	: 802.11n HT40, CH3	Temperature	: 25 °C
Test Date	: Aug. 09, 2012	Humidity	: 65 %

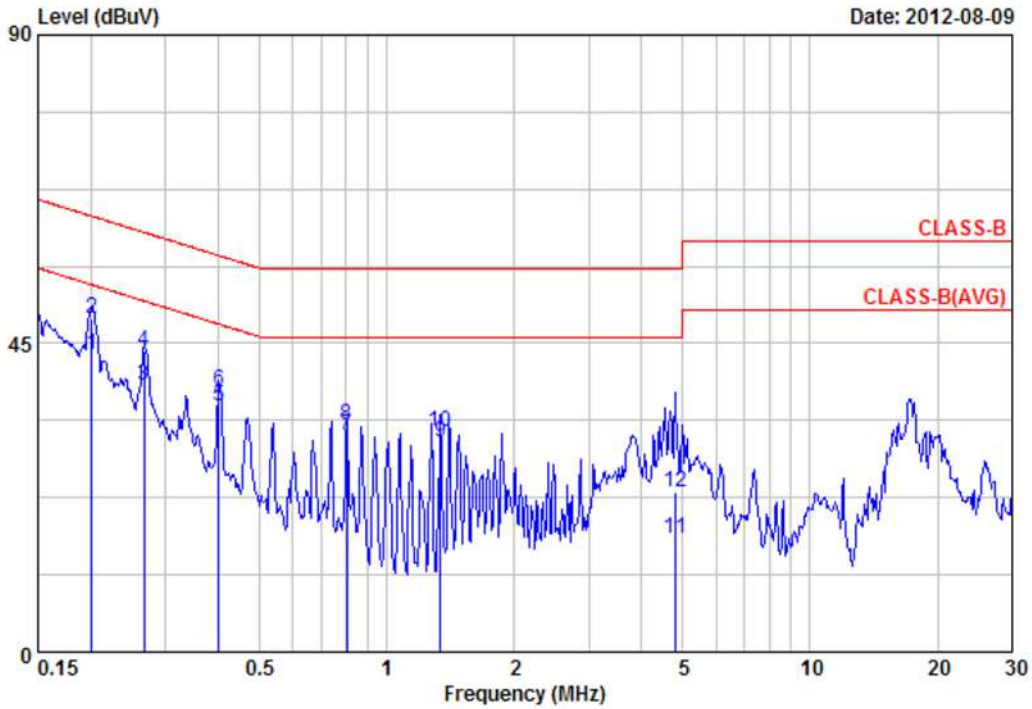

Item	Freq	Read Value	Factor	Result	Limit	Margin	Remark
	MHz	dBuV	dB/m	dBuV/m	dBuV/m	dB	
1	0.20	43.14	0.12	43.26	53.58	-10.32	Average
2	0.20	48.45	0.12	48.57	63.58	-15.01	QP
3	0.27	38.79	0.12	38.91	51.20	-12.29	Average
4	0.27	43.63	0.12	43.75	61.20	-17.45	QP
5	0.40	35.64	0.13	35.77	47.81	-12.04	Average
6	0.40	37.91	0.13	38.04	57.81	-19.77	QP
7	0.80	31.43	0.18	31.61	46.00	-14.39	Average
8	0.80	32.97	0.18	33.15	56.00	-22.85	QP
9	1.34	30.49	0.22	30.71	46.00	-15.29	Average
10	1.34	31.77	0.22	31.99	56.00	-24.01	QP
11	4.80	16.23	0.38	16.61	46.00	-29.39	Average
12	4.80	22.89	0.38	23.27	56.00	-32.73	QP

Notes:

1. Result = Read Value + Factor
2. Factor = LISN Factor + Cable Loss
3. All emission below 1GHz at 802.11b/g/n mode are all the same,so the 802.11g/n mode chosen as representative in final test.
4. According to technical experiences,all spurious emission of 802.11g/n mode at channel 1,6,11 or 3,6,9(for HT40) are almost the same below 1GHz,so that the channel 1 or 3(for HT40)was chosen as representative in final test.
5. The data is worse case.



Power	: From System	Pol/Phase	: NEUTRAL
Test Mode 3	: 802.11n HT40, CH3	Temperature	: 25 °C
Test Date	: Aug. 09, 2012	Humidity	: 65 %

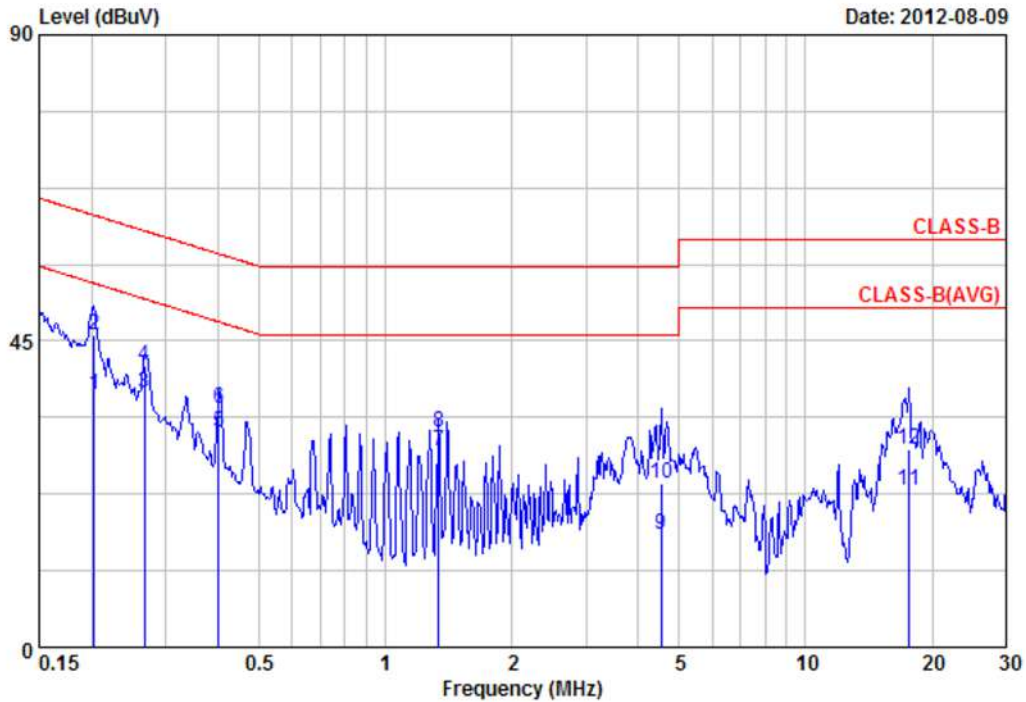

Item	Freq	Read Value	Factor	Result	Limit	Margin	Remark
	MHz	dBuV	dB/m	dBuV/m	dBuV/m	dB	
1	0.20	37.10	0.10	37.20	53.49	-16.29	Average
2	0.20	45.66	0.10	45.76	63.49	-17.73	QP
3	0.27	37.36	0.10	37.46	51.20	-13.74	Average
4	0.27	41.36	0.10	41.46	61.20	-19.74	QP
5	0.40	31.58	0.12	31.70	47.81	-16.11	Average
6	0.40	34.94	0.12	35.06	57.81	-22.75	QP
7	1.34	28.52	0.20	28.72	46.00	-17.28	Average
8	1.34	31.44	0.20	31.64	56.00	-24.36	QP
9	4.53	16.20	0.34	16.54	46.00	-29.46	Average
10	4.53	23.64	0.34	23.98	56.00	-32.02	QP
11	17.59	22.28	0.69	22.97	50.00	-27.03	Average
12	17.59	28.46	0.69	29.15	60.00	-30.85	QP

Notes:

1. Result = Read Value + Factor
2. Factor = LISN Factor + Cable Loss
3. All emission below 1GHz at 802.11b/g/n mode are all the same, so the 802.11g/n mode chosen as representative in final test.
4. According to technical experiences, all spurious emission of 802.11g/n mode at channel 1, 6, 11 or 3, 6, 9 (for HT40) are almost the same below 1GHz, so that the channel 1 or 3 (for HT40) was chosen as representative in final test.
5. The data is worse case.



5. Test of Radiated Emission

5.1 Test Limit

In any 100kHz bandwidth outside the frequency band in which the spread spectrum or digitally modulated intentional radiator is operating, the radio frequency power that is produced by the intentional radiator shall be at least 20dB below that in the 100kHz bandwidth within the band that contains the highest level of the desired power, based on either an RF conducted or a radiated measurement. If the transmitter measurement is based on the maximum conducted output power, the attenuation required under this paragraph shall be 30dB instead of 20dB. In addition, radiated emissions which fall in section 15.205(a) the restricted bands must also comply with the radiated emission limit specified in section 15.209(a).

Frequency (MHz)	Field Strength (microvolt/meter)	Measurement Distance (meters)
0.009 ~ 0.490	2400/F(kHz)	300
0.490 ~ 1.705	24000/F(kHz)	30
1.705 ~ 30.0	30	30
30 ~ 88	100	3
88 ~ 216	150	3
216 ~ 960	200	3
Above 960	500	3

5.2 Test Procedures

- The EUT was placed on a rotatable table top 0.8 meter above ground.
- The EUT was set 3 meters from the interference receiving antenna which was mounted on the top of a variable height antenna tower.
- The table was rotated 360 degrees to determine the position of the highest radiation.
- The antenna is a broadband antenna and its height is varied between one meter and four meters above ground to find the maximum value of the field strength both horizontal polarization and vertical polarization of the antenna are set to make the measurement.
- For each suspected emission the EUT was arranged to its worst case and then tune the antenna tower (from 1 M to 4 M) and turn table (from 0 degree to 360 degrees) to find the maximum reading.
- Set the test-receiver system to Peak or CISPR quasi-peak Detect Function and specified bandwidth with Maximum Hold Mode.
- If the emission level of the EUT in peak mode was 3 dB lower than the limit specified, then testing will be stopped and peak values of EUT will be reported, otherwise, the emissions which do not have 3 dB margin will be repeated one by one using the quasi-peak method and reported.
- For testing above 1GHz, the emission level of the EUT in peak mode was 20dB lower than average limit (that means the emission level in peak mode also complies with the limit in average mode), then testing will be stopped and peak values of EUT will be reported, otherwise, the emissions will be measured in average mode again and reported.
- “Cone of radiation” has been considered to be 3dB bandwidth of the measurement antenna.

5.3 Typical Test Setup

For radiated emissions below 30MHz

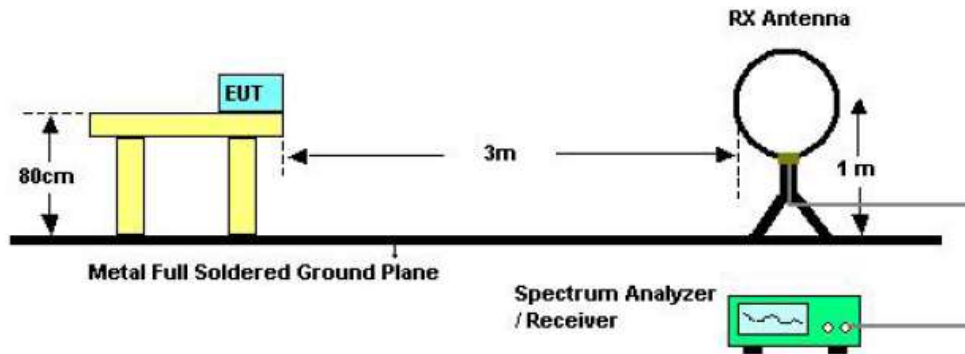

For radiated emissions above 30MHz

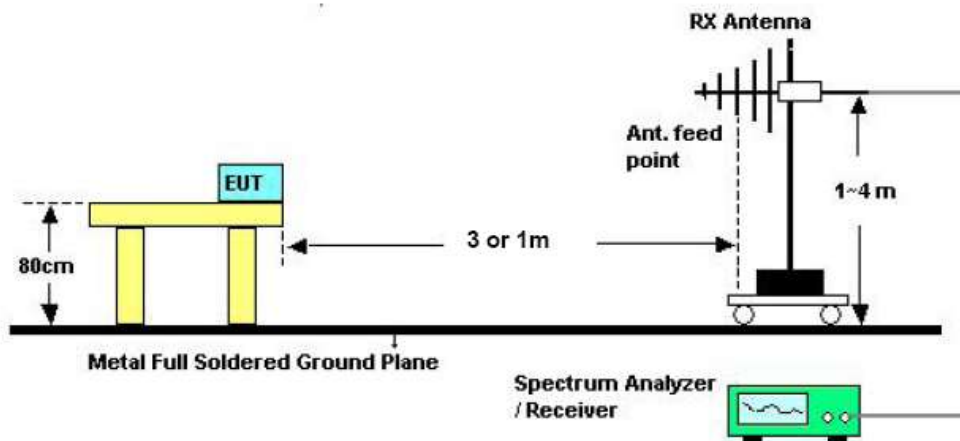

Above 10 GHz shall be extrapolated to the specified distance using an extrapolation factor of 20 dB/decade from 3m to 1m.

Distance extrapolation factor = $20 \log(\text{specific distance [3m]} / \text{test distance [1m]})$ (dB);
 Limit line = specific limits (dBuV) + distance extrapolation factor [9.54 dB].

5.4 Measurement Equipment

Instrument/Ancillary	Manufacturer	Model No.	Serial No.	Calibration Date	Valid Date
EMI Receiver	R&S	ESCI	100821	2012/01/31	2013/01/30
Amplifier	QuieTek	AP/0100A	CHM0906075	2012/01/13	2013/01/12
Signal Generator	HP	8648B	3629U00612	2012/01/11	2013/01/10
Bilog Antenna	Schwarzbeck	VULB 9168	275	2012/03/23	2013/03/22
Spectrum Analyzer	R&S	FSP40	100047	2012/03/01	2013/02/28
Horn Antenna	EMCO	3115	31589	2012/03/01	2013/02/28
Preamplifier	Agilent	8449B	3008A01954	2012/02/29	2013/02/28
Loop Antenna	EMCO	6507	40855	2012/02/29	2013/02/28



5.5 Test Result and Data (9kHz ~ 30MHz)

The 9kHz - 30MHz spurious emission is under limit 20dB more.

5.6 Test Result and Data

Power	:	From system	Pol/Phase	:	VERTICAL
Test Mode 1	:	802.11g, CH1	Temperature	:	23 °C
Memo	:		Humidity	:	65 %

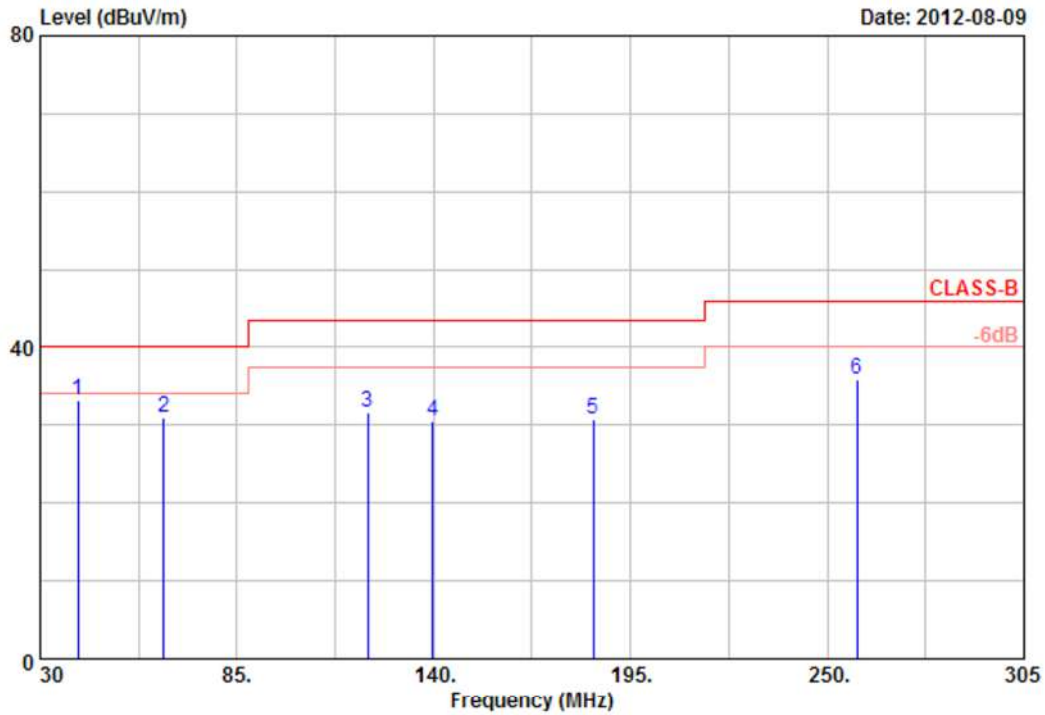

Item	Freq MHz	Read Value dBUV	Factor dB/m	Result dBUV/m	Limit dBUV/m	Margin dB	Remark	Ant Pos cm	Tab Pos Deg
1	40.45	34.62	-1.52	33.10	40.00	-6.90	Peak	100	360
2	64.65	42.76	-11.81	30.95	40.00	-9.05	Peak	100	360
3	121.58	36.40	-4.74	31.66	43.50	-11.84	Peak	100	360
4	139.75	38.04	-7.49	30.55	43.50	-12.95	Peak	100	360
5	184.52	43.87	-13.19	30.68	43.50	-12.82	Peak	100	360
6	258.25	43.76	-7.95	35.81	46.00	-10.19	Peak	100	360

Notes:

1. Result = Read Value + Factor
2. Factor = Antenna Factor + Cable Loss - Amplifier
3. The resolution bandwidth of test receiver/spectrum analyzer is 120KHz and video bandwidth is 300kHz for Peak detection and Quasi-peak detection at frequency below 1GHz.
4. All emission below 1GHz at 802.11g/n mode are all the same,so the 802.11g/n mode chosen as representative in final test.
5. According to technical experiences,all spurious emission of 802.11g/n mode at channel 1,6,11 or 3,6,9(for HT40) are almost the same below 1GHz,so that the channel 1 or 3(for HT40)was chosen as representative in final test.
6. The data is worse case.



Power	: From system	Pol/Phase	: VERTICAL
Test Mode 1	: 802.11g, CH1	Temperature	: 23 °C
Memo	:	Humidity	: 65 %

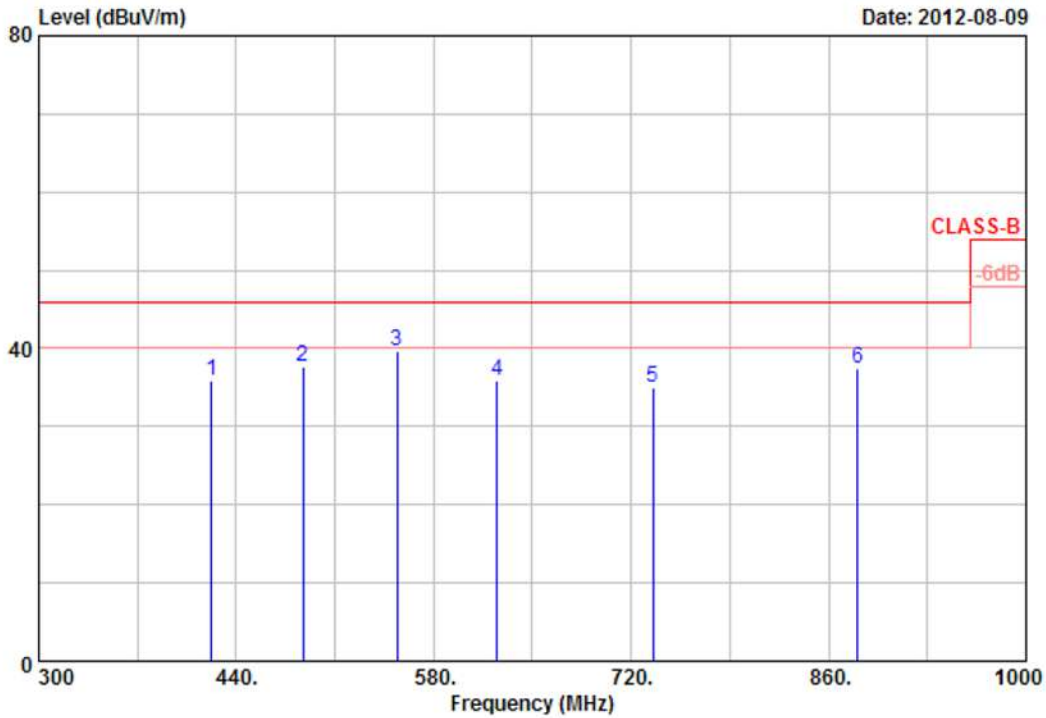

Item	Freq MHz	Read Value dBuV	Factor dB/m	Result dBuV/m	Limit dBuV/m	Margin dB	Remark	Ant Pos cm	Tab Pos Deg
1	422.50	40.51	-4.55	35.96	46.00	-10.04	Peak	100	0
2	487.62	43.21	-5.59	37.62	46.00	-8.38	Peak	100	0
3	554.20	32.55	7.07	39.62	46.00	-6.38	Peak	100	0
4	624.80	35.21	0.64	35.85	46.00	-10.15	Peak	100	0
5	735.39	28.37	6.63	35.00	46.00	-11.00	Peak	100	0
6	880.30	27.29	10.07	37.36	46.00	-8.64	Peak	100	0

Notes:

1. Result = Read Value + Factor
2. Factor = Antenna Factor + Cable Loss - Amplifier
3. The resolution bandwidth of test receiver/spectrum analyzer is 120KHz and video bandwidth is 300kHz for Peak detection and Quasi-peak detection at frequency below 1GHz.
4. All emission below 1GHz at 802.11b/g/n mode are all the same, so the 802.11g/n mode chosen as representative in final test.
5. According to technical experiences, all spurious emission of 802.11g/n mode at channel 1, 6, 11 or 3, 6, 9 (for HT40) are almost the same below 1GHz, so that the channel 1 or 3 (for HT40) was chosen as representative in final test.
6. The data is worse case.



Power	: From system	Pol/Phase	: HORIZONTAL
Test Mode 1	: 802.11g, CH1	Temperature	: 23 °C
Memo	:	Humidity	: 65 %

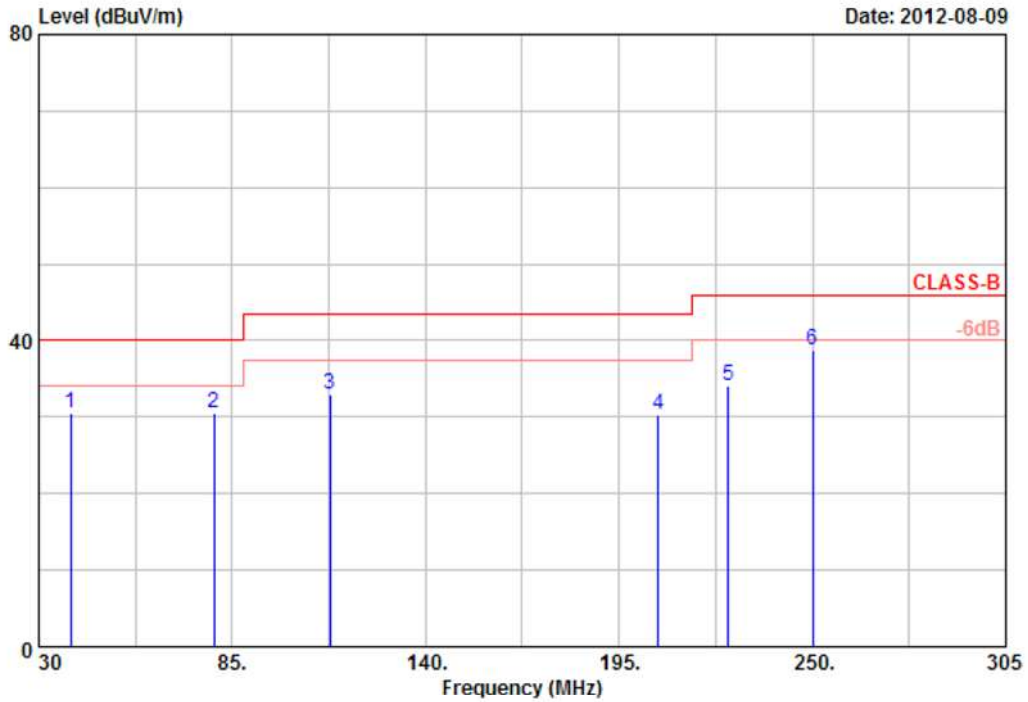

Item	Freq	Read Value	Factor	Result	Limit	Margin	Remark	Ant Pos	Tab Pos
	MHz	dBuV	dB/m	dBuV/m	dBuV/m	dB		cm	Deg
1	39.08	37.89	-7.27	30.62	40.00	-9.38	Peak	100	360
2	79.78	49.36	-18.73	30.63	40.00	-9.37	Peak	100	360
3	112.77	52.05	-18.99	33.06	43.50	-10.44	Peak	100	360
4	206.27	48.75	-18.34	30.41	43.50	-13.09	Peak	100	360
5	226.08	48.98	-14.98	34.00	46.00	-12.00	Peak	100	360
6	249.99	52.28	-13.52	38.76	46.00	-7.24	Peak	100	360

Notes:

1. Result = Read Value + Factor
2. Factor = Antenna Factor + Cable Loss - Amplifier
3. The resolution bandwidth of test receiver/spectrum analyzer is 120KHz and video bandwidth is 300kHz for Peak detection and Quasi-peak detection at frequency below 1GHz.
4. All emission below 1GHz at 802.11b/g/n mode are all the same, so the 802.11g/n mode chosen as representative in final test.
5. According to technical experiences, all spurious emission of 802.11g/n mode at channel 1,6,11 or 3,6,9(for HT40) are almost the same below 1GHz, so that the channel 1 or 3(for HT40) was chosen as representative in final test.
6. The data is worse case.



Power	: From system	Pol/Phase	: HORIZONTAL
Test Mode 1	: 802.11g, CH1	Temperature	: 23 °C
Memo	:	Humidity	: 65 %

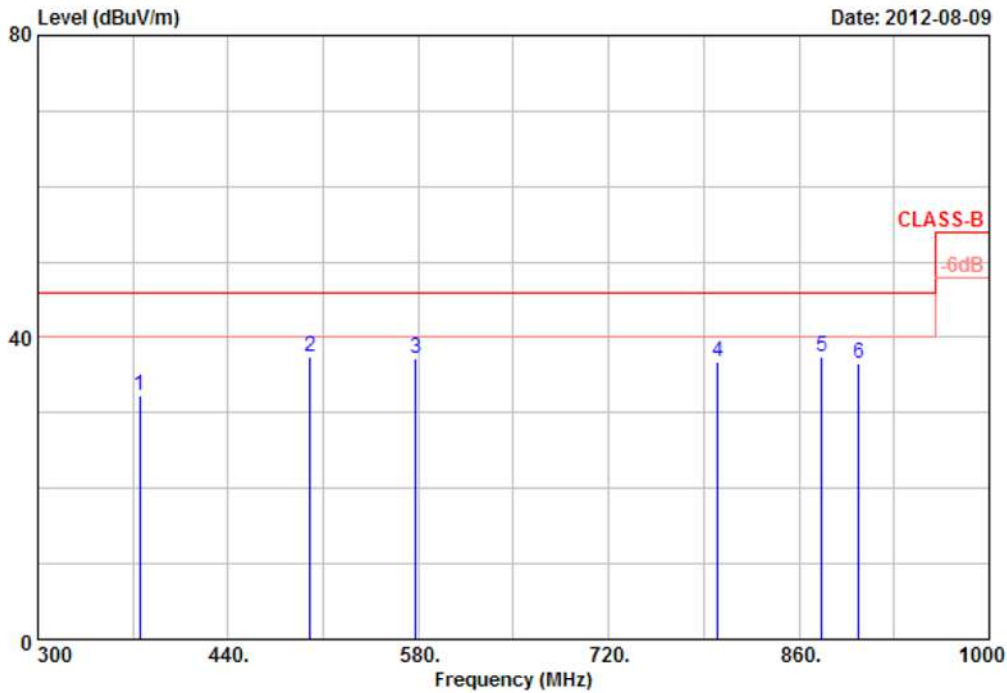

Item	Freq	Read Value	Factor	Result	Limit	Margin	Remark	Ant Pos	Tab Pos
	MHz	dBuV	dB/m	dBuV/m	dBuV/m	dB		cm	Deg
1	374.89	44.03	-11.64	32.39	46.00	-13.61	Peak	100	0
2	500.20	37.63	-0.11	37.52	46.00	-8.48	Peak	100	0
3	577.89	34.94	2.31	37.25	46.00	-8.75	Peak	100	0
4	800.50	30.56	6.14	36.70	46.00	-9.30	Peak	100	0
5	876.80	32.29	5.12	37.41	46.00	-8.59	Peak	100	0
6	904.10	31.53	5.10	36.63	46.00	-9.37	Peak	100	0

Notes:

1. Result = Read Value + Factor
2. Factor = Antenna Factor + Cable Loss - Amplifier
3. The resolution bandwidth of test receiver/spectrum analyzer is 120KHz and video bandwidth is 300kHz for Peak detection and Quasi-peak detection at frequency below 1GHz.
4. All emission below 1GHz at 802.11b/g/n mode are all the same, so the 802.11g/n mode chosen as representative in final test.
5. According to technical experiences, all spurious emission of 802.11g/n mode at channel 1,6,11 or 3,6,9(for HT40) are almost the same below 1GHz, so that the channel 1 or 3(for HT40) was chosen as representative in final test.
6. The data is worse case.



Power	: From system	Pol/Phase	: VERTICAL
Test Mode 1	: 802.11b, CH1	Temperature	: 23 °C
Memo	:	Humidity	: 65 %

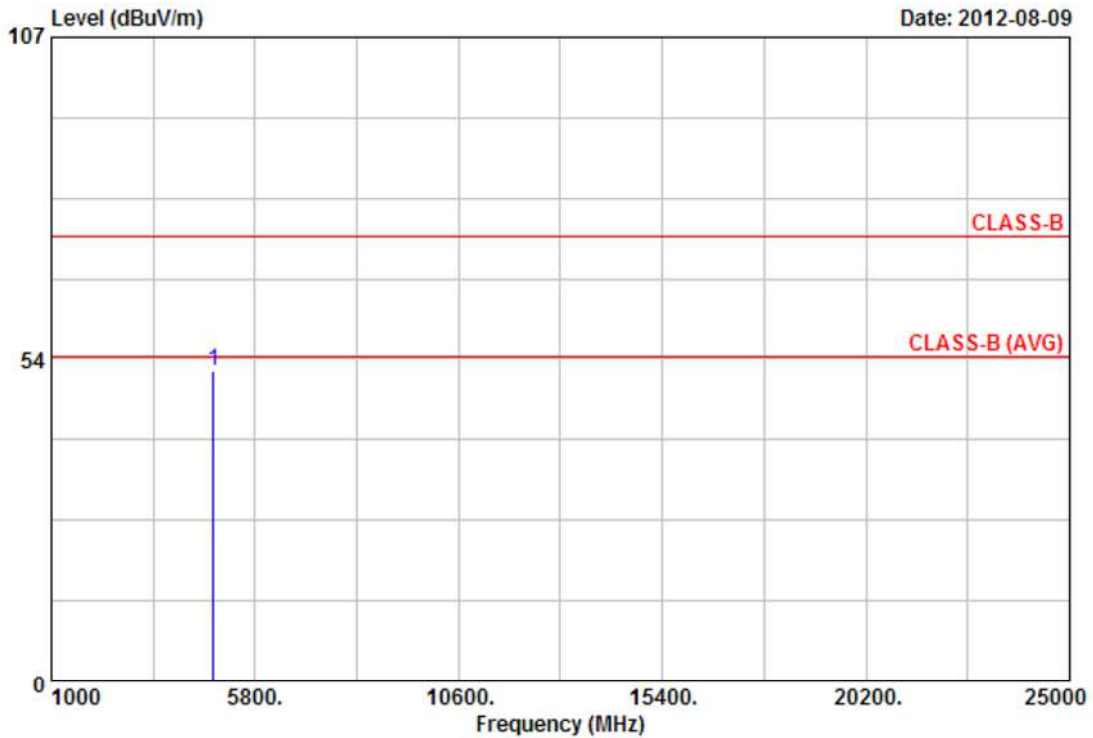

Item	Freq	Read Value	Factor	Result	Limit	Margin	Remark	Ant Pos	Tab Pos
	MHz	dBuV	dB/m	dBuV/m	dBuV/m	dB		cm	Deg
1	4823.75	46.15	5.36	51.51	74.00	-22.49	Peak	100	54

Notes:

1. Result = Read Value + Factor
2. Factor = Antenna Factor + Cable Loss - Amplifier
3. The resolution bandwidth of test receiver/spectrum analyzer is 120KHz and video bandwidth is 300kHz for Peak detection and Quasi-peak detection at frequency below 1GHz.
4. The resolution bandwidth of test receiver/spectrum analyzer is 1MHz and video bandwidth is 3MHz for Peak detection at frequency above 1GHz.
5. The resolution bandwidth of test receiver/spectrum analyzer is 1MHz and video bandwidth is 3MHz (detector sample mode) for Average detection at frequency above 1GHz.
6. The other emissions is too low to be measured. (The worst case noise floor measurements value is 47.93 dBuV at 16.10GHz)
7. The data is worse case.



Power	: From system	Pol/Phase	: HORIZONTAL
Test Mode 1	: 802.11b, CH1	Temperature	: 23 °C
Memo	:	Humidity	: 65 %

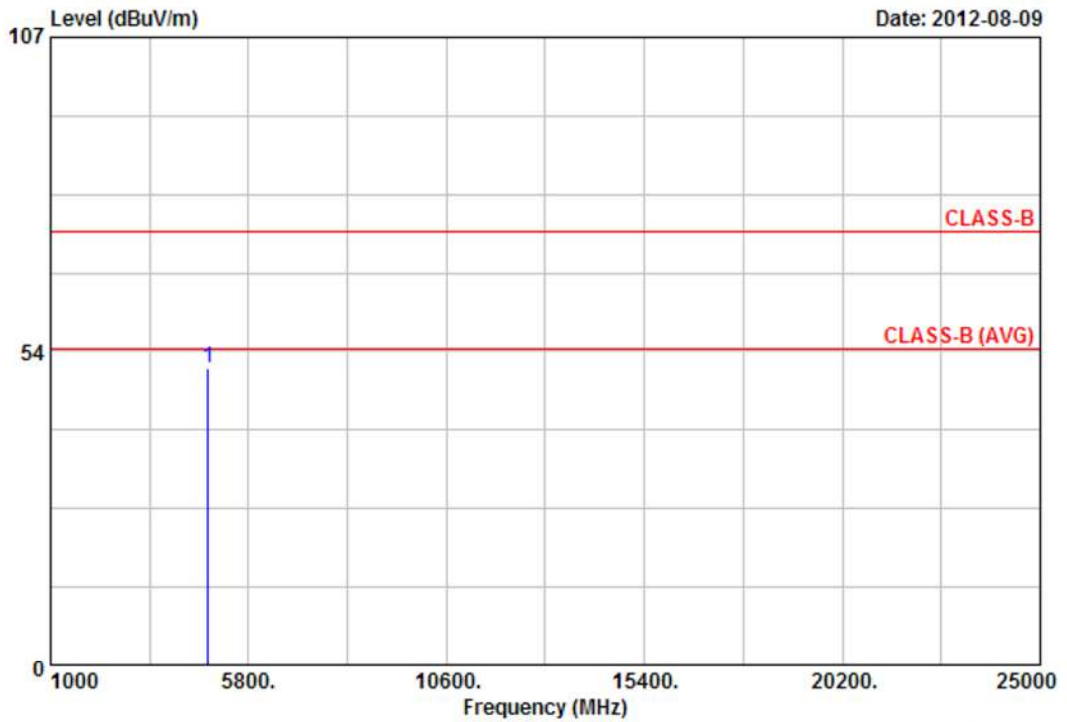

Item	Freq	Read Value	Factor	Result	Limit	Margin	Remark	Ant Pos	Tab Pos
	MHz	dBuV	dB/m	dBuV/m	dBuV/m	dB		cm	Deg
1	4821.63	46.86	3.68	50.54	74.00	-23.46	Peak	100	0

Notes:

1. Result = Read Value + Factor
2. Factor = Antenna Factor + Cable Loss - Amplifier
3. The resolution bandwidth of test receiver/spectrum analyzer is 120KHz and video bandwidth is 300KHz for Peak detection and Quasi-peak detection at frequency below 1GHz.
4. The resolution bandwidth of test receiver/spectrum analyzer is 1MHz and video bandwidth is 3MHz for Peak detection at frequency above 1GHz.
5. The resolution bandwidth of test receiver/spectrum analyzer is 1MHz and video bandwidth is 3MHz (detector sample mode) for Average detection at frequency above 1GHz.
6. The other emissions is too low to be measured. (The worst case noise floor measurements value is 47.93 dBuV at 16.10GHz)
7. The data is worse case.



Power	: From system	Pol/Phase	: VERTICAL
Test Mode 1	: 802.11b, CH6	Temperature	: 23 °C
Memo	:	Humidity	: 65 %

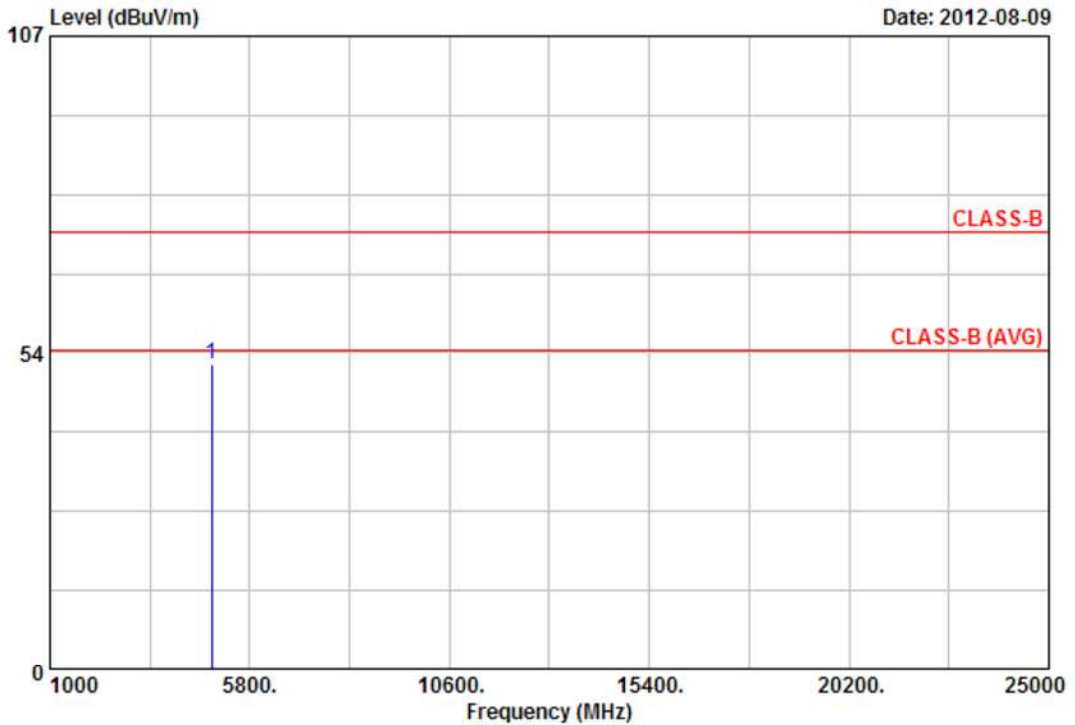

Item	Freq	Read Value	Factor	Result	Limit	Margin	Remark	Ant Pos	Tab Pos
	MHz	dBuV	dB/m	dBuV/m	dBuV/m	dB		cm	Deg
1	4874.00	45.23	6.36	51.59	74.00	-22.41	Peak	100	360

Notes:

1. Result = Read Value + Factor
2. Factor = Antenna Factor + Cable Loss - Amplifier
3. The resolution bandwidth of test receiver/spectrum analyzer is 120KHz and video bandwidth is 300kHz for Peak detection and Quasi-peak detection at frequency below 1GHz.
4. The resolution bandwidth of test receiver/spectrum analyzer is 1MHz and video bandwidth is 3MHz for Peak detection at frequency above 1GHz.
5. The resolution bandwidth of test receiver/spectrum analyzer is 1MHz and video bandwidth is 3MHz (detector sample mode) for Average detection at frequency above 1GHz.
6. The other emissions is too low to be measured. (The worst case noise floor measurements value is 47.93 dBuV at 16.10GHz)
7. The data is worse case.



Power	: From system	Pol/Phase	: HORIZONTAL
Test Mode 1	: 802.11b, CH6	Temperature	: 23 °C
Memo	:	Humidity	: 65 %

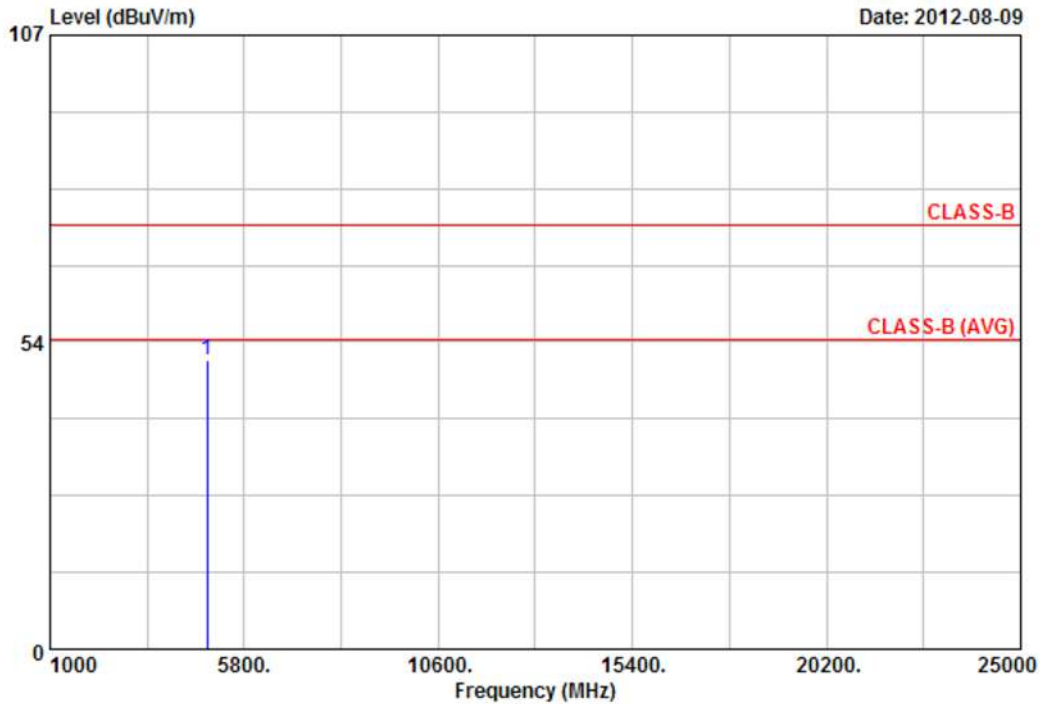

Item	Freq	Read Value	Factor	Result	Limit	Margin	Remark	Ant Pos	Tab Pos
	MHz	dBuV	dB/m	dBuV/m	dBuV/m	dB		cm	Deg
1	4874.00	45.82	4.50	50.32	74.00	-23.68	Peak	100	118

Notes:

1. Result = Read Value + Factor
2. Factor = Antenna Factor + Cable Loss - Amplifier
3. The resolution bandwidth of test receiver/spectrum analyzer is 120KHz and video bandwidth is 300kHz for Peak detection and Quasi-peak detection at frequency below 1GHz.
4. The resolution bandwidth of test receiver/spectrum analyzer is 1MHz and video bandwidth is 3MHz for Peak detection at frequency above 1GHz.
5. The resolution bandwidth of test receiver/spectrum analyzer is 1MHz and video bandwidth is 3MHz (detector sample mode) for Average detection at frequency above 1GHz.
6. The other emissions is too low to be measured. (The worst case noise floor measurements value is 47.93 dBuV at 16.10GHz)
7. The data is worse case.



Power	: From system	Pol/Phase	: VERTICAL
Test Mode 1	: 802.11b, CH11	Temperature	: 23 °C
Memo	:	Humidity	: 65 %

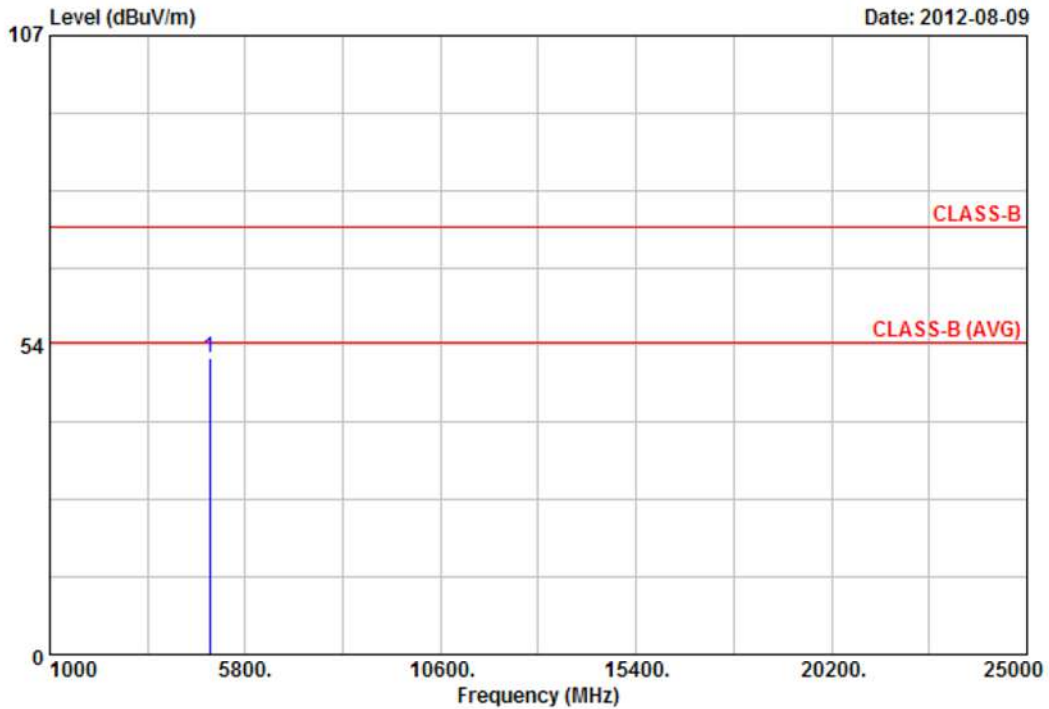

Item	Freq	Read Value	Factor	Result	Limit	Margin	Remark	Ant Pos	Tab Pos
	MHz	dBuV	dB/m	dBuV/m	dBuV/m	dB		cm	Deg
1	4923.88	44.45	6.94	51.39	74.00	-22.61	Peak	100	214

Notes:

1. Result = Read Value + Factor
2. Factor = Antenna Factor + Cable Loss - Amplifier
3. The resolution bandwidth of test receiver/spectrum analyzer is 120KHz and video bandwidth is 300kHz for Peak detection and Quasi-peak detection at frequency below 1GHz.
4. The resolution bandwidth of test receiver/spectrum analyzer is 1MHz and video bandwidth is 3MHz for Peak detection at frequency above 1GHz.
5. The resolution bandwidth of test receiver/spectrum analyzer is 1MHz and video bandwidth is 3MHz (detector sample mode) for Average detection at frequency above 1GHz.
6. The other emissions is too low to be measured. (The worst case noise floor measurements value is 47.93 dBuV at 16.10GHz)
7. The data is worse case.



Power	: From system	Pol/Phase	: HORIZONTAL
Test Mode 1	: 802.11b, CH11	Temperature	: 23 °C
Memo	:	Humidity	: 65 %

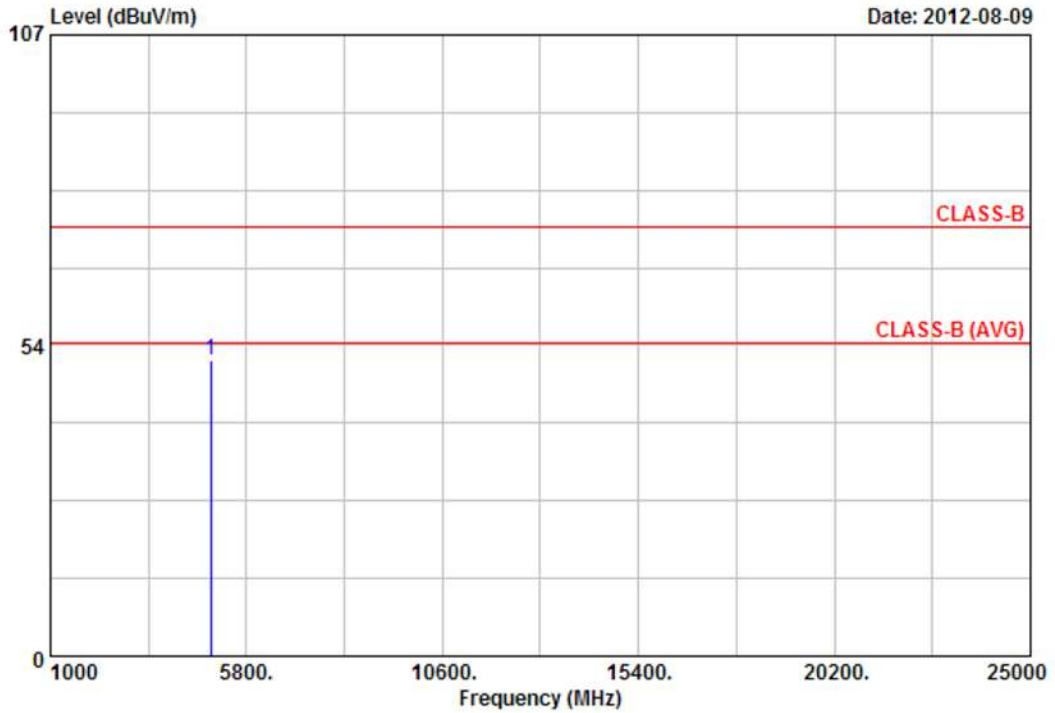

Item	Freq	Read Value	Factor	Result	Limit	Margin	Remark	Ant Pos	Tab Pos
	MHz	dBuV	dB/m	dBuV/m	dBuV/m	dB		cm	Deg
1	4923.88	45.89	4.93	50.82	74.00	-23.18	Peak	100	330

Notes:

1. Result = Read Value + Factor
2. Factor = Antenna Factor + Cable Loss - Amplifier
3. The resolution bandwidth of test receiver/spectrum analyzer is 120KHz and video bandwidth is 300kHz for Peak detection and Quasi-peak detection at frequency below 1GHz.
4. The resolution bandwidth of test receiver/spectrum analyzer is 1MHz and video bandwidth is 3MHz for Peak detection at frequency above 1GHz.
5. The resolution bandwidth of test receiver/spectrum analyzer is 1MHz and video bandwidth is 3MHz (detector sample mode) for Average detection at frequency above 1GHz.
6. The other emissions is too low to be measured. (The worst case noise floor measurements value is 47.93 dBuV at 16.10GHz)
7. The data is worse case.



Power	: From system	Pol/Phase	: VERTICAL
Test Mode 1	: 802.11g, CH1	Temperature	: 23 °C
Memo	:	Humidity	: 65 %

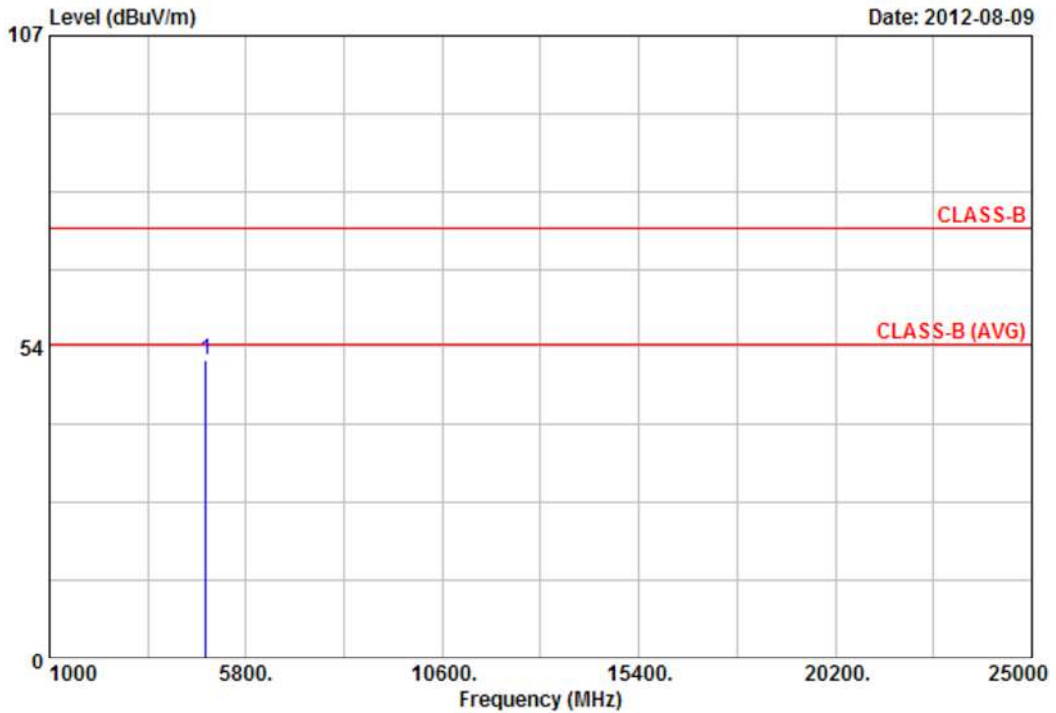

Item	Freq	Read Value	Factor	Result	Limit	Margin	Remark	Ant Pos	Tab Pos
	MHz	dBuV	dB/m	dBuV/m	dBuV/m	dB		cm	Deg
1	4824.00	45.79	5.37	51.16	74.00	-22.84	Peak	102	360

Notes:

1. Result = Read Value + Factor
2. Factor = Antenna Factor + Cable Loss - Amplifier
3. The resolution bandwidth of test receiver/spectrum analyzer is 120KHz and video bandwidth is 300kHz for Peak detection and Quasi-peak detection at frequency below 1GHz.
4. The resolution bandwidth of test receiver/spectrum analyzer is 1MHz and video bandwidth is 3MHz for Peak detection at frequency above 1GHz.
5. The resolution bandwidth of test receiver/spectrum analyzer is 1MHz and video bandwidth is 3MHz (detector sample mode) for Average detection at frequency above 1GHz.
6. The other emissions is too low to be measured. (The worst case noise floor measurements value is 47.93 dBuV at 16.10GHz)
7. The data is worse case.



Power	: From system	Pol/Phase	: HORIZONTAL
Test Mode 1	: 802.11g, CH1	Temperature	: 23 °C
Memo	:	Humidity	: 65 %

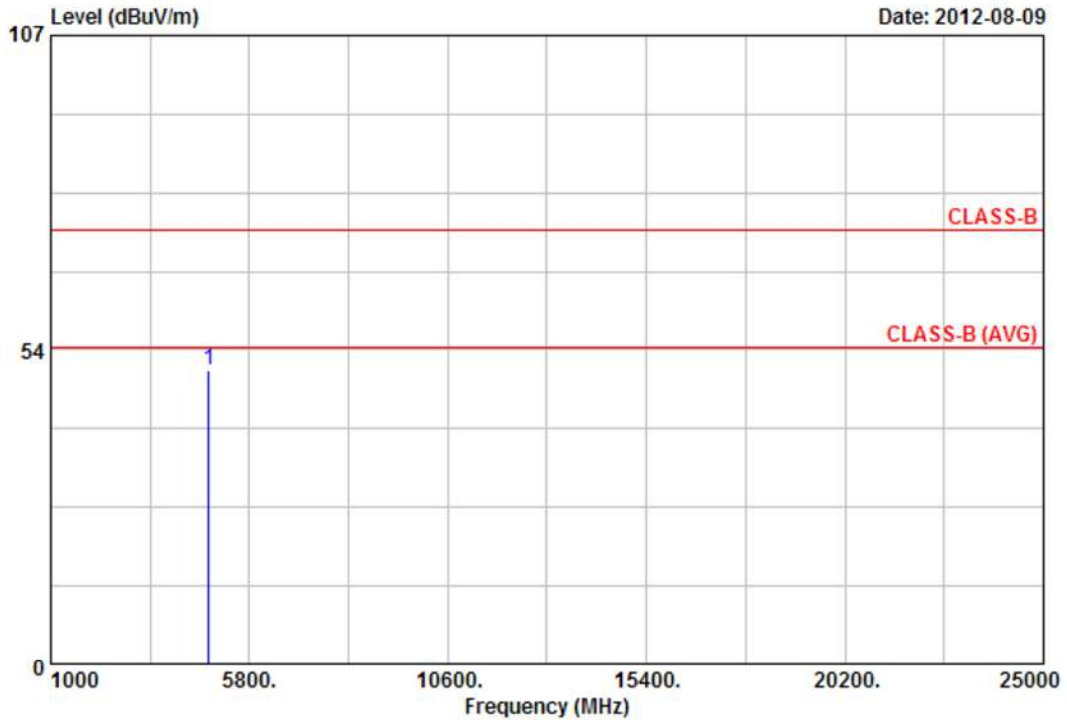

Item	Freq	Read Value	Factor	Result	Limit	Margin	Remark	Ant Pos	Tab Pos
	MHz	dBuV	dB/m	dBuV/m	dBuV/m	dB		cm	Deg
1	4824.00	46.30	3.71	50.01	74.00	-23.99	Peak	102	360

Notes:

1. Result = Read Value + Factor
2. Factor = Antenna Factor + Cable Loss - Amplifier
3. The resolution bandwidth of test receiver/spectrum analyzer is 120KHz and video bandwidth is 300kHz for Peak detection and Quasi-peak detection at frequency below 1GHz.
4. The resolution bandwidth of test receiver/spectrum analyzer is 1MHz and video bandwidth is 3MHz for Peak detection at frequency above 1GHz.
5. The resolution bandwidth of test receiver/spectrum analyzer is 1MHz and video bandwidth is 3MHz (detector sample mode) for Average detection at frequency above 1GHz.
6. The other emissions is too low to be measured. (The worst case noise floor measurements value is 47.93 dBuV at 16.10GHz)
7. The data is worse case.



Power	: From system	Pol/Phase	: VERTICAL
Test Mode 1	: 802.11g, CH6	Temperature	: 23 °C
Memo	:	Humidity	: 65 %

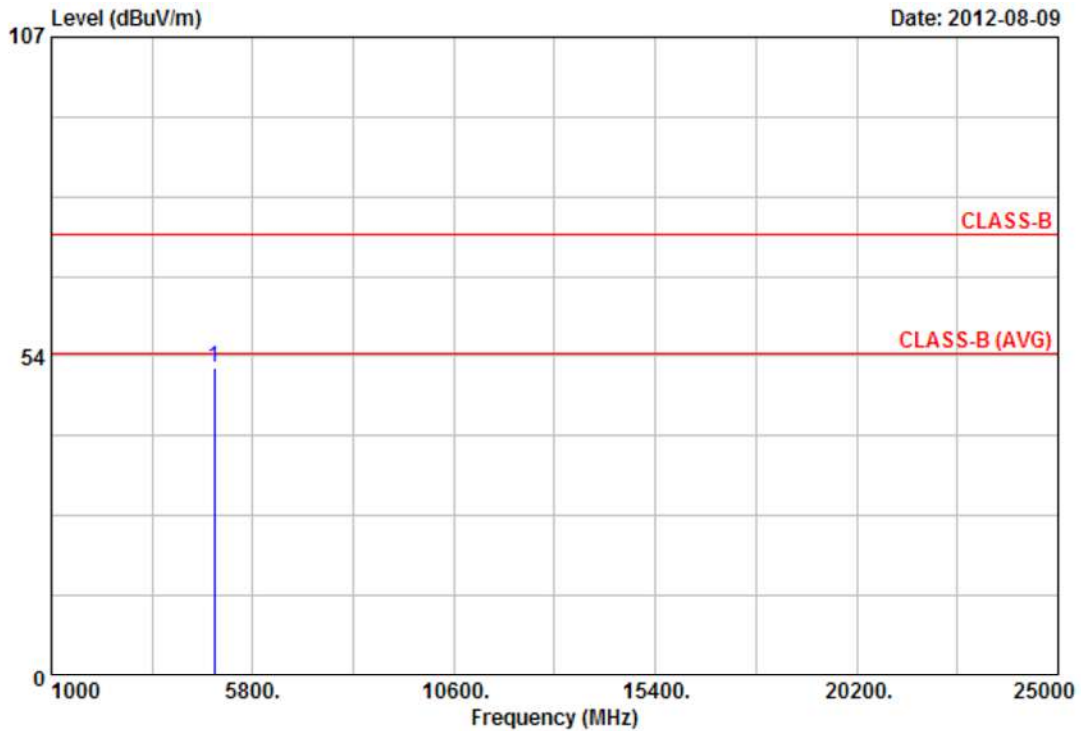

Item	Freq	Read Value	Factor	Result	Limit	Margin	Remark	Ant Pos	Tab Pos
	MHz	dBuV	dB/m	dBuV/m	dBuV/m	dB		cm	Deg
1	4874.00	45.33	6.36	51.69	74.00	-22.31	Peak	102	261

Notes:

1. Result = Read Value + Factor
2. Factor = Antenna Factor + Cable Loss - Amplifier
3. The resolution bandwidth of test receiver/spectrum analyzer is 120KHz and video bandwidth is 300kHz for Peak detection and Quasi-peak detection at frequency below 1GHz.
4. The resolution bandwidth of test receiver/spectrum analyzer is 1MHz and video bandwidth is 3MHz for Peak detection at frequency above 1GHz.
5. The resolution bandwidth of test receiver/spectrum analyzer is 1MHz and video bandwidth is 3MHz (detector sample mode) for Average detection at frequency above 1GHz.
6. The other emissions is too low to be measured. (The worst case noise floor measurements value is 47.93 dBuV at 16.10GHz)
7. The data is worse case.



Power	: From system	Pol/Phase	: HORIZONTAL
Test Mode 1	: 802.11g, CH6	Temperature	: 23 °C
Memo	:	Humidity	: 65 %

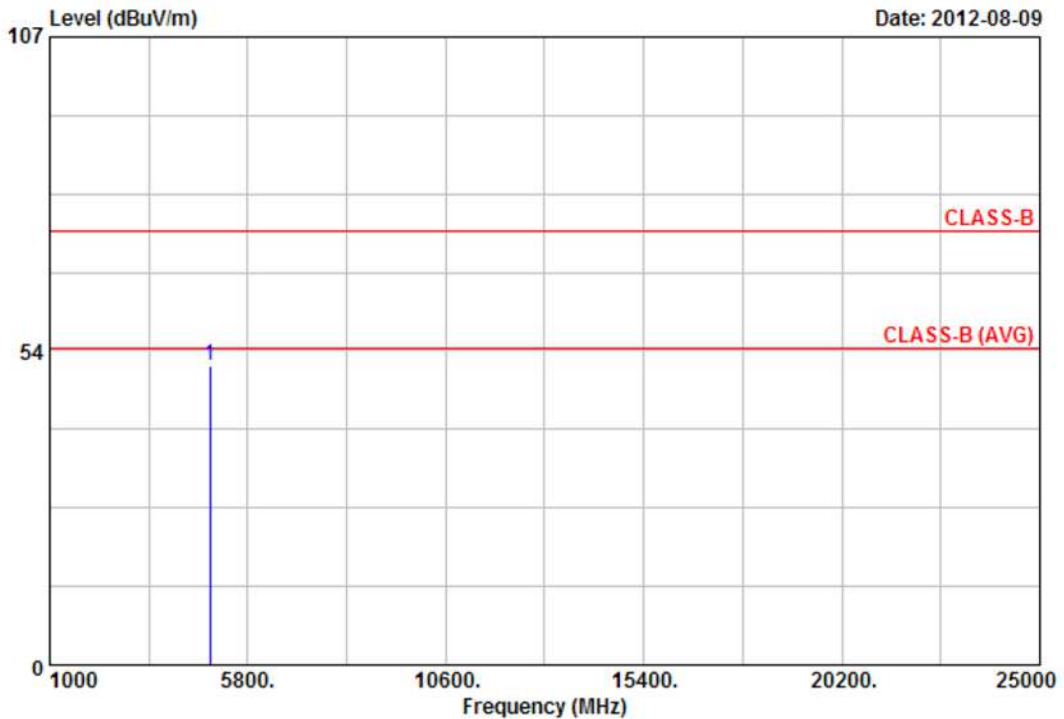

Item	Freq	Read Value	Factor	Result	Limit	Margin	Remark	Ant Pos	Tab Pos
	MHz	dBuV	dB/m	dBuV/m	dBuV/m	dB		cm	Deg
1	4874.00	46.42	4.50	50.92	74.00	-23.08	Peak	102	210

Notes:

1. Result = Read Value + Factor
2. Factor = Antenna Factor + Cable Loss - Amplifier
3. The resolution bandwidth of test receiver/spectrum analyzer is 120KHz and video bandwidth is 300kHz for Peak detection and Quasi-peak detection at frequency below 1GHz.
4. The resolution bandwidth of test receiver/spectrum analyzer is 1MHz and video bandwidth is 3MHz for Peak detection at frequency above 1GHz.
5. The resolution bandwidth of test receiver/spectrum analyzer is 1MHz and video bandwidth is 3MHz (detector sample mode) for Average detection at frequency above 1GHz.
6. The other emissions is too low to be measured. (The worst case noise floor measurements value is 47.93 dBuV at 16.10GHz)
7. The data is worse case.



Power	: From system	Pol/Phase	: VERTICAL
Test Mode 1	: 802.11g, CH11	Temperature	: 23 °C
Memo	:	Humidity	: 65 %

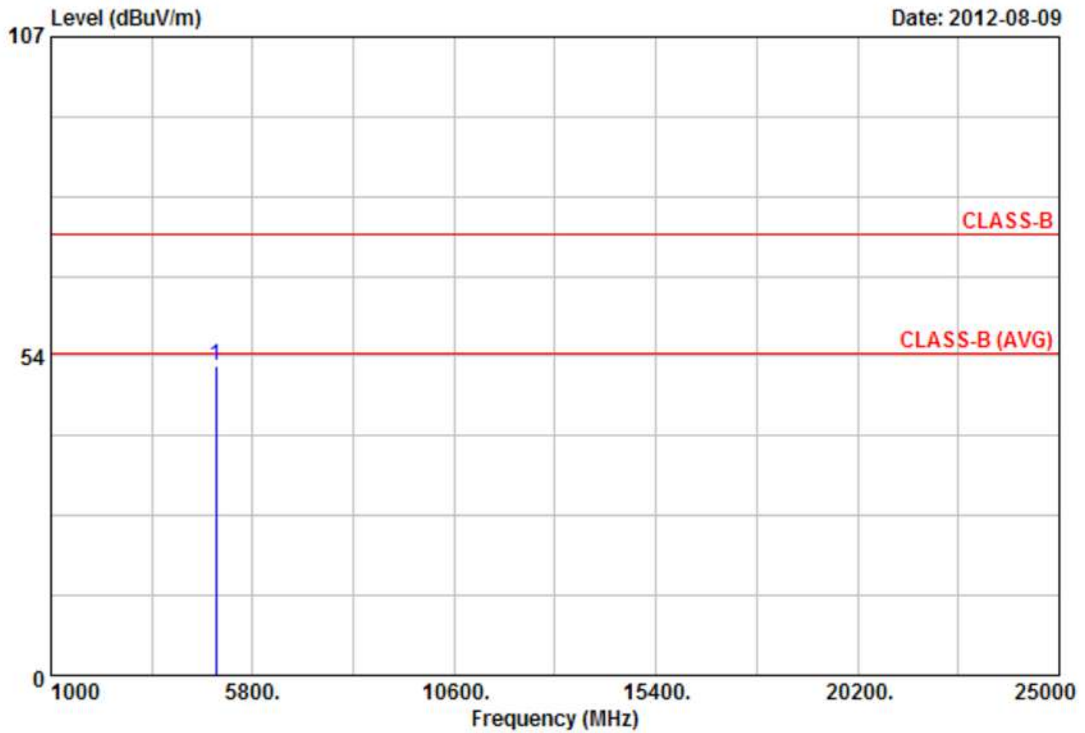

Item	Freq	Read Value	Factor	Result	Limit	Margin	Remark	Ant Pos	Tab Pos
	MHz	dBuV	dB/m	dBuV/m	dBuV/m	dB		cm	Deg
1	4924.00	44.79	6.94	51.73	74.00	-22.27	Peak	100	360

Notes:

1. Result = Read Value + Factor
2. Factor = Antenna Factor + Cable Loss - Amplifier
3. The resolution bandwidth of test receiver/spectrum analyzer is 120KHz and video bandwidth is 300KHz for Peak detection and Quasi-peak detection at frequency below 1GHz.
4. The resolution bandwidth of test receiver/spectrum analyzer is 1MHz and video bandwidth is 3MHz for Peak detection at frequency above 1GHz.
5. The resolution bandwidth of test receiver/spectrum analyzer is 1MHz and video bandwidth is 3MHz (detector sample mode) for Average detection at frequency above 1GHz.
6. The other emissions is too low to be measured. (The worst case noise floor measurements value is 47.93 dBuV at 16.10GHz)
7. The data is worse case.



Power	: From system	Pol/Phase	: HORIZONTAL
Test Mode 1	: 802.11g, CH11	Temperature	: 23 °C
Memo	:	Humidity	: 65 %

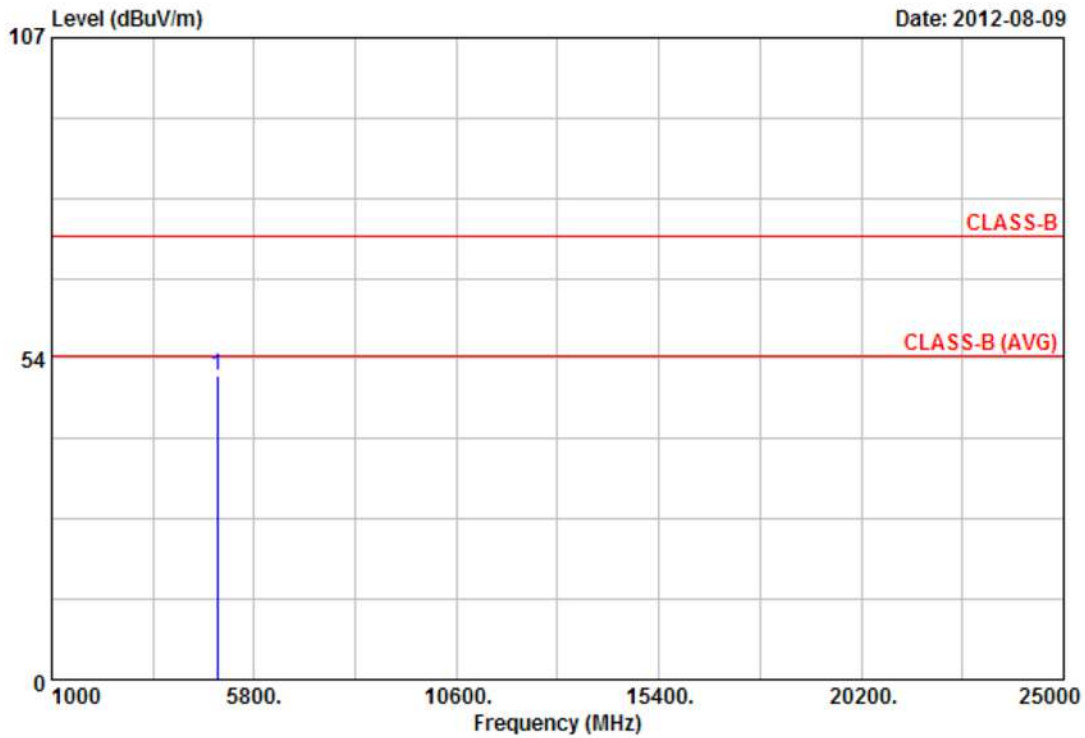

Item	Freq	Read Value	Factor	Result	Limit	Margin	Remark	Ant Pos	Tab Pos
	MHz	dBuV	dB/m	dBuV/m	dBuV/m	dB		cm	Deg
1	4924.00	45.60	4.93	50.53	74.00	-23.47	Peak	100	0

Notes:

1. Result = Read Value + Factor
2. Factor = Antenna Factor + Cable Loss - Amplifier
3. The resolution bandwidth of test receiver/spectrum analyzer is 120KHz and video bandwidth is 300kHz for Peak detection and Quasi-peak detection at frequency below 1GHz.
4. The resolution bandwidth of test receiver/spectrum analyzer is 1MHz and video bandwidth is 3MHz for Peak detection at frequency above 1GHz.
5. The resolution bandwidth of test receiver/spectrum analyzer is 1MHz and video bandwidth is 3MHz (detector sample mode) for Average detection at frequency above 1GHz.
6. The other emissions is too low to be measured. (The worst case noise floor measurements value is 47.93 dBuV at 16.10GHz)
7. The data is worse case.



Power	: From system	Pol/Phase	: VERTICAL
Test Mode 2	: 802.11n HT20, CH1	Temperature	: 23 °C
Memo	:	Humidity	: 65 %

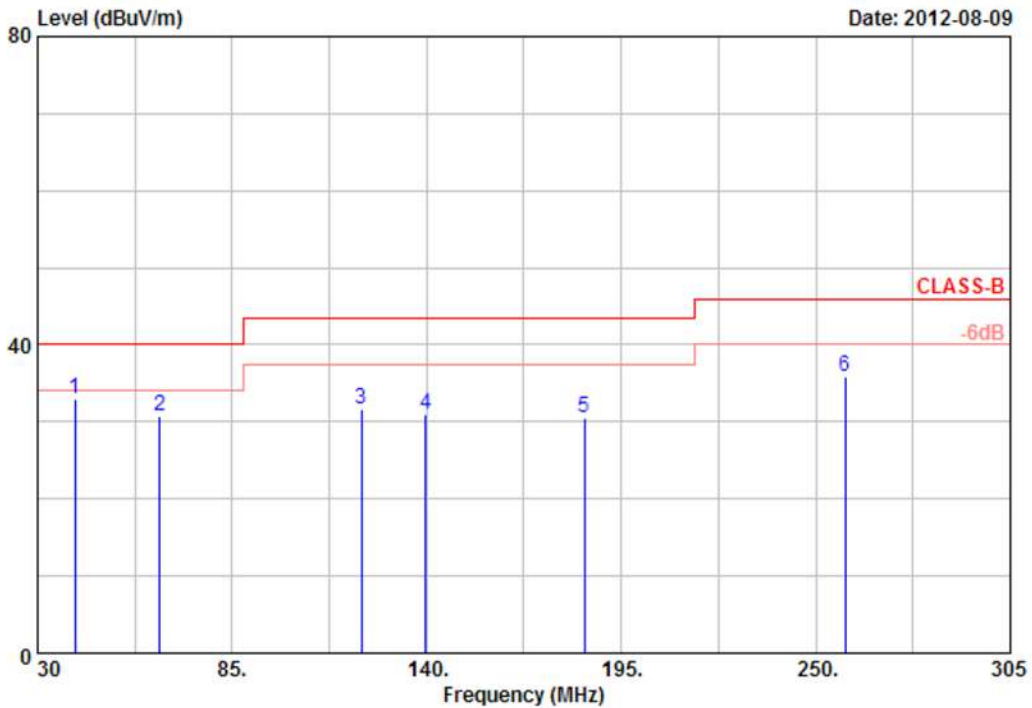

Item	Freq	Read Value	Factor	Result	Limit	Margin	Remark	Ant Pos	Tab Pos
	MHz	dBuV	dB/m	dBuV/m	dBuV/m	dB		cm	Deg
1	40.45	34.48	-1.52	32.96	40.00	-7.04	Peak	100	360
2	64.65	42.56	-11.81	30.75	40.00	-9.25	Peak	100	360
3	121.58	36.36	-4.74	31.62	43.50	-11.88	Peak	100	360
4	139.75	38.39	-7.49	30.90	43.50	-12.60	Peak	100	360
5	184.52	43.67	-13.19	30.48	43.50	-13.02	Peak	100	360
6	258.25	43.79	-7.95	35.84	46.00	-10.16	Peak	100	360

Notes:

1. Result = Read Value + Factor
2. Factor = Antenna Factor + Cable Loss - Amplifier
3. The resolution bandwidth of test receiver/spectrum analyzer is 120KHz and video bandwidth is 300kHz for Peak detection and Quasi-peak detection at frequency below 1GHz.
4. All emission below 1GHz at 802.11b/g/n mode are all the same, so the 802.11g/n mode chosen as representative in final test.
5. According to technical experiences, all spurious emission of 802.11g/n mode at channel 1,6,11 or 3,6,9(for HT40) are almost the same below 1GHz, so that the channel 1 or 3(for HT40) was chosen as representative in final test.
6. The data is worse case.



Power	: From system	Pol/Phase	: VERTICAL
Test Mode 2	: 802.11n HT20, CH1	Temperature	: 23 °C
Memo	:	Humidity	: 65 %

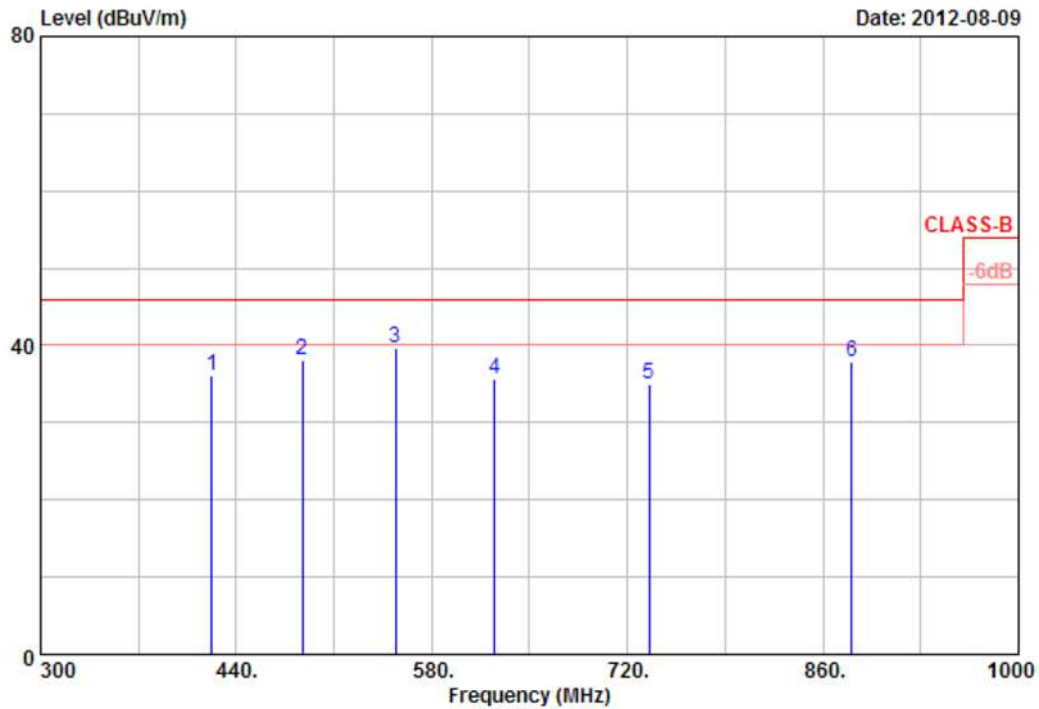

Item	Freq	Read Value	Factor	Result	Limit	Margin	Remark	Ant Pos	Tab Pos
	MHz	dBuV	dB/m	dBuV/m	dBuV/m	dB		cm	Deg
1	422.50	40.56	-4.55	36.01	46.00	-9.99	Peak	100	0
2	487.62	43.70	-5.59	38.11	46.00	-7.89	Peak	100	0
3	554.20	32.53	7.07	39.60	46.00	-6.40	Peak	100	0
4	624.80	35.11	0.64	35.75	46.00	-10.25	Peak	100	0
5	735.39	28.33	6.63	34.96	46.00	-11.04	Peak	100	0
6	880.30	27.91	10.07	37.98	46.00	-8.02	Peak	100	0

Notes:

1. Result = Read Value + Factor
2. Factor = Antenna Factor + Cable Loss - Amplifier
3. The resolution bandwidth of test receiver/spectrum analyzer is 120KHz and video bandwidth is 300kHz for Peak detection and Quasi-peak detection at frequency below 1GHz.
4. All emission below 1GHz at 802.11b/g/n mode are all the same, so the 802.11g/n mode chosen as representative in final test.
5. According to technical experiences, all spurious emission of 802.11g/n mode at channel 1,6,11 or 3,6,9(for HT40) are almost the same below 1GHz, so that the channel 1 or 3(for HT40) was chosen as representative in final test.
6. The data is worse case.



Power	: From system	Pol/Phase	: HORIZONTAL
Test Mode 2	: 802.11n HT20, CH1	Temperature	: 23 °C
Memo	:	Humidity	: 65 %

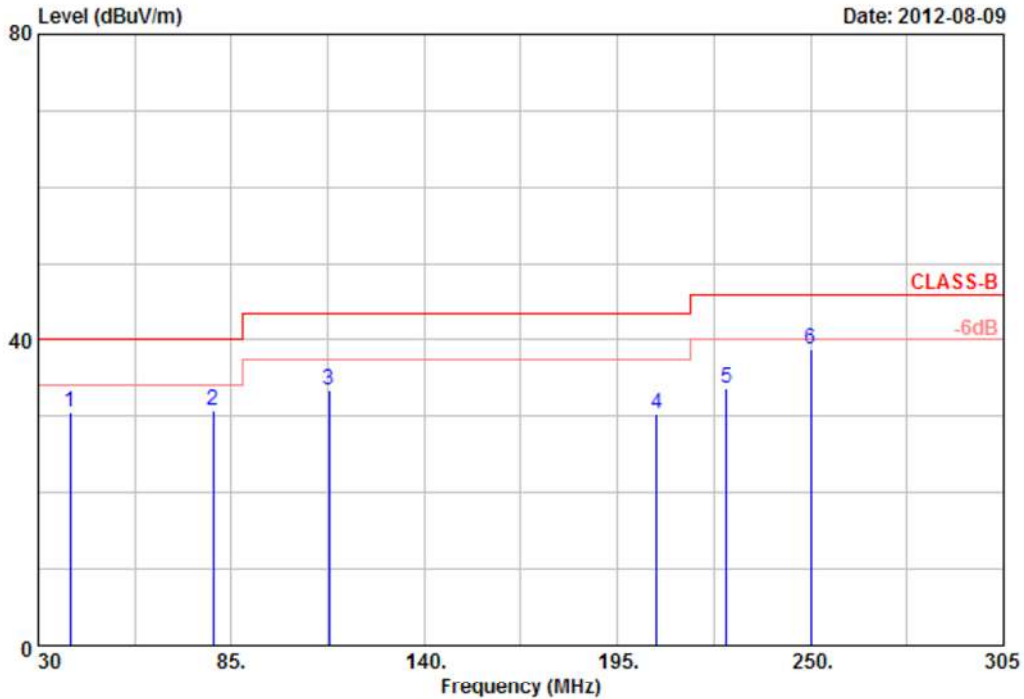

Item	Freq	Read Value	Factor	Result	Limit	Margin	Remark	Ant Pos	Tab Pos
	MHz	dBuV	dB/m	dBuV/m	dBuV/m	dB		cm	Deg
1	39.08	37.81	-7.27	30.54	40.00	-9.46	Peak	100	360
2	79.78	49.58	-18.73	30.85	40.00	-9.15	Peak	100	360
3	112.77	52.40	-18.99	33.41	43.50	-10.09	Peak	100	360
4	206.27	48.58	-18.34	30.24	43.50	-13.26	Peak	100	360
5	226.08	48.68	-14.98	33.70	46.00	-12.30	Peak	100	360
6	249.99	52.30	-13.52	38.78	46.00	-7.22	Peak	100	360

Notes:

1. Result = Read Value + Factor
2. Factor = Antenna Factor + Cable Loss - Amplifier
3. The resolution bandwidth of test receiver/spectrum analyzer is 120KHz and video bandwidth is 300kHz for Peak detection and Quasi-peak detection at frequency below 1GHz.
4. All emission below 1GHz at 802.11b/g/n mode are all the same, so the 802.11g/n mode chosen as representative in final test.
5. According to technical experiences, all spurious emission of 802.11g/n mode at channel 1, 6, 11 or 3, 6, 9 (for HT40) are almost the same below 1GHz, so that the channel 1 or 3 (for HT40) was chosen as representative in final test.
6. The data is worse case.



Power	: From system	Pol/Phase	: HORIZONTAL
Test Mode 2	: 802.11n HT20, CH1	Temperature	: 23 °C
Memo	:	Humidity	: 65 %

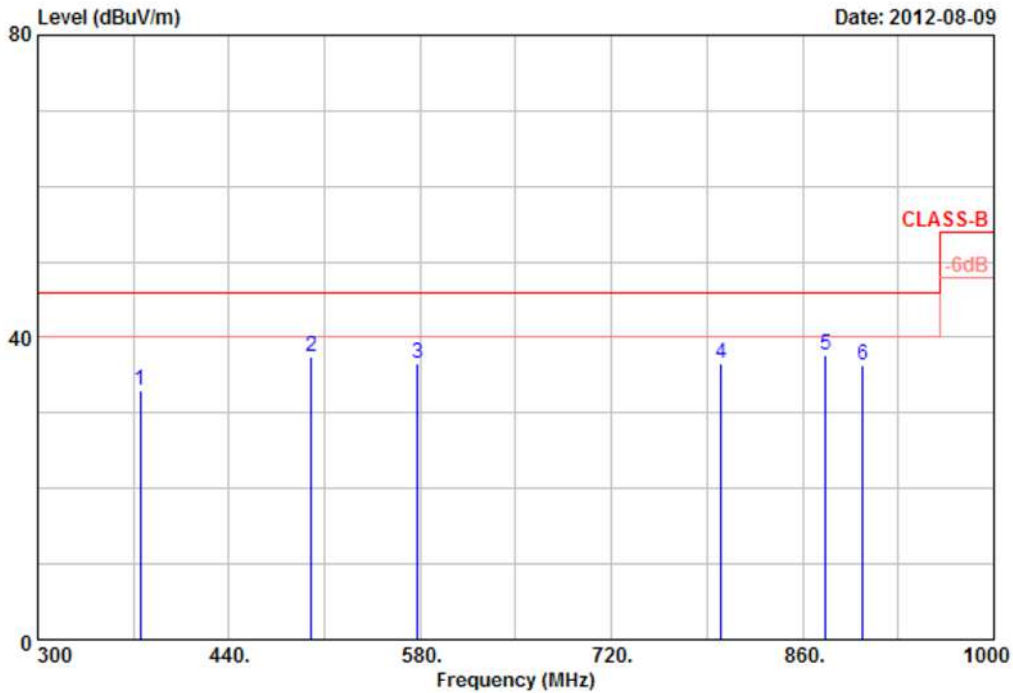

Item	Freq	Read Value	Factor	Result	Limit	Margin	Remark	Ant Pos	Tab Pos
	MHz	dBuV	dB/m	dBuV/m	dBuV/m	dB		cm	Deg
1	374.89	44.52	-11.64	32.88	46.00	-13.12	Peak	100	0
2	500.20	37.60	-0.11	37.49	46.00	-8.51	Peak	100	0
3	577.89	34.28	2.31	36.59	46.00	-9.41	Peak	100	0
4	800.50	30.36	6.14	36.50	46.00	-9.50	Peak	100	0
5	876.80	32.54	5.12	37.66	46.00	-8.34	Peak	100	0
6	904.10	31.23	5.10	36.33	46.00	-9.67	Peak	100	0

Notes:

1. Result = Read Value + Factor
2. Factor = Antenna Factor + Cable Loss - Amplifier
3. The resolution bandwidth of test receiver/spectrum analyzer is 120KHz and video bandwidth is 300KHz for Peak detection and Quasi-peak detection at frequency below 1GHz.
4. All emission below 1GHz at 802.11b/g/n mode are all the same, so the 802.11g/n mode chosen as representative in final test.
5. According to technical experiences, all spurious emission of 802.11g/n mode at channel 1,6,11 or 3,6,9(for HT40) are almost the same below 1GHz, so that the channel 1 or 3(for HT40) was chosen as representative in final test.
6. The data is worse case.



Power	: From system	Pol/Phase	: VERTICAL
Test Mode 2	: 802.11n HT20, CH1	Temperature	: 23 °C
Memo	:	Humidity	: 65 %

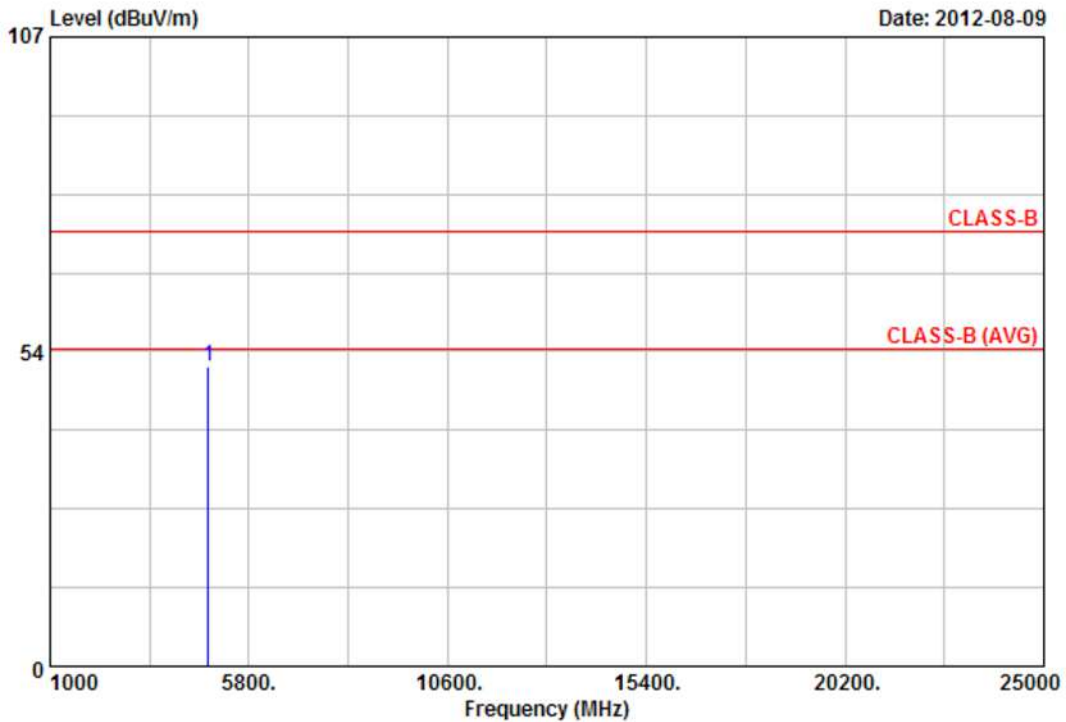

Item	Freq	Read Value	Factor	Result	Limit	Margin	Remark	Ant Pos	Tab Pos
	MHz	dBuV	dB/m	dBuV/m	dBuV/m	dB		cm	Deg
1	4824.00	45.70	5.37	51.07	74.00	-22.93	Peak	100	317

Notes:

1. Result = Read Value + Factor
2. Factor = Antenna Factor + Cable Loss - Amplifier
3. The resolution bandwidth of test receiver/spectrum analyzer is 120KHz and video bandwidth is 300kHz for Peak detection and Quasi-peak detection at frequency below 1GHz.
4. The resolution bandwidth of test receiver/spectrum analyzer is 1MHz and video bandwidth is 3MHz for Peak detection at frequency above 1GHz.
5. The resolution bandwidth of test receiver/spectrum analyzer is 1MHz and video bandwidth is 3MHz (detector sample mode) for Average detection at frequency above 1GHz.
6. The other emissions is too low to be measured. (The worst case noise floor measurements value is 47.93 dBuV at 16.10GHz)
7. The data is worse case.



Power	: From system	Pol/Phase	: HORIZONTAL
Test Mode 2	: 802.11n HT20, CH1	Temperature	: 23 °C
Memo	:	Humidity	: 65 %

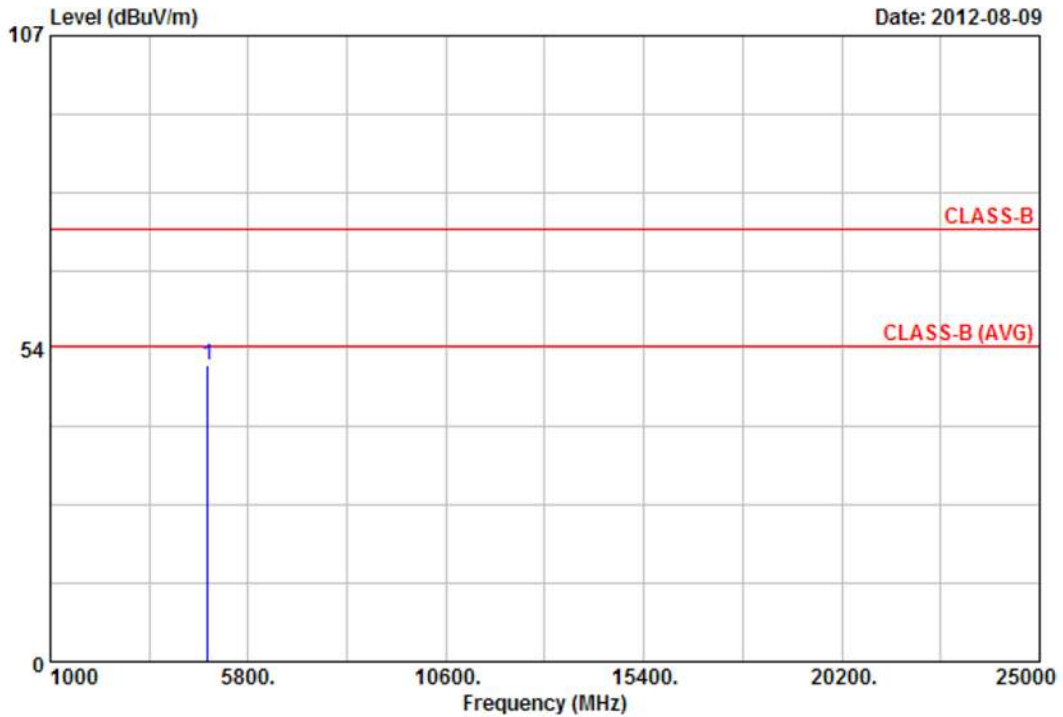

Item	Freq	Read Value	Factor	Result	Limit	Margin	Remark	Ant Pos	Tab Pos
	MHz	dBuV	dB/m	dBuV/m	dBuV/m	dB		cm	Deg
1	4824.00	46.98	3.71	50.69	74.00	-23.31	Peak	100	360

Notes:

1. Result = Read Value + Factor
2. Factor = Antenna Factor + Cable Loss - Amplifier
3. The resolution bandwidth of test receiver/spectrum analyzer is 120KHz and video bandwidth is 300kHz for Peak detection and Quasi-peak detection at frequency below 1GHz.
4. The resolution bandwidth of test receiver/spectrum analyzer is 1MHz and video bandwidth is 3MHz for Peak detection at frequency above 1GHz.
5. The resolution bandwidth of test receiver/spectrum analyzer is 1MHz and video bandwidth is 3MHz (detector sample mode) for Average detection at frequency above 1GHz.
6. The other emissions is too low to be measured. (The worst case noise floor measurements value is 47.93 dBuV at 16.10GHz)
7. The data is worse case.



Power	: From system	Pol/Phase	: VERTICAL
Test Mode 2	: 802.11n HT20, CH6	Temperature	: 23 °C
Memo	:	Humidity	: 65 %

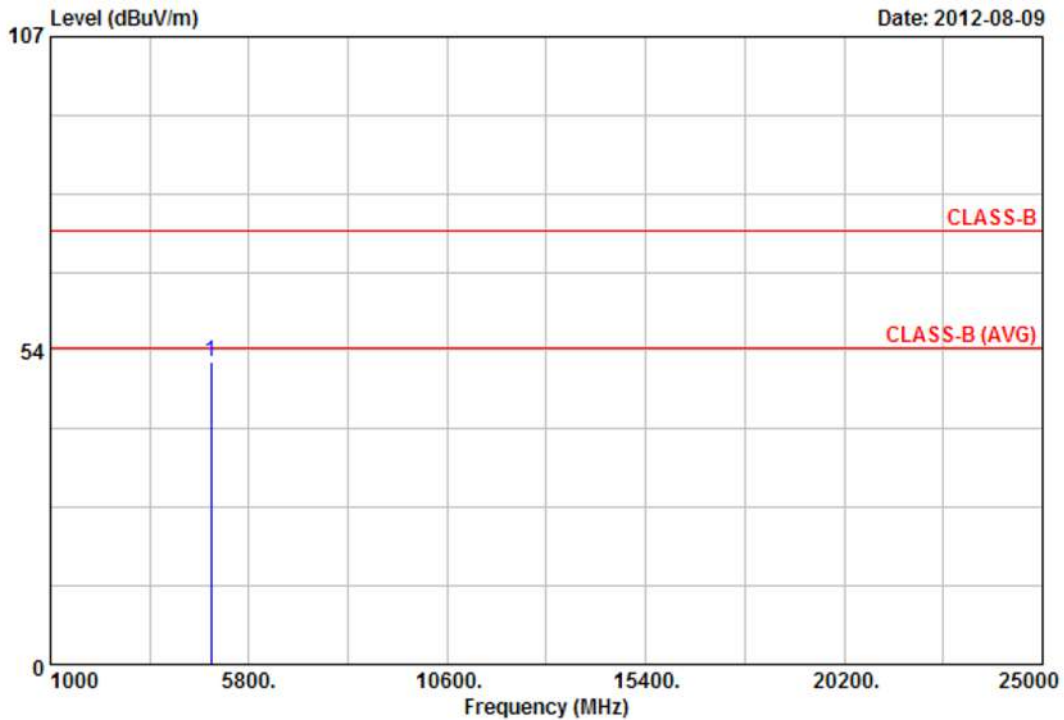

Item	Freq	Read Value	Factor	Result	Limit	Margin	Remark	Ant Pos	Tab Pos
	MHz	dBuV	dB/m	dBuV/m	dBuV/m	dB		cm	Deg
1	4874.00	45.15	6.36	51.51	74.00	-22.49	Peak	100	50

Notes:

1. Result = Read Value + Factor
2. Factor = Antenna Factor + Cable Loss - Amplifier
3. The resolution bandwidth of test receiver/spectrum analyzer is 120KHz and video bandwidth is 300kHz for Peak detection and Quasi-peak detection at frequency below 1GHz.
4. The resolution bandwidth of test receiver/spectrum analyzer is 1MHz and video bandwidth is 3MHz for Peak detection at frequency above 1GHz.
5. The resolution bandwidth of test receiver/spectrum analyzer is 1MHz and video bandwidth is 3MHz (detector sample mode) for Average detection at frequency above 1GHz.
6. The other emissions is too low to be measured. (The worst case noise floor measurements value is 47.93 dBuV at 16.10GHz)
7. The data is worse case.



Power	: From system	Pol/Phase	: HORIZONTAL
Test Mode 2	: 802.11n HT20, CH6	Temperature	: 23 °C
Memo	:	Humidity	: 65 %

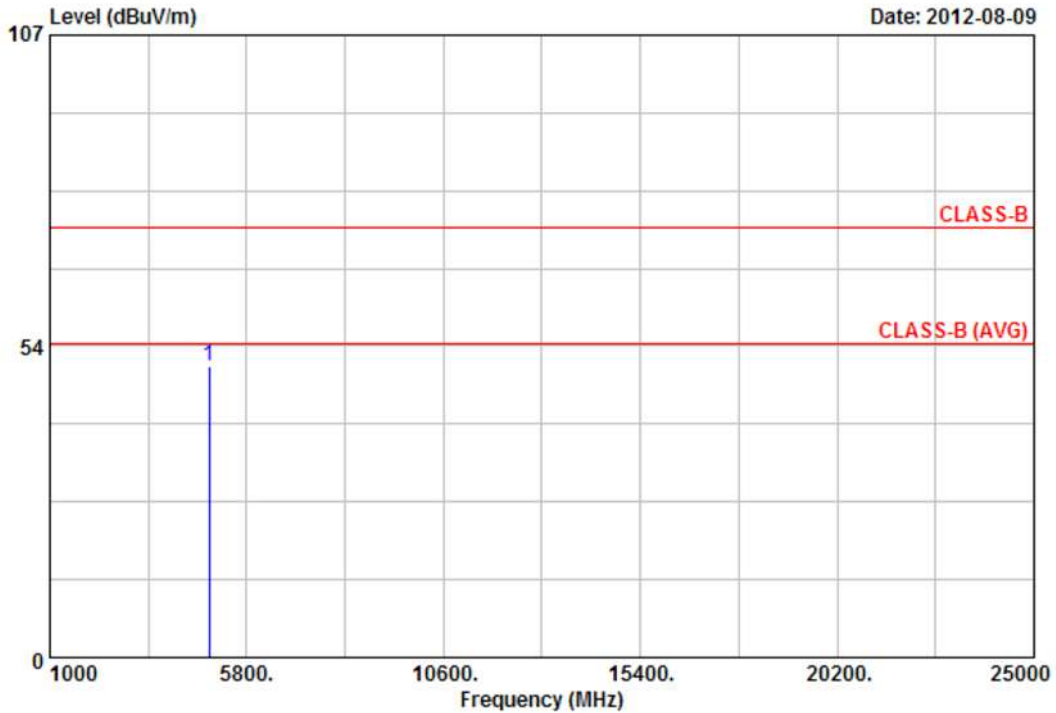

Item	Freq	Read Value	Factor	Result	Limit	Margin	Remark	Ant Pos	Tab Pos
	MHz	dBuV	dB/m	dBuV/m	dBuV/m	dB		cm	Deg
1	4874.00	45.58	4.50	50.08	74.00	-23.92	Peak	100	343

Notes:

1. Result = Read Value + Factor
2. Factor = Antenna Factor + Cable Loss - Amplifier
3. The resolution bandwidth of test receiver/spectrum analyzer is 120KHz and video bandwidth is 300kHz for Peak detection and Quasi-peak detection at frequency below 1GHz.
4. The resolution bandwidth of test receiver/spectrum analyzer is 1MHz and video bandwidth is 3MHz for Peak detection at frequency above 1GHz.
5. The resolution bandwidth of test receiver/spectrum analyzer is 1MHz and video bandwidth is 3MHz (detector sample mode) for Average detection at frequency above 1GHz.
6. The other emissions is too low to be measured. (The worst case noise floor measurements value is 47.93 dBuV at 16.10GHz)
7. The data is worse case.



Power	: From system	Pol/Phase	: VERTICAL
Test Mode 2	: 802.11n HT20, CH11	Temperature	: 23 °C
Memo	:	Humidity	: 65 %

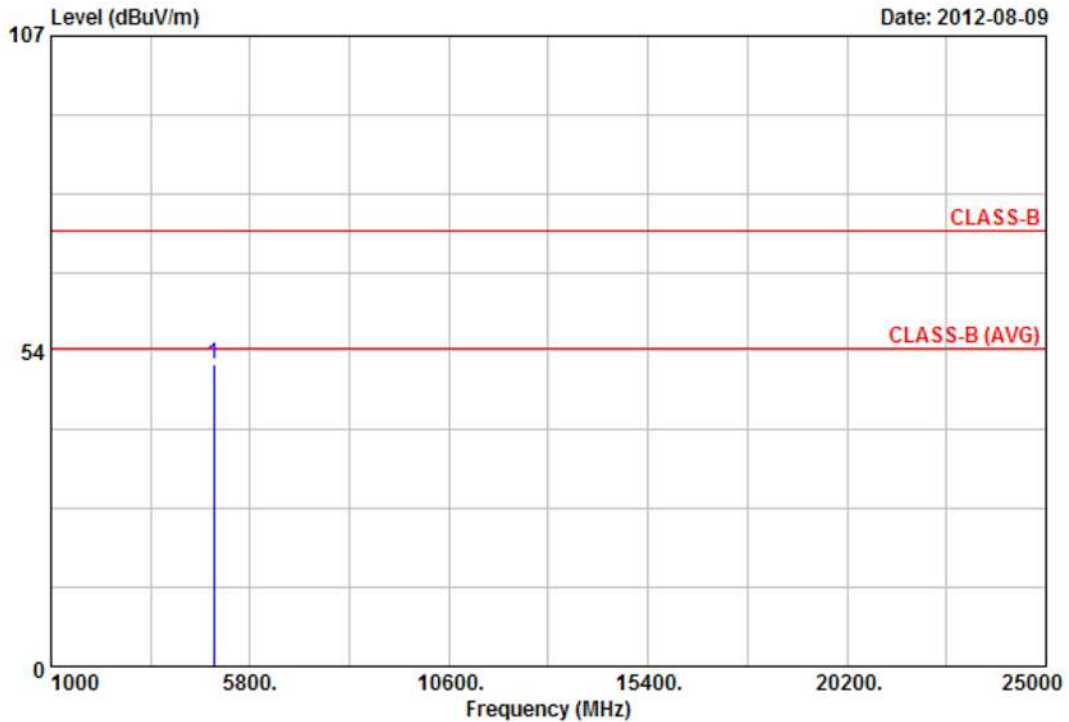

Item	Freq	Read Value	Factor	Result	Limit	Margin	Remark	Ant Pos	Tab Pos
	MHz	dBuV	dB/m	dBuV/m	dBuV/m	dB		cm	Deg
1	4924.50	44.19	6.94	51.13	74.00	-22.87	Peak	100	0

Notes:

1. Result = Read Value + Factor
2. Factor = Antenna Factor + Cable Loss - Amplifier
3. The resolution bandwidth of test receiver/spectrum analyzer is 120KHz and video bandwidth is 300kHz for Peak detection and Quasi-peak detection at frequency below 1GHz.
4. The resolution bandwidth of test receiver/spectrum analyzer is 1MHz and video bandwidth is 3MHz for Peak detection at frequency above 1GHz.
5. The resolution bandwidth of test receiver/spectrum analyzer is 1MHz and video bandwidth is 3MHz (detector sample mode) for Average detection at frequency above 1GHz.
6. The other emissions is too low to be measured. (The worst case noise floor measurements value is 47.93 dBuV at 16.10GHz)
7. The data is worse case.



Power	: From system	Pol/Phase	: HORIZONTAL
Test Mode 2	: 802.11n HT20, CH11	Temperature	: 23 °C
Memo	:	Humidity	: 65 %

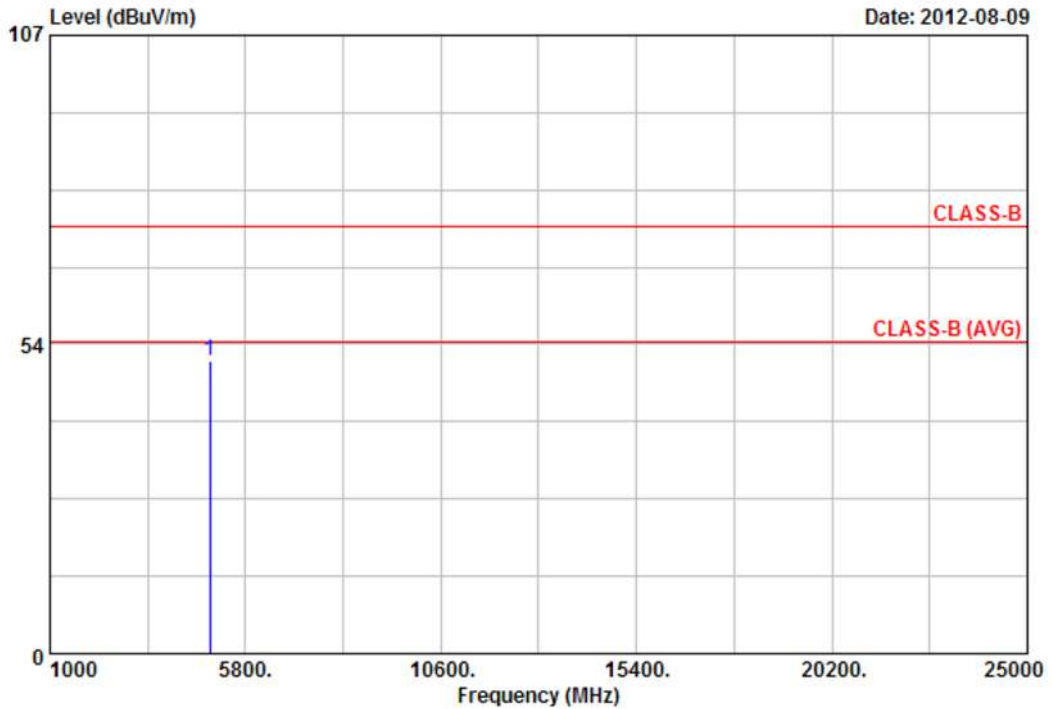

Item	Freq	Read Value	Factor	Result	Limit	Margin	Remark	Ant Pos	Tab Pos
	MHz	dBuV	dB/m	dBuV/m	dBuV/m	dB		cm	Deg
1	4924.00	45.78	4.93	50.71	74.00	-23.29	Peak	100	291

Notes:

1. Result = Read Value + Factor
2. Factor = Antenna Factor + Cable Loss - Amplifier
3. The resolution bandwidth of test receiver/spectrum analyzer is 120KHz and video bandwidth is 300kHz for Peak detection and Quasi-peak detection at frequency below 1GHz.
4. The resolution bandwidth of test receiver/spectrum analyzer is 1MHz and video bandwidth is 3MHz for Peak detection at frequency above 1GHz.
5. The resolution bandwidth of test receiver/spectrum analyzer is 1MHz and video bandwidth is 3MHz (detector sample mode) for Average detection at frequency above 1GHz.
6. The other emissions is too low to be measured. (The worst case noise floor measurements value is 47.93 dBuV at 16.10GHz)
7. The data is worse case.



Power	: From system	Pol/Phase	: VERTICAL
Test Mode 3	: 802.11n HT40, CH3	Temperature	: 23 °C
Memo	:	Humidity	: 65 %

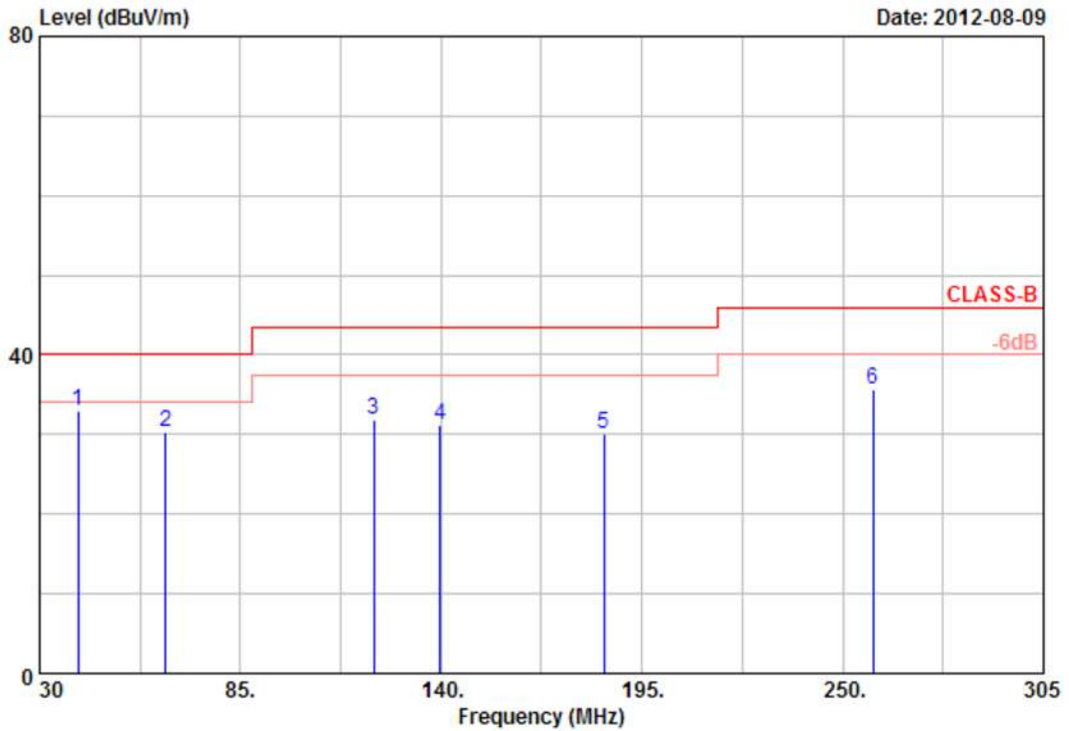

Item	Freq	Read Value	Factor	Result	Limit	Margin	Remark	Ant Pos	Tab Pos
	MHz	dBuV	dB/m	dBuV/m	dBuV/m	dB		cm	Deg
1	40.45	34.40	-1.52	32.88	40.00	-7.12	Peak	100	360
2	64.65	42.16	-11.81	30.35	40.00	-9.65	Peak	100	360
3	121.58	36.57	-4.74	31.83	43.50	-11.67	Peak	100	360
4	139.75	38.66	-7.49	31.17	43.50	-12.33	Peak	100	360
5	184.52	43.37	-13.19	30.18	43.50	-13.32	Peak	100	360
6	258.25	43.59	-7.95	35.64	46.00	-10.36	Peak	100	360

Notes:

1. Result = Read Value + Factor
2. Factor = Antenna Factor + Cable Loss - Amplifier
3. The resolution bandwidth of test receiver/spectrum analyzer is 120KHz and video bandwidth is 300kHz for Peak detection and Quasi-peak detection at frequency below 1GHz.
4. All emission below 1GHz at 802.11b/g/n mode are all the same, so the 802.11g/n mode chosen as representative in final test.
5. According to technical experiences, all spurious emission of 802.11g/n mode at channel 1, 6, 11 or 3, 6, 9 (for HT40) are almost the same below 1GHz, so that the channel 1 or 3 (for HT40) was chosen as representative in final test.
6. The data is worse case.



Power	: From system	Pol/Phase	: VERTICAL
Test Mode 3	: 802.11n HT40, CH3	Temperature	: 23 °C
Memo	:	Humidity	: 65 %

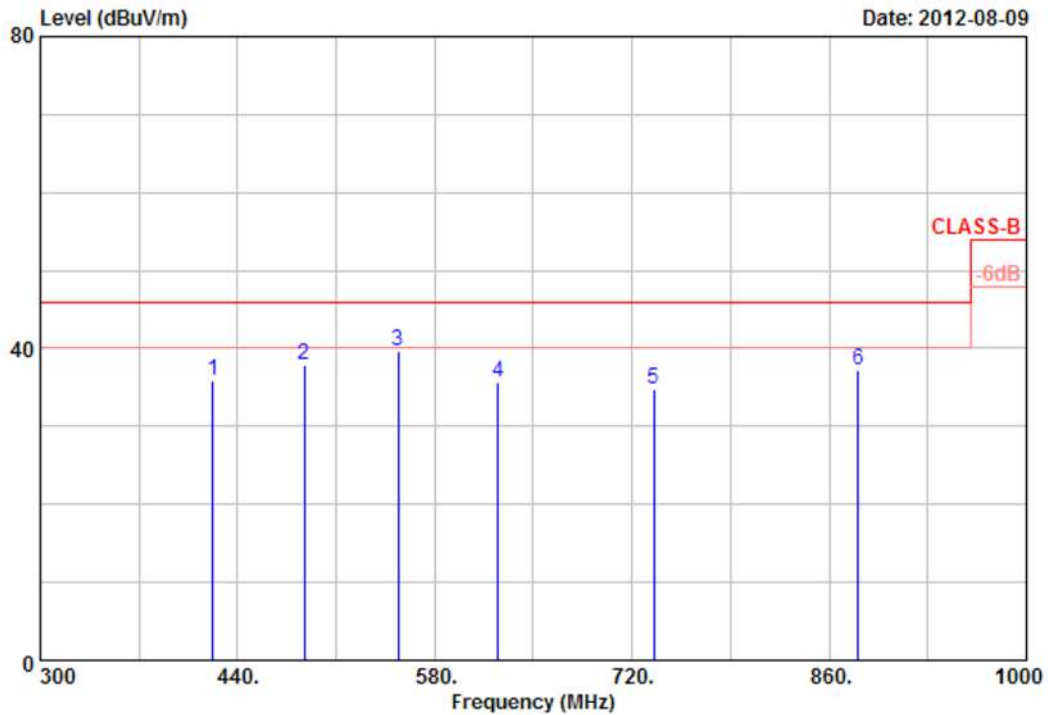

Item	Freq	Read Value	Factor	Result	Limit	Margin	Remark	Ant Pos	Tab Pos
	MHz	dBuV	dB/m	dBuV/m	dBuV/m	dB		cm	Deg
1	422.50	40.45	-4.55	35.90	46.00	-10.10	Peak	100	0
2	487.62	43.37	-5.59	37.78	46.00	-8.22	Peak	100	0
3	554.20	32.63	7.07	39.70	46.00	-6.30	Peak	100	0
4	624.80	35.11	0.64	35.75	46.00	-10.25	Peak	100	0
5	735.39	28.16	6.63	34.79	46.00	-11.21	Peak	100	0
6	880.30	27.21	10.07	37.28	46.00	-8.72	Peak	100	0

Notes:

1. Result = Read Value + Factor
2. Factor = Antenna Factor + Cable Loss - Amplifier
3. The resolution bandwidth of test receiver/spectrum analyzer is 120KHz and video bandwidth is 300kHz for Peak detection and Quasi-peak detection at frequency below 1GHz.
4. All emission below 1GHz at 802.11b/g/n mode are all the same, so the 802.11g/n mode chosen as representative in final test.
5. According to technical experiences, all spurious emission of 802.11g/n mode at channel 1,6,11 or 3,6,9(for HT40) are almost the same below 1GHz, so that the channel 1 or 3(for HT40) was chosen as representative in final test.
6. The data is worse case.



Power	: From system	Pol/Phase	: HORIZONTAL
Test Mode 3	: 802.11n HT40, CH3	Temperature	: 23 °C
Memo	:	Humidity	: 65 %

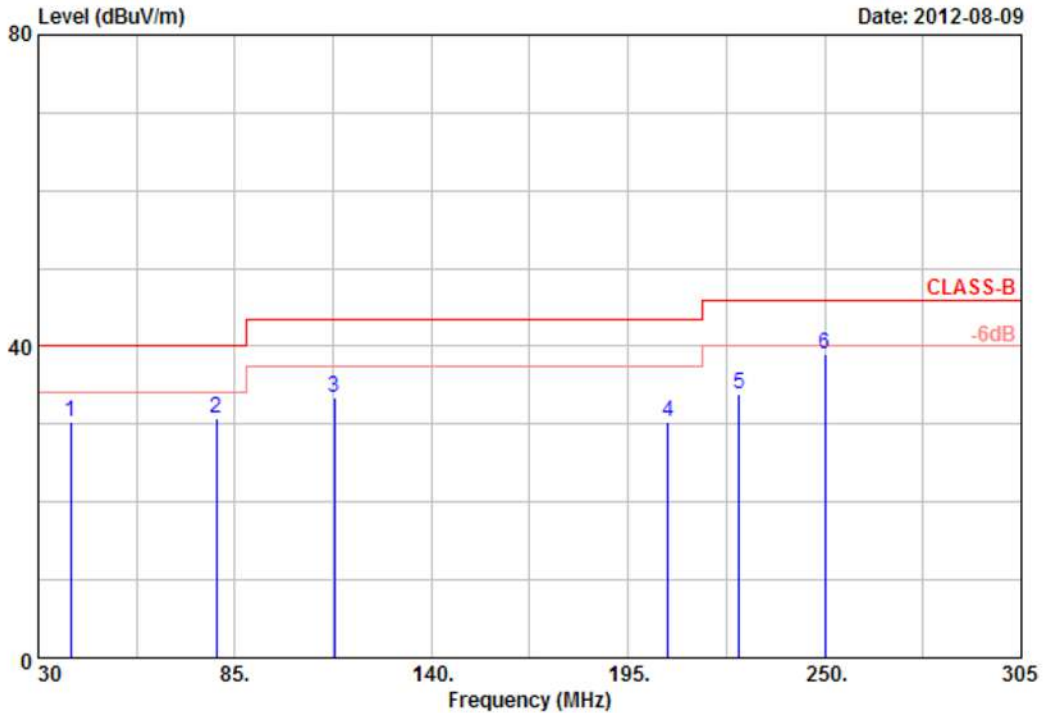

Item	Freq	Read Value	Factor	Result	Limit	Margin	Remark	Ant Pos	Tab Pos
	MHz	dBuV	dB/m	dBuV/m	dBuV/m	dB		cm	Deg
1	39.08	37.61	-7.27	30.34	40.00	-9.66	Peak	100	360
2	79.78	49.58	-18.73	30.85	40.00	-9.15	Peak	100	360
3	112.77	52.50	-18.99	33.51	43.50	-9.99	Peak	100	360
4	206.27	48.58	-18.34	30.24	43.50	-13.26	Peak	100	360
5	226.08	48.82	-14.98	33.84	46.00	-12.16	Peak	100	360
6	249.99	52.60	-13.52	39.08	46.00	-6.92	Peak	100	360

Notes:

1. Result = Read Value + Factor
2. Factor = Antenna Factor + Cable Loss - Amplifier
3. The resolution bandwidth of test receiver/spectrum analyzer is 120KHz and video bandwidth is 300kHz for Peak detection and Quasi-peak detection at frequency below 1GHz.
4. All emission below 1GHz at 802.11b/g/n mode are all the same, so the 802.11g/n mode chosen as representative in final test.
5. According to technical experiences, all spurious emission of 802.11g/n mode at channel 1, 6, 11 or 3, 6, 9 (for HT40) are almost the same below 1GHz, so that the channel 1 or 3 (for HT40) was chosen as representative in final test.
6. The data is worse case.



Power	: From system	Pol/Phase	: HORIZONTAL
Test Mode 3	: 802.11n HT40, CH3	Temperature	: 23 °C
Memo	:	Humidity	: 65 %

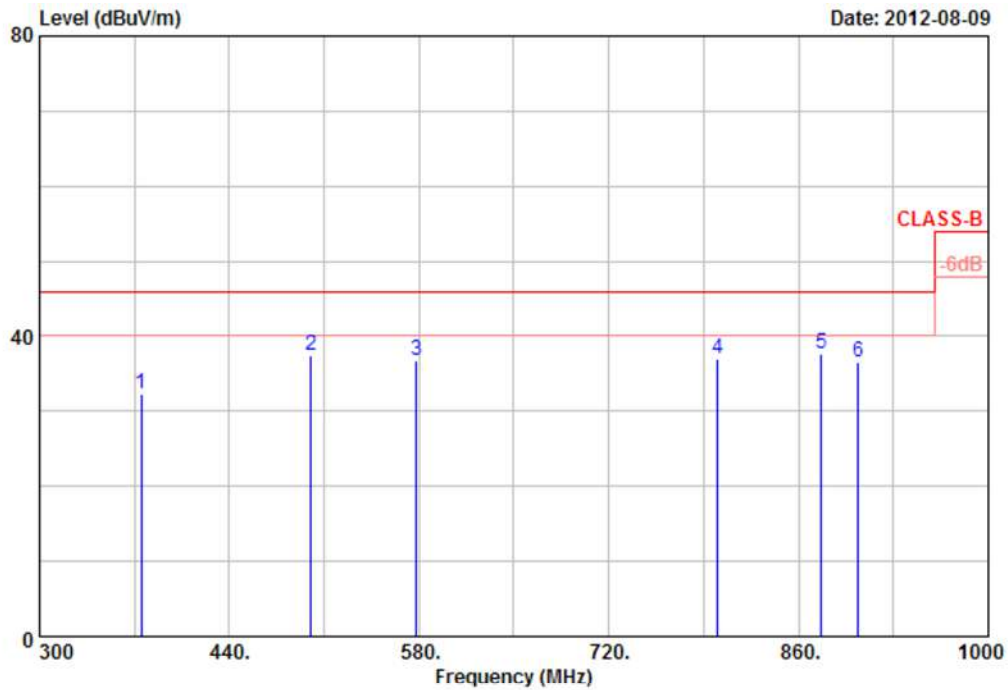

Item	Freq	Read Value	Factor	Result	Limit	Margin	Remark	Ant Pos	Tab Pos
	MHz	dBuV	dB/m	dBuV/m	dBuV/m	dB		cm	Deg
1	374.89	44.02	-11.64	32.38	46.00	-13.62	Peak	100	0
2	500.20	37.50	-0.11	37.39	46.00	-8.61	Peak	100	0
3	577.89	34.53	2.31	36.84	46.00	-9.16	Peak	100	0
4	800.50	30.80	6.14	36.94	46.00	-9.06	Peak	100	0
5	876.80	32.65	5.12	37.77	46.00	-8.23	Peak	100	0
6	904.10	31.42	5.10	36.52	46.00	-9.48	Peak	100	0

Notes:

1. Result = Read Value + Factor
2. Factor = Antenna Factor + Cable Loss - Amplifier
3. The resolution bandwidth of test receiver/spectrum analyzer is 120KHz and video bandwidth is 300kHz for Peak detection and Quasi-peak detection at frequency below 1GHz.
4. All emission below 1GHz at 802.11b/g/n mode are all the same, so the 802.11g/n mode chosen as representative in final test.
5. According to technical experiences, all spurious emission of 802.11g/n mode at channel 1,6,11 or 3,6,9(for HT40) are almost the same below 1GHz, so that the channel 1 or 3(for HT40) was chosen as representative in final test.
6. The data is worse case.



Power	: From system	Pol/Phase	: VERTICAL
Test Mode 3	: 802.11n HT40, CH3	Temperature	: 23 °C
Memo	:	Humidity	: 65 %

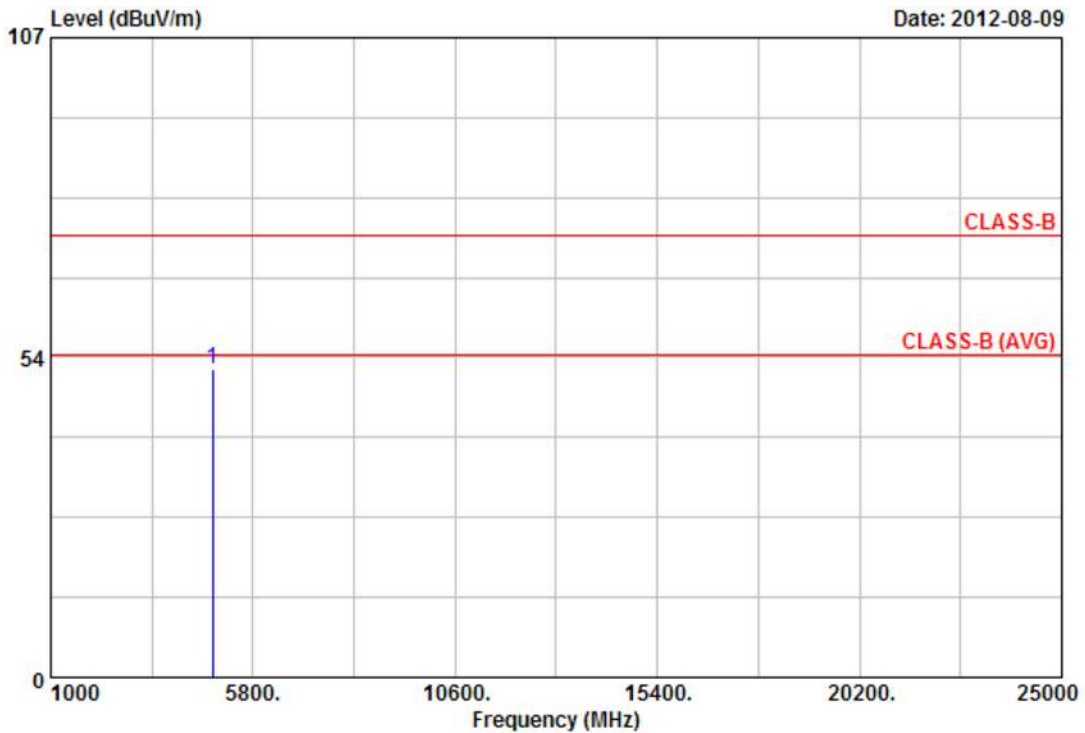

Item	Freq	Read Value	Factor	Result	Limit	Margin	Remark	Ant Pos	Tab Pos
	MHz	dBuV	dB/m	dBuV/m	dBuV/m	dB		cm	Deg
1	4844.00	45.82	5.77	51.59	74.00	-22.41	Peak	100	0

Notes:

1. Result = Read Value + Factor
2. Factor = Antenna Factor + Cable Loss - Amplifier
3. The resolution bandwidth of test receiver/spectrum analyzer is 120KHz and video bandwidth is 300kHz for Peak detection and Quasi-peak detection at frequency below 1GHz.
4. The resolution bandwidth of test receiver/spectrum analyzer is 1MHz and video bandwidth is 3MHz for Peak detection at frequency above 1GHz.
5. The resolution bandwidth of test receiver/spectrum analyzer is 1MHz and video bandwidth is 3MHz (detector sample mode) for Average detection at frequency above 1GHz.
6. The other emissions is too low to be measured. (The worst case noise floor measurements value is 47.93 dBuV at 16.10GHz)
7. The data is worse case.



Power	: From system	Pol/Phase	: HORIZONTAL
Test Mode 3	: 802.11n HT40, CH3	Temperature	: 23 °C
Memo	:	Humidity	: 65 %

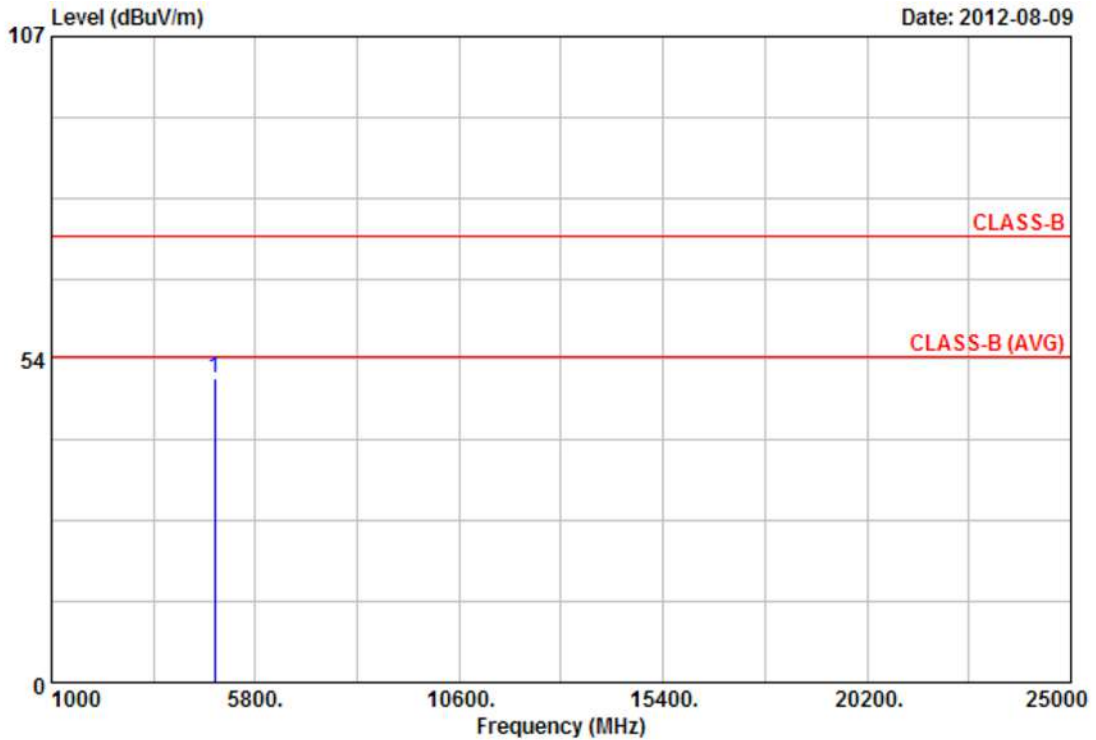

Item	Freq	Read Value	Factor	Result	Limit	Margin	Remark	Ant Pos	Tab Pos
	MHz	dBuV	dB/m	dBuV/m	dBuV/m	dB		cm	Deg
1	4844.00	46.44	4.03	50.47	74.00	-23.53	Peak	100	360

Notes:

1. Result = Read Value + Factor
2. Factor = Antenna Factor + Cable Loss - Amplifier
3. The resolution bandwidth of test receiver/spectrum analyzer is 120KHz and video bandwidth is 300kHz for Peak detection and Quasi-peak detection at frequency below 1GHz.
4. The resolution bandwidth of test receiver/spectrum analyzer is 1MHz and video bandwidth is 3MHz for Peak detection at frequency above 1GHz.
5. The resolution bandwidth of test receiver/spectrum analyzer is 1MHz and video bandwidth is 3MHz (detector sample mode) for Average detection at frequency above 1GHz.
6. The other emissions is too low to be measured. (The worst case noise floor measurements value is 47.93 dBuV at 16.10GHz)
7. The data is worse case.



Power	: From system	Pol/Phase	: VERTICAL
Test Mode 3	: 802.11n HT40, CH6	Temperature	: 23 °C
Memo	:	Humidity	: 65 %

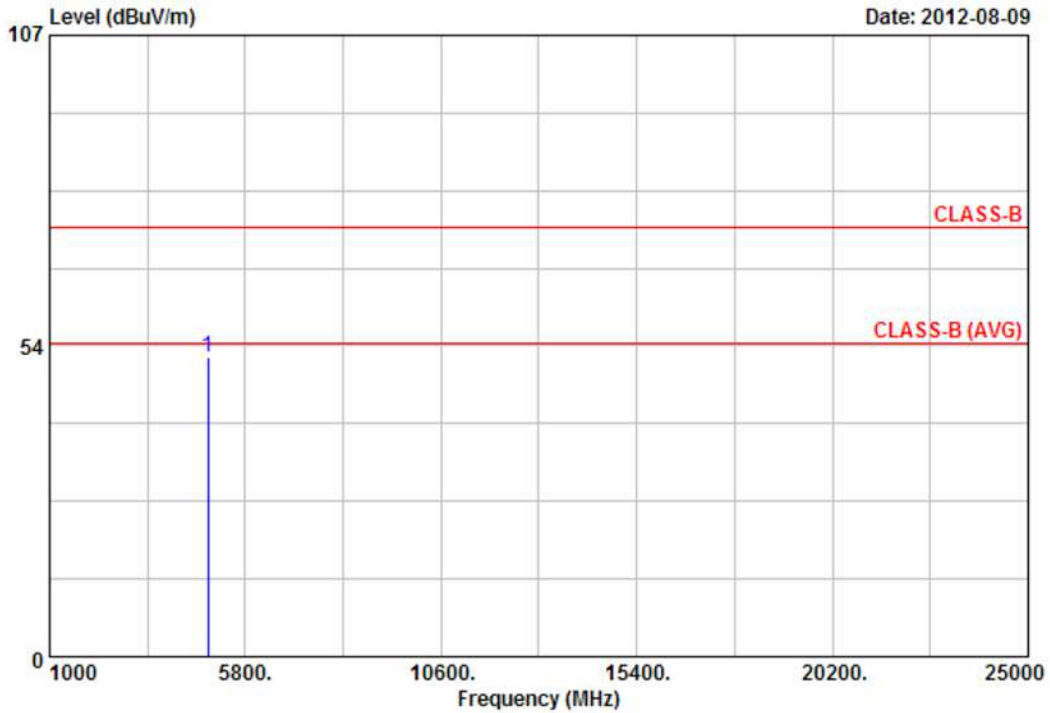

Item	Freq	Read Value	Factor	Result	Limit	Margin	Remark	Ant Pos	Tab Pos
	MHz	dBuV	dB/m	dBuV/m	dBuV/m	dB		cm	Deg
1	4874.00	45.18	6.36	51.54	74.00	-22.46	Peak	100	0

Notes:

1. Result = Read Value + Factor
2. Factor = Antenna Factor + Cable Loss - Amplifier
3. The resolution bandwidth of test receiver/spectrum analyzer is 120KHz and video bandwidth is 300kHz for Peak detection and Quasi-peak detection at frequency below 1GHz.
4. The resolution bandwidth of test receiver/spectrum analyzer is 1MHz and video bandwidth is 3MHz for Peak detection at frequency above 1GHz.
5. The resolution bandwidth of test receiver/spectrum analyzer is 1MHz and video bandwidth is 3MHz (detector sample mode) for Average detection at frequency above 1GHz.
6. The other emissions is too low to be measured. (The worst case noise floor measurements value is 47.93 dBuV at 16.10GHz)
7. The data is worse case.



Power	: From system	Pol/Phase	: HORIZONTAL
Test Mode 3	: 802.11n HT40, CH6	Temperature	: 23 °C
Memo	:	Humidity	: 65 %

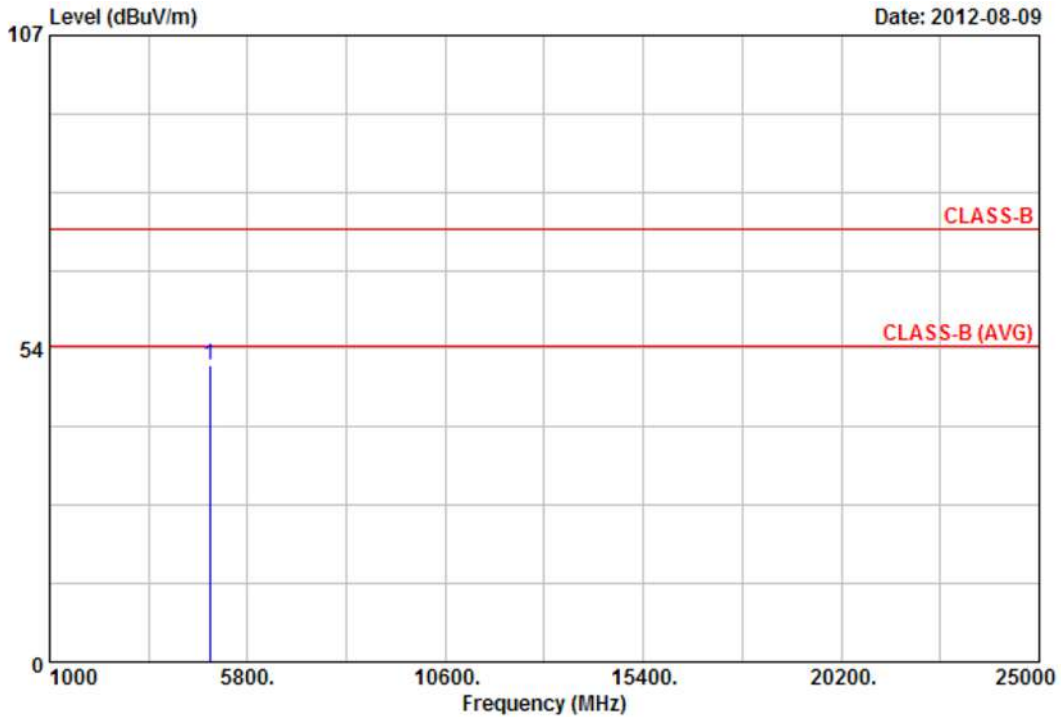

Item	Freq	Read Value	Factor	Result	Limit	Margin	Remark	Ant Pos	Tab Pos
	MHz	dBuV	dB/m	dBuV/m	dBuV/m	dB		cm	Deg
1	4874.00	46.20	4.50	50.70	74.00	-23.30	Peak	100	360

Notes:

1. Result = Read Value + Factor
2. Factor = Antenna Factor + Cable Loss - Amplifier
3. The resolution bandwidth of test receiver/spectrum analyzer is 120KHz and video bandwidth is 300kHz for Peak detection and Quasi-peak detection at frequency below 1GHz.
4. The resolution bandwidth of test receiver/spectrum analyzer is 1MHz and video bandwidth is 3MHz for Peak detection at frequency above 1GHz.
5. The resolution bandwidth of test receiver/spectrum analyzer is 1MHz and video bandwidth is 3MHz (detector sample mode) for Average detection at frequency above 1GHz.
6. The other emissions is too low to be measured. (The worst case noise floor measurements value is 47.93 dBuV at 16.10GHz)
7. The data is worse case.



Power	: From system	Pol/Phase	: VERTICAL
Test Mode 3	: 802.11n HT40, CH9	Temperature	: 23 °C
Memo	:	Humidity	: 65 %

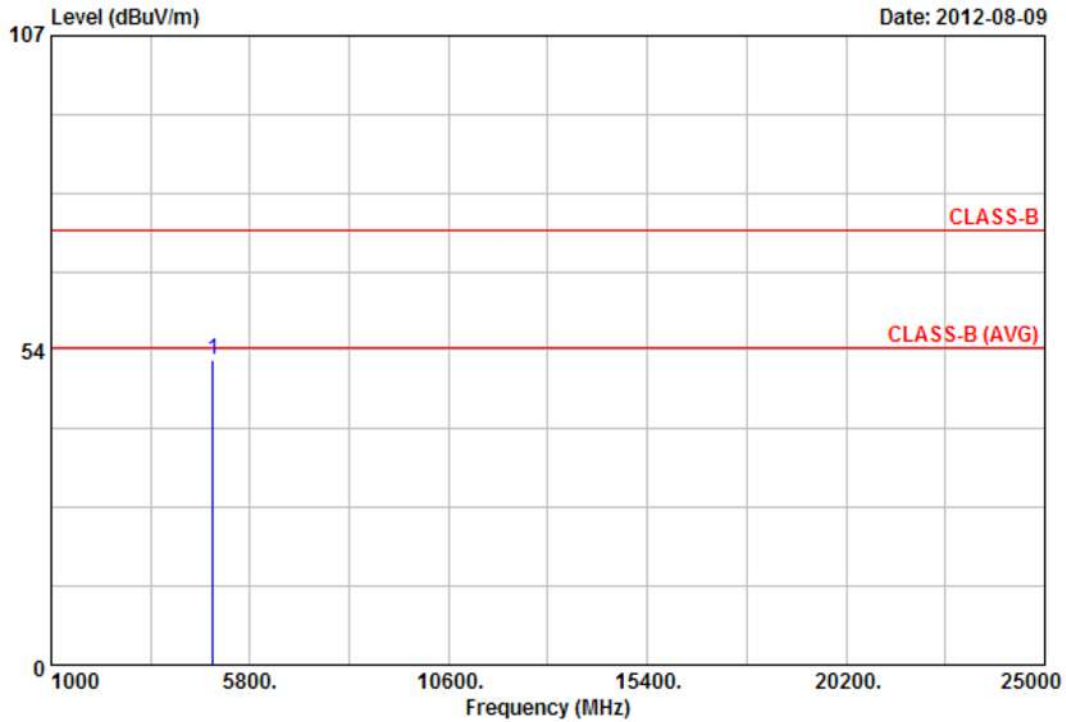

Item	Freq	Read Value	Factor	Result	Limit	Margin	Remark	Ant Pos	Tab Pos
	MHz	dBuV	dB/m	dBuV/m	dBuV/m	dB		cm	Deg
1	4898.75	45.09	6.86	51.95	74.00	-22.05	Peak	100	0

Notes:

1. Result = Read Value + Factor
2. Factor = Antenna Factor + Cable Loss - Amplifier
3. The resolution bandwidth of test receiver/spectrum analyzer is 120KHz and video bandwidth is 300kHz for Peak detection and Quasi-peak detection at frequency below 1GHz.
4. The resolution bandwidth of test receiver/spectrum analyzer is 1MHz and video bandwidth is 3MHz for Peak detection at frequency above 1GHz.
5. The resolution bandwidth of test receiver/spectrum analyzer is 1MHz and video bandwidth is 3MHz (detector sample mode) for Average detection at frequency above 1GHz.
6. The other emissions is too low to be measured. (The worst case noise floor measurements value is 47.93 dBuV at 16.10GHz)
7. The data is worse case.



Power	: From system	Pol/Phase	: HORIZONTAL
Test Mode 3	: 802.11n HT40, CH9	Temperature	: 23 °C
Memo	:	Humidity	: 65 %

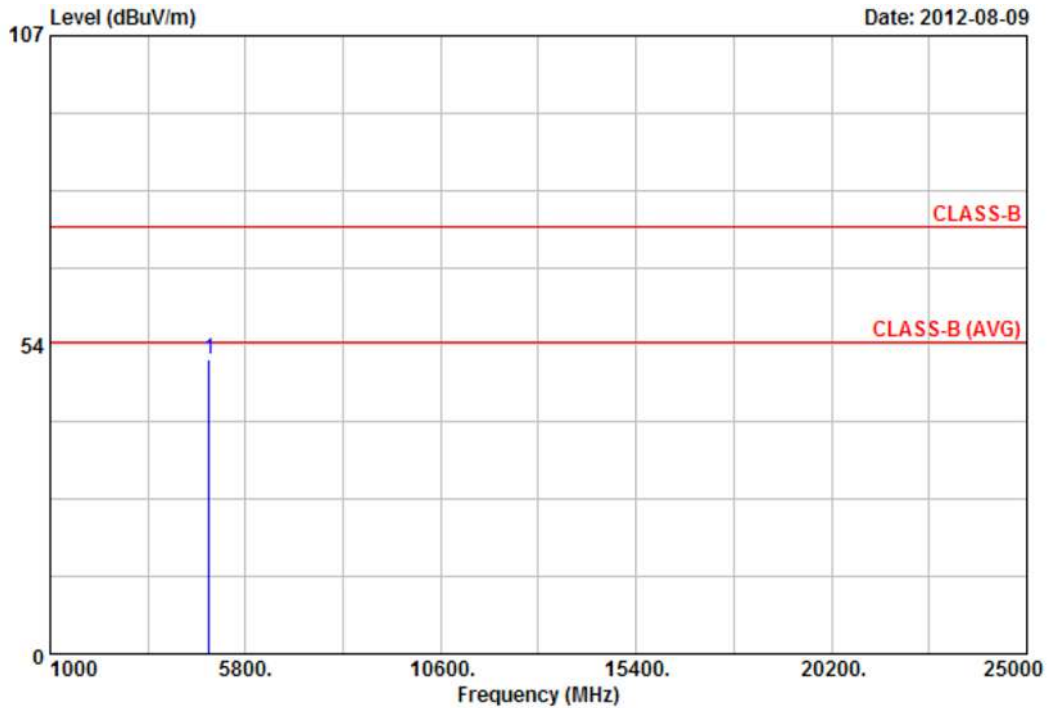

Item	Freq	Read Value	Factor	Result	Limit	Margin	Remark	Ant Pos	Tab Pos
	MHz	dBuV	dB/m	dBuV/m	dBuV/m	dB		cm	Deg
1	4904.00	45.98	4.92	50.90	74.00	-23.10	Peak	100	360

Notes:

1. Result = Read Value + Factor
2. Factor = Antenna Factor + Cable Loss - Amplifier
3. The resolution bandwidth of test receiver/spectrum analyzer is 120KHz and video bandwidth is 300kHz for Peak detection and Quasi-peak detection at frequency below 1GHz.
4. The resolution bandwidth of test receiver/spectrum analyzer is 1MHz and video bandwidth is 3MHz for Peak detection at frequency above 1GHz.
5. The resolution bandwidth of test receiver/spectrum analyzer is 1MHz and video bandwidth is 3MHz (detector sample mode) for Average detection at frequency above 1GHz.
6. The other emissions is too low to be measured. (The worst case noise floor measurements value is 47.93 dBuV at 16.10GHz)
7. The data is worse case.



6. 6dB Bandwidth Measurement Data

6.1 Test Limit

The minimum of 6dB Bandwidth Measurement is 0.5 MHz.

6.2 Test Procedures

- The transmitter output was connected to the spectrum analyzer.
- Set RBW of spectrum analyzer to 1~5% of the emission bandwidth and VBW \geq 3x RBW.
- The 6 dB bandwidth is defined as the total spectrum the power of which is higher than peak power minus 6 dB.
- The 6dB Bandwidth was measured and recorded.

6.3 Test Setup Layout

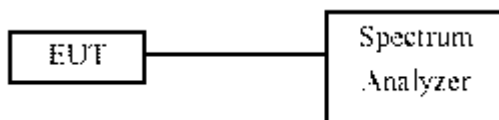

6.4 Measurement Equipment

Instrument/Ancillary	Manufacturer	Model No.	Serial No.	Calibration Date	Valid Date
Spectrum Analyzer	R&S	FSP40	100219	2011/11/24	2012/11/23

6.5 Test Result and Data

Test Date: Aug. 07, 2012

Temperature: 25°C

Atmospheric pressure: 1020 hPa

Humidity: 65%

Modulation Standard	Channel	Frequency (MHz)	6dB Bandwidth (MHz)	
			ANT R	ANT L
802.11b (11Mbps)	01	2412	12.1	11.7
	06	2437	11.7	11.8
	11	2462	11.8	11.6
802.11g (54Mbps)	01	2412	16.6	16.6
	06	2437	16.6	16.6
	11	2462	16.8	16.8
802.11n HT20 (130Mbps)	01	2412	17.6	17.7
	06	2437	17.6	17.9
	11	2462	17.5	17.5
802.11n HT40 (270Mbps)	03	2422	35.8	36.0
	06	2437	36.2	36.2
	09	2452	36.4	36.2



Modulation Standard: 802.11b (11Mbps), ANT R
Channel: 01

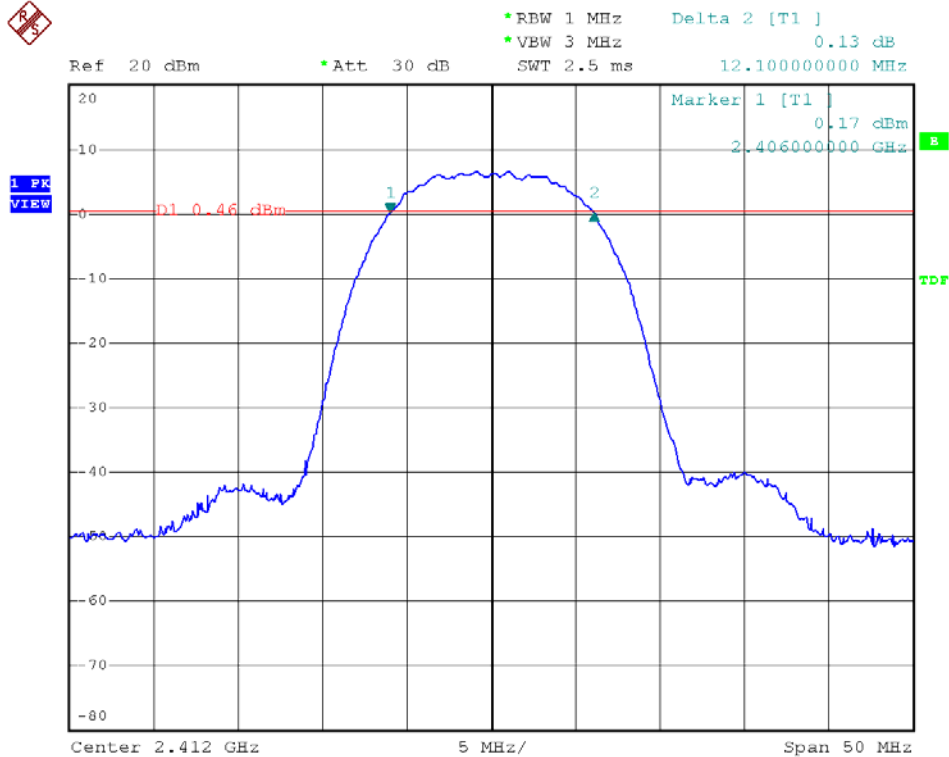

Modulation Standard: 802.11b (11Mbps), ANT R
Channel: 06

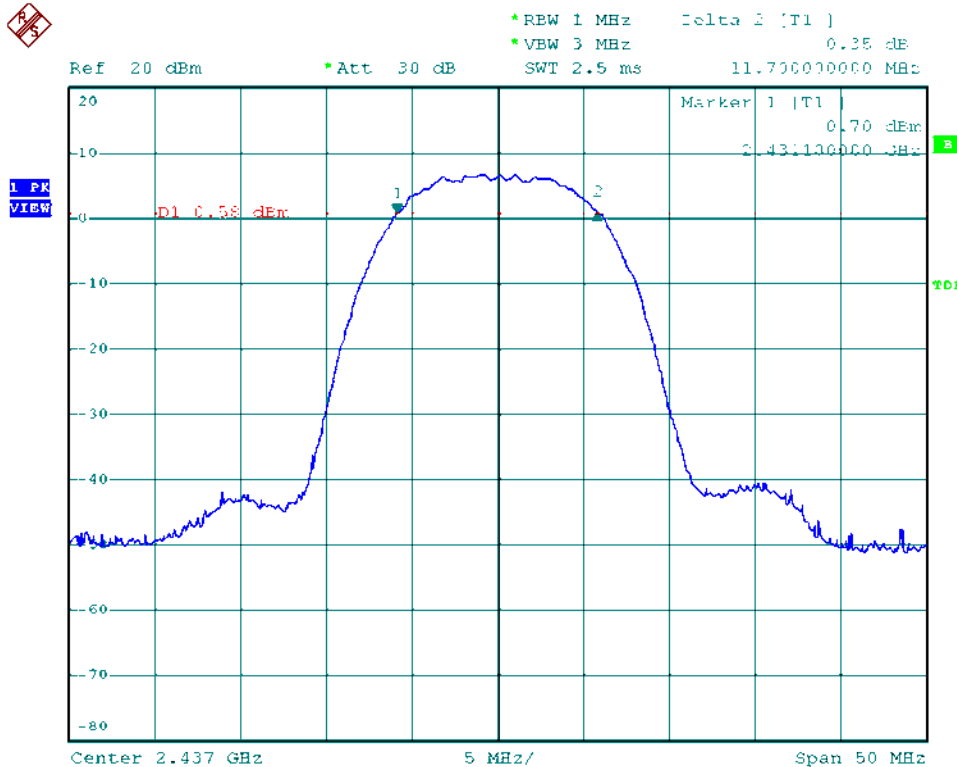



Modulation Standard: 802.11b (11Mbps), ANT R
Channel: 11

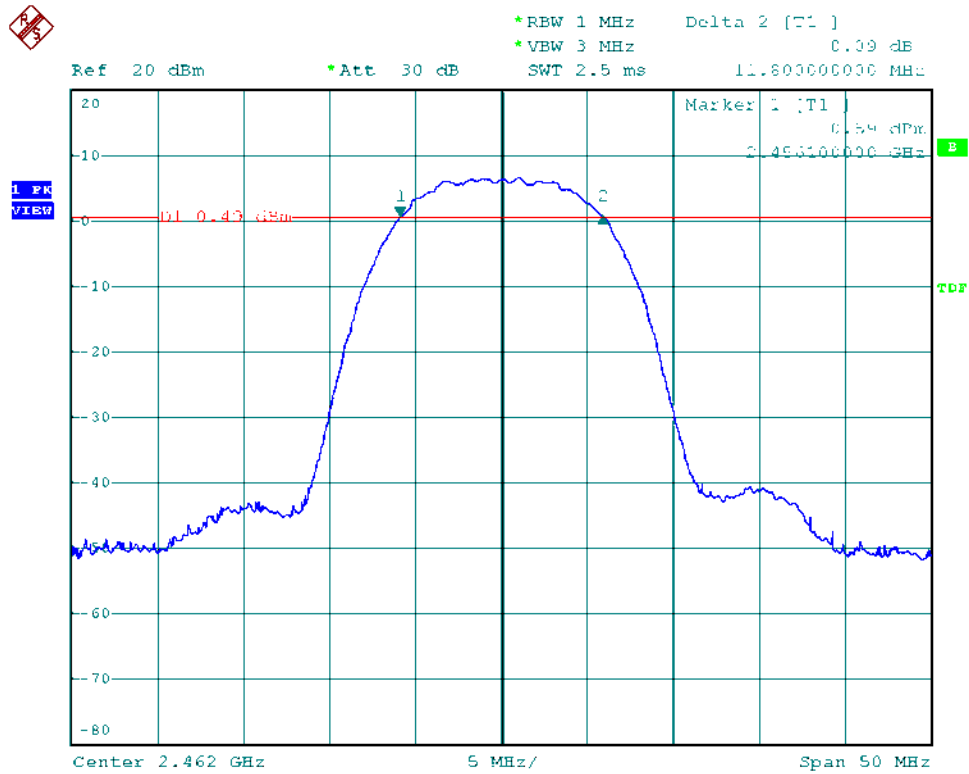

Modulation Standard: 802.11g (54Mbps), ANT R
Channel: 01

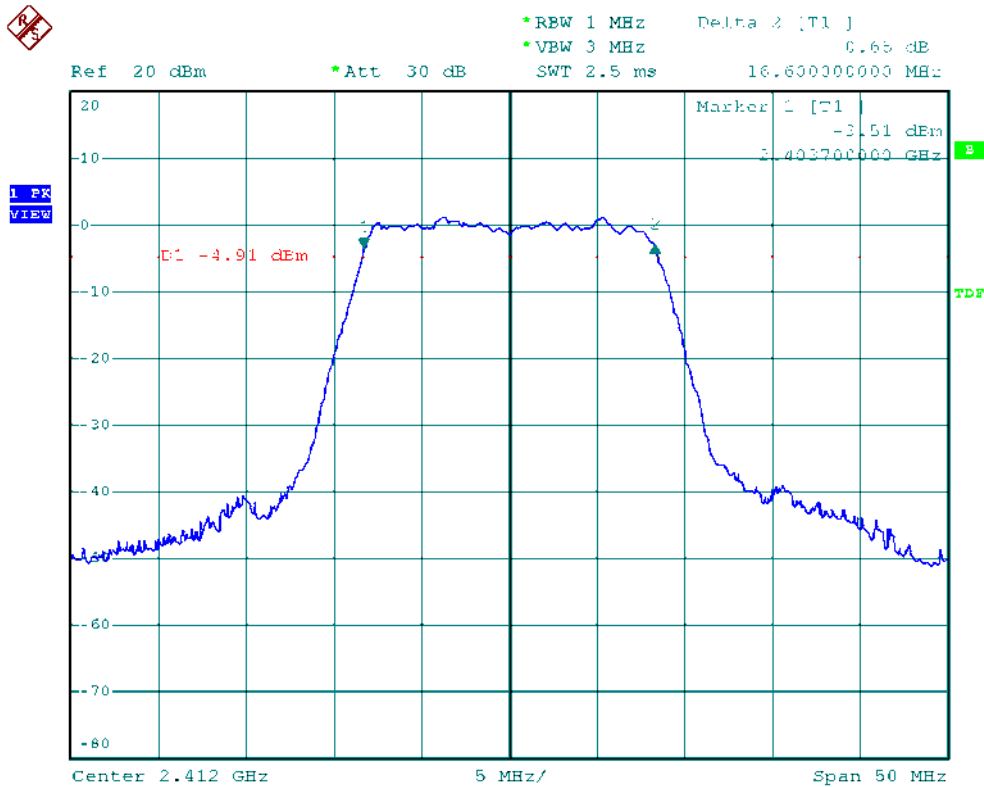



Modulation Standard: 802.11g (54Mbps), ANT R
Channel: 06

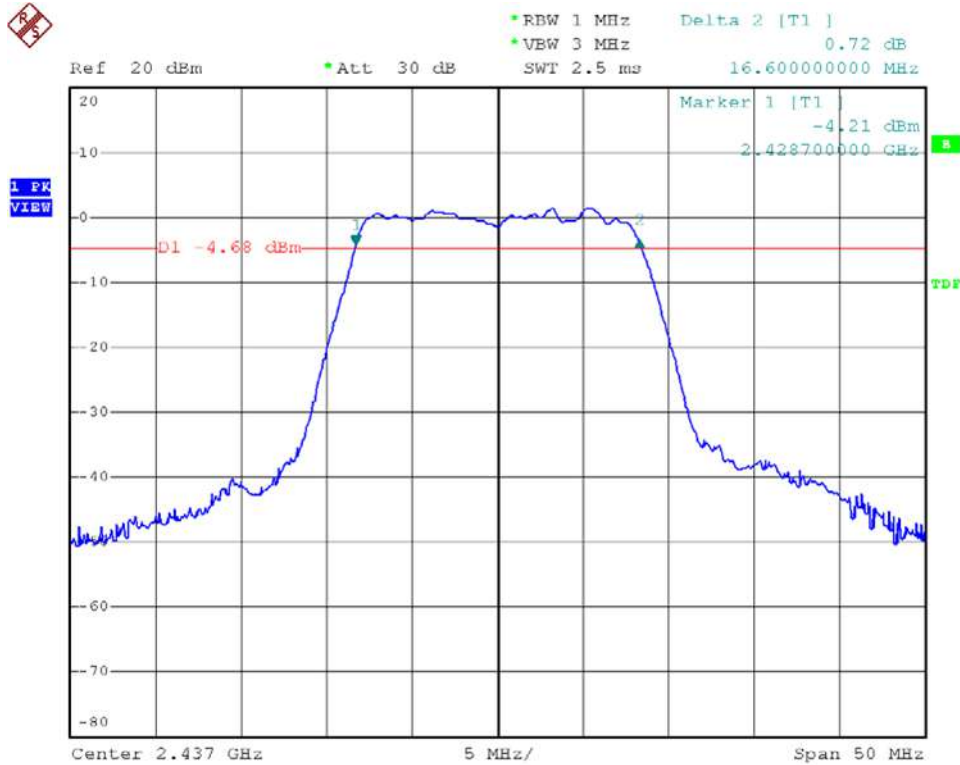

Modulation Standard: 802.11g (54Mbps), ANT R
Channel: 11

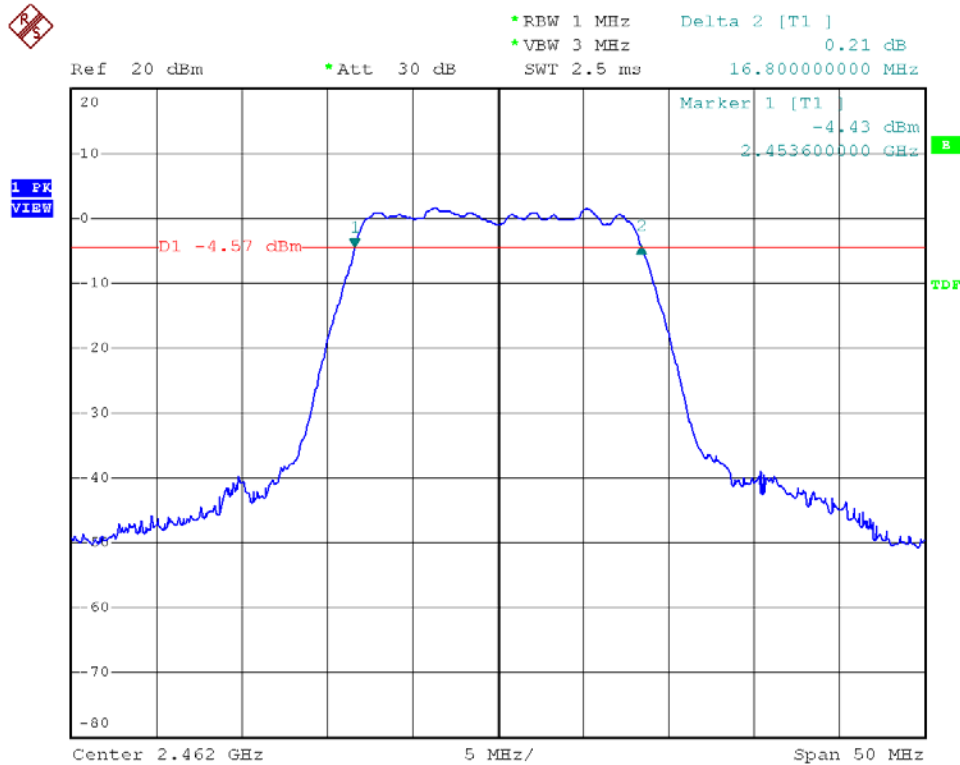



Modulation Standard: 802.11n HT20 (130Mbps), ANT R
Channel: 01

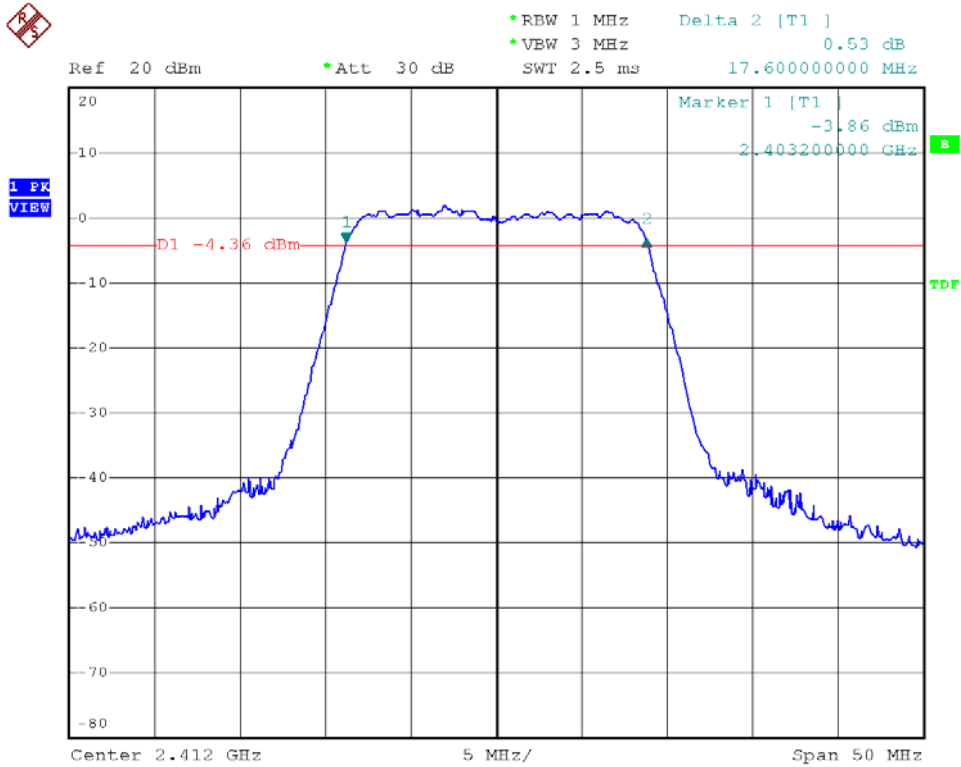

Modulation Standard: 802.11n HT20 (130Mbps), ANT R
Channel: 06

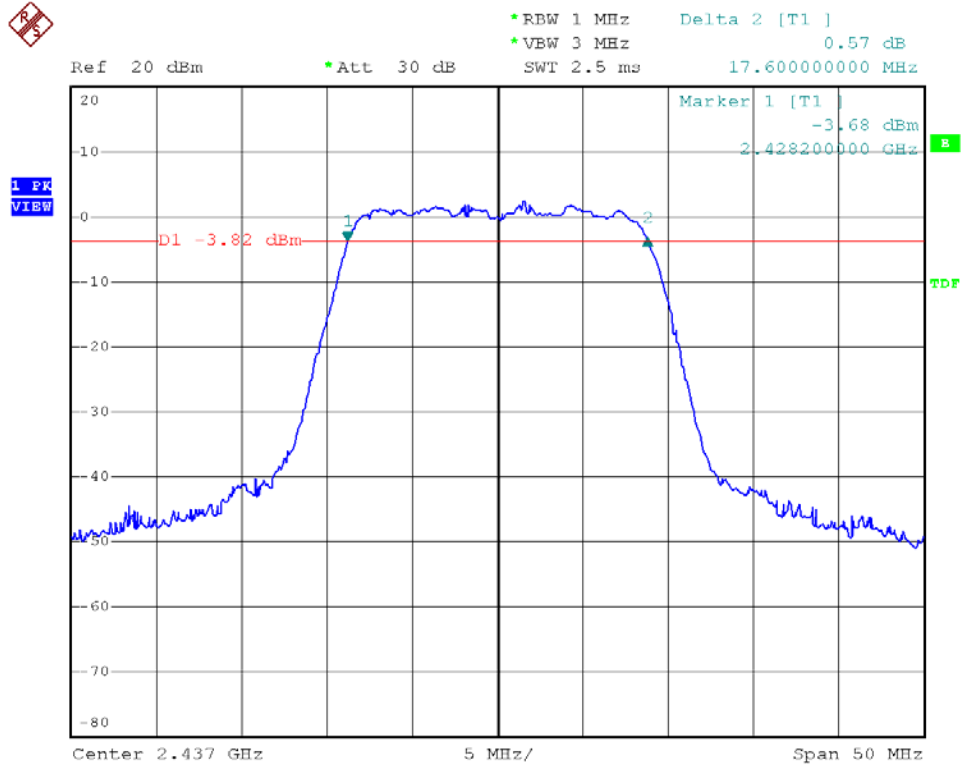



Modulation Standard: 802.11n HT20 (130Mbps), ANT R
Channel: 11

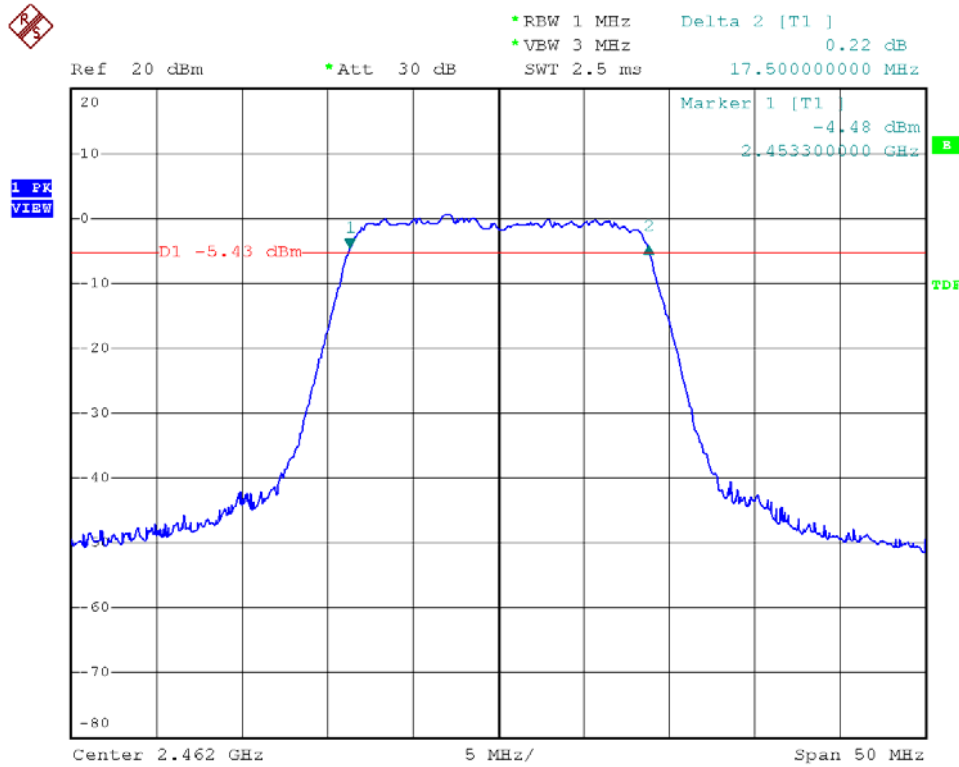

Modulation Standard: 802.11n HT40 (270Mbps), ANT R
Channel: 03

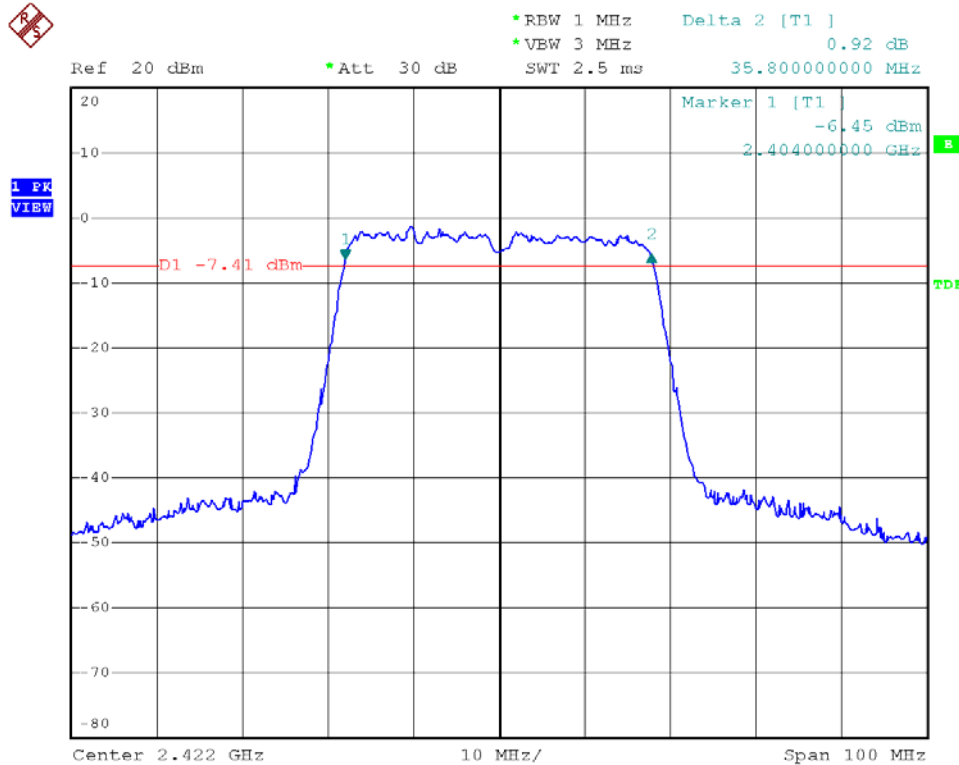



Modulation Standard: 802.11n HT40 (270Mbps), ANT R
Channel: 06

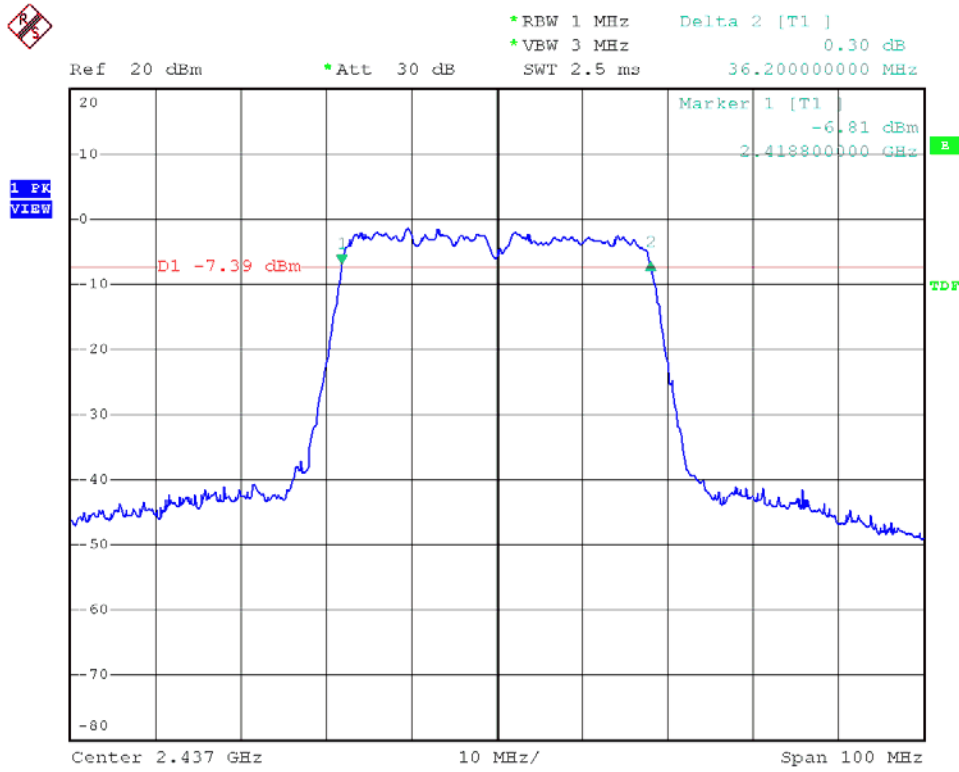

Modulation Standard: 802.11n HT40 (270Mbps), ANT R
Channel: 09

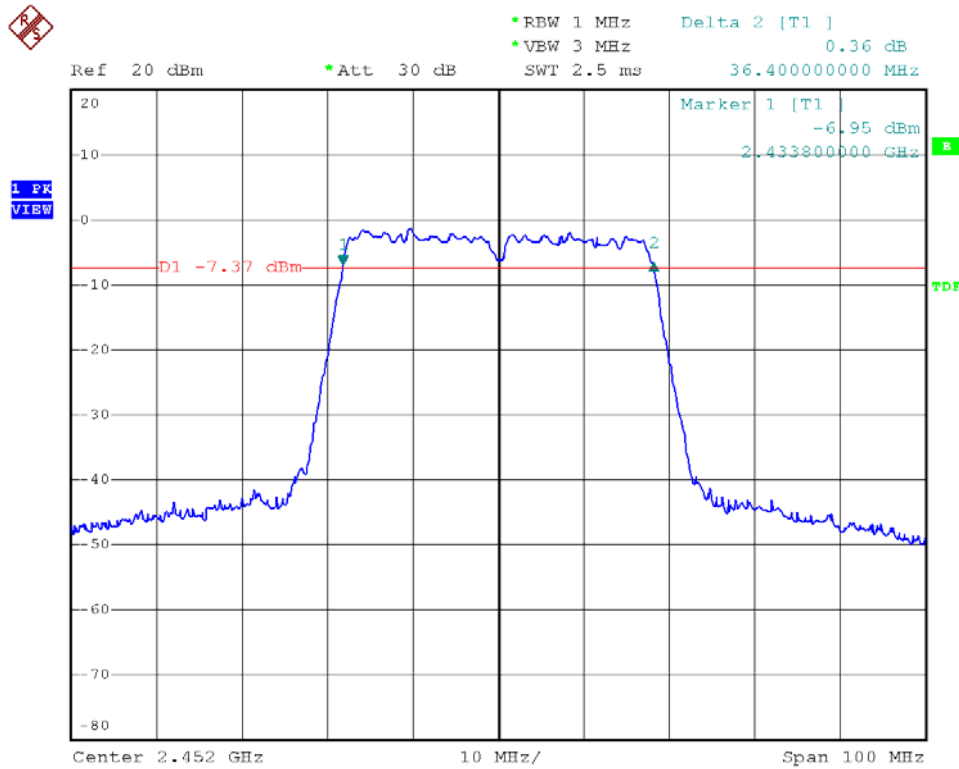



Modulation Standard: 802.11b (11Mbps), ANT L
Channel: 01

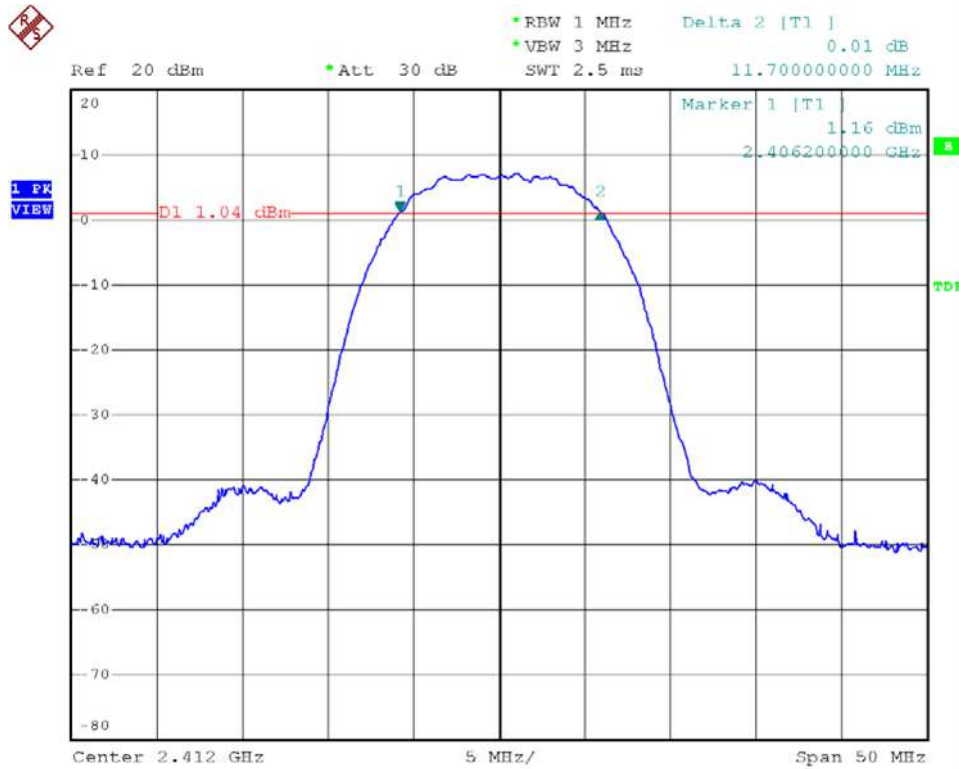

Modulation Standard: 802.11b (11Mbps), ANT L
Channel: 06

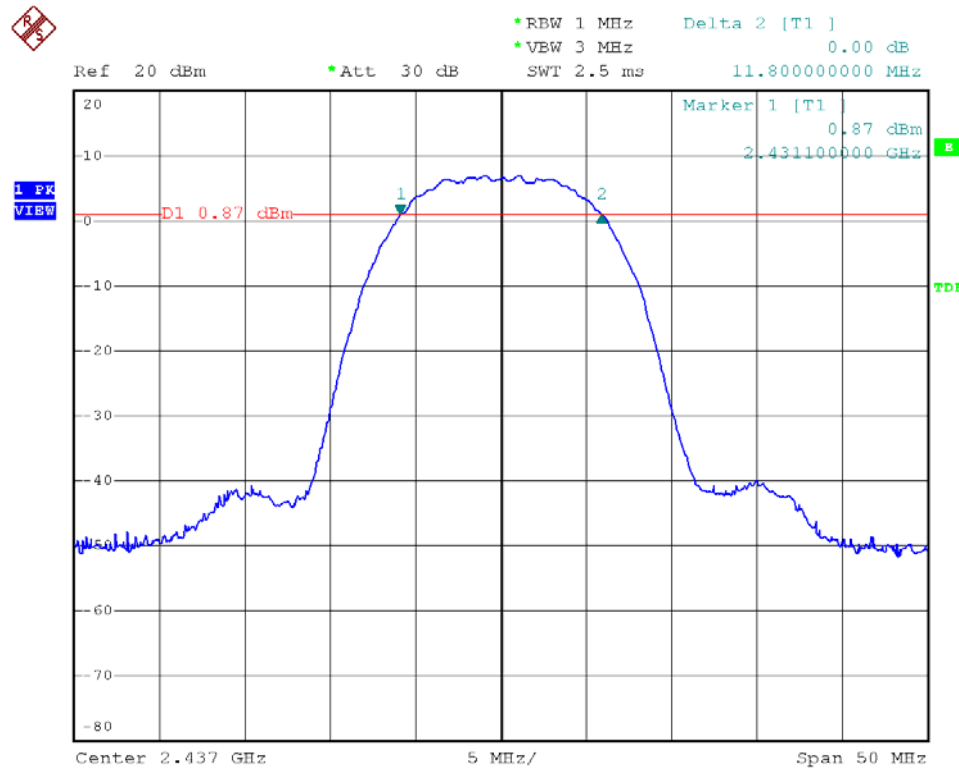



Modulation Standard: 802.11b (11Mbps), ANT L
Channel: 11

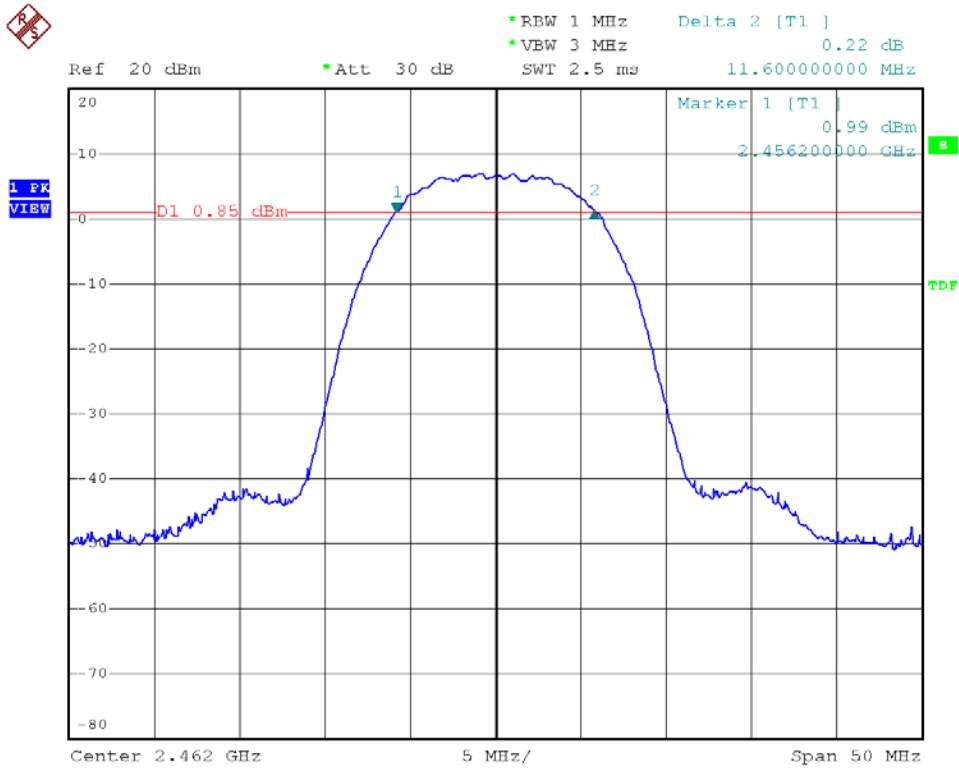

Modulation Standard: 802.11g (54Mbps), ANT L
Channel: 01

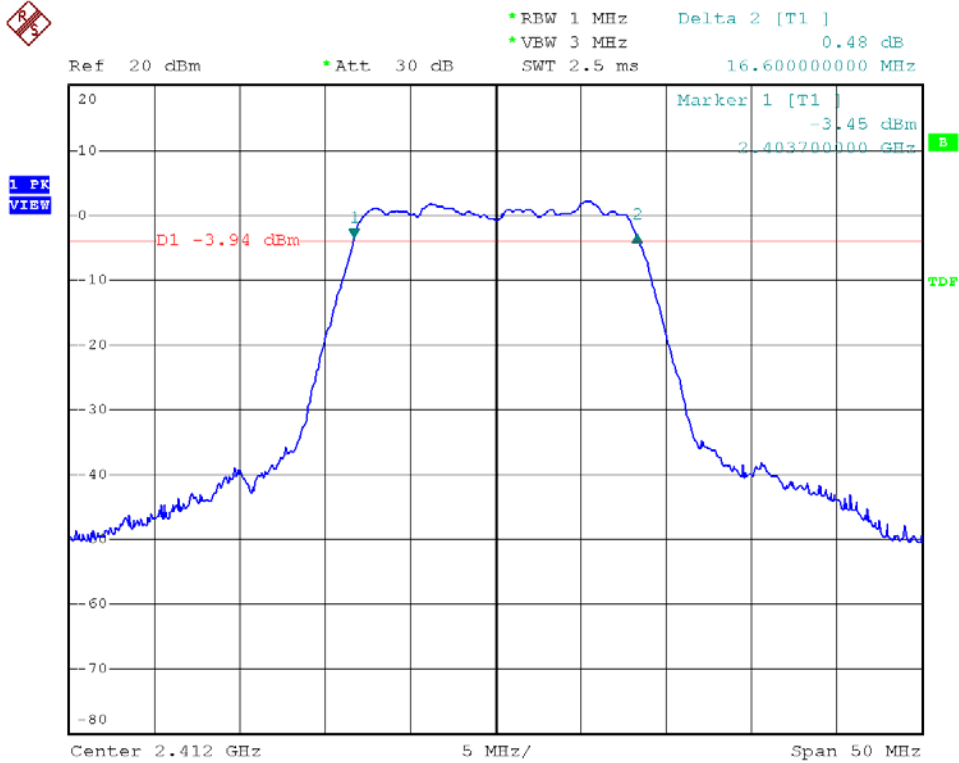



Modulation Standard: 802.11g (54Mbps), ANT L
Channel: 06

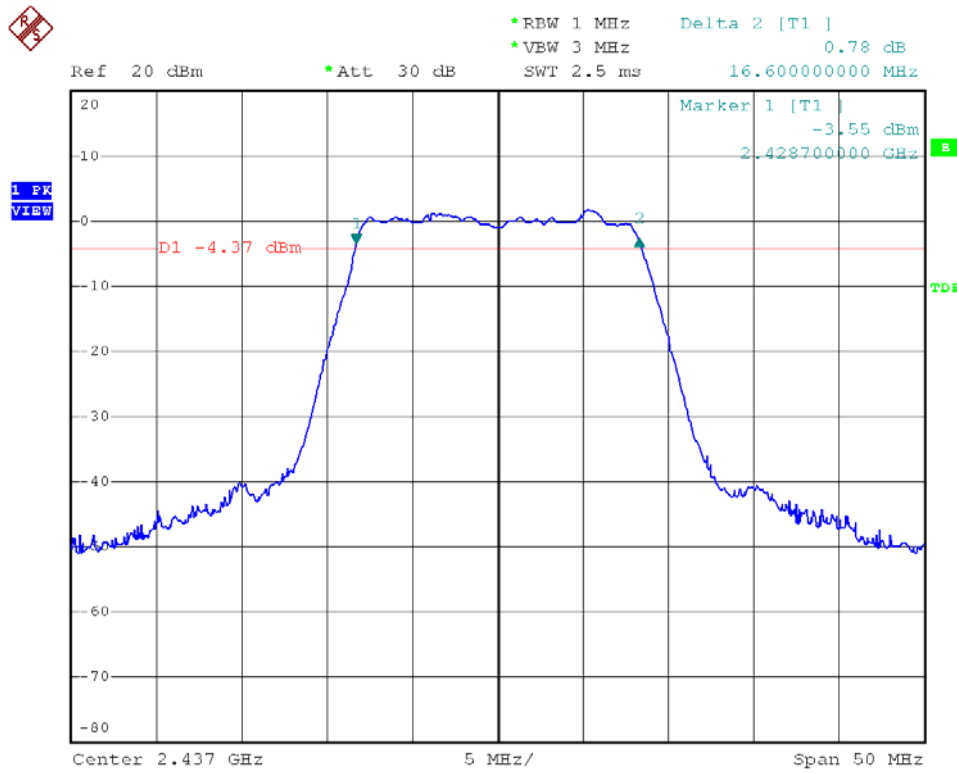

Modulation Standard: 802.11g (54Mbps), ANT L
Channel: 11

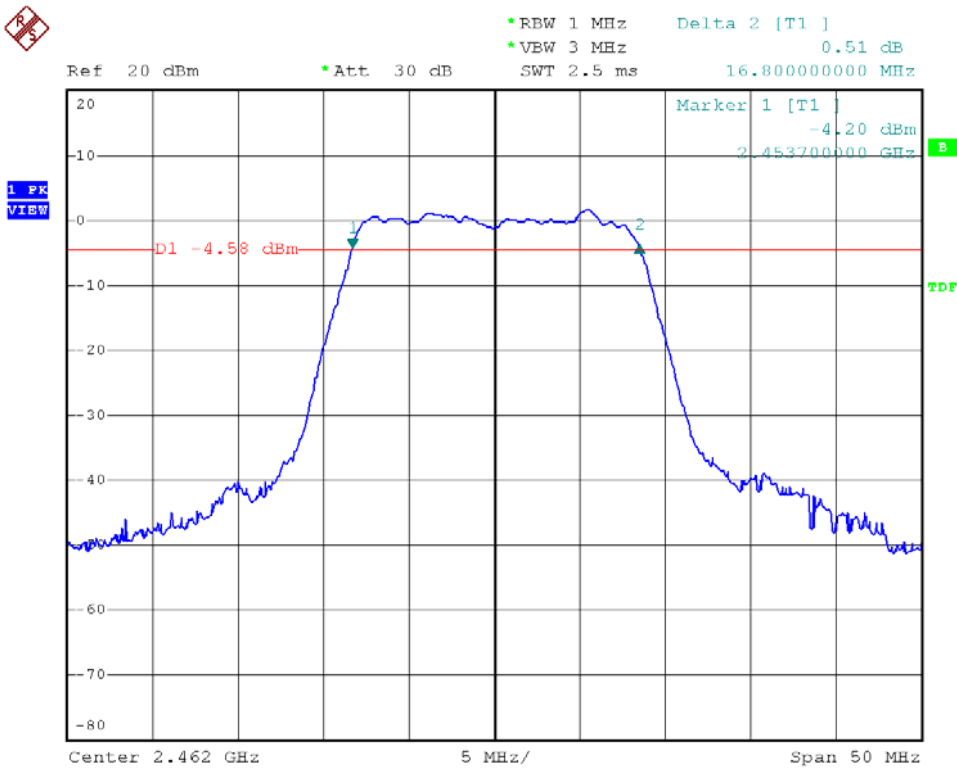



Modulation Standard: 802.11n HT20 (130Mbps), ANT L
Channel: 01

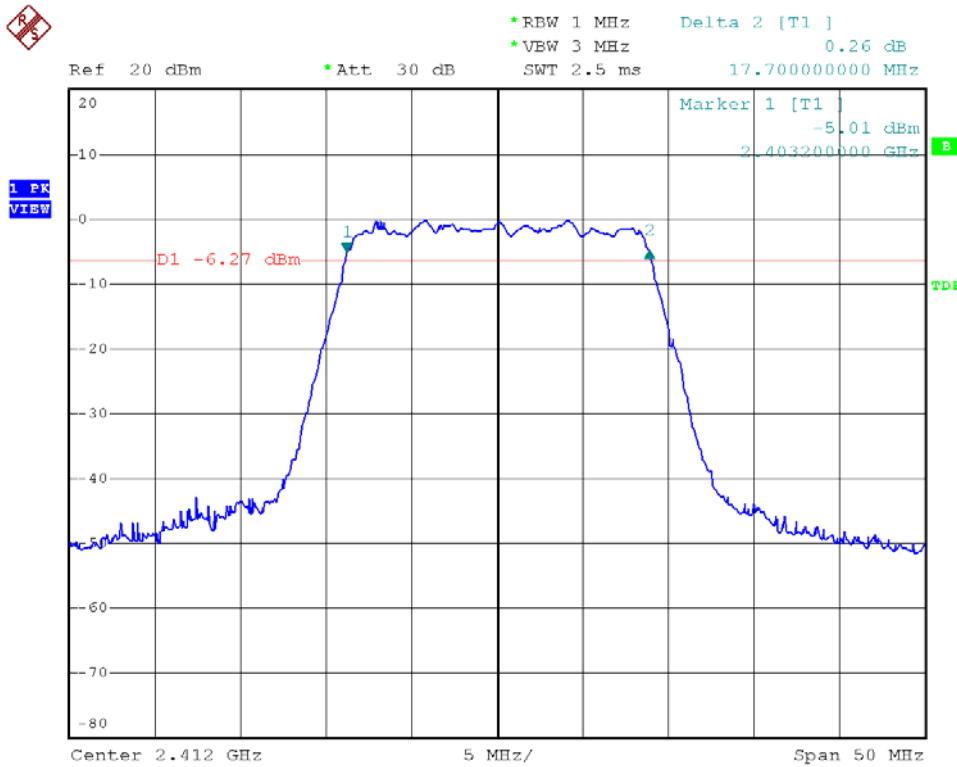

Modulation Standard: 802.11n HT20 (130Mbps), ANT L
Channel: 06

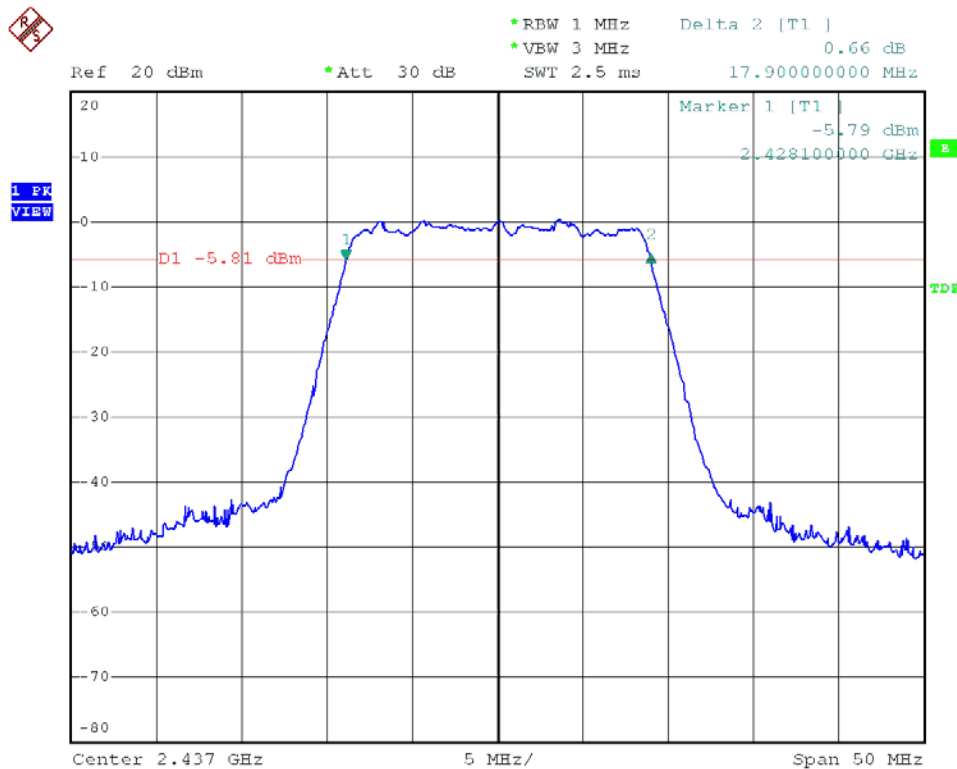



Modulation Standard: 802.11n HT20 (130Mbps), ANT L
Channel: 11

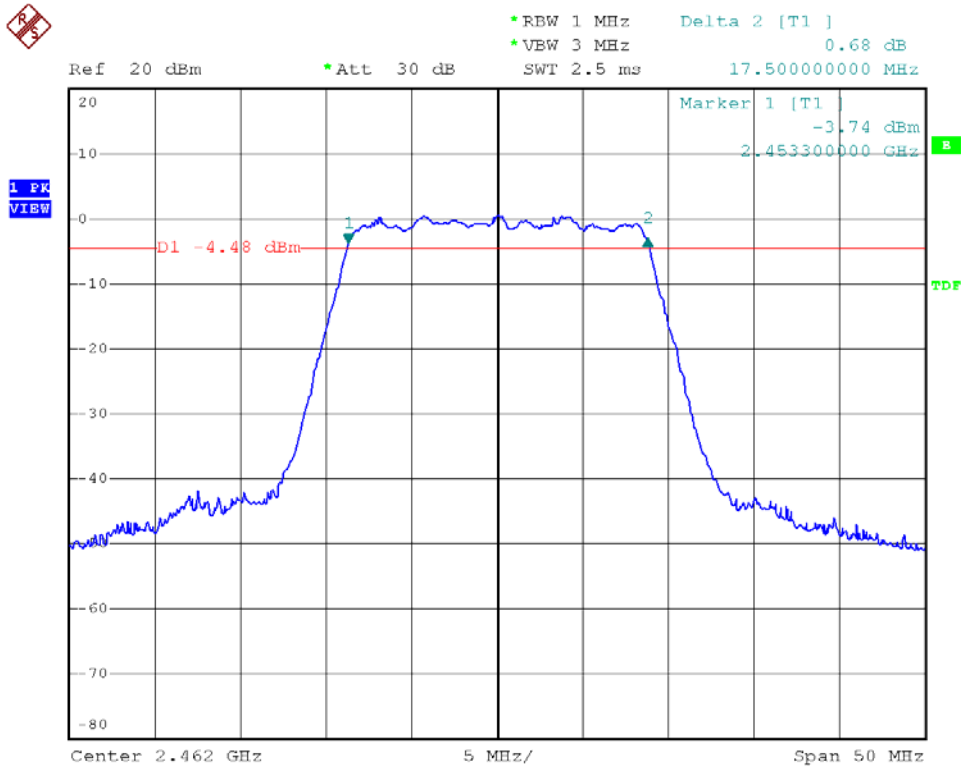

Modulation Standard: 802.11n HT40 (270Mbps), ANT L
Channel: 03

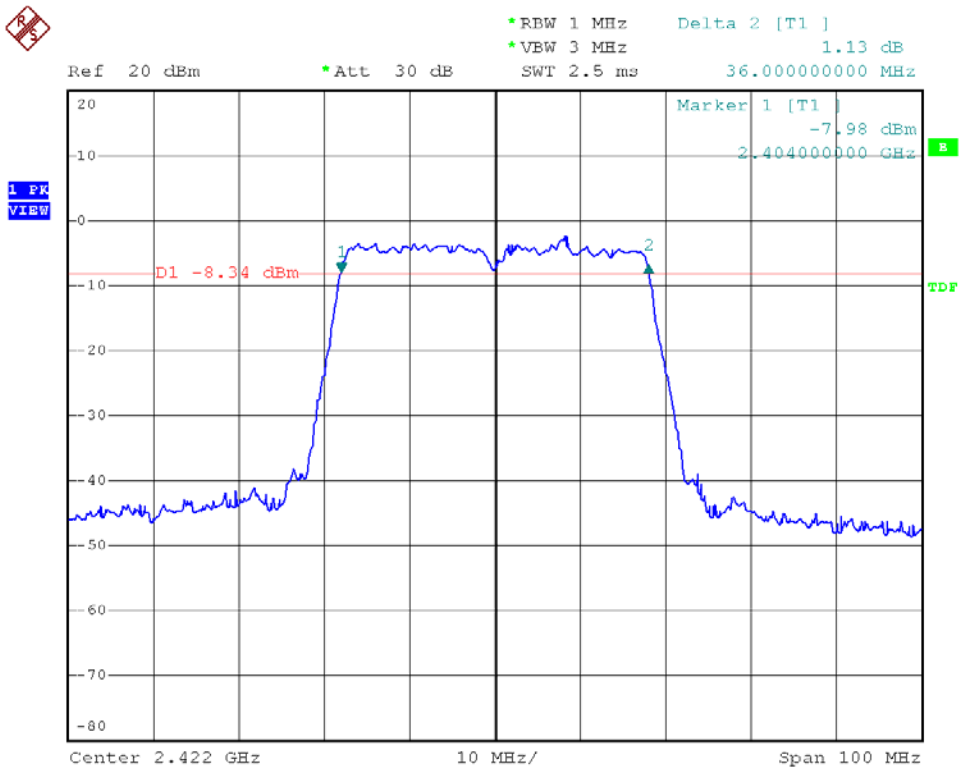



Modulation Standard: 802.11n HT40 (270Mbps), ANT L
Channel: 06

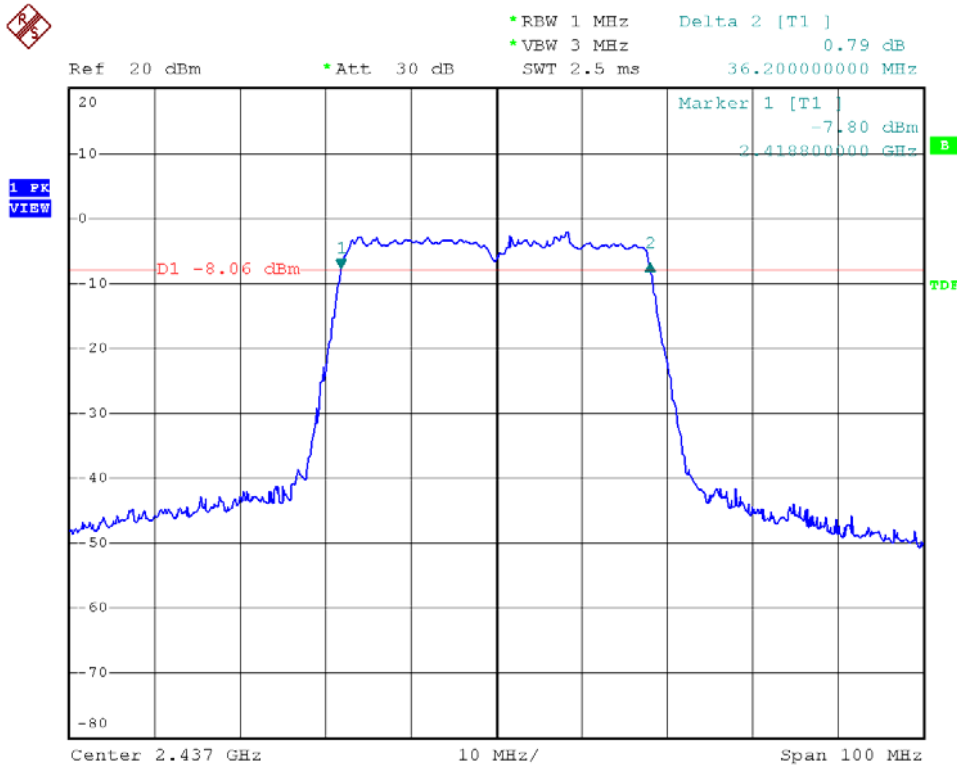

Modulation Standard: 802.11n HT40 (270Mbps), ANT L
Channel: 09

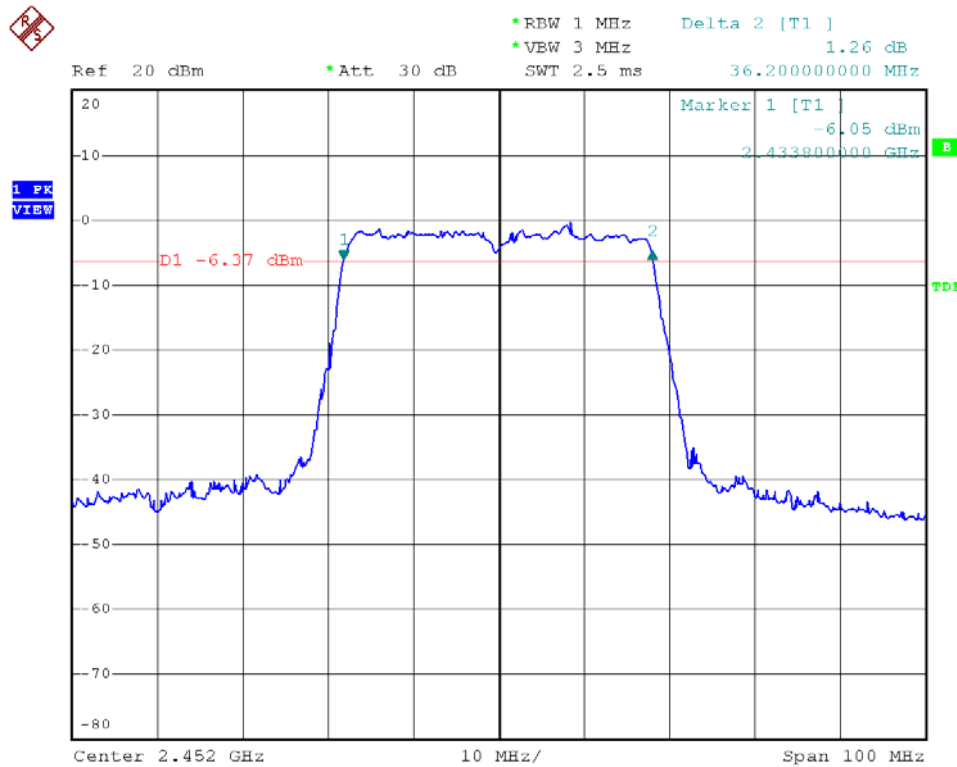



7. Maximum Peak and Average Output Power

7.1 Test Limit

The Maximum Peak Output Power Measurement is 30dBm.

7.2 Test Procedures

- a. The transmitter output was connected to the spectrum analyzer.
- b. Set RBW of spectrum analyzer to 1MHz and VBW to 3MHz.
- c. Set detector mode to peak (for peak output power) or set detector mode to RMS (for average output power). Trace averaging in power averaging (RMS) mode must be performed over a minimum of 100 traces.
- d. Use the spectrum analyzer's integrated band power measurement function with band limits set equal to the EBW band edges.
- e. The maximum peak and average output power was measured and recorded.

7.3 Test Setup Layout

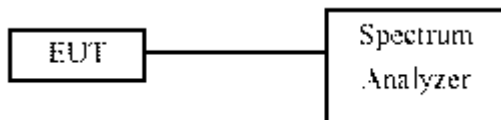

7.4 Measurement Equipment

Instrument/Ancillary	Manufacturer	Model No.	Serial No.	Calibration Date	Valid Date
Spectrum Analyzer	R&S	FSP40	100219	2011/11/24	2012/11/23



7.5 Test Result and Data

Test Date: Aug. 07, 2012

Temperature: 25°C

Atmospheric pressure: 1020 hPa

Humidity: 65%

Modulation Standard	Channel	Frequency (MHz)	Peak Power Output (dBm)			Peak Power Output (mW)
			ANT R	ANT L	R+L	R+L
802.11b (11Mbps)	01	2412	15.71	16.03	18.88	77.33
	06	2437	15.84	15.91	18.89	77.36
	11	2462	15.73	15.85	18.80	75.87
802.11g (54Mbps)	01	2412	11.90	12.31	15.12	32.51
	06	2437	11.80	12.01	14.92	31.02
	11	2462	12.06	11.86	14.97	31.42

Modulation Standard	Channel	Frequency (MHz)	Peak Power Output (dBm)			Peak Power Output (mW)
			ANT R	ANT L	R+L	R+L
802.11n HT20 (130Mbps)	01	2412	11.03	10.86	13.96	24.87
	06	2437	11.05	11.00	14.04	25.32
	11	2462	10.85	10.89	13.88	24.44
802.11n HT40 (270Mbps)	03	2422	10.72	10.95	13.85	24.25
	06	2437	10.67	11.01	13.85	24.29
	09	2452	10.86	11.12	14.00	25.13



Test Date: Aug. 07, 2012

Temperature: 25°C

Atmospheric pressure: 1020 hPa

Humidity: 65%

Modulation Standard	Channel	Frequency (MHz)	Peak Power Output (dBm)			Average Power Output (mW)
			ANT R	ANT L	R+L	R+L
802.11b (11Mbps)	01	2412	11.55	11.79	14.68	29.39
	06	2437	11.57	11.56	14.58	28.68
	11	2462	11.43	11.57	14.51	28.25
802.11g (54Mbps)	01	2412	5.20	5.79	8.52	7.10
	06	2437	5.39	5.73	8.57	7.20
	11	2462	5.16	5.42	8.30	6.76

Modulation Standard	Channel	Frequency (MHz)	Peak Power Output (dBm)			Average Power Output (mW)
			ANT R	ANT L	R+L	R+L
802.11n HT20 (130Mbps)	01	2412	5.10	5.03	8.08	6.42
	06	2437	5.18	5.16	8.18	6.58
	11	2462	5.45	5.89	8.69	7.39
802.11n HT40 (270Mbps)	03	2422	5.28	4.99	8.15	6.53
	06	2437	5.09	4.92	8.02	6.33
	09	2452	5.56	5.89	8.74	7.48



Modulation Standard: 802.11b (11Mbps), ANT R, Peak Power Output Channel: 01

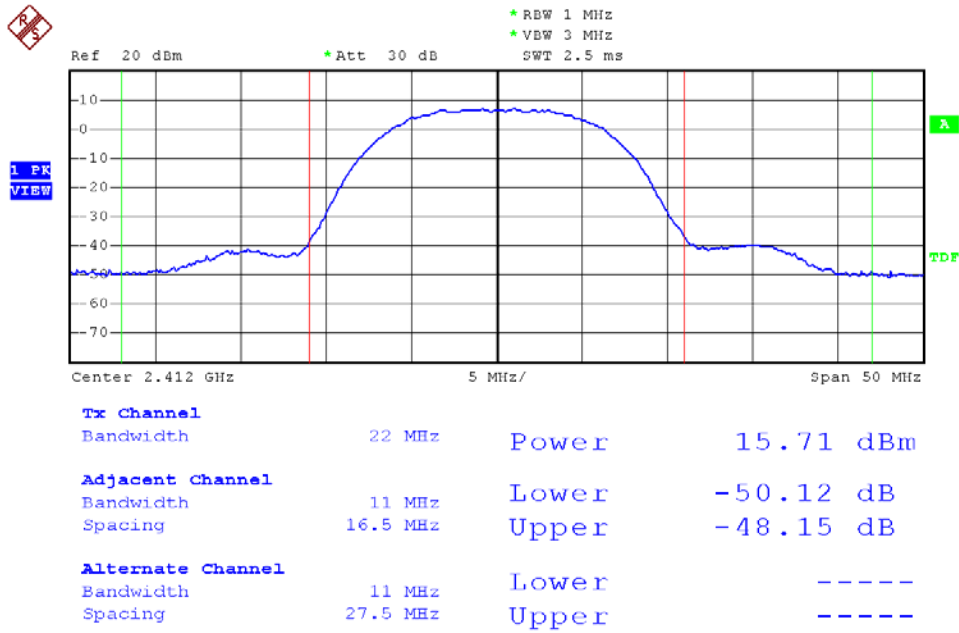

Modulation Standard: 802.11b (11Mbps), ANT R, Peak Power Output Channel: 06

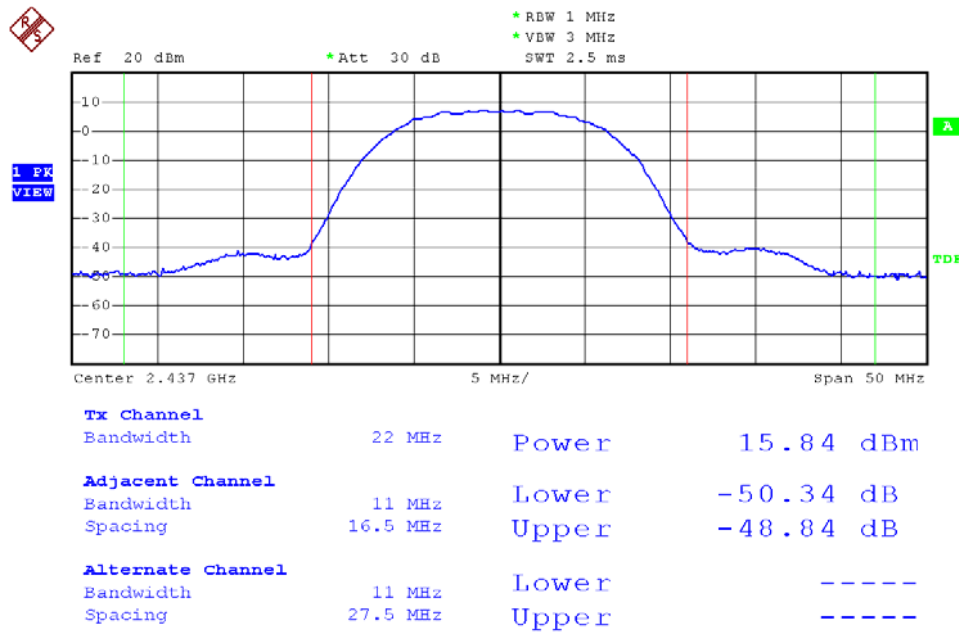



Modulation Standard: 802.11b (11Mbps), ANT R, Peak Power Output Channel: 11

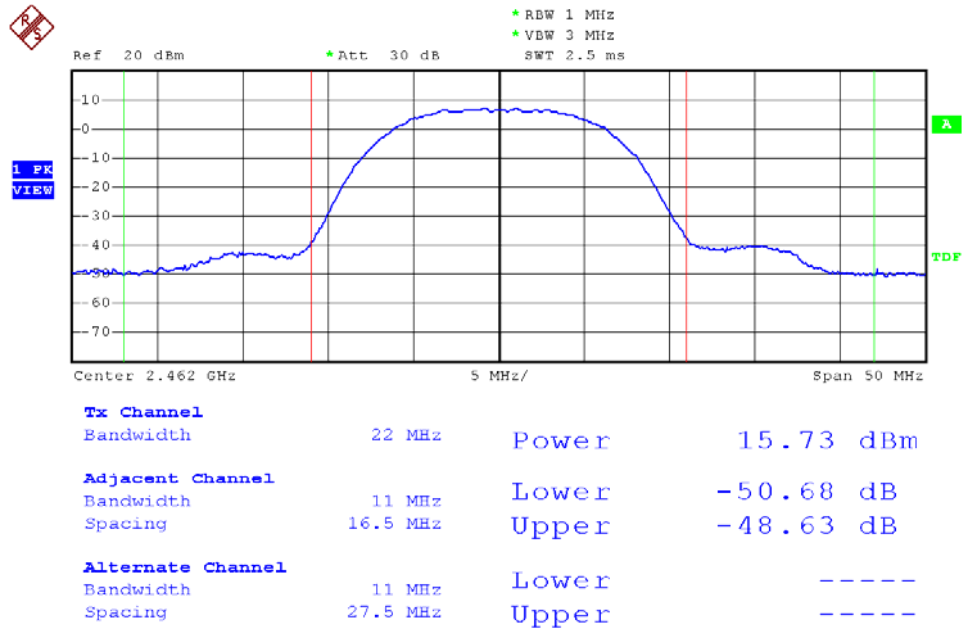

Modulation Standard: 802.11g (54Mbps), ANT R, Peak Power Output Channel: 01

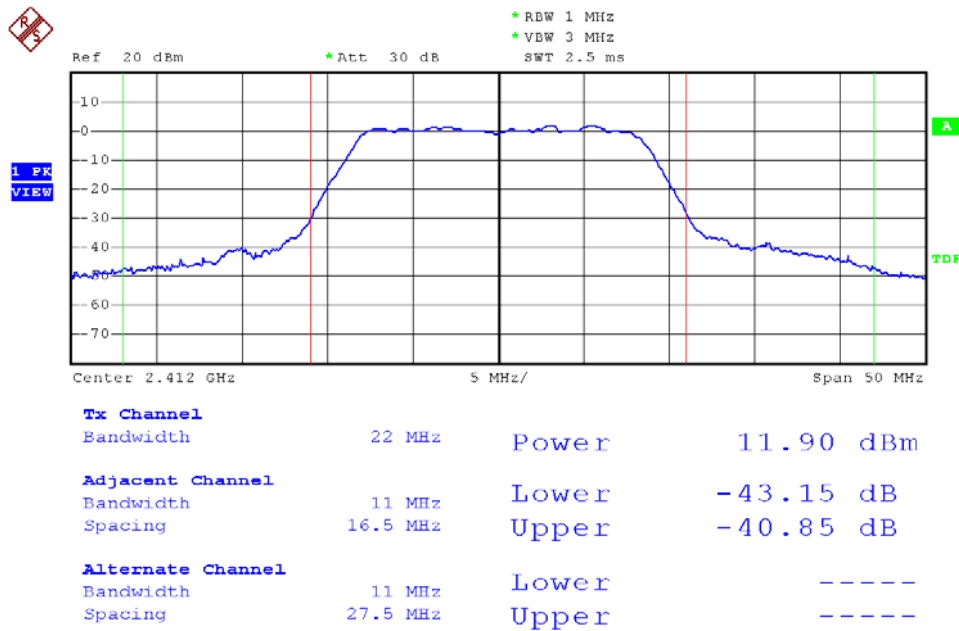



Modulation Standard: 802.11g (54Mbps), ANT R, Peak Power Output Channel: 06

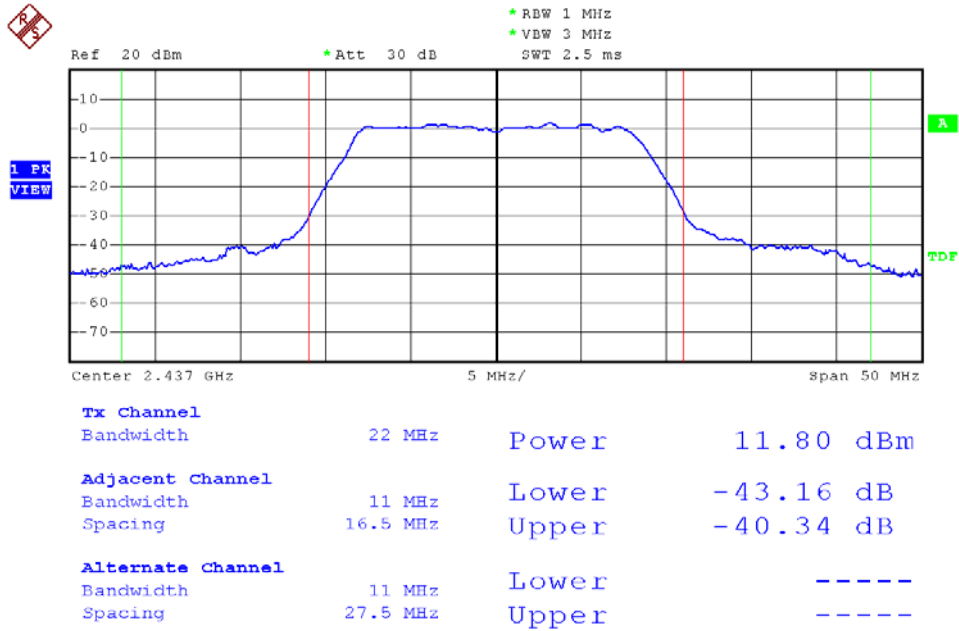

Modulation Standard: 802.11g (6Mbps), ANT R, Peak Power Output Channel: 11

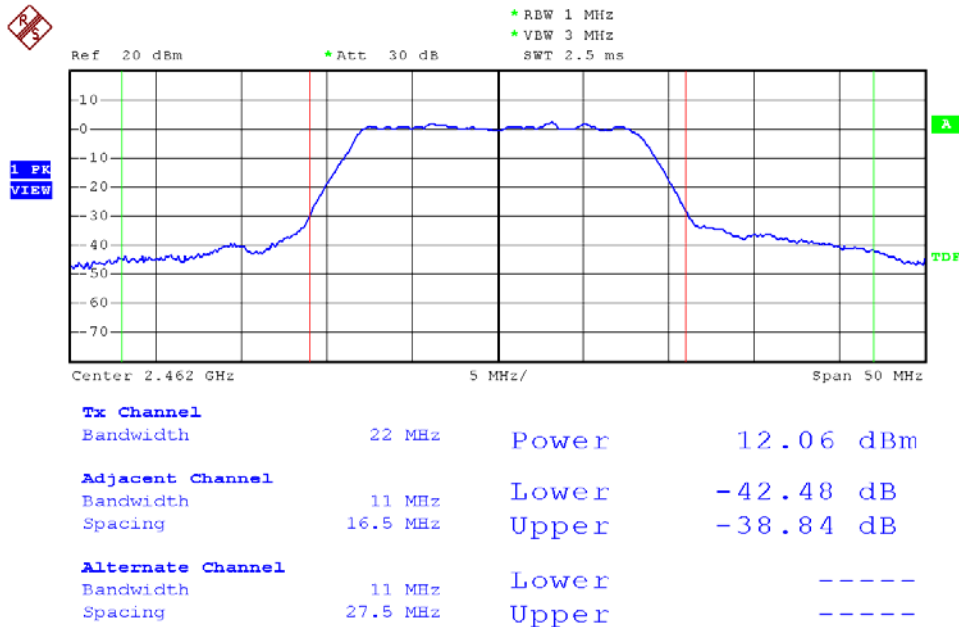



Modulation Standard: 802.11n HT20 (130Mbps), ANT R, Peak Power Output Channel: 01

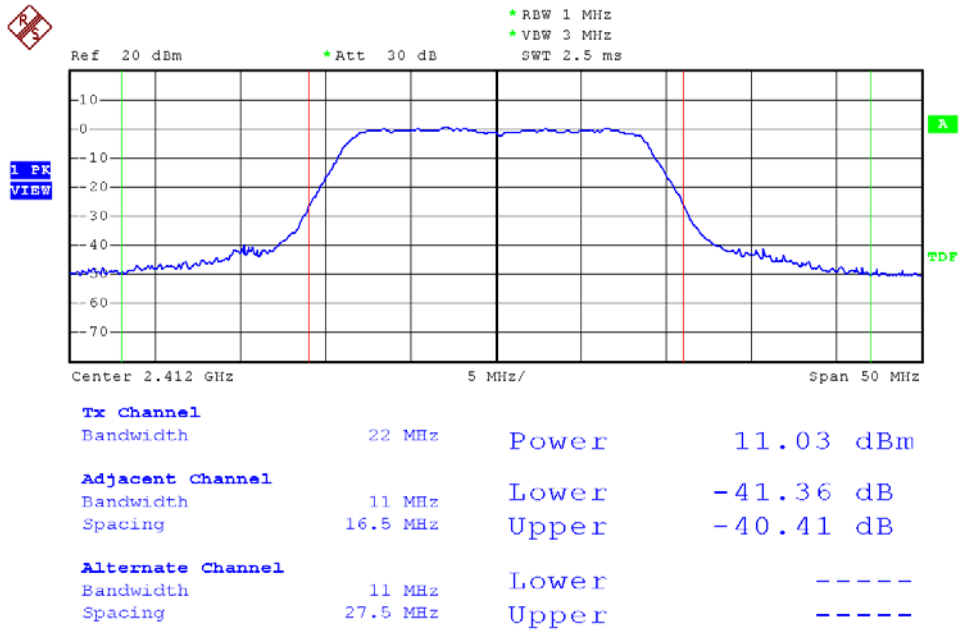

Modulation Standard: 802.11n HT20 (130Mbps), ANT R, Peak Power Output Channel: 06

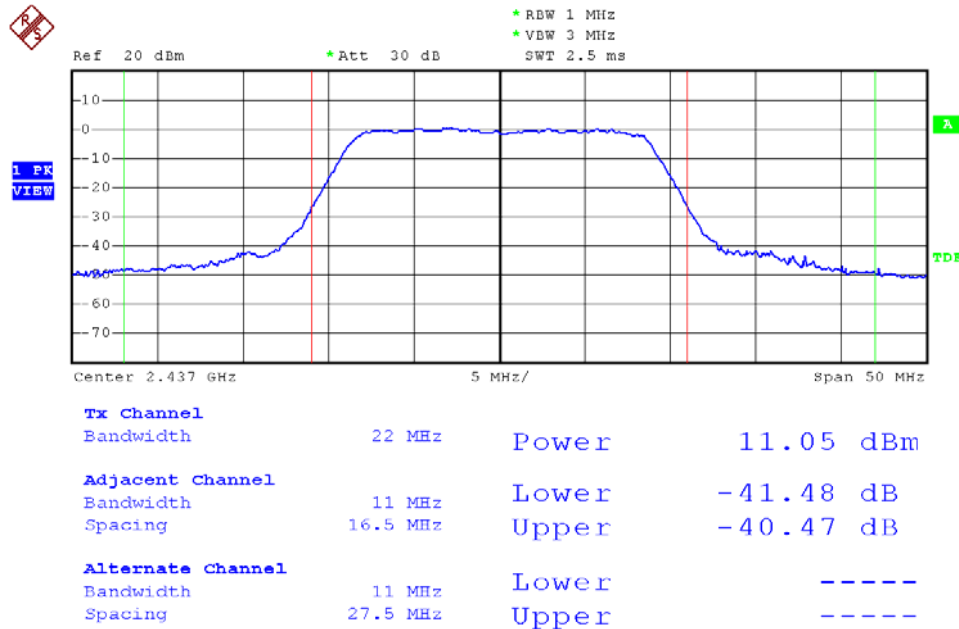



Modulation Standard: 802.11n HT20 (130Mbps), ANT R, Peak Power Output Channel: 11

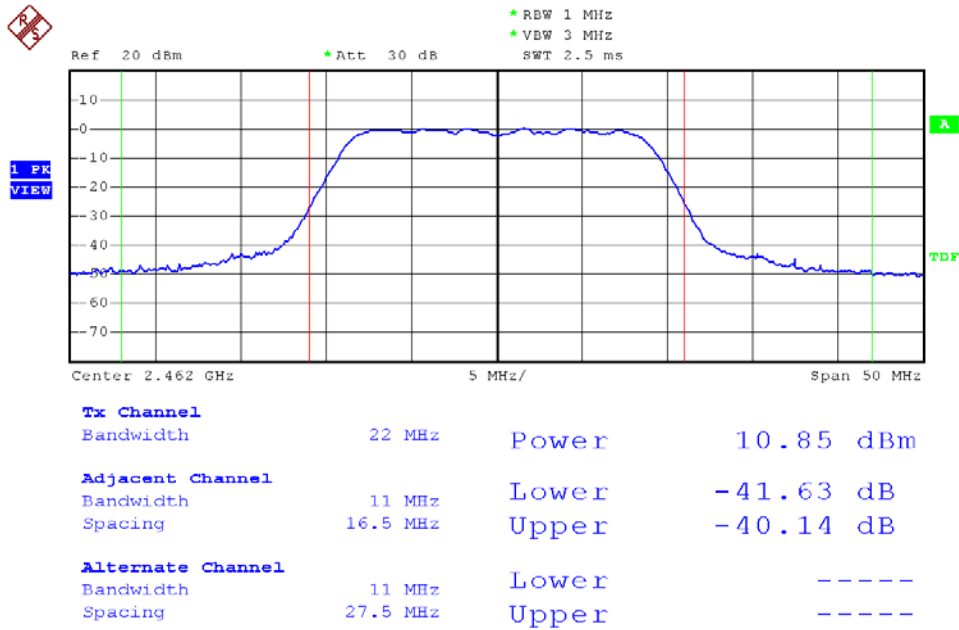

Modulation Standard: 802.11n HT40 (270Mbps), ANT R, Peak Power Output Channel: 03

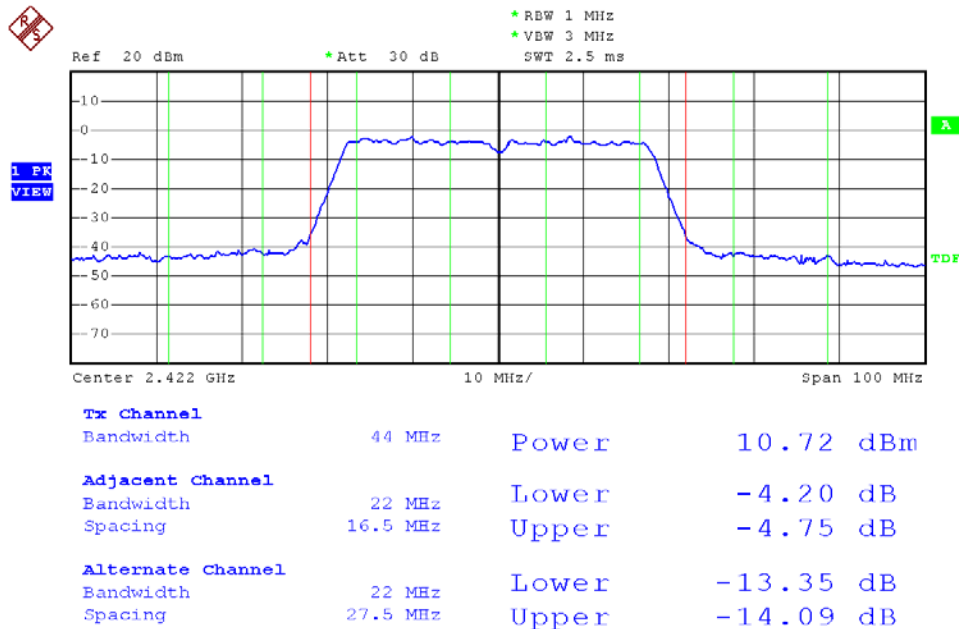



Modulation Standard: 802.11n HT40 (270Mbps), ANT R, Peak Power Output Channel: 06

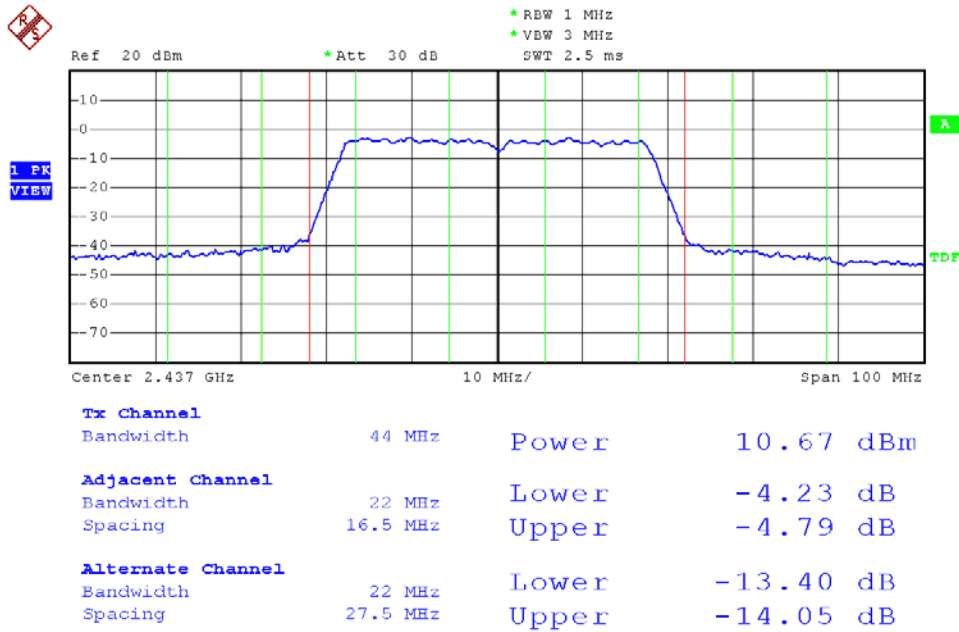

Modulation Standard: 802.11n HT40 (270Mbps), ANT R, Peak Power Output Channel: 09

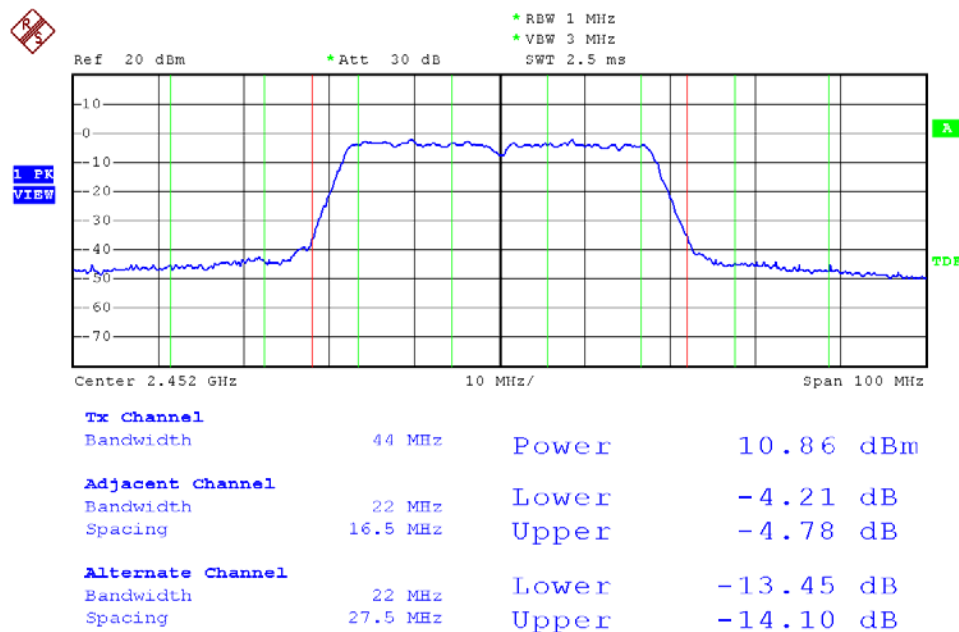



Modulation Standard: 802.11b (11Mbps), ANT L, Peak Power Output Channel: 01

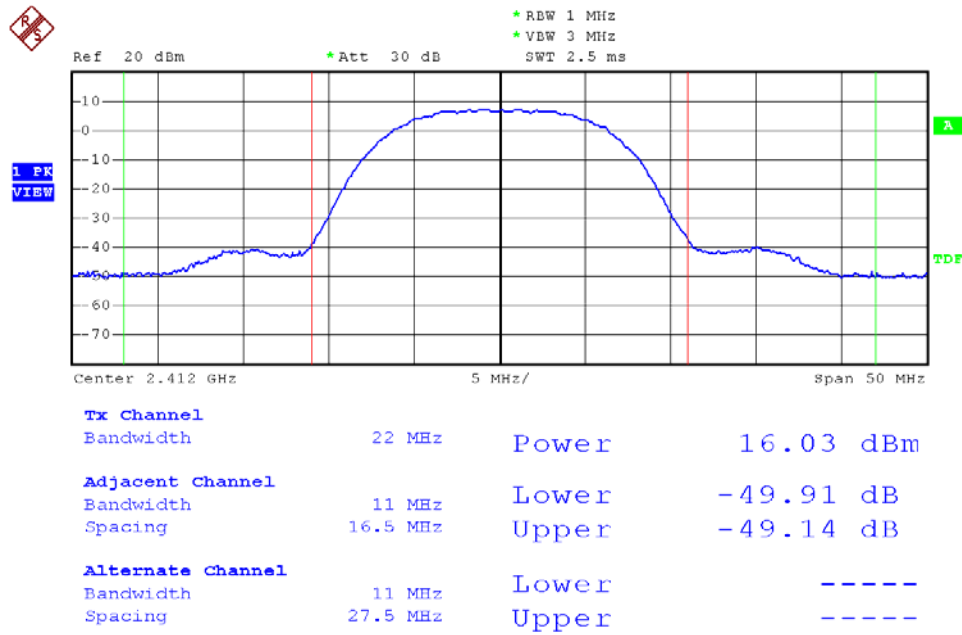

Modulation Standard: 802.11b (11Mbps), ANT L, Peak Power Output Channel: 06

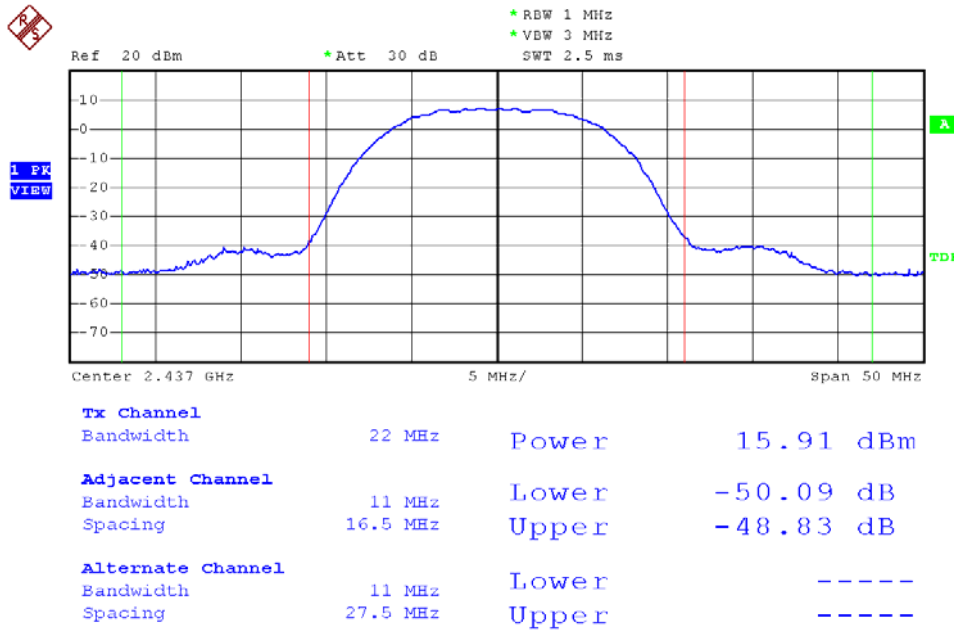



Modulation Standard: 802.11b (11Mbps), ANT L, Peak Power Output Channel: 11

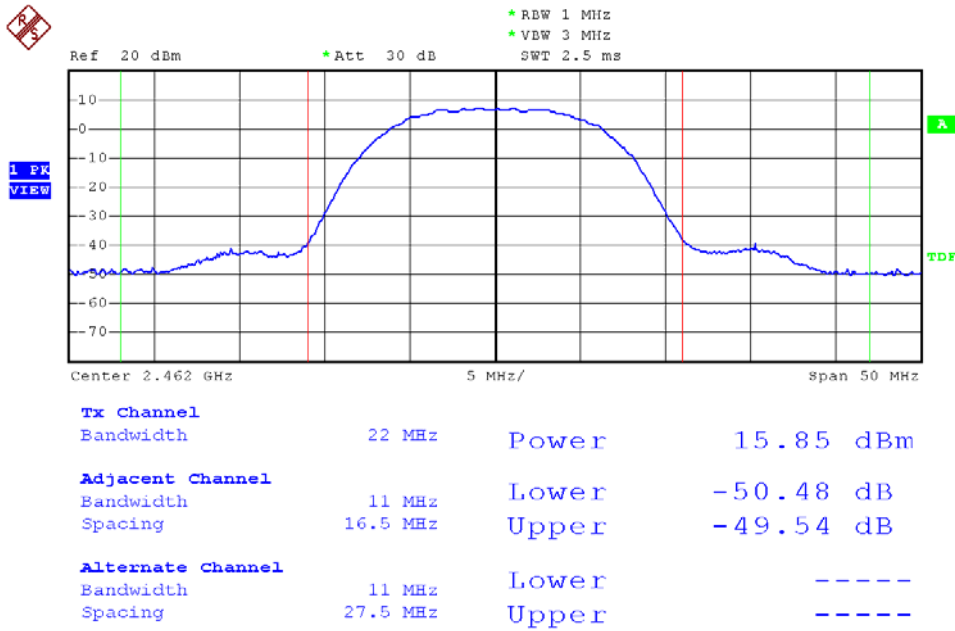

Modulation Standard: 802.11g (54Mbps), ANT L, Peak Power Output Channel: 01

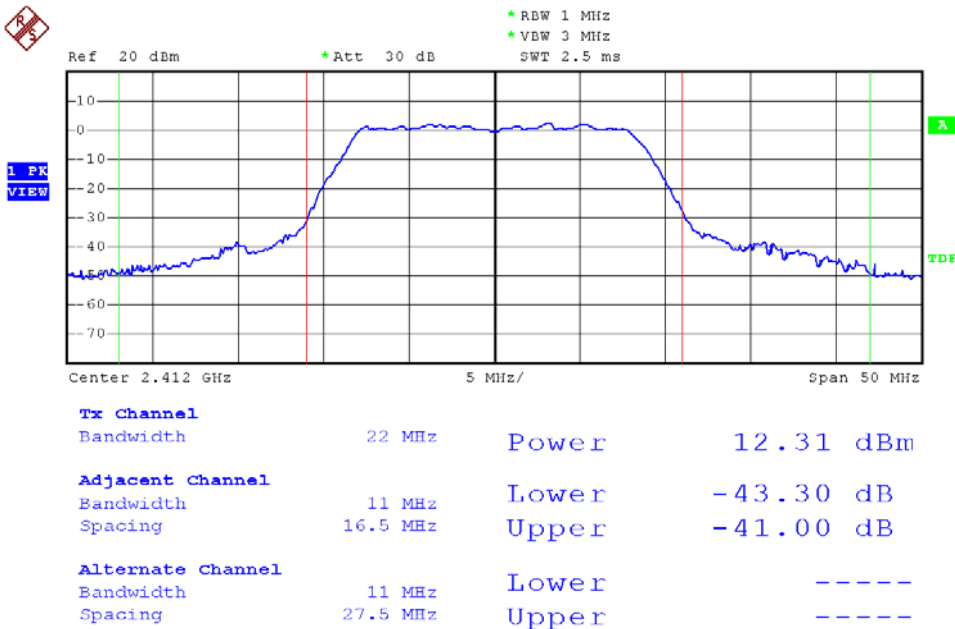



Modulation Standard: 802.11g (54Mbps), ANT L, Peak Power Output Channel: 06

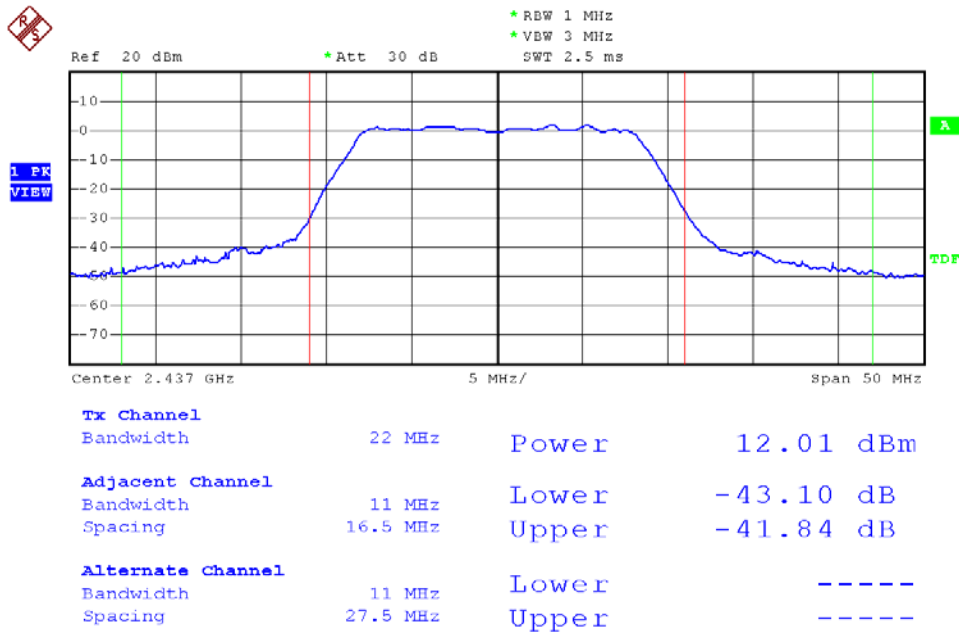

Modulation Standard: 802.11g (54Mbps), ANT L, Peak Power Output Channel: 11

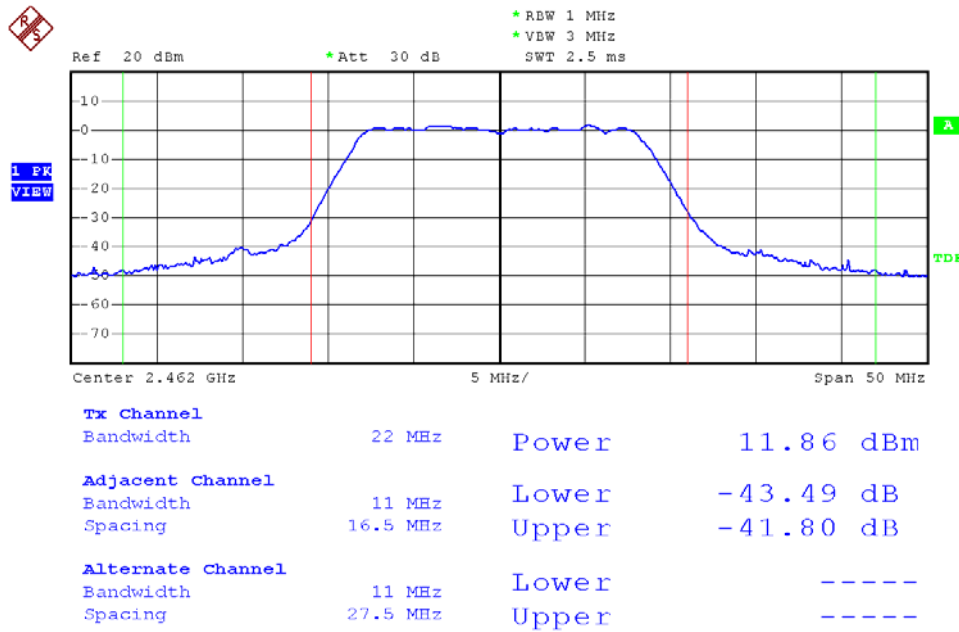



Modulation Standard: 802.11n HT20 (130Mbps), ANT L, Peak Power Output Channel: 01

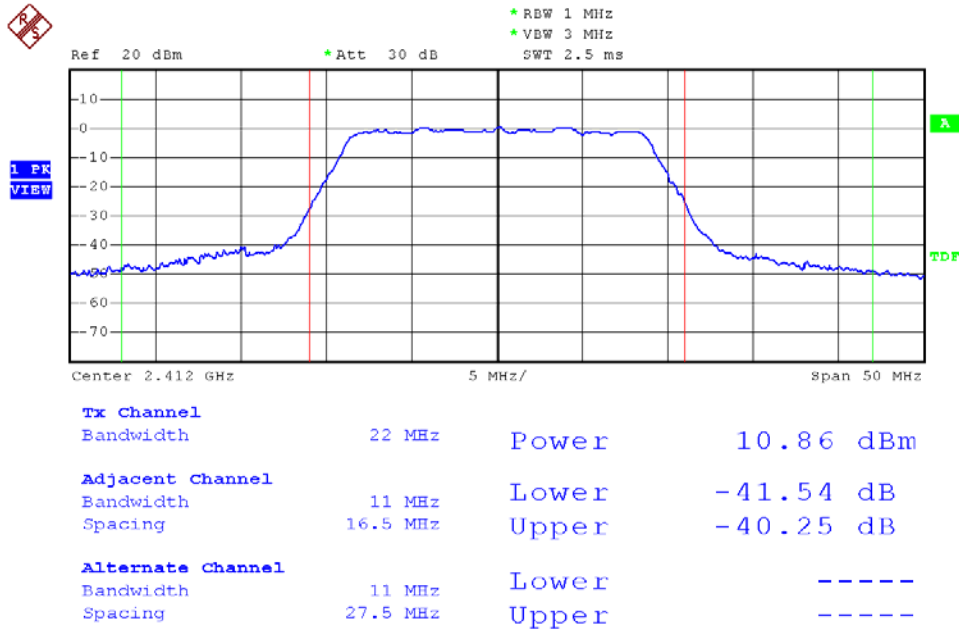

Modulation Standard: 802.11n HT20 (130Mbps), ANT L, Peak Power Output Channel: 06

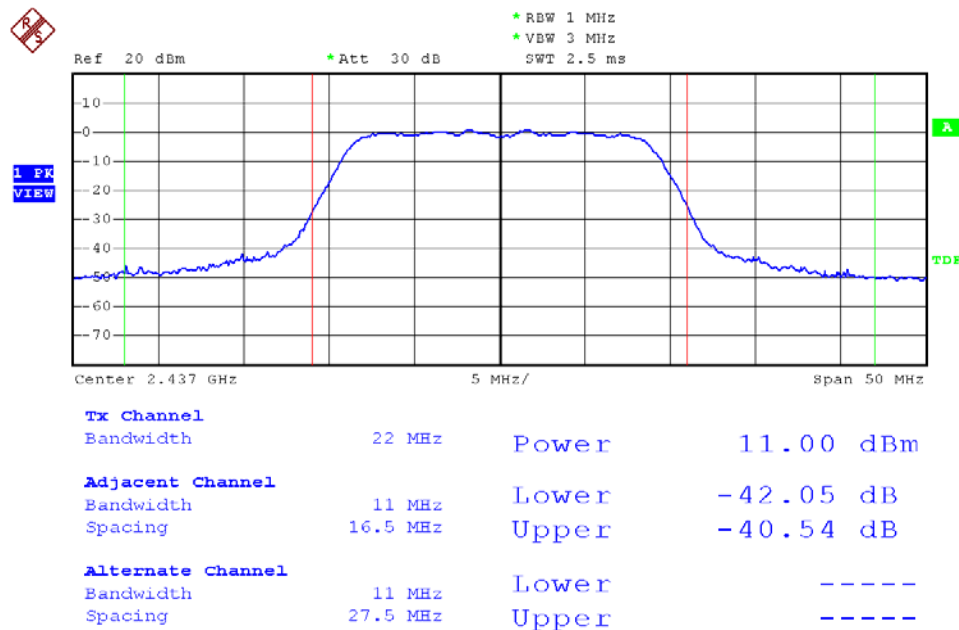



Modulation Standard: 802.11n HT20 (130Mbps), ANT L, Peak Power Output Channel: 11

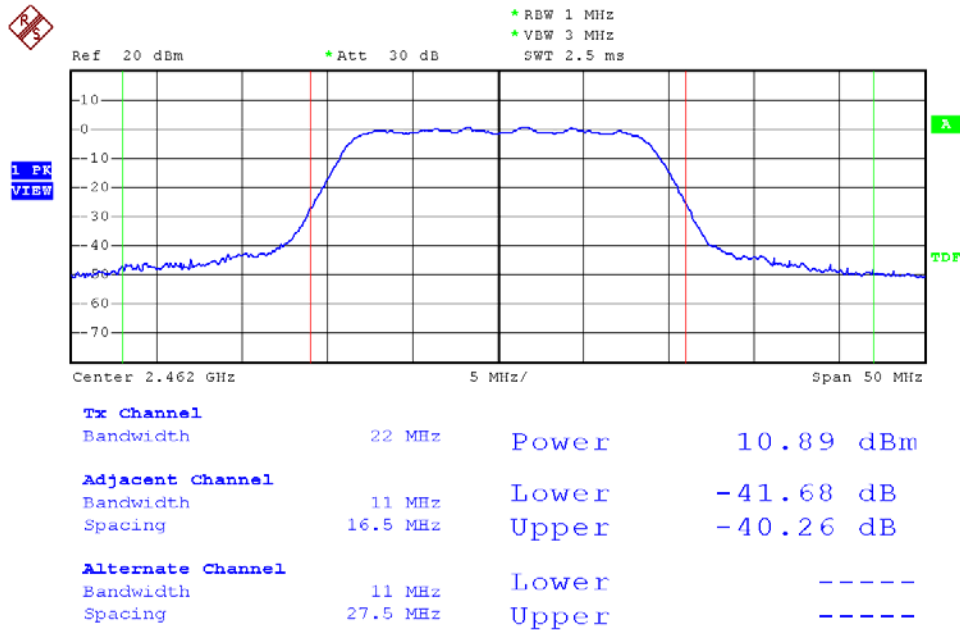

Modulation Standard: 802.11n HT40 (270Mbps), ANT L, Peak Power Output Channel: 03

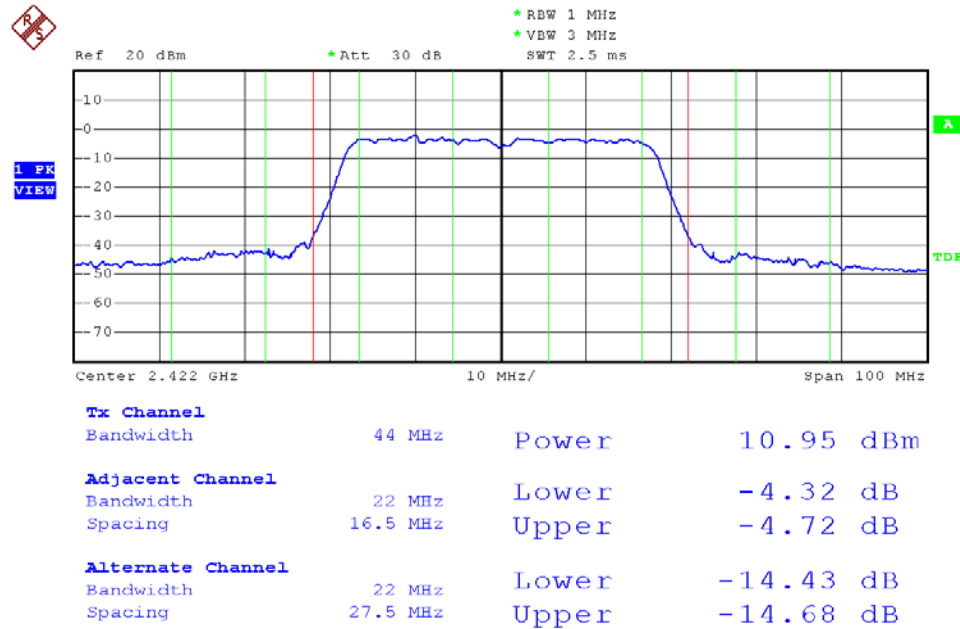



Modulation Standard: 802.11n HT40 (270Mbps), ANT L, Peak Power Output Channel: 06

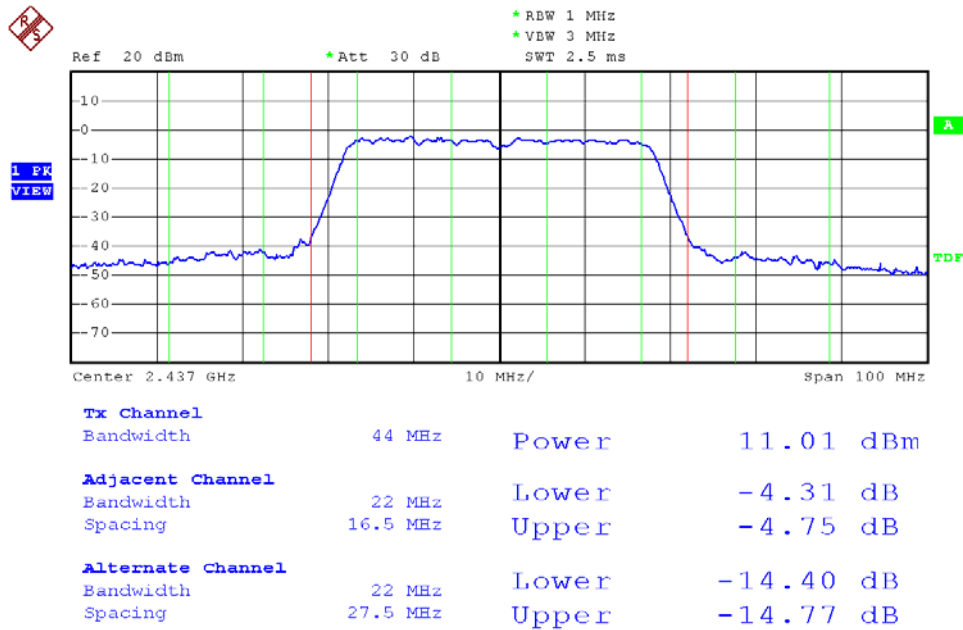

Modulation Standard: 802.11n HT40 (270Mbps), ANT L, Peak Power Output Channel: 09

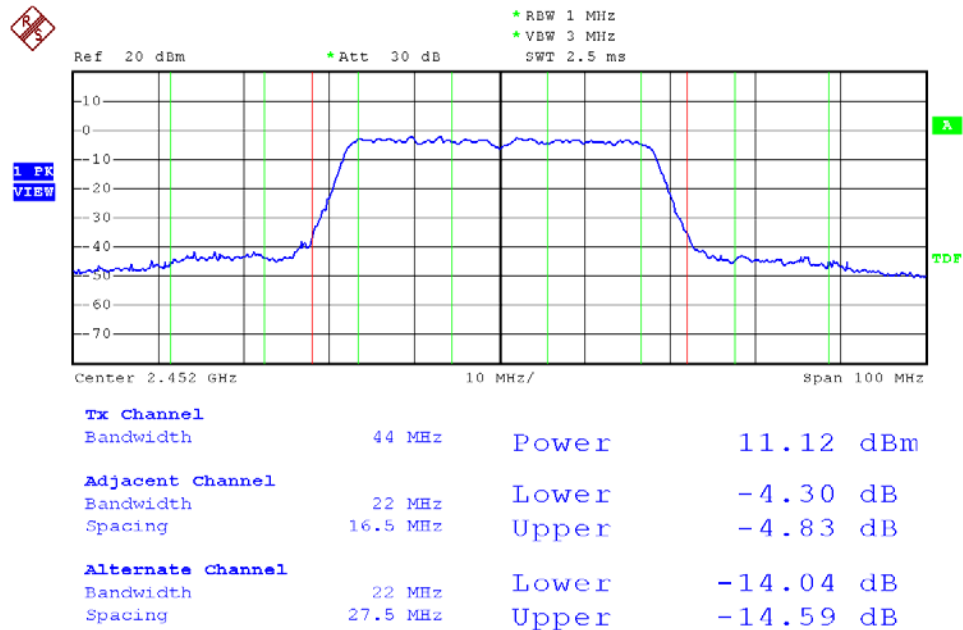



Modulation Standard: 802.11b (11Mbps), ANT R, Average Power Output Channel: 01

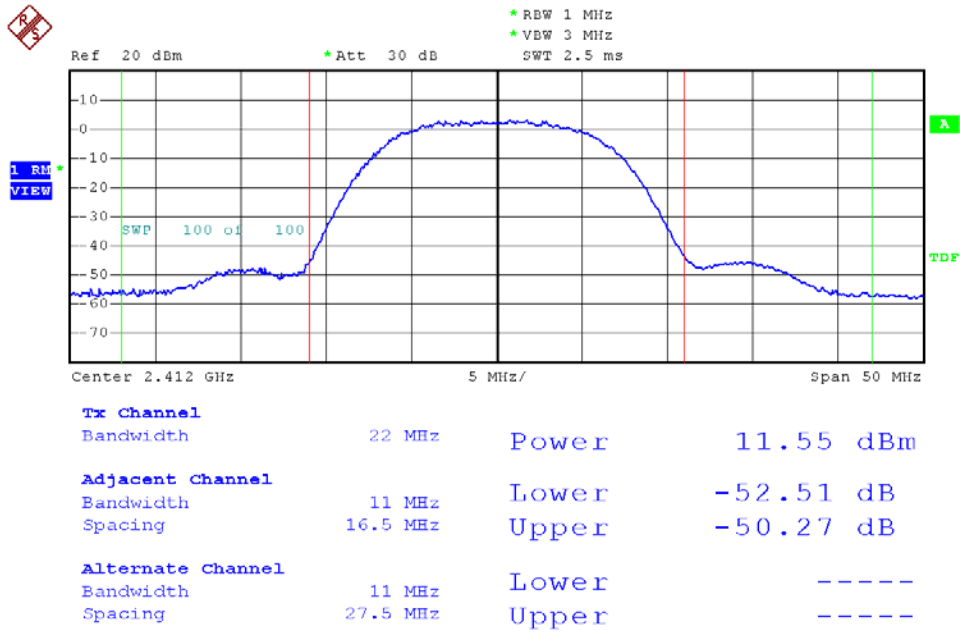

Modulation Standard: 802.11b (11Mbps), ANT R, Average Power Output Channel: 06

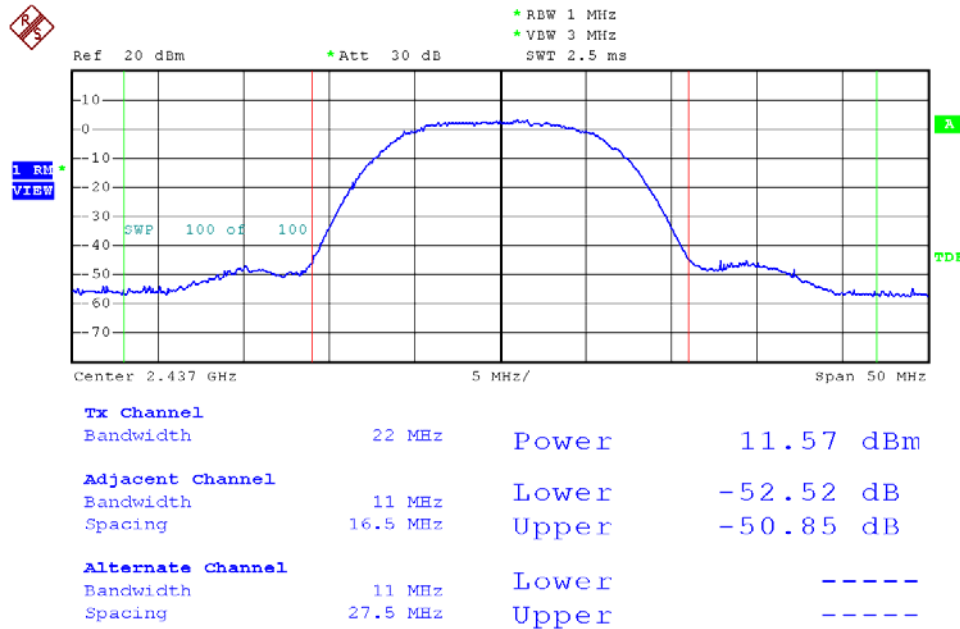



Modulation Standard: 802.11b (11Mbps), ANT R, Average Power Output Channel: 11

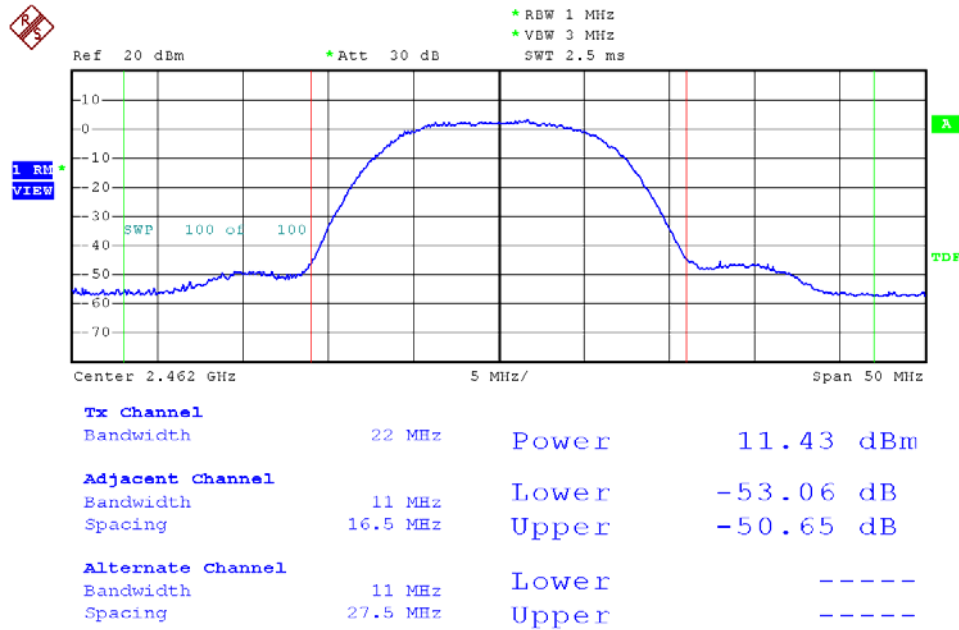

Modulation Standard: 802.11g (54Mbps), ANT R, Average Power Output Channel: 01

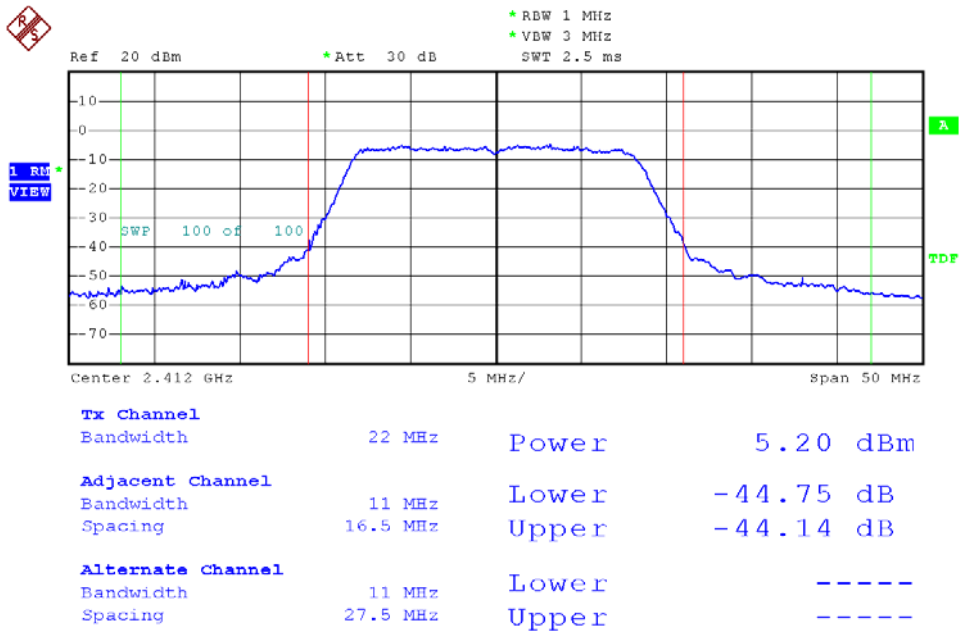



Modulation Standard: 802.11g (54Mbps), ANT R, Average Power Output Channel: 06

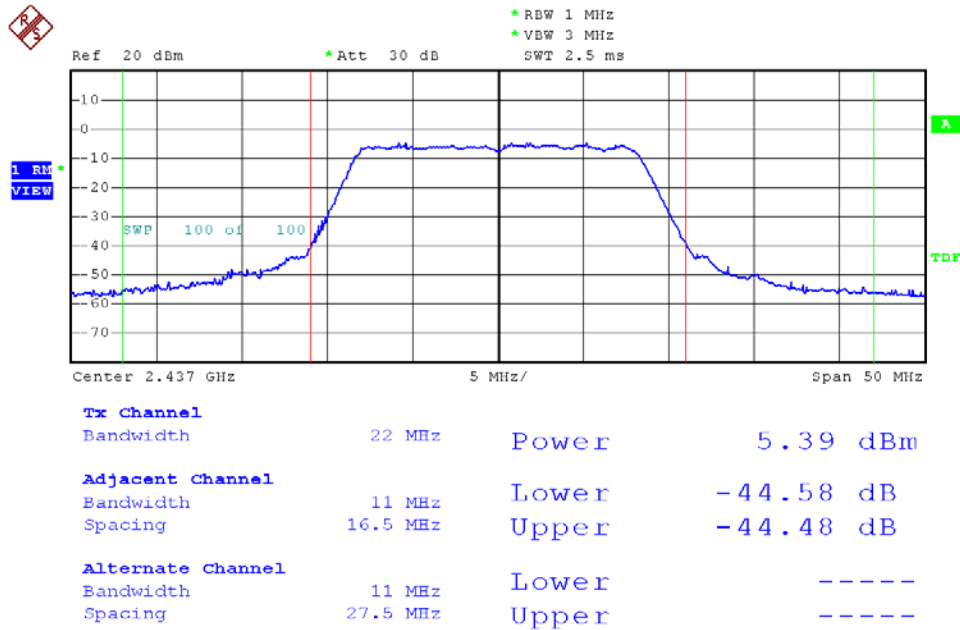

Modulation Standard: 802.11g (6Mbps), ANT R, Average Power Output Channel: 11

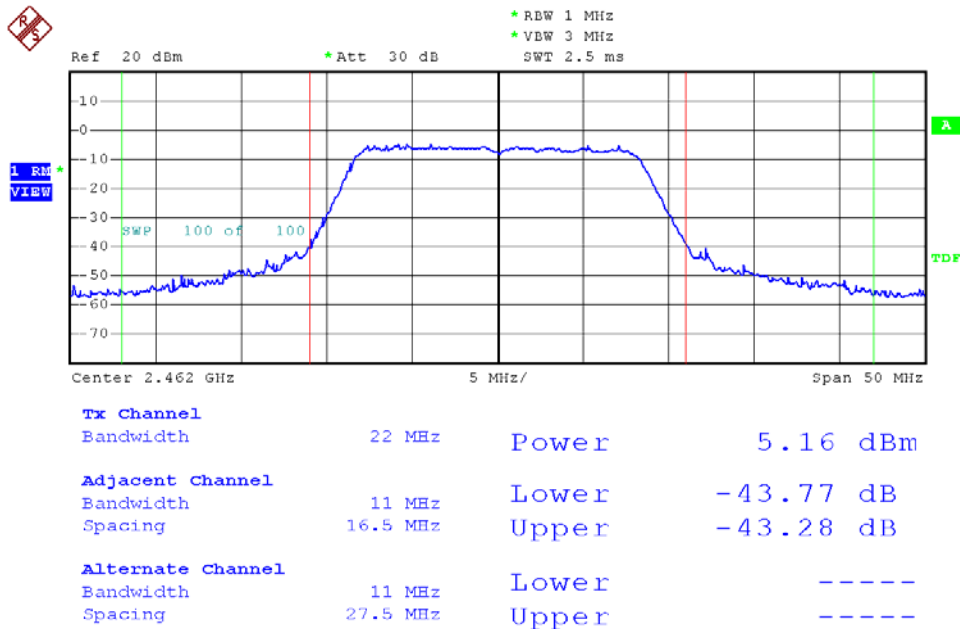



Modulation Standard: 802.11n HT20 (130Mbps), ANT R, Average Power Output Channel: 01

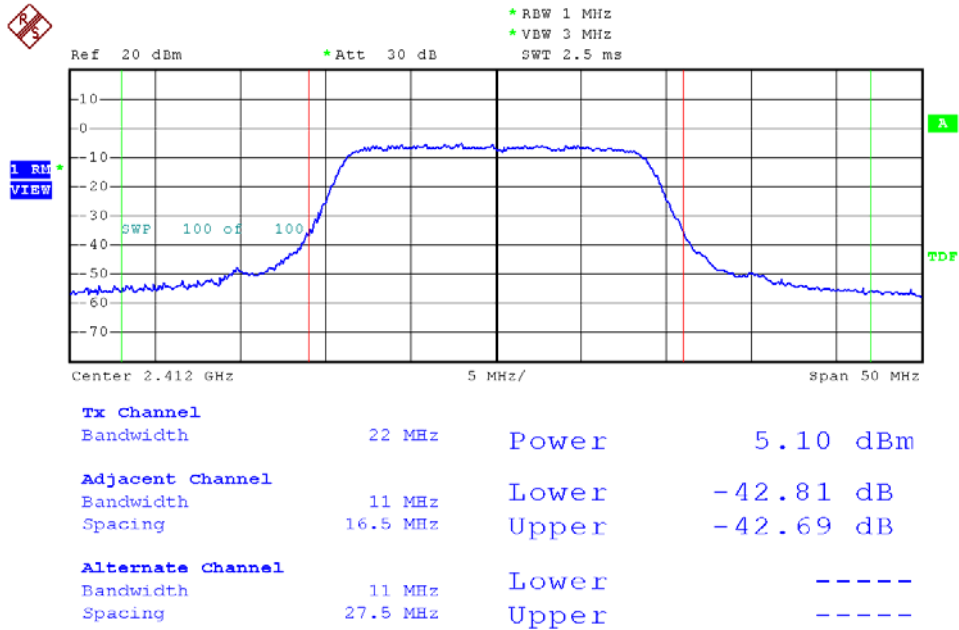

Modulation Standard: 802.11n HT20 (130Mbps), ANT R, Average Power Output Channel: 06

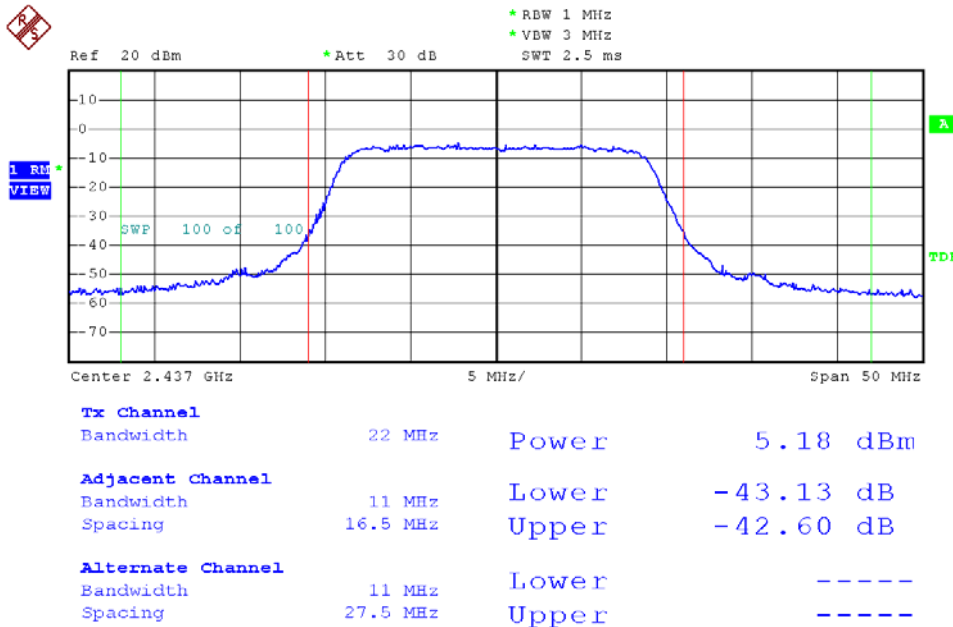



Modulation Standard: 802.11n HT20 (130Mbps), ANT R, Average Power Output Channel: 11

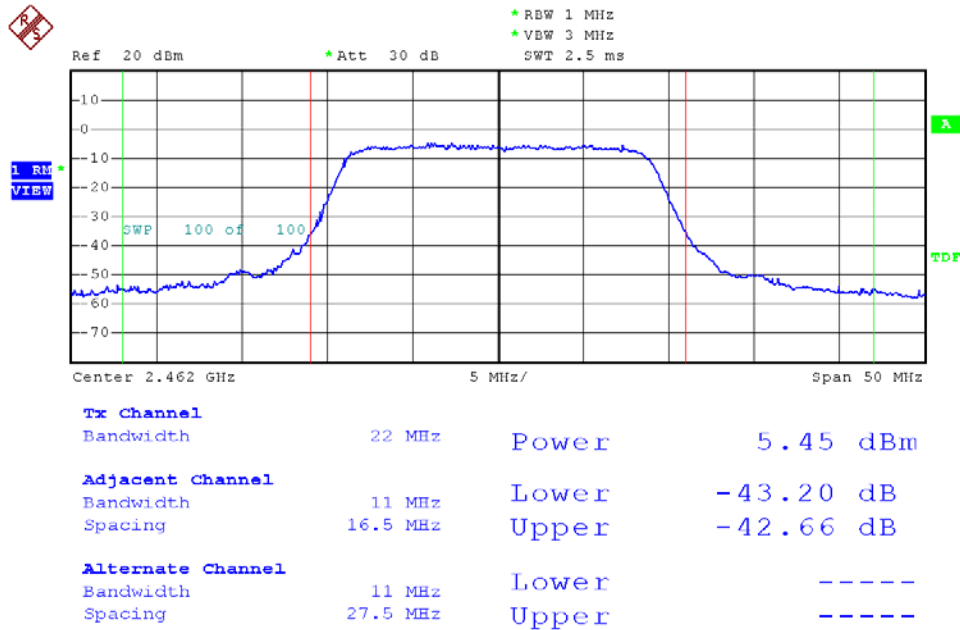

Modulation Standard: 802.11n HT40 (270Mbps), ANT R, Average Power Output Channel: 03

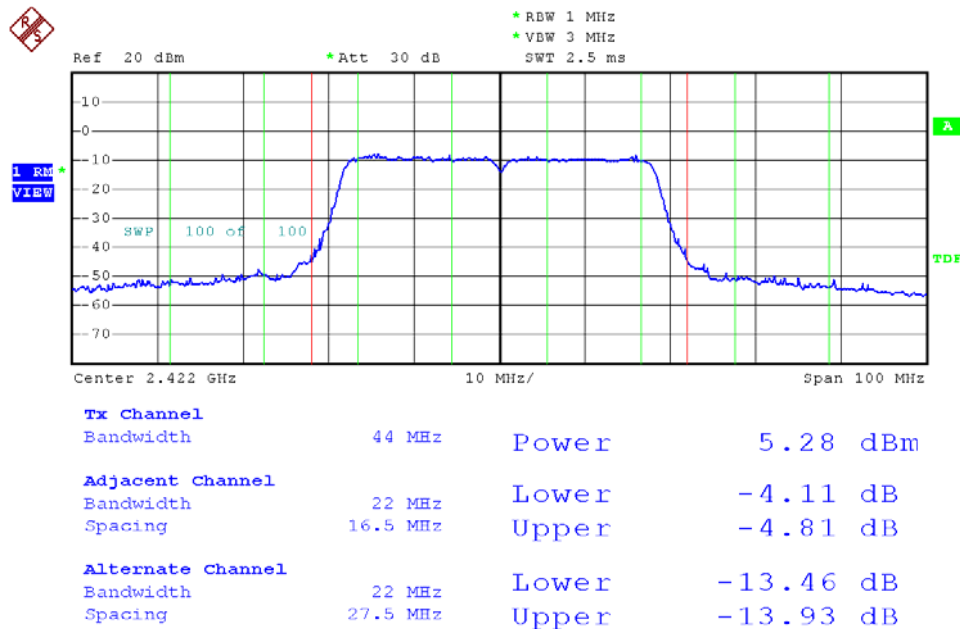



Modulation Standard: 802.11n HT40 (270Mbps), ANT R, Average Power Output Channel: 06

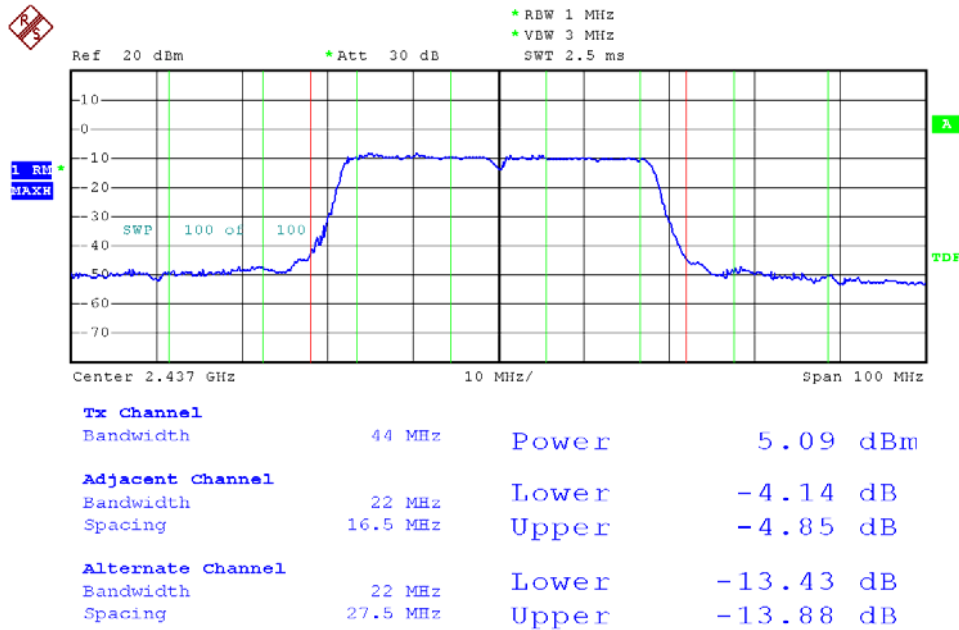

Modulation Standard: 802.11n HT40 (270Mbps), ANT R, Average Power Output Channel: 09

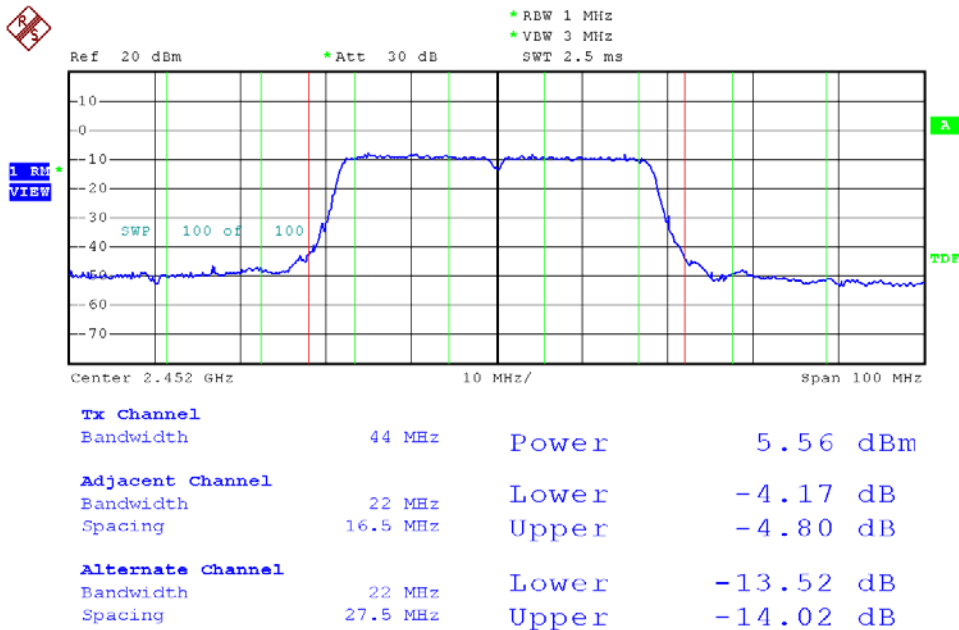



Modulation Standard: 802.11b (11Mbps), ANT L, Average Power Output Channel: 01

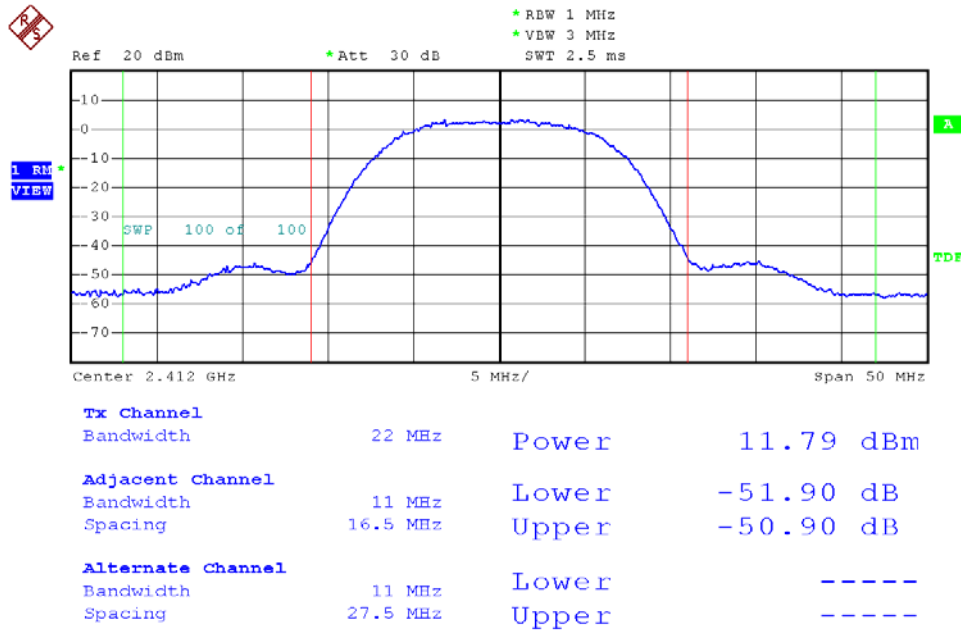

Modulation Standard: 802.11b (11Mbps), ANT L, Average Power Output Channel: 06

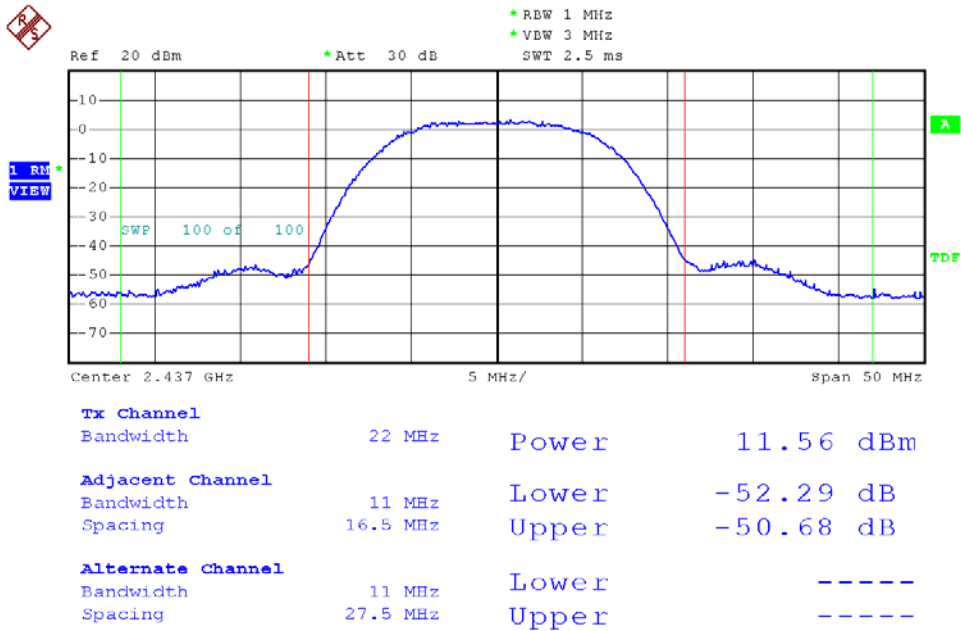



Modulation Standard: 802.11b (11Mbps), ANT L, Average Power Output Channel: 11

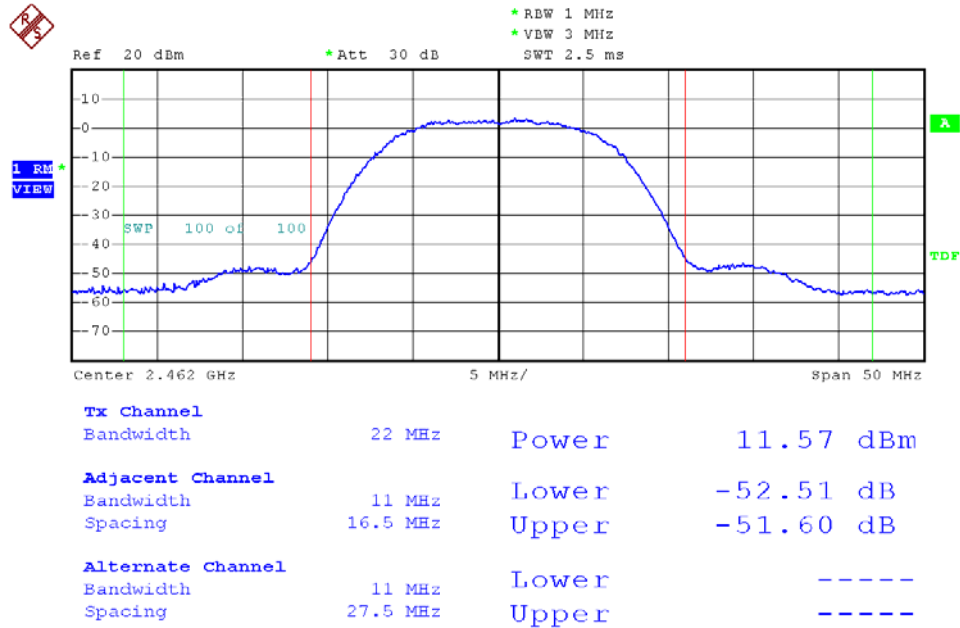

Modulation Standard: 802.11g (54Mbps), ANT L, Average Power Output Channel: 01

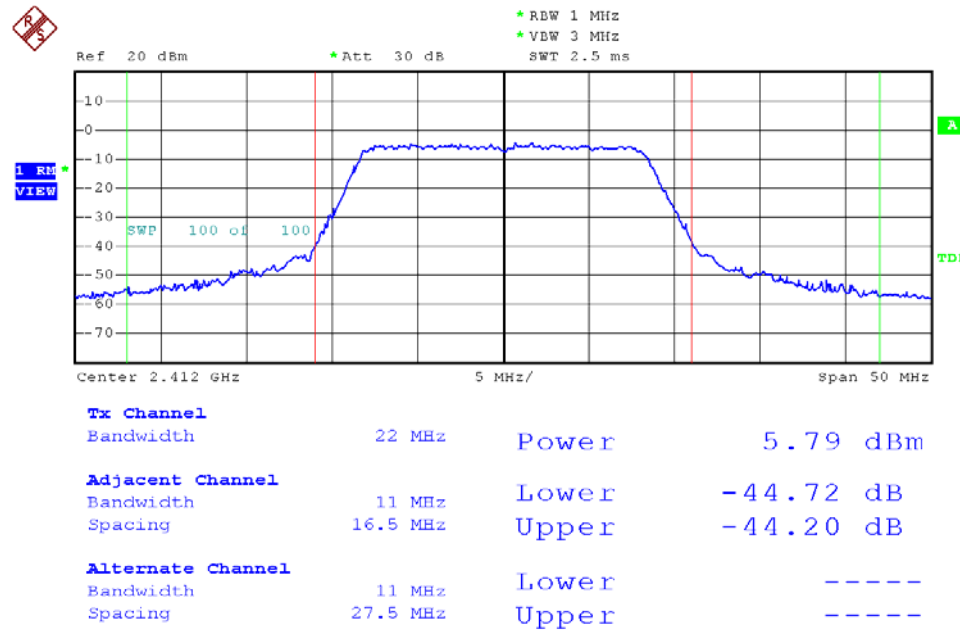



Modulation Standard: 802.11g (54Mbps), ANT L, Average Power Output Channel: 06

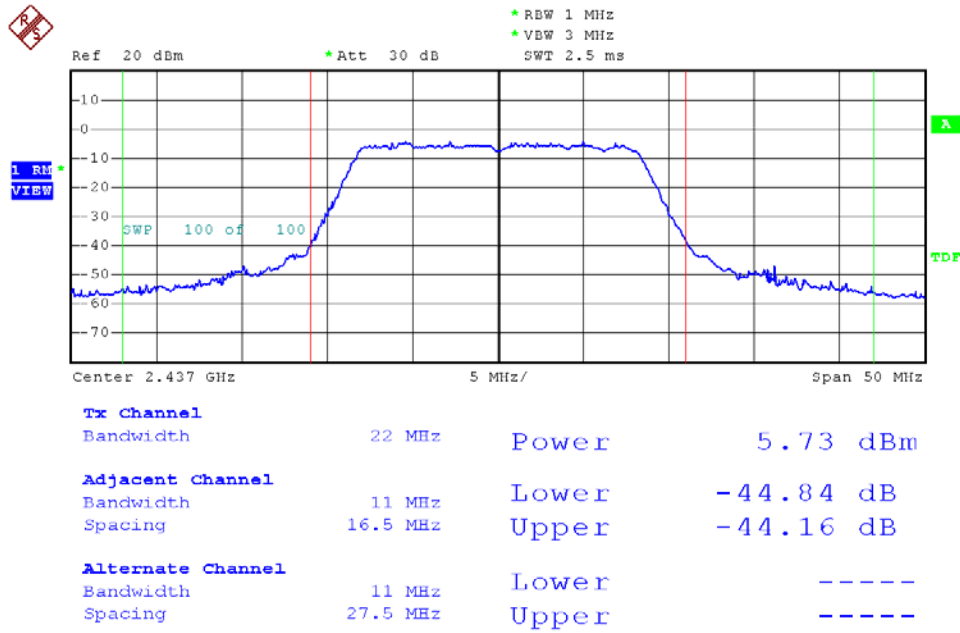

Modulation Standard: 802.11g (54Mbps), ANT L, Average Power Output Channel: 11

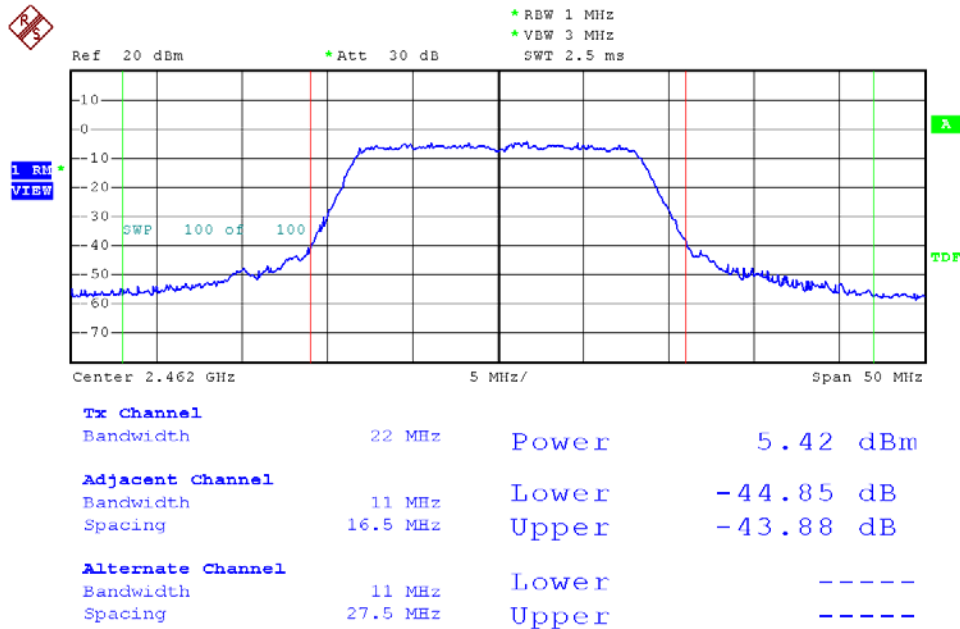



Modulation Standard: 802.11n HT20 (130Mbps), ANT L, Average Power Output Channel: 01

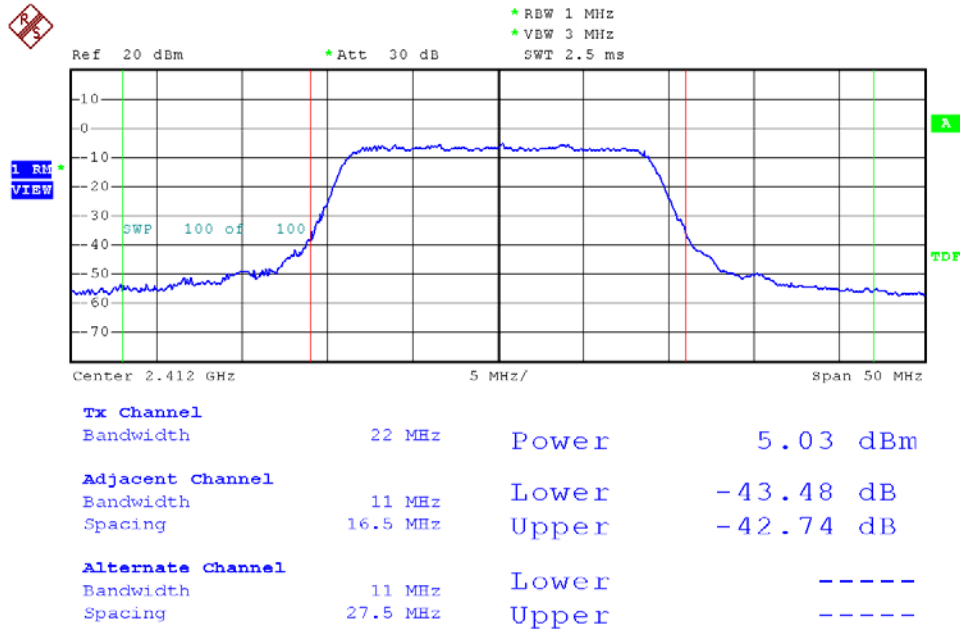

Modulation Standard: 802.11n HT20 (130Mbps), ANT L, Average Power Output Channel: 06

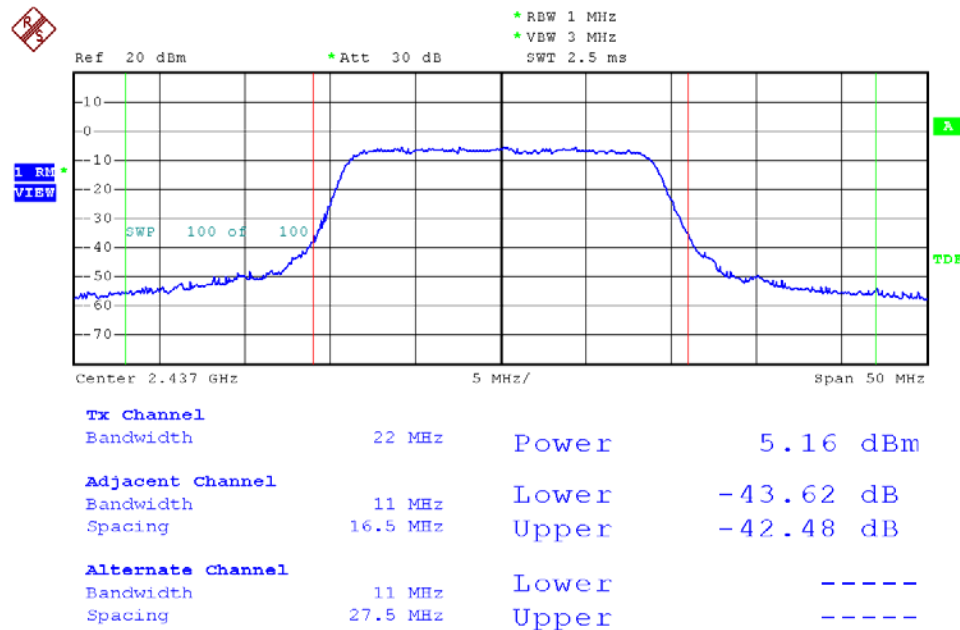



Modulation Standard: 802.11n HT20 (130Mbps), ANT L, Average Power Output Channel: 11

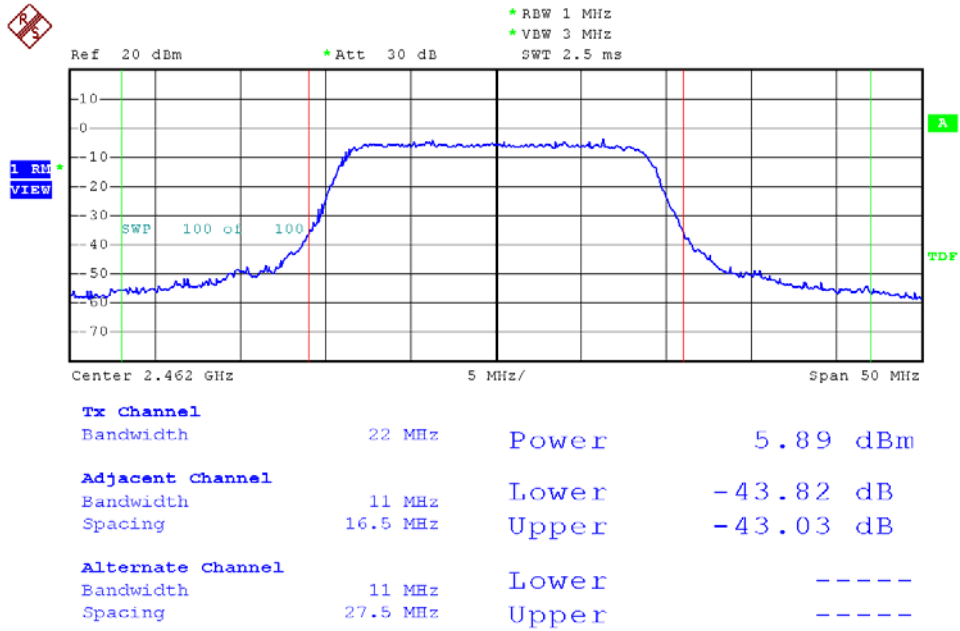

Modulation Standard: 802.11n HT40 (270Mbps), ANT L, Average Power Output Channel: 03

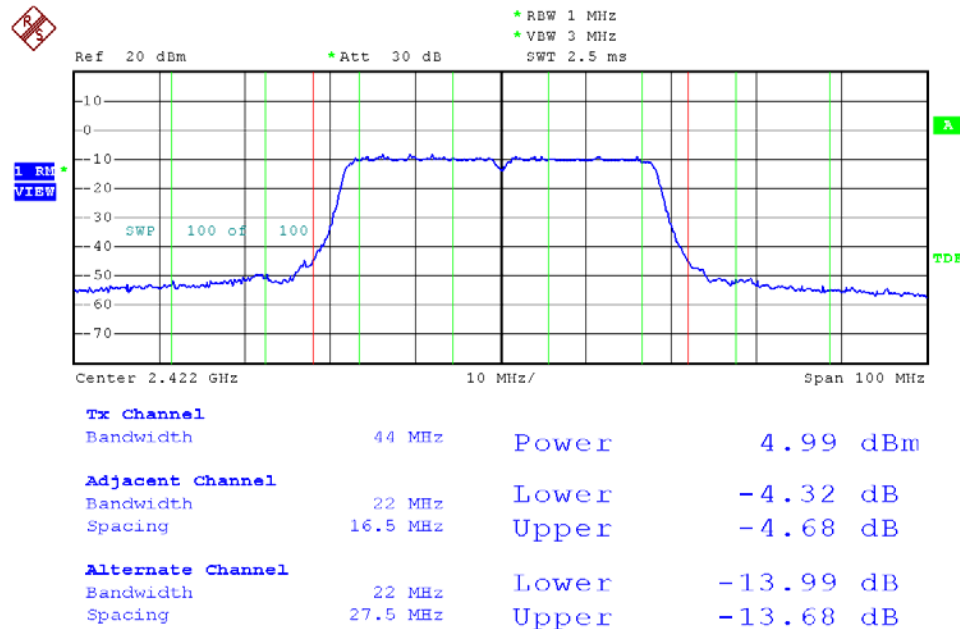



Modulation Standard: 802.11n HT40 (270Mbps), ANT L, Average Power Output Channel: 06

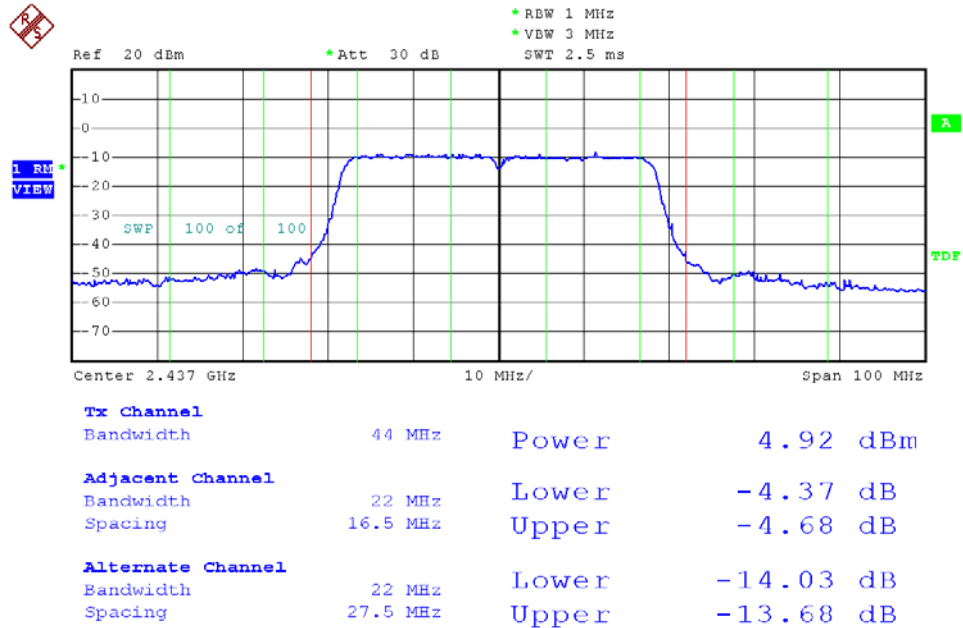

Modulation Standard: 802.11n HT40 (270Mbps), ANT L, Average Power Output Channel: 09

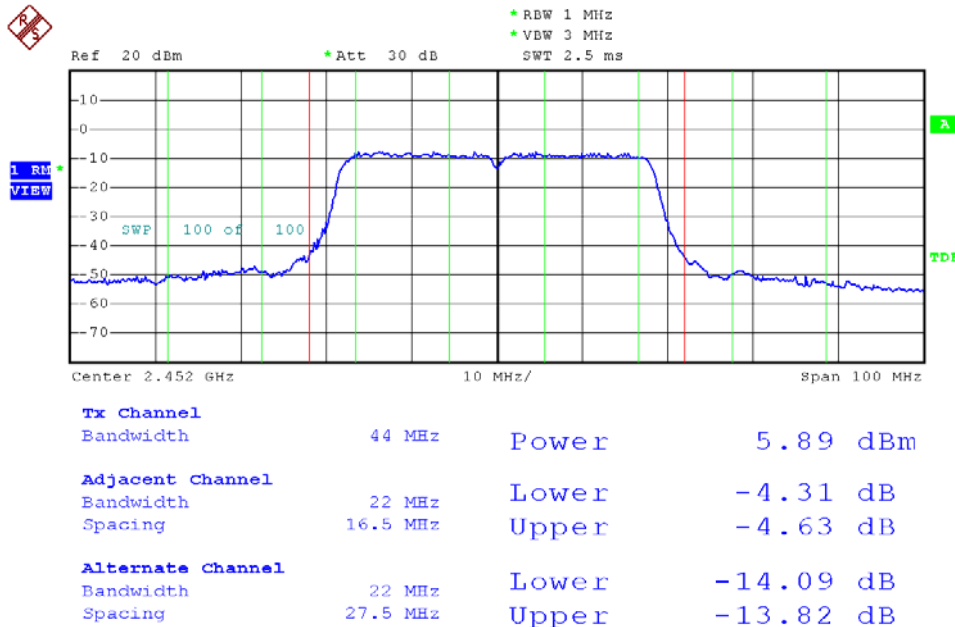



8. Power Spectral Density

8.1 Test Limit

The Maximum of Power Spectral Density Measurement is 8dBm.

8.2 Test Procedures

- a. The transmitter output was connected to spectrum analyzer.
- b. The spectrum analyzer's resolution bandwidth were set at 100KHz RBW and 300KHz VBW as that of the fundamental frequency. Set the sweep time=auto couple.
- c. Scale the observed power level to an equivalent value in 3 kHz by adjusting the measured power by a bandwidth correction factor (BWCF) where $BWCF = 10 \log(3 \text{ kHz}/100) = -15.2 \text{ dB}$.
- d. The power spectral density was measured and recorded.

8.3 Test Setup Layout

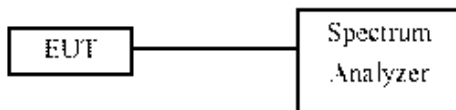

8.4 Measurement Equipment

Instrument/Ancillary	Manufacturer	Model No.	Serial No.	Calibration Date	Valid Date
Spectrum Analyzer	R&S	FSP40	100219	2011/11/24	2012/11/23

8.5 Test Result and Data

Test Date: Aug. 07, 2012

Temperature: 25°C

Atmospheric pressure: 1020 hPa

Humidity: 65%

Modulation Standard	Channel	Frequency (MHz)	ANT R			ANT L		
			Measured Power Density (dBm)	BWCF (dB)	Maximum Power Density of 3 kHz Bandwidth (dBm)	Measured Power Density (dBm)	BWCF (dB)	Maximum Power Density of 3 kHz Bandwidth (dBm)
802.11b (11Mbps)	01	2412	-0.94	-15.2	-16.14	-0.90	-15.2	-16.10
	06	2437	-1.22	-15.2	-16.42	-1.03	-15.2	-16.23
	11	2462	-1.36	-15.2	-16.56	-0.74	-15.2	-15.94
802.11g (54Mbps)	01	2412	-9.20	-15.2	-24.40	-10.34	-15.2	-25.54
	06	2437	-9.38	-15.2	-24.58	-10.50	-15.2	-25.70
	11	2462	-9.08	-15.2	-24.28	-10.31	-15.2	-25.51



Modulation Standard	Channel	Frequency (MHz)	ANT R		
			Measured Power Density (dBm)	BWCF (dB)	Maximum Power Density of 3 kHz Bandwidth (dBm)
802.11n HT20 (130Mbps)	01	2412	-9.25	-15.2	-24.45
	06	2437	-10.32	-15.2	-25.52
	11	2462	-10.92	-15.2	-26.12
802.11n HT40 (270Mbps)	03	2422	-13.07	-15.2	-28.27
	06	2437	-14.54	-15.2	-29.74
	09	2452	-13.30	-15.2	-28.50

Modulation Standard	Channel	Frequency (MHz)	ANT L		
			Measured Power Density (dBm)	BWCF (dB)	Maximum Power Density of 3 kHz Bandwidth (dBm)
802.11n HT20 (130Mbps)	01	2412	-11.03	-15.2	-26.23
	06	2437	-10.15	-15.2	-25.35
	11	2462	-9.52	-15.2	-24.72
802.11n HT40 (270Mbps)	03	2422	-13.35	-15.2	-28.55
	06	2437	-13.11	-15.2	-28.31
	09	2452	-12.10	-15.2	-27.30

Modulation Standard	Channel	Frequency (MHz)	ANT R + L
			Maximum Power Density of 3 kHz Bandwidth (dBm)
802.11n HT20 (130Mbps)	01	2412	-22.24
	06	2437	-22.42
	11	2462	-22.35
802.11n HT40 (270Mbps)	03	2422	-25.40
	06	2437	-25.96
	09	2452	-24.85



Modulation Standard: 802.11b (11Mbps), ANT R
Channel: 01

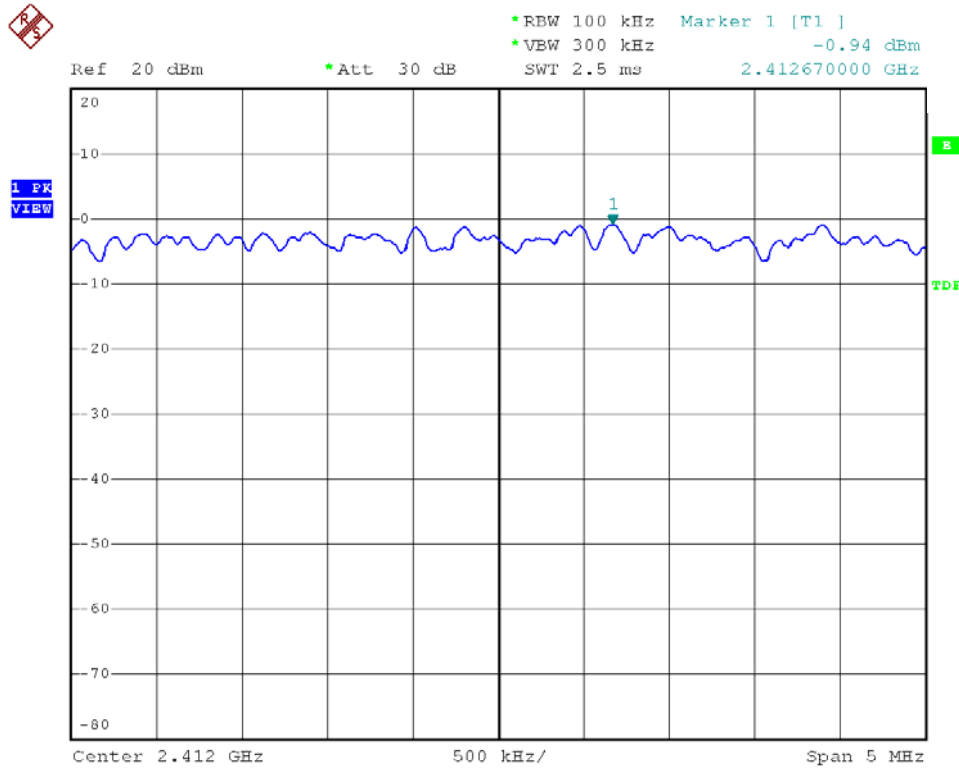

Modulation Standard: 802.11b (11Mbps), ANT R
Channel: 06

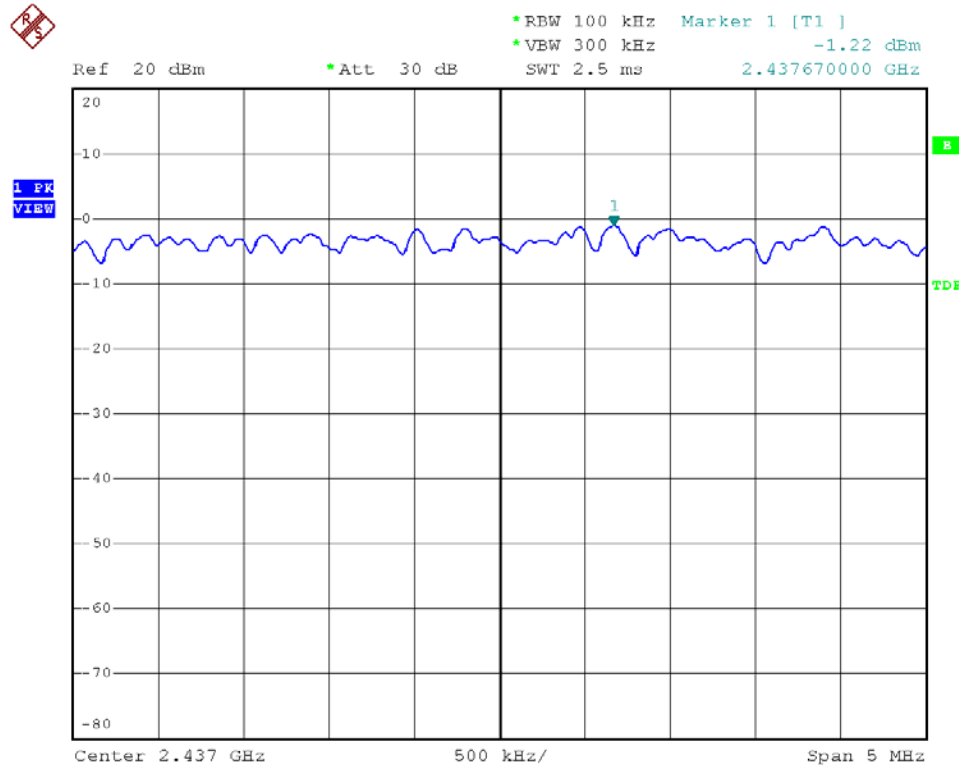



Modulation Standard: 802.11b (11Mbps), ANT R
Channel: 11

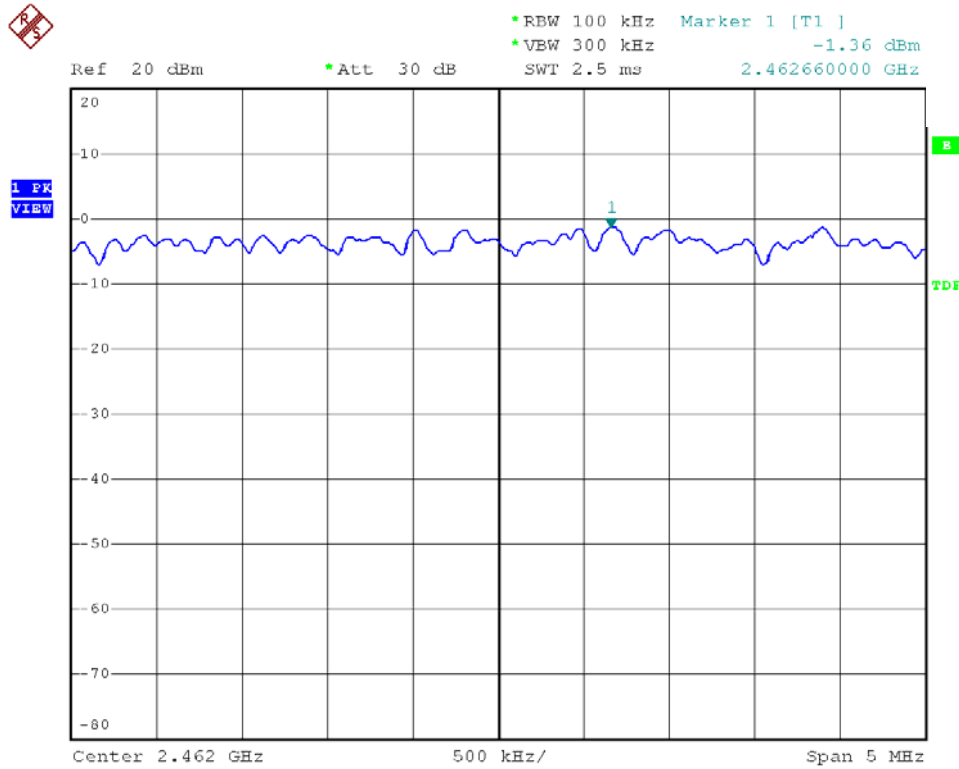

Modulation Standard: 802.11g (54Mbps), ANT R
Channel: 01

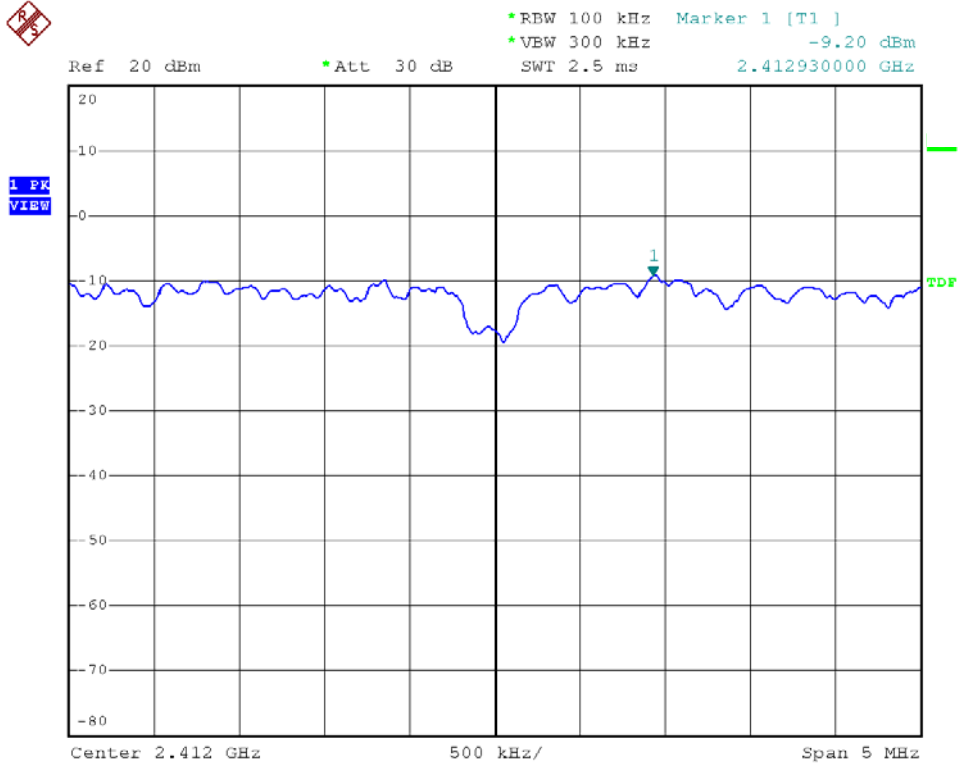



Modulation Standard: 802.11g (54Mbps), ANT R
Channel: 06

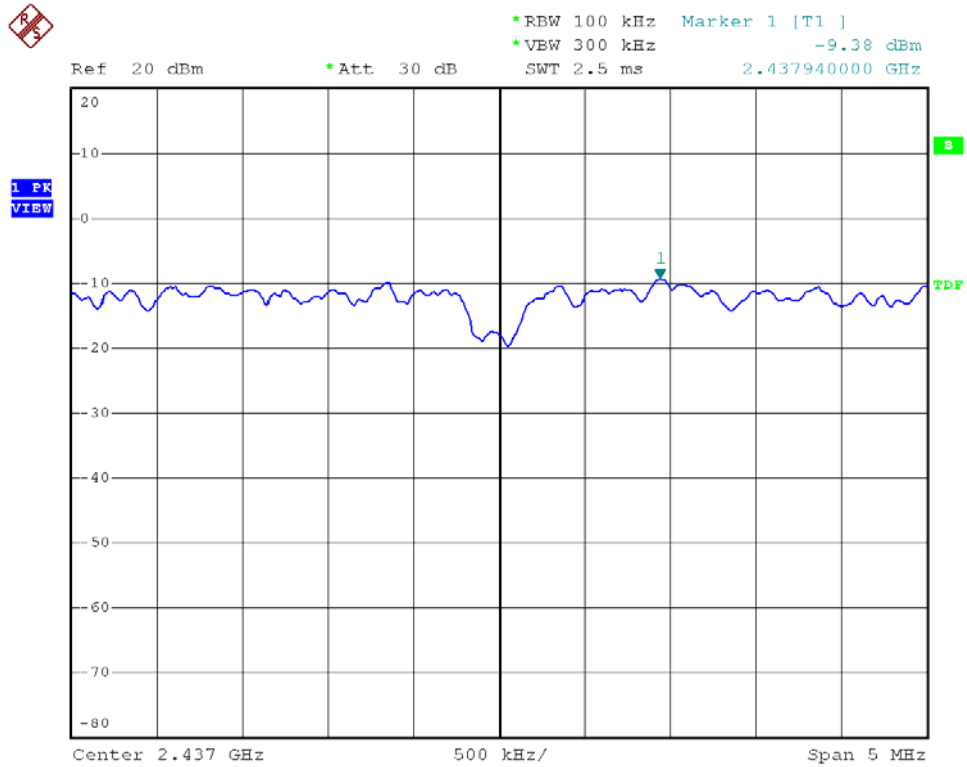

Modulation Standard: 802.11g (54Mbps), ANT R
Channel: 11

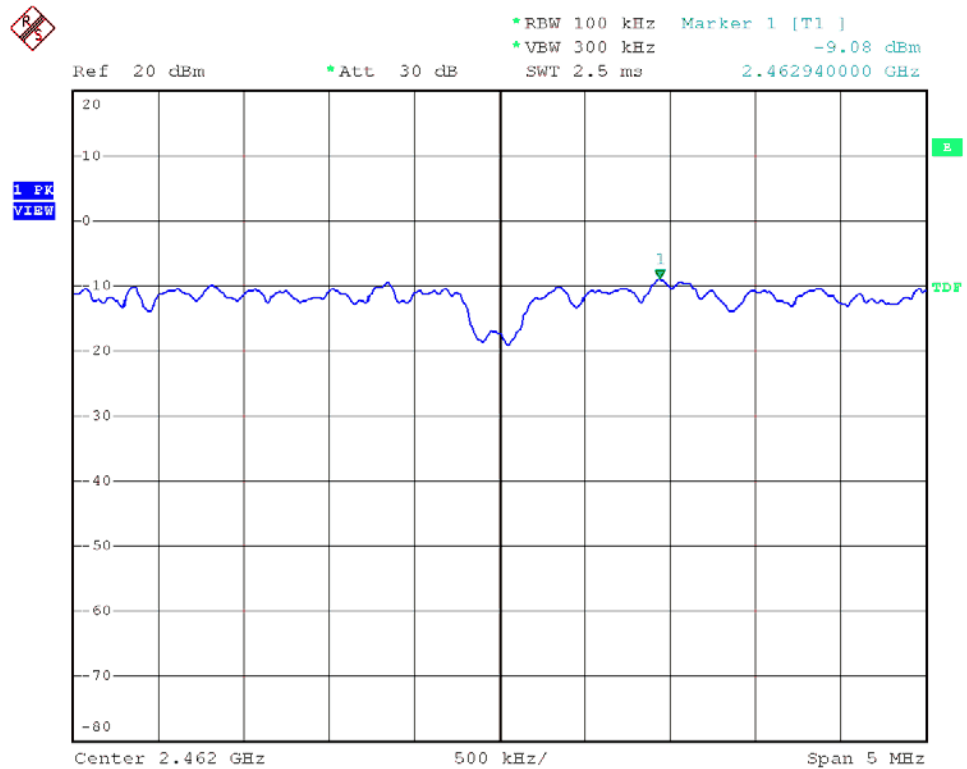



Modulation Standard: 802.11n HT20 (130Mbps), ANT R
Channel: 01

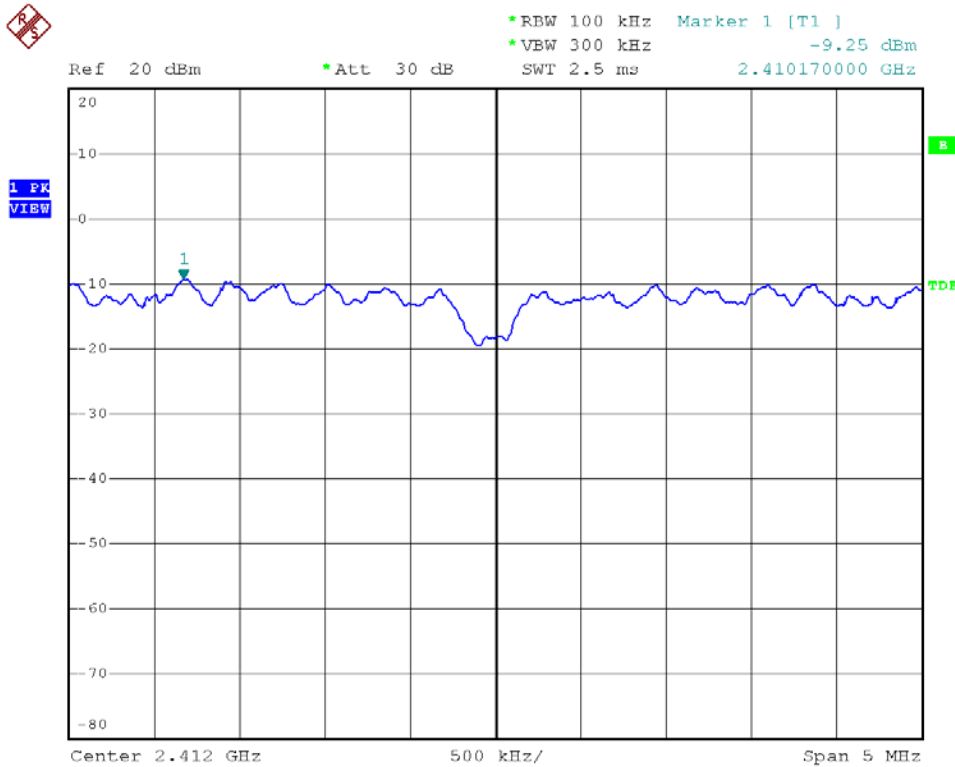

Modulation Standard: 802.11n HT20 (130Mbps), ANT R
Channel: 06

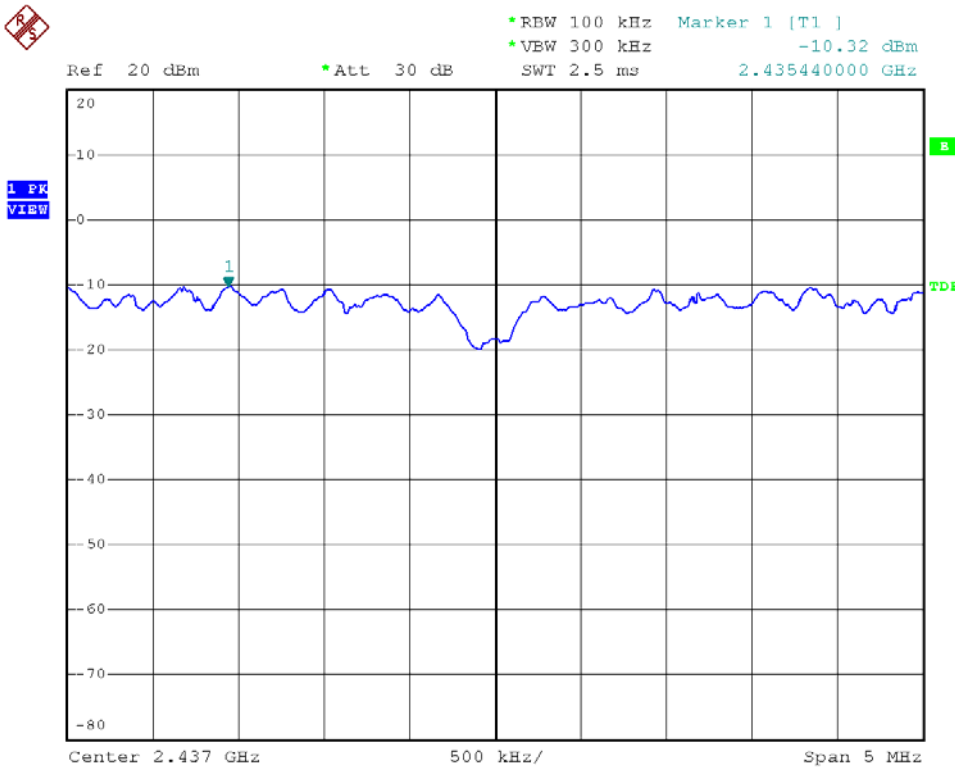



Modulation Standard: 802.11n HT20 (130Mbps), ANT R
Channel: 11

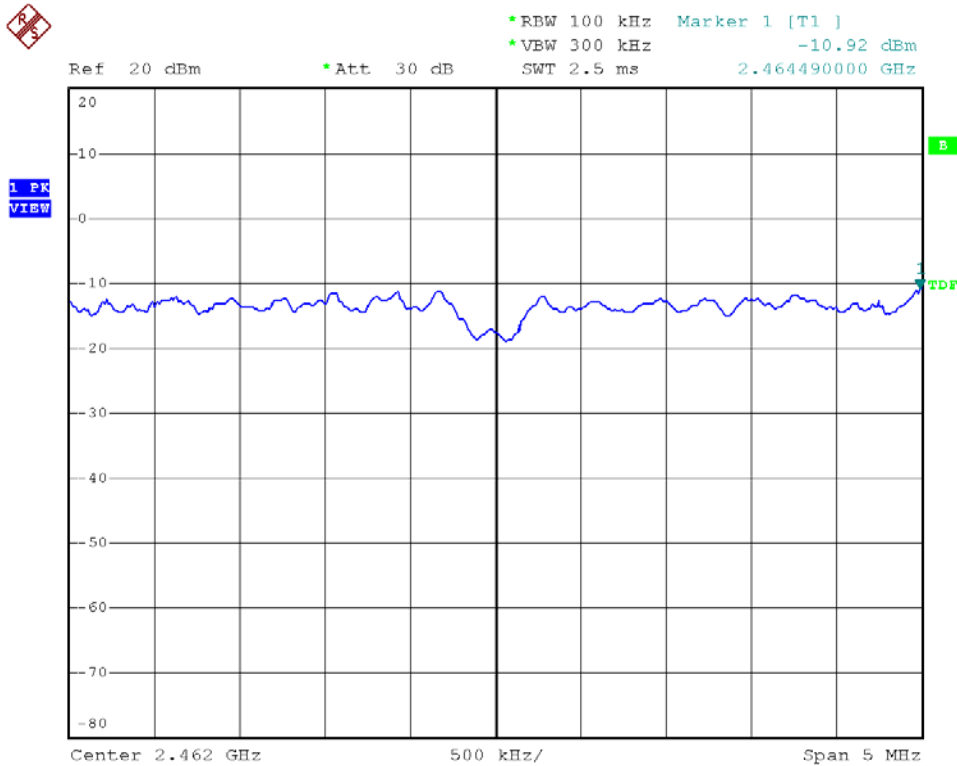

Modulation Standard: 802.11n HT40 (270Mbps), ANT R
Channel: 03

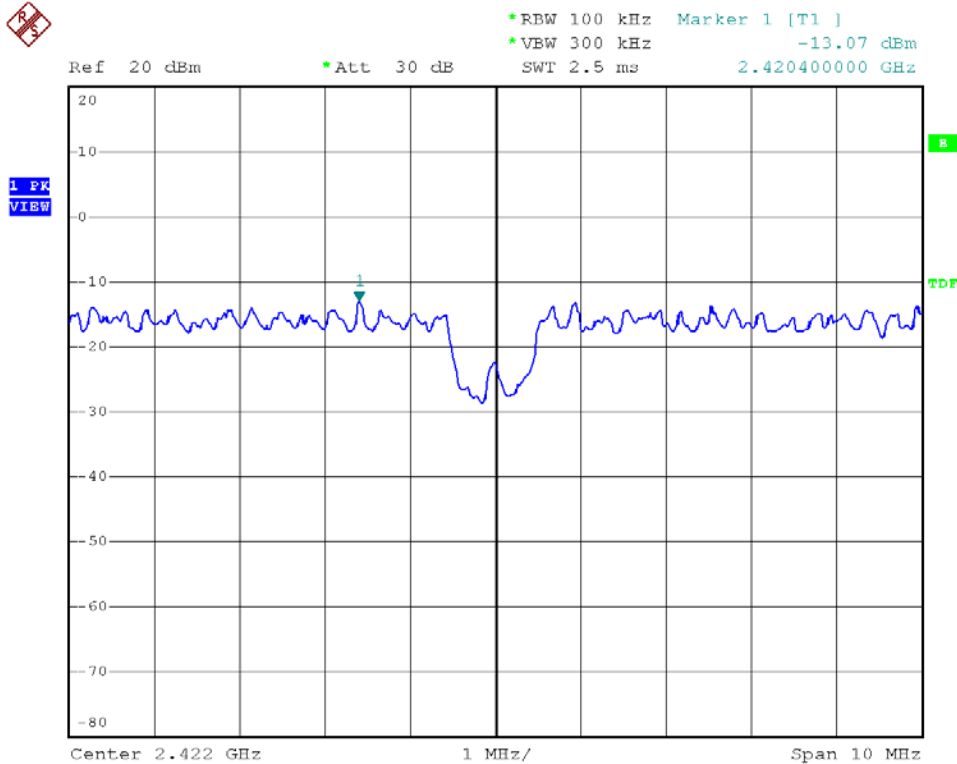



Modulation Standard: 802.11n HT40 (270Mbps), ANT R
Channel: 06

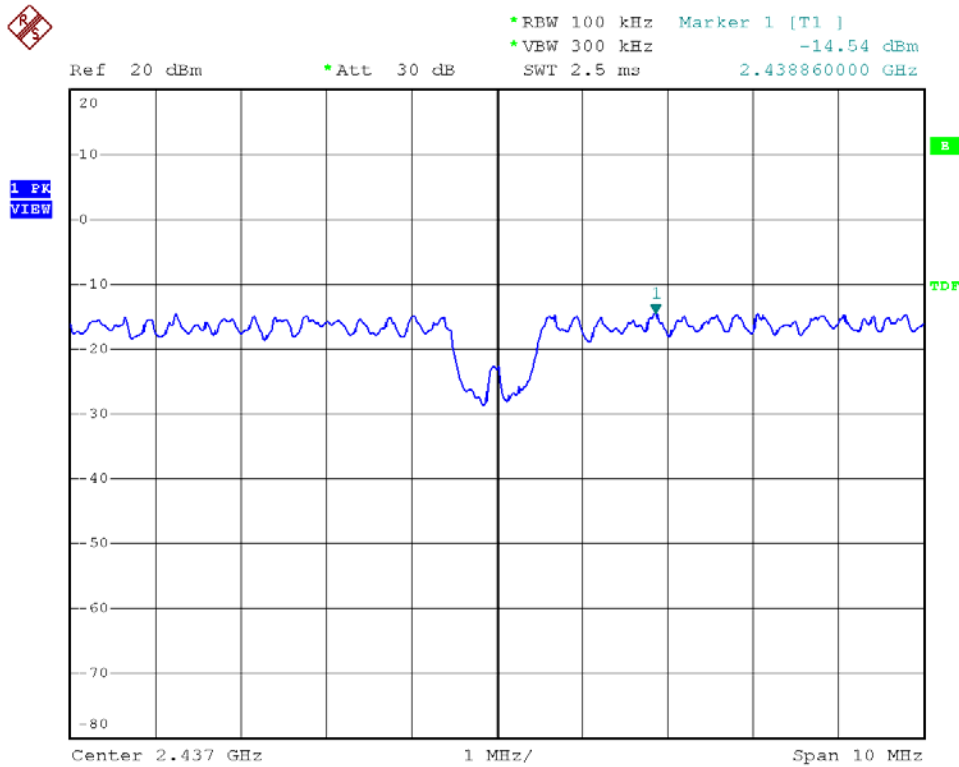

Modulation Standard: 802.11n HT40 (270Mbps), ANT R
Channel: 09

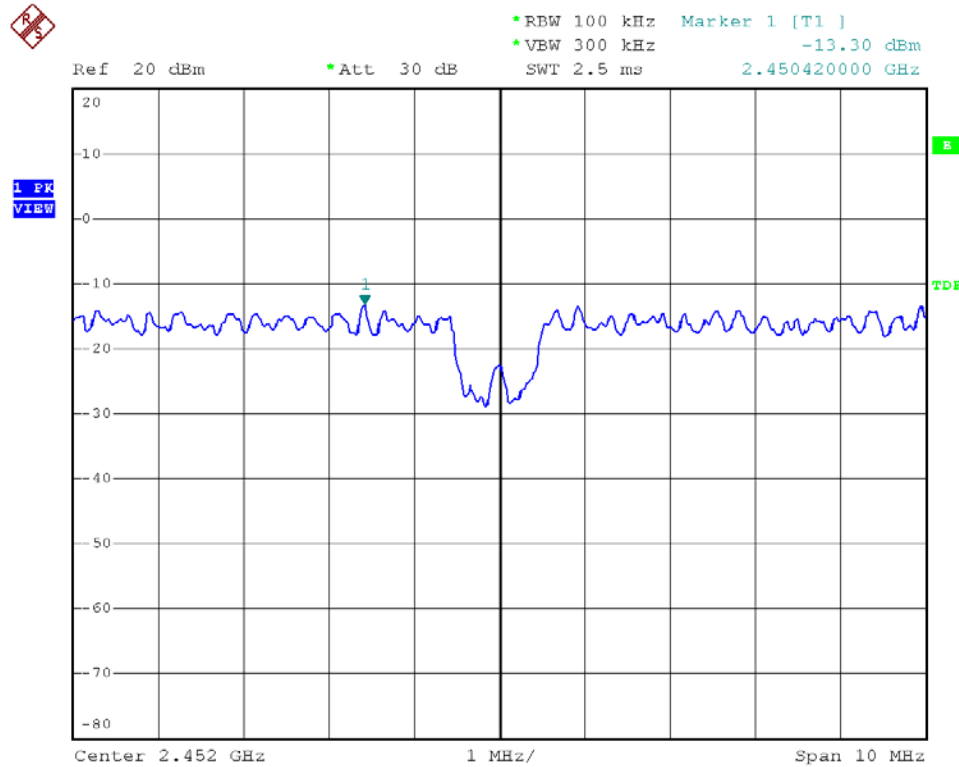



Modulation Standard: 802.11b (11Mbps), ANT L
Channel: 01

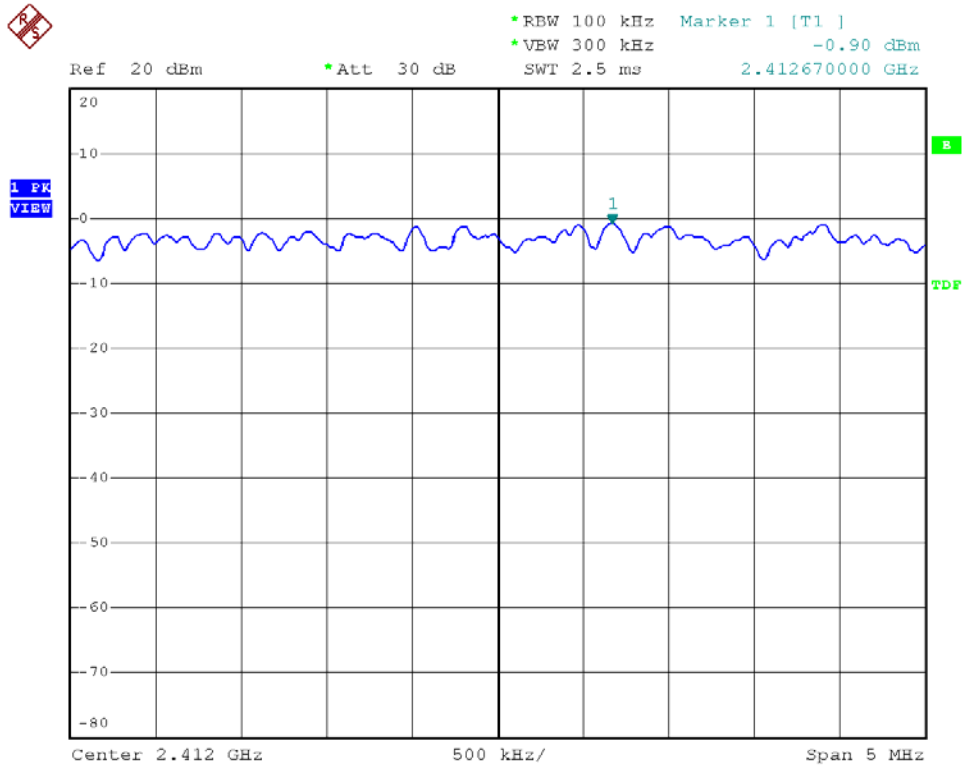

Modulation Standard: 802.11b (11Mbps), ANT L
Channel: 06

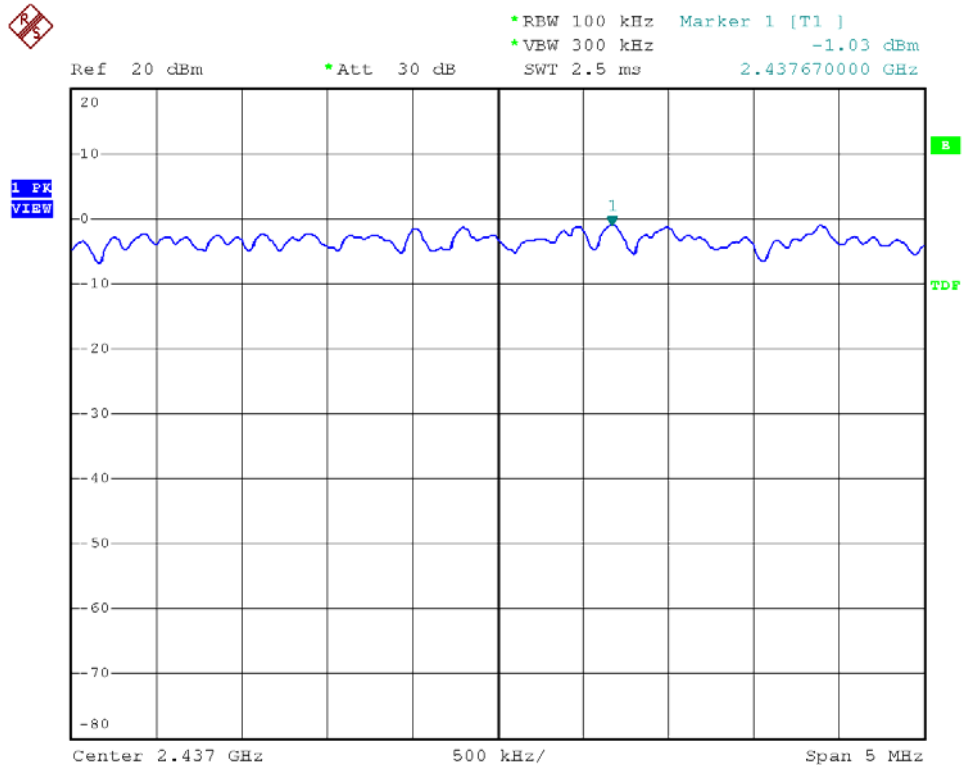



Modulation Standard: 802.11b (11Mbps), ANT L
Channel: 11

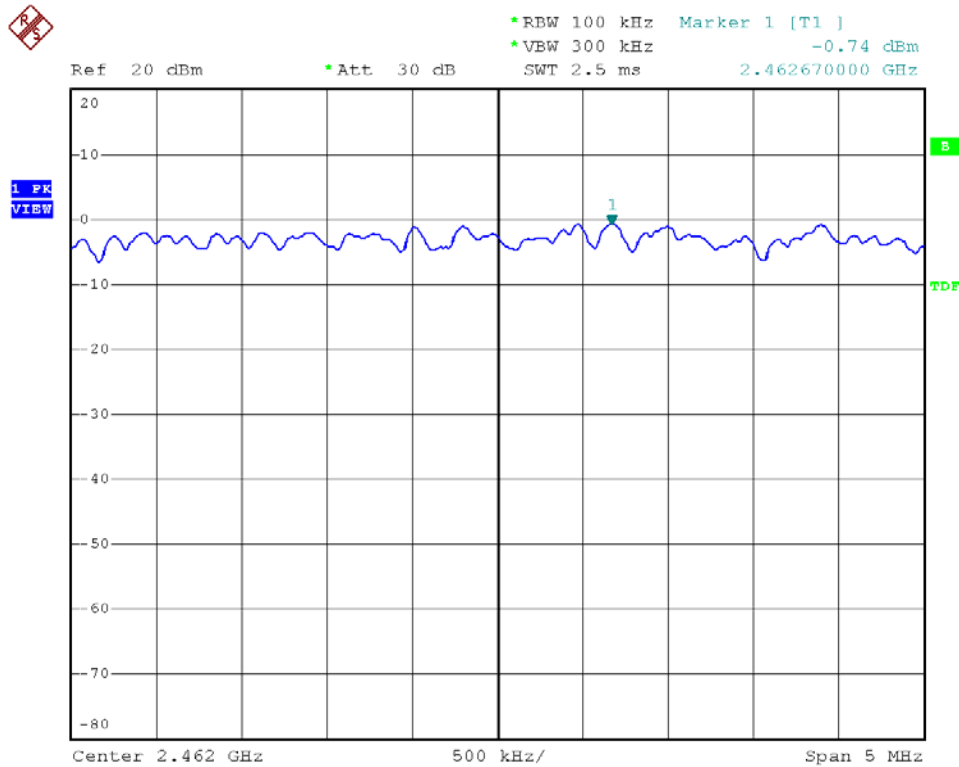

Modulation Standard: 802.11g (54Mbps), ANT L
Channel: 01

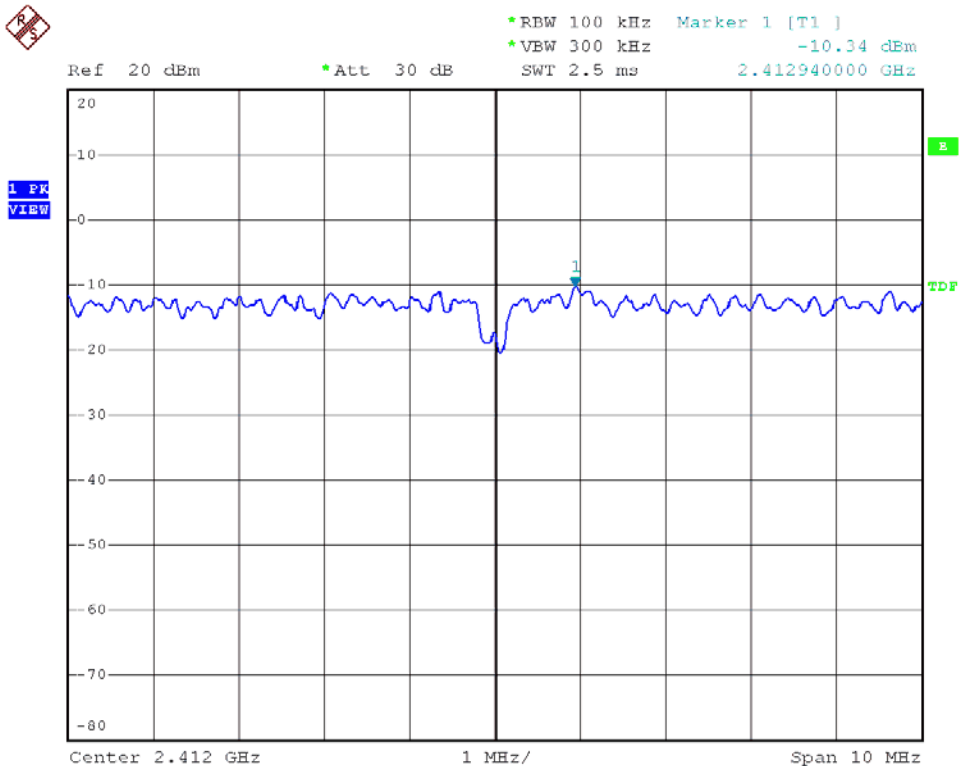



Modulation Standard: 802.11g (54Mbps), ANT L
Channel: 06

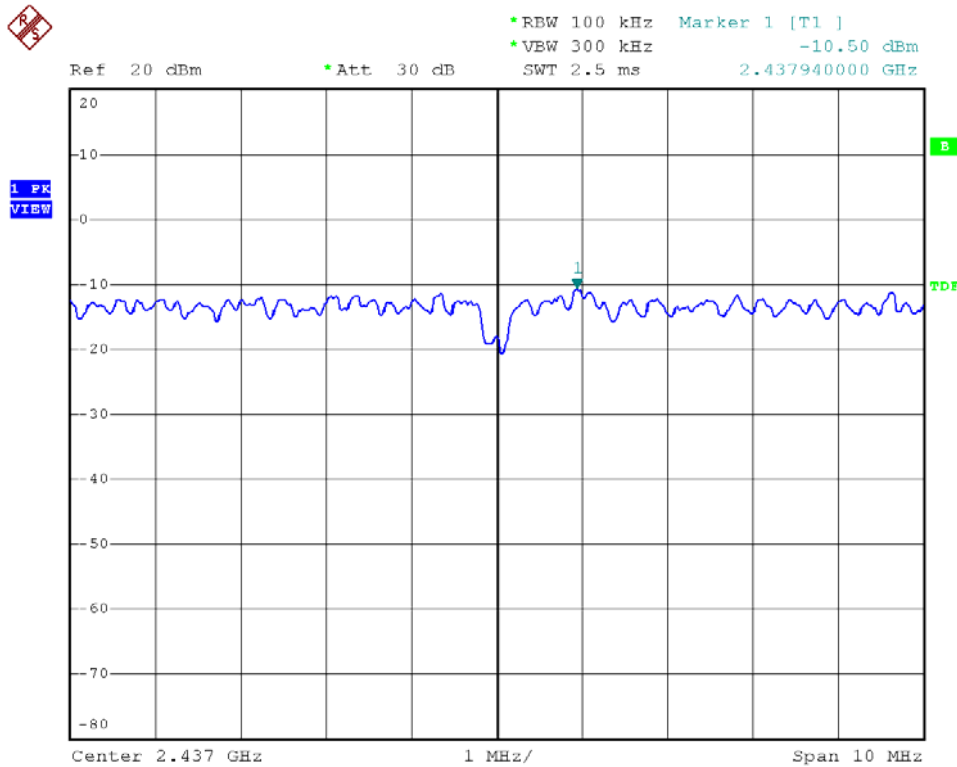

Modulation Standard: 802.11g (54Mbps), ANT L
Channel: 11

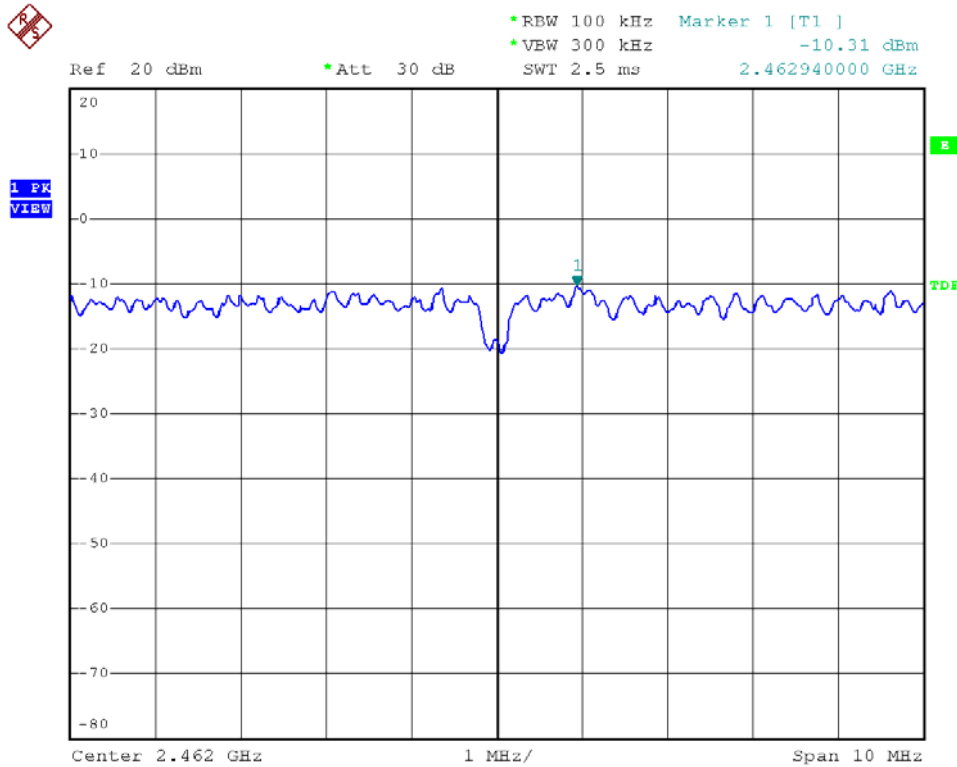



Modulation Standard: 802.11n HT20 (130Mbps), ANT L
Channel: 01

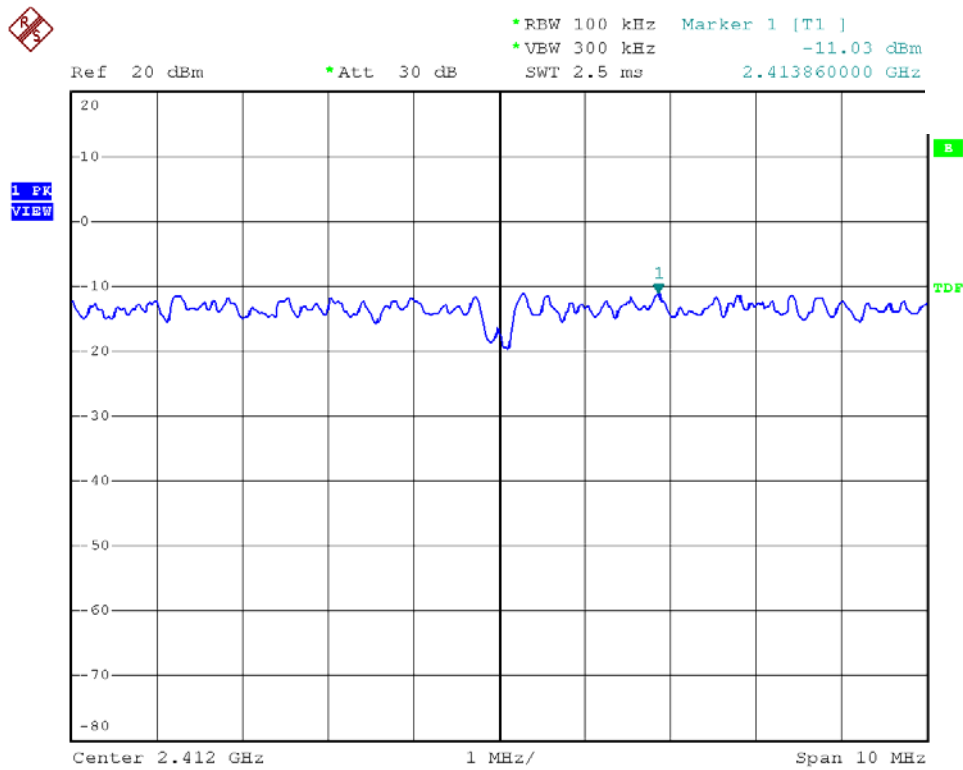

Modulation Standard: 802.11n HT20 (130Mbps), ANT L
Channel: 06

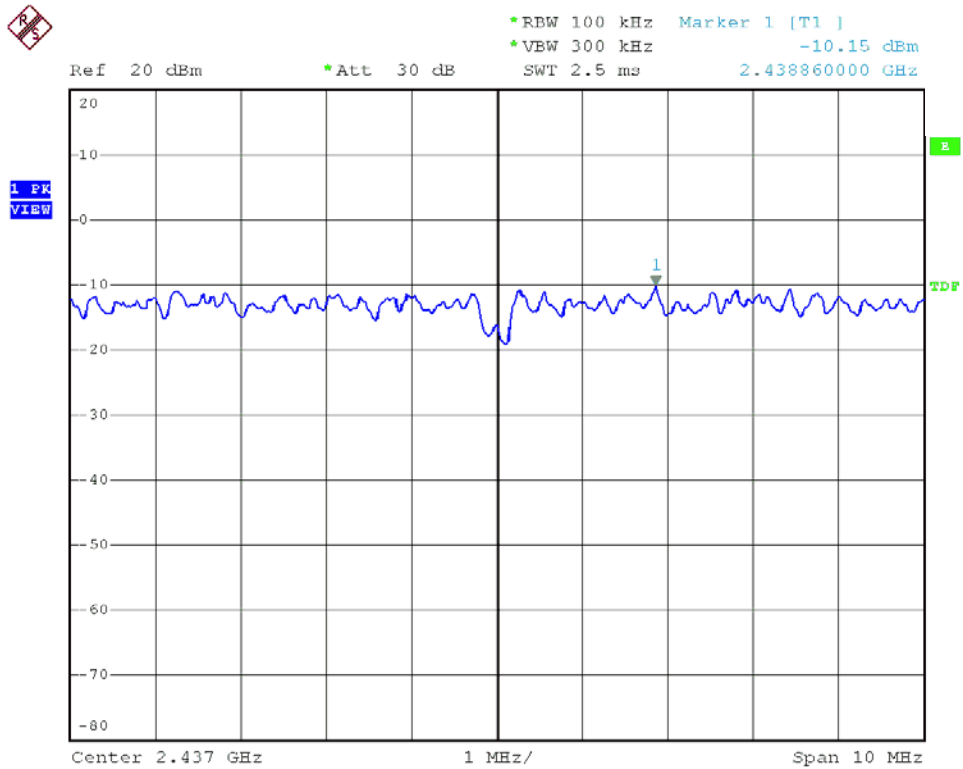



Modulation Standard: 802.11n HT20 (130Mbps), ANT L
Channel: 11

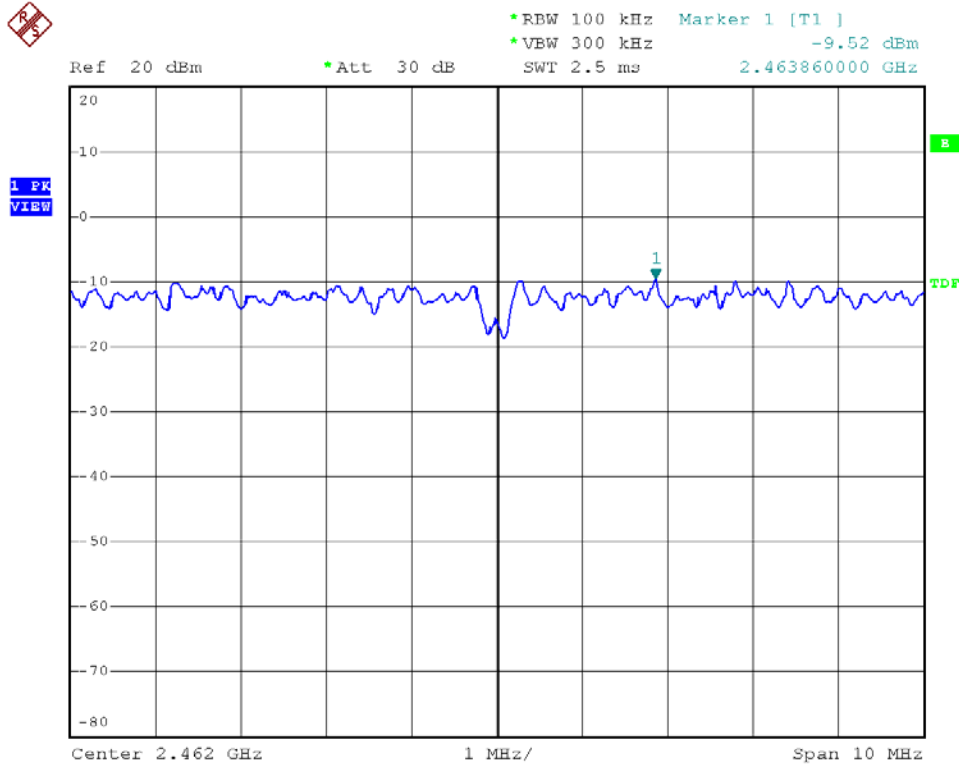

Modulation Standard: 802.11n HT40 (270Mbps), ANT L
Channel: 03

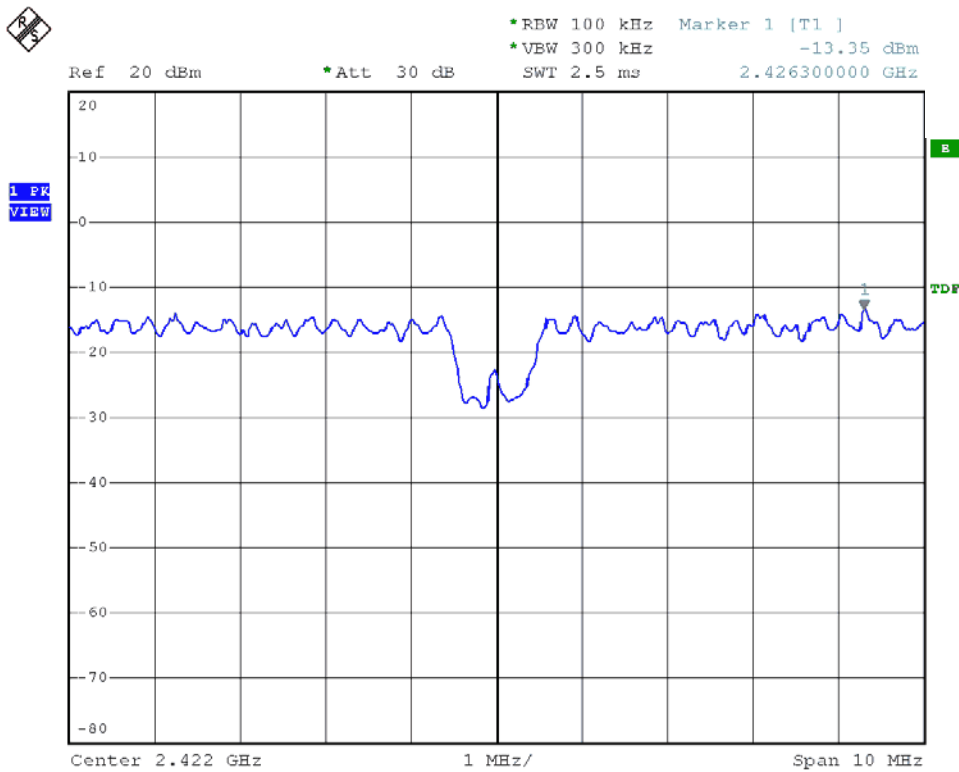



Modulation Standard: 802.11n HT40 (270Mbps), ANT L
Channel: 06

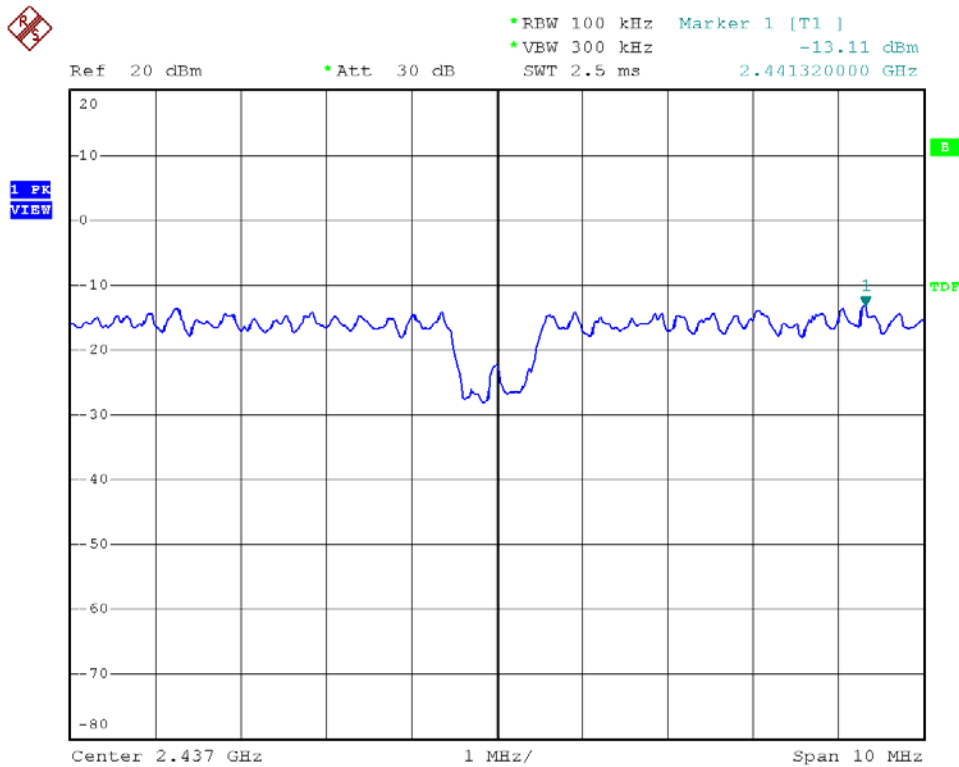

Modulation Standard: 802.11n HT40 (270Mbps), ANT L
Channel: 09

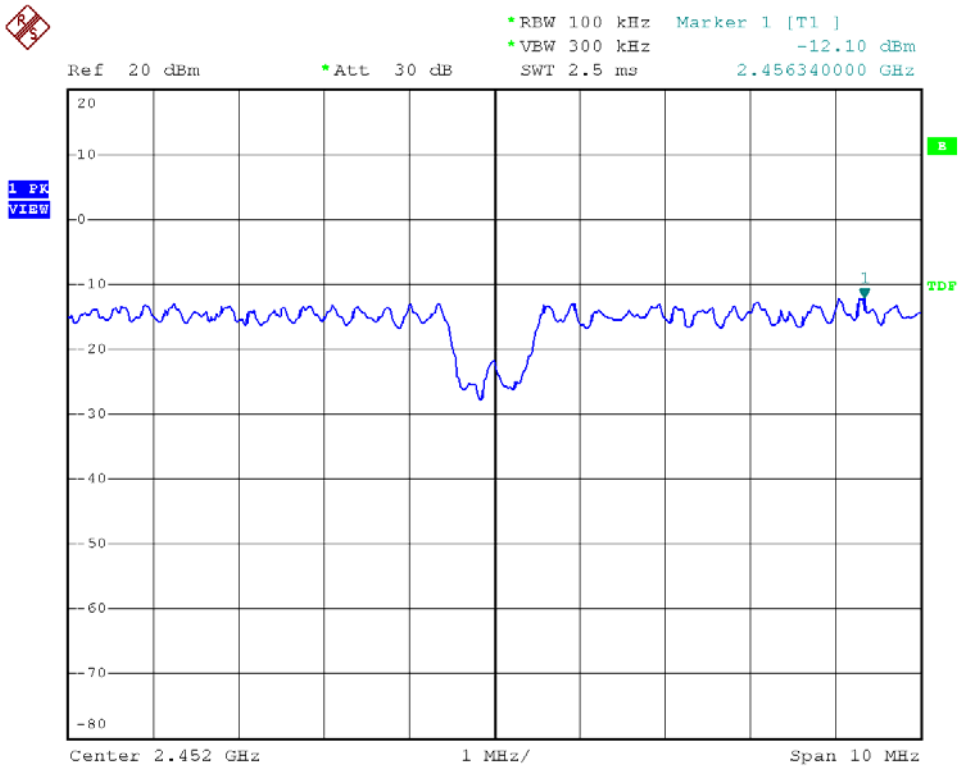



9. Band Edges Measurement

9.1 Test Limit

Below -20dB of the highest emission level of operating band (In 100 kHz Resolution Bandwidth)

9.2 Test Procedure

- a. The transmitter output was connected to the spectrum analyzer via a low lose cable.
- b. Set RBW of spectrum analyzer to 100 KHz and VBW of spectrum analyzer to 300 KHz with convenient frequency span including 100 KHz bandwidth from band edge.
- c. Peak conducted output power measured within any 100 kHz outside the authorized frequency band shall be attenuated by at least 20dB relative to the maximum measured in-band peak PSD level.
- d. The band edges was measured and recorded.

9.3 Test Setup Layout

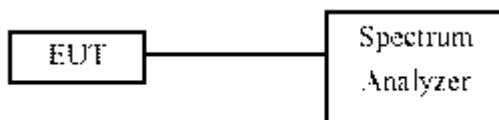

9.4 Measurement Equipment

Instrument/Ancillary	Manufacturer	Model No.	Serial No.	Calibration Date	Valid Date
Spectrum Analyzer	R&S	FSP40	100219	2011/11/24	2012/11/23



9.5 Test Result and Data

Test Date: Aug. 07, 2012

Temperature: 25°C

Atmospheric pressure: 1020 hPa

Humidity: 65%

Modulation Standard	Channel	Frequency (MHz)	ANT R		
			maximum value in frequency (MHz)	maximum value (dBm)	Limit (dBm)
802.11b (11Mbps)	01	2412	2397.90	-49.04	-36.14
	11	2462	2522.10	-55.62	-36.56
802.11g (54Mbps)	01	2412	2400.00	-47.27	-44.40
	11	2462	2514.90	-54.68	-44.28
802.11n HT20 (130Mbps)	01	2412	2399.80	-46.28	-44.45
	11	2462	2526.50	-53.39	-46.12
802.11n HT40 (270Mbps)	03	2422	2399.00	-49.27	-48.27
	09	2452	2485.20	-54.90	-48.50

Modulation Standard	Channel	Frequency (MHz)	ANT L		
			maximum value in frequency (MHz)	maximum value (dBm)	Limit (dBm)
802.11b (11Mbps)	01	2412	2398.00	-48.26	-36.10
	11	2462	2501.70	-54.95	-35.94
802.11g (54Mbps)	01	2412	2400.00	-46.50	-45.54
	11	2462	2504.40	-55.02	-45.51
802.11n HT20 (130Mbps)	01	2412	2400.00	-48.72	-46.23
	11	2462	2514.90	-54.70	-44.72
802.11n HT40 (270Mbps)	03	2422	2398.80	-49.15	-48.55
	09	2452	2485.70	-52.74	-47.30



Modulation Standard: 802.11b (11Mbps), ANT R
Channel: 01



Ref 10 dBm *Att 20 dB *RBW 100 kHz Marker 1 [T1]
*VW 300 kHz -49.04 dBm
SWT 10 ms 2.397900000 GHz

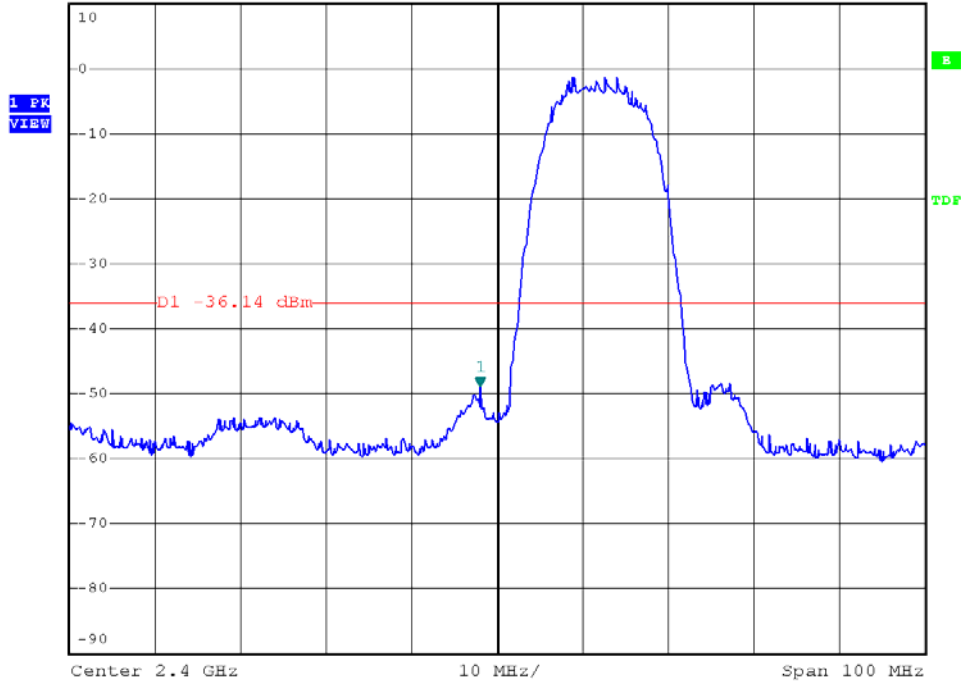

Ref 0 dBm *Att 10 dB *RBW 100 kHz Marker 1 [T1]
*VW 300 kHz -62.09 dBm
SWT 2.25 s 20.230000000 GHz

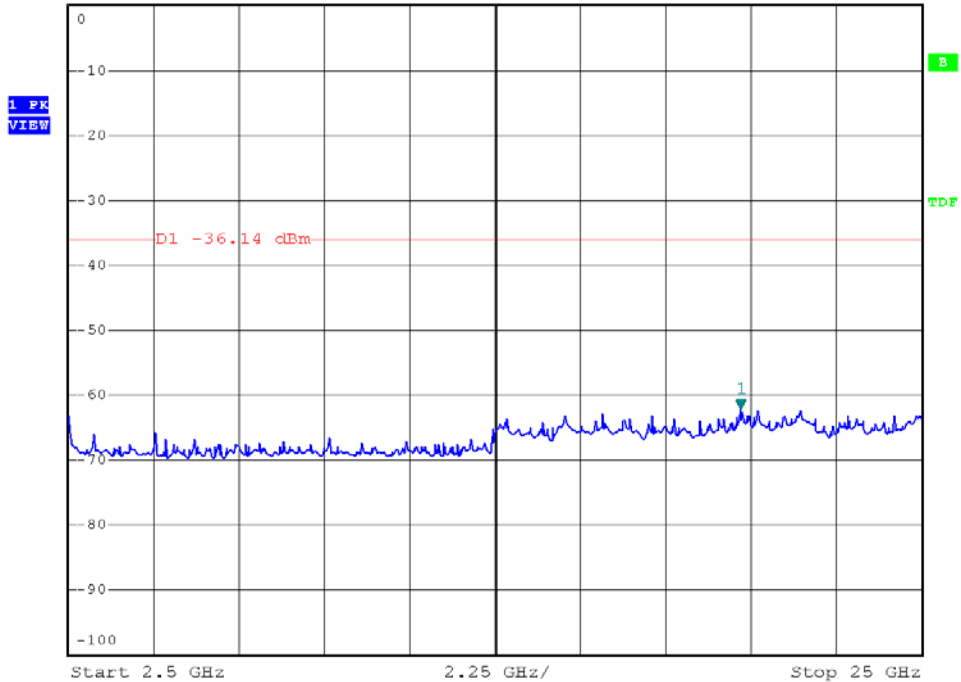



Modulation Standard: 802.11b (11Mbps), ANT R
Channel: 11

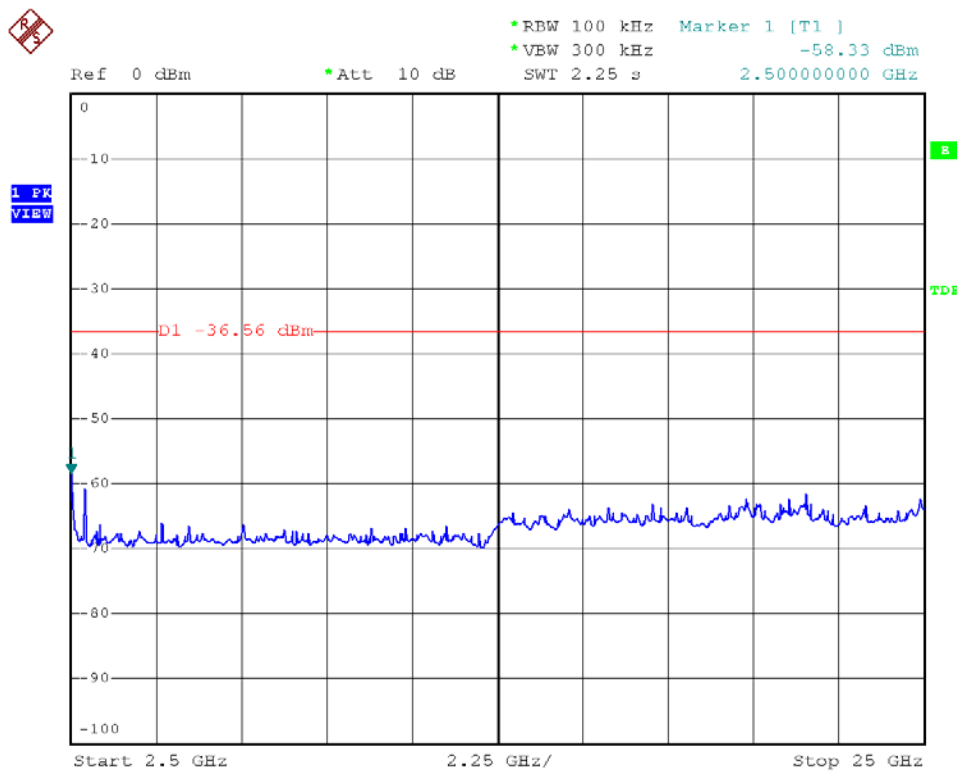
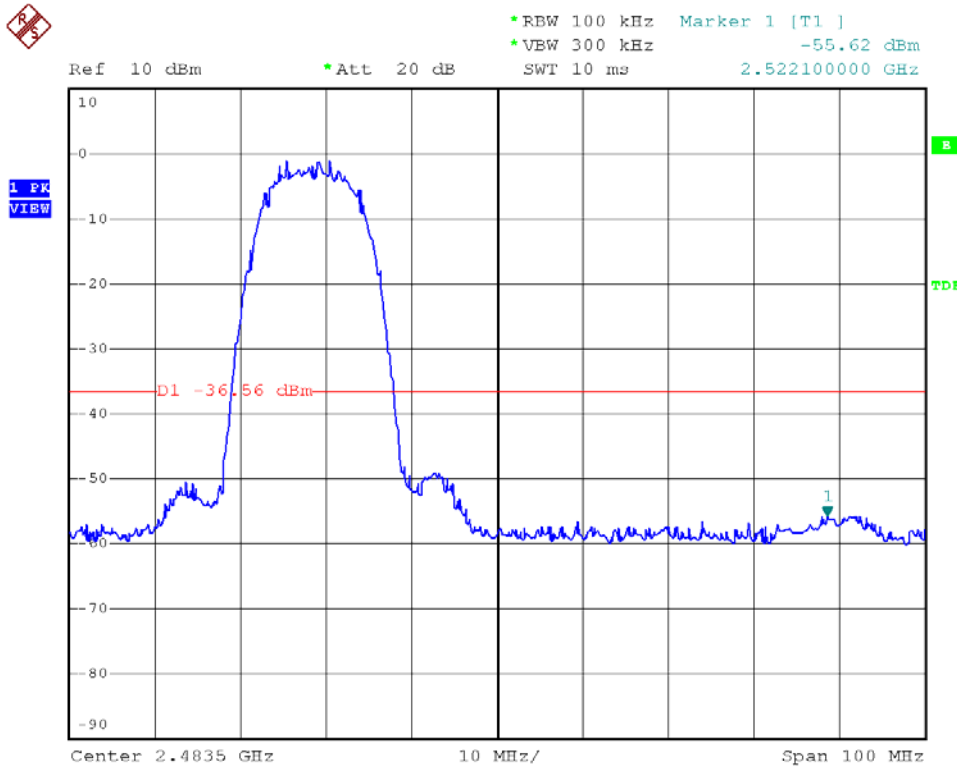



Modulation Standard: 802.11g (54Mbps), ANT R
Channel: 01

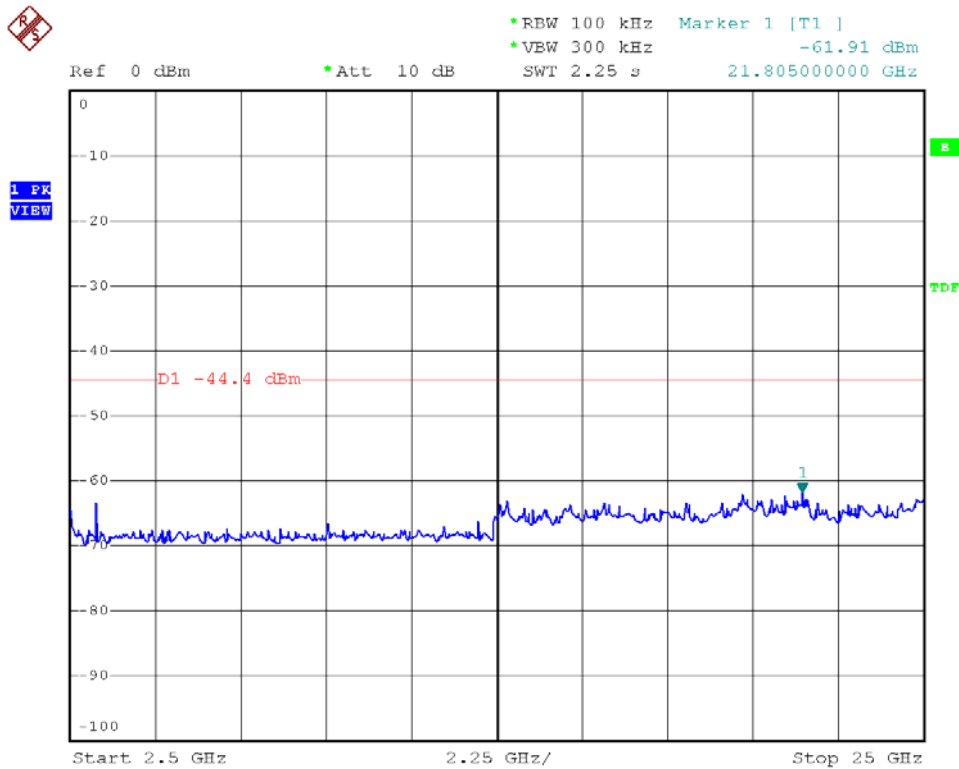
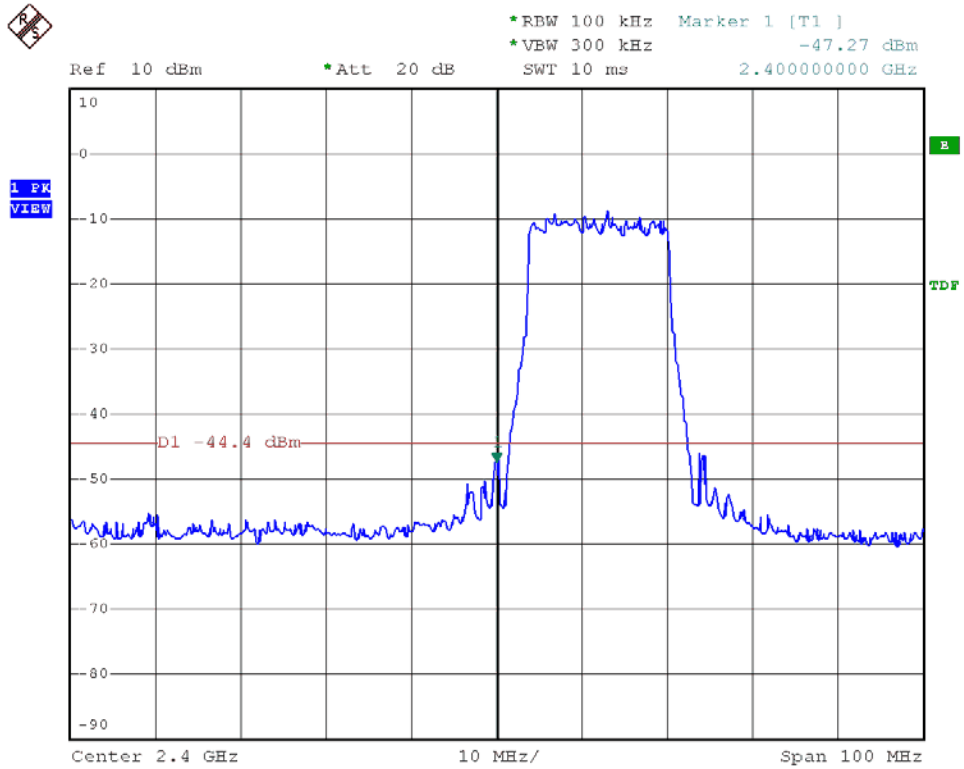



Modulation Standard: 802.11g (54Mbps), ANT R
Channel: 11

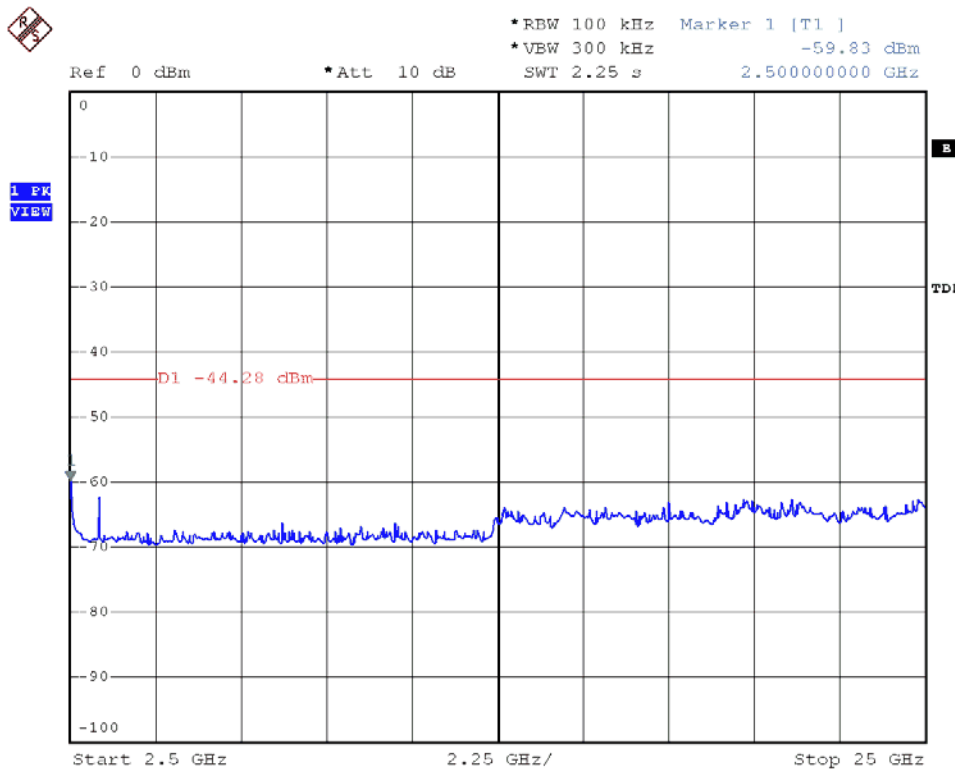
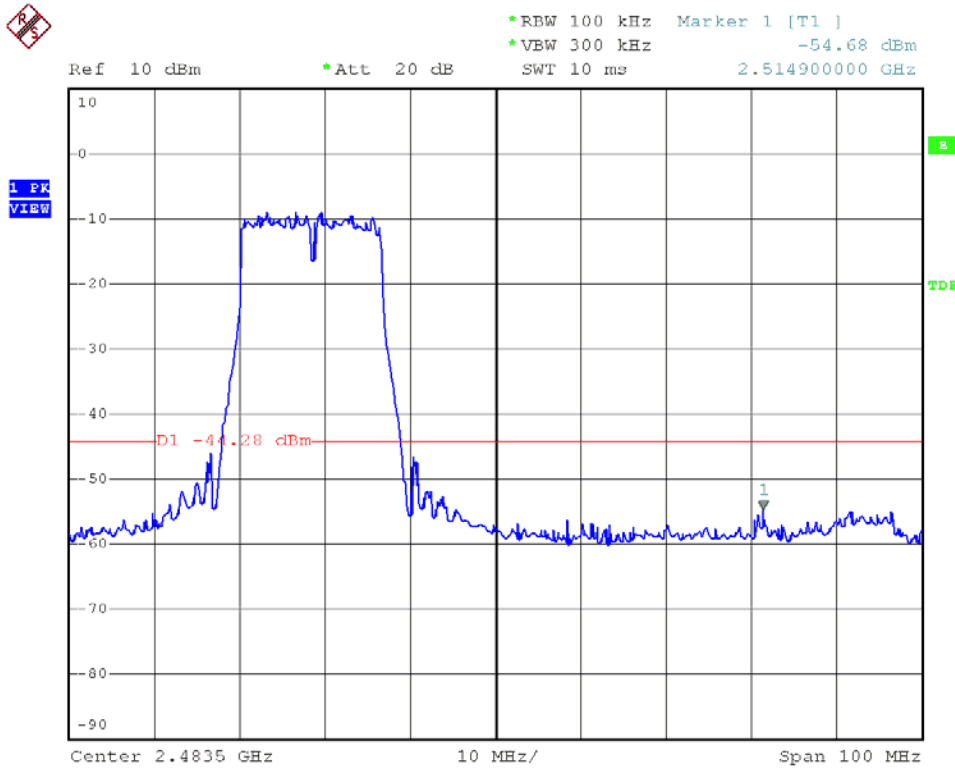



Modulation Standard: 802.11n HT20 (130Mbps), ANT R
Channel: 01

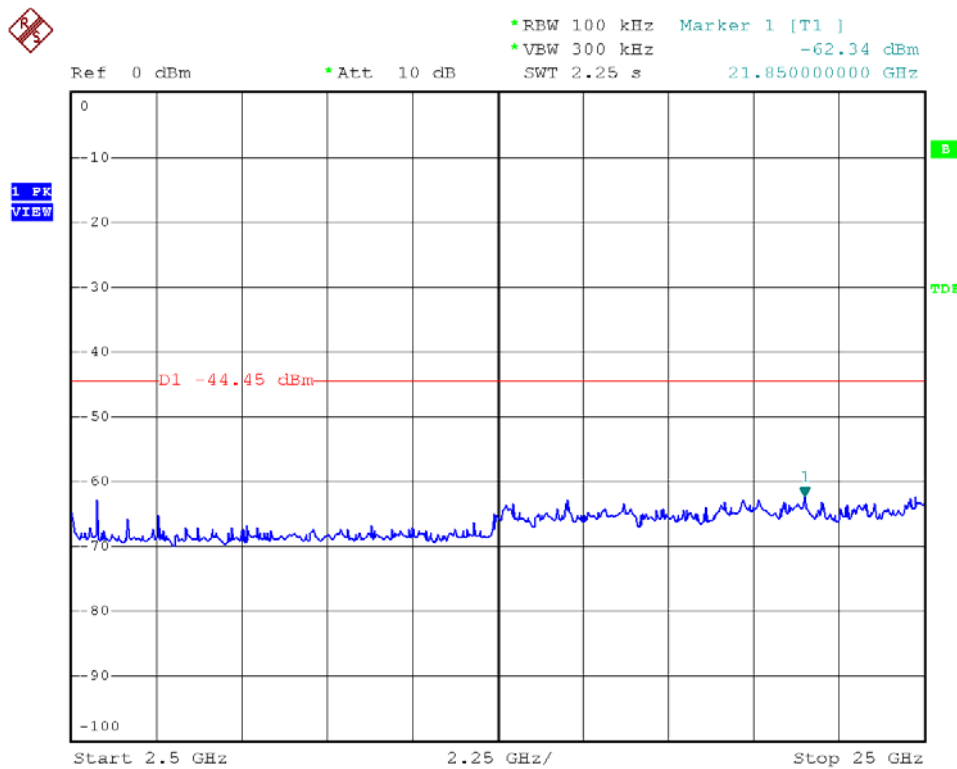
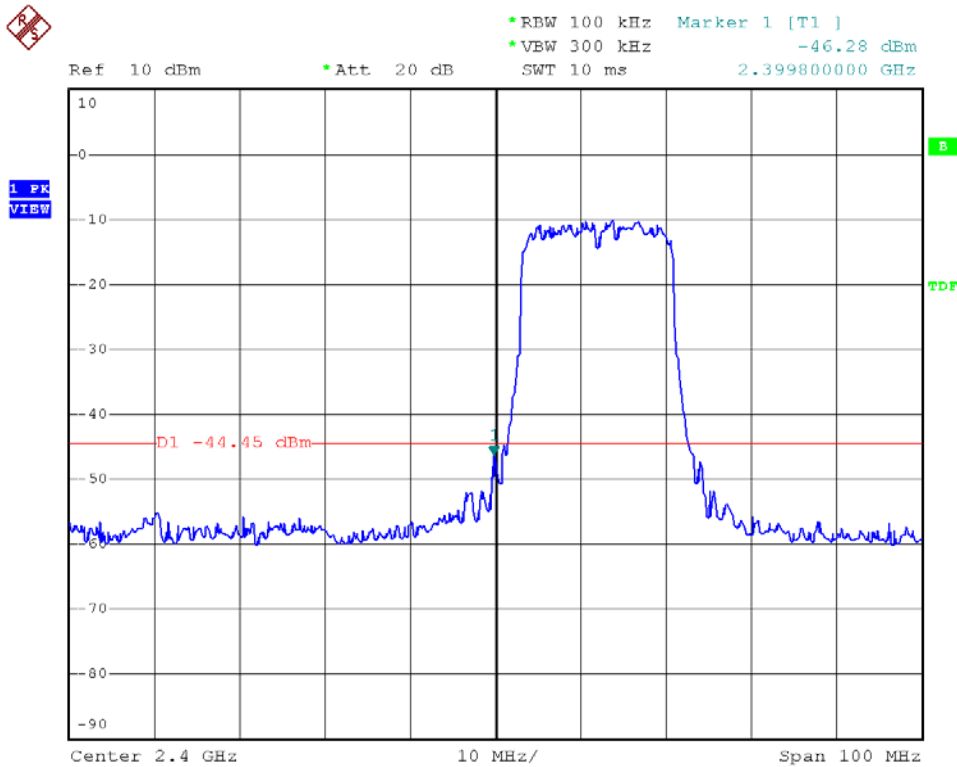



Modulation Standard: 802.11n HT20 (130Mbps), ANT R
Channel: 11

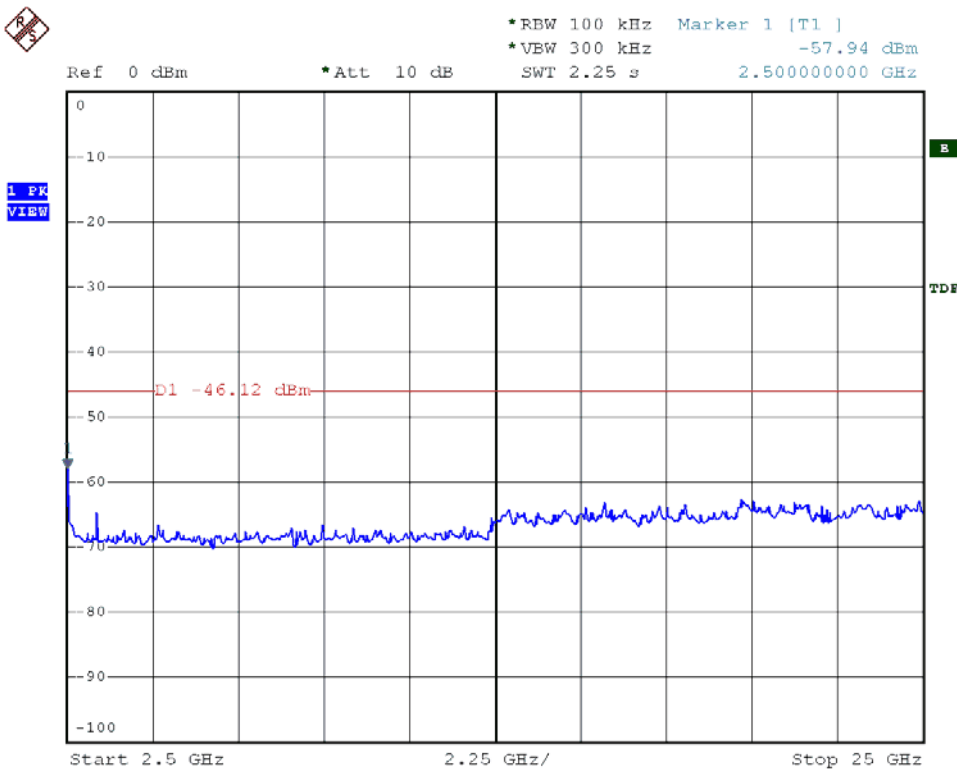
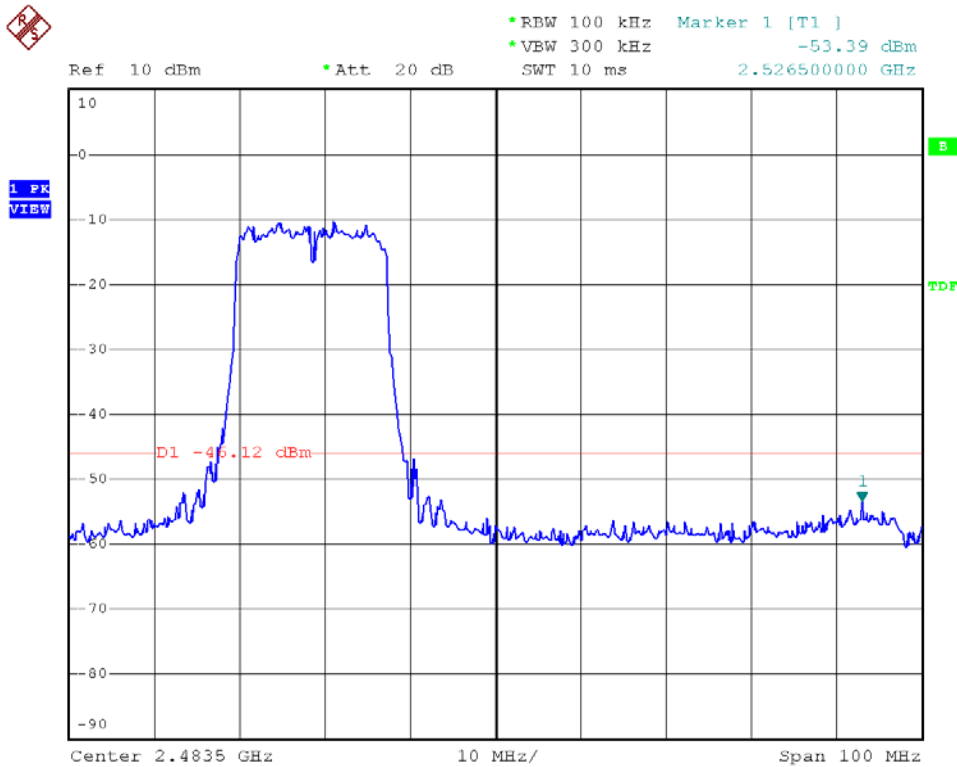



Modulation Standard: 802.11n HT40 (270Mbps), ANT R
Channel: 03

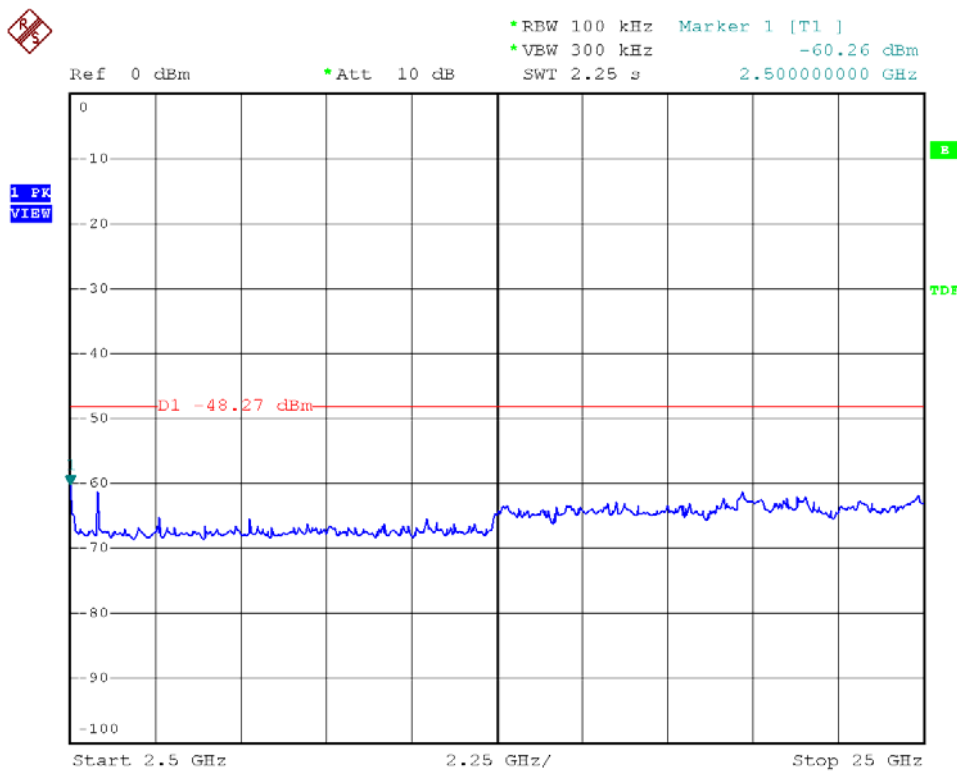
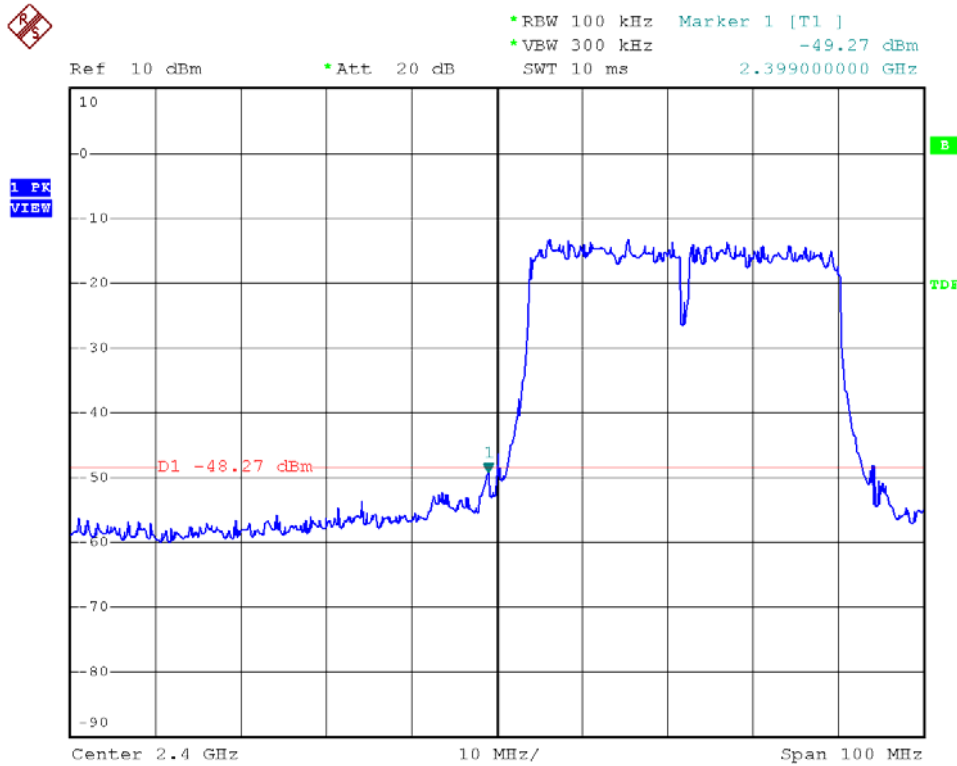



Modulation Standard: 802.11n HT40 (270Mbps), ANT R
Channel: 09

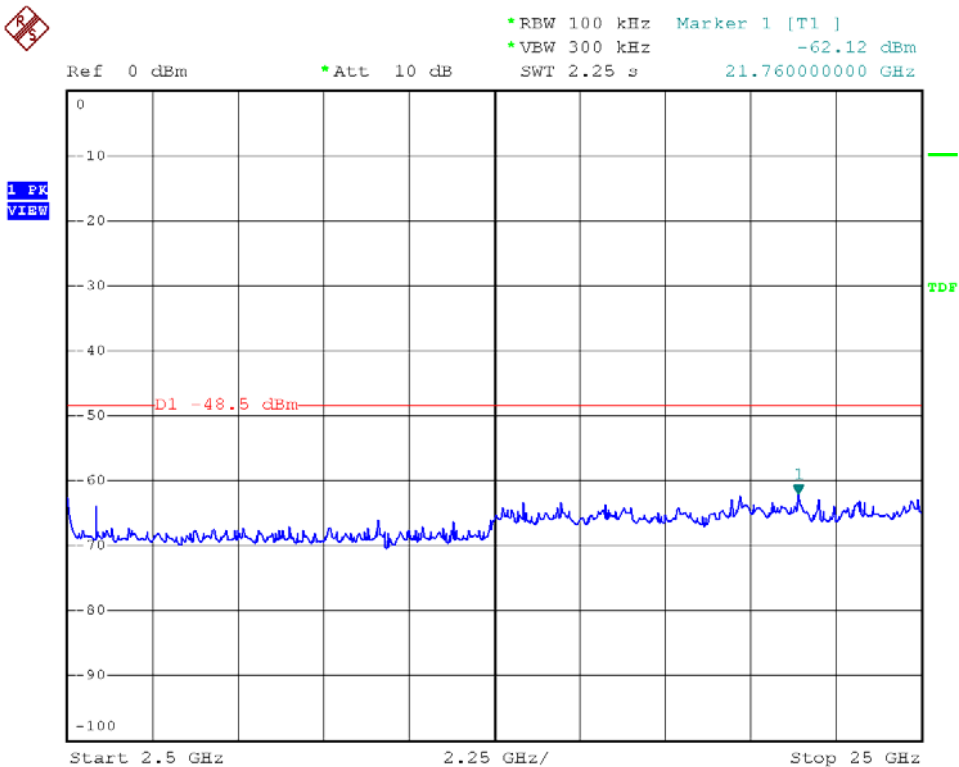
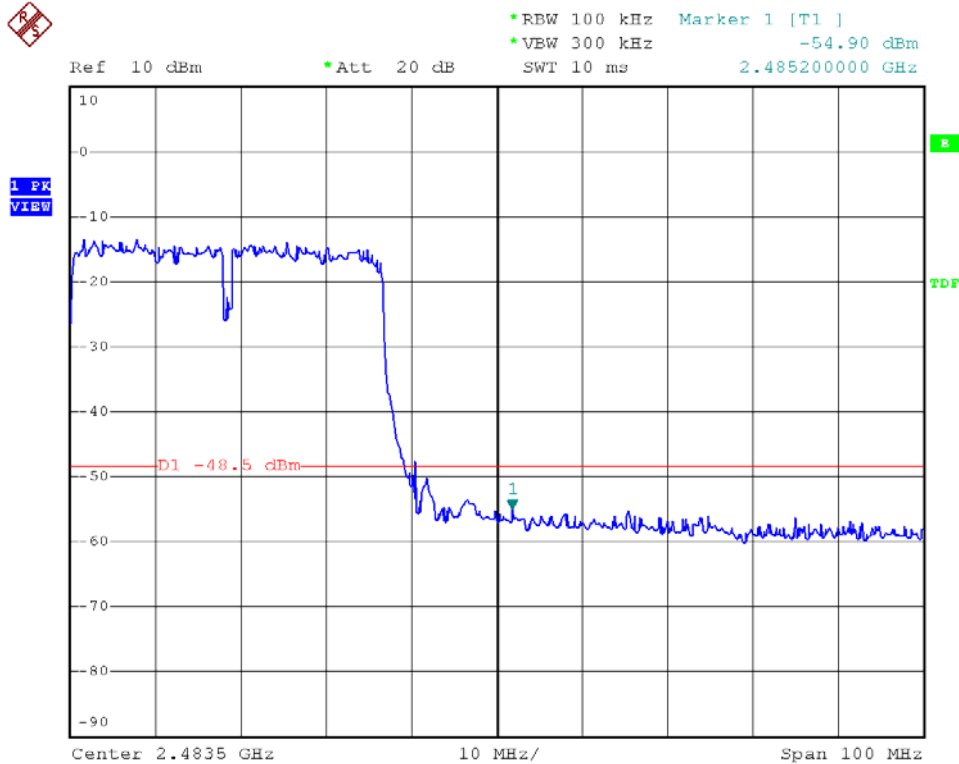



Modulation Standard: 802.11b (11Mbps), ANT L
Channel: 01



Ref 10 dBm *Att 20 dB *RBW 100 kHz Marker 1 [T1]
*VW 300 kHz -48.26 dBm
SWT 10 ms 2.398000000 GHz

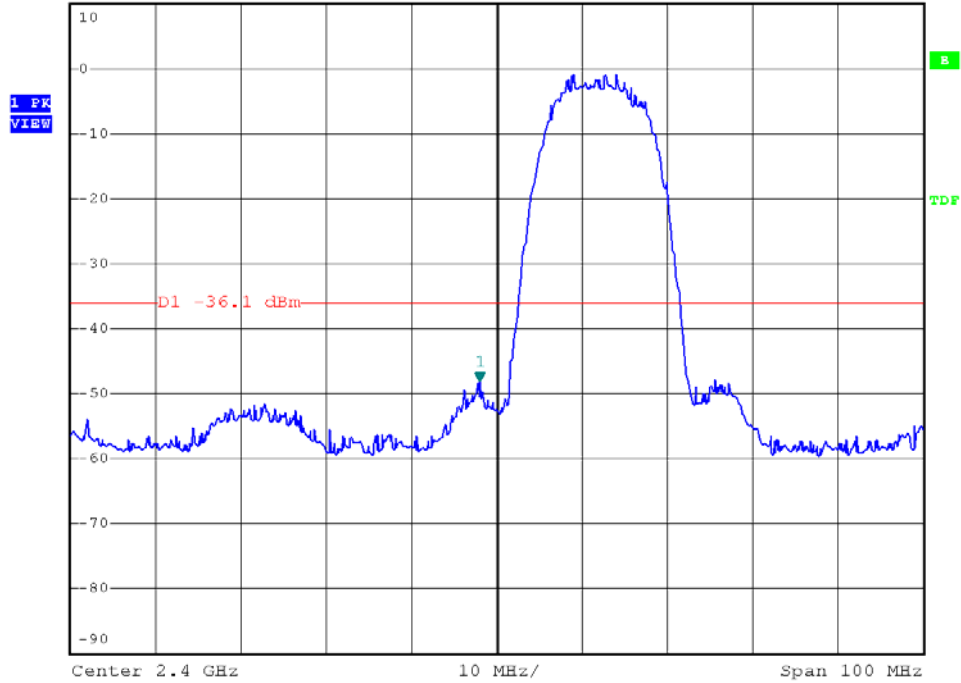

Ref 0 dBm *Att 10 dB *RBW 100 kHz Marker 1 [T1]
*VW 300 kHz -53.57 dBm
SWT 2.25 s 3.175000000 GHz

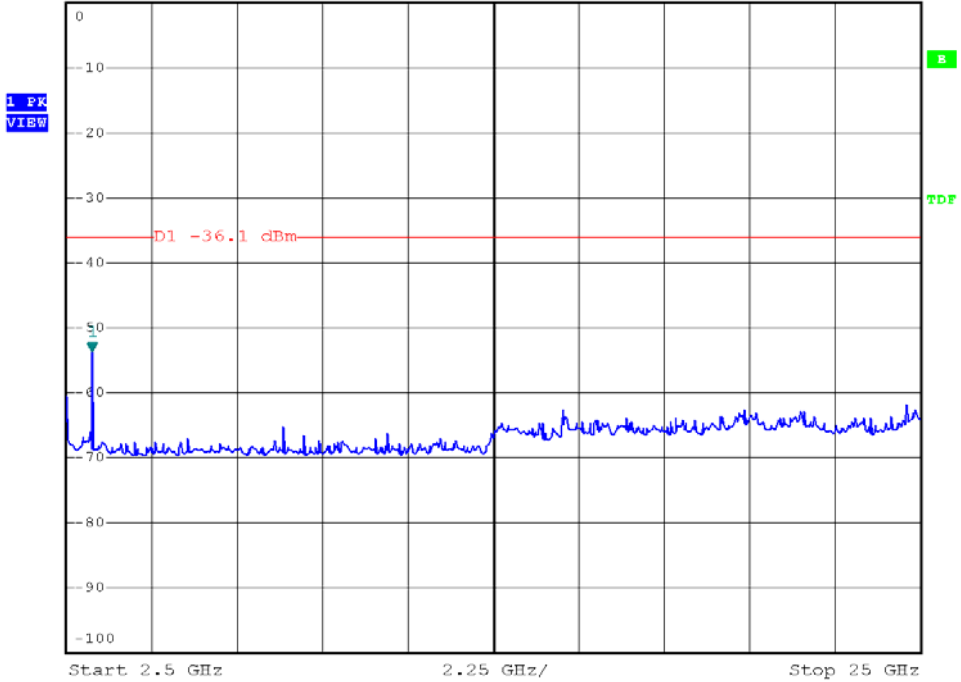



Modulation Standard: 802.11b (11Mbps), ANT L
Channel: 11

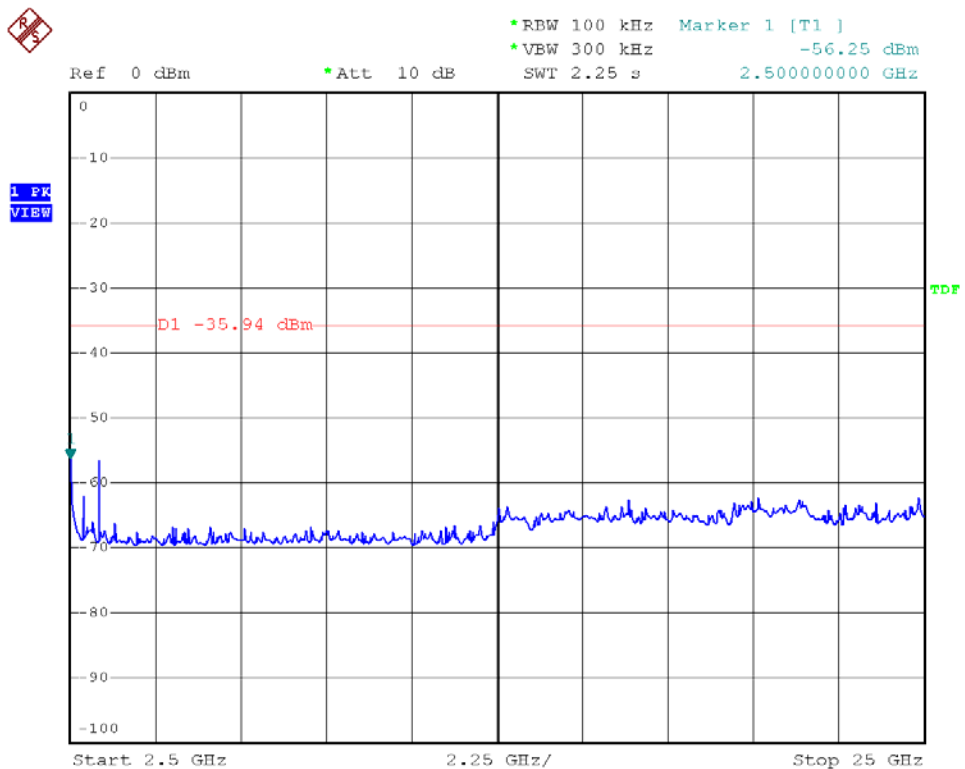
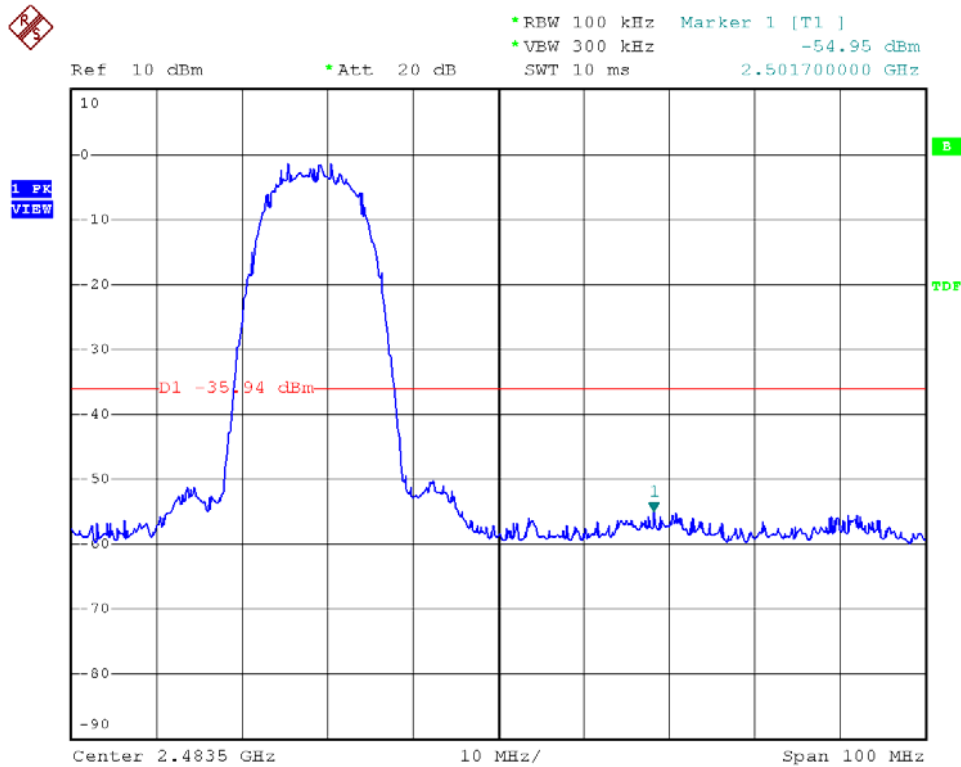



Modulation Standard: 802.11g (54Mbps), ANT L
Channel: 01



Ref 10 dBm *Att 20 dB RBW 100 kHz Marker 1 [T1]
*VBW 300 kHz -46.50 dBm
SWT 10 ms 2.400000000 GHz

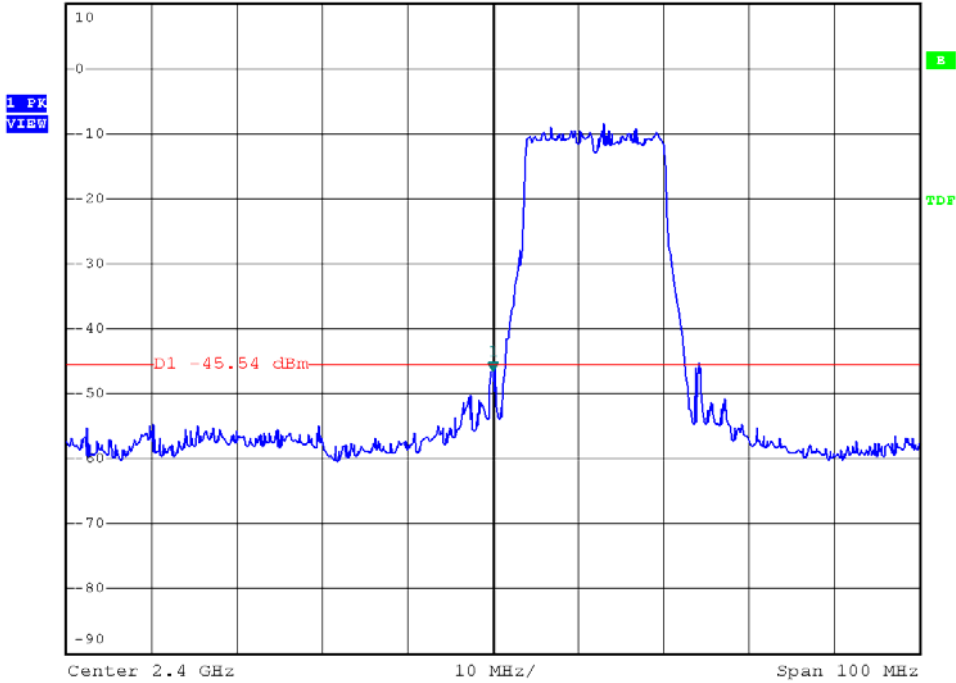

Ref 0 dBm *Att 10 dB RBW 100 kHz Marker 1 [T1]
*VBW 300 kHz -52.92 dBm
SWT 2.25 s 3.175000000 GHz

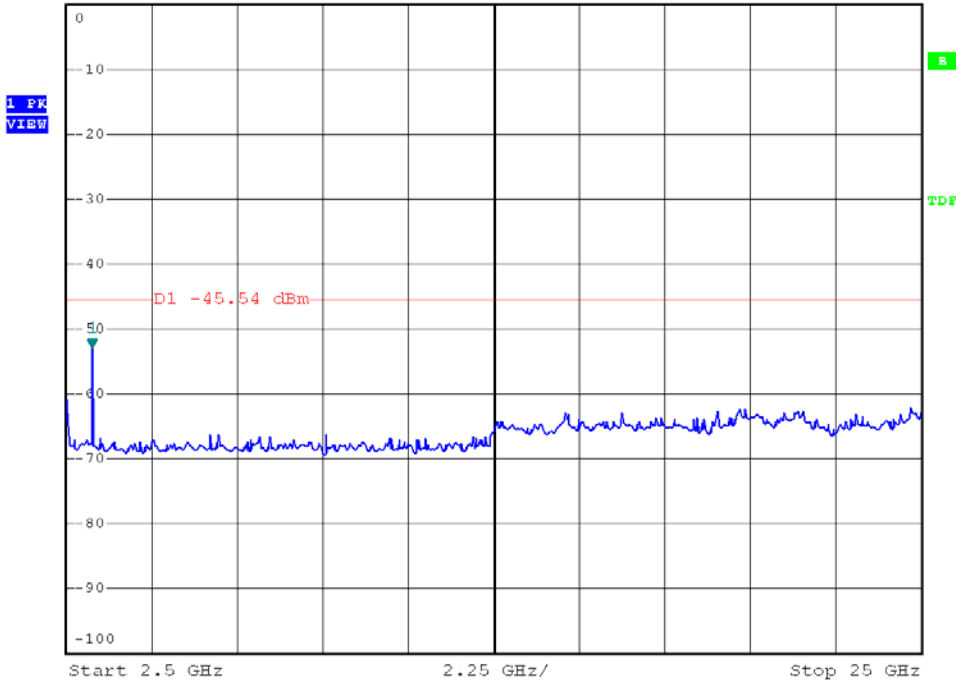



Modulation Standard: 802.11g (54Mbps), ANT L
Channel: 11



Ref 10 dBm *Att 20 dB *RBW 100 kHz Marker 1 [T1]
*VBW 300 kHz -55.02 dBm
SWT 10 ms 2.504400000 GHz

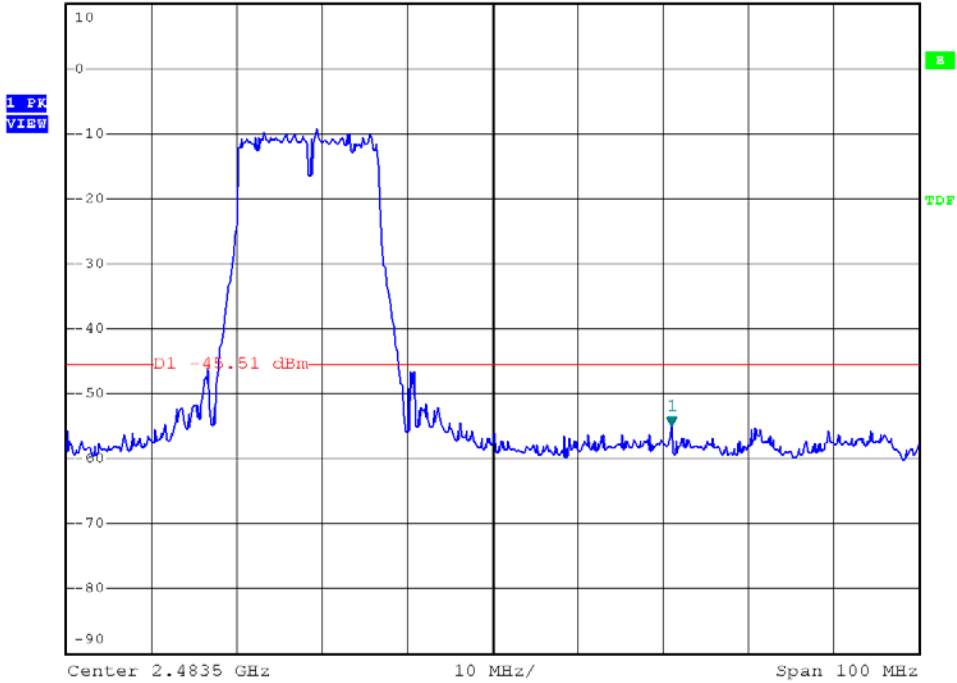

Ref 0 dBm *Att 10 dB *RBW 100 kHz Marker 1 [T1]
*VBW 300 kHz -56.42 dBm
SWT 2.25 s 3.265000000 GHz

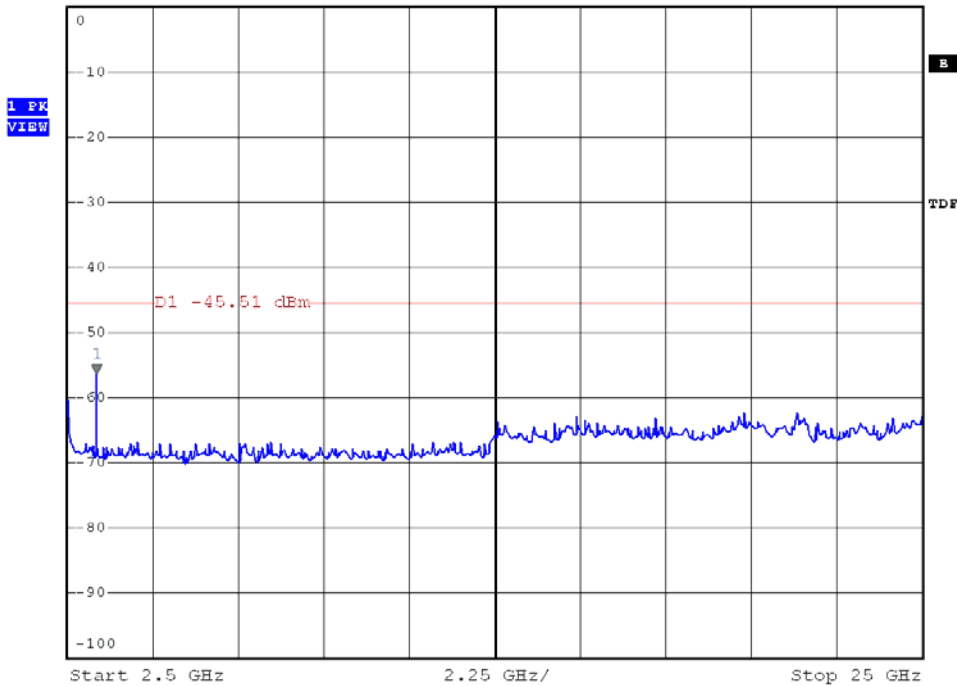



Modulation Standard: 802.11n HT20 (130Mbps), ANT L
Channel: 01



*RBW 100 kHz Marker 1 [T1]
*VBW 300 kHz -48.72 dBm
Ref 10 dBm *Att 20 dB SWT 10 ms 2.400000000 GHz

1 PK
VIEW

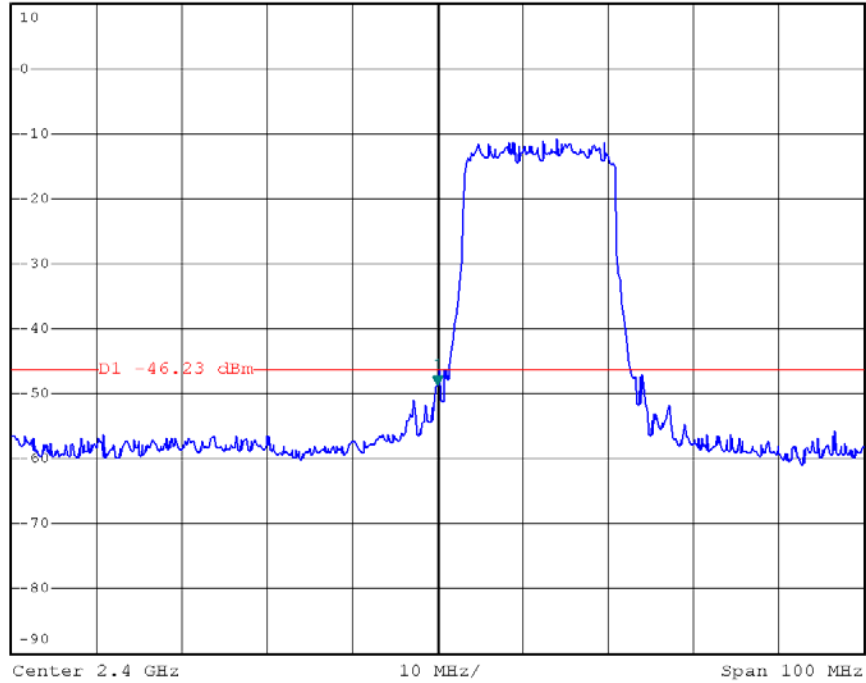

*RBW 100 kHz Marker 1 [T1]
*VBW 300 kHz -54.98 dBm
Ref 0 dBm *Att 10 dB SWT 2.25 s 3.175000000 GHz

1 PK
VIEW

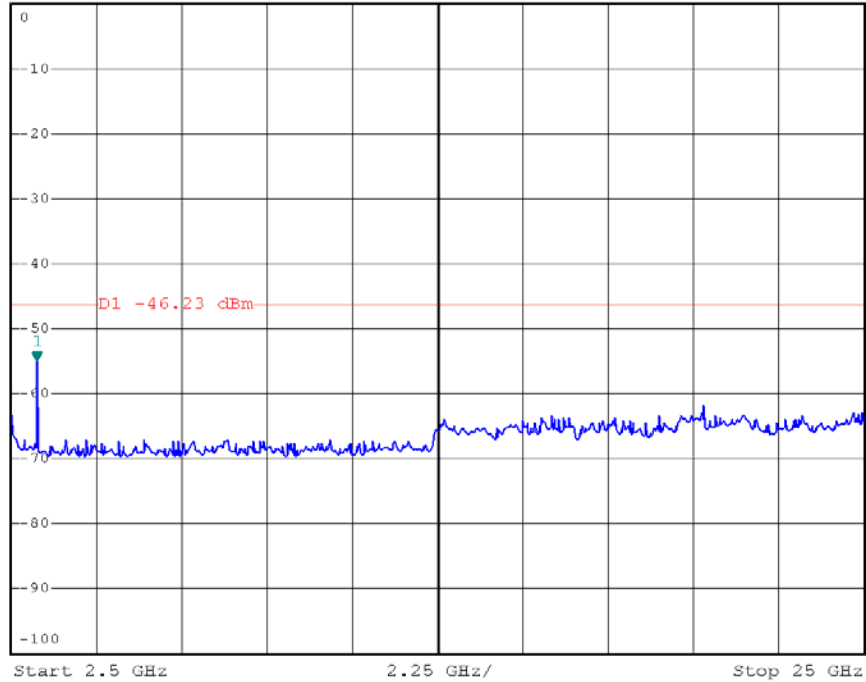



Modulation Standard: 802.11n HT20 (130Mbps), ANT L
Channel: 11

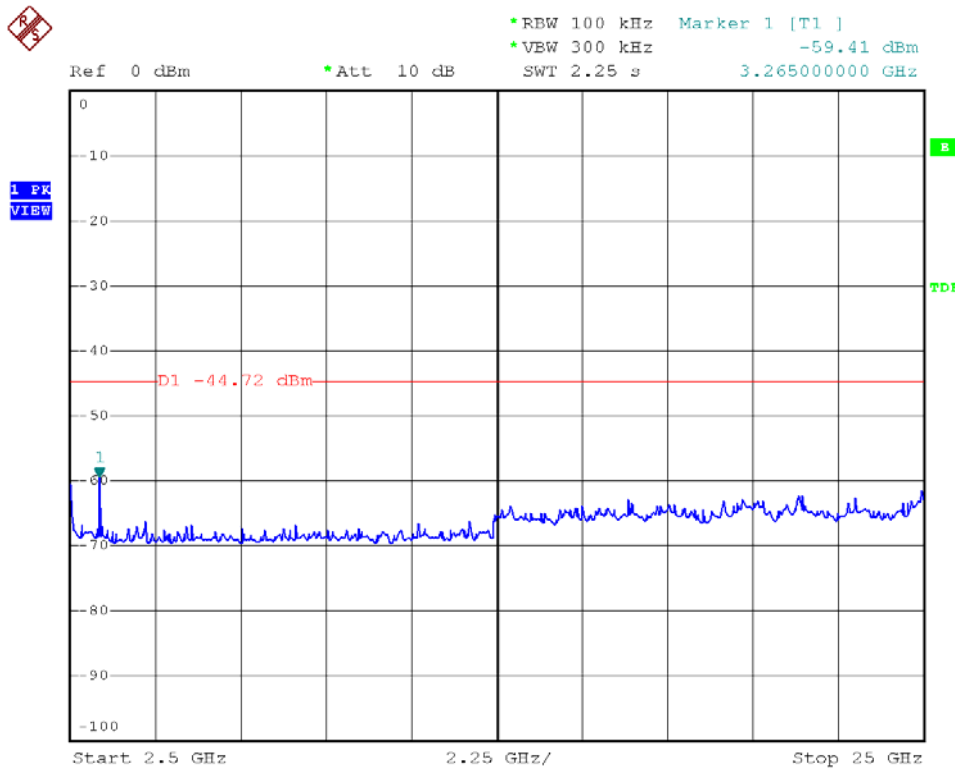
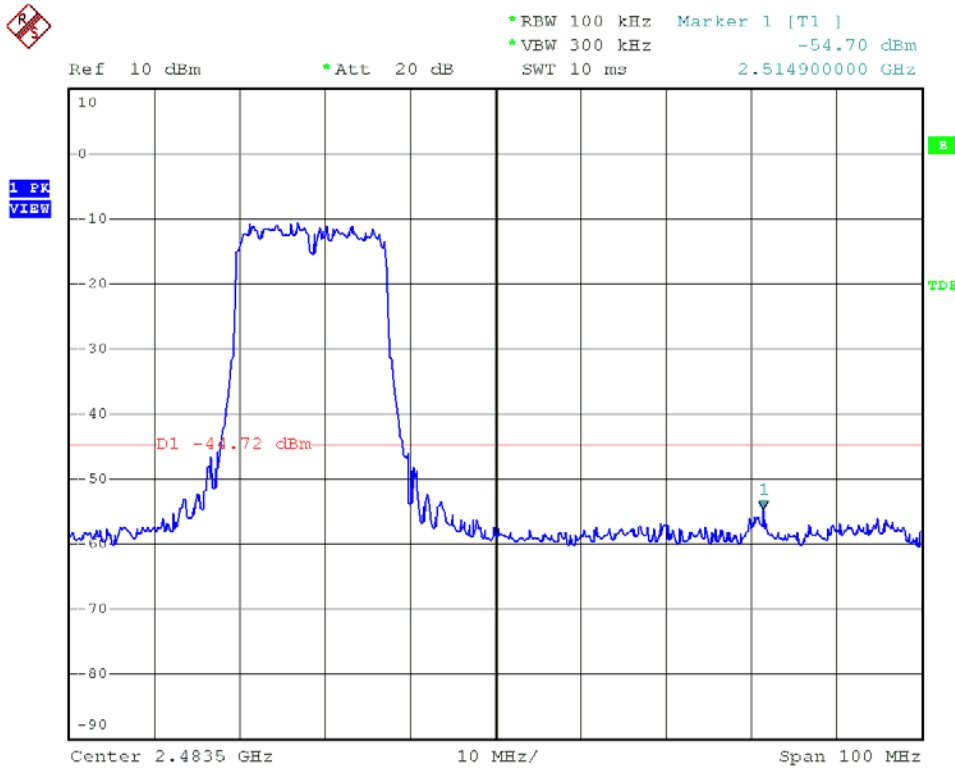



Modulation Standard: 802.11n HT40 (270Mbps), ANT L
Channel: 03

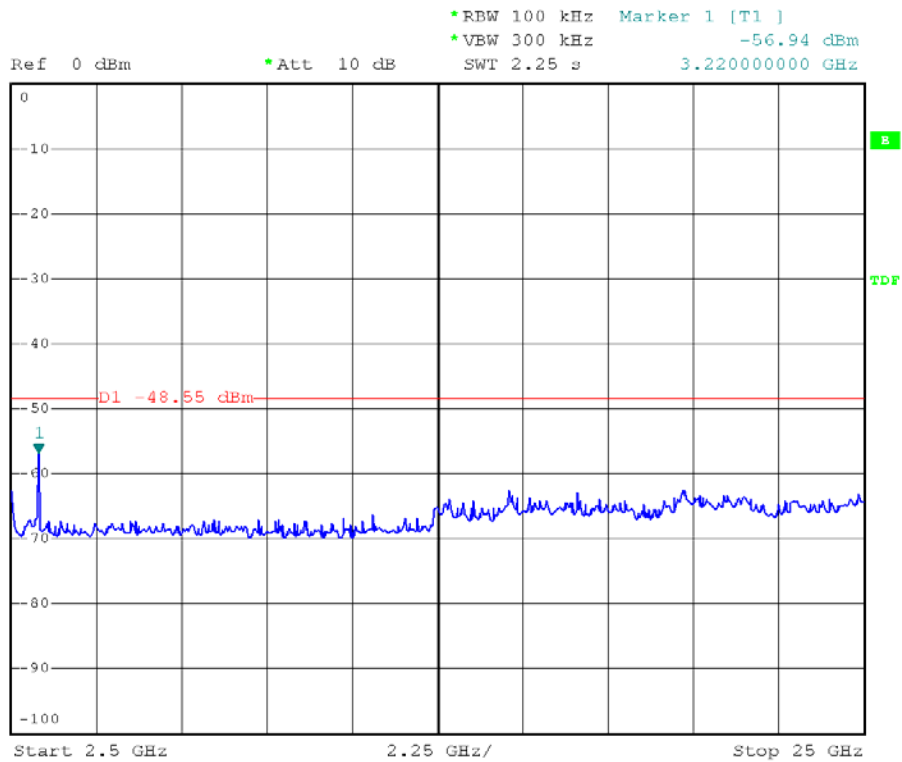
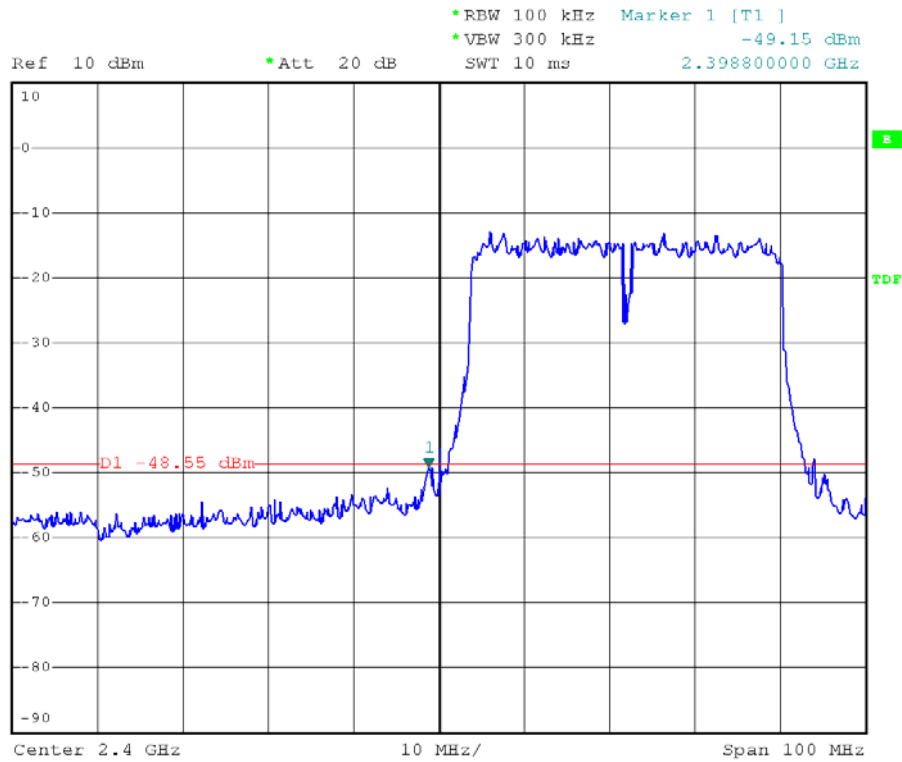



Modulation Standard: 802.11n HT40 (270Mbps), ANT L
Channel: 09

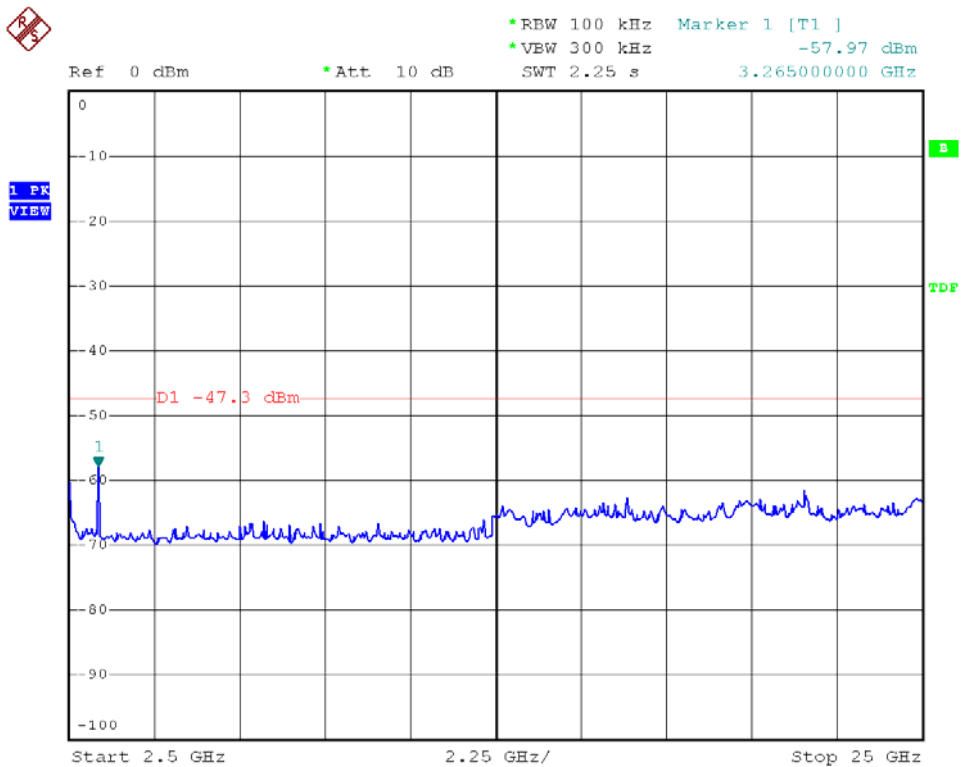
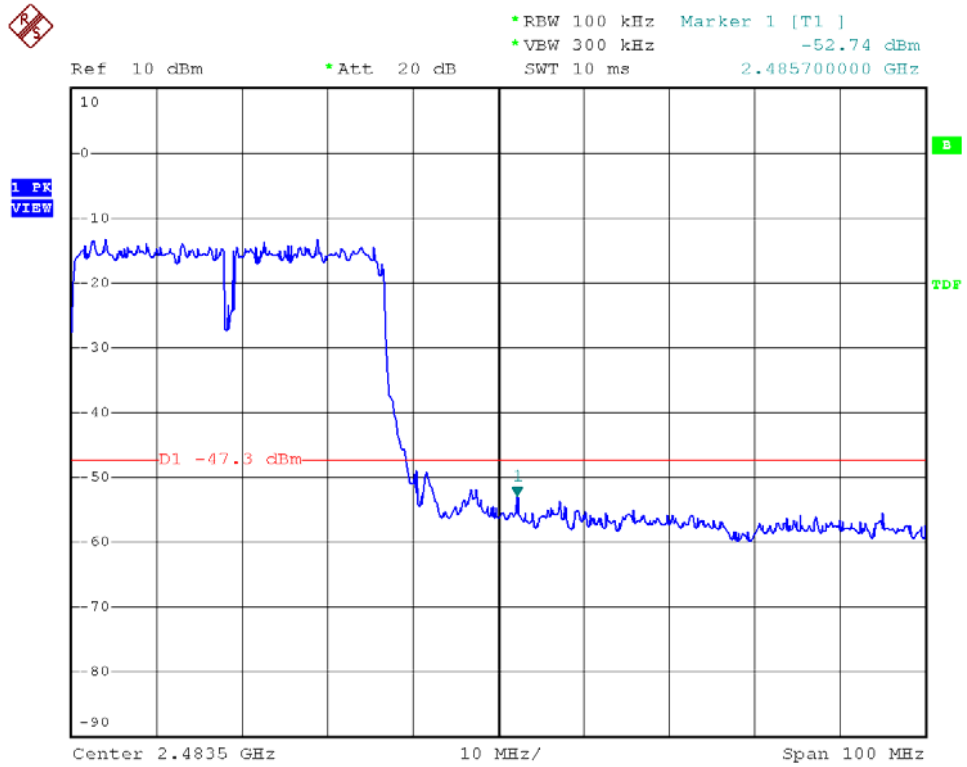



9.6 Restrict Band Emission Measurement Data

Test Date: Aug. 09, 2012

Temperature: 23 °C

Atmospheric pressure: 1020 hPa

Humidity: 65 %

Modulation Standard: IEEE 802.11b (11Mbps)

Channel 1						Fundamental Frequency: 2412 MHz				
Frequency (MHz)	Ant-Pol H/V	Meter Reading (dBuV)	Corrected Factor (dB)	Result (dBuV/m)	Remark	Limit (dBuV/m)		Margin (dB)	Table Deg.	Ant High (m)
						Peak	Ave			
2329.89	H	47.26	1.70	48.96	Peak	74	54	-25.04	360	1.00
---	H	---	---	---	Ave	74	54	---	---	---
2359.98	V	53.06	2.57	55.63	Peak	74	54	-18.37	360	1.00
2359.98	V	45.62	2.57	48.19	Ave	74	54	-5.81	0	1.00
Channel 11						Fundamental Frequency: 2462 MHz				
Frequency (MHz)	Ant-Pol H/V	Meter Reading (dBuV)	Corrected Factor (dB)	Result (dBuV/m)	Remark	Limit (dBuV/m)		Margin (dB)	Table Deg.	Ant High (m)
						Peak	Ave			
2499.24	H	50.00	-0.14	49.86	Peak	74	54	-24.14	46	1.00
---	H	---	---	---	Ave	74	54	---	---	---
2483.96	V	60.24	-2.57	57.67	Peak	74	54	-16.33	0	1.00
2483.86	V	43.76	-2.56	41.20	Ave	74	54	-12.80	184	1.02

Modulation Standard: IEEE 802.11g (54Mbps)

Channel 1						Fundamental Frequency: 2412 MHz				
Frequency (MHz)	Ant-Pol H/V	Meter Reading (dBuV)	Corrected Factor (dB)	Result (dBuV/m)	Remark	Limit (dBuV/m)		Margin (dB)	Table Deg.	Ant High (m)
						Peak	Ave			
2312.85	H	46.96	1.78	48.74	Peak	74	54	-25.26	34	1.00
---	H	---	---	---	Ave	74	54	---	---	---
2359.47	V	50.50	2.58	53.08	Peak	74	54	-20.92	266	1.00
---	V	---	---	---	Ave	74	54	---	---	---
Channel 11						Fundamental Frequency: 2462 MHz				
Frequency (MHz)	Ant-Pol H/V	Meter Reading (dBuV)	Corrected Factor (dB)	Result (dBuV/m)	Remark	Limit (dBuV/m)		Margin (dB)	Table Deg.	Ant High (m)
						Peak	Ave			
2499.69	H	50.17	-0.14	50.03	Peak	74	54	-23.97	360	1.00
---	H	---	---	---	Ave	74	54	---	---	---
2483.96	V	53.44	-2.57	50.87	Peak	74	54	-23.13	103	1.00
---	V	---	---	---	Ave	74	54	---	---	---



Modulation Standard: IEEE 802.11n HT20 (130Mbps)

Channel 1						Fundamental Frequency: 2412 MHz				
Frequency (MHz)	Ant-Pol H/V	Meter Reading (dBuV)	Corrected Factor (dB)	Result (dBuV/m)	Remark	Limit (dBuV/m)		Margin (dB)	Table Deg.	Ant High (m)
						Peak	Ave			
2340.09	H	47.44	1.66	49.10	Peak	74	54	-24.90	0	1.00
---	H	---	---	---	Ave	74	54	---	---	---
2359.77	V	51.31	2.57	53.88	Peak	74	54	-20.12	360	1.00
---	V	---	---	---	Ave	74	54	---	---	---

Channel 11						Fundamental Frequency: 2462 MHz				
Frequency (MHz)	Ant-Pol H/V	Meter Reading (dBuV)	Corrected Factor (dB)	Result (dBuV/m)	Remark	Limit (dBuV/m)		Margin (dB)	Table Deg.	Ant High (m)
						Peak	Ave			
2496.20	H	49.86	-0.09	49.77	Peak	74	54	-24.23	360	1.00
---	H	---	---	---	Ave	74	54	---	---	---
2496.20	V	53.71	-3.22	50.49	Peak	74	54	-23.51	0	1.00
---	V	---	---	---	Ave	74	54	---	---	---

Modulation Standard: IEEE 802.11n HT40 (270Mbps)

Channel 3						Fundamental Frequency: 2422 MHz				
Frequency (MHz)	Ant-Pol H/V	Meter Reading (dBuV)	Corrected Factor (dB)	Result (dBuV/m)	Remark	Limit (dBuV/m)		Margin (dB)	Table Deg.	Ant High (m)
						Peak	Ave			
2323.05	H	47.49	1.73	49.22	Peak	74	54	-24.78	0	1.00
---	H	---	---	---	Ave	74	54	---	---	---
2388.36	V	51.50	2.10	53.60	Peak	74	54	-20.40	358	1.00
---	V	---	---	---	Ave	74	54	---	---	---

Channel 9						Fundamental Frequency: 2452 MHz				
Frequency (MHz)	Ant-Pol H/V	Meter Reading (dBuV)	Corrected Factor (dB)	Result (dBuV/m)	Remark	Limit (dBuV/m)		Margin (dB)	Table Deg.	Ant High (m)
						Peak	Ave			
2494.87	H	49.39	-0.07	49.32	Peak	74	54	-24.68	360	1.00
---	H	---	---	---	Ave	74	54	---	---	---
2483.58	V	57.11	-2.54	54.57	Peak	74	54	-19.43	360	1.00
2483.58	V	44.06	-2.54	41.52	Ave	74	54	-12.48	0	1.00

Notes:

1. Result = Meter Reading + Factor
2. Factor = Antenna Factor + Cable Loss – Amplifier
3. The resolution bandwidth of test receiver/spectrum analyzer is 1MHz and video bandwidth is 3 MHz (detector peak mode) for Peak detection at frequency above 1GHz.
4. The resolution bandwidth of test receiver/spectrum analyzer is 1MHz and video bandwidth is 3 MHz (detector sample mode) for Average detection at frequency above 1GHz.



10. Restricted Bands of Operation

Only spurious emissions are permitted in any of the frequency bands listed below:

MHz	MHz	MHz	GHz
0.09000 – 0.11000	16.42000 – 16.42300	399.9 – 410.0	4.500 – 5.250
0.49500 – 0.505**	16.69475 – 16.69525	608.0 – 614.0	5.350 – 5.460
2.17350 – 2.19050	16.80425 – 16.80475	960.0 – 1240.0	7.250 – 7.750
4.12500 – 4.12800	25.50000 – 25.67000	1300.0 – 1427.0	8.025 – 8.500
4.17725 – 4.17775	37.50000 – 38.25000	1435.0 – 1626.5	9.000 – 9.200
4.20725 – 4.20775	73.00000 – 74.60000	1645.5 – 1646.5	9.300 – 9.500
6.21500 – 6.21800	74.80000 – 75.20000	1660.0 – 1710.0	10.600 – 12.700
6.26775 – 6.26825	108.00000 – 121.94000	1718.8 – 1722.2	13.250 – 13.400
6.31175 – 6.31225	123.00000 – 138.00000	2200.0 – 2300.0	14.470 – 14.500
8.29100 – 8.29400	149.90000 – 150.05000	2310.0 – 2390.0	15.350 – 16.200
8.36200 – 8.36600	156.52475 – 156.52525	2483.5 – 2500.0	17.700 – 21.400
8.37625 – 8.38675	156.70000 – 156.90000	2655.0 – 2900.0	22.010 – 23.120
8.41425 – 8.41475	162.01250 – 167.17000	3260.0 – 3267.0	23.600 – 24.000
12.29000 – 12.29300	167.72000 – 173.20000	3332.0 – 3339.0	31.200 – 31.800
12.51975 – 12.52025	240.00000 – 285.00000	3345.8 – 3358.0	36.430 – 36.500
12.57675 – 12.57725	322.00000 – 335.40000	3600.0 – 4400.0	Above 38.6
13.36000 – 13.41000			

** : Until February 1, 1999, this restricted band shall be 0.490-0.510 MHz

10.1 Labeling Requirement

The device shall bear the following statement in a conspicuous location on the device:
 This device complies with part 15 of the FCC Rules. Operation is subject to the following two conditions: (1) This device may not cause harmful interference, and (2) this device must accept any interference received, including interference that may cause undesired operation.