

Electromagnetic Emission

FCC MEASUREMENT REPORT

CERTIFICATION

OF

FCC PART15 Subpart B COMPLIANCE

PRODUCT : 19 Inch TFT LCD Monitor
MODEL/TYPE NO : AMVX1908, AMM19TK2(HB)
FCC ID : VYGAMVX1908
TRADE NAME : MEDVIX

APPLICANT : AMPRONIX INC.
15 Whatney Irvine CA 92618 USA

FCC CLASSIFICATION : JBP : Part 15 Class B Computer Device Peripheral
FCC RULE PART(S) : FCC Part 15 Subpart B Class B
FCC PROCEDURE : Certification
DATES OF TEST : July 18 to 19, 2005
DATES OF ISSUE : January 21, 2008
TEST REPORT No. : BWS-08-EF-0005
TEST LAB. : BWS TECH Inc. (Registration No. : 553281)

This 19 Inch TFT LCD Monitor has been tested in accordance with the measurement procedures specified in ANSI C63.4-2003 at the BWS TECH/EMC Test Laboratory and has been shown to be complied with the electromagnetic emission limits specified in FCC Rule Part15 Subpart B Section15.107 and 15.109

I attest to the accuracy of data. All measurement herein were performed by me or were made under my supervision and are correct to the best of my knowledge and belief. I assume full responsibility for the completeness of these measurements and vouch for the qualifications of all persons taking them. The results of testing in this report apply to the product/system which was tested only. Other similar equipment will not necessarily produce the same results due to production tolerance and measurement uncertainties.

Jan. 21, 2008

(Date)



Nam, Tae-Hyun
Chief Engineer
Laboratory Division

BWS TECH Inc.

www.bws.co.kr

611-1, Maesan-ri, Mohyeon-myeon, Yongin-si, Gyeonggi-do 449-853, Korea
TEL: +82 31 333 5997 FAX: +82 31 333 0017

TABLE OF CONTENTS

	Pages
1. General Information	3
2. Description of Test Facility	4
3. Product Information	5~6
4. Description of Tests	7~8
5. Test Condition	9~10
6. Test Results	11~23
7. Sample Calculation and Other Information	24~25
8. Test Equipment List	26
Appendix 1. Test Setup Photos	
Appendix 2. FCC ID Label and location	
Appendix 3. External Photos of EUT	
Appendix 4. Internal Photos of EUT	
Appendix 5. Block Diagram	
Appendix 6. User Manual	

FCC TEST REPORT

Scope – Measurement and determination of electromagnetic emission(EME) of radio frequency devices including intentional radiators and/or unintentional radiators for compliance with the technical rules and regulations of the U.S Federal Communications Commission(FCC).

1. General Information

Applicant Name : AMPRONIX INC.
Applicant Address : 15 Whatney Irvine CA 92618 USA
Manufacturer Name : D&T Inc.
Manufacturer Address : Daedeok Valley, 59-6 Jang-Dong, Yuseong-Gu, Daejeon, 305-343, Korea
Contact Person : Brian Yamada
Phone/Fax : Phone : 949-273-8000 / Fax : 949-273-8020

- **EUT Type** : 19 Inch TFT LCD Monitor
- **Model Number** : AMVX1908 , AMM19TK2-TE/ -TEW , AMM19TK2(HB)-TE/ -TEW
- **FCC Identifier** : VYGAMVX1908
- **S/N** : Prototype
- **FCC Rule Part(s)** : Part 15 Subpart B Class B
- **Test Procedure** : ANSI C63.4-2003
- **Date of Tests** : July 18 to 19, 2005
- **Place of Tests** : BWS TECH Inc.
EMC Testing Lab (FCC Registration Number : 553281)
611-1, Maesan-ri, Mohyeon-myeon, Yongin-si, Gyeonggi-do
449-853, Korea
TEL: +82 31 333 5997 FAX: +82 31 333 0017
- **Test Report No.** : BWS-08-EF-0005

2. Description of Test Facility

The measurement for radiated emission test were practiced at the open area test site of BWS TECH Inc. Measurement for conducted emission test were practiced at the semi EMC Anechoic Chamber test site of BWS TECH Inc. facility located at **611-1, Maesan-ri, Mohyeon-myeon, Yongin-si, Gyeonggi-do 449-853, Korea**. The site is constructed in conformance with the requirements of the ANSI C63.4-2003 and CISPR Publication 16. The BWS TECH measurement facility has been filed to the Commission with the FCC for 3 and 10 meter site configurations. Detailed description of test facility was found to be in compliance with the requirements of Section 2.948 FCC Rules according to the ANSI C63.4-2003 and registered to the Federal Communications Commission(Registration Number : 553281).

The measurement procedure described in American National Standard for Method of Measurement of Radio-Noise Emission from Low-Voltage Electrical and Electronic Equipment in the Range of 9kHz to 40GHz (ANSI C.63.4-2003) was used in determining radiated and conducted emissions from the ADVAN Int'l Corp. 19 Inch TFT LCD Monitor Model : AMM19TK2 and Family models.

3. Product Information

3.1 Equipment Description

The AMVX1908 Monitor is an intelligent, microprocessor-based TFT_LCD monitor intended for use in medial application. It has an ergonomically designed display and is compatible with most analog RGB (Red, Green, Blue) display standards.

The AMVX1908 Monitor has the following features:

- **Advanced Viewing Solution (AVS):** Our sophisticated filter extends the viewing angle of the screen image, without sacrificing contrast ratio and brightness.
- **Advanced Timing Setup (ATS):** A unique technology from the One Touch Auto Adjustment. Pressing the Auto Adjust button on the front panel, automatically optimizes position, phase, clock, contrast and color balance. This allows the user to maximize the perfect screen setting in the shortest amount of time.
- **Advanced Mounting Solution (AMS):** Improve flat panel environment, utilizing numerous ergonomic mounting solutions to allow creative use in conjunction to product application.
- The monitor is able to properly function even in case of upgrade video cards or software because of the wide auto-scanning compatibility range without requiring to buy a new monitor.
- The internal microprocessor digitally controls auto-scanning. For horizontal scan frequencies between 24.8 KHz and 60.2 KHz, and vertical scan frequencies between 50.0 Hz and 85.1 Hz. In each frequency mode, the microprocessor-based circuitry allows the monitor to function at the precision-of a fixed frequency.
- The resident memory allows for storing factory default settings and also additional user adjustment parameters.
- The maximum resolution achievable is SXGA (1280 x 1024)
- The compact and sleek cabinet design saves lot of your desk space and makes your desk look neat and tidy.
- The monitor is compliant with VESA-DPMS power management standard. In order to save energy, the monitor must be connected to a system compliant with the standard.

Specification

AMM19TK2/HB	
LCD Panel	48cm/19-inch Color TFT Pane
Type	Active Matrix
Resolution	1280 dots x 1024 lines (Recommended)
Pixel Pitch	0.294mm
Display Color	16 million colors
Response Time	12ms avg. 8ms max
Color Tone	Up to 256 tone
Color Filter	RGB vertical stripe type
Face Finishing	Anti-Glare Hard Coated
Viewing Angle	178°H 178°V (CR>=10)
Video	0.7Vp-p analog RGB & TMDS (PanelLink) Digital 165 MHz x 1
Input Signal	
Sync	2.5~5.0Vp-p separated sync
Input Impedance (Analog)	Video - 75 Ohm Sync - 1k Ohm
Composite Sync	C-Video, S-Video
Digital	3 channel TMDS receiver, single pixel 24 bit MSB-aligned RGB TFT
Scanning Frequency	
Horizontal	31.47~79.8kHz
Vertical	50~85Hz (UP to 85Hz at 1024 x 768 mode and up to 75Hz at 1280 x 1024)
Display Size	
H x V	14.8" x 11.9" (376mm x 301mm)
Brightness, Contrast Ratio, Gray Scales	
Brightness	450 cd/m2, Max
Contrast Ratio	900:1 Typ.
Gray Scales	Up to 256 steps
Signal Input Connector	
Video	HD15-15pin, Digital DVI, NTSC, S-Video
Touchscreen	RS-232 DB-9 (Optional)
Temperature Environment	
Operating Temperature	50° ~ 104°F (10° - 40°C)
Operating Humidity	30 ~ 75%RH (without condensation)
Operating Atmospheric Pressure	700 ~ 1060 hPa
Power Source	
Display Monitor	DC 15V
AC-Adapter	AC100~240V
Regulations	
Safety and EMC	UL60601-1, EN60601-1, EN60601-1-2, CE, IPX1 (The monitor is compliance with IPX1, none touch model only)
Cabinet	
Desktop Stand	17.5inch (W) x 17.8inch (H) x 9.5inch (D)
Free Mount	17.5inch (W) x 14.25inch (H) x 3inch (D)
Weight	
Desktop Stand	19 lb. (8.6Kg)
Free Mount	16 lb. (7.3Kg)
Tilt Base	
	0° Down 28° Up
Optional Module	
	Touch Panel

3.2 Variations covered by this report

Model Difference :

Basic Model : AMMVX1908

Multilisting models :

AMM19TK2(HB), AMM19TK2-TE, AMM19TK2-TEW, AMM19TK2(HB)-TE, AMM19TK2(HB)-TEW

Description for Type designation

Touch Screen Type

- None : No Touch screen type
- TE : Resistive Touchscreen model
- TEW : Surface Wave Touchscreen model

LCD Panel

- (HB) : High brightness type LCD. Max. 420 cd/m²
- None : Normal brightness LCD. Standard 250 cd/ m²

For the measurement, the model AMV1908, AMM19TK2-TE, AMM19TK2(HB)-TEW has been selected and these are considered to be representative for the range of AMVX1908 and it's family models. All models described on the first page of this report covered by these tests.

3.3 Additional Information Related to Testing

Test results apply only to the particular sample tested and functionality described in this test report.

This report may be reproduced in full. Partial reproduction may only be made with the written permission of the BWS TECH Inc.

4. Description of Tests

4.1 Conducted Emission Measurement

Conducted emissions measurements were made in accordance with section 11, "Measurement of Information Technology Equipment" of ANSI C63.4-2003. The measurement were performed over the frequency range of 0.15MHz to 30MHz using a $50\Omega/50\mu\text{H}$ LISN as the input transducer to a Spectrum Analyzer or a Field Intensity Meter. The measurements were made with the detector set for "Peak" amplitude within an bandwidth of 10KHz or for "quasi-peak" within a bandwidth of 9KHz.

The line-conducted emission test is conducted inside a shielded anechoic chamber room with 1m x 1.5m x 0.8m wooden table which is placed 40cm away from the vertical wall and 1.5m away from the side wall of the chamber room. Two LISNs are bonded to bottom plane of the shielded room. The EUT is powered from the Com-power LISN and the support equipment is powered from the another Com-power LISN. Power to the LISNs is filtered by a noise cut power line filters. All electrical cables are shielded by braided tinned steel tubing with inner ϕ 1.2cm. If the EUT is a DC-powered device, power will be derived from the source power supply it normally will be powered from and these supply lines will be connected to the Com-power LISN. All interconnecting cables more than 1m were shortened by non-inductive bundling (serpentine fashion) to a 1m length. Sufficient time for the EUT, support equipment, and test equipment was allowed in order for them to warm up to their normal operating condition. The RF output of the LISN was connected to the PMM9000 Spectrum Analyzer to determine the frequency producing the max. Emission from the EUT. The frequency producing the max. Level was reexamined using the detector function set to the CISPR Quasi-Peak mode by manual, after scanned by automatic Peak mode from 0.15 to 30MHz. The bandwidth of the Spectrum Analyzer was set to 9kHz. The EUT, support equipment, and interconnecting cables were arranged and manipulated to maximize each emission. Each emission was maximized by switching power lines, varying the mode of operation or resolution, clock or data exchange speed, if applicable, whichever determined the worst-case emission. Each emission reported was calibrated using self-calibrating mode.

Photographs of the worst-case emission can be seen in photographs of conducted emission test setup.

4.2 Radiated Emission Measurement

Preliminary measurements were made at indoors 3 meter semi EMC Anechoic Chamber using broadband antennas, broadband amplifier, and spectrum analyzer to determine the emission frequencies producing the maximum EME.

Appropriate precaution was taken to ensure that all emissions from the EUT were maximized and investigated. The system configuration, mode of operation, turntable azimuth with respect to the antenna were noted for each frequency found. The spectrum was scanned from 30 to 1000MHz using bilog antenna and above 1000MHz, linearly polarized double ridge horn antennas were used. Above 1GHz, linearly polarized double ridge horn antennas were used. The measurements were performed with three frequencies which were selected as bottom, middle and top frequency in the operating band. Emission level from the EUT with various configurations were examined on the spectrum analyzer connected with the RF amplifier and plotted graphically.

Final measurements were made outdoors open site at 3-meter test range using bilog antenna. The output from the antenna was connected, via a pre-selector or a preamplifier, to the input of the EMI Measuring Receiver and Spectrum analyzer(for above 1GHz). The detector function was set to the quasi-peak or peak mode as appropriate. The measurement bandwidth on the Field strength receiver was set to at least 120kHz (1MHz for measurement above 1GHz), with all post-detector filtering no less than 10 times the measurement bandwidth. Sufficient time for the EUT, support equipment, and test equipment was allowed in order for them to warm up to their normal operating condition.

Each frequency found during preliminary measurement was examined and investigated as the same set up and configuration which produced the maximum emission The EUT, support equipment and interconnecting cables were configured to the set-up producing the maximum emission for the frequency and were placed on top of a 0.8-meter high non-metallic 1m x 1.5 meter table. The turntable containing the system was rotated and the antenna height was varied 1 to 4 meters and stopped at the azimuth or height producing the maximum emission.

Each emission was maximized by varying the mode of operating frequencies of the EUT. The system was tested in all the three orthogonal planes and changing the polarity of the antenna. The worst case emissions are recorded in the data tables. If necessary, the radiated emission measurement could be performed at a closer distance to ensure higher accuracy and the results were extrapolated to the specified distance using an inverse linear distance extrapolation factor(20dB/decade) as per section 15.31(f).

Photographs of the worst-case emission test setup can be seen in Appendix 1.

5. Test Condition

5.1 Test Configuration

The device was configured for testing in a typical fashion (as a customer would normally use it). During the tests, the EUT and the supported equipments were installed to meet FCC requirement and operated in a manner which tends to maximize its emission level in a typical application.

Radiated Emission Test

Preliminary radiated emission tests were performed using the procedure in ANSI C63.4/2003 Clause 8.3 to determine the worst operating condition. Final radiated emission tests were conducted at 3 meter open field test site.

5.2 EUT operation

EUT was tested according to the following operation modes provided by the specifications given by the manufacturer, and reported the worst emissions.

Operation Modes	Worst Case Mode
-. Video Resolution 1280x1024, 75 HZ	<input checked="" type="checkbox"/>

Note : Brightness and Contrast was adjusted as maximum level.

5.3 Test System layout on EUT and peripherals

Interface cable _____ Power cable **_____**

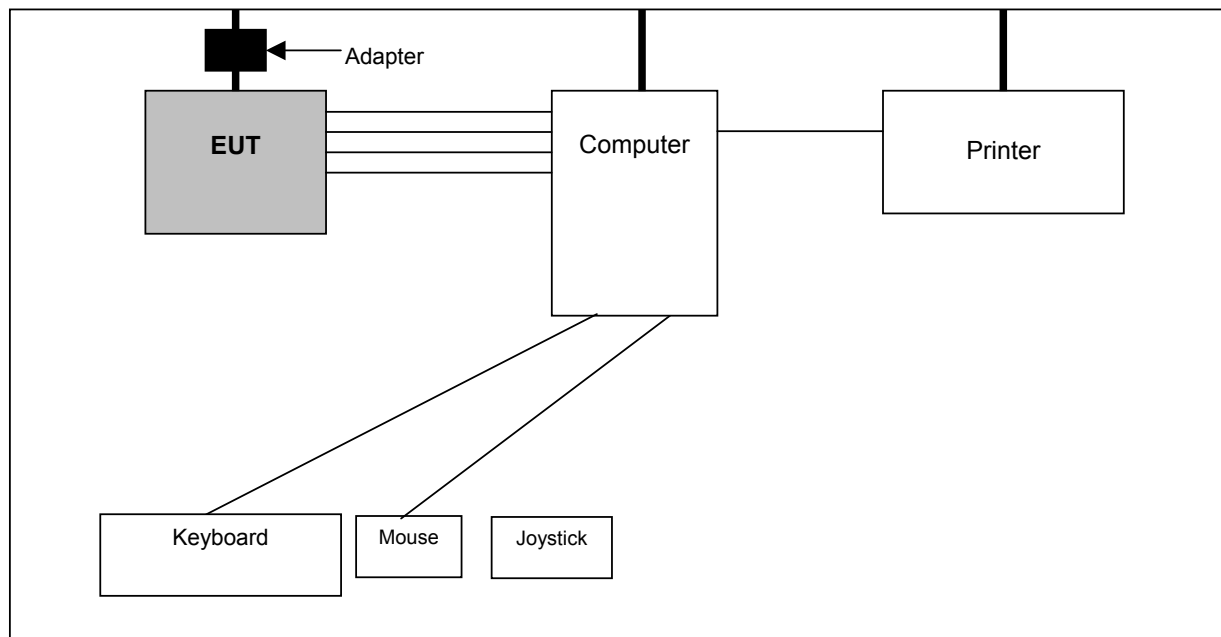

5.4 Peripherals / Support Equipment Used

Following peripheral devices and interface cables were connected during the measurement:

Type of Peripheral Equipment Used:

Description	Model Name	Serial No.	Manufacturer	FCC ID
EUT	AMVX1908	-	D&T Inc.	VYGAMVX1908
Computer	d530CMT	CNG416075J	HP	-
Printer	MJC-650G	H3AH703638	SANSUNG	-
Keyboard	KB-9963	B28AC0NGANB1WH	COMPAQ	-
Mouse	Wheel Mouse 3.0 PS/2 COMPATIBLE	3211626-2	Microsoft	-
Joystick	N/A	S1060030001336	CREATIVE	-

Type of Cables Used:

Device from	Device to	Type of Cable	Length(m)	Type of shield
Computer	Printer	PARALLEL	1.9	Shielded
Computer	Keyboard	PS/2	2.1	Unshielded
Computer	Mouse	PS/2	1.8	Unshielded
Computer	Joystick	USB	1.8	Unshielded
Computer	Power Socket	Inlet	1.5	Unshielded
EUT	Computer	Video	1.5	Shielded
EUT	Computer	DVI	1.5	Shielded
EUT	Computer	S-Video	1.5	Shielded
EUT	Termination	BNC	1.5	Shielded
EUT	Computer	Serial	1.5	Unshielded
EUT	Adapter	Inlet	1.2	Unshielded

6. TEST RESULTS

6.1 Summary of Test Results

The measurement results were obtained with the EUT tested in the conditions described in this report. Detailed measurement data and plots showing the maximum emission of the EUT are reported.

FCC Rule Parts	Measurement Required	Result	EUT Type
15.107(a)	Conducted Emission	Passed by -7.17 dB	LCD Panel :FUJITSU Type: FLC48SXC8V-12F
15.109(a)	Radiated Emissions	Passed by -2.08 dB	
15.107(a)	Conducted Emission	Passed by -7.63 dB	LCD Panel : FUJITSU FLC48SXC8V-11A
15.109(a)	Radiated Emissions	Passed by -2.71 dB	
15.107(a)	Conducted Emission	Passed by -7.73 dB	LCD Panel : NEC NL128102BC29-01
15.109(a)	Radiated Emissions	Passed by -2.76 dB	

The data collected shows that the AMPRONIX INC. 19 Inch TFT LCD Monitor models : AMVX1908 and family models comply with technical requirements of the Part 15.107 and 15.109 of the FCC Rules.

Note : Modification to EUT

The device tested has been made some modification to improve EMI status during a preliminary measurement and applied to the final measurement . The following EMI suppression device(s) was added and/or modified during testing.

1. Added the conductive tape on the contact point between metal shielding enclosures (refer to the page 2 and 14 of appendix 4. Internal photos of EUT)
2. Added the conductive gasket form on the rear side of LCD panel (refer to the page 1 of appendix 4. Internal photos of EUT)
3. Added the ferrite ring core on the data cable (refer to the page 3 of appendix 4. Internal photos of EUT)

6.2 Conducted Emissions

EUT : 19 Inch LCD Monitor AMVX1908 (LCD Panel :FUJITSU, FLC48SXC8V-12F)
 Limit apply to : FCC Part15 Subpart B Class B Section 15.107(a)
 Test Date : July 19, 2005
 Operating Condition : "H" pattern display mode
 Environment Condition : Humidity Level : 45 %RH, Temperature : 25 °C
 Result : Passed by -7.17 dB

The following table shows the highest levels of conducted emissions on both phase of Hot and Neutral line.

Tabulated Conducted Emission Test Data

Detector Mode ; CISPR Quasi Peak mode (6dB Bandwidth : 9kHz).

Freq [MHz]	Correcton		Phase [H/N]	Quasi-Peak Mode				Average Mode			
	AMN	C.L		Lim it	Reading	Emission	Margin	Lim it	Reading	Emission Level	Margin
				[dBuV]	[dBuV]	[dBuV]	[dBuV]	[dBuV]	[dBuV]	[dBuV]	[dBuV]
0.150	0.06	0.03	H	66.00	54.90	54.99	-11.01	56.00	29.10	29.19	-26.81
0.159	0.06	0.03	H	65.90	53.20	53.29	-12.61	55.90	28.20	28.29	-27.61
0.168	0.06	0.03	H	65.60	52.20	52.29	-13.31	55.60	28.50	28.59	-27.01
0.192	0.06	0.03	N	64.90	53.20	53.29	-11.61	54.90	46.80	46.89	-8.01
0.391	0.08	0.24	H	59.10	45.30	45.62	-13.48	49.10	42.30	42.62	-6.48
0.488	0.07	0.28	H	56.40	44.00	44.35	-12.05	46.40	42.30	42.65	-3.75
0.684	0.07	0.30	H	56.00	46.20	46.57	-9.43	46.00	44.00	44.37	-1.63
0.780	0.08	0.30	H		45.70	46.08	-9.92		42.80	43.18	-2.82
0.975	0.04	0.38	H		45.80	46.22	-9.78		42.80	43.22	-2.78
1.268	0.04	0.44	H		46.10	46.58	-9.42		44.00	44.48	-1.52
1.560	0.03	0.48	H		45.50	46.01	-9.99		44.00	44.51	-1.49
3.610	0.03	0.70	H		48.10	48.83	-7.17		41.60	42.33	-3.67
5.370	0.05	0.88	H	60.00	39.70	40.63	-19.37	50.00			
5.680	0.06	0.89	N		40.70	41.65	-18.35				
6.150	0.06	0.91	H		40.70	41.67	-18.33				
6.540	0.04	0.93	H		39.20	40.17	-19.83				
24.880	0.10	1.48	H		38.90	40.48	-19.52				
28.530	0.23	1.61	H		39.00	40.84	-19.16				

NOTES :

1. H : Hot Line , N :Neutral Line
2. Emission Level = Reading + Correction Factor
3. Margin = Emission Level - Limit



Tested by Kim, Jin-Seok

EUT : 19 Inch LCD Monitor AMVX1908 (LCD Panel :FUJITSU, FLC48SXC8V-11A)
 Limit apply to : FCC Part15 Subpart B Class B Section 15.107(a)
 Test Date : July 19, 2005
 Operating Condition : "H" pattern display mode
 Environment Condition : Humidity Level : 48 %RH, Temperature : 25 °C
 Result : Passed by -7.63 dB

The following table shows the highest levels of conducted emissions on both phase of Hot and Neutral line.

Tabulated Conducted Emission Test Data

Detector Mode ; CISPR Quasi Peak mode (6dB Bandwidth : 9kHz).

Freq [MHz]	Correcton		Phase [H/N]	Quasi-Peak Mode				Average Mode			
	AMN	C.L		Lim it	Reading	Emission Level	Margin	Lim it	Reading	Emission Level	Margin
0.153	0.06	0.03	N	66.00	53.40	53.49	-12.51	56.00	23.60	23.69	-32.31
0.157	0.06	0.03	N	65.90	52.00	52.09	-13.81	55.90	21.00	21.09	-34.81
0.170	0.06	0.03	N	65.40	51.30	51.39	-14.01	55.40	20.10	20.19	-35.21
0.176	0.06	0.03	N	65.30	49.60	49.69	-15.61	55.30	24.10	24.19	-31.11
0.201	0.07	0.10	H	64.60	56.80	56.97	-7.63	54.60	50.90	51.07	-3.53
0.402	0.08	0.26	H	58.90	45.40	45.74	-13.16	48.90	42.40	42.74	-6.16
0.501	0.07	0.30	H	56.00	44.70	45.07	-10.93	46.00	42.90	43.27	-2.73
0.802	0.08	0.30	H		45.10	45.48	-10.52		42.70	43.08	-2.92
1.003	0.04	0.40	H		46.30	46.74	-9.26		42.20	42.64	-3.36
1.405	0.03	0.46	H		45.90	46.39	-9.61		43.40	43.89	-2.11
2.008	0.03	0.55	H		46.70	47.28	-8.72		41.40	41.98	-4.02
3.817	0.03	0.74	H		47.00	47.77	-8.23		42.60	43.37	-2.63
5.830	0.06	0.89	H	60.00	41.00	41.95	-18.05	50.00			
6.130	0.06	0.91	H		42.10	43.07	-16.93				
6.430	0.05	0.93	H		42.60	43.58	-16.42				
6.730	0.04	0.95	H		42.60	43.59	-16.41				
7.130	0.03	0.97	H		41.50	42.50	-17.50				
29.150	0.25	1.64	H		37.30	39.19	-20.81				

NOTES :

4. H : Hot Line , N :Neutral Line
5. Emission Level = Reading + Correction Factor
6. Margin = Emission Level - Limit



Tested by Kim, Jin-Seok

EUT : 19 Inch LCD Monitor AMVX1908 (LCD Panel : NEC, NL128102BC29-01)
 Limit apply to : FCC Part15 Subpart B Class B Section 15.107(a)
 Test Date : July 18, 2005
 Operating Condition : "H" pattern display mode
 Environment Condition : Humidity Level : 50 %RH, Temperature : 25 °C
 Result : Passed by -7.73 dB

The following table shows the highest levels of conducted emissions on both phase of Hot and Neutral line.

Tabulated Conducted Emission Test Data

Detector Mode ; CISPR Quasi Peak mode (6dB Bandwidth : 9kHz).

Freq [MHz]	Correcton		Phase [H/N]	Quasi-Peak Mode				Average Mode			
	AMN	C.L		Lim it	Reading	Emission Level	Margin	Lim it	Reading	Emission Level	Margin
0.151	0.06	0.03	N	66.00	53.10	53.19	-12.81	56.00	32.10	32.19	-23.81
0.161	0.06	0.03	N	65.70	51.40	51.49	-14.21	55.70	24.70	24.79	-30.91
0.168	0.06	0.03	N	65.60	49.90	49.99	-15.61	55.60	20.80	20.89	-34.71
0.200	0.07	0.10	H	64.60	56.70	56.87	-7.73	54.60	50.70	50.87	-3.73
0.301	0.08	0.22	N	61.70	42.90	43.20	-18.50	51.70	28.10	28.40	-23.30
0.402	0.08	0.26	H	58.90	44.80	45.14	-13.76	48.90	42.50	42.84	-6.06
0.502	0.07	0.30	H	56.00	45.30	45.67	-10.33	46.00	43.00	43.37	-2.63
0.804	0.08	0.30	H		45.30	45.68	-10.32		43.00	43.38	-2.62
1.106	0.04	0.42	H		45.80	46.26	-9.74		43.60	44.06	-1.94
1.409	0.03	0.46	H		45.90	46.39	-9.61		43.70	44.19	-1.81
1.711	0.03	0.51	H		46.40	46.94	-9.06		42.80	43.34	-2.66
3.825	0.03	0.74	H		46.50	47.27	-8.73		40.80	41.57	-4.43
5.140	0.05	0.87	H	60.00	38.90	39.82	-20.18	50.00			
5.540	0.05	0.88	H		37.60	38.53	-21.47				
5.840	0.06	0.89	H		39.60	40.55	-19.45				
6.550	0.04	0.94	H		39.60	40.58	-19.42				
6.850	0.03	0.96	H		39.50	40.49	-19.51				
28.120	0.22	1.60	H		39.10	40.92	-19.08				

NOTES :

- 7. H : Hot Line , N :Neutral Line
- 8. Emission Level = Reading + Correction Factor
- 9. Margin = Emission Level - Limit



Tested by Kim, Jin-Seok

6.3 Radiated Emissions

EUT : 19 Inch LCD Monitor AMVX1908 (LCD Panel :FUJITSU, FLC48SXC8V-12F)
 Limit apply to : FCC Part15 Subpart B Class B Section 15.109(a)
 Test Date : July 19, 2005
 Operating Condition : “H” pattern display mode
 Environment Condition : Humidity Level : 47 %RH, Temperature : 26 °C
 Result : Passed by -2.08 dB

Radiated Emission Test Data

The following table shows the highest levels of radiated emissions on both polarization of horizontal and vertical.

Detector mode : CISPR Quasi-Peak mode (6dB Bandwidth : 120 kHz)

Measurement Distance : 3 meters

Frequency [MHz]	Reading [dB μ V]	Polarization [*H/**V]	Ant.Factor [dB]	Cable Loss [dB]	Limit [dB μ V/m]	Emission Level [dB μ V/m]	Margin [dB]
35.08	18.91	V	12.00	1.33	40.00	32.25	-7.75
57.46	16.12	V	12.24	1.71	40.00	30.08	-9.92
80.48	24.66	V	8.39	1.97	40.00	35.02	-4.98
182.50	17.63	H	11.79	3.00	43.50	32.42	-11.08
210.06	16.59	H	10.24	3.22	43.50	30.05	-13.45
217.45	21.15	H	10.33	3.28	46.00	34.76	-11.24
326.00	25.57	H	14.03	4.02	46.00	43.62	-2.38
378.74	22.80	H	15.28	4.38	46.00	42.46	-3.54
380.43	24.20	H	15.32	4.39	46.00	43.92	-2.08
597.62	15.34	H	19.83	5.57	46.00	40.74	-5.26
787.06	11.85	V	22.53	6.67	46.00	41.05	-4.95
977.90	11.52	H	24.39	7.53	53.97	43.45	-10.52

NOTES :

- * H : Horizontal polarization , ** V : Vertical polarization
- Emission Level = Reading + Antenna factor + Cable loss
- Margin value = Emission Level - Limit
- All other emissions not reported were more than 25dB below the permitted limit.



Tested by Kim, Jin-Seok

EUT : 19 Inch LCD Monitor AMVX1908 (LCD Panel :FUJITSU, FLC48SXC8V-11A)
 Limit apply to : FCC Part15 Subpart B Class B Section 15.109(a)
 Test Date : July 19, 2005
 Operating Condition : "H" pattern display mode
 Environment Condition : Humidity Level : 45 %RH, Temperature : 33 °C
 Result : Passed by -2.71 dB

Radiated Emission Test Data

The following table shows the highest levels of radiated emissions on both polarization of horizontal and vertical.

Detector mode : CISPR Quasi-Peak mode (6dB Bandwidth : 120 kHz)

Measurement Distance : 3 meters

Frequency [MHz]	Reading [dB μ V]	Polarization [*H/**V]	Ant.Factor [dB]	Cable Loss [dB]	Limit [dB μ V/m]	Emission Level [dB μ V/m]	Margin 04 [dB]
30.62	21.04	V	11.86	1.24	40.00	34.14	-5.86
69.48	21.83	V	10.68	1.84	40.00	34.34	-5.66
80.47	25.54	V	8.39	1.97	40.00	35.90	-4.10
180.51	14.35	V	11.98	2.98	43.50	29.32	-14.18
210.45	15.28	H	10.25	3.23	43.50	28.75	-14.75
217.34	22.60	H	10.33	3.27	46.00	36.20	-9.80
326.01	23.03	H	14.03	4.02	46.00	41.08	-4.92
360.91	22.84	H	14.86	4.24	46.00	41.94	-4.06
380.36	23.57	H	15.32	4.39	46.00	43.29	-2.71
434.70	17.26	H	16.57	4.70	46.00	38.54	-7.46
760.57	11.66	H	22.29	6.55	46.00	40.50	-5.50
977.90	11.17	H	24.39	7.53	53.97	43.10	-10.87

NOTES :

5. * H : Horizontal polarization , ** V : Vertical polarization
6. Emission Level = Reading + Antenna factor + Cable loss
7. Margin value = Emission Level - Limit
8. All other emissions not reported were more than 25dB below the permitted limit.



Tested by Kim, Jin-Seok

EUT : 19 Inch LCD Monitor AMVX1908 (LCD Panel : NEC, NL128102BC29-01)
 Limit apply to : FCC Part15 Subpart B Class B Section 15.109(a)
 Test Date : July 18, 2005
 Operating Condition : "H" pattern display mode
 Environment Condition : Humidity Level : 50 %RH, Temperature : 25 °C
 Result : Passed by -2.76 dB

Radiated Emission Test Data

The following table shows the highest levels of radiated emissions on both polarization of horizontal and vertical.

Detector mode : CISPR Quasi-Peak mode (6dB Bandwidth : 120 kHz)

Measurement Distance : 3 meters

Frequency [MHz]	Reading [dB μ V]	Polarization [*H/**V]	Ant.Factor [dB]	Cable Loss [dB]	Limit [dB μ V/m]	Emission Level [dB μ V/m]	Margin 04 [dB]
43.33	16.73	V	12.33	1.48	40.00	30.54	-9.46
67.80	22.02	V	10.96	1.82	40.00	34.80	-5.20
108.73	20.23	V	10.62	2.29	43.50	33.14	-10.36
135.78	18.63	V	12.68	2.56	43.50	33.86	-9.64
163.08	14.56	V	13.26	2.84	43.50	30.65	-12.85
217.38	19.10	H	10.33	3.28	46.00	32.70	-13.30
434.70	19.64	H	16.57	4.70	46.00	40.92	-5.08
488.98	18.87	H	17.51	5.02	46.00	41.40	-4.60
543.18	19.44	V	18.49	5.31	46.00	43.24	-2.76
597.60	15.40	H	19.83	5.57	46.00	40.80	-5.20
649.35	15.02	H	20.36	5.87	46.00	41.25	-4.75
760.58	13.32	H	22.29	6.55	46.00	42.16	-3.84

NOTES :

9. * H : Horizontal polarization , ** V : Vertical polarization
10. Emission Level = Reading + Antenna factor + Cable loss
11. Margin value = Emission Level - Limit
12. All other emissions not reported were more than 25dB below the permitted limit.



Tested by Kim, Jin-Seok

Plots of Conducted Emission Test (LCD Panel :FUJITSU, FLC48SXC8V-12F)

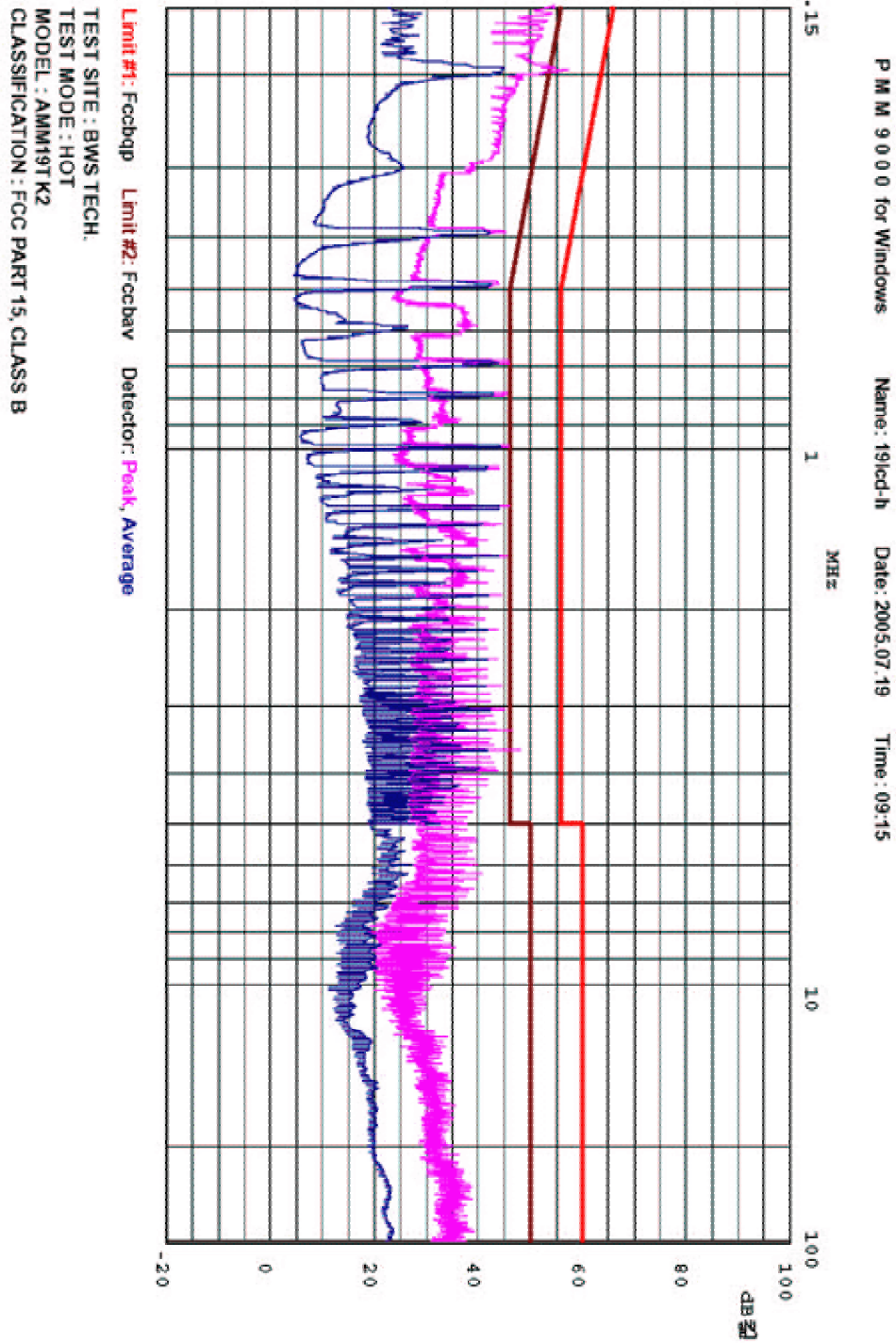

Plots of Conducted Emission Test (LCD Panel :FUJITSU, FLC48SXC8V-12F)

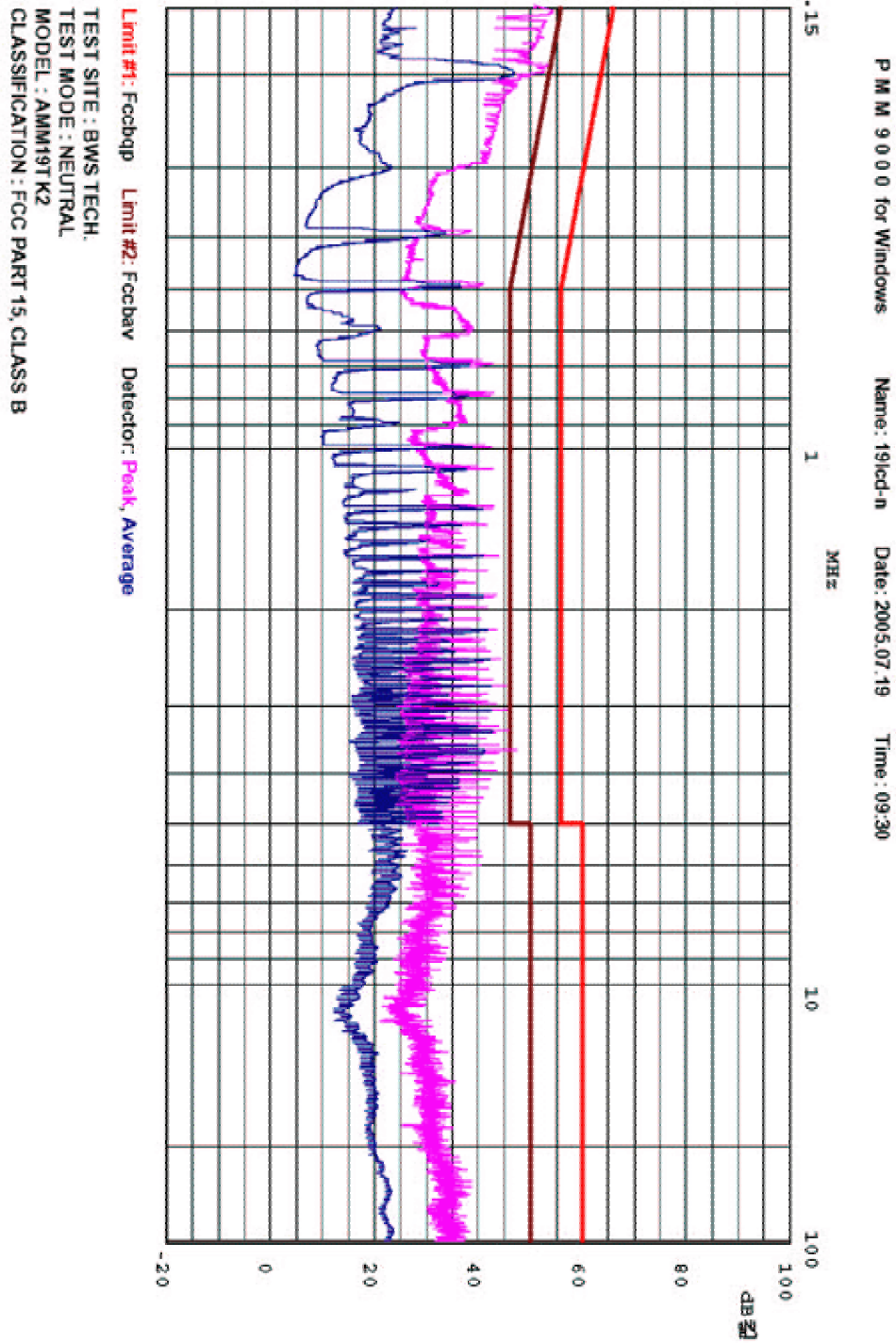

Plots of Conducted Emission Test (LCD Panel :FUJITSU,FLC48SXC8V-11A)

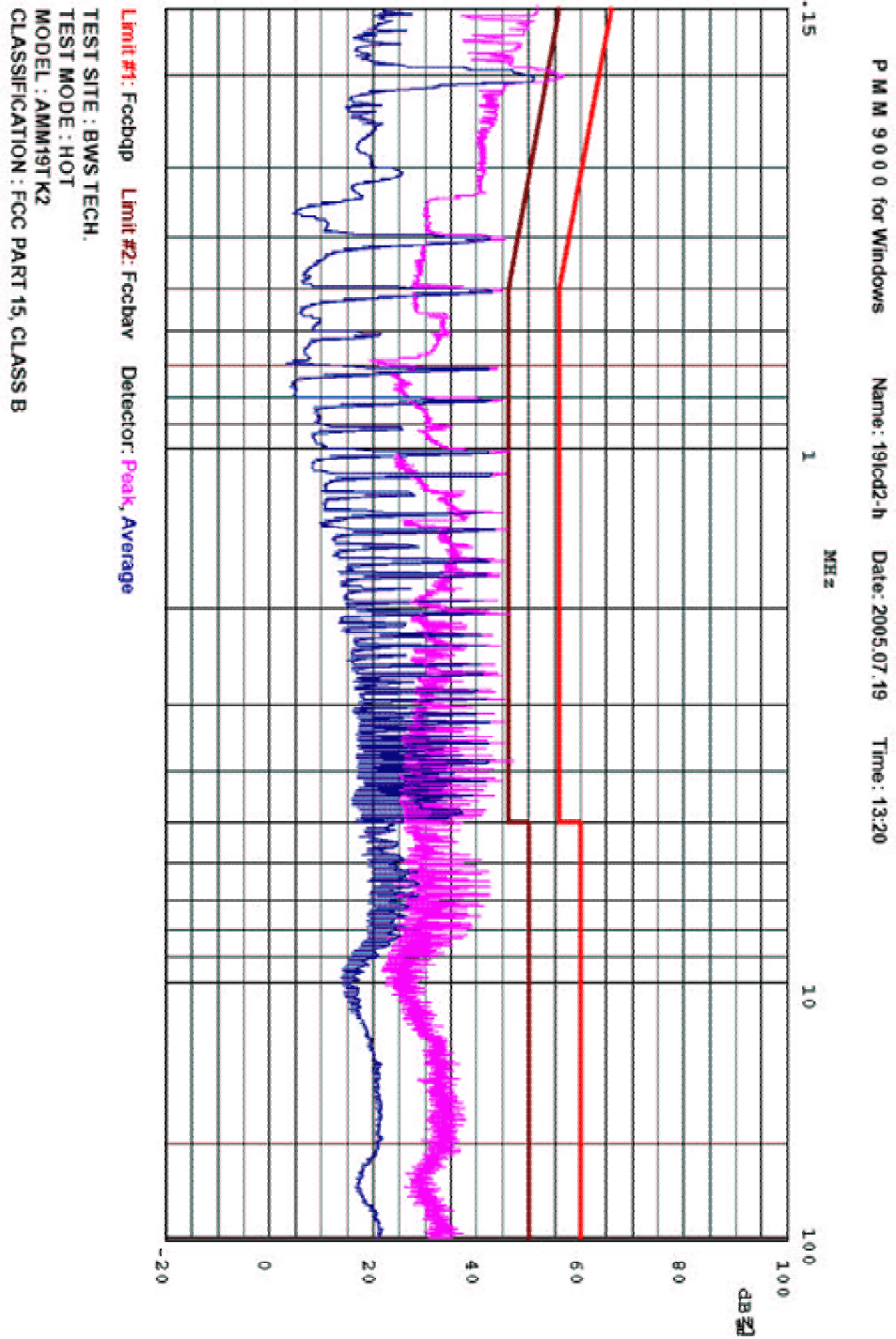

Plots of Conducted Emission Test (LCD Panel :FUJITSU,FLC48SXC8V-11A)

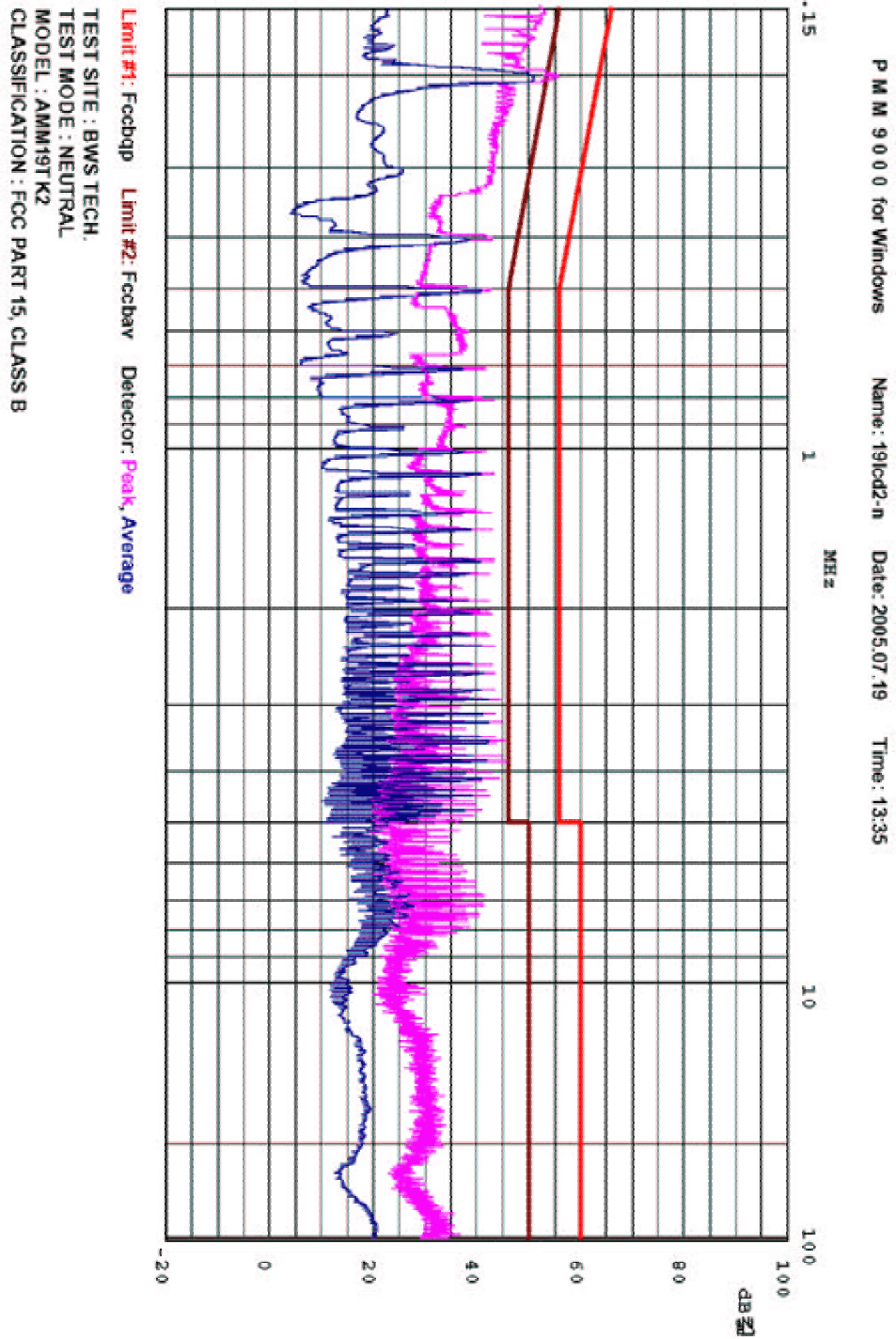

Plots of Conducted Emission Test (LCD Panel : NEC, NL128102BC29-01)

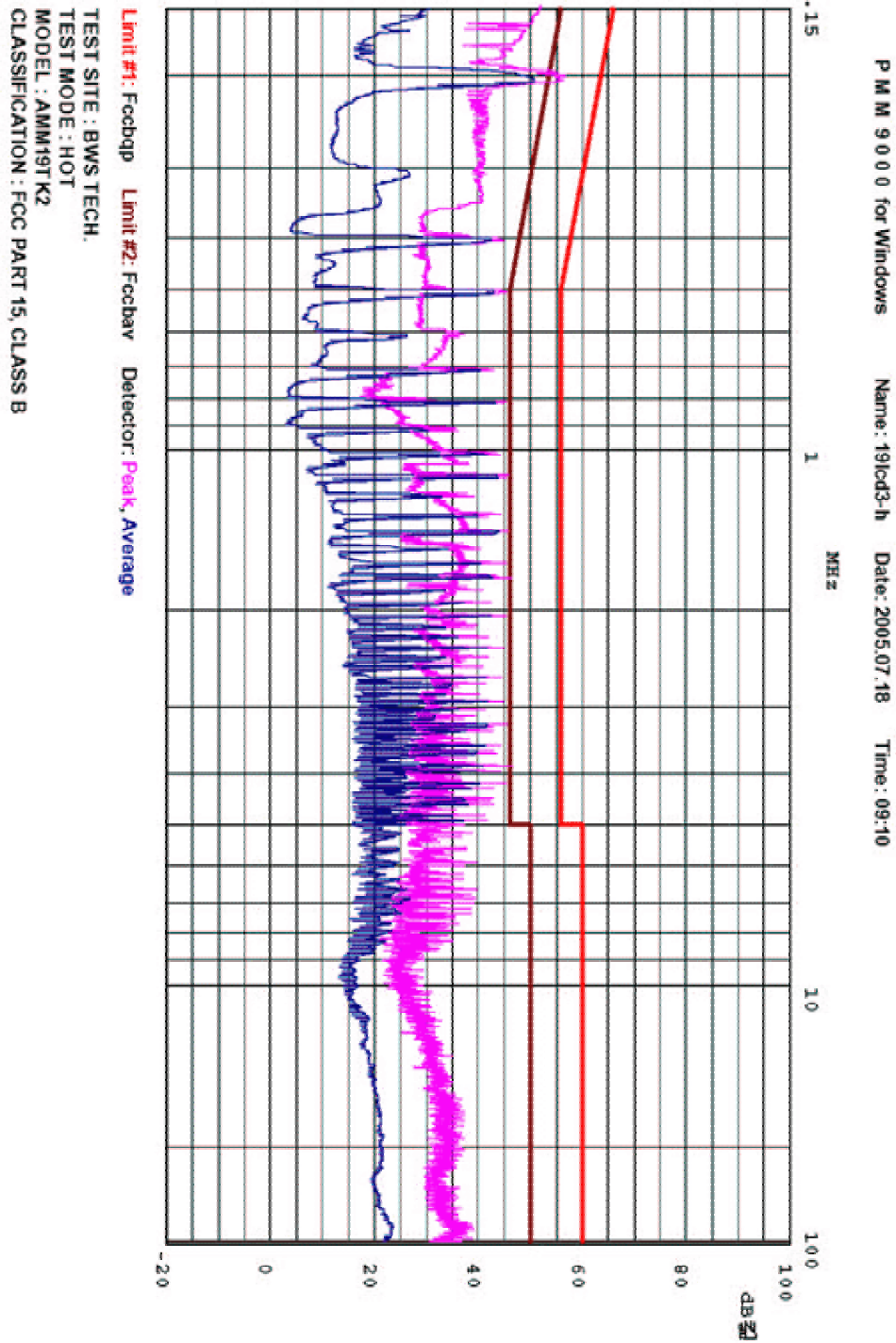

Plots of Conducted Emission Test (LCD Panel : NEC, NL128102BC29-01)

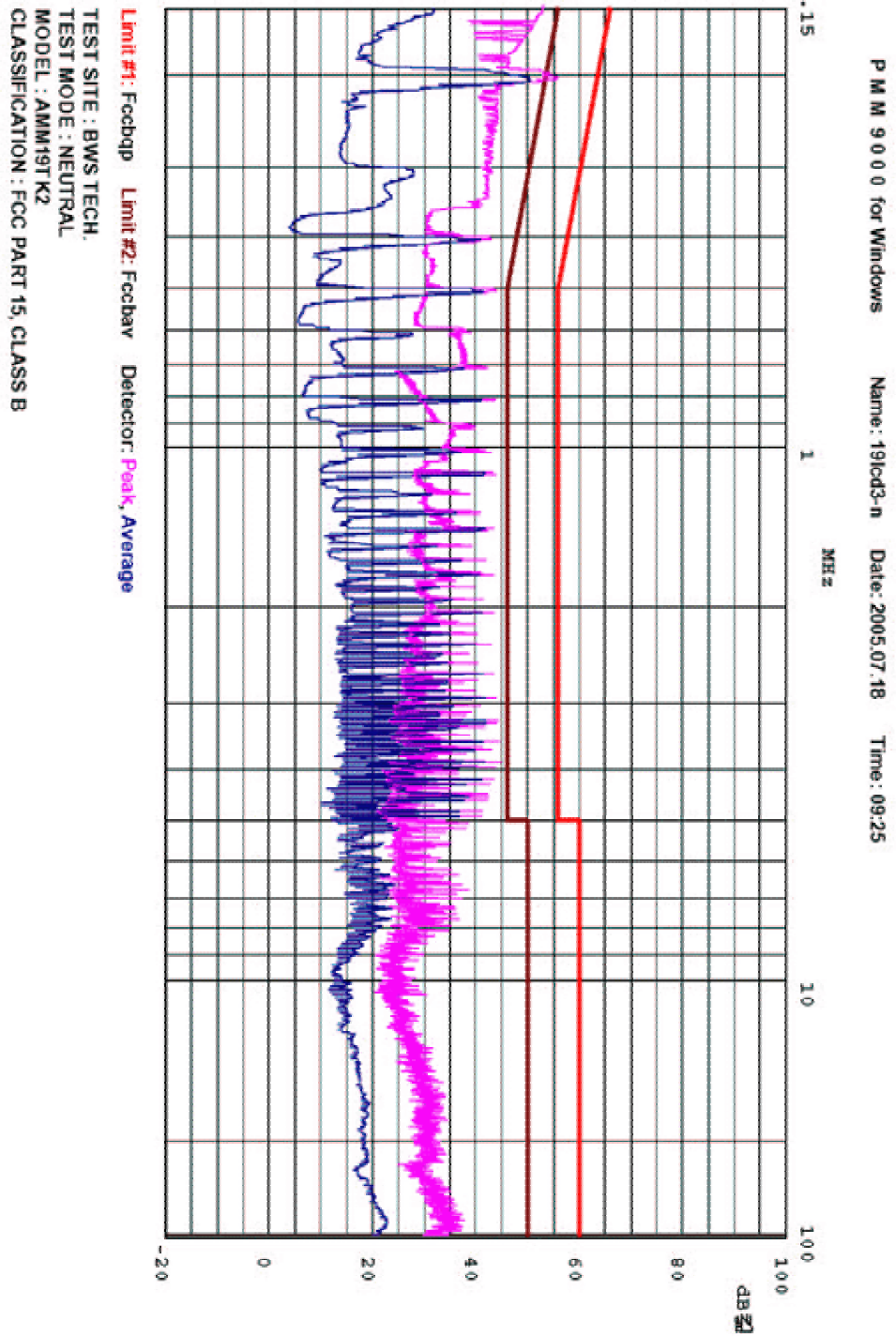

7. Sample Calculation and Other Information

7.1 Sample Calculations

$$\text{dB}\mu\text{V} = 20 \log_{10} (\mu\text{V}/\text{m})$$

$$\mu\text{V} = 10^{(\text{dB}\mu\text{V}/20)}$$

EX. 1.

@ 3.610 MHz Class B limit(Quasi-peak) = 56.00 dB μ V

Reading = 48.10 dB μ V (calibrated level)

AMN factor + Cable Loss = 0.73 dB

Total = 48.83 dB μ V/m

Margin = 48.83 - 56.00 = -7.17

7.17 dB ; below limit

EX. 2.

@ 380.43 MHz Class B limit = 46.00 dB μ V/m

Reading = 24.20 dB μ V(calibrated level)

Antenna factor + Cable Loss = 19.72 dB

Total = 43.92 dB μ V/m

$10^{(43.12/20)} = \mu\text{V}/\text{m}$

Margin = 43.92 - 46.00 = -2.08 dB

2.08 dB ; below limit

7.2. Measurement Uncertainty

Measurement uncertainty of RFI Voltage Measurement test was estimated at ± 3.51 dB(k=2).

Measurement uncertainty of RFI Field Strength Measurement test was estimated at ± 4.34 dB (k=2).

8. TEST EQUIPMENTS LIST

The listing below denotes the test equipments utilized for the test(s).

Equipment Type	Model	Manufacture	Serial No	Cal Due Date	Use
Signal Analyzer	PMM9000	PMM	3100570602	05. 31. 2006	<input checked="" type="checkbox"/>
EMI Receiver	ESVS 10	ROHDE & SCHWARZ	863247/019	05. 25. 2006	<input checked="" type="checkbox"/>
Conducted Cable	CC-10	N/A	BWS-02	N/A	<input checked="" type="checkbox"/>
LISN Multiline	L1-115	Com-Power	241017	10. 27. 2005	<input checked="" type="checkbox"/>
LISN Multiline	L1-115	Com-Power	241018	10. 27. 2005	<input checked="" type="checkbox"/>
Bilog Antenna	VULB 9160	SCHWARZBECK	9160-3052	03. 18. 2006	<input checked="" type="checkbox"/>
Open Site Cable	OSC-30	N/A	BWS-01	N/A	<input checked="" type="checkbox"/>
Antenna Mast	JAC-3	DAIL EMC	N/A	N/A	<input checked="" type="checkbox"/>
Antenna Turntable Controller	JAC-2	JAEMC	N/A	N/A	<input checked="" type="checkbox"/>