

---

**Electromagnetic Emission**  
**FCC MEASUREMENT REPORT**  
**CERTIFICATION OF COMPLIANCE**  
**FCC Part 15 Certification Measurement**

---

**PRODUCT** : Radar detector  
**MODEL/Serial No.** : B-01-01 / Proto-type  
**FCC ID** : VVV-B-01-01  
**BRAND NAME** :   
**APPLICANT** : Adaptiv Technologies, LLC  
1639 11th Street, Suite 156, Santa Monica, CA 90404, U.S.A.  
Attn. : Adam Gold / Director  
**MANUFACTURER** : Willtronics Co., Ltd  
301 Kwanlidong, KwangMyung Industrial Complex, 201 Haan-3-Dong,  
KwangMyung, Kyungki, Korea, 423-063  
**FCC CLASSIFICATION** : Unintentional Radiators  
CRD - Part 15 Radar Detector  
**RULE PART(S)** : FCC Part 15 Subpart B  
**FCC PROCEDURE** : ANSI C63.4-2003  
**TEST REPORT No.** : ETLE100118.03  
**DATES OF TEST** : January 25, 2010  
**REPORT ISSUE DATE** : January 28, 2010  
**TEST LABORATORY** : ETL Inc. (FCC Designation Number : KR0022)

This Radar detector, Model B-01-01 has been tested in accordance with the measurement procedures specified in ANSI C63.4-2003 at the ETL Test Laboratory and has been shown to be complied with the electromagnetic radiated emission limits specified in FCC Rule Part15 Subpart B:

I attest to the accuracy of data. All measurement herein was performed by me or was made under my supervision and is correct to the best of my knowledge and belief. I assume full responsibility for the completeness of these measurements and vouch for the qualifications of all persons taking them.

The results of testing in this report apply to the product/system which was tested only. Other similar equipment will not necessarily produce the same results due to production tolerance and measurement uncertainties.



---

Yo Han, Park / Chief Engineer

**ETL Inc.**  
**#371-51, Gasan-dong, Geumcheon-gu, Seoul, 153-803, Korea**  
**Tel: 82-2-858-0786 Fax: 82-2-858-0788**

## Table of Contents

### FCC Measurement Report

1. Introduction
2. Product Information
3. Description of Tests
4. Test Condition
5. Test Results
  - 5.1 Summary of Test Results
  - 5.2 Radiated Emissions Measurement
6. Sample Calculation
7. List of test Equipment used for Measurement

Appendix A. FCC ID Label and Location

Appendix B. Test Setup Photographs

Appendix C. External Photographs

Appendix D. Internal Photographs

Appendix E. Block Diagram

Appendix F. Operating Description and specifications

Appendix G. User Manual

Appendix H. Schematic

## FCC MEASUREMENT REPORT

**Scope** – Measurement and determination of electromagnetic emission(EME) of radio frequency devices including intentional radiators and/or unintentional radiators for compliance with the technical rules and regulations of the U.S Federal Communications Commission(FCC)

### General Information

<b>Applicant Name</b>	: Adaptiv Technologies, LLC
<b>Address</b>	: 1639 11th Street, Suite 156, Santa Monica, CA 90404, U.S.A.
<b>Attention</b>	: Adam Gold / Director

- **EUT Type :** Radar detector
- **Model Number :** B-01-01
- **FCC ID :** VWV-B-01-01
- **S/N :** Proto-type
- **Frequency Range :** NONE
- **FCC Rule Part(s) :** FCC Part 15 Subpart B
- **Test Procedure :** ANSI C63.4-2003
- **FCC Classification :** Unintentional Radiators  
CRD - Part 15 Radar Detector
- **Dates of Tests :** January 25, 2010
- **Place of Tests :** ETL Inc. Testing Lab.  
  
Radiated Emission test;  
#499-1, Sagot-ri, Seosin-myeon, Hwaseong-si,  
Gyeonggi-do, 445-882, Korea  
  
Conducted Emission test;  
ETL Inc. Testing Lab.  
371-51, Gasan-dong, Geumcheon-gu, Seoul, 153-803, Korea
- **Test Report No. :** ETLE100118.03

## **1. INTRODUCTION**

The measurement test for radiated and conducted emission test were conducted at the ETL Inc. The site is constructed in conformance with the requirements of the ANSI C63.4-2003 and CISPR Publication 16. The ETL has site descriptions on file with the FCC for 3 m and 10 m site configurations. Detailed description of test facility was found to be in compliance with FCC Rules according to the ANSI C63.4-2003 and registered to the Federal Communications Commission (FCC Designation Number : KR0022).

The measurement procedure described in American National Standard for Method of Measurement of Radio-Noise Emission from Low-Voltage Electrical and Electronic Equipment in the Range of 9 kHz to 40 GHz (ANSI C63.4-2003) was used in determining radiated and conducted emissions from the Adaptiv Technologies, LLC Model: B-01-01

## 2. PRODUCT INFORMATION

### 2.1 Equipment Description

The Equipment Under Test (EUT) is the Radar detector (model: B-01-01).

### 2.2 General Specification

General		
Dimensions	65 mm (W) x 118 mm (L) x 42 mm (H)	
Weight	185 g	
Power Requirement	CAR Battery 12 V DC	
Temperature Range	Operating	-20 °C to +80 °C
	Storage	-40 °C to +100 °C
Laser Detector		
Receiver Type	Pulse Laser Signal Receiver	
Sensor Front End	Convex Condenser Lens	
Detector Type	Pulse Width Discriminator	
Receiver Bandwidth	30 MHz	
Spectral Response	800 nm – 1 100 nm	
Radar Detector		
Receiver Type	Double Conversion Super heterodyne	
Detector Type	Scanning Frequency Discriminator	
Antenna Type	Linear Polarization	
Frequency of Operation	10.525 GHz (X Band)	
	24.150 GHz (K Band)	
	34.700 GHz (Ka Band)	

## 3. DESCRIPTION OF TESTS

### 3.1 Radiated Emission Measurement

Radiated emission measurements were made in accordance with section 12, "Measurement of unintentional radiators other than ITE" of ANSI C63.4-2003. The measurements were performed over the frequency range of 11.7 GHz to 12.2 GHz using antenna as the input transducer to a spectrum analyzer. The measurements were made with the detector set for "peak" within a bandwidth of 1 MHz.

Preliminary measurements were made at 3 m using broadband antennas, and spectrum analyzer to determine the frequency producing the maximum emission in shielded room. Appropriate precaution was taken to ensure that all emission from the EUT were maximized and investigated. The system configuration, mode of operation, turntable azimuth and height with respect to the antenna were noted for each frequency found. The spectrum was scanned from Above 1 GHz; linearly polarized double ridge horn antennas were used. Final measurements were made open site at 3 m. A search was made of spectrum from 11.7 GHz to 12.2 GHz the measurements indicate that the unit meets the FCC requirements. Measurements in the 11.7 GHz to 12.2 GHz band were made with a Standard Gain Horn. The measurements in the 11.7 GHz to 12.2 GHz band represent the ambient noise levels. The attached plots were made with peak detector with the analyzer in a maximum hold for 2 minutes. The test equipment was laced on a wooden turn-table. Sufficient time for the EUT, support equipment, and test equipment was allowed in order for them to warm up to their normal operating condition. Each frequency found during pre-scan measurements was re-examined by manual. The detector function was set to CISPR Quasi-peak mode and the bandwidth of the receiver was set to 120 kHz or 1 MHz depending on the frequency of type of signal. The EUT, support equipment and interconnecting cables were re-configured to the set-up producing the maximum emission for the frequency and were placed on top of a 0.8 m high nonmetallic 1 m x 1.5 m table. The EUT, support equipment, and interconnecting cables were re-arranged and manipulated to maximize each emission. The turntable containing the system was rotated; the antenna height was varied 1 m to 4 m and stopped at the azimuth or height producing the maximum emission. Each emission was maximized by: varying the mode of operation to the EUT and/or support equipment and changing the polarity of the antenna, whichever determined the worst-case emission.

Photographs of the worst-case emission can be seen in Photographs of the worst-case emission test setup can be seen in Appendix B.

## 4. TEST CONDITION

### 4.1 Test Configuration

The device was configured for testing in a typical fashion (as a customer would normally use it). During the tests, the EUT and the supported equipments were installed to meet FCC requirement and operated in a manner and which tends to maximize its emission level in a typical application.

### 4.2 EUT operation

- The EUT was connected as user's guide. And during the test executed EUT is operating on the following:  
Band: 10.525 GHz (X Band); 24.150 GHz (K Band); 34.700 GHz (Ka Band)

Operating Mode
Stand-by mode
10.525 GHz (X Band)
24.150 GHz (K Band)
34.700 GHz (Ka Band)

### 4.3 Support Equipment Used

Description	Model Name	Serial No.	Manufacturer
Laser Receiver	WL-1000	3E 01740	NONE
Laser Generator	NONE	NONE	NONE
Car Battery	NONE	NONE	NONE

### 4.4 Type of Cables Used

Device from	Device to	Type of I/O port	Length[m]	Type of shield
EUT	Laser Receiver	Line	2.0	Unshielded
EUT	Car Battery	DC Input	1.2	Unshielded

## 4.5 The setup drawing(s)

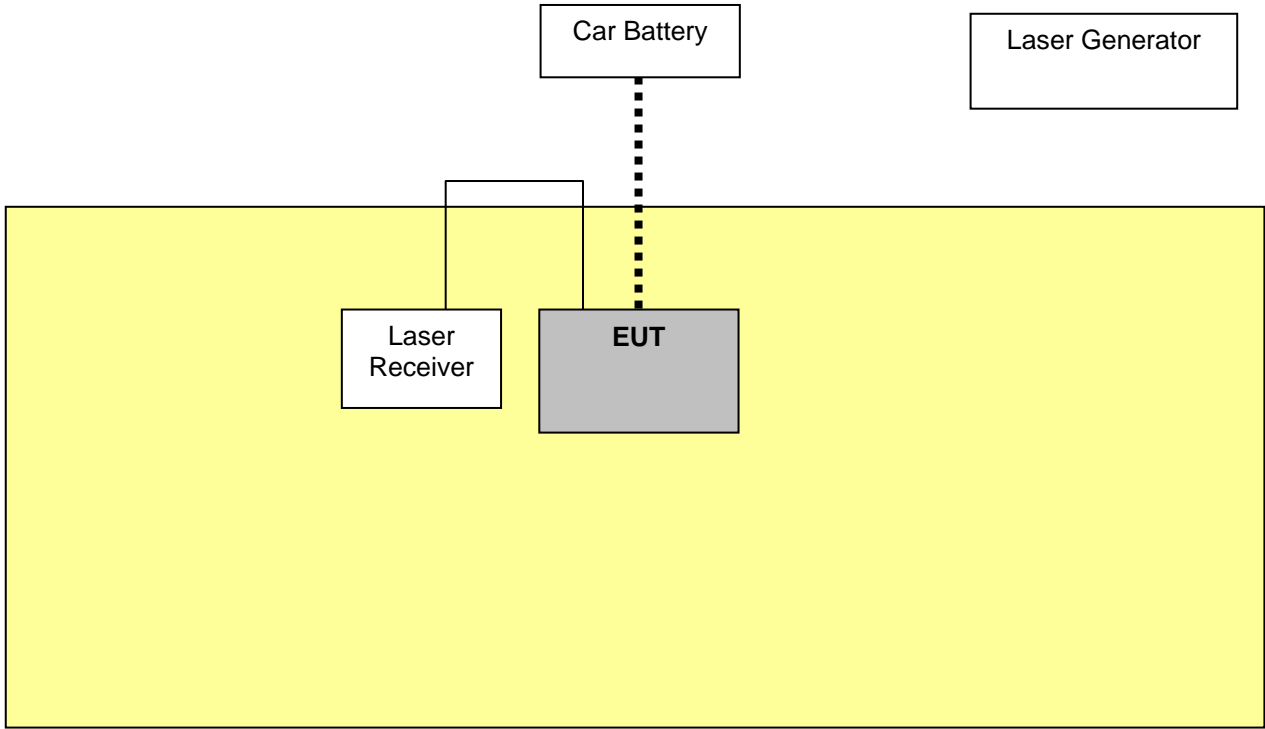

- : Data Line
- ..... : DC Power Line
- : AC Power Line



## 5. TEST RESULTS

### 5.1 Summary of Test Results

The measurement results were obtained with the EUT tested in the conditions described in this report. Detailed measurement data and plots showing the maximum emission of the EUT are reported.

FCC Rule	Measurement Required	Result
15.109(h)	Radiated Emission Measurement	<b>No Signal Detected</b>

The data collected shows that the **Adaptiv Technologies, LLC / Radar detector / B-01-01** complied with technical requirements of above rules part 15.109(h).

The equipment is modified anything, mechanical or circuits to improve EMI status during a measurement. EMI suppression device(s) was added and/or modified during testing.

## 5.2 Radiated Emissions Measurement

EUT	Radar detector / B-01-01 (S/N: Proto-type)
Limit apply to	FCC Part 15.109(h)
Test Date	January 25, 2010
Operating Condition	Operating on the following Bands (X, K, Ka, Laser bands) and There are two mode (i) City Mode (ii) Highway Mode
Result	Passed

### Radiated Emission Test Data

The following table shows the highest levels of radiated emissions on both polarizations of horizontal and vertical.  
Detector mode: Peak mode (Bandwidth: 1 MHz)

Frequency [MHz]	Reading [dB( $\mu$ V)]	Polarization (*H/**V)	Ant. Factor [dB/m]	Cable Loss [dB]	Result [dB( $\mu$ V/m)]	Limit [dB( $\mu$ V/m)]	Margin [dB]
	No Signal Detected						

NOTES:

1. \* H : Horizontal polarization , \*\* V : Vertical polarization
2. Result = Reading + Antenna factor + Cable loss
3. Margin value = Limit – Result
4. The measurement was performed for the frequency range 11.7 GHz – 12.2 GHz according to FCC Part 15.109(h).
5. No signal detected of 11.7 GHz – 12.2 GHz, Refer to plot data.
6. There are two modes (i) City Mode (ii) Highway Mode.



Test Engineer: Kug Kyoung, Yoon

## Plot data (Radiated Emissions Measurement of 11.7 GHz – 12.2 GHz)

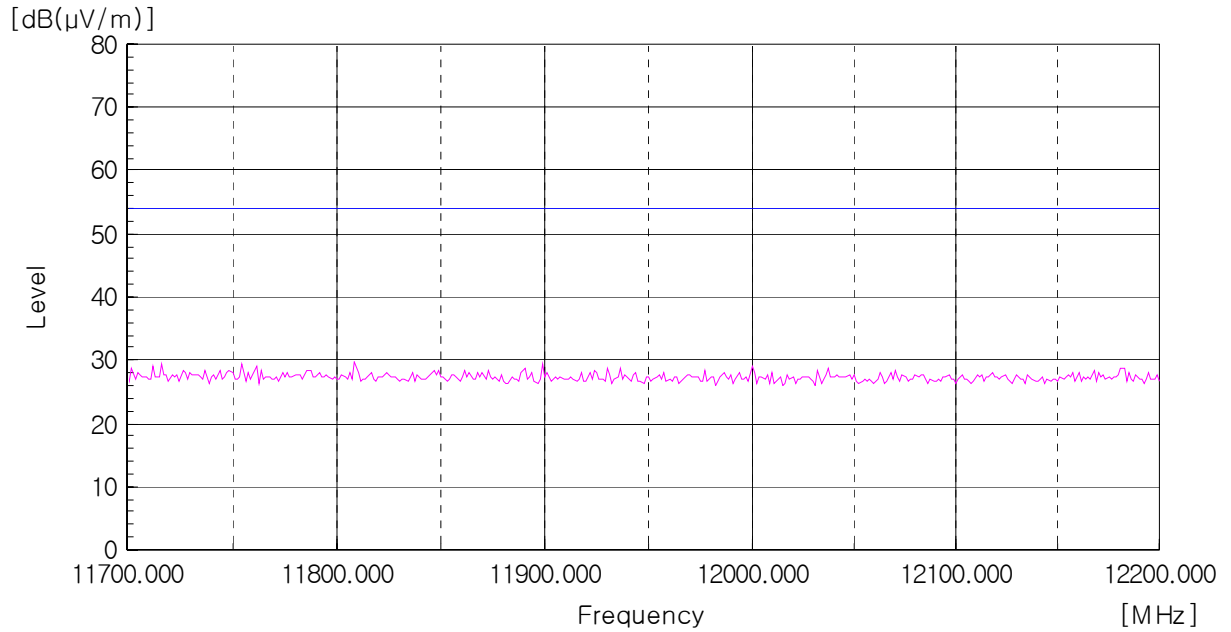

## 6. SAMPLE CALCULATION

### Sample Field Strength Calculation

The field strength is calculated by adding the Antenna Factor and Cable Factor.  
The basic equation with a sample calculation is as follows:

$$FS = RA + AF + CF$$

Where FS = Field Strength

RA = Receiver Amplitude

AF = Antenna Factor

CF = Cable Attenuation Factor

$$dB(\mu V) = 20 \log_{10} (uV) : \text{Equation}$$

## 7. List of test equipments used for measurements

	Test Equipment	Model	Mfg.	Serial No.	Cal. Due Date
<input checked="" type="checkbox"/>	Spectrum Analyzer	E7405A	H.P	US41160290	10.09.18
<input checked="" type="checkbox"/>	Horn Antenna	BBHA 9120D	Schwarzbeck	227	11.03.16
<input checked="" type="checkbox"/>	Turn-Table	MFT-120S	Max-Full Antenna Corp	-	N/A
<input checked="" type="checkbox"/>	Antenna Master	MFA-440E	Max-Full Antenna Corp	-	N/A