

1. Explanation per BLOCK

1) Summary

RADAR DETECTOR is designed to get desirable frequency by adopting SUPERHETTERODYNE method and two times of DOWN CONVERSION. In other word, it is designed to transform higher frequency then X-band to 1GHz range frequency, and then to transform it again to 10.7Mhz for easy analysis.

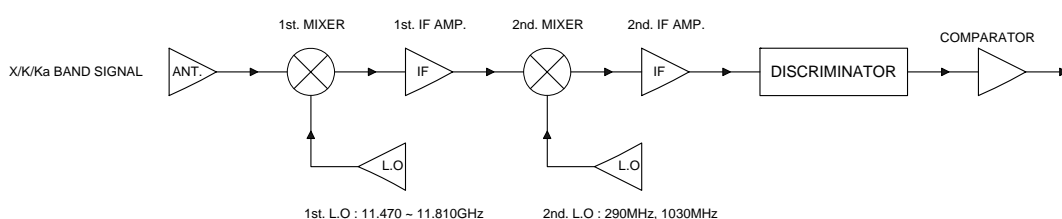

2) RF

When HORN ANTENNA receive X, K, Ka BAND frequency, 1st MIXER transforms it to 1GHz range frequency. And this signal put into the DISCRIMINATOR after two times of amplify and transformation to 10.7Mhz.

3) DISCRIMINATOR

At this stage, a desirable signal (DUAL S-CURVE) is obtained by synthesis between QUADLATURE DETECTOR inside of Discriminator and input signal. Two IFT filter is used to get maximum signal.

4) COMPARATOR

A final signal(S-DATA) is obtained when the output signal of DISCRIMINATOR pass through Comparator. ANALOG SIGNAL is converted to DIGITAL SIGNAL at this stage.

5) PROCESSOR (MCU)

MICRO-PROCESSOR define BAND ID and SIGNAL STRENGTH by S-data from Comparator, and the method is as under.

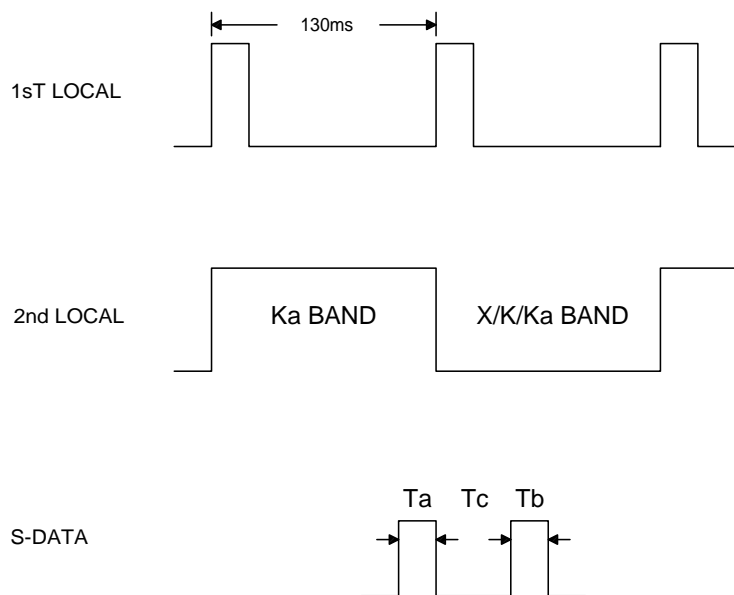

As shown in above diagram, PROCESSOR control 1st and 2nd LOCAL, and handle S-data.

S-DATA consist of Ta, Tb, Tc. The band identification is confirmed as under.

- Firstly to define “X/K/Ka BAND” or “Ka band” by checking from which position of 2nd LOCAL S-data comes (LOW SIDE : X/K/Ka BAND, HIGH SIDE : Ka BAND)
- 2ndly to define final band identification by the S-data value.

< Explanation on KEY function >

- (a) HIGHWAY MODE: To keep normal sensitivity
- (b) CITY MODE: To reduce the sensitivity to avoid false alarm in City . LED (Or ALPHA NUMERIC display is used to show on/off status of CITY mode.
- (c) MUTE MODE : To mute alarm for signal reception.
- (d) VOL+, VOL-: To adjust the alarm sound level.
- (e) POWER KEY : Power ON/OFF of RD.

6) AUDIO AMP & ALARM

When signal is received, CPU make AMP work to amplify the signal.

7) Tx &Rx (Wireless Headset) OPERATION.

<Tx : Main Unit >

The main unit function press or radar signal detector is transmit.

The Main unit appear operation band display and user listen to Tone sound .

Transmitt format included bandID and strength ID.

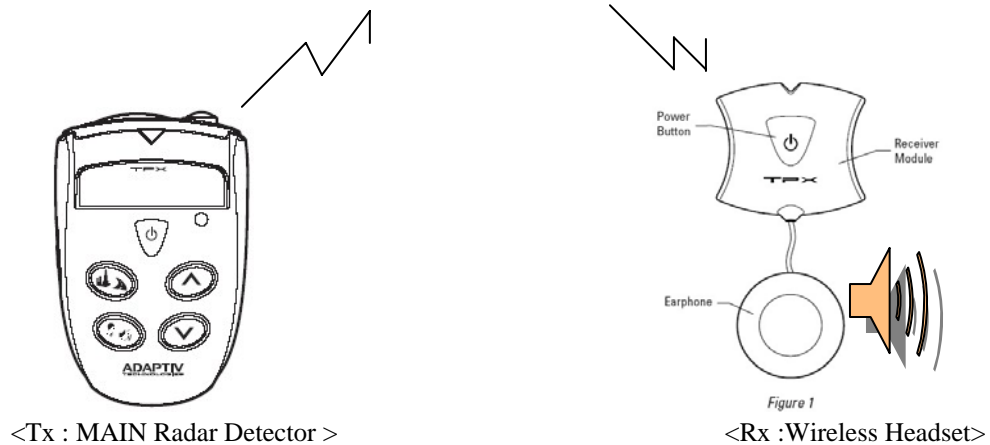

< Rx :Wireless Headset >

Power of headset can be on /off using POWER push SWITCH, and headset has battery(CR-2450).

When power is ON, LED will blink as a standby status.

And when headset receive correct signal from RD main unit, it give proper alarm to user according to band ID.

User Almost use Moterclyle.Main unit with headset Operation User is headset speaker listen to sound.

8) Manul and Auto Operation

*Main Unit function press operation.exmple mode chang and volum up&down.(Manul Tx)

* When Main Unit radar/laser signal detector is Tx formatted transmitter.(Auto Tx)

9) Show that the 418MHz transmitter and the detected radar signal stop within 5 seconds plots

