

Electromagnetic Emission
FCC MEASUREMENT REPORT
CERTIFICATION OF COMPLIANCE
FCC Part 15 Certification Measurement

PRODUCT : Radar Detector
MODEL/TYPE NO : A0101 / Proto-type
FCC ID : VVV-A0101
MULTIPLE MODEL : -
BRAND NAME : -
APPLICANT : Adaptiv Technologies, LLC
1639 11th Street, Suite 156, Santa Monica, CA 90404, U.S.A.
Attn. : Adam Gold / Director
MANUFACTURER : Willtronics Co., Ltd.
301 Kwanlidong, KwangMyung Industrial Complex, 201 Haan-3-Dong,
KwangMyung, Kyungki, Korea, 423-063
FCC CLASSIFICATION : DSC : Part 15 Security/Remote Control Transmitter
FCC RULE PART(S) : FCC Part 15 Subpart C
FCC PROCEDURE : ANSI C63.4-2003
TEST REPORT No. : ETLE110708.0605
DATES OF TEST : July 08, 2011 July 11, 2011
REPORT ISSUE DATE : July 19, 2011
TEST LABORATORY : ETL Inc. (FCC Designation Number : KR0022)

This is Radar Detector, Model A0101 has been tested in accordance with the measurement procedures specified in ANSI C63.4-2003 at the ETL Test Laboratory and has been shown to be complied with the electromagnetic radiated emission limits specified in FCC Rule Part15 Subpart C section 15.231.

I attest to the accuracy of data. All measurement herein was performed by me or was made under my supervision and is correct to the best of my knowledge and belief. I assume full responsibility for the completeness of these measurements and vouch for the qualifications of all persons taking them.

The results of testing in this report apply to the product/system which was tested only. Other similar equipment will not necessarily produce the same results due to production tolerance and measurement uncertainties.

Prepared by: 

Kug Kyoung, Yoon (Test Engineer)

July 19, 2011

Reviewed by: 

Yo Han, Park (Chief Engineer)

July 19, 2011

ETL Inc.

#371-51, Gasan-dong, Geumcheon-gu, Seoul, 153-803, Korea

Tel: 82-2-858-0786 Fax: 82-2-858-0788

The test report merely corresponds to the test sample(s).

This report shall not be reproduced, in whole or in part without the written approval of ETL Inc.

Table of Contents

FCC Measurement Report

- 1. Introduction**
- 2. Product Information**
- 3. Description of Tests**
- 4. Test Condition**
- 5. Test Results**
 - 5.1 Summary of Test Results**
 - 5.2 Radiated Emissions Measurement**
 - 5.3 Occupied Bandwidth Measurement**
 - 5.4 Periodic Operation Measurement Plot**
- 6. Sample Calculation**
- 7. List of test Equipment used for Measurement**

- Appendix A. FCC ID Label and Location**
- Appendix B. Test Setup Photographs**
- Appendix C. External Photographs**
- Appendix D. Internal Photographs**
- Appendix E. Block Diagram**
- Appendix F. Operating Description and specifications**
- Appendix G. User Manual**
- Appendix H. Circuit Diagram**
- Appendix I. Antenna Requirement**

FCC MEASUREMENT REPORT

Scope – Measurement and determination of electromagnetic emission(EME) of radio frequency devices including intentional radiators and/or unintentional radiators for compliance with the technical rules and regulations of the U.S Federal Communications Commission(FCC)

General Information

Applicant Name	: Adaptiv Technologies, LLC
Address	: 1639 11th Street, Suite 156, Santa Monica, CA 90404, U.S.A.
Attention	: Adam Gold / Director

- **EUT Type :** Radar Detector
- **Model Number :** A0101
- **FCC ID :** VWV-A0101
- **S/N :** Proto-type
- **Frequency Range :** -
- **FCC Rule Part(s) :** FCC Part 15 Subpart C section 15.231
- **Test Procedure :** ANSI C63.4-2003
- **FCC Classification :** DSC: Part 15 Security/Remote Control Transmitter
- **Dates of Tests :** July 08, 2011 July 11, 2011
- **Place of Tests :** ETL Inc. Testing Lab.

Radiated Emission test;
#499-1, Sagot-ri, Seosin-myeon, Hwaseong-si,
Gyeonggi-do, 445-882, Korea

Conducted Emission test;
ETL Inc. Testing Lab.
371-51, Gasan-dong, Geumcheon-gu, Seoul, 153-803, Korea
- **Test Report No. :** ETLE110708.0605

1. INTRODUCTION

The measurement test for radiated and conducted emission test was conducted at the ETL Inc. The site is constructed in conformance with the requirements of the ANSI C63.4-2003 and CISPR Publication 16. The ETL has site descriptions on file with the FCC for 3 m and 10 m site configurations. Detailed description of test facility was found to be in compliance with FCC Rules according to the ANSI C63.4-2003 and registered to the Federal Communications Commission (FCC Designation Number : KR0022).

The measurement procedure described in American National Standard for Method of Measurement of Radio-Noise Emission from Low-Voltage Electrical and Electronic Equipment in the Range of 9 kHz to 40 GHz (ANSI C63.4-2003) was used in determining radiated and conducted emissions from the Adaptiv Technologies, LLC Model: A0101

2. PRODUCT INFORMATION

2.1 Equipment Description

The Equipment Under Test (EUT) is the Radar Detector (model: A0101).

2.2 General Specification

General	
Dimensions	65 mm (W) x 118 mm (L) x 42 mm (H)
Weight	185 g
Power Requirement	CAR Battery 12 V DC
Temperature Range	Operating (30 ± 50) °C
	Storage (30 ± 70) °C
Laser Detector	
Receiver Type	Pulse Laser Signal Receiver
Sensor Front End	Convex Condenser Lens
Detector Type	Pulse Width Discriminator
Receiver Bandwidth	30 MHz
Spectral Response	800 nm – 1 100 nm
Radar Detector	
Receiver Type	Double Conversion Super heterodyne
Detector Type	Scanning Frequency Discriminator
Antenna Type	Linear Polarization
Frequency of Operation	10.525 GHz ± 50 MHz (X Band)
	24.150 GHz ± 100 MHz (K Band)
	34.700 GHz ± 1 300 MHz (Ka Band)
Transmitter Frequency (Tx)	
Transmitter	Manual Tx & Semi Auto
	418.00 MHz ± 75 kHz
Modulation	ASK (Amplitude shift keying)
Transmitter used in device	SAW (surface acoustic wave) RESONATOR
	NDR4047
Transmission power	Typ. -25 dBm (< -20 dBm)
Tolerance of transmission frequency	± 20 ppm
Modulation contents	Digital data
Data rate	16 bit/70 ms

3. DESCRIPTION OF TESTS

3.1 Radiated Emission Measurement

Radiated emission measurements were made in accordance with § 13 in ANSI C63.4-2003 "Measurement of Intentional radiators" The measurements were performed over the frequency range of 30 MHz to 40 GHz using antenna as the input transducer to a Spectrum analyzer or a Field Intensity Meter. The measurements were made with the detector set for "Peak, Quasi-peak, Average" within a bandwidth of 100 Hz, 9 kHz, 120 kHz and above 1 GHz is 1 MHz.

Preliminary measurements were made at 3 m using broadband antennas, and spectrum analyzer to determine the frequency producing the maximum emission in shielded room. Appropriate precaution was taken to ensure that all emission from the EUT were maximized and investigated. The system configuration, mode of operation, turntable azimuth and height with respect to the antenna were noted for each frequency found. The spectrum was scanned from 9 kHz to 30 MHz using Loop antenna and 30 MHz to 1 000 MHz using Log-Bicon antenna. Above 1 GHz, linearly polarized double ridge horn antennas were used. Final measurements were made open site at 3 m. The test equipment was laced on a wooden turn-table. Sufficient time for the EUT, support equipment, and test equipment was allowed in order for them to warm up to their normal operating condition. Each frequency found during pre-scan measurements was re-examined by manual. The detector function was set to CISPR Quasi-peak mode and the bandwidth of the receiver was set to 100 Hz, 9 kHz, 120 kHz or 1 MHz depending on the frequency of type of signal. The EUT, support equipment and interconnecting cables were re-configured to the set-up producing the maximum emission for the frequency and were placed on top of a 0.8 m high nonmetallic 1.0 m x 1.5 m table. The EUT, support equipment, and interconnecting cables were re-arranged and manipulated to maximize each emission. The turntable containing the system was rotated; the antenna height was varied 1 m to 4 m and stopped at the azimuth or height producing the maximum emission.

Varying the mode of operating frequencies of the EUT maximized each emission. The system was tested in all the three orthogonal planes and changing the polarity of the antenna. The worst-case emissions are recorded in the data tables. If necessary, the radiated emission measurement could be performed at a closer distance to ensure higher accuracy and the results were extrapolated to the specified distance using an inverse linear distance extrapolation factor (20 dB/decade) as per section 15.31(f).

Photographs of the worst-case emission can be seen in Photographs of the worst-case emission test setup can be seen in Appendix B.

3.2 FCC Part 15.205 Restricted Bands of Operations

(a) Except as shown in paragraph (d) of this section, only spurious emissions are permitted in any of the frequency bands listed below:

MHz	MHz	MHz	GHz
0.090 - 0.110	16.42 - 16.423	399.9 - 410	4.5 - 5.15
¹ 0.495 - 0.505	16.694 75 - 16.695 25	608 - 614	5.35 - 5.46
2.173 5 - 2.190 5	16.804 25 - 16.804 75	960 - 1 240	7.25 - 7.75
4.125 - 4.128	25.5 - 25.67	1 300 - 1 427	8.025 - 8.5
4.177 25 - 4.177 75	37.5 - 38.25	1 435 - 1 626.5	9.0 - 9.2
4.207 25 - 4.207 75	73 - 74.6	1 645.5 - 1 646.5	9.3 - 9.5
6.215 - 6.218	74.8 - 75.2	1 660 - 1 710	10.6 - 12.7
6.267 75 - 6.268 25	108 - 121.94	1 718.8 - 1 722.2	13.25 - 13.4
6.311 75 - 6.312 25	123 - 138	2 200 - 2 300	14.47 - 14.5
8.291 - 8.294	149.9 - 150.05	2 310 - 2 390	15.35 - 16.2
8.362 - 8.366	156.524 75 - 156.525 25	2 483.5 - 2 500	17.7 - 21.4
8.376 25 - 8.386 75	156.7 - 156.9	2 690 - 2 900	22.01 - 23.12
8.414 25 - 8.414 75	162.012 5 - 167.17	3 260 - 3 267	23.6 - 24.0
12.29 - 12.293	167.72 - 173.2	3 332 - 3 339	31.2 - 31.8
12.519 75 - 12.520 25	240 - 285	3 345.8 - 3 358	36.43 - 36.5
12.576 75 - 12.577 25	322 - 335.4	3 600 - 4 400	(²)
13.36 - 13.41			

¹ Until February 1, 1999, this restricted band shall be 0.490 MHz - 0.510 MHz.

² Above 38.6

(b) Except as provided in paragraphs (d) and (e), the field strength of emissions appearing within these frequency bands shall not exceed the limits shown in Section 15.209. At frequencies equal to or less than 1 000 MHz, compliance with the limits in Section 15.209 shall be demonstrated using measurement instrumentation employing a CISPR quasi-peak detector. Above 1 000 MHz, compliance with the emission limits in Section 15.209 shall be demonstrated based on the average value of the measured emissions. The provisions in Section 15.35 apply to these measurements.

4. TEST CONDITION

4.1 Test Configuration

The device was configured for testing in a typical fashion (as a customer would normally use it). During the tests, the EUT and the supported equipments were installed to meet FCC requirement and operated in a manner and which tends to maximize its emission level in a typical application.

4.2 EUT operation

The EUT was connected as user's guide. And during the test executed EUT is operating on the following

- Function of transmitter
The EUT (model: A0101) has been tested under operating condition.
Fixed Channel (418.00 MHz) was chosen for testing.
- Function of radar detector

Operating Mode
Stand-by mode
X Band: 10.525 GHz \pm 50 MHz
K Band: 24.150 GHz \pm 100 MHz
Ka Band (Super-wide): 34.700 GHz \pm 1 300 MHz
Laser: 800 nm ~ 1 100 nm

4.3 Support Equipment Used

Description	Model Name	Serial No.	Manufacturer
Laser Generator	NONE	NONE	NONE
Speaker	NONE	NONE	NONE
LED	NONE	NONE	NONE
DC Power Supply	DP30-05A	0300266	Toyo Tech

4.4 Type of Cables Used

Device from	Device to	Type of I/O port	Length[m]	Type of shield
EUT	Speaker	Line	1.2	Unshielded
EUT	LED	Line	1.2	Unshielded
EUT	Car battery	DC port	1.5	Unshielded
Laser Generator	DC Power Supply	DC port	1.2	Unshielded
DC Power Supply	Power socket	AC Input	1.0	Unshielded

4.5 The setup drawing(s)

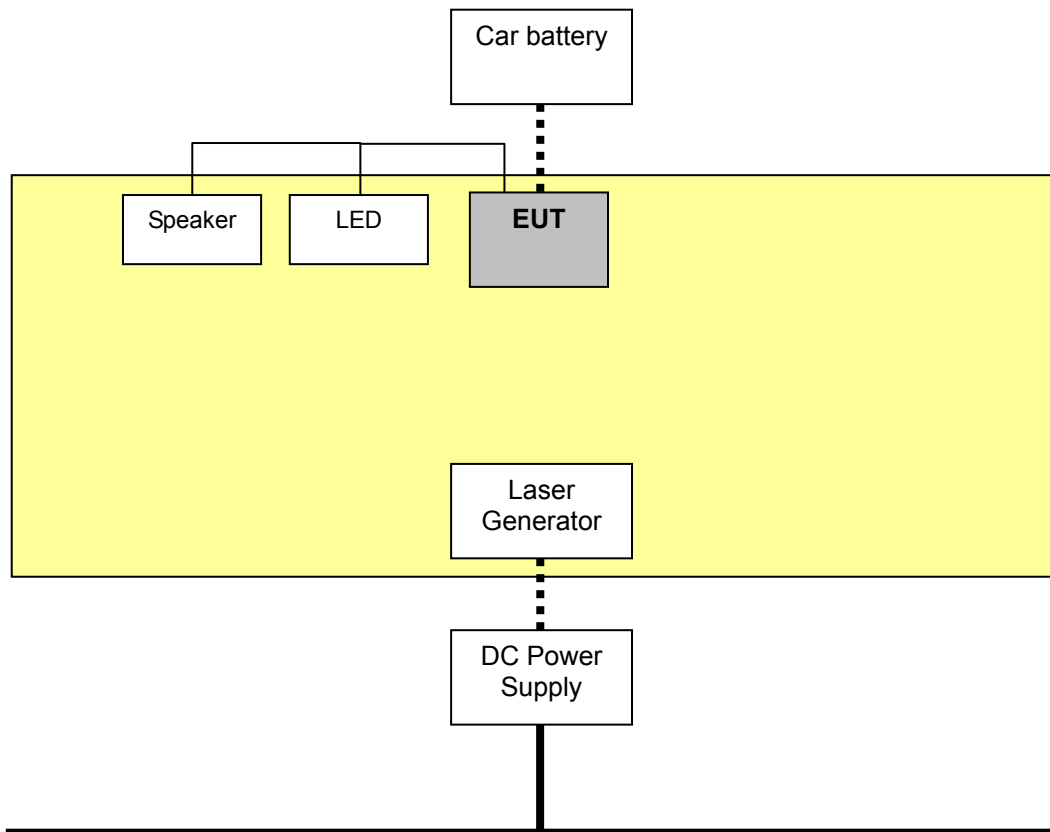

- : Data Line
- : AC Power Line
- : DC Power Line
- : Adapter

5. TEST RESULTS

5.1 Summary of Test Results

The measurement results were obtained with the EUT tested in the conditions described in this report. Detailed measurement data and plots showing the maximum emission of the EUT are reported.

Applied Standard : 47 CFR Part 15, Subpart C			
FCC Rule	Measurement Required	Result	Remarks
15.207(a)	Power line Conducted Emissions	N/A	1)
15.231(a)(1)	Manually operated transmitter	Pass	
15.231(a)(2)	Automatically activated transmitter	Pass	
15.231(a)(3)	Periodic transmissions at regular predetermined intervals	Pass	
15.231(a)(4)	Radiators used in cases of emergency	Pass	
15.231(a)(5)	Set-up information for security systems	Pass	
15.209(a) 15.231(b)	Radiated Emissions	Pass	
15.231(c)	20 dB Bandwidth	Pass	
15.231(d)	Devices operating within the frequency band 40.66 MHz - 40.70 MHz	N/A	2)
15.231(e)	Radiated emissions for Periodic radiators	N/A	2)

Notes:

- 1) The EUT is powered by DC power supply that uses Car battery only.
- 2) The frequency range of EUT is 418.00 MHz fixed.

The data collected shows that the **Adaptiv Technologies, LLC / Radar Detector / A0101** complied with technical requirements of above rules part 15.209 and 15.231 limits.

The equipment is not modified anything, mechanical or circuits to improve EMI status during a measurement. No EMI suppression device(s) was added and/or modified during testing.

5.2 Radiated Emissions Measurement

EUT	Radar Detector / A0101 (S/N: Proto-type)
Limit apply to	FCC Part 15.209(a) & 15.231(b)
Test Date	July 11, 2011
Operating Condition	Continues transmitter (418.00 MHz)
Result	Passed

Part 15.209(a) except as provided elsewhere in this Subpart, the emissions from an intentional radiator shall not exceed the field strength levels specified in the following table:

Frequencies [MHz]	Field Strength [$\mu\text{V}/\text{m}$]	Measurement Distance [m]
0.009 - 0.490	2 400/F(kHz)	300
0.490 - 1.705	24 000/F(kHz)	30
1.705 - 30.0	30	30
30 - 88	100	3
88 - 216	150	3
216 - 960	200	3
Above 960	500	3

Part 15.231(b) In addition to the provisions of Section 15.205, the field strength of emissions from intentional radiators operated under this Section shall not exceed the following:

Fundamental Frequency [MHz]	Field Strength of Fundamental [$\mu\text{V}/\text{m}$]	Field Strength of Spurious Emission [$\mu\text{V}/\text{m}$]
40.66 - 40.70	2 250	225
70 - 130	1 250	125
130 - 174	1 250 to 3 750**	125 to 375**
174 - 260	3 750	375
260 - 470	3 750 to 12 500**	375 to 1 250**
Above 470	12 500	1 250

** linear interpolations

[Where F is the frequency in MHz, the formulas for calculating the maximum permitted fundamental field strengths are as follows: for the band 130 MHz - 174 MHz, $\mu\text{V}/\text{m}$ at 3 m = $56.818 \log(F) - 6.136363$; for the band 260 MHz - 470 MHz, $\mu\text{V}/\text{m}$ at 3 m = $41.6667(F) - 7.083333$. The maximum permitted unwanted emission level is 20 dB below the maximum permitted fundamental level.]

Fundamental: $\mu\text{V}/\text{m}$ at 3 m = $41.6667(418.00) - 7.083333 = 10333.3473 = 20 \log 10333.3473$
= **80.28 dB($\mu\text{V}/\text{m}$)**
Spurious emissions: $\mu\text{V}/\text{m}$ at 3 m = 20 dB below of fundamental level
= **60.28 dB($\mu\text{V}/\text{m}$)**

Test Results

- Refer to see the measured plot in next page.

5.2.1 Radiated Emissions Data

- 9 kHz to 30 MHz

The following table shows the highest levels of radiated emissions on both polarizations of horizontal and vertical.
Detector mode: CISPR Quasi-Peak mode (100 Hz, 9 kHz)

Frequency [MHz]	Reading [dB(μV)]	Polarization (*H/**V)	Ant. Factor [dB/m]	Cable Loss [dB]	Result [dB(μV/m)]	Limit [dB(μV/m)]	Margin [dB]
Emission attenuated more than 20 dB below the limit are not reported.							

Result: All emissions below noise floor of 20 dB(μV/m)

NOTES:

1. * H : Horizontal polarization , ** V : Vertical polarization
2. Result = Reading + Antenna factor + Cable loss
3. Margin value = Limit - Result
4. The measurement was performed for the frequency range 9 kHz to 30 MHz according to FCC Part 15.209.

- 30 MHz to 4.2 GHz

The following table shows the highest levels of radiated emissions on both polarizations of horizontal and vertical.
 Detector mode: Quasi-Peak mode (RBW: 120 kHz) below 1 GHz
 Peak or AV mode (RBW: 1 MHz) above 1 GHz

Frequency [MHz]	Reading [dB(μV)]	Polarization (*H/**V)	Ant. Factor [dB/m]	Cable Loss [dB]	Result [dB(μV/m)]	Limit [dB(μV/m)]	Margin [dB]
333.58	15.03	H	13.70	4.77	33.50	46.00	12.50
Below 1 GHz: Emission attenuated more than 20 dB below the limit are not reported.							
Above 1 GHz: No signal detected emissions							

**Result: Below 1 GHz: Emission attenuated more than 20 dB below the limit are not reported.
 Above 1 GHz: No signal detected emissions**

NOTES:

- * H : Horizontal polarization , ** V : Vertical polarization
- Result = Reading + Antenna factor + Cable loss
- Margin value = Limit - Result
- Results found to be 20 dB or greater under the limit have not been included.
- The measurement was performed for the frequency range 30 MHz - 4.2 GHz according to the FCC Part 15.209(a)

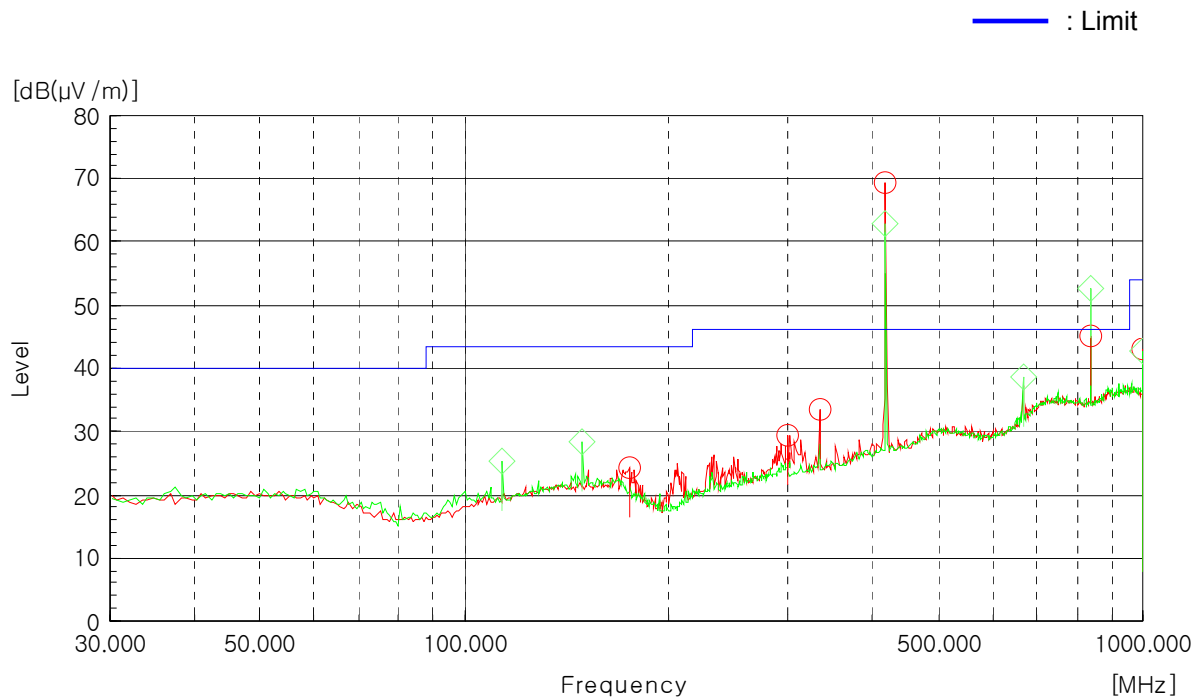

— : Limit

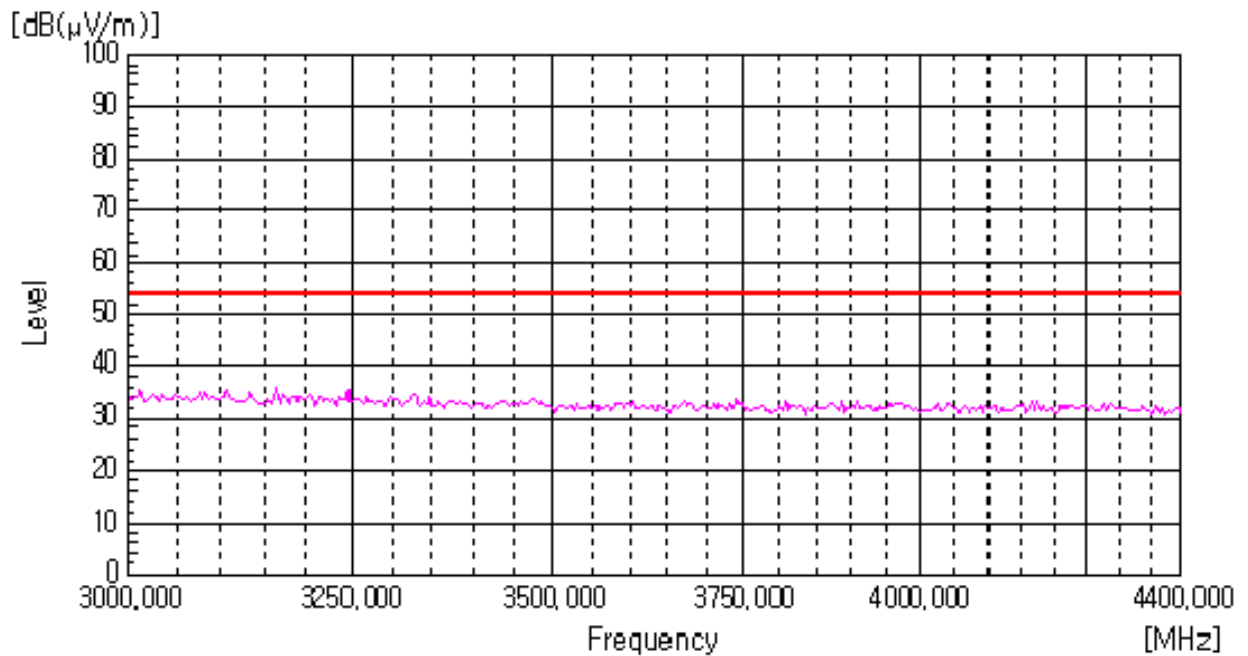
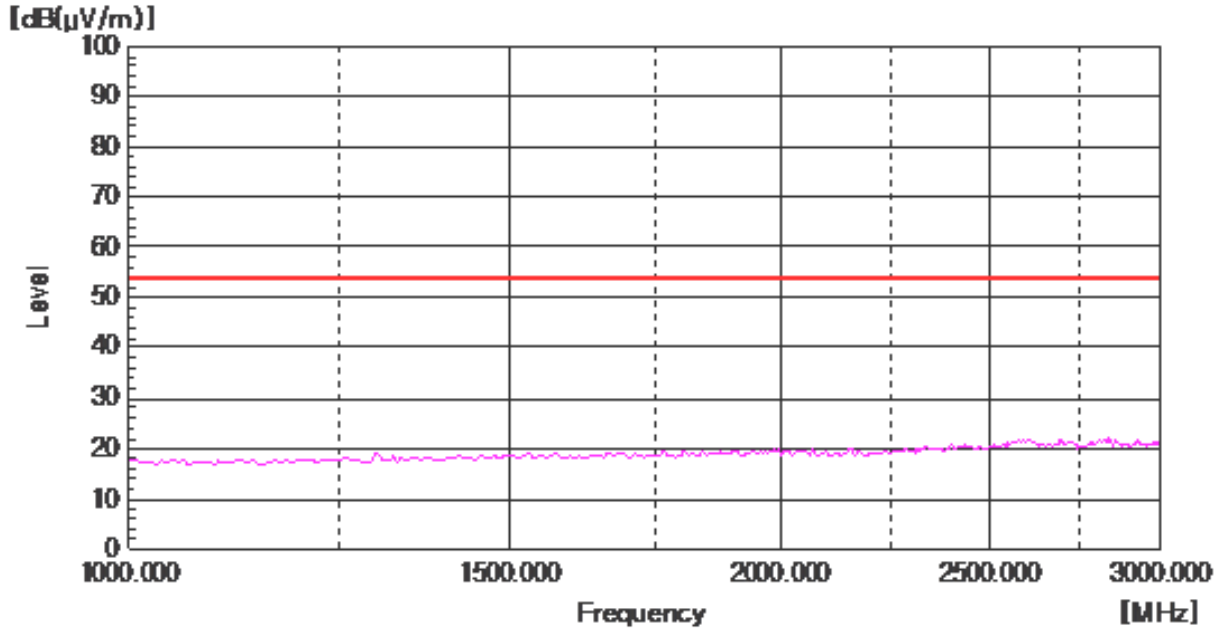

5.2.2 Field Strength of Fundamental

- Peak mode test data

Frequency [MHz]	Reading [dB(μV)]	Polarization (*H/**V)	Ant. Factor [dB/m]	Cable Loss [dB]	Result [dB(μV/m)]	Limit [dB(μV/m)]	Margin [dB]
418.00	48.40	V	15.68	5.42	69.50	100.28	30.78

- Average mode test data

Frequency [MHz]	Reading [dB(μV)]	Polarization (*H/**V)	Ant. Factor [dB/m]	Cable Loss [dB]	Duty Cycle Factor [dB]	Result [dB(μV/m)]	Limit [dB(μV/m)]	Margin [dB]
418.00	48.40	V	15.68	5.42	-21.33	48.17	80.28	32.11

5.2.3 Spurious Emissions Data

- Peak mode test data

Frequency [MHz]	Reading [dB(μV)]	Polarization (*H/**V)	Ant. Factor [dB/m]	Cable Loss [dB]	Result [dB(μV/m)]	Limit [dB(μV/m)]	Margin [dB]
837.32	22.29	V	21.99	8.42	52.70	80.28	27.58
Other frequencies	-	-	-	-	-	-	-

- Average mode test data

Frequency [MHz]	Reading [dB(μV)]	Polarization (*H/**V)	Ant. Factor [dB/m]	Cable Loss [dB]	Duty Cycle Factor [dB]	Result [dB(μV/m)]	Limit [dB(μV/m)]	Margin [dB]
837.32	22.29	V	21.99	8.42	-21.33	31.37	60.28	28.91
Other frequencies	-	-	-	-	-	-	-	-

Result: No signal detect emissions above 1 GHz

NOTES:

1. The test was searched from 30 MHz to the 10th Harmonic. (30 MHz - 4.2 GHz)
2. Average level = Peak level + Duty factor.

— Peak Limit Line
— AV Limit Line

Final data Peak

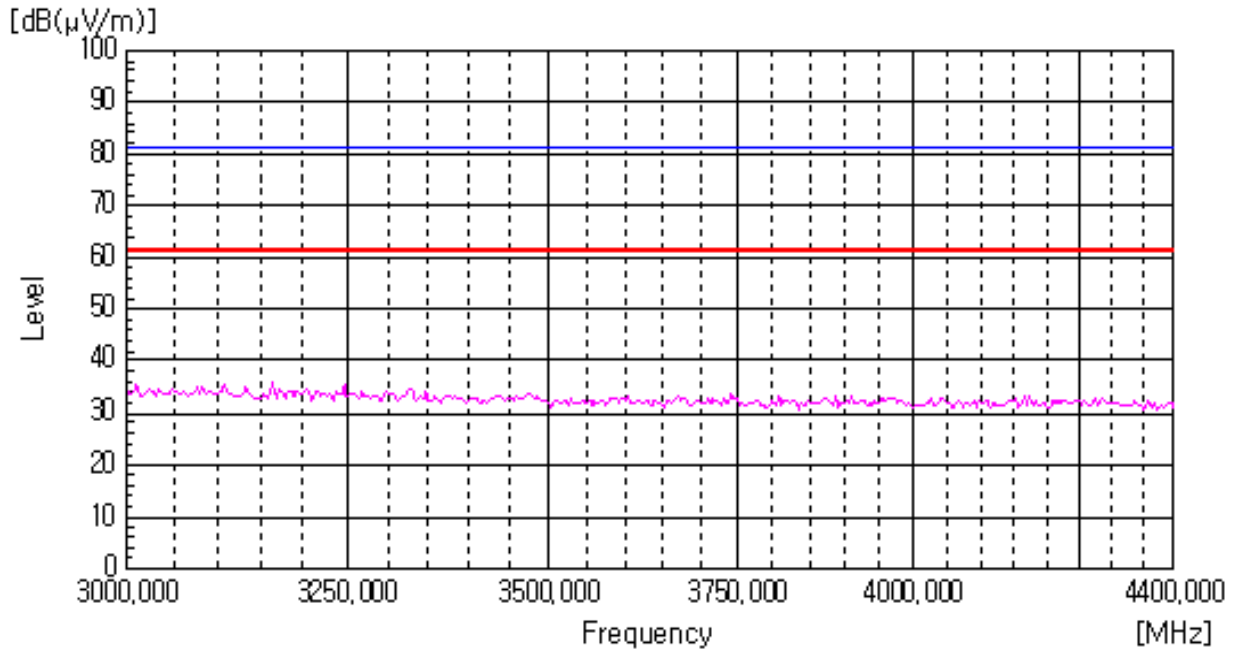
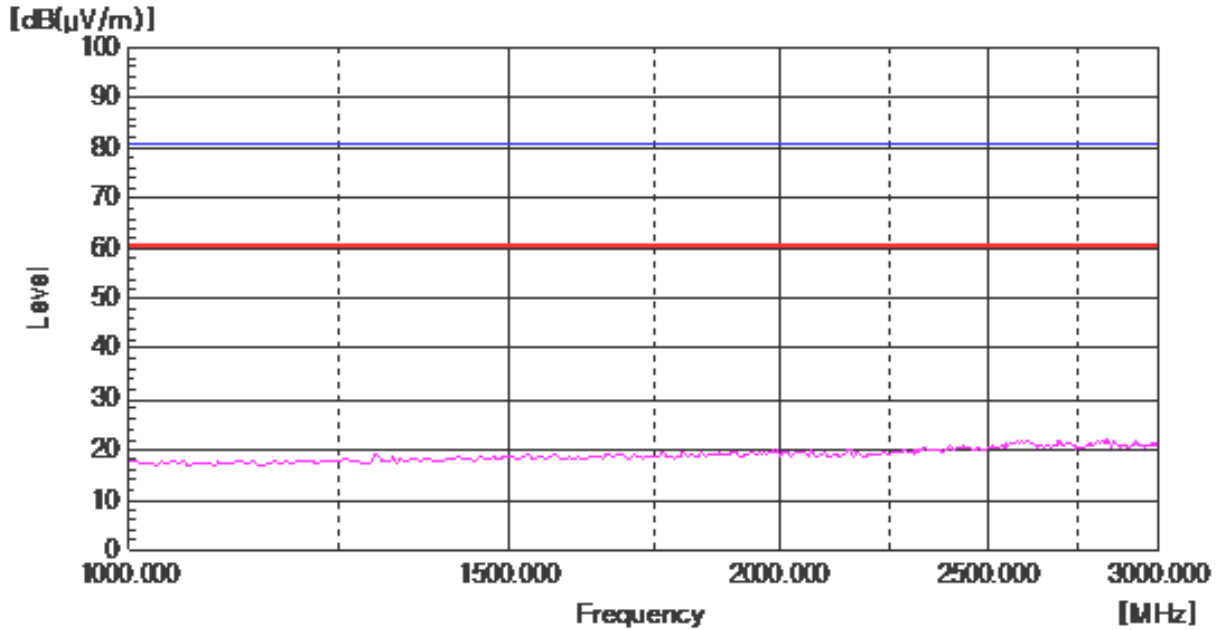

— Peak Limit Line
— AV Limit Line

Final data AV

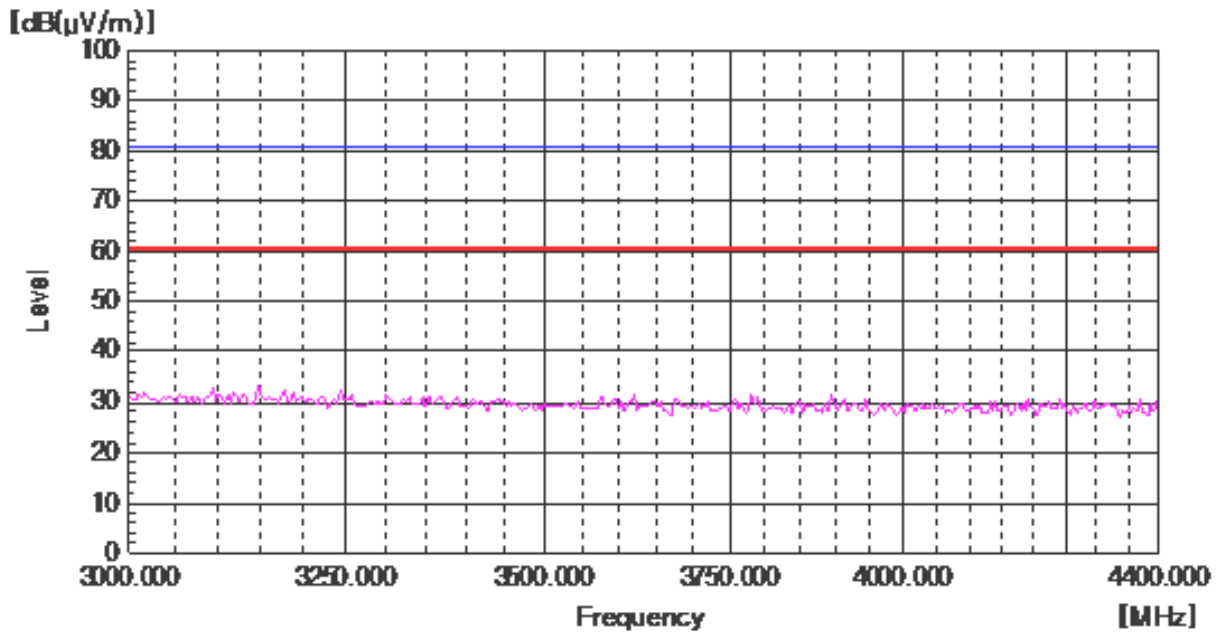
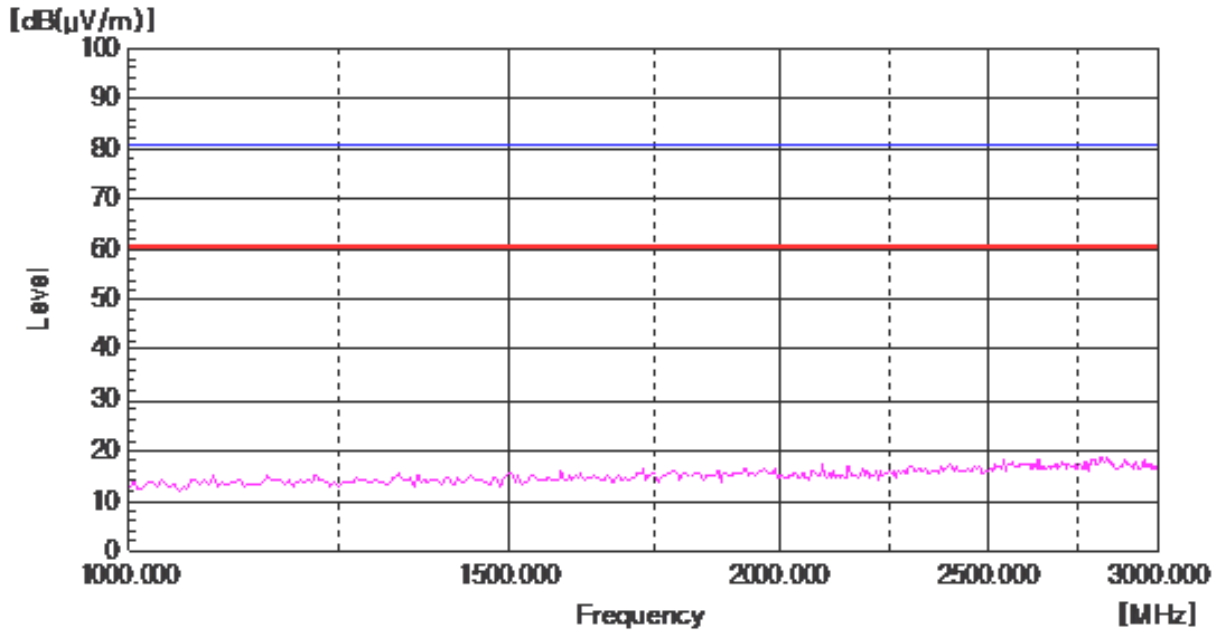

5.3 Occupied Bandwidth Measurement

5.3.1 20 dB Bandwidth

EUT	Radar Detector / A0101 (S/N: Proto-type)
Limit apply to	FCC Part 15.231(c)
Test Date	July 08, 2011
Operating Condition	Continues transmitter (418.00 MHz)
Result	Passed

Limit

The bandwidth of the emission shall be no wider than 0.25 % of the center frequency for devices operating above 70 MHz and below 900 MHz. For devices operating above 900 MHz, the emission shall be no wider than 0.5 % of the center frequency. Bandwidth is determined at the points 20 dB down from the modulated carrier.

Test Data

Center Frequency [MHz]	Measured occupied bandwidth [MHz]	Limit [MHz]	Result
418.00	0.470	1.045 (0.25 %)	Pass

NOTES:

1. Please see the measured bandwidth plot in next page.
2. The bandwidth is determined at the points 20 dB down from the modulated carrier.

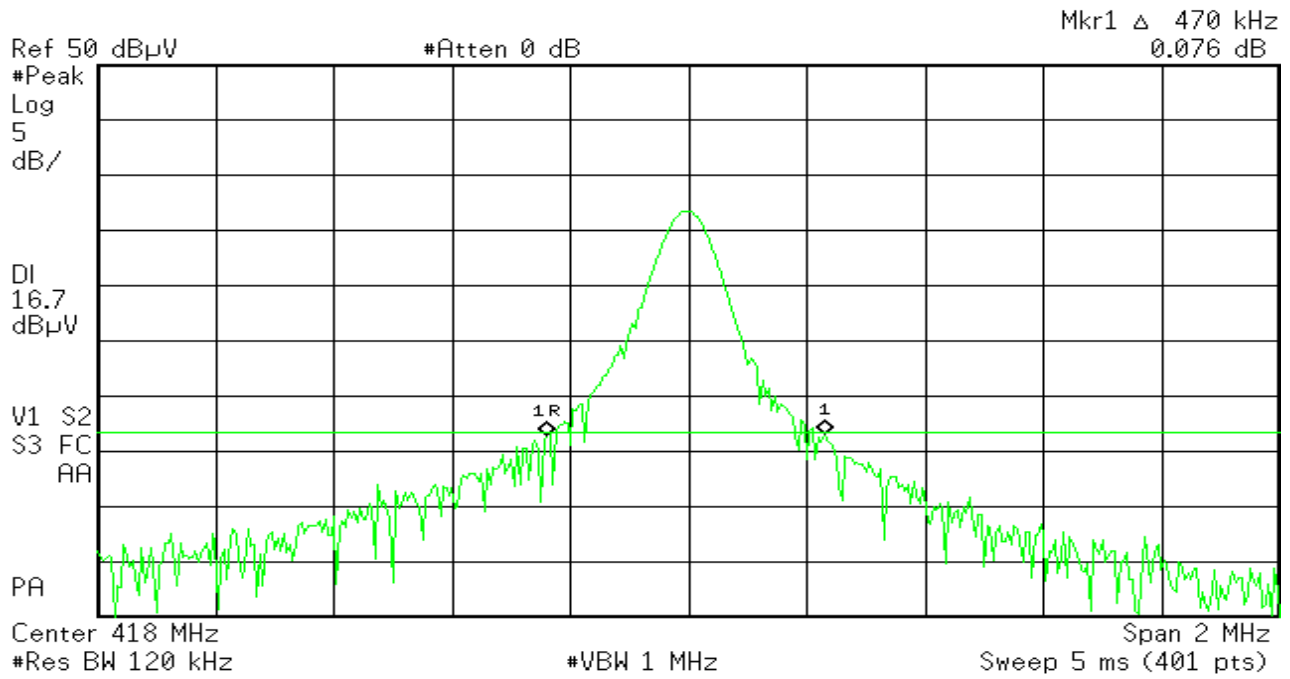

5.4 Periodic Operation Measurement Plot

TX on time = 11.71 ms

Limit [s] = 5 s

Result ■ Pass □ Fail

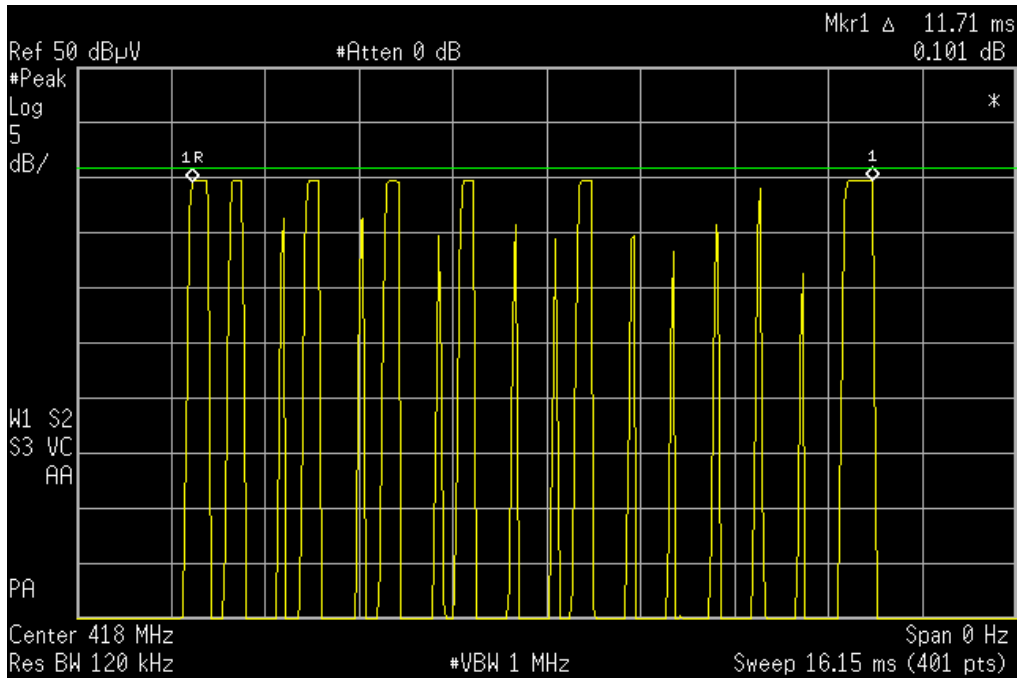

5.4.1 Duty cycle

Calculation;

Duty cycle factor = $20 \log(\text{on time}/\text{period})$

$$20 \log(3.23 \text{ ms}/100.0 \text{ ms}) = -29.82 \text{ dB}$$

On time = $0.19 \text{ ms} * 17 = 3.23 \text{ ms}$

Period = 100.0 ms

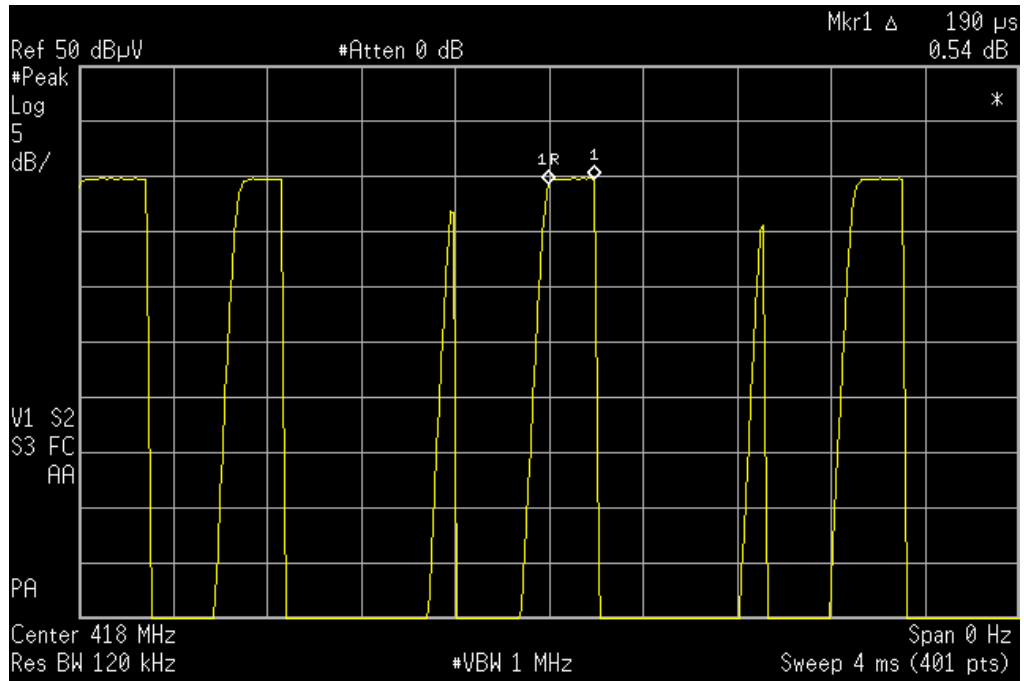

6. SAMPLE CALCULATION

Sample Field Strength Calculation

The field strength is calculated by adding the Antenna Factor and Cable Factor.
The basic equation with a sample calculation is as follows:

$$FS = RA + AF + CF$$

Where FS = Field Strength

RA = Receiver Amplitude

AF = Antenna Factor

CF = Cable Attenuation Factor

$$\text{dB}(\mu\text{V}) = 20 \log_{10} (\mu\text{V})$$

$$\text{dB}(\mu\text{V}) = \text{dBm} + 107$$

Example : @ 333.58 MHz

Limit	=	46.00 dB($\mu\text{V}/\text{m}$)
Reading	=	15.03 dB(μV)
Antenna Factor + Cable Loss	=	13.70 + 4.77 = 18.47 dB($\mu\text{V}/\text{m}$)
Total	=	33.50 dB($\mu\text{V}/\text{m}$)
Margin	=	46.00 – 33.50 = 12.50 dB
	=	12.50 dB below Limit

7. List of test equipments used for measurements

	Test Equipment	Model	Mfg.	Serial No.	Cal. Date	Cal. Due Date
<input checked="" type="checkbox"/>	EMI Test Receiver	ESVS 10	R&S	835165/001	11.03.22	12.03.22
<input checked="" type="checkbox"/>	Spectrum Analyzer	E7405A	H.P.	US41160290	10.09.17	11.09.17
<input checked="" type="checkbox"/>	Horn Antenna	BBHA 9120D	Schwarzbeck	227	11.03.22	13.03.22
<input checked="" type="checkbox"/>	LogBicon Antenna	VULB9160	Schwarzbeck	3082	10.02.22	12.02.22
<input checked="" type="checkbox"/>	Loop Antenna	AL-130	Com-Power	17100	11.02.10	13.02.10
<input checked="" type="checkbox"/>	Amplifier	AFS42-01001800-28-10P-42	MITEQ Inc.	1565819	11.02.14	12.02.14
<input checked="" type="checkbox"/>	System Power Supply	6030A	Agilent	1036546	11.03.22	12.03.22
<input checked="" type="checkbox"/>	Controller	HD2000	HD GmbH	C/125	N/A	N/A
<input checked="" type="checkbox"/>	Antenna Master	MA2400	HD GmbH	N/A	N/A	N/A
<input checked="" type="checkbox"/>	Turn-Table	MFT-120S	Max-Full Antenna Corp	-	N/A	N/A
<input checked="" type="checkbox"/>	Antenna Master	MFA-440E	Max-Full Antenna Corp	-	N/A	N/A