

Explanation of symbols

On the packaging, on the type plate of the meter and on the lancing device, you may encounter the symbols shown below. They have the following meanings:



Consult the instructions for use



Caution (refer to accompanying documents)! Please refer to safety related notes in the instructions for use accompanying this instrument.



Store at



Use by / Expiry date



For single use only



Sterilized using irradiation



Manufacturer



Catalogue number



Lot number



For in vitro diagnostic use



0088 Blood glucose meter: This product fulfils the requirements of Directives 98/79/EC on in vitro diagnostic medical devices and 1999/5/EC on radio and telecommunications terminal equipment (R&TTE).

Lancing device and lancet drum: These products fulfil the requirements of Directive 93/42/EEC on medical devices.



This device complies with Part 15 of the FCC Rules and with RSS-210 of Industry Canada.



This device complies with the Japanese Radio Law 100.

The explanation of any other symbols can be found in the instructions for use/inserts accompanying components within the packaging.

Last update: 2008-08

Intended use

Accu-Chek Mobile blood glucose meter

Meter for quantitative determination of blood glucose values in fresh capillary blood using Accu-Chek Mobile test cassettes.

Suitable for self-testing only.



The meter may only be used for blood glucose testing by one person.

There is a risk of infections being transmitted if the meter is used by other people, or if health-care professionals use the same meter for testing blood glucose in more than one person. This meter is therefore not suitable for professional use in healthcare facilities or institutions.



Parenteral administration of Galactose, Maltose (e.g. present in some human immunoglobulin preparations) and Icodextrin (a maltose polysaccharide) may cause overestimation of blood glucose results. Blood concentrations of Galactose >7 mg/dl (>0.39 mmol/l) or Maltose >20 mg/dl (>0.58 mmol/l) will cause overestimation of blood glucose results.

Accu-Chek FastClix Mobile lancing device

Lancing device with adjustable penetration depth setting for obtaining capillary blood from a fingertip with Accu-Chek FastClix lancet drums and, when a special AST cap is used, also from alternate sites such as the ball of the thumb.



The lancing device is intended for personal use only!

It may only be used by one person for obtaining blood. There is a risk of infections being transmitted if the lancing device is used by other people, or if healthcare professionals use this lancing device to obtain blood from more than one person. This lancing device is therefore not suitable for professional use in healthcare facilities or institutions.

About this User's Manual

Please read this User's Manual carefully and completely before testing blood glucose for the first time. If you have any questions, please contact your customer support and service centre (see Chapter 21).

This User's Manual helps you get to know your meter and lancing device step by step. It provides you with all the information you need to operate and care for your meter and lancing device and to deal with any errors that might occur. Remember that, in order to keep your meter and lancing device in good working condition, you need to follow the correct operating procedures and also observe certain other instructions. The meter and lancing device are precision instruments and improper handling can impair their operation.

This User's Manual features three symbols to draw your attention to important information. Please read these notes with special care.



This symbol indicates a possible risk of injury or of damage to your own health or to the health of others.



This symbol draws attention to actions that could result in **damage to the meter, the test cassette or the lancing device**.



This symbol draws your attention to important information.

All instructions describing specific operations are printed on a colored background as shown in the following **example**:



- 1 Place your finger on the corrugated area on the tip cover and push it in the direction of the arrow as far as it will go.

Please note:

All dates, times or results displayed in this User's Manual are intended only as examples. They display results in mmol/l (e.g. 5.8 mmol/l), dates in the month day format (e.g. Feb 26) and times in the 12-hour clock (e.g. 06:30pm). Others can (and will) be displayed on your meter's display. Your meter can, for example, display the time or date in a different format (depending on the setting you have chosen).



We recommend that you start by getting to know all of the features of your meter and lancing device (see Chapter 1.1 and 1.2). Try out all the steps described in this User's Manual, and also practise using the meter and lancing device.

Contents

1	Getting to know your meter and lancing device	13
1.1	Components of the meter.....	14
1.2	Components of the lancing device.....	17
1.3	The blood glucose test in brief	18
1.4	The main features at a glance.....	20
1.5	Description of menu and buttons.....	23
	Elements of the menus.....	24
	 button (On/Off button / Enter button)	26
	 button (down).....	28
	Taste  (Auf).....	29
1.6	Turning on the meter.....	30
1.7	Turning off the meter	32
	Using the On/Off button	32
	Via the Main menu	33
1.8	Opening menus.....	34
1.9	Entering information.....	37
	Changing numbers	37
	Activating or deactivating functions	38
2	Initial steps before testing	39
2.1	Checking the contents	39
2.2	Checking the blood glucose unit.....	40

2.3	Inserting the first test cassette	41
	Validity of the test cassette	46
2.4	Removing the protective film from the display	48
2.5	Removing the protective strip from the batteries	48
2.6	Setting the language	49
3	Testing blood glucose	54
3.1	Preparing the lancing device	55
	Inserting a lancet drum.....	57
	Setting the penetration depth	59
	Loading a new lancet	60
	Replacing a used lancet drum	61
	Undocking and docking the lancing device	62
3.2	Performing a blood glucose test	64
	Starting a blood glucose test by opening the tip cover	65
	Starting a blood glucose test via the Main menu	68
	Obtaining a blood drop	70
	Applying the blood drop to the test area.....	73
	Turning off the meter	75
	Symbols which are displayed together with the result.....	77
	Flagging results.....	78

3.3	Evaluating results.....	84
	Measuring range	84
	Implausible results – possible sources of error	85
4	Making settings	86
4.1	Settings overview.....	86
4.2	Opening the Settings menu	89
4.3	Setting the time and date, selecting the time format	91
	Setting the time.....	92
	Setting the date.....	95
	Selecting the time format	98
4.4	Setting tones.....	100
	Turning the beeper, reminders and acoustic mode on and off.....	102
4.5	Setting reminders	104
	Setting a new reminder	106
	Editing an existing reminder (turn on/off, change, delete).....	109
	Setting a single reminder in 1 hour, 2 hours or 3 hours	115
	Deleting a single reminder.....	117
4.6	Zielbereich einstellen	119
	Setting a target range.....	120
	Editing an existing target range (turn on/off, change)	122

4.7	Setting the volume	126
4.8	Setting the brightness	128
4.9	Setting the language	130
	Correcting a wrongly set language.....	132
5	Using the meter as an electronic notebook	133
5.1	Viewing saved results	134
	Via the <i>Memory</i> menu.....	135
	Via the  button (down).....	137
5.2	Viewing averages.....	139
5.3	Transferring results	144
	Starting the transfer using the  and  buttons.....	147
	Starting the transfer via the <i>Memory</i> menu.....	148
	Transferring data for further analysis	149
	Transferring results as table	151
	If the transfer is unsuccessful.....	155
5.4	Setting the display format for viewing saved results.....	156
6	Acoustic mode	159
6.1	Beep tone when turning on	161
6.2	Beep tones during a test	161

6.3	Announcement of the result after a test.....	162
	mmol/l meters.....	163
6.4	Announcements of warnings and error messages	164
7	Checking the meter	165
7.1	Preparing for a control test.....	166
7.2	Performing a control test.....	167
	Control test not OK – possible sources of error	176
8	Tools menu	178
9	Performing a display check	179
10	Viewing the validity of the test cassette	181
11	Cleaning the meter and lancing device	182
11.1	Cleaning the meter.....	182
	The outside	182
	The inside	183
11.2	Cleaning the lancing device.....	192
12	Replacing the test cassette	193
12.1	Preparing cassette replacement.....	194
12.2	Replacing the cassette	195

13 Viewing the number of available tests	201
14 Changing the batteries	202
15 Testing and storage conditions	207
15.1 Temperature	207
15.2 Humidity	208
15.3 Light conditions	209
15.4 Local sources of interference	209
16 Symbols, messages, problems and error messages	211
16.1 Symbols.....	211
16.2 Messages	212
16.3 Problems	218
16.4 Error messages.....	220
17 Disposing of the meter	226
18 Technical data	228
19 System components	231

20 Patents	232
21 Customer support and service centre	233
21.1 Advice and troubleshooting	233
21.2 Addresses	233
22 Alphabetical index	234
23 Menu overview	240

1 Getting to know your meter and lancing device

This chapter introduces you to

- the meter
- the lancing device
- the blood glucose test
- the main features of the meter and lancing device

It then describes

- what the menus look like
- how the meter is turned on and off
- how menus are opened
- how information is entered.

You can only perform a blood glucose test or make settings in the meter if you have performed the initial steps before testing (see Chapter 2).

1.1 Components of the meter

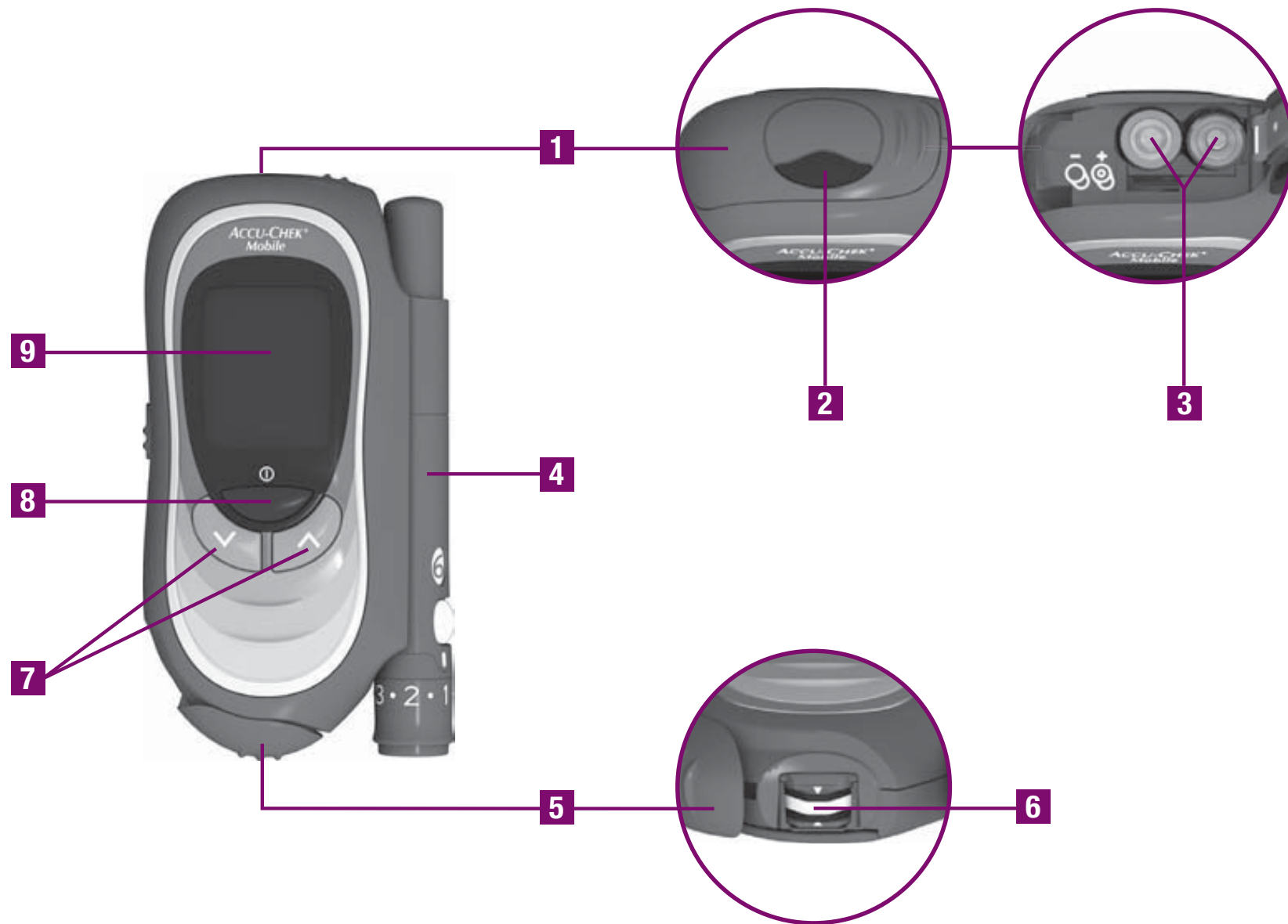

- 1** Battery compartment cover (right: from above; far right: open)
- 2** Infrared window (integrated interface for transferring data to a computer, for example)
- 3** Batteries [1.5 V, type AAA, alkaline-manganese or high energy batteries (2 batteries required)]
- 4** Lancing device (docked)
- 5** Tip cover (bottom right: open)
- 6** Test area (at the tip of the cassette ready for a test)
– this is where you apply the blood
- 7** Down/Up buttons
- 8** On/Off and Enter button
- 9** Display

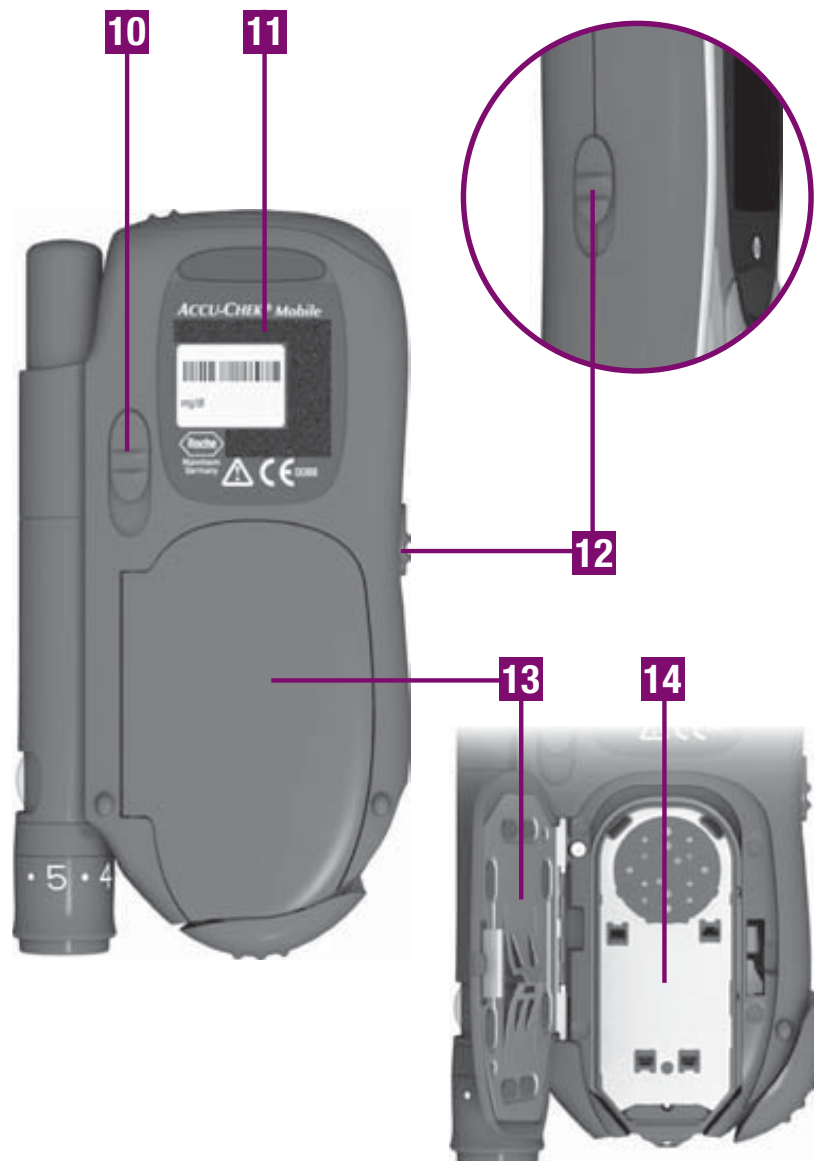

- 10** Release button for undocking the lancing device
- 11** Type plate
- 12** Release button for opening the cassette compartment cover
- 13** Cassette compartment cover (bottom: open)
- 14** Test cassette (in place in the meter)

1.2 Components of the lancing device

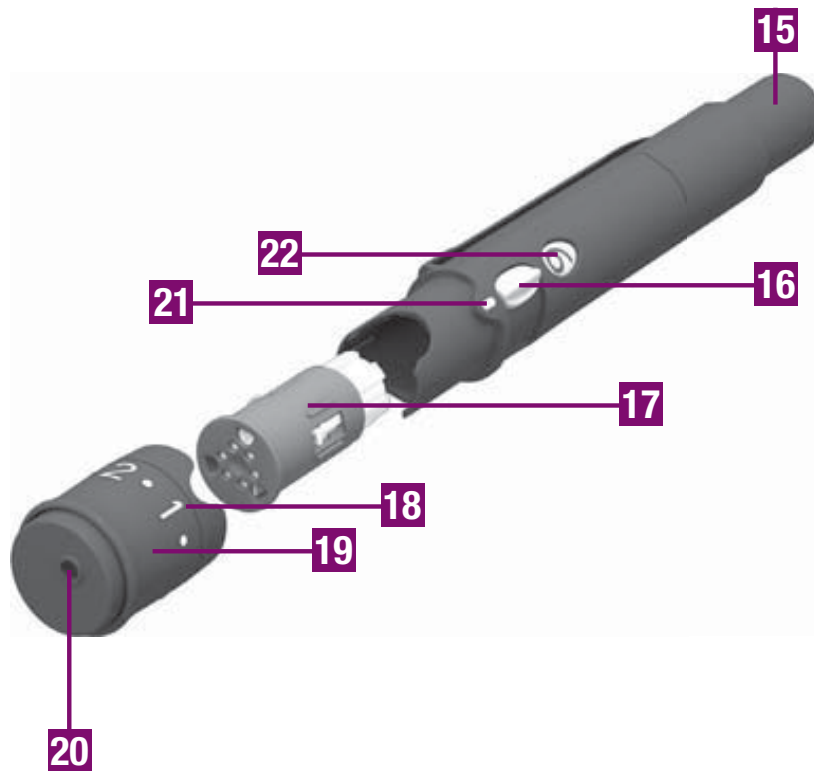

- 15** Multifunction button (priming and lancing)
- 16** Lever for rotating the lancet drum and loading a new lancet
- 17** Lancet drum containing 6 lancets
- 18** Numbers indicating penetration depth settings
- 19** Rotatable cap (rotating the cap on the device sets the penetration depth)
- 20** Pin-hole opening for lancet
- 21** Penetration depth indicator
- 22** Window showing number of available lancets

1.3 The blood glucose test in brief



1 Open tip cover



2 Prime lancing device



3 Obtain blood



4 Apply blood



5 Read result



6 Close tip cover

1.4 The main features at a glance

■ Test cassette instead of test strips

The test cassette contains a continuous tape on which there are 50 test areas. When a test is to be performed a test area is automatically advanced to the tip of the cassette.

■ Easy testing

For testing, you do not need to press a single button. You open the tip cover, apply blood to the test area, read the result and close the tip cover.

■ Docked lancing device

You can obtain blood with the lancing device still docked onto the meter. Or you can undock the lancing device and then use it to obtain blood.

■ Lancing device with lancet supply

A drum containing 6 sterile lancets is placed in the lancing device. Pushing the lever on the lancing device rotates the drum to the next lancet. This means that you can obtain blood with a new and sterile lancet 6 times before you have to replace the drum.

■ No coding

Each test cassette contains an RFID (radiofrequency identification) chip. This automatically codes the meter when you insert a test cassette and informs the meter about the specific properties of the test areas in this test cassette.

■ **Blood volume checking**

The meter checks whether you have applied sufficient blood (approx. $0.3 \mu\text{L} = 0.3$ thousandths of a millilitre) before starting to test.

■ **Luminous display**

All information on the display appears yellow on a black background. You can adjust the brightness to suit the ambient conditions and make it easier to read.

■ **Text-supported operation**

The meter takes you through all the operations step by step in the language you have selected. There are 15 languages to choose from. Some of the text is supported by symbols and graphics.

■ **Menu-driven operation**

The settings and functions of the meter are sorted by topic into different menus. You will find an overview of the menus at the end of the User's Manual.

■ **Reminders**

You can set reminder times, e.g. to remind you to perform a test. At the set time a beep will sound and the reminder time will be displayed.

■ **Target range for results**

You can enter your personal target range for blood glucose values. The target range gives the blood glucose values which should be achieved if the treatment is optimal. If a result is above or below this range, a symbol on the display will draw your attention to this.

- **Flagging results**

You can flag results with various symbols which indicate particular situations during the test.

- **Memory**

The meter automatically saves up to 500 results with the time and date of the test and all other information that is important for the test.

- **Integrated data analysis**

From the stored results, your meter can calculate your averages for the last 7, 14 or 30 days.

- **Data transfer**

The meter has an infrared window. This enables you to transfer stored results to a computer.

1.5 Description of menu and buttons

This chapter tells you how the menus are arranged, what the different symbols in them mean and how to use the buttons to navigate through the menus. You will find a complete overview of the menus at the end of the User's Manual.

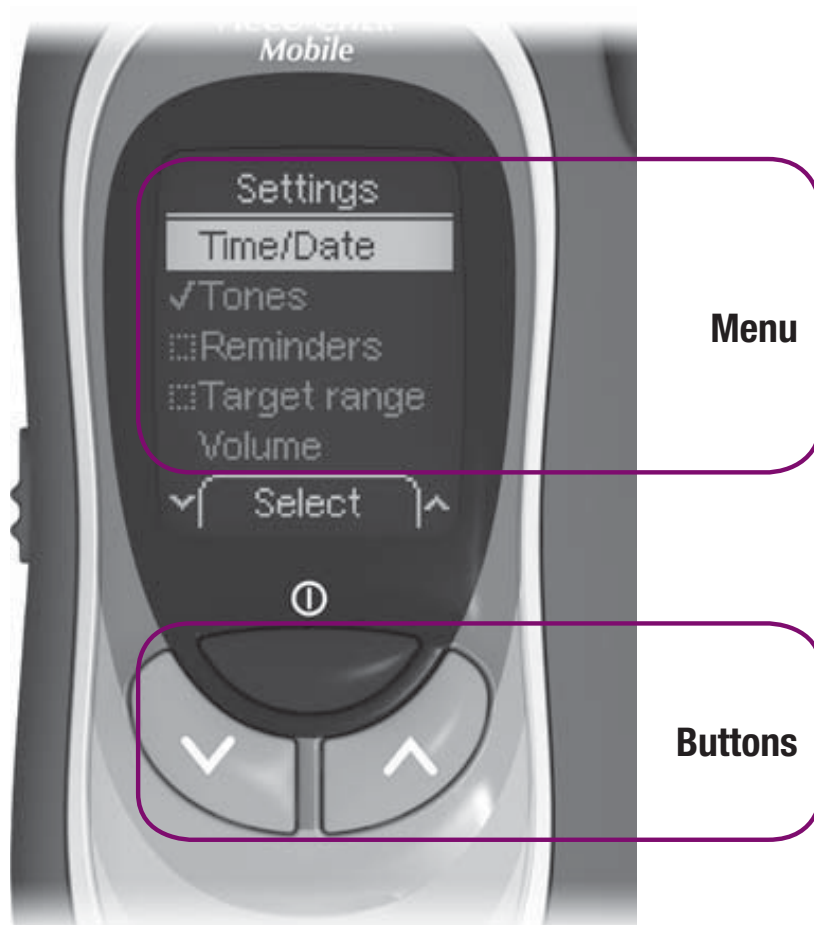

Menu

When the meter is on, the selected menu is displayed in the language you have set.

Buttons

The three buttons below the display allow you to navigate through the menu.

Elements of the menus

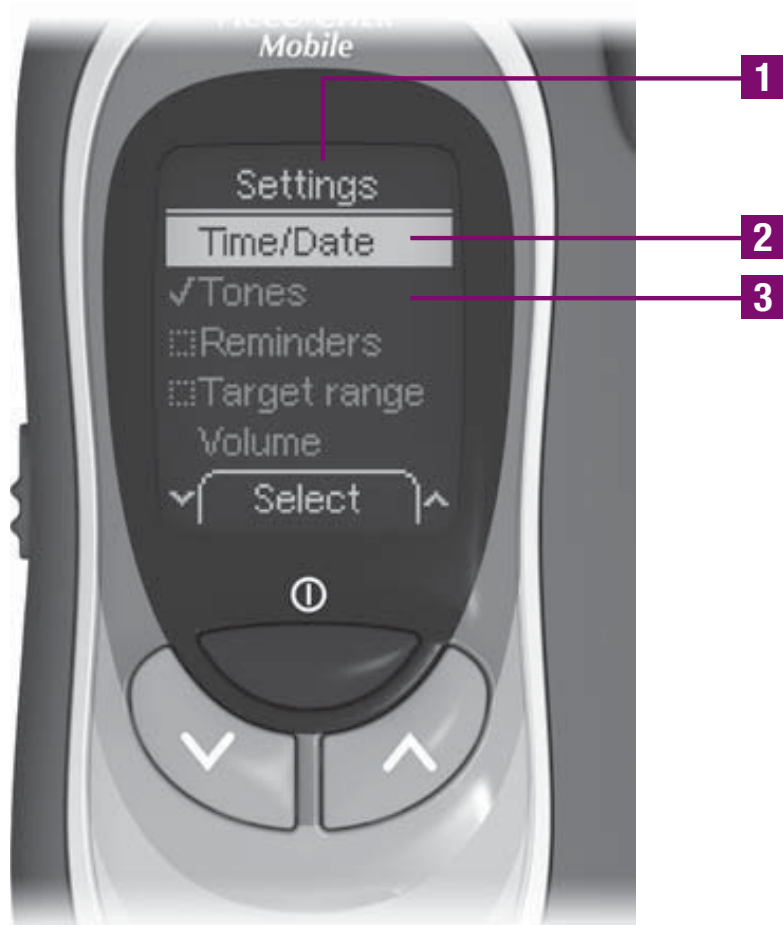

The following illustrations show the main elements that can appear in a menu.

- 1** Title of the display or menu (not in all displays)
- 2** Selected item, highlighted with a yellow bar. If you press the  button, this item will be selected (command "Select" above the button). This will take you to a higher- or lower-level menu, for example, or open the display for entering a number.
- 3** Unselected item.

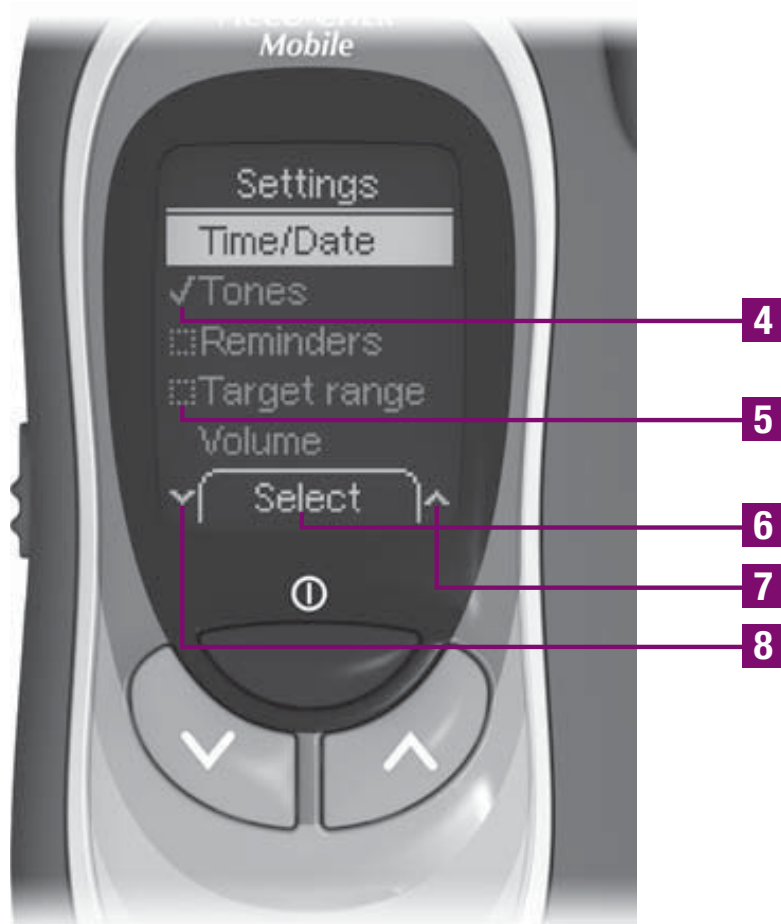

4 The symbol  indicates that the function (here *Tones*) is activated.

5 The symbol  indicates that the function (here *Target range*) is deactivated.

6 The command displayed here will be executed if you press the  button. The particular command displayed depends on the current display (see description of the On/Off and Enter button).

7 The symbol  means that there are further items above the first item visible on the display.

8 The symbol  means that there are further items below the last item visible on the display.

 button (On/Off button / Enter button)



 This button allows you

- to turn the meter on or off (**press and hold** the button, see Chapter 1.6 and 1.7); as On/Off button, this button is indicated in the User's Manual by the symbol ,

or

- to execute the command displayed above the button (**press and release** the button); as Enter button to execute the command displayed, the button is indicated by the symbol .

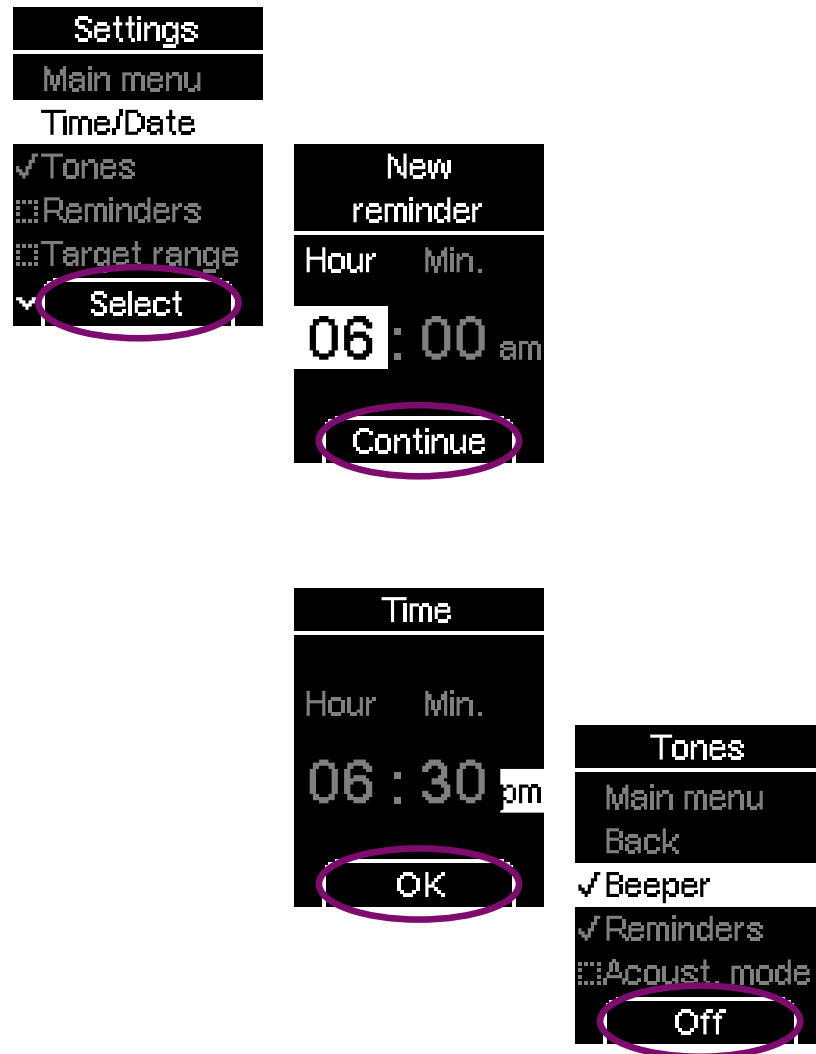

There are various commands, for example (see illustrations on left):



- *Select* selects the highlighted item. This will take you to a higher- or lower-level menu, for example, or open the display for entering a number.
- *Continue* takes you from hours to minutes.
- *OK* confirms the displayed time.
- *Off* turns the beeper off.

Getting to know your meter and lancing device

button (down)



-  This button allows you to
- navigate down in a menu or list
- or
- make numbers smaller.

The  button (down) is indicated by the symbol  in the User's Manual.



Taste  (Auf)



-  This button allows you to
- navigate up in a menu or list
- or
- make numbers bigger.

The  button (up) is indicated by the symbol  in the User's Manual.

1.6 Turning on the meter

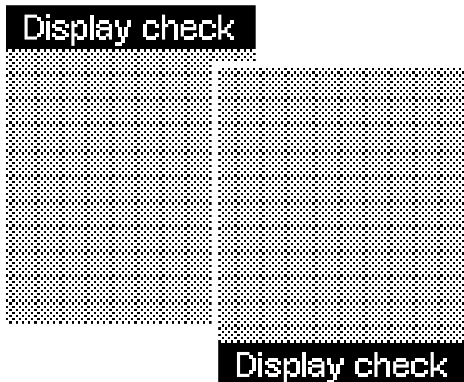

- 1 With the meter off, press and hold the On/Off  the meter turns on (longer than 2 seconds).

In the remainder of the User's Manual, this instruction will appear in the following abbreviated form:

- 1 Turn on the meter using .

The meter first runs a display check in which a black and yellow checkerboard pattern of small illuminated dots is displayed.

- 2 Check that there are no irregularities in the checkerboard pattern.

Some examples of irregularities in the checkerboard pattern are shown in Chapter 9.

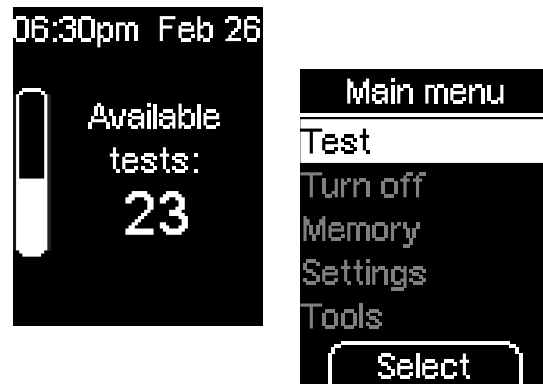

The meter automatically exits the display check after about 2 seconds.

After the display check, the meter first displays the number of tests still available on the test cassette and then opens the main menu.

1.7 Turning off the meter



Press and hold
button
to switch off
meter



Press and hold
button
to switch off
meter



Available
tests:
22



There are 2 different ways of turning off the meter:
using the On/Off  button or via the Main menu.

Using the On/Off button

Press and hold the On/Off  button until the bar on the display is filled (at least 2 seconds).

In the remainder of the User's Manual, this instruction will appear in the following abbreviated form:



Turn off the meter with  aus.

After this, the number of available tests is displayed and the meter turns off.

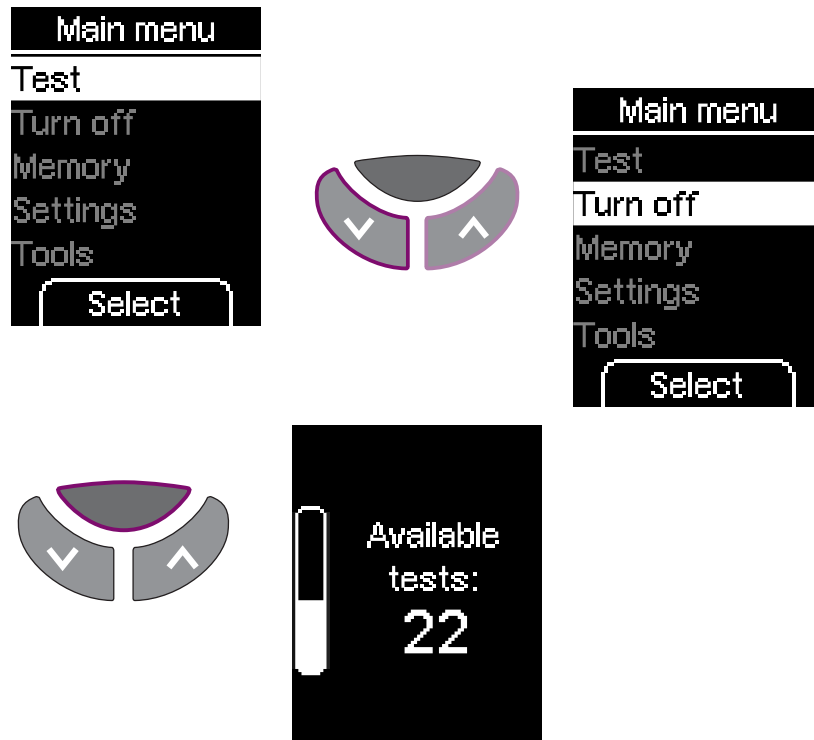
You can turn the meter off at any time using the On/Off button. If you release the On/Off button before the bar is full, the meter returns to the previous display.



Via the Main menu

- 1 Open the Main menu.
- 2 Use the  or  button to go to the item *Turn off*.

- 3 Press the  button (*Select*).

The meter displays the number of available tests and then turns off.

In the remainder of the User's Manual, this way of turning off the meter will appear in the following abbreviated form:

- 1 Turn off the meter via *Turn off*.

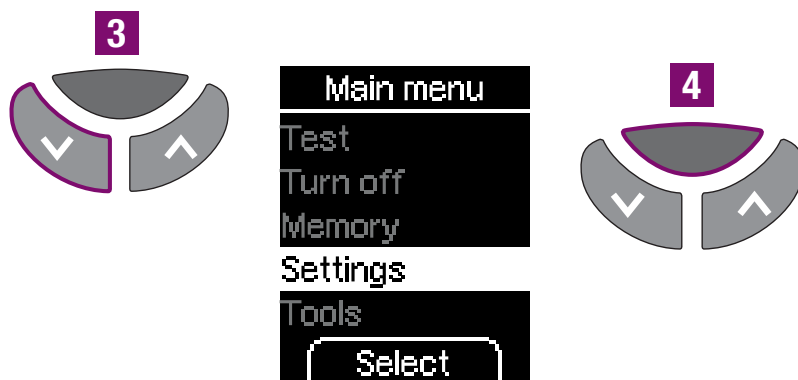
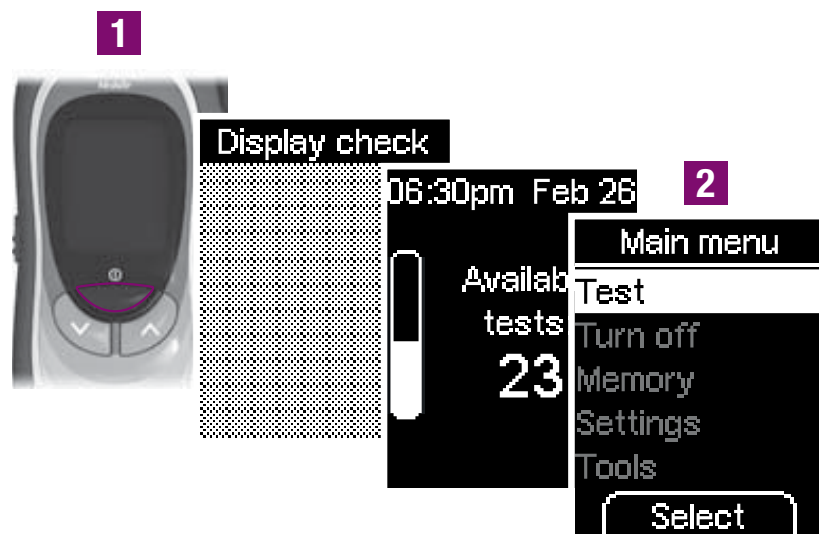

1.8 Opening menus



The procedure for opening a menu is always the same.

Example: Opening the *Date* menu

- 1 Turn on the meter with .
- 2 Wait until the Main menu is displayed.

- 3 Press the  button three times until the item *Settings* is highlighted by the yellow bar.
- 4 Press the  button (*Select*) to open the Settings menu.

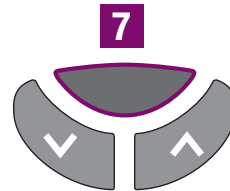
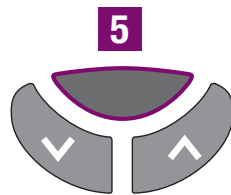

The *Time/Date* menu is highlighted.

5 Press the  button (*Select*) to open the *Time/Date* menu.







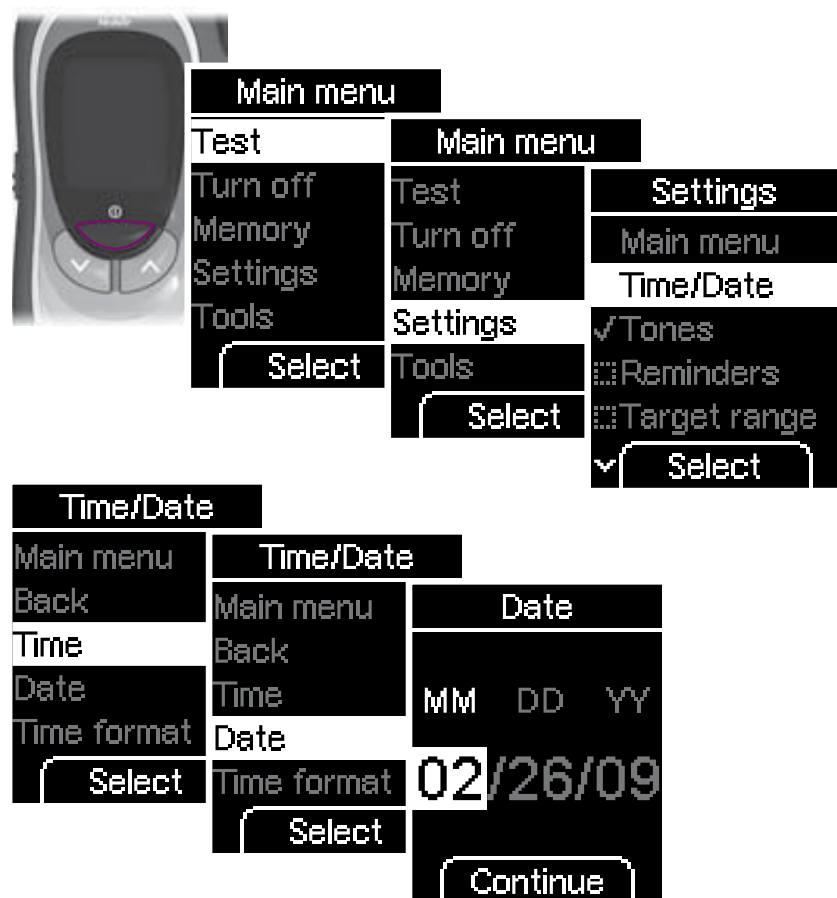



6 Use the  or  button to select the item *Date*.

7 Press the  button (*Select*) to set the date.

The *Date* menu is now open.



In the User's Manual, the steps for opening the *Date* menu are summarized as follows:

- 1 Turn on the meter with ,
 - use   to select *Settings*,
 - press  to open *Settings*,
 - use   to select *Time/Date*,
 - press  to open *Time/Date*,
 - use   to select *Date*,
 - press  to open *Date*.

The procedure for opening other menus is described in the same way.

1.9 Entering information



Changing numbers

Numbers highlighted by a yellow background can be changed.

Press the  button to make a number smaller.

If you press the button once, the number decreases by 1. If you hold the button down, the number continues to decrease until you release the button.

Press the  button to make a number bigger.

If you press the button once, the number increases by 1. If you hold the button down, the number continues to increase until you release the button.

Activating or deactivating functions

Some functions, e.g. the beeper and flagging results can only be activated or deactivated.

You can recognize these functions by the fact that there is either a tick ✓ or a checkbox ☐ in front of them and the command above the  button is *Off* or *On* (if there is a different command this means that the function can also be modified).

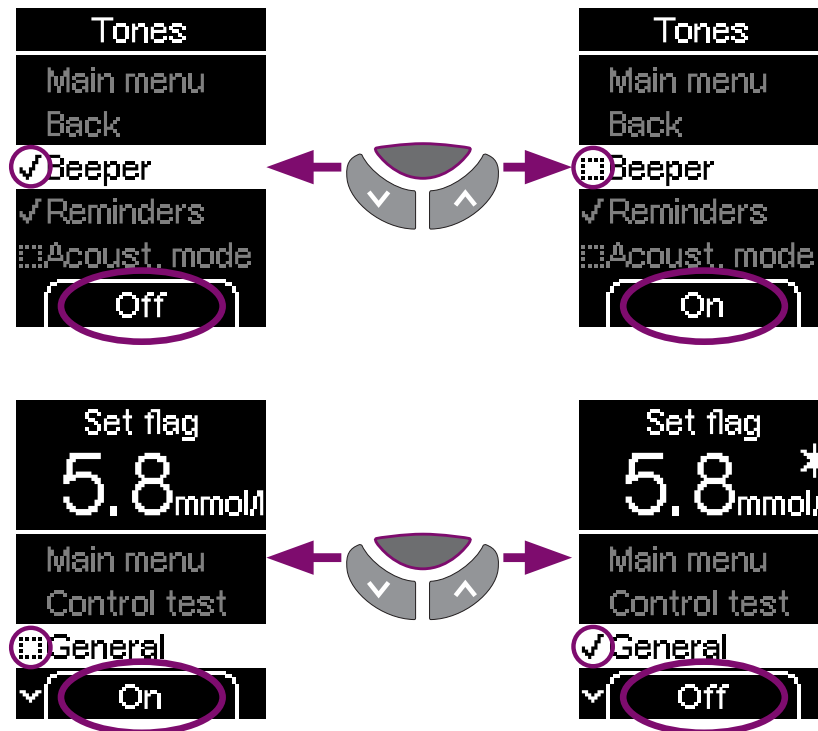

A tick ✓ means that the function is activated. The command for the  button is *Off* to allow you to deactivate the function.

Press the  button (*Off*) to deactivate the activated function.

A checkbox ☐ means that the function is deactivated. The command for the  button is *On* to allow you to activate the function.

Press the  button (*On*) to activate a deactivated function.

2 Initial steps before testing

2.1 Checking the contents

Check that the contents of the package are complete.

The package contents are listed on the box. If anything is missing, please contact your customer support and service centre. You will find the address at the end of this User's Manual.

2.2 Checking the blood glucose unit

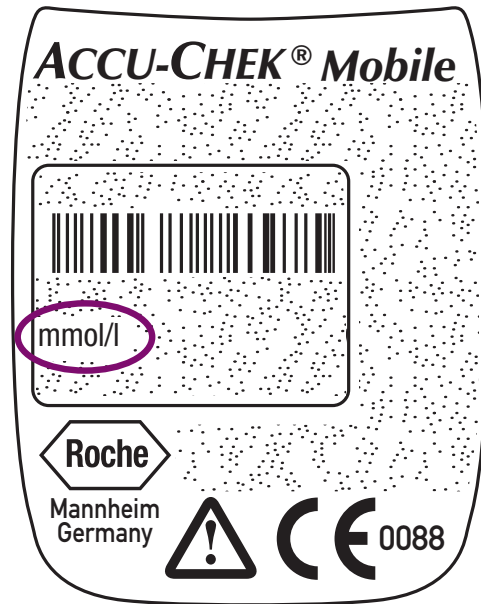

Blood glucose results can be displayed in two different units of measurement (mmol/l and mg/dl). Consequently, two different versions of the same meter are sold. Check that your meter displays the unit of measurement you are accustomed to. You can find the unit of measurement that your meter displays on the type plate on the back of your meter. If you do not know which is the right unit of measurement for you, ask your doctor.

 The unit of measurement that your meter displays cannot be changed. If the wrong unit is printed on the type plate, ask your dealer to change the meter or contact your customer support and service centre. Using the wrong unit of measurement can cause you to misinterpret the results.

2.3 Inserting the first test cassette

If your meter is brand new and unused, it does not contain a test cassette.



Please read the test cassette package insert. It contains important information on storage and possible causes of incorrect results, for example.



If the packaging is damaged, you must not use the test cassette. Otherwise, there is a risk that you might obtain incorrect results. Incorrect results can cause the wrong therapeutic decision to be taken and so produce serious adverse health effects.



Only remove the test cassette from its packaging when you want to insert it into the meter. The packaging protects the test cassette against damage and moisture.



Insert the very first test cassette in the meter before you remove the protective strip from the batteries and start using the meter.



A table is printed on the test cassette box which shows the permitted results for control tests (checking the meter with glucose control solution). The meter automatically checks whether the result of a control test is correct. If you wish to check the result yourself as well, you can do this with this table. Keep the test cassette box in case you need it for this purpose. Please note that the table is only valid for the test cassette that comes in the same box. Test cassettes from other boxes have other tables.

Initial steps before testing



- 1 Place your finger on the corrugated area on the tip cover and push it in the direction of the arrow as far as it will go. You must feel the tip cover click into place.



- 2 Turn the meter over.



- 3 Push the release button for the cassette compartment cover in the direction of the arrow. The cover springs open.



- 4 Open the cassette compartment cover all the way. You have to overcome a resistance, accompanied by an audible CLICK, just before it is fully opened.



The cassette compartment cover is fully opened when it is at an angle of slightly more than ninety degrees – as shown in the illustration.



5 Remove the cassette from the packaging.

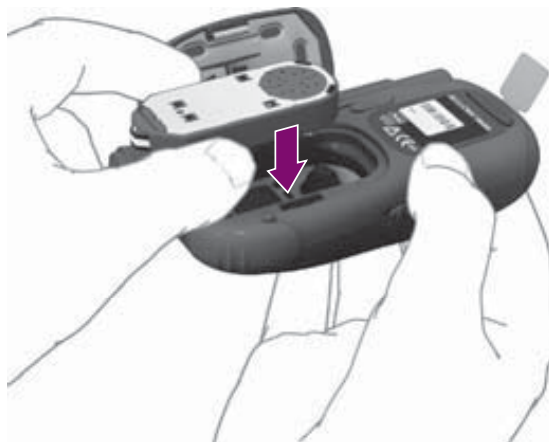

6 Insert the cassette in the meter with the silver side facing upwards.

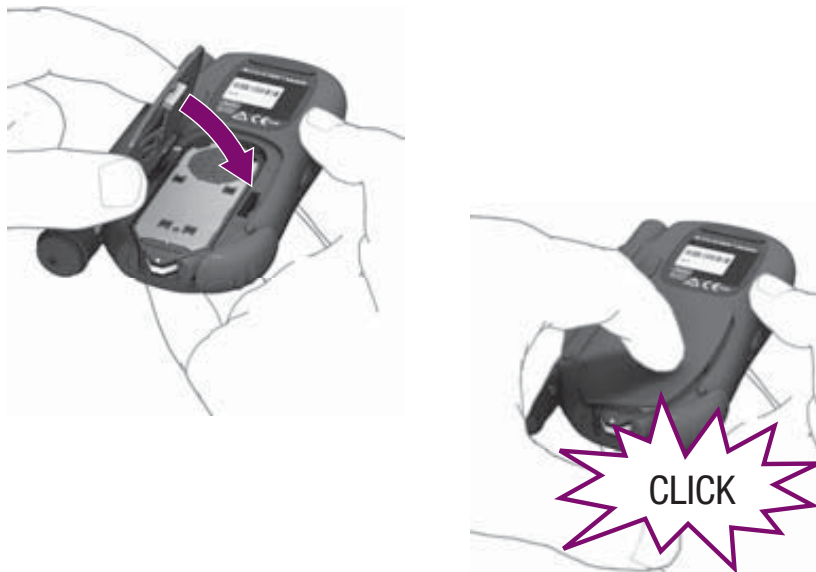

7 Close the cassette compartment cover and press it closed. You must hear an audible **CLICK**.



8 Push the tip cover in the direction of the arrow as far as it will go. You must feel the tip cover click into place.

Validity of the test cassette

When a test cassette is in the meter, the meter checks regularly when the cassette was inserted and calculates the use-by period from this. Each test cassette must be used up within 3 months (use-by period). If you insert a started test cassette into the meter, the use-by period is calculated from the date when the cassette was placed in the meter for the first time. This date is stored in the cassette.

The meter also checks whether the expiry date of the cassette has been reached. The expiry date is shown on the test cassette box next to the symbol .

If either of the two dates – use-by period or expiry date – is exceeded, the validity of the cassette has expired. You cannot perform any more tests with this test cassette.

If you start a test and the validity of the cassette is about to expire shortly or has already expired, the meter will inform you of this.



The first notification appears 10 days before the validity of the cassette expires, the following appear 5, 2 and 1 day(s) before expiry.

Press the  button (*Continue*) to start a test.



If the validity of the test cassette has expired, the message on the left appears.

Turn off the meter with  and insert a new test cassette.

2.4 Removing the protective film from the display

The meter's display is protected by a protective film.

Peel this protective film off.



2.5 Removing the protective strip from the batteries

The meter is supplied with batteries inserted. The battery contacts are covered with a protective strip to prevent premature loss of battery power. This protective strip must be removed before you can start using the meter.

Pull the protective strip backwards out of the meter.



i Instructions for changing the batteries are given in Chapter 14.

2.6 Setting the language

When you have inserted a test cassette and removed the protective film from the display and the protective strip from the batteries (see Chapter 2.3 to 2.5), you must set the language in which text will be displayed on the meter. The meter automatically prompts you to do this the first time you turn it on.

There are a total of 15 languages to choose from.

- English US
- English UK
- Deutsch
- Español
- Italiano
- Français
- Dansk
- Svenska
- ニホンゴ
- Türkçe
- Português
- Ελληνικά
- Norsk
- Suomi
- Nederlands







- 1 With the meter off, press and hold the On/Off  button until the meter turns on (longer than 2 seconds).

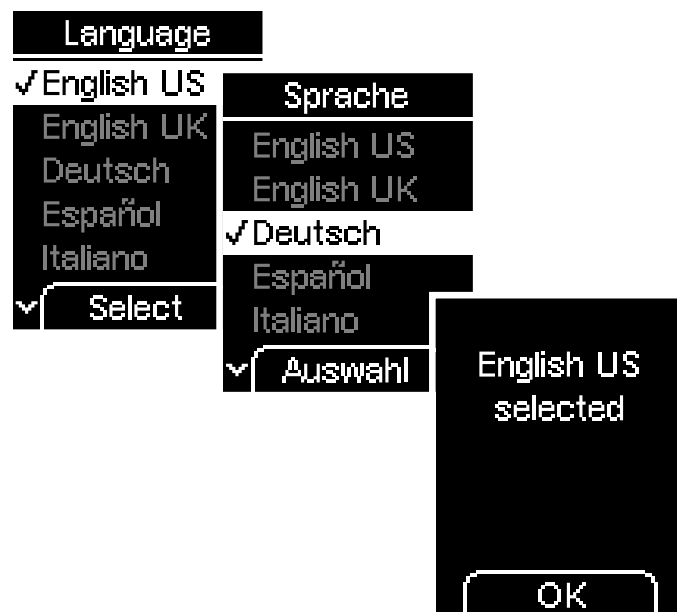

When you turn on the meter for the first time, the language selection menu is automatically displayed.

The default language is *English US*. You can either select this language or replace it by a different one.



- 2 Press the  or  button repeatedly until the desired language is highlighted.
- 3 Then press the  button below the display to select the highlighted language.

The meter will then display the language you just selected.

- 4 Confirm this information by pressing the  button (*OK*).

 If you selected the wrong language by mistake you can change this setting later (see Chapter 4.9). However, until you do so, the menu will be displayed in the language you selected.

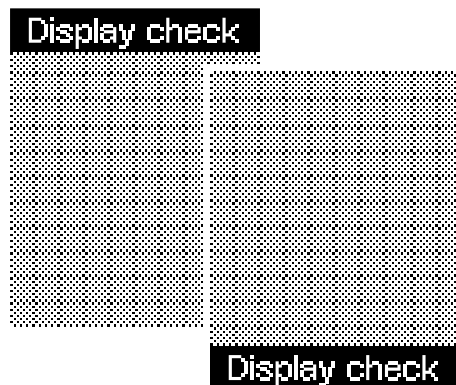

The meter then runs a display check in which a black and yellow checkerboard pattern of small illuminated dots is displayed.

- 5 Check whether there are any irregularities in the checkerboard pattern.

Some examples of irregularities in the checkerboard pattern are shown in Chapter 9.



If there are irregularities in the checkerboard pattern, results might not be displayed correctly. In this case, ask your dealer to change the meter or contact your customer support and service centre.

The meter automatically exits the display check after about 2 seconds.

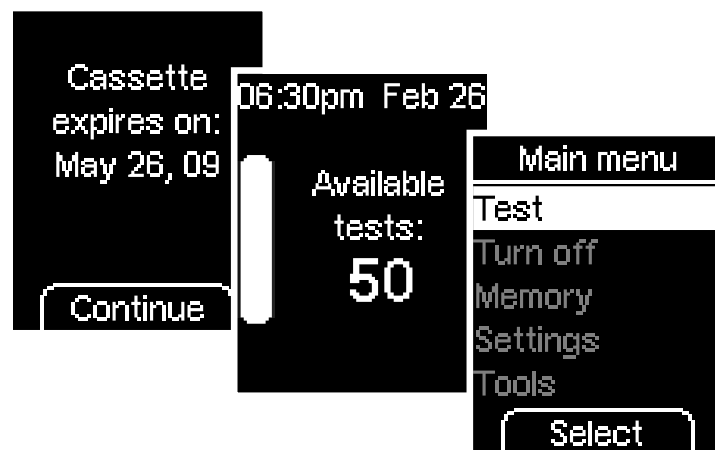

It will then display when the cassette expires.

6 Press the  button (*Continue*).

The meter displays the number of available tests in the test cassette which can still be used for testing.

Then the Main menu is displayed.

Now you can choose what you want to do, e.g:



- perform a blood glucose test

Press  (*Select*).

- turn off the meter

Use   to select *Turn off* → press .

- make settings

Use   to select *Settings* → press  to open *Settings*.

3 Testing blood glucose

When you have inserted a test cassette, removed the protective film from the display and the protective strip from the batteries and set the language (see Chapter 2), you can perform blood glucose tests with the meter.

The time and date are already set in the meter. If these differ from the current time or date you can correct either of these (see Chapter 4).

If you want to use certain functions of the meter, e.g. set reminders to remind you to test, you can change the meter's settings before you start to test or at any other time (see Chapter 4).

To perform a blood glucose test, you only need:

- the meter with inserted test cassette
- the lancing device with inserted lancet drum

3.1 Preparing the lancing device



AST cap

You can use the lancing device to obtain blood from a fingertip or from other (alternate) sites. You can choose one of 11 different penetration depth settings to suit your own skin type.

You can use the lancing device either docked on to the meter or separately from the meter.

If you wish to obtain blood from alternate sites (such as the ball of the thumb, forearm, upper arm, calf or thigh), you must replace the normal black cap on the lancing device with a special transparent AST cap (AST stands for alternate site testing). If there is no AST cap in the pack, you can order one from your customer support and service centre.

Make sure you also read the instructions for use that come with the AST cap before using blood from alternate sites for a blood glucose test.



The lancing device is intended for personal use only!

It may only be used by one person for obtaining blood. There is a risk of infections being transmitted if the lancing device is used by other people, or if healthcare professionals use this lancing device to obtain blood from more than one person. This lancing device is therefore not suitable for professional use in healthcare facilities or institutions.



Wear can lead to material failure. In extreme cases a lancet can protrude from the cap so that injury cannot be completely ruled out. You should therefore handle the lancing device with particular care once a lancet drum has been inserted.



Only use the Accu-Chek FastClix Mobile lancing device with Accu-Chek FastClix lancet drums. Using any other lancets or lancet drums may damage the lancing device or impair its function.



A lancet drum that has been taken out of the lancing device has a built-in safety feature that stops you from using it again. This rules out a potential infection risk.



A locking mechanism prevents the lancet drum being rotated further if there is a 1 in the window showing the number of available lancets. Do not force the lever beyond this locking mechanism as this will damage the lancing device.

Inserting a lancet drum



To use the lancing device to obtain blood, you must first insert a lancet drum.

1 Take a new lancet drum.

You can tell that a lancet drum has been used because it has a red line visible on the white portion. You cannot insert a used lancet drum again.



2 Remove the cap from the lancing device.



- 3** Insert the new lancet drum – white end first – into the lancing device.

The lancet drum is properly inserted when it slots into position with an audible **CLICK**.



- 4** Place the cap back on again.

The cut-out section at the edge of the cap must fit over the correspondingly shaped curvature with the penetration depth indicator (silver line). You must hear and feel the cap click into place. The window showing the number of available lancets shows 6, i.e. there are now 6 lancets available.

Setting the penetration depth

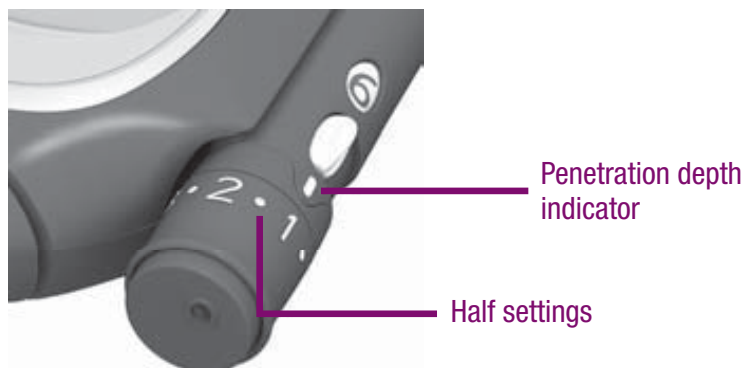

You can set the penetration depth of the lancet to 1 of 11 possible settings (0.5–5.5). The silver line (penetration depth indicator) on the lancing device indicates the current penetration depth setting. The higher the number the deeper the penetration. The half settings for the penetration depth are indicated by a dot. The penetration depth 1.5 is set when the line points to the dot between 1 and 2.

If you have no experience of using this lancing device, we recommend that you start with a low penetration depth setting such as 1.



- 1 Rotate the cap of the lancing device until the desired penetration depth is level with the indicator.

i Do not lance your finger until you are told to do so in the further course of the User's Manual.

Loading a new lancet

You do not need to load a new lancet if you just inserted a new lancet drum.

If you have already used the lancing device to obtain blood, you will need a new lancet the next time you obtain blood. For this, the lancet drum must be rotated in the lancing device.

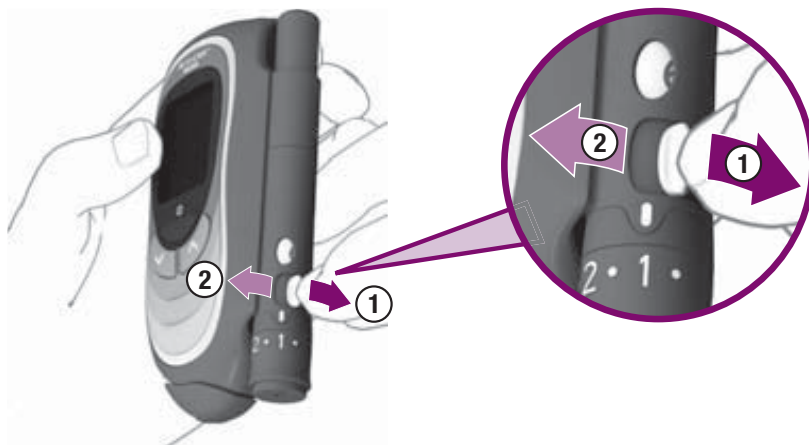

Push the lever at the side of the lancing device to the right as far as it will go (1) and then back to the left (2).

The lancet drum rotates a little further and the next lancet will be advanced to the correct position and is now ready for use.



The window on the side of the lancing device now shows one less available lancet, e.g. 5 instead of previously 6. When you have loaded the sixth and last lancet, the window shows 1.

Replacing a used lancet drum

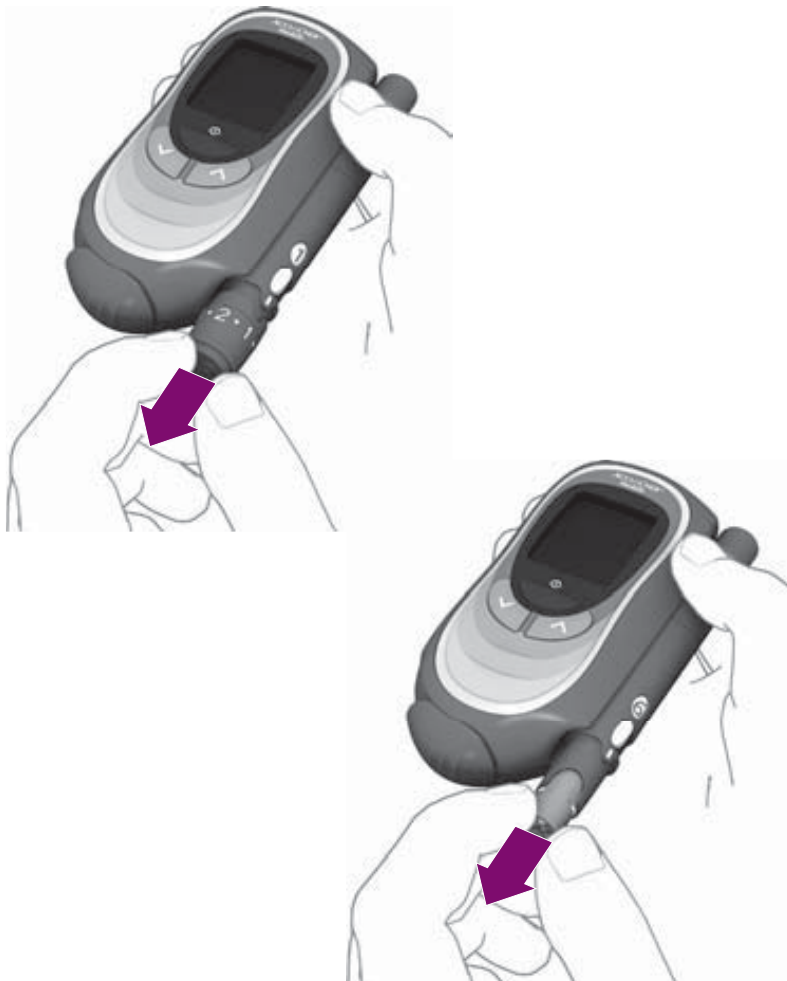

When you have used the sixth and last lancet, you need to replace the used lancet drum with a new one.

1 Remove the cap from the lancing device.

2 Grasp the lancet drum at the cut-outs on the lancing device.

3 Pull the lancet drum out of the lancing device.

Used lancet drums can be disposed of in household waste.

4 Insert a new lancet drum (see section “Inserting a lancet drum”)

Undocking and docking the lancing device

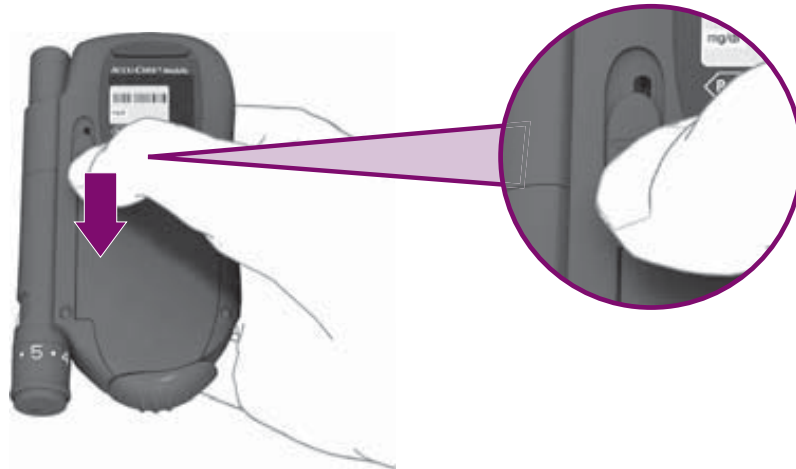

If you wish to use the lancing device separately from the meter, detach it as follows.

- 1** Push the release button for the lancing device (on the back of the meter) in the direction of the arrow as far as it will go. Hold it in this position until you have undocked the lancing device.



- 2** Withdraw the lancing device by sliding it out in the direction of the arrow.



To dock the lancing device on to the meter again, proceed as follows:

There are 2 guide tracks on the meter and the lancing device, respectively. When docking the lancing device, the tracks on the lancing device must fit into the tracks in the recess at the side of the meter.

- 1 Position the lancing device at the lower end of the recess with the multifunction button at the top and the writing "Accu-Chek FastClix Mobile" facing the meter.
- 2 Slide the lancing device along the side of the meter in the direction of the arrow until it slots into place with an audible CLICK.

3.2 Performing a blood glucose test

When you have inserted a lancet drum into the lancing device and set the penetration depth, you can now start to perform a blood glucose test.

There are two ways of starting a blood glucose test.

- You can open the tip cover (with the meter on or off).
- You can turn on the meter using the  button and select Test in the Main menu.

After performing the test, you can flag the result if the test was performed under special conditions and you want to record this.

 Before you start the test, wash your hands with warm water and soap and dry them well. This helps remove any residues from the skin, e.g. from food, drinks or skin cream, which can disturb the test. This also stimulates blood flow and reduces contamination of the puncture site.

 At a particular time, the meter prompts you to apply blood. You then have about 2 minutes to obtain a blood drop and apply it to the test area. If you do not apply blood to the test area within this period, the meter turns off. The test area that had been made available will be lost as the meter will advance a new test area next time.

Starting a blood glucose test by opening the tip cover



- 1 Place your finger on the corrugated area on the tip cover and push it in the direction of the arrow as far as it will go.

After overcoming a slight resistance, the tip cover clicks into place.



Be careful not to touch the tape when doing this as this could damage it.

If the meter was turned off, it now turns on.

Display check

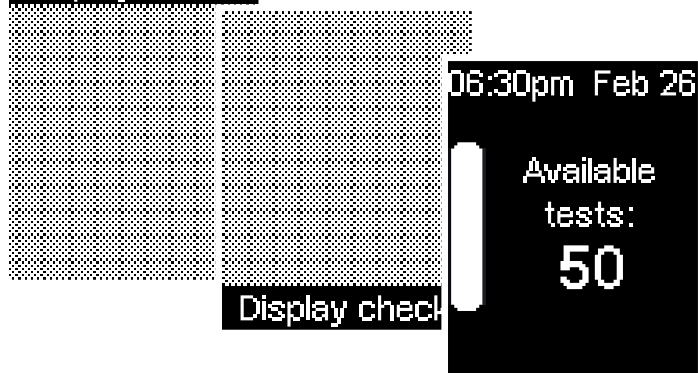

A beep will sound (if *Beeper* is turned on) and the display check will be displayed, followed by the number of available tests.

- 2 Check that there are no irregularities in the checkerboard pattern.

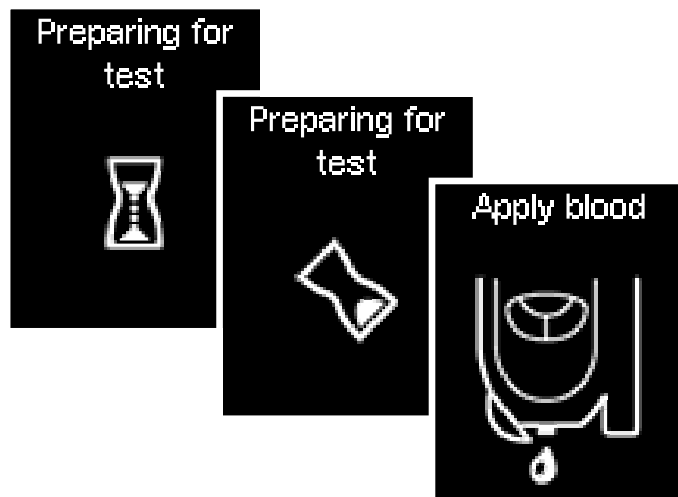

Then the meter will advance a test area to the tip of the cassette.





Be careful not to touch the tape when doing this as this could damage it.

Shortly after the test area has been advanced to the tip of the cassette, the prompt *Apply blood* will appear and a beep will sound again (if *Beeper* is turned on).

You can also open the tip cover if the meter is already turned on. In this case, the meter then switches to *Test*. It advances a test area to the tip of the cassette and then the prompt *Apply blood* appears.

There are the following exceptions:

- If you are in the *Settings* menu. In this case, when you open the tip cover you will be asked whether you really want to perform a test (see Chapter 16.2).
- If you had turned on the meter using the  or  button (see Chapter 5.1 and 13). In this case, the meter does **not** switch to *Test*. You must first turn off the meter. Then you can start the blood glucose test either by opening the tip cover or via the *Main* menu (see next page).

Starting a blood glucose test via the Main menu



- 1 Turn on the meter with ,
→ wait for the *Main menu*.

If the meter is already on:

- 1 Switch from the currently displayed menu to the Main menu.

- 2 Use   to select *Test*,
→ press  to open *Test*.

The prompt *Open tip cover* appears on the display.

If you do not want to perform a test after all, press the  button (*Cancel*). In this case, no test area will be advanced and the number of available tests remains the same. The meter returns to the Main menu.



3 Place your finger on the corrugated area on the tip cover and push it in the direction of the arrow as far as it will go.



Be careful not to touch the tape when doing this as this could damage it.

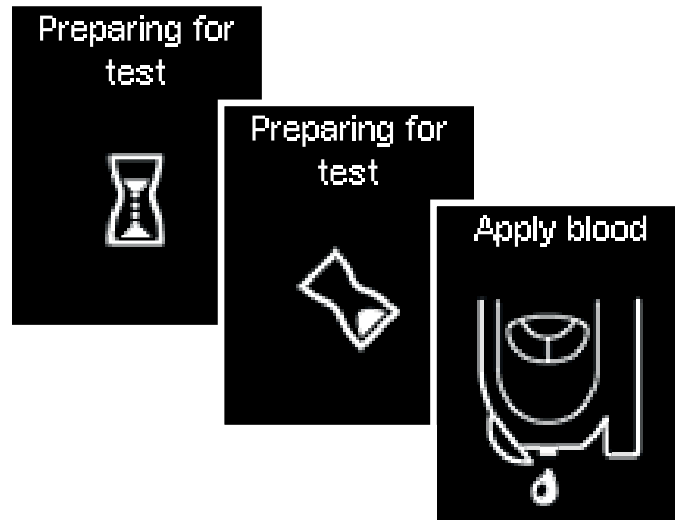

When you have opened the tip cover, the meter advances a test area to the tip of the cassette.



Be careful not to touch the tape when doing this as this could damage it.

Shortly after the test area has been advanced to the tip of the cassette, the prompt *Apply blood* will appear and a beep will sound again (if *Beeper* is turned on).

Obtaining a blood drop



Use a new lancet each time you obtain blood. This reduces the risk of infection and helps ensure virtually pain-free blood sampling.



● = Recommended sites for obtaining blood

In general, all the fingers are suitable for obtaining blood. Certain fingers can be unsuitable if, for example, a skin or fingernail infection is present. We recommend obtaining capillary blood from the side of a fingertip as this registers the least pain (see black areas in the illustration on the left).

The amount of blood that emerges at the puncture site depends on the penetration depth setting and the pressure used to hold the lancing device against the skin.

- If you find when you perform the test that the amount of blood is insufficient, press the lancing device more firmly against the skin next time. If you still obtain insufficient blood, also increase the penetration depth one setting at a time when you perform your next tests.
- If, on the other hand, you obtain too much blood, reduce the penetration depth next time.

To obtain blood with the lancing device, you first need to prime it.



Do not prime the lancing device until you are ready to obtain blood. Storing the lancing device in this primed state can cause parts to become misshapen through tension, impairing its operation.



- 1 To prime the lancing device, press the multifunction button down as far as it will go.

When you release the button one third will come out again. The lancing device is now primed.



Do not press the multifunction button again until you actually want to obtain blood. As the lancing device is now primed, this would trigger the lancet and could lead to accidental injury



 The cap must be on the lancing device when you obtain blood. Without the cap, the lancet would penetrate too deeply and you would feel more pain than necessary.

2 Press the lancing device **firmly** against the chosen puncture site.

You will feel a slightly raised ring against your skin; this is the pin-hole through which the tip of the lancet emerges.

3 Press the multifunction button all the way down.

This triggers the lancet, which penetrates the skin to the penetration depth set.

4 If necessary, gently massage the finger in the direction of the fingertip to encourage a blood drop to form.

Applying the blood drop to the test area

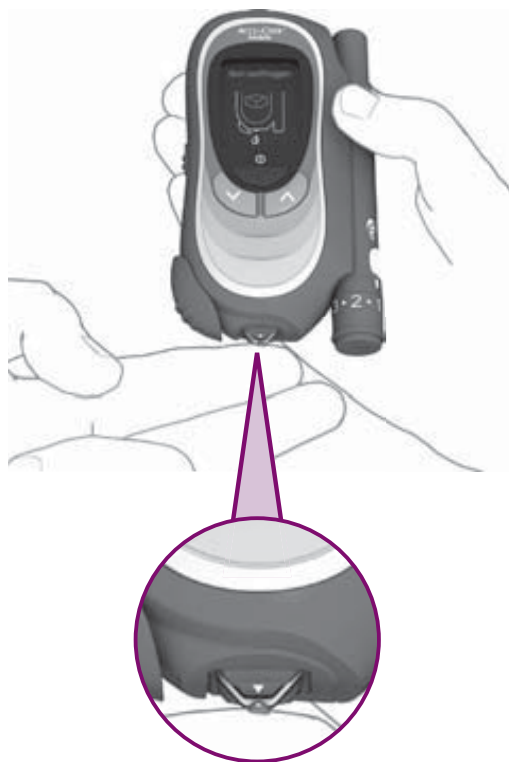

Do not apply blood at the edge of the test area



Do not hold the meter with the test area pointing upwards

You can hold the meter in your hand or lay it down while you apply blood to the test area.



Do not hold the meter with the test area pointing upwards. If you hold the meter with the test area pointing upwards, blood could enter the meter and soil it.

When the prompt *Apply blood* is displayed:

- 1 As soon as the blood drop has formed, bring it towards the **centre** of the test area at the tip of the cassette.

Touch the tape **lightly** with your finger. The blood drop is drawn up by the test area.

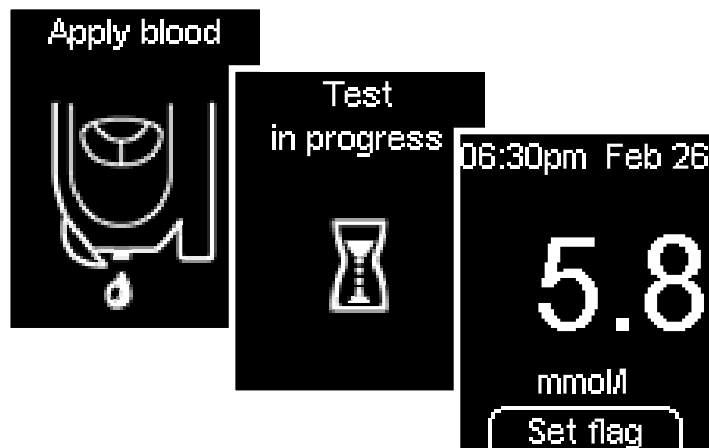

- 2 Take your finger away from the test area as soon as *Test in progress* and the hourglass symbol appear on the display.

The test area has then drawn up enough blood and a beep sounds (if *Beeper* is turned on). The hourglass symbol indicates that the test is in progress.

Testing is complete after approx. 5 seconds. The result appears on the display and the meter beeps (if *Beeper* is turned on). At the same time the meter automatically saves the result. The used test area is transported away from the tip of the cassette.

If you want to flag the result do not turn the meter off. The procedure for flagging results is described under “Flagging results”.

If you do not wish to flag the result you can now turn off the meter (see next page).

Turning off the meter



Turning off via the tip cover

- 1 Close the tip cover.

The meter displays the number of available tests and then turns off.

- i** The result will be displayed for at least 15 seconds. If you close the tip cover before the end of this time, the result will continue to be displayed. The number of available tests does not appear until the 15 seconds have elapsed.



Press and hold
button
to switch off
meter



Press and hold
button
to switch off
meter



Available
tests:
49



Turning off using the On/Off button

- 1 Press and hold the On/Off  button until the bar on the display is filled (at least 2 seconds).

Before the meter turns off, it prompts you to close the tip cover and then display the number of available tests for your information.

- 2 Close the tip cover.

Symbols which are displayed together with the result

The following symbols can be displayed together with the result:



The batteries are almost empty.



The temperature during the test was outside the permitted range of +10 to +40 °C. Despite a warning to this effect you decided to go ahead with the test.



You have turned on the target range. The result is either below the lower limit or above the upper limit of the target range set.

LO

in place of a result: The result is lower than 0.6 mmol/l.



LO may indicate that your blood glucose is very low (possibly a severe hypoglycemia). Follow the relevant instructions given by your doctor immediately and repeat the test.

HI





in place of a result: The result is higher than 33.3 mmol/l. Repeat the test.

Flagging results

You can flag results to describe certain events connected to the result or particular characteristics of the result. You can only flag a result if you open the *Set flag* menu while the result is still displayed after a test.



The *Set flag* menu offers you a choice of 4 flags:

- *Control test* (symbol ) is intended for control tests in which you apply control solution to the test area instead of blood.
- *General* (symbol ): You can define the meaning of this flag yourself. For example, you can use it for results that you have obtained from alternate sites or after physical activities.
- *Before meal* (apple symbol ) is intended for results you have obtained before your meals.
- *After meal* (bitten into apple symbol ) is intended for results you have obtained after your meals.

In addition to the 4 flags, the last item in the *Set flag* menu is *Reminder*. You can use this to go directly to the *Reminders* menu after a test.

You can add the following flags to a result together:

- *General* and *Before meal*
- *General* and *After meal*

You cannot flag a result with *Before meal* and *After meal* together. If either of these flags is already set, it will automatically be removed when you set the other flag.

You can change (add or remove) flags again as long as you are still in the *Set flag* menu. As soon as you leave the menu, either by going to the Main menu, selecting *Reminder* or *Control test* or turning off the meter, the flags chosen will be saved and can no longer be subsequently changed.

Reminder allows you to go directly from the *Set flag* menu after a test to set a reminder if you would like to check your blood glucose again later. You do not need to go to the Main menu or turn the meter off and on again but just select *Reminder*.

If you want to flag a result and set a reminder, you have to set the flag(s) first. Selecting *Reminder* takes you out of the *Set flag* menu and opens the *Reminders* menu.

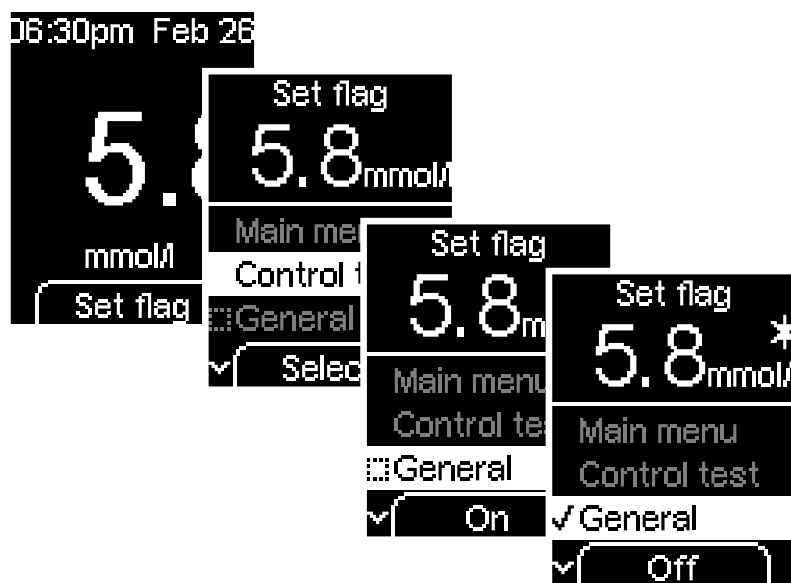

Selecting *Control test* also takes you out of the *Set flag* menu and opens the *Control solution* menu.





The following descriptions start from the display of a result after a test.

General, Before meal and After meal

1 Press  (*Set flag*).

This opens the *Set flag* menu. All flags are deactivated. A checkbox  indicates that the flag is deactivated, a tick  that it is activated.

2 Use   to select *General, Before meal* or *After meal*.





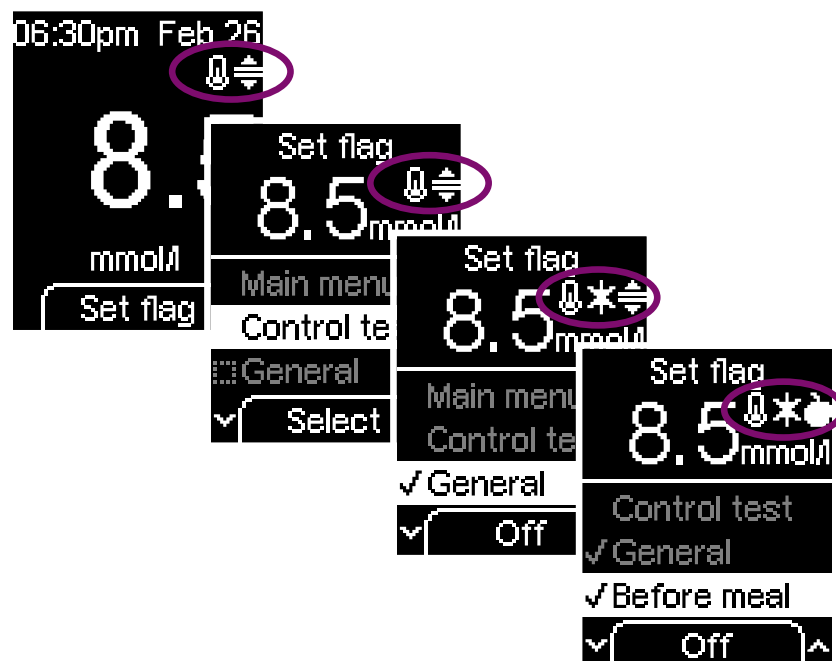

3 Press the  button (*On*).

The symbol for the flag that has been activated is displayed to the right of the result.

If you want to add a further flag to the result, repeat steps 2 and 3.





3 symbols can be displayed to the right of the result. If a result is flagged with 4 symbols, the symbol  will not be displayed.

Example: If the temperature during a test was too high or too low and the test is outside the target range, the result will automatically be flagged with the symbols  and  (see Chapter 16.2 and 4.6). If you flag this result with *General* and *Before meal*, the symbols  will be displayed next to the symbol  and , and the symbol  will no longer be displayed (however, the flag will not be removed).



Removing a flag again:

- 1 Use   to select *General*, for example.
- 2 Press the  button (*Off*).





or



Leaving the *Set flag* menu

1a Turn off the meter with .

or





1b Use  to select *Main menu* and press  (*Select*).

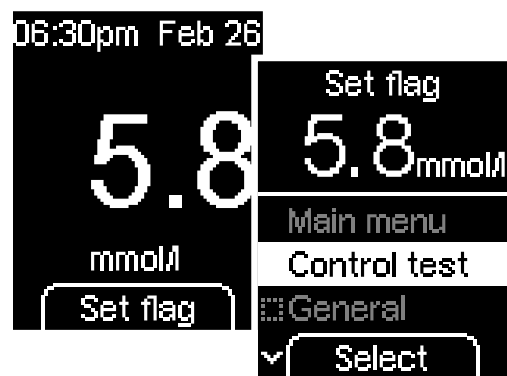

2 Close the tip cover.







Reminder

- 1 Press  (*Set flag*).
- 2 Use   to select *Reminder*.
- 3 Press  (*Select*).

This opens the *Reminders* menu. You will find all the information about this menu in Chapter 4.5.

Control test

- 1 Press  (*Set flag*).
- 2 Use   to select *Control test*.
- 3 Press  (*Select*).

The further procedure for performing a control test (test with control solution) is described in Chapter 7.2.

3.3 Evaluating results



If the displayed result agrees with the way you feel, follow the instructions given by your doctor. If the displayed result does not agree with the way you feel, perform a control test with an Accu-Chek Mobile control solution (see Chapter 7). Then repeat the blood glucose test. If the new result still does not agree with the way you feel, contact your doctor.



Do not change your treatment based on just one result.

Measuring range

The meter measures blood glucose results in the range from 0.6–33.3 mmol/l.

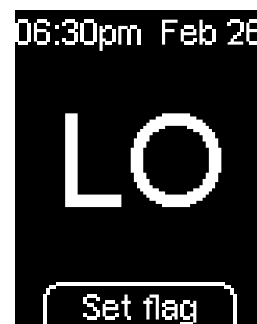

If the result is lower than 0.6 mmol/l, **LO** is displayed instead of a result.



LO may indicate that your blood glucose is very low (possibly a severe hypoglycemia). Follow the relevant instructions given by your doctor immediately and repeat the test.



If the result is higher than 33.3 mmol/l, **HI** is displayed instead of a result. Repeat the test.

Implausible results – possible sources of error

If your meter repeatedly displays implausible results or error messages, please check the points listed below.

If any of your responses to the questions listed differ from those given, make the respective corrections when you perform the next test. If you have taken all of these points into account and still obtain implausible results or error messages, contact your customer support and service centre.

Did you perform the blood glucose test according to the User's Manual?	yes
Did you wash your hands with warm water and soap? Did you dry your hands well?	yes
Did you massage your finger only gently in the direction of the finger tip?	yes
Did you wait for the application prompt to be displayed before applying blood?	yes

Did you apply the blood drop to the test area immediately after it had formed?	yes
--	-----

Did you perform the test within the correct temperature range (10–40 °C)?	yes
---	-----

Did you observe the proper storage conditions for the meter and the test cassette (see Chapter 15 and the test cassette package insert)?	yes
--	-----

Have you paid attention to the sources of error stated in the test cassette package insert?	yes
---	-----

If your meter has been dropped, that can also lead to implausible results or error messages. In this case, you should also call your customer support and service centre.

4 Making settings

4.1 Settings overview

The meter has several features which you can only use after making the appropriate settings. Most of these features are intended primarily to enable you to adapt the meter to your personal needs (e.g. beeper and acoustic reminders).

An overview of the settings is given on the following 2 pages. The respective default settings with which the meter is delivered are shown in each case.

You can perform blood glucose tests without adjusting any of the settings on the meter. In this case, all the settings are the default settings.

Menu	Setting	Available options	Default setting
Time/Date	Time		Central Standard Time (CST)
	Date		Current date
	Time format (format for time and date)	hh:mm * hh:mm hh:mm hh:mm am/pm hh:mm am/pm hh:mm am/pm hh:mm am/pm hh:mm	DD.MM.YY ** Day DD.MM. DD. Month MM/DD/YY MM/DD Month DD DD. Month YY/MM/DD





* hh = hours, mm = minutes; e.g. 09:45 (hh:mm)

** DD = day, MM = month, YY = year; e.g. 25.11.09 (DD.MM.YY) or 11/25/09 (MM/DD/YY)

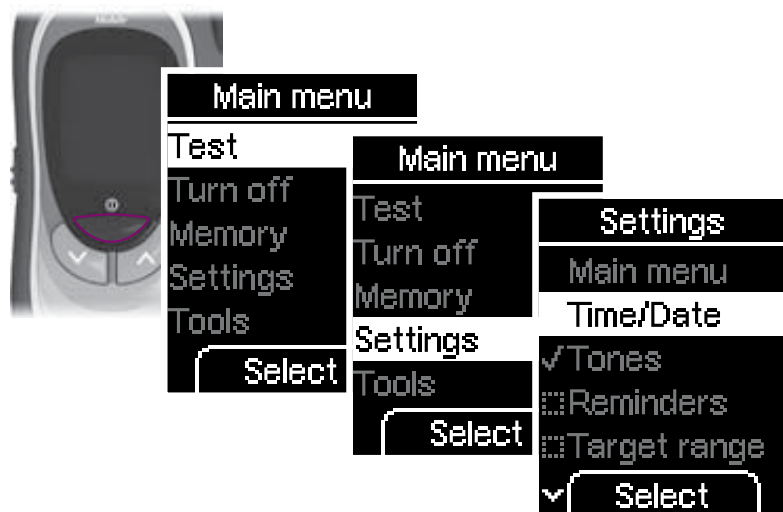
Menu	Setting	Available options	Default setting
Tones	Beeper	On or Off	On
	Reminders	Beeper On or Off	On
	Acoustic mode	On or Off	Off
Reminders		10 times – freely selectable daily reminders and/or a single reminder after a specified length of time (1, 2 or 3 hrs)	None
Target range		Lower and upper limit value / On or Off	None / Off
Volume		5 levels	Level 3
Brightness		3 levels	Level 2
Language		15 different languages	English US

4.2 Opening the Settings menu



- 1 Turn on the meter with ,
 - wait for the *Main menu*,
 - use   to select *Settings*,
 - press  to open *Settings*.

The buttons to use for making settings are described in Chapters 1.5 and 1.9.

You will find a complete overview of the menus at the end of the User's Manual.

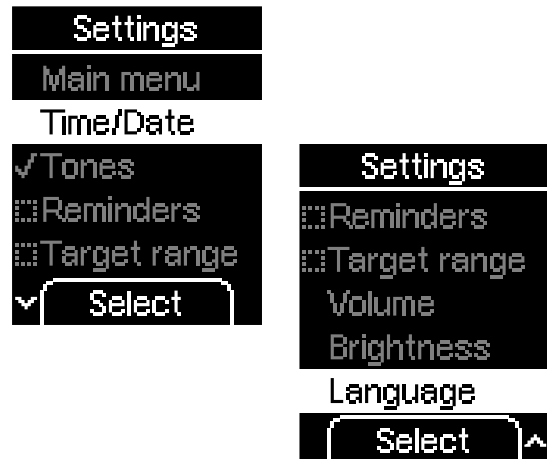

Im Menü *Einstellungen* finden Sie folgende Auswahlmöglichkeiten:

- *Hauptmenü*: zum *Hauptmenü* gehen
- *Zeit/Datum*: Uhrzeit und Datum einstellen, Zeitformat auswählen
- *Töne*: Signaltöne, Erinnerungen und Akustikmodus ein- oder ausschalten
- *Erinnerungen*: Erinnerungszeiten einstellen
- *Zielbereich*: Ober- und Untergrenze für den Zielbereich einstellen
- *Lautstärke*: Lautstärke der Signaltöne einstellen
- *Helligkeit*: Helligkeit der Anzeige einstellen
- *Sprache*: Sprache der angezeigten Texte auswählen

4.3 Setting the time and date, selecting the time format

The time and date are already set in the meter. If you want to use reminders or analyse your results with a computer, for example, you should check the time and date and correct them if they deviate from the current time or date.

- All results are saved together with the time and date. If the time and date are not correctly set, the results cannot be analysed properly as a function of time.
- If the time is not correctly set and you use reminders, you will be reminded to perform a test at the wrong time.









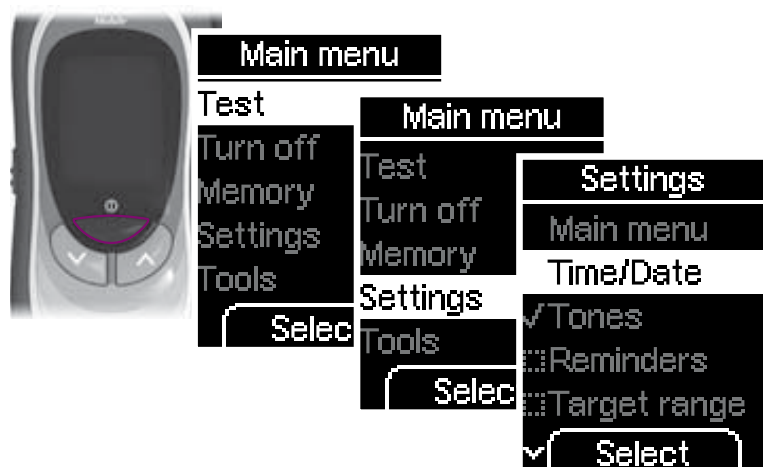



The following options are available in the *Time/Date* menu:

- *Main menu*: takes you to the Main menu
- *Back*: takes you to the Settings menu
- *Time*: set the time
- *Date*: set the date
- *Time format*: select the time format

Setting the time



- 1 Turn on the meter with ,
→ wait for the *Main menu*,
→ use   to select *Settings*,
→ press  to open *Settings*,
→ use   to select *Time/Date*,
→ press  to open *Time/Date*,
→ use   to select *Time*,
→ press  to open *Time*.



The hours are highlighted.

If you have chosen one of the 12-hour time formats, *am* (morning) or *pm* (afternoon) is also displayed after the time.

24-hour format

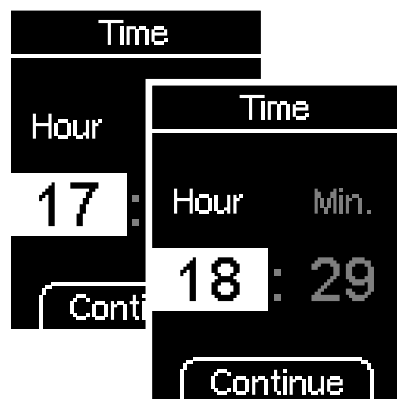

12-hour format

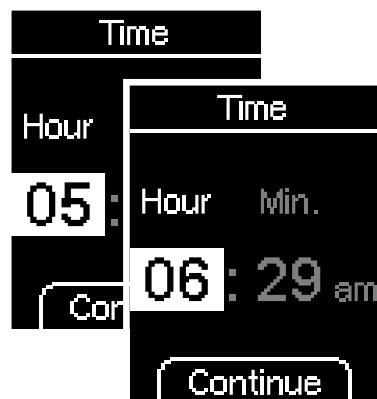

- 2 Use to set the hour.
- 3 Press (*Continue*).

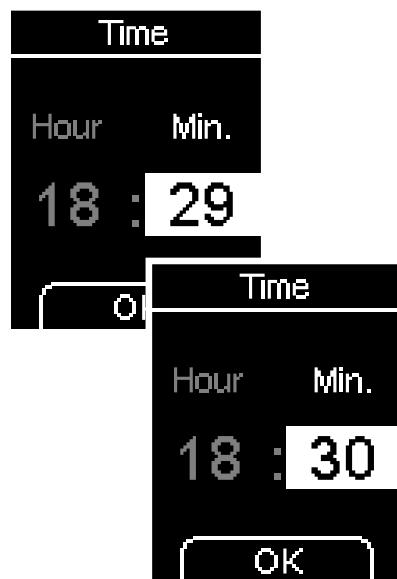

The minutes are now highlighted.

- 4 Use to set the minutes.
- 5 Press (*OK* or *Continue*).

24-hour format

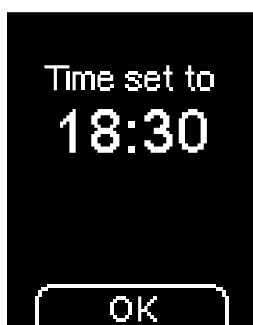

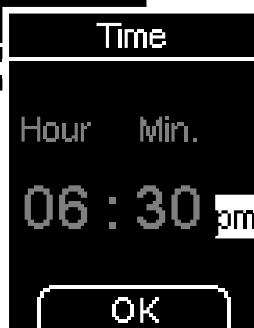

12-hour format



Only for times in 12-hour format:

The suffix *am* or *pm* is highlighted.

5a Use   to select *am* or *pm*.

5b Press  (*OK*).

The meter will then display the time you just set.

6 Press  (*OK*).

The meter returns to the *Time/Date* menu.



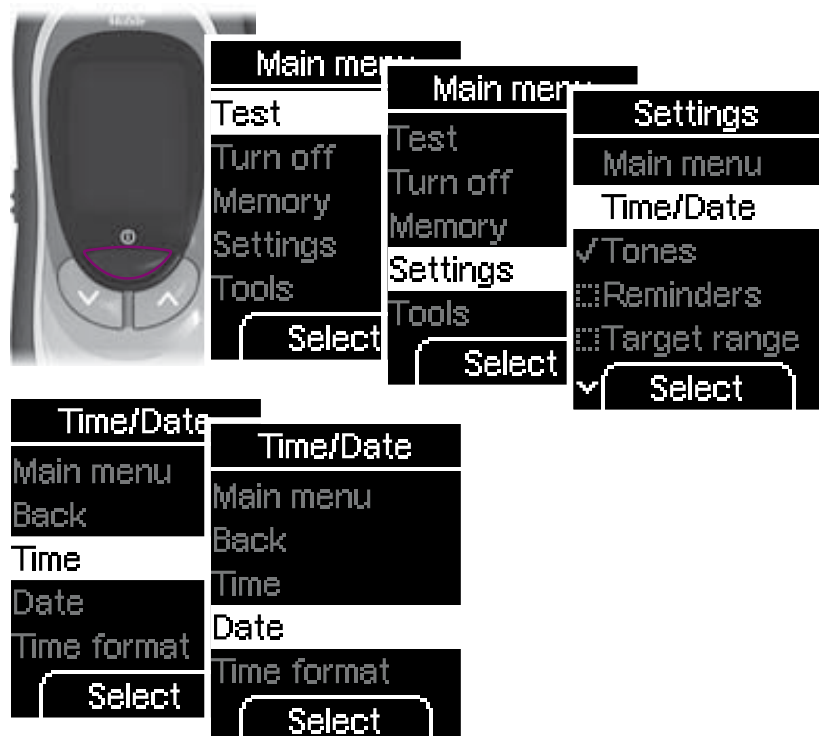
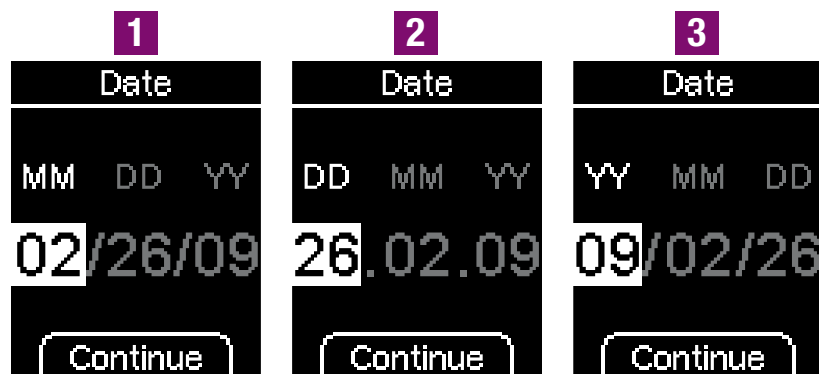







Setting the date



The sequence in which you set the day, month and year while setting the date depends on the time format you have set. Apart from the sequence, the procedure is the same in all cases.

The following sequences are possible:

- 1 Month – Day – Year
- 2 Day – Month – Year
- 3 Year – Month – Day

- 1 Turn on the meter with ,
 → wait for *Main menu*,
 → use   to select *Settings*,
 → press  to open *Settings*,
 → use   to select *Time/Date*,
 → press  to open *Time/Date*,
 → use   to select *Date*,
 → press  to open *Date*.

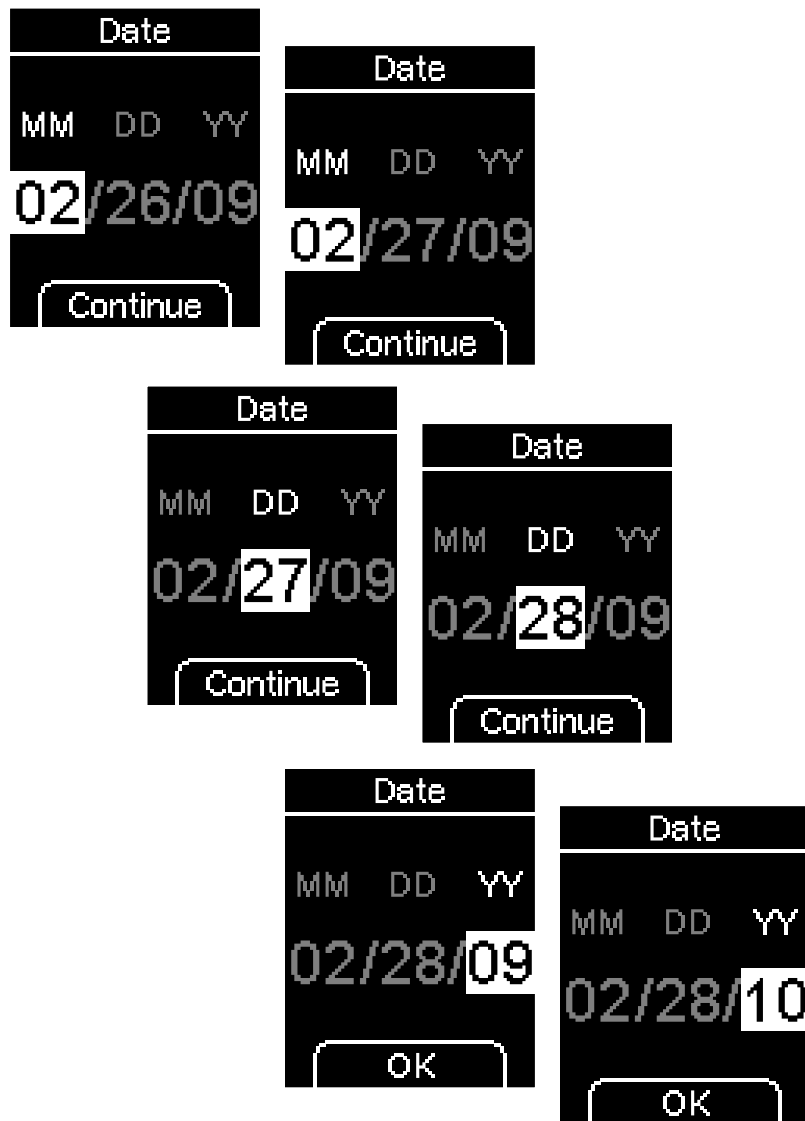

The following example describes the procedure for setting the date in the case of sequence **1**.

The month is highlighted.

- 2 Use to set the month.
- 3 Press (*Continue*).

The day is now highlighted.

- 4 Use to set the day.
- 5 Press (*Continue*).

The year is now highlighted.

- 6 Use to set the year.
- 7 Press (*OK*).

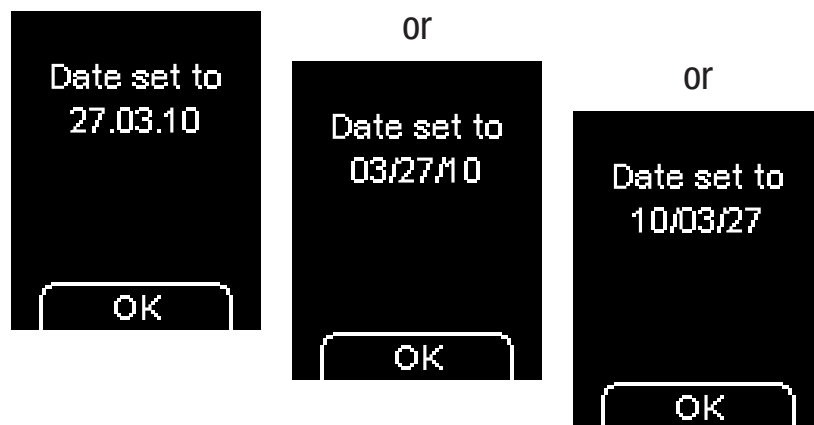

The meter will then display the date you just set. The date will be displayed according to the time format you have set (see examples on left).

8 Press  (OK).









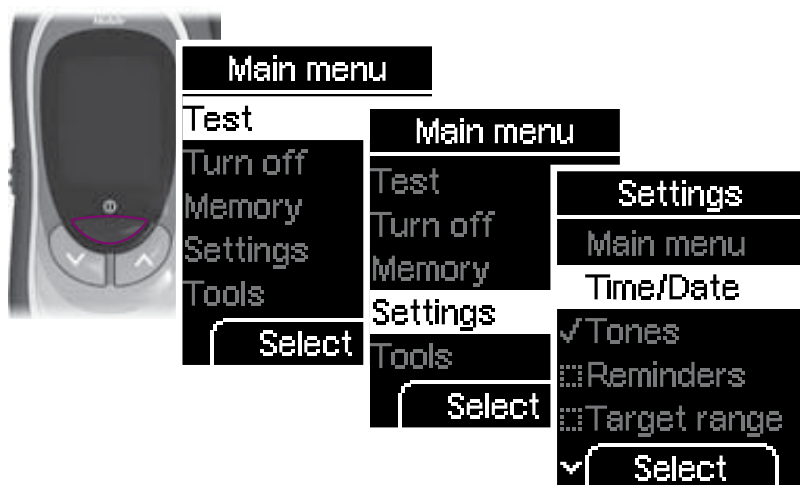

The meter returns to the *Time/Date* menu.



 If the date you have set does not exist (e.g. 31 April), the meter returns to the first setting position when you confirm the last entry with *OK* (step 7). You must correct the date before the meter will accept it.

Selecting the time format



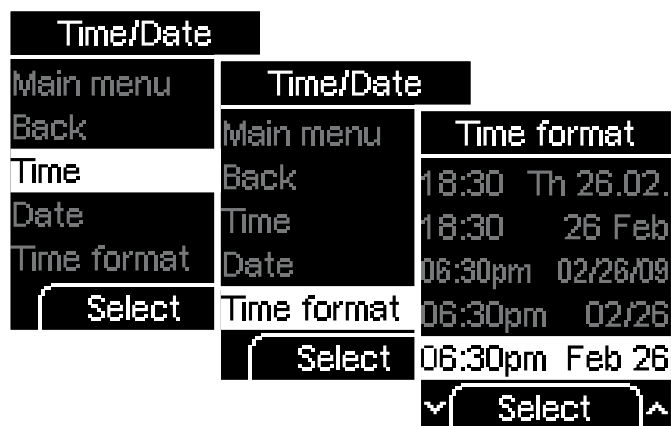

- 1 Turn on the meter with ,
 - wait for *Main menu*,
 - use   to select *Settings*,
 - press  to open *Settings*,
 - use   to select *Time/Date*,
 - press  to open *Time/Date*,
 - use   to select *Time format*,
 - press  to open *Time format*.

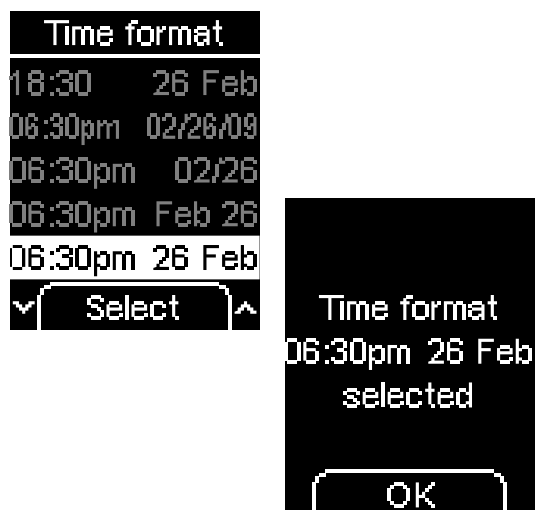

The currently set time format is highlighted.



2 Use   to select the desired time format.

3 Press  (*Select*).

The meter will then display the time format you just set.

4 Press  (*OK*).

The meter returns to the Time/Date menu.

4.4 Setting tones

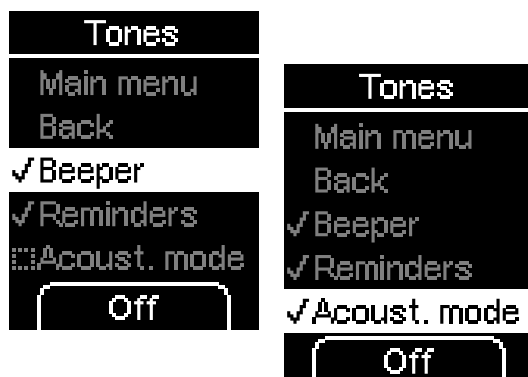

The following options are available in the Tones menu:

- *Main menu*: takes you to the Main menu
 - *Back*: takes you to the Settings menu
 - *Beeper*: turn the beeper on or off
 - *Reminders*: turn the beep tone for reminders on or off
 - *Acoustic mode*: turn the acoustic mode on or off
-
- **Beeper**: If *Beeper* is turned on (default setting), a beep will sound at the following times during a test:
 - when the display check starts,
 - when the prompt *Apply blood* is displayed and you can apply blood or control solution to the test area,
 - when *Test in progress* is displayed and the test begins,
 - when the result is displayed,
 - when an error message is displayed (a double beep 4 times in succession).

Reminders: Here you can set whether or not you want reminders to be accompanied by beeps (see Chapter 4.5). If *Reminders* is turned on (default setting), the beeps will sound.

Acoustic mode: If the acoustic mode is turned on (default setting: off), the meter guides you through the blood glucose test with the beeps described above. At the end of the test, the meter also announces the result in the form of a sequence of beep tones. The acoustic mode is described in Chapter 6.



Visually impaired people should only use the acoustic mode if they have familiarized themselves fully with the acoustic mode with the assistance of a sighted person and have demonstrated that they are able to understand results correctly without exception using the acoustic mode. The acoustic mode should always be used with great care. Otherwise there is a risk that the results will be misinterpreted by the person performing the test. An incorrect insulin dose resulting from a misinterpreted







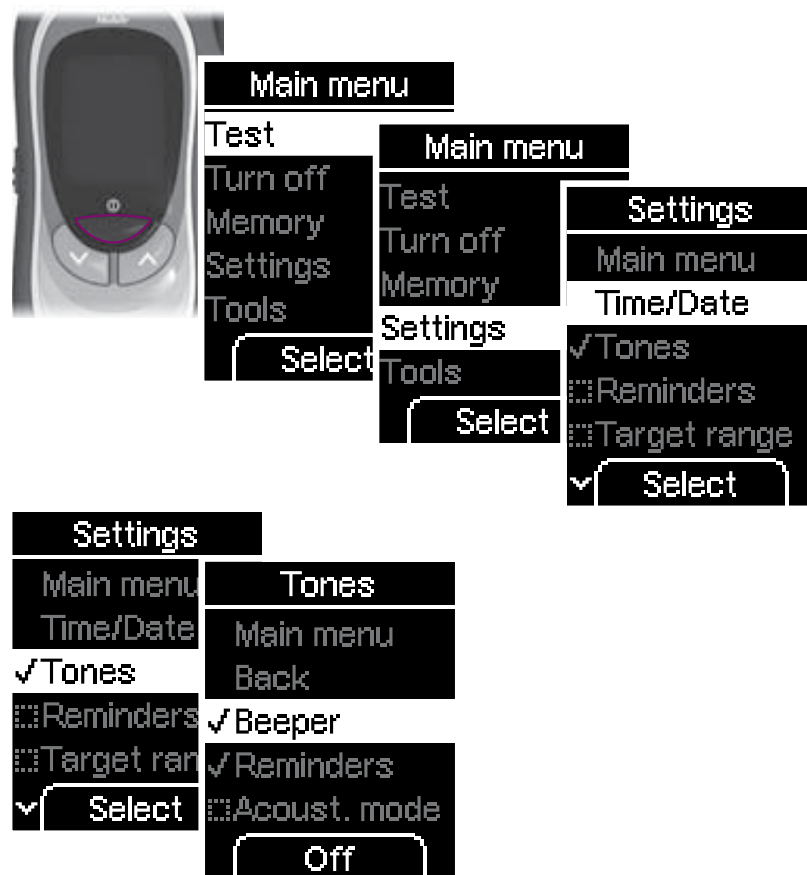

result can cause considerable health damage and can even be fatal. Especially if unexpected and abnormal blood glucose values are obtained using the acoustic mode, the result must be checked by repeating the test together with a sighted person.

Visually impaired people should not test their blood glucose without assistance from a sighted person.

Turning the beeper, reminders and acoustic mode on and off

Beeper, Reminders and Acoustic mode can only be turned on and off. The procedure is always the same and is therefore only described here for *Beeper*.



- 1 Turn on the meter with ,
 - wait for *Main menu*,
 - use   to select *Settings*,
 - press  to open *Settings*,
 - use   to select *Tones*,
 - press  to open *Tones*,
 - use   to select *Beeper* (or another function).

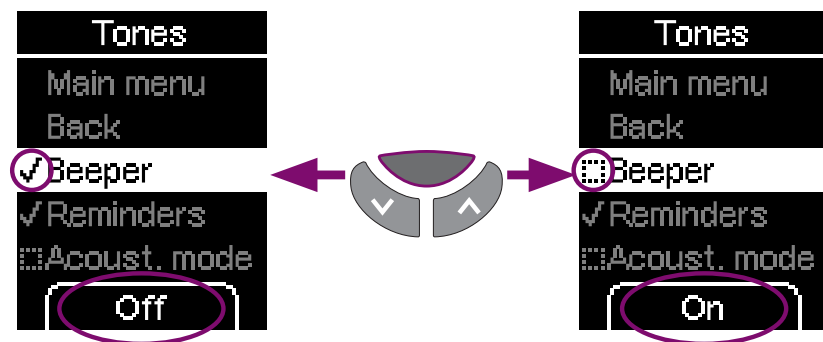

- A tick means that the function is activated
- A checkbox means that it is deactivated

2 Press  (*On or Off*) to turn the beeper on or off.

The meter remains in the *Tones* menu.

 If you wish to use the acoustic mode, you must turn both *Acoustic mode* and *Beeper* on.

4.5 Setting reminders

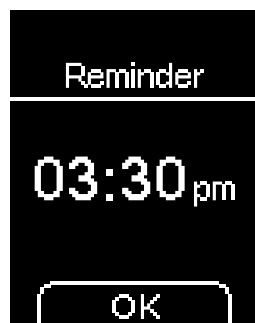

You can set up to 10 reminder times.

If the meter is turned off, “Reminder” and the time of the reminder will be displayed daily at the time you have set. If you have turned on *Reminders* in the *Tones* menu, beeps will also sound.

You can turn off the reminder and the beeps by pressing any button. If you do not press a button, the meter turns off automatically after 20 seconds. The reminder will not be repeated.

If you perform a blood glucose test 10 minutes or less before a reminder, the reminder will not be given.

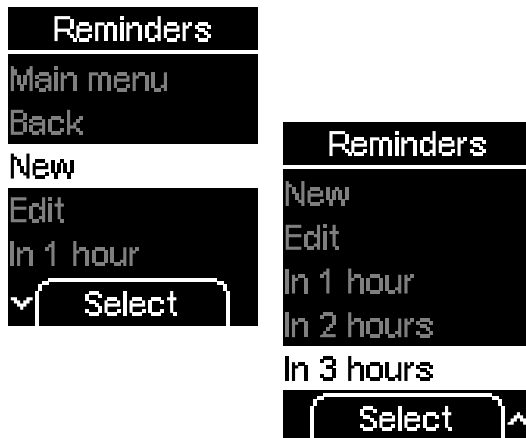

Reminders menu when 10 reminders have already been set.









The following options are available in the *Reminders* menu:

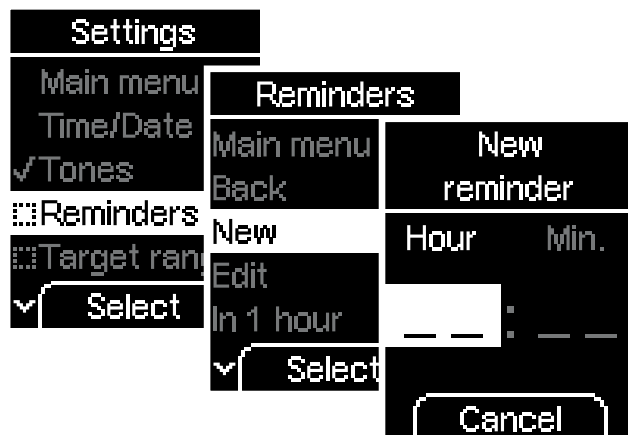
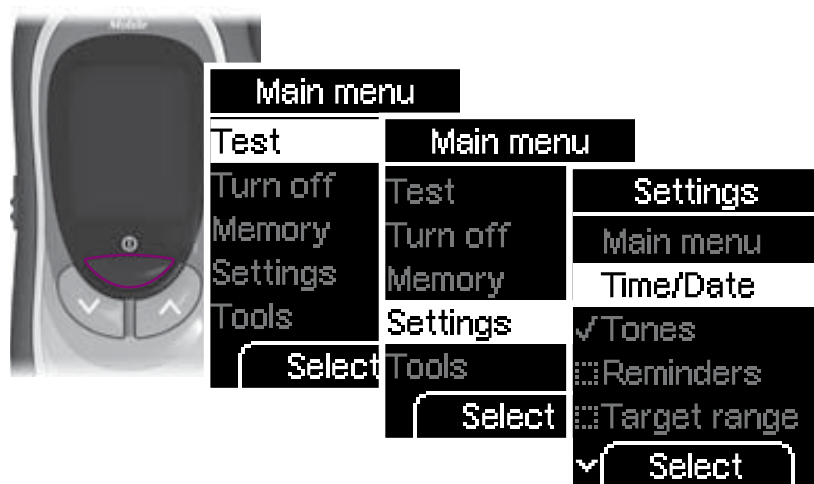

- *Main menu*: takes you to the Main menu
- *Back*: takes you to the *Settings* menu
- *New*: set a new time for a daily reminder
- *Edit*: edit an existing reminder time (is only displayed if at least one time has been set)
- *In 1 hour*: set a single reminder in 1 hour
- *In 2 hours*: set a single reminder in 2 hours
- *In 3 hours*: set a single reminder in 3 hours





New, *In 1 hour*, *In 2 hours* and *In 3 hours* are not displayed if 10 reminder times have already been set.

Setting a new reminder



- 1 Turn on the meter with ,
 - wait for *Main menu*,
 - use   to select *Settings*.
 - press  to open *Settings*,
 - use   to select *Reminders*.

The checkbox  to the left of *Reminders* means that no reminders have been set or that all reminders set have been turned off. A tick  means that at least one reminder has been set and is turned on.

- 2 Press  to open *Reminders*,
 - use   to select *New*,
 - press  to open *New*.

As you are about to set a new reminder time, only dashes are displayed for the hours and minutes.

If you decide you do not want to set a reminder time after all, press the  button (*Cancel*) to return to the *Reminders* menu.

24-hour format

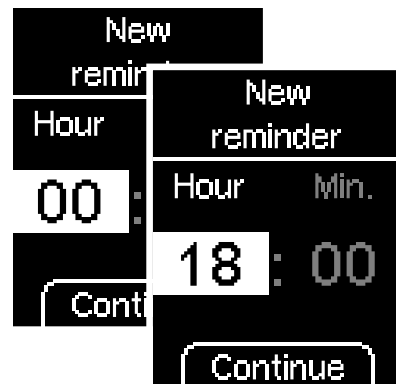

12-hour format

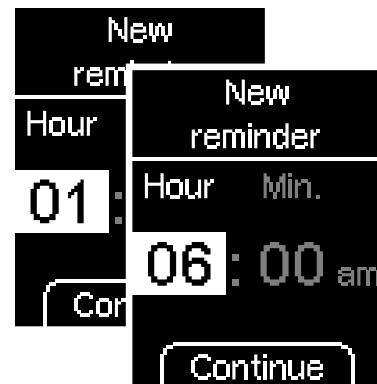

The hours are highlighted.



3 Use   to set the hour.

The first time you press the button, the time will go to 00:00 (24-hour format) or 01:00 am (12-hour format).

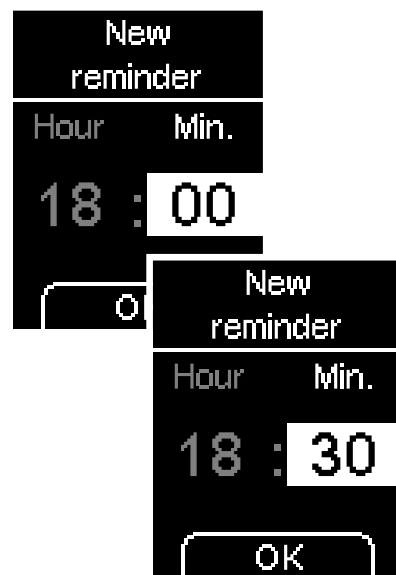
4 Press  (*Continue*).



The minutes are now highlighted.

5 Use   to set the minutes.

6 Press  (*OK* or *Continue*).

24-hour format



12-hour format

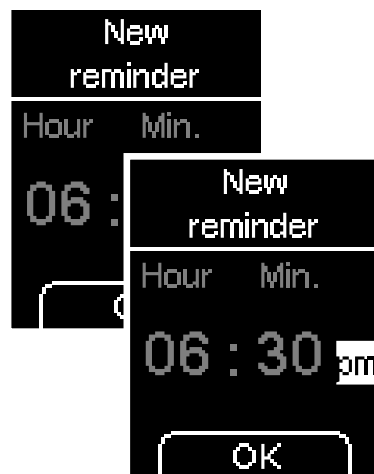

Only for times in 12-hour format:
The suffix *am* or *pm* is highlighted.

6a Use to select *am* or *pm*.

6b Press (OK).









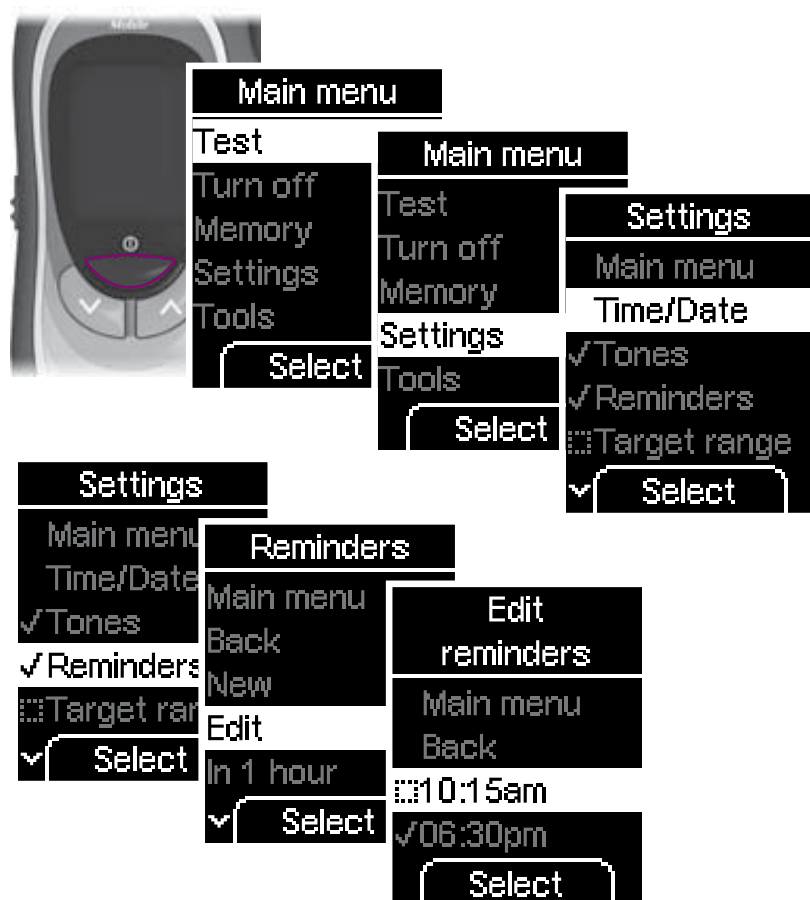

The meter will then display the reminder time you just set. The reminder is also turned on.

7 Press (OK).

The meter returns to the *Edit reminders* menu.



Editing an existing reminder (turn on/off, change, delete)



- 1 Turn on the meter with ,
 → wait for the *Main menu*,
 → use   to select *Settings*,
 → press  to open *Settings*,
 → use   to select *Reminders*,
 → press  to open *Reminders*,
 → use   to select *Edit*,
 → press  to open *Edit*.

A list with the reminders that have already been set appears on the display.

A checkbox  indicates that the reminder is turned off, a tick  that it is turned on.

- 2 Use   to select the reminder time you wish to edit.
- 3 Press  (*Select*).

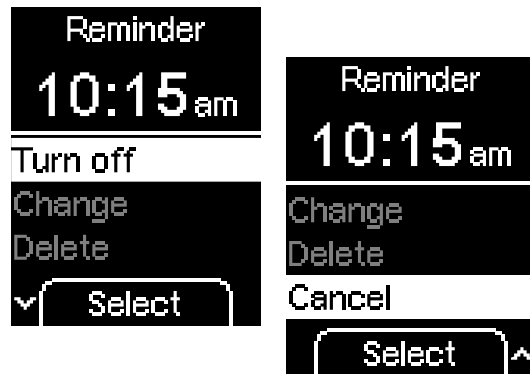



You will then see the following options below the time:

- *Turn off*, to turn off a reminder that is turned on (the time remains unchanged), or *Turn on* to turn on a reminder that has been turned off.
- *Change*, to change the reminder time
- *Delete*, to delete this reminder
- *Cancel*, if you do not wish to edit this reminder

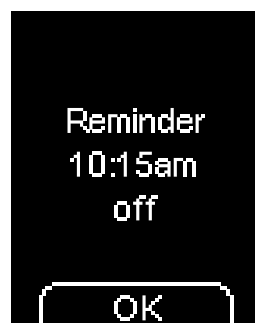
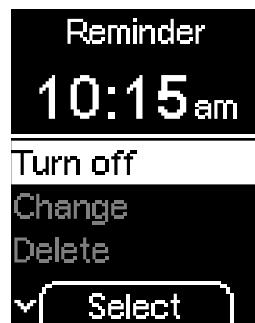
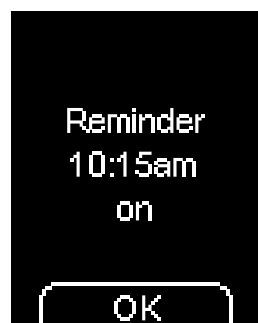
In den folgenden Beispielen werden nur Uhrzeiten im 24-Stunden-Format gezeigt und beschrieben.



Turning a reminder on or off

- 1 Use   to select *Turn on* (*Turn off*).
- 2 Press  (*Select*).

The meter will then display the reminder time you just turned on or off.

- 3 Press  (*OK*).

The reminder is now turned on or off.

The meter returns to the *Edit reminders* menu

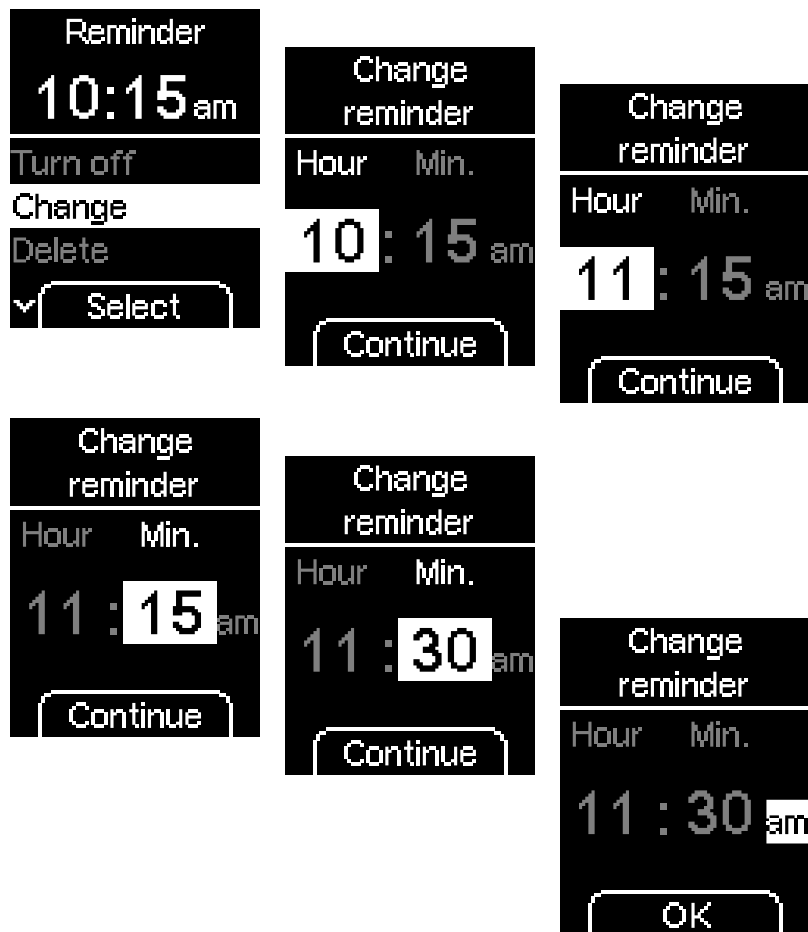

Changing a reminder

- 1 Use to select *Change*.
- 2 Press (*Select*).
- 3 Set the new reminder time (see “Setting a new reminder” for how to do this).

The meter will then display the reminder time you just changed.

- 4 Press (*OK*).

The reminder time has now been changed and the reminder is also turned on.

The meter returns to the *Edit reminders* menu.

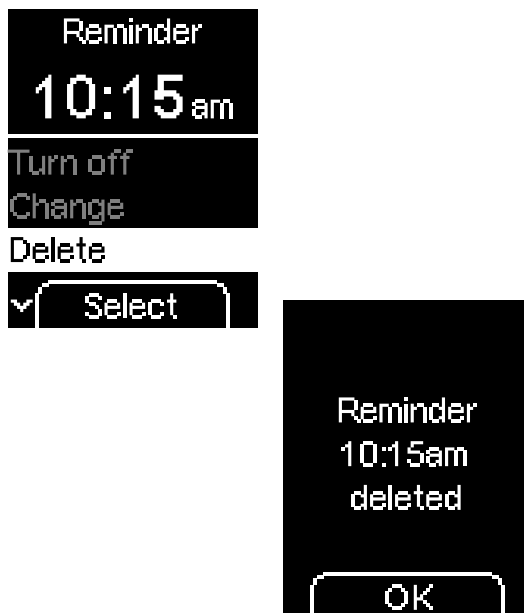

Deleting a reminder

- 1 Use to select *Delete*.
- 2 Press (*Select*).

The meter will then display the reminder time you just deleted.

- 3 Press (*OK*).

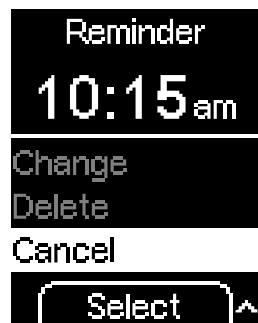

The reminder time has now been deleted.

The meter returns to the *Edit reminders* menu or to the *Reminders* menu if you have deleted the last reminder.



Cancel – Not editing a reminder

If you do not want to edit a selected reminder after all, you can cancel the editing procedure as follows.







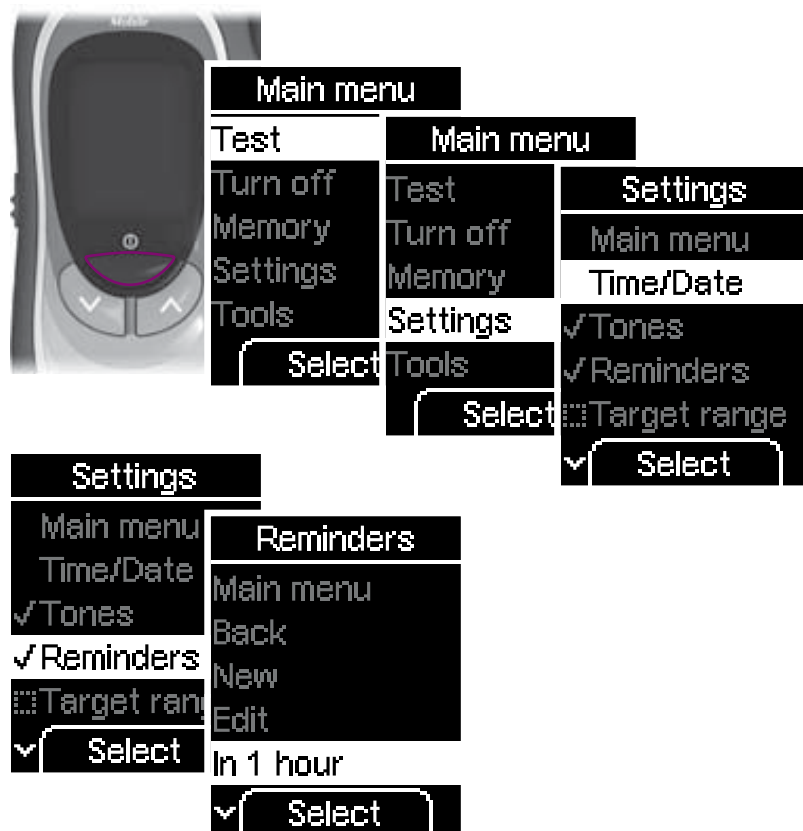



- 1 Use   to select *Cancel*.
- 2 Press  (*Select*).

The meter returns to the *Edit reminders* menu without changing the reminder.

Setting a single reminder in 1 hour, 2 hours or 3 hours



The meter can give you a single reminder to perform a test in 1 hour, 2 hours or 3 hours. You do not need to set a time for this. These reminders can be useful if you wish to check a result you just obtained, for example. When the reminder has been given, it is automatically deleted.

- 1 Turn on the meter with ,
 → use   to select *Settings*,
 → press  to open *Settings*,
 → use   to select *Reminders*,
 → press  to open *Reminders*,
 → use   to select *In 1 hour*
 (or *In 2 hours* or *In 3 hours*).
- 2 Press  (*Select*).

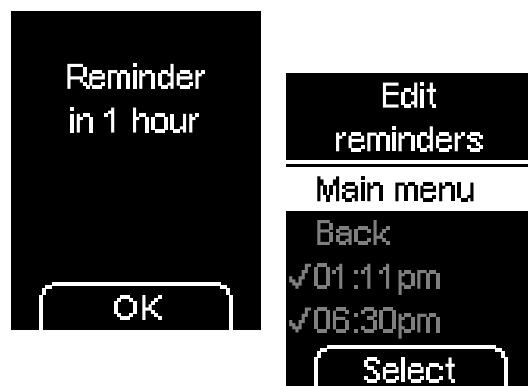

The meter displays that it will give you a reminder in 1 hour (or in 2 or 3 hours).









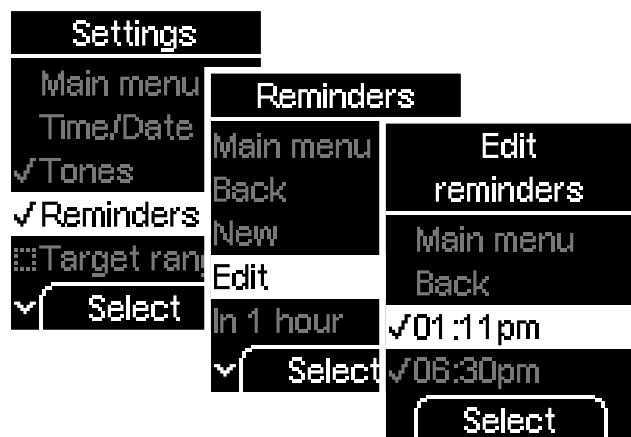
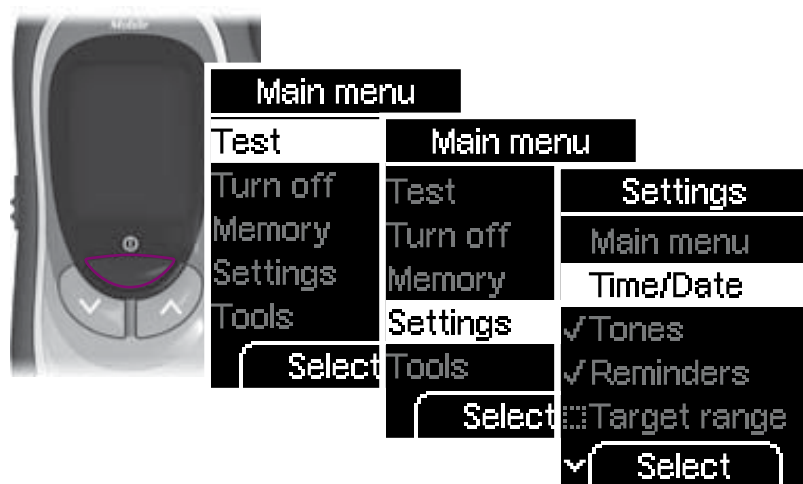

3 Press  (OK).

The meter returns to the *Edit reminders* menu.

The single reminder will be displayed in the list of reminders in the same way as any other reminder, i.e. the time will be displayed there and not "In 1 hour", for example.



Deleting a single reminder



- 1 Turn on the meter with ,
 - wait for the *Main menu*,
 - use   to select *Settings*,
 - press  to open *Settings*,
 - use   to select *Reminders*,
 - press  to open *Reminders*,
 - use   to select *Edit*,
 - press  to open *Edit*.

A list with the reminders that have already been set appears on the display.

A checkbox  indicates that the reminder is turned off, a tick  that it is turned on.

- 2 Use   to select the reminder time you wish to delete.
- 3 Press  (*Select*).

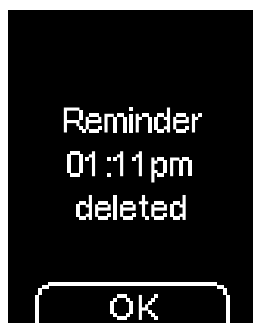
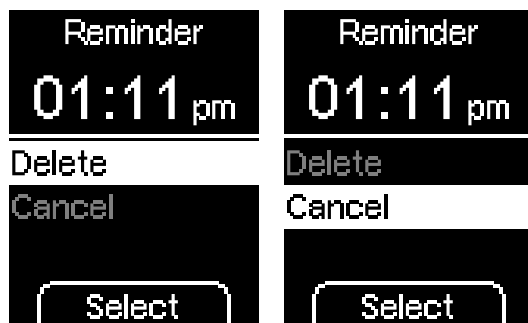

In the case of a single reminder, **only** the following options are displayed below the time:

- *Delete*, to delete this reminder
- *Cancel*, if you do not wish to delete this reminder

Unlike the daily reminders, you cannot turn reminders on or off or change their time.

4 Use   to select *Delete*.

5 Press  (*Select*).

The meter will then display the reminder time you just deleted.

6 Press  (*OK*).

The reminder time has now been deleted.

The meter returns to the *Edit reminders* menu or to the *Reminders* menu if you have deleted the last reminder.

4.6 Zielbereich einstellen

You can enter your personal target range for blood glucose values (default setting: Off). Results above or below this target range will be flagged with the symbol .

The target range gives the blood glucose values which should be achieved if the treatment is optimal. Discuss with your doctor what target range you should set.







You set the target range by entering the lower and upper limits. The lower limit can be set to between 2.8 and 5.5 mmol/l. The upper limit can be set to between 5.5 and 11.1 mmol/l. Both limits can be set in steps of 0.1 mmol/l.

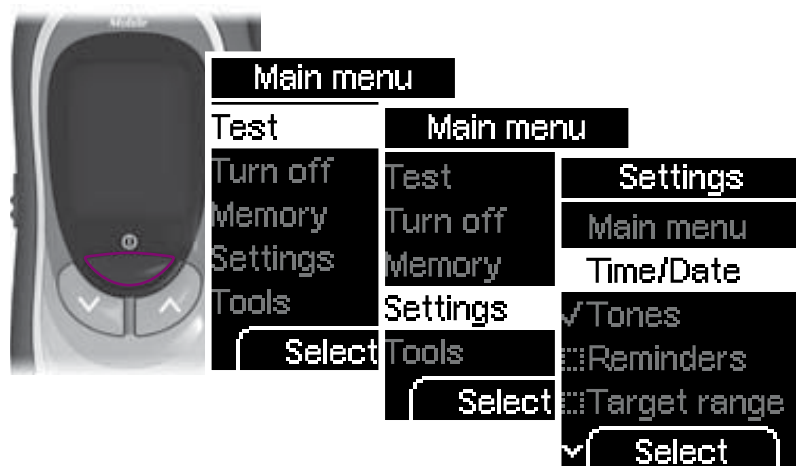



If you wish to use the lower limit of the target range as an indicator of a possible hypo, it is important to remember this: The indicator will only be reliable if the limit has been properly selected. We therefore strongly recommend that you talk to your healthcare professional before you set the limit. This function is no substitute for hypoglycaemia training by your doctor or diabetes team.

Setting a target range



- 1 Turn on the meter with ,
 - wait for the *Main menu*,
 - use   to select *Settings*,
 - press  to open *Settings*,
 - use   to select *Target range*,
 - press  to open *Target range*.

A checkbox  indicates that the target range is turned on, a tick  that it is turned off.

If you have not yet set a target range, the meter will take you directly to the display for entering the upper and lower limits. The two limits are indicated by dashes only.

If you decide you do not want to set a target range after all, press the  button (*Cancel*) to return to the Settings menu.



- Use to set the lower limit.

The first time you press a button, the default setting of 3.9 mmol/l will be entered.

- Continue (*Continue*).

The default setting of 7.8 mmol/l will be entered for the upper limit.

- Use to set the upper limit.

- Press (*OK*).





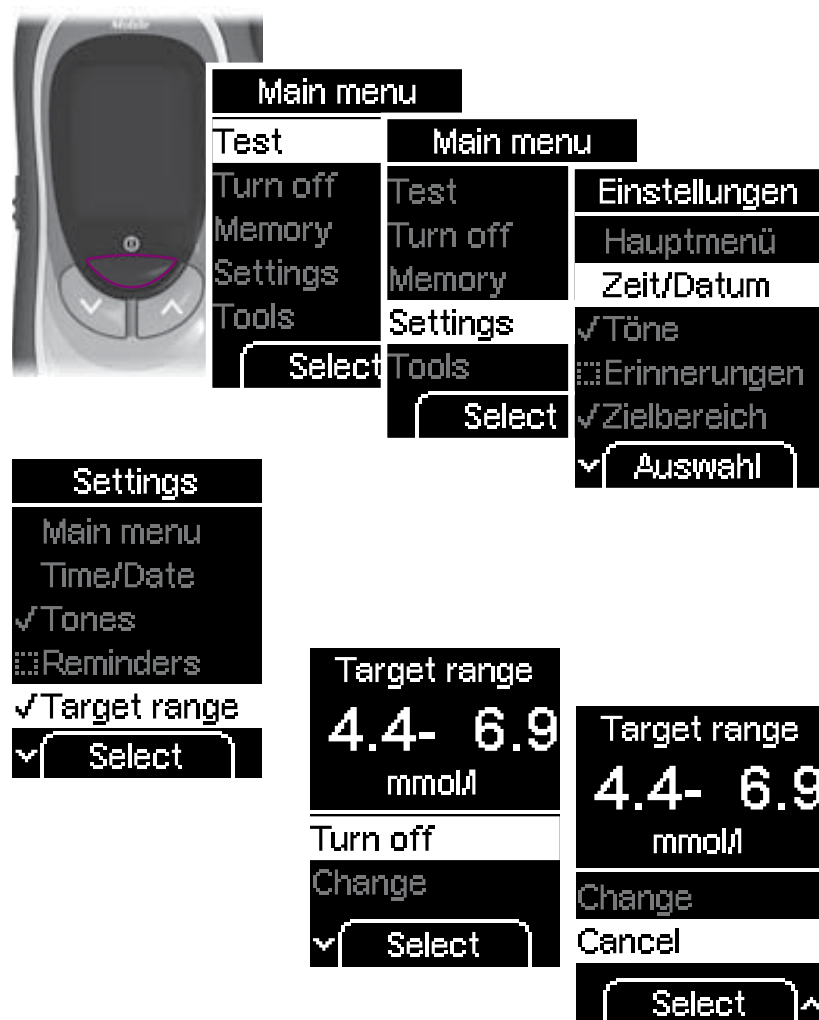

The meter will then display the target range you just set. It is also turned on.

- Press (*OK*).

The meter returns to the *Settings* menu.

Editing an existing target range (turn on/off, change)





- 1 Turn on the meter with ,
 - wait for the *Main menu*,
 - use   to select *Settings*,
 - press  to open *Settings*,
 - use   to select *Target range*,
 - press  to open *Target range*.

Once you have set a target range, the Target range menu will offer you the following options:

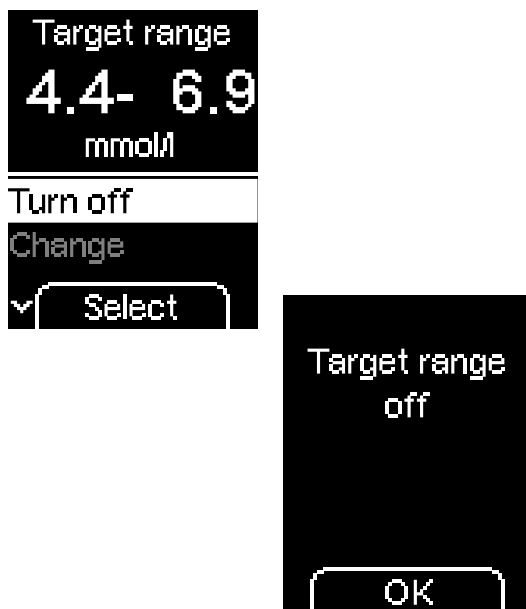
- *Turn off*, to turn off the target range (the upper and lower limits you have entered remain unchanged), or *Turn on* to turn on the target range.
- *Change*, to change the upper and lower limits of the target range
- *Cancel*, if you do not wish to edit the target range



Turning the target range on or off

- 1 Use   to select *Turn off (Turn on)*.
- 2 Press  (*Select*).

The meter displays that the target range is now turned off (turned on).

- 3 Press  (*OK*).

The meter returns to the *Settings* menu.

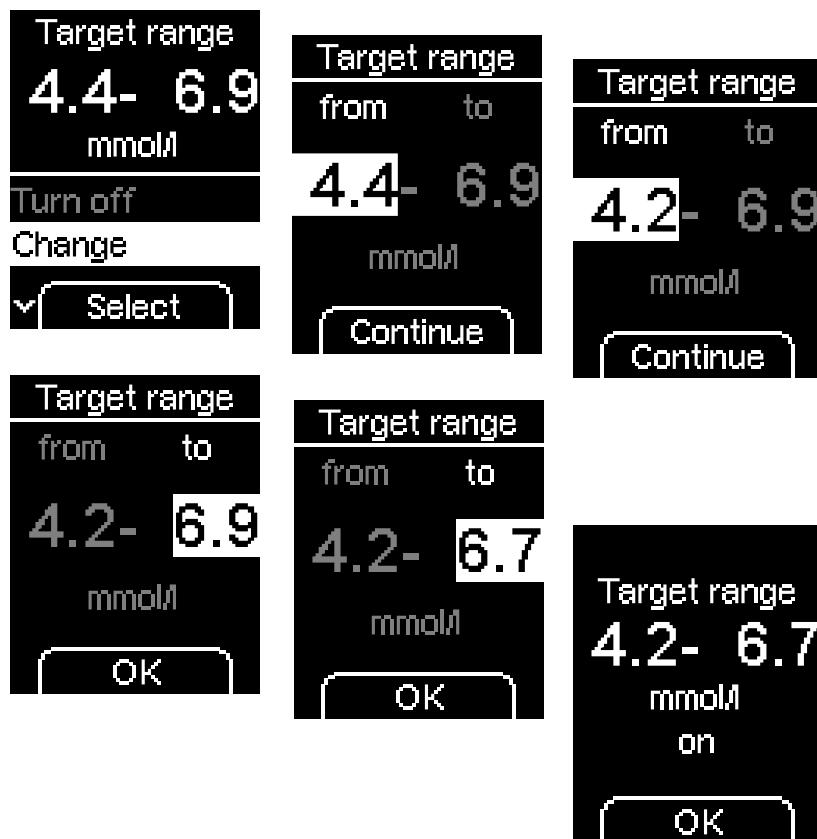

Changing a target range

- 1 Use to select *Change*.
- 2 Press (*Select*).
- 3 Set the new target range (see “Setting a target range” for how to do this).

The meter will then display the target range you just changed.

- 4 Press (*OK*).

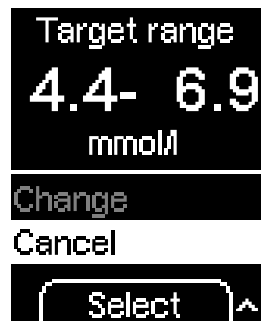

The target range has now been changed and is also turned on.

The meter returns to the *Settings* menu.



Cancel – Not editing the target range

If you do not want to change the target range after all, you can cancel the editing procedure as follows.





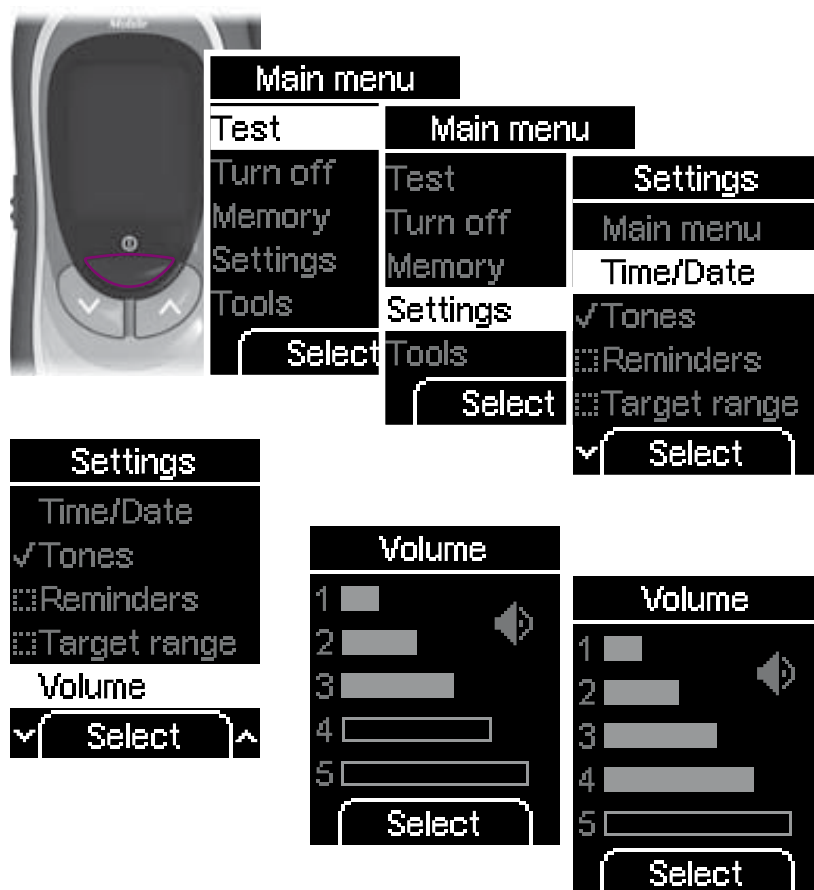

- 1 Use   to select *Cancel*.
- 2 Press  (*Select*).

The meter returns to the *Settings* menu without changing the target range.

4.7 Setting the volume



You can set the volume for the beeper to one of 5 different levels.

- 1 Turn on the meter with ,
 → wait for the *Main menu*,
 → use   to select *Settings*,
 → press  to open *Settings*,
 → use   to select *Volume*,
 → press  to open *Volume*.

The more bars are filled in on the display, the louder the volume. The default setting is 3.

- 2 Use   to set the volume.

Each time you press the button, a beep sounds in the new volume selected.

- 3 Press  (*Select*).

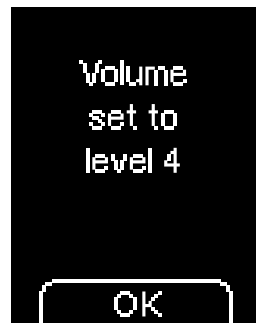

The meter will then display the volume level you just set.





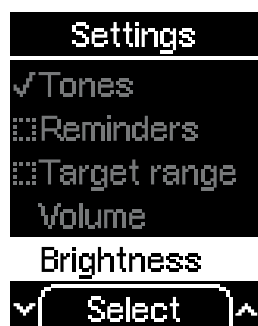
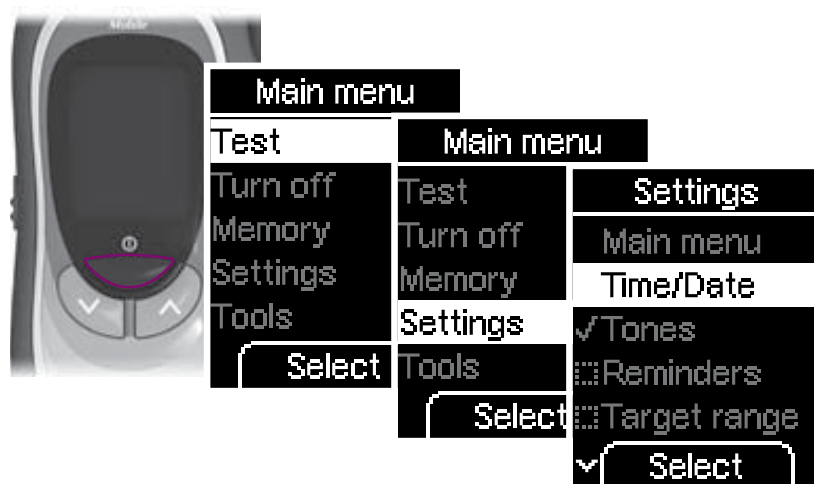

4 Press  (OK).

The meter returns to the *Settings* menu.



4.8 Setting the brightness



You can set the brightness of the texts and symbols appearing on the display to one of 3 different levels.

- 1 Turn on the meter with ,
 - wait for the *Main menu*,
 - use   to select *Settings*,
 - press  to open *Settings*,
 - use   to select *Brightness*,
 - press  to open *Brightness*.

The more bars are filled in on the display, the brighter the display. The default setting is 2.

- 2 Use   to set the desired brightness.

The brightness of the display will be adjusted to the level you have selected.

- 3 Press  (*Select*).



The meter will then display brightness level you just set.

4 Press  (OK).

The meter returns to the *Settings* menu.





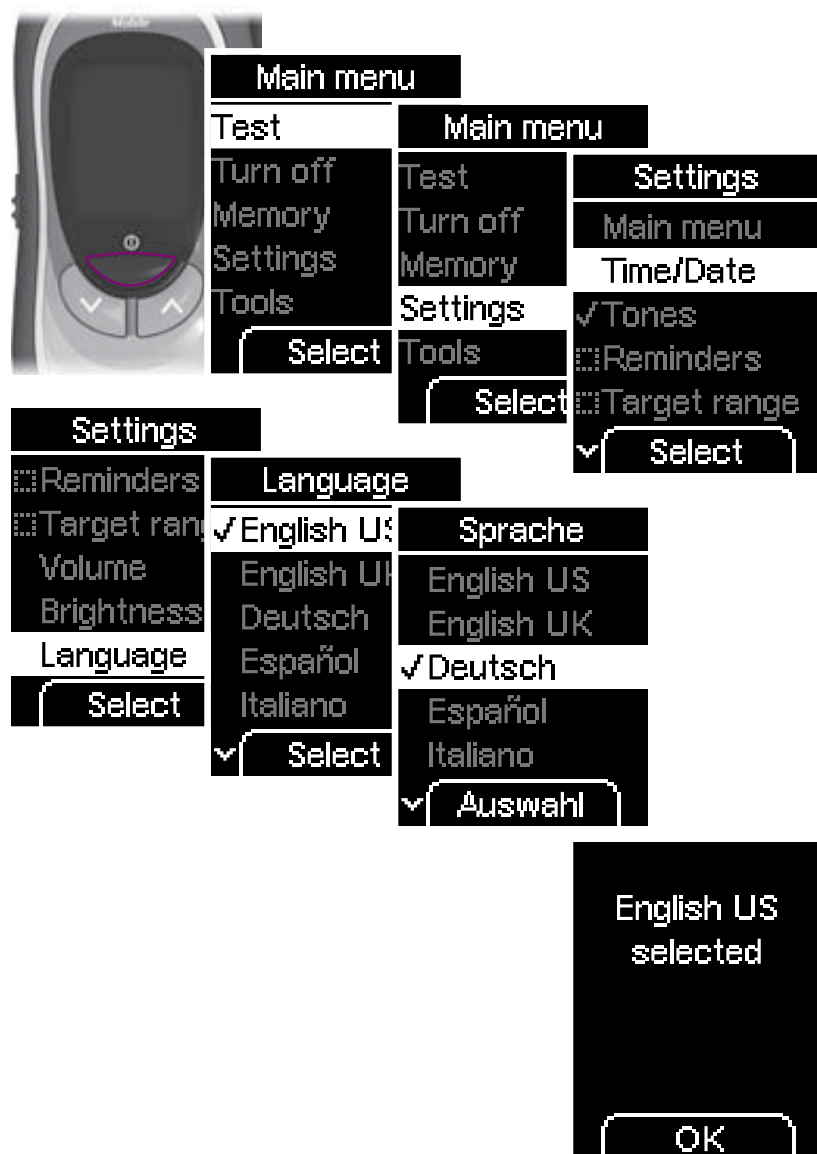

4.9 Setting the language

You can choose from a total of 15 languages for the texts appearing on the display. You will already have set the language when you turned on the meter for the first time.



If you want to change this selection at a later date, you can set any of the following languages:

- English US
- English UK
- Deutsch
- Español
- Italiano
- Français
- Dansk
- Svenska
- ニホンゴ
- Türkçe
- Português
- Ελληνικά
- Norsk
- Suomi
- Nederlands



- 1 Turn on the meter with ,
 → wait for the *Main menu*,
 → use   to select *Settings*,
 → press  to open *Settings*,
 → use   to select *Language*,
 → press  to open *Language*.

The currently set language is highlighted.

- 2 Use   to select the desired language.
- 3 Press .

The meter will then display the language you just selected.

- 4 Press  (*OK*).

The meter returns to the *Settings* menu.

Correcting a wrongly set language

If you have set the wrong language by mistake, you may not be able to read the menus any more. You can still change the language with the help of the following instructions.

- 1 Turn on the meter with .

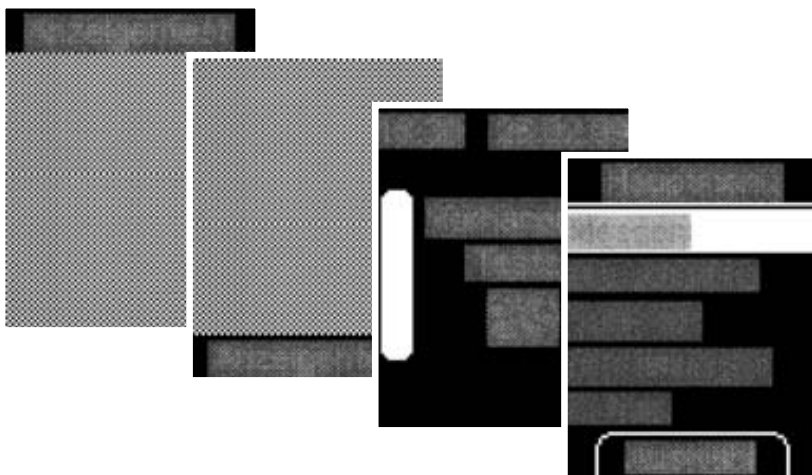

- 2 Wait until the display sequence shown above has been displayed and the display does not change any more.

The last (right-hand) display is the main menu, but with the text displayed in the wrongly set language.

- 3 Press  3 times.

“Settings” is now highlighted.



- 4 Press .

- 5 Press  6 times.

“Language” (the last item) is now highlighted.

- 6 Press .

The “Language” menu is now open.

- 7 Use   to select the desired language.

- 8 Press .

The meter will then display the language you just selected.

- 9 Press  (OK).

The meter returns to the “Settings” menu.

5 Using the meter as an electronic notebook

The meter has a 500-value memory for saving results together with the time and date. You do not need to save the results manually. The meter automatically saves all the results.

In addition to the result, the time and the date, your meter also saves all other information that is relevant to the test. This includes all symbols displayed with the result after a test (except the battery symbol) and the flags you added to the results.

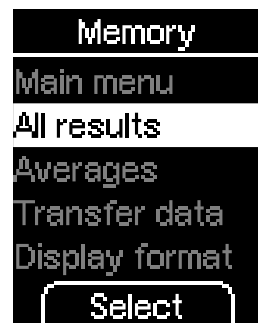

The following options are available in the *Memory* menu:

- *Main menu*: takes you to the Main menu
- *All results*: display all the saved results
- *Averages*: view the averages for the last 7, 14 or 30 days
- *Transfer data*: transfer the saved results (to a computer, PDA (handheld computer) or special analysis systems)
- *Display format*: select how the saved results are to be displayed

5.1 Viewing saved results

There are two different ways of viewing all saved results:

- via the *Memory* menu
- using the  button

The  button takes you directly to the saved results. In this case, the options offered in the *Memory* menu are not available. If you want to use all the options in the *Memory* menu, you must open it from the Main menu.

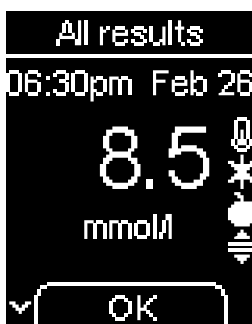

Display format *Single value*

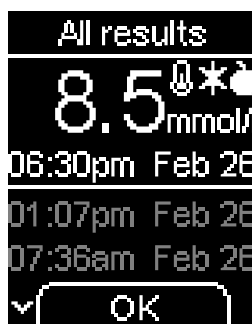





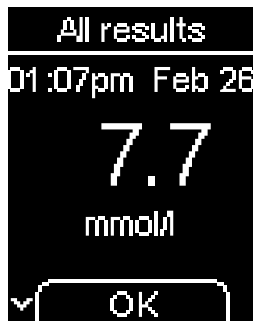
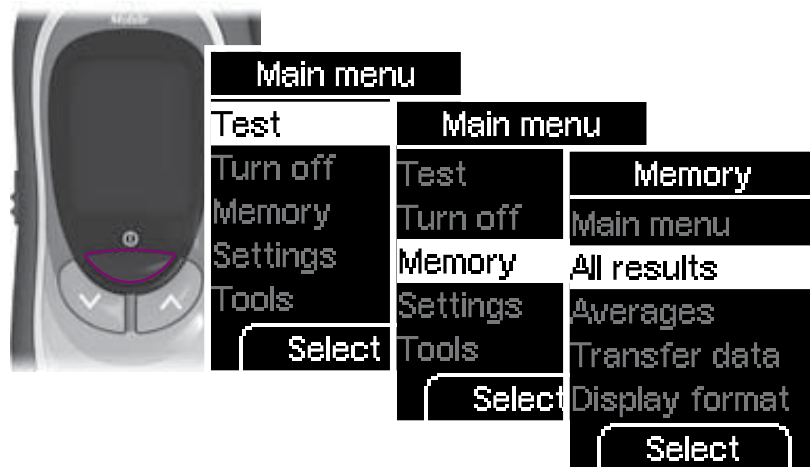
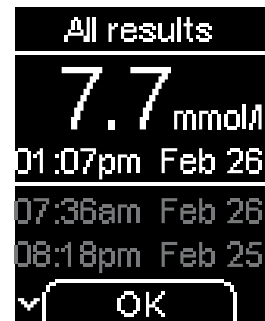

Display format *List*

There are two display formats available for the saved results. *Single value* and *List*. The default setting is *Single value*. The procedure for changing the display format is described in Chapter 6.4.

Symbols saved together with the result appear to the right of the result. In the display format *Single value*, 4 symbols can be displayed, in the display format *List* only 3. If the result is flagged with 4 symbols, the symbol  (result outside the target range) is not displayed in the display format *List*.

Via the *Memory* menuDisplay format *Single value*Display format *List*

- 1 Turn on the meter with ,
 - wait for the *Main menu*,
 - use   to select *Memory*,
 - press  to open *Memory*,
 - use   to select *All results*,
 - press  to open *All results*.

The last saved result will be displayed, as either *Single value* or *List*, depending which display format has been set.

-  If no results have been saved, X will be displayed instead of the result and dashes instead of the time and date.

Single value

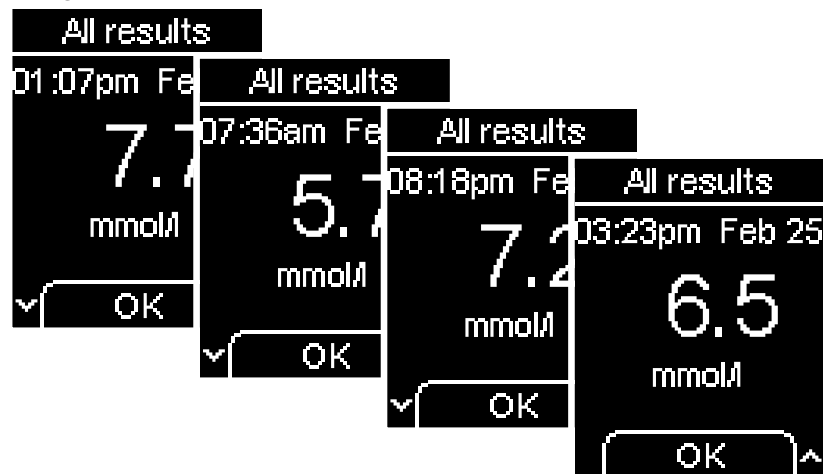

List

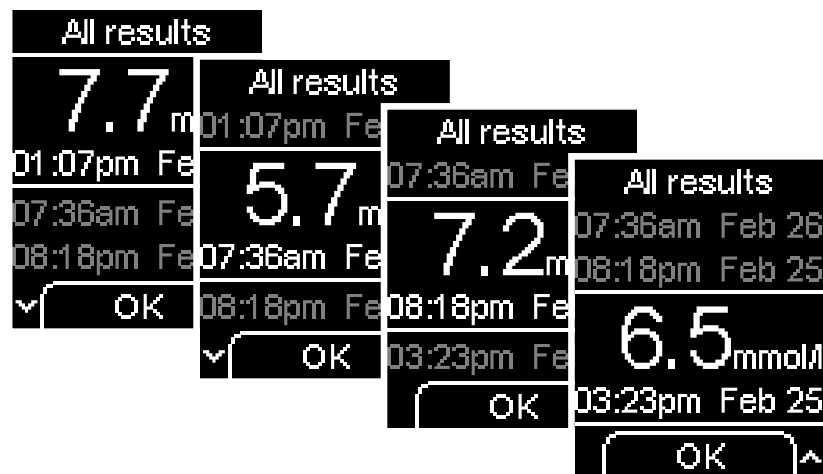

Viewing older results

1 Press  to go to the next older result.

If you then want to return to the more recent results:

2 Press  to go to the next more recent result.

If you hold the buttons down, the results will be displayed in rapid succession, first slowly, then more quickly. The display stops when the oldest and the most recent (last) results are reached.

3 Press  (OK).

The meter returns to the *Memory* menu.

Via the  button (down)



With the meter off:

- 1 Press and hold  until the meter turns on (longer than 2 seconds).



Display format *Single value*

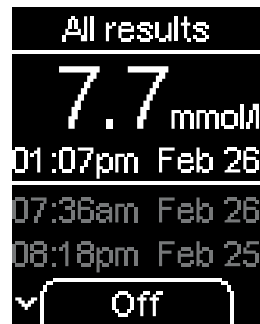

Display format *List*

The last saved result will be displayed, as either Single value or List, depending which display format has been set.

Single value

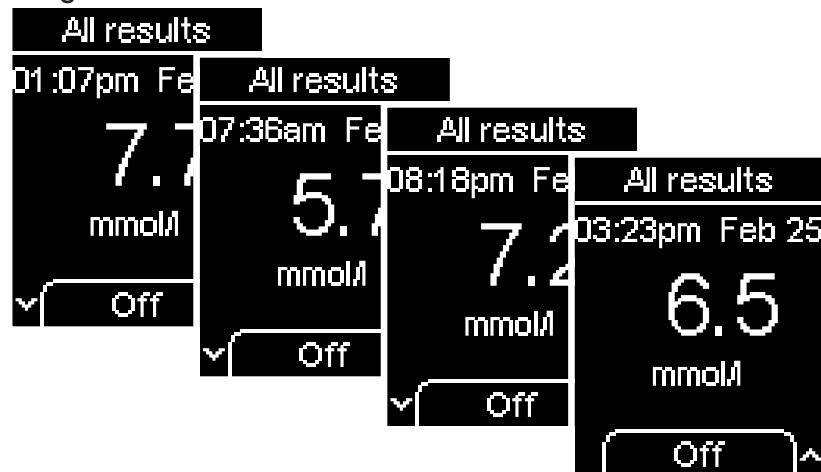

List

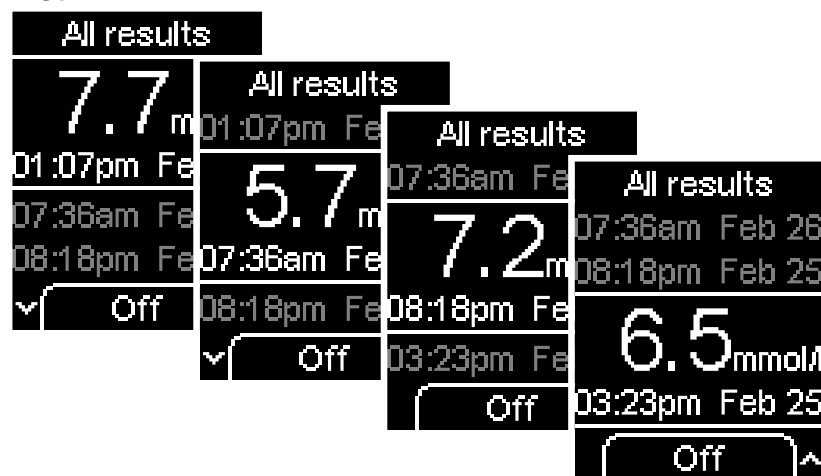

Viewing older results

1 Press  to go to the next older result.

If you then want to return to the more recent results:

2 Press  to go to the next more recent result.

If you hold the buttons down, the results will be displayed in rapid succession, first slowly, then more quickly. The display stops when the oldest and the most recent (last) results are reached.

3 Press  (Off) to turn off the meter.

5.2 Viewing averages

The meter can calculate averages from the saved results.



You can choose which results are used for calculation of the averages.

- all results
- only results flagged *Before meal*
- only results flagged *After meal*





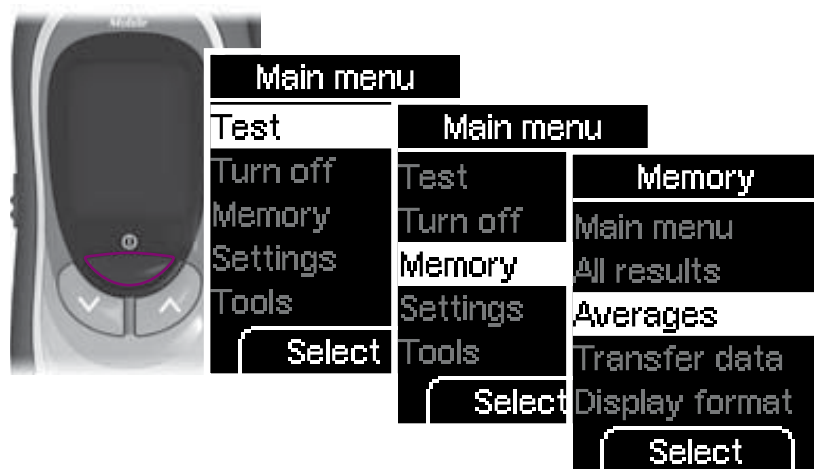

When you have made this selection, you can choose the period of time in which the results were obtained.

- the last 7 days
- the last 14 days
- the last 30 days

The average will be calculated from all results corresponding to your choice. However, the following results will not be included in the calculation:

- control tests (flagged with )
- results you have flagged with * (*General*),
- results displayed as **LO** or **HI**,
- results of tests performed outside the permitted temperature range of +10 to +40 °C (flagged with )



- 1 Turn on the meter with ,
→ wait for the *Main menu*,
→ use   to select *Memory*,
→ press  to open *Memory*,
→ use   to select *Averages*,
→ press  to open *Averages*.

The following options are available in the *Averages* menu:

- *Main menu*: takes you to the Main menu
- *Back*: takes you to the *Memory* menu
- *All results*: calculate the average from all results
- *Before meal*: calculate the averages from the results flagged *Before meal*
- *After meal*: calculate the averages from the results flagged *After meal*

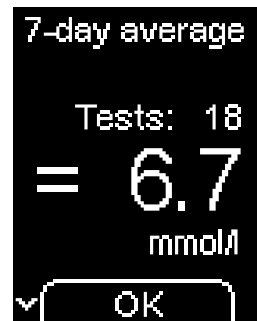





- 2 Use to select *All results*, *Before meal* or *After meal*.
- 3 Press (*Select*).
- 4 Use to choose the period in which the results were obtained: 7, 14 or 30 days.

Selecting the time period only determines which average will be displayed first. You can later switch directly from one time period to the others.

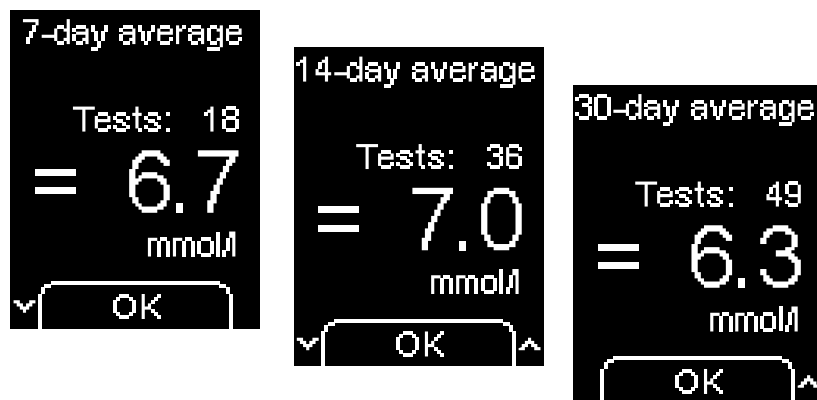
- 5 Press (*Select*).

The selected average is displayed, together with the number of results (called tests) from which the average was calculated.



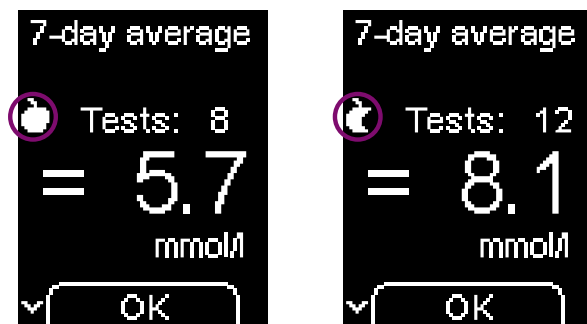

- 6 Press  to switch from the 7-day average to the 14-day average and then to the 30-day average.
- 7 Press  to switch from the 30-day average back to the 14-day average and then to the 7-day average.
- 8 Press  (OK).

The meter returns to the *Averages* menu.



Averages Before meal are marked with the symbol .

Averages After meal are marked with the symbol .

-  The meter calculates the average for a time period even if the saved results cover a shorter period. Example: tests were only performed in the last 5 days. In this case, the averages for all three periods (7, 14 and 30 days) are calculated from the results of the last 5 days.
-  If no average can be calculated, XX is displayed instead of a value and the number of results (tests) is given as zero. This is the case if either no results or only results which are not used for calculation of averages were saved in the specified period.

-  In the event that you changed the date or time, then performed a test and afterwards re-set the date or time, the meter only calculates the average from the results which the meter saved in uninterrupted chronological order. If the chronological order was interrupted, the earlier results are ignored. If you have not performed any tests since you made the change, XX is displayed instead of a value and the number of results (tests) is given as zero.

5.3 Transferring results

The meter has an inbuilt IrDA (Infrared Data Association) standard infrared window permitting wireless transfer of the results to a suitably equipped computer, PDA (handheld computer) or to special analysis systems.

The infrared window is located in the battery compartment cover of the meter.



Infrared window

There are two ways of transferring the results:

- with special products from Roche Diagnostics which can also analyse results
- in the form of a table which you can then process with a spreadsheet program, for example.

Roche Diagnostics offers a variety of special hardware and software products for analysis which extend the integrated notebook functions of your meter. These products enable you and your doctor to manage your data more effectively and, through their graph and table views, make it easier for your to understand your results.

Depending on the type of analysis you intend to perform, you will require a special software product and/or special hardware products. For further information, please contact your customer support and service centre.

If you already have a hardware or software product from Roche Diagnostics to enable you to transfer and analyse results, it may not recognize more recent meters, so the results will not be transferred. You may need a more recent software version for your hardware or software product. In this case, contact your customer support and service centre.

The results remain in the meter's memory after transfer.

You cannot perform a test while results are being transferred.

There are two ways of opening the *Transfer data* menu:

- using the  and  buttons
- via the *Memory* menu

In the *Transfer data* menu, you can choose how you wish to transfer the results.

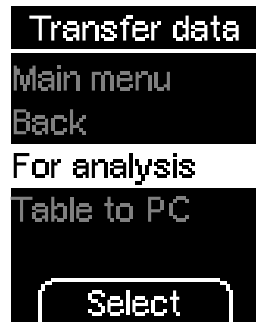

The following options are available in the Transfer data menu:

- *Main menu*: takes you to the *Main menu* (only if you opened the menu from the *Memory* menu)
- *Back*: takes you to the *Memory* menu (only if you opened the menu from the *Memory* menu)
- *For analysis*: transfer the results with hardware or software products from Roche Diagnostics
- *Table to PC*: transfer the results to a PC in the form of a table

Starting the transfer using the  and  buttons



With the meter off:



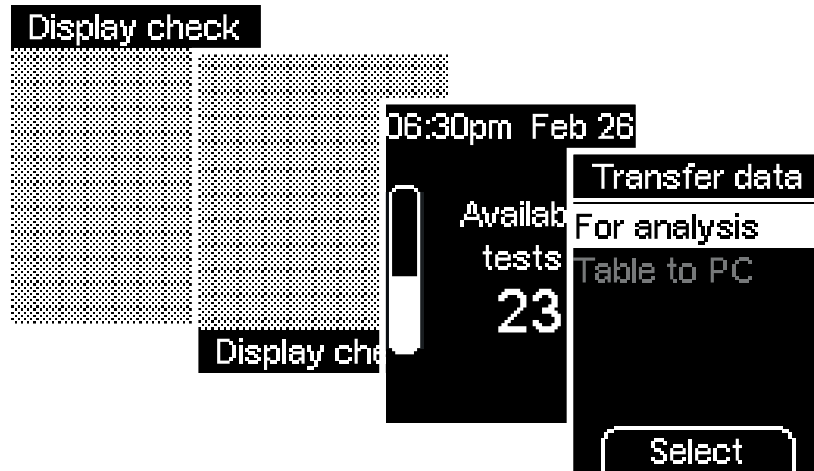



Press and hold the  and  buttons simultaneously until the meter turns on (longer than 2 seconds).

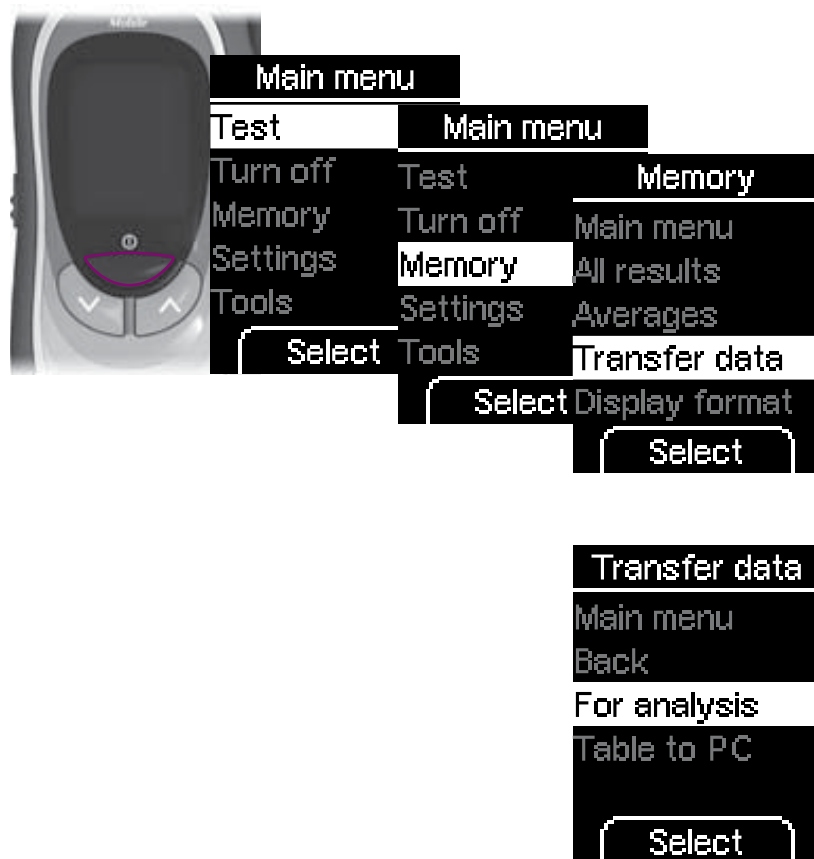

After the display check and the number of available tests, the *Transfer data* menu is displayed.

Starting the transfer via the *Memory* menu



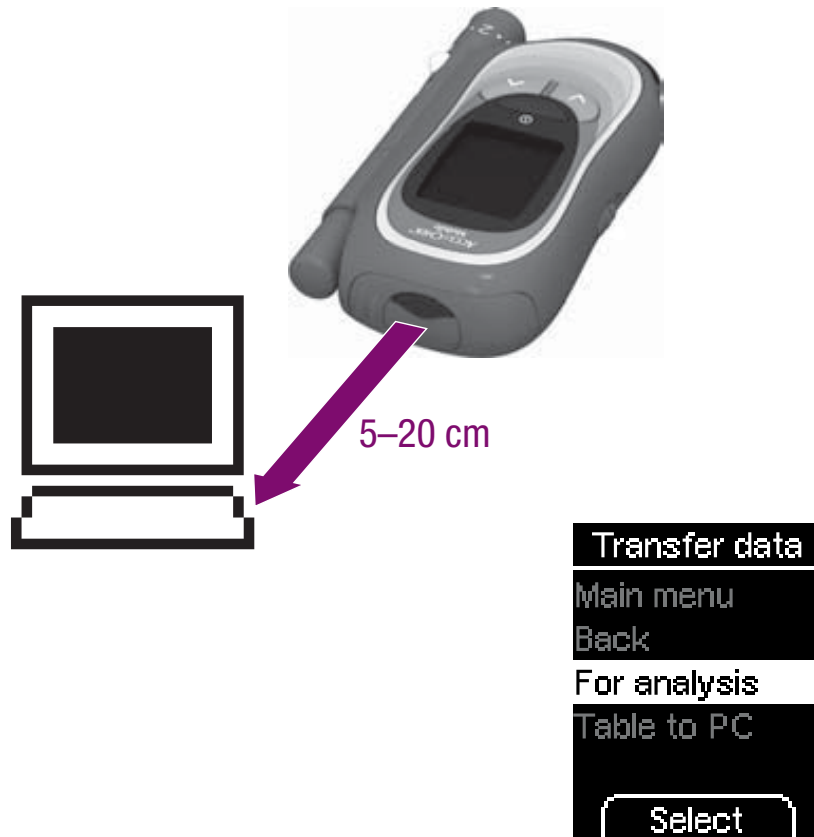

- Turn on the meter with ,
- wait for *Main menu*,
- use   to select *Memory*,
- press  to open *Memory*,
- use   to select *Transfer data*,
- press  to open *Transfer data*.

Transferring data for further analysis





- 1 Please read the instructions for use supplied with the software or hardware you are using. These will include instructions on how to transfer data.
- 2 Make the receiving end (software product or hardware) ready to transfer the results.
- 3 Position the meter 5–20 cm away from the infrared window of the receiving end. Point the two infrared windows towards one another.

- 4 In the *Transfer data* menu: use   to select *For analysis*.
- 5 Press  (*Select*) to start transferring the results.

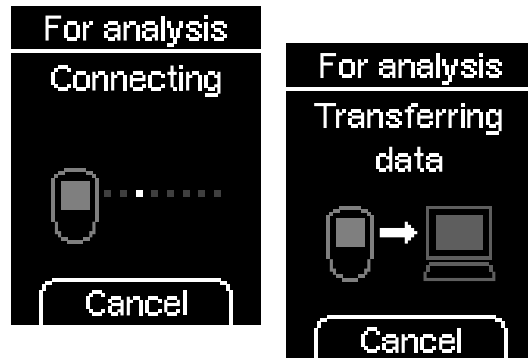
- 6 If necessary, start the transfer of the results at the receiving end (software product or hardware).



During the transfer, you will be informed of the progress on the display.

If you do not want to transfer the results after all, you can abort the transfer using the  button (*Cancel*). The meter returns to the Memory menu (if you came from the Memory menu) or turns off (if you turned on the meter using the   buttons).



When the transfer of the results is finished, the meter turns off automatically about 2 seconds later.

Transferring results as table

The meter can transfer the results to a computer without any special hardware or software. The only prerequisite is that the computer has an infrared window according to the IrDA standard (Infrared Data Association).

The results are transferred as CSV file. CSV in this case stands for *Comma Separated Values* as the individual results are separated by semicolons.

CSV files can be opened with a text editor or spreadsheet program, for example.

Where you find the CSV file on your computer depends on the settings in your operating system for wireless transmission of files via the infrared window.

The CSV file always contains all the results saved in your meter. Results already transferred at an earlier date are transferred again.

The CSV file contains the following information:

- *Serial number*: the serial number of the meter
- *Datum Download (DD.MM.YYYY), Download Time (hh:mm)*: the date and time when the meter transferred the results to the computer.
- Date (DD.MM.YYYY), time (hh:mm), result and unit of the results saved in the meter.
- *Flags* added to the results, indicated by an “X”.

In the CSV file, the date is always displayed in the format DD.MM.YYYY and the time always in the 24-hour format (hh:mm). The time format set in the meter has no influence on the format of the date and time in the CSV file.

CSV file opened in a text editor



```
Header data: Serial number;Download Date;Download Time
123456789;10.05.2009;09:18
Date;Time;Result;Unit;Temperature warning;Beyond target range;General;Before meal;After meal;Control test
10.05.2009;08:21;6.5;mmol/l; ; ; ; ;
09.05.2009;18:05;7.1;mmol/l; ; ; ; ;
09.05.2009;12:37;7.5;mmol/l; ;X; ; ;
09.05.2009;08:16;6.2;mmol/l; ; ;X; ;
08.05.2009;18:39;3.2;mmol/l; ; ; ; ;X
```

CSV file opened in a spreadsheet program (example)

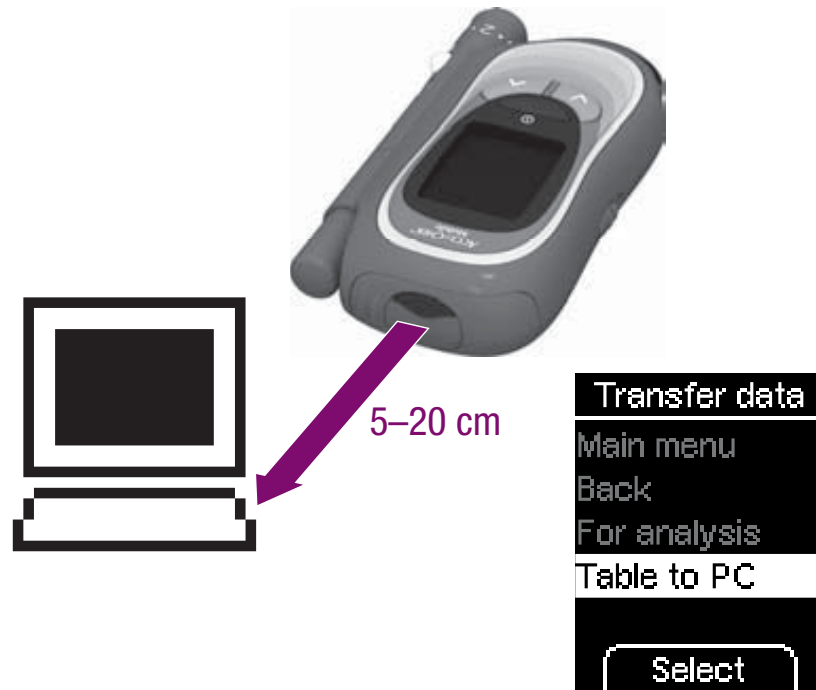
Header data: Serial number				Download Date	Download Time				
123456789				10.05.2009	09:18				
Date	Time	Result	Unit	Temperature warning	Beyond target range	General	Before meal	After meal	Control test
10.05.2009	08:21	6.5	mmol/l						
09.05.2009	18:05	7.2	mmol/)						
09.05.2009	12:37	7.5	mmol/l		X				
09.05.2009	08:16	6.2	mmol/l				X		
08.05.2009	18:39	3.2	mmol/l						X



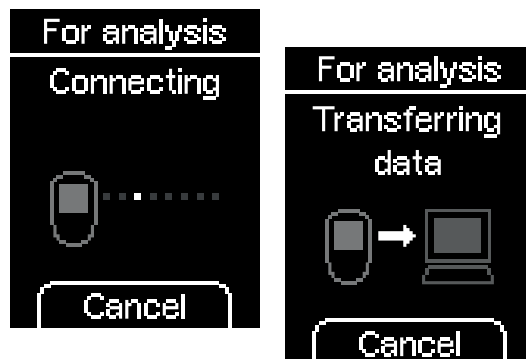

- 1 Turn on the computer.
- 2 Position the meter 5–20 cm away from the infrared window of the computer. Point the two infrared windows towards one another.

- 3 In the Transfer data menu: Use   to select *Table to PC*.
- 4 Press the  (*Select*) to start transferring the results.



During the transfer, you will be informed of the progress on the display.

If you do not want to transfer the results after all, you can abort the transfer using the  button (*Cancel*). The meter returns to the *Memory* menu (if you came from the *Memory* menu) or turns off (if you turned on the meter using the   buttons).



When the transfer of the results is finished, the meter turns off automatically about 2 seconds later.

If the transfer is unsuccessful

If the results are not transferred, the meter turns off automatically after about 60 seconds.

Possible reasons for unsuccessful transfer are:

- A transfer error occurred.
Start the transfer of the results again.
- The infrared windows are too far apart or not properly facing each other.
Reduce the distance between the two infrared windows to 5–20 cm and position them so they are pointing towards one another. Start the transfer of the results again.
- Another device with an infrared source turned on or a strong light source is too close to one of the two infrared windows.
Remove the device or light source and start the transfer of the results again.
- There is some object, for example, blocking communication between the two infrared windows.
Remove the object and start the transfer of the results again.
- An error occurred at the receiving end.
Please read the relevant instructions for use.

5.4 Setting the display format for viewing saved results

There are two different formats available for displaying the saved results (*Memory* menu– *All results*): *Single value* and *List*.

Display format *Single value*

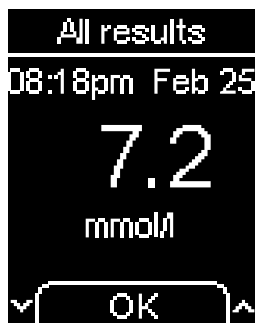





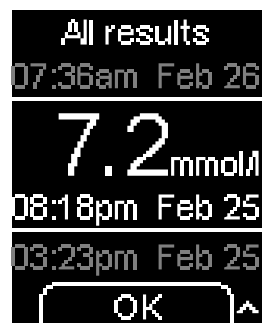

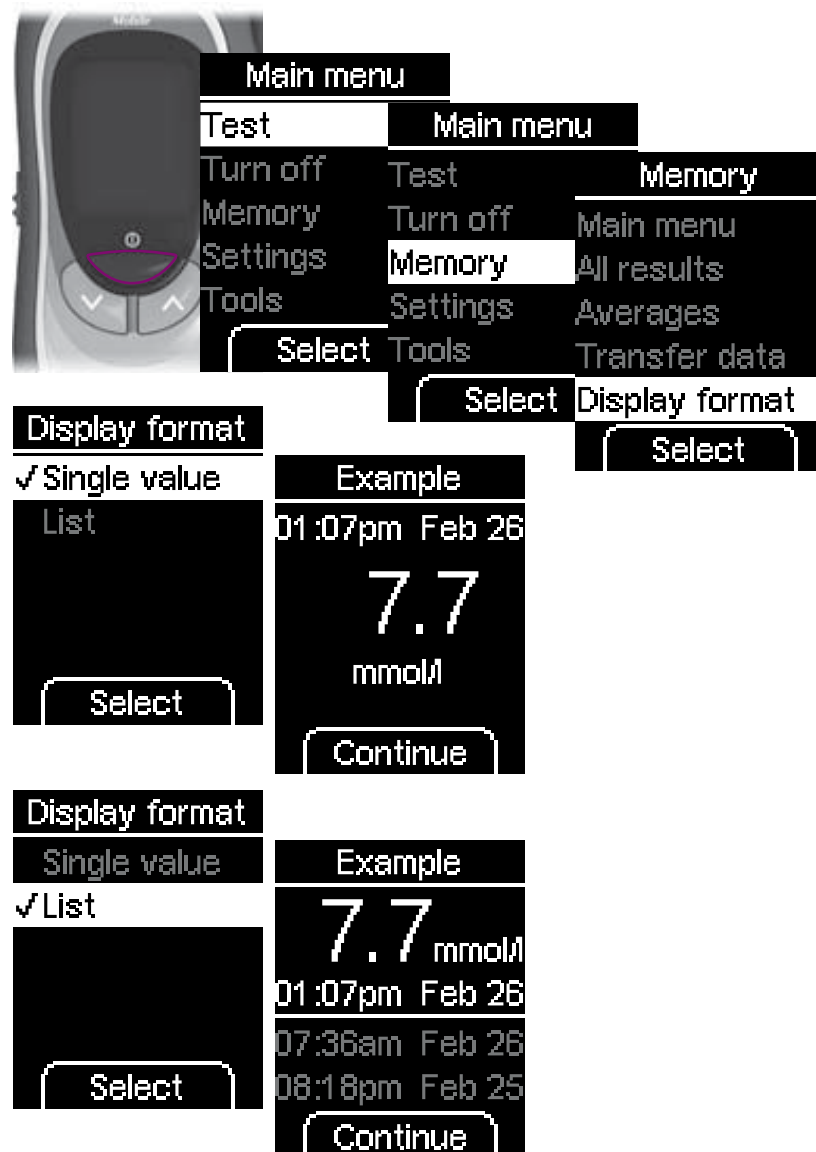

Display format *Single value* (default setting):
In this format, just one result is displayed on the display. The time and date on which the result was obtained are displayed above the result (in this case 7.2 mmol/l).



Display format *List*



Display format *List*:
In this format, three results are displayed on the display. The selected value is between the two horizontal lines. This is the only actual result displayed. The time and date are displayed below the result. For the other two results, only the time and date are displayed. The more recent results are above the selected result, the older results below.



- 1 Turn on the meter with ,
 → wait for the Main menu,
 → use   to select *Memory*,
 → press  to open *Memory*,
 → use   to select *Display format*,
 → press  to open *Display format*.

- 2 Use   to select the desired display format.
- 3 Press  (*Select*).

An example of the display format you selected is displayed.

- 4 Press the  (*Continue*).

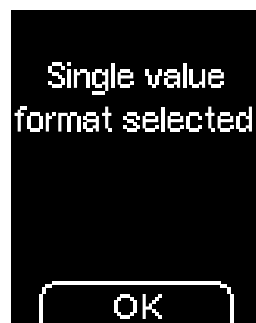

or



The meter will then display the display format you just set.

5 Press  (OK).

The meter returns to the *Memory* menu.

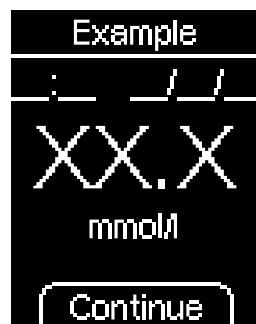

or



If no results have been saved, X will be displayed instead of the result and dashes instead of the time and date.

6 Acoustic mode

The procedure for turning on the acoustic mode is described in Chapter 4.4.

When the acoustic mode is turned on, the meter guides you through the blood glucose test using beep tones and announces the result as a series of beeps. The meter beeps additionally when the batteries are almost empty, the test cassette is empty or an error message is displayed. Saved results are not announced acoustically.

An intimate knowledge of how results are announced as beeps and how to distinguish results from other beeps is crucial to reliably recognizing the result.

The sections below explain the beep tones in detail. In addition, training software (the BeepLearn program) to help you interpret results announced in the form of beeps is available on CD from your customer support and service centre.





Visually impaired people should only use the acoustic mode if they have familiarized themselves fully with the acoustic mode with the assistance of a sighted person and have demonstrated that they are able to

understand results correctly without exception using the acoustic mode. The acoustic mode should always be used with great care. Otherwise there is a risk that the results will be misinterpreted by the person performing the test. An incorrect insulin dose resulting from a misinterpreted result can cause considerable health damage and can even be fatal. Especially if unexpected and abnormal blood glucose values are obtained using the acoustic mode, the result must be checked by repeating the test together with a sighted person.

Visually impaired people should not test their blood glucose without assistance from a sighted person.

The meter must be regularly checked by a sighted person for outwardly visible contamination.

There are two types of beep tones, differing in pitch. Warnings have a higher pitch (Tone 2, represented below as ) than the other beep tones (Tone 1, represented below as ). The following table shows which tone sounds for which event.

Tone 1: 

Turning on	Chapter 6.1
Prompt to apply blood	Chapter 6.2
Start of test	Chapter 6.2
Announcement of the result	Chapter 6.3





Tone 2:  (warning)

Signal that results are about to be announced	Chapter 6.3
Announcement of an error message	Chapter 6.2, 6.4
Notification that the batteries are almost empty	Chapter 6.4
Notification that the cassette is empty	Chapter 6.4

6.1 Beep tone when turning on

When the acoustic mode is turned on, you hear a beep (—) when you turn the meter on.

This is irrespective of how you turn on the meter:

- by opening the tip cover to perform a test (see Chapter 3.2)
- by opening the tip cover to perform a test (see Chapter 3.2)  button (see Chapter 2.2).
- using the  button to view saved results (see Chapter 5.1)
- using the  and  buttons to transfer data (see Chapter 5.3)

6.2 Beep tones during a test

After the power-on beep, you will hear the following while you test

- a beep tone when you can apply blood or control solution,
- a beep tone when the test starts,
- the result which is composed of different beep tones (see Chapter 6.3),
- several beep tones if the meter displays an error message (see Chapter 6.4).

6.3 Announcement of the result after a test

In the acoustic mode, whenever the meter displays a result following a blood glucose test, it also announces the result as a series of beeps. The result is not treated as an entity, but is broken down into individual digits.

Examples:



- The result 7.6 mmol/l is announced as 0 – 7 – decimal point – 6.

Each digit is represented by the corresponding number of beeps, e.g. 4 beeps for the number 4 (— — — —). Zero is represented by a long beep (————).

Results which are lower than 0.6 mmol/l and are displayed as **LO** are announced acoustically as 0 – 0 – decimal point – 0.

Results which are higher than 33.3 mmol/l and are displayed as **HI** are announced acoustically as 9 – 9 – decimal point – 9.

The result is announced three times in succession. Each announcement is preceded by 2 short beeps (– –). Altogether, therefore, you hear: – – result – – result – – result.

Symbols, such as  or , which are displayed together with the result are not announced acoustically.

If you turn off the meter using the On/Off  button while the result is being announced acoustically, the announcement will be interrupted and 2 short beeps will sound four times in succession (– – – – – – – –).

6.4 Announcements of warnings and error messages

When the batteries will soon be empty or the last test area on the cassette has been used, the meter issues an acoustic warning. This consists of two short beeps sounded three times in succession (— — — — —).

The warning is given at different times.

- Batteries almost empty:
The acoustic warning sounds after you have turned the meter on, together with the corresponding message on the display (see Chapter 14).
- You have used the last test area on the test cassette:
The acoustic warning sounds when the number of available tests is displayed as zero on turning off the meter.

If error messages appear on the display (see Chapter 16.4), these are announced by two short beeps sounded four times in succession (— — — — —). This sequence is sounded only once and is not repeated. The same sequence of beeps is sounded for all error messages, i.e. they are not differentiated acoustically.

7 Checking the meter

You can check whether the meter delivers correct results. To perform this control test, a glucose control solution is applied to the test area instead of blood. At the end of the test, the meter automatically checks whether the result obtained with glucose control solution is correct and informs you of the result.

Always perform a control test using Accu-Chek Mobile control solutions

- after you have inserted a new test cassette,
- after you have changed the batteries,
- after you have cleaned the cassette and the inside of the meter,
- if you are in doubt about a result.

Please ask your customer support and service centre where you can obtain the control solutions.

Different control solutions are sold in different countries. The control solutions have different colored labels (red, blue or white). At the end of the control test, the meter asks you to enter the color of the label on the control solution you have used (see Chapter 7.2). The meter offers you a choice of all three colors, even if you only have one or two control solution(s) to choose from.



Store the control solution out of the reach of children. There is a danger of choking if the vial or the cap are swallowed.



The control solution must not be drunk. It contains substances which could be harmful to health.



Visually impaired people should not carry out a control test without assistance from a sighted person.

7.1 Preparing for a control test



For a control test you need:

- the meter with inserted test cassette,
- an unopened applicator vial of Accu-Chek Mobile control solution; the solution in each applicator vial is for one application only.

A control test in its main steps is the same as a normal test except that you apply control solution to the test area instead of blood.

Please read the package insert provided with the control solutions.

7.2 Performing a control test



Start as for a blood glucose test: Either open the tip cover or select Test in the *Main menu*.

The following description assumes that you start the test by opening the tip cover.

- 1 Place your finger on the corrugated area on the tip cover and push in the direction of the arrow as far as it will go.

After overcoming a slight resistance, the tip cover clicks into place.



Be careful not to touch the tape when doing this as this could damage it.

If the meter was turned off, it now turns on.

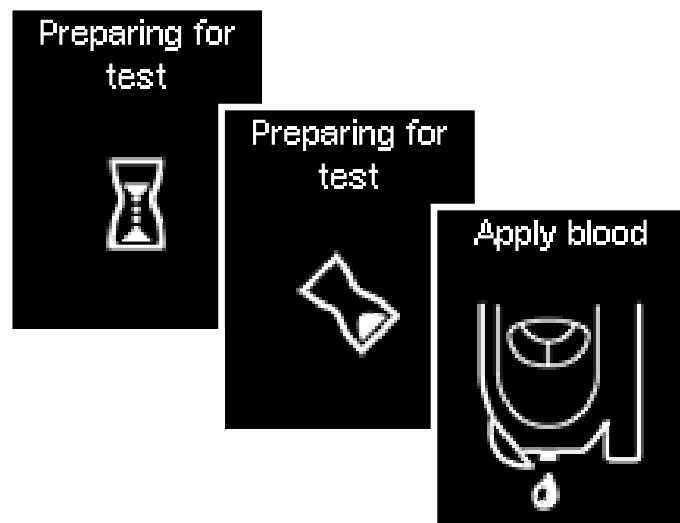
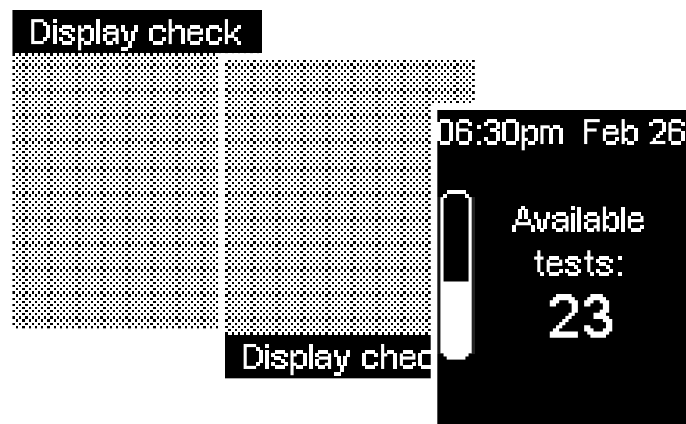

A beep will sound (if *Beeper* is turned on) and the display check will be displayed, followed by the number of available tests.

- 2 Check that there are no irregularities in the checkerboard pattern.

Then the meter advances a test area to the tip of the cassette.

Shortly after the test area has been advanced to the tip of the cassette, the prompt *Apply blood* will appear and a beep will sound (if *Beeper* is turned on). The prompt also applies to control solution.

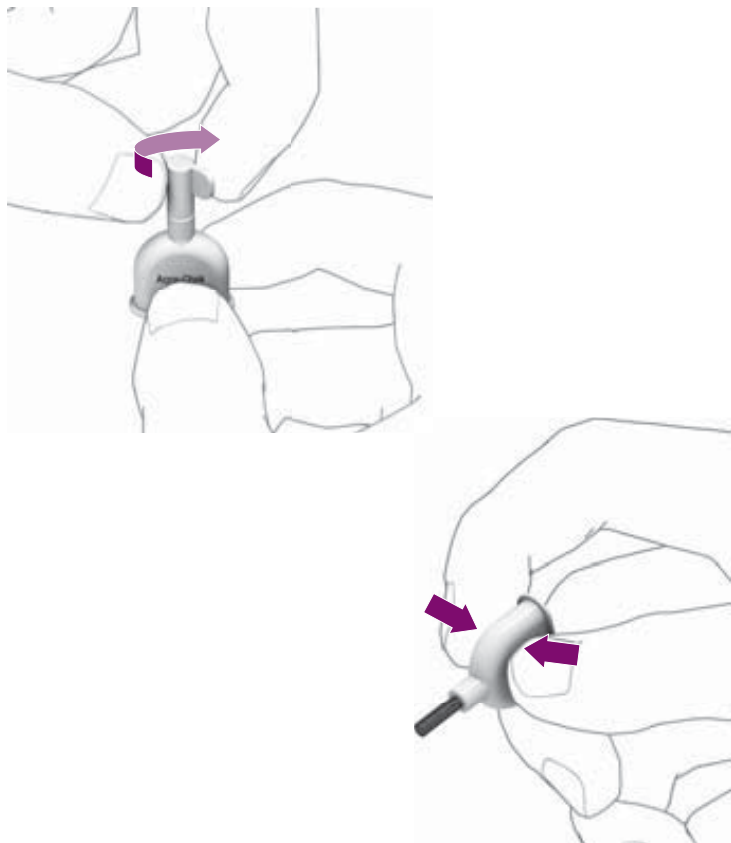

3 Twist the cap off the applicator vial. Be careful not to squeeze the vial too hard while doing this so as to not lose any control solution.

4 Hold the vial at a slight angle with the brush pointing downwards.

5 Squeeze the vial gently until you see a small drop appear at the end of the brush.

6 Then stop squeezing.

The drop will then be drawn back into the brush. The brush is now ready to use.



You can hold the meter in your hand or lay it down while you apply control solution to the test area.



Do not hold the meter with the test area pointing upwards. If you hold the meter with the test area pointing upwards, control solution could enter the meter and soil it.

- 7 Apply the control solution to the centre of the test area at the tip of the cassette using the tip of the brush.

As soon as control solution touches the test area it is drawn up.





- 8 Take the brush away from the test area as soon as *Test in progress* and the hourglass symbol appear on the display.



The test area has then drawn up enough control solution and a beep sounds (if *Beeper* is turned on). The hourglass symbol indicates that the test is in progress.

Testing is complete after approx. 5 seconds and the result appears on the display.

 The meter cannot distinguish between blood and control solution. If you have set a target range and the result obtained with control solution is outside this range, the symbol  will be displayed together with the result. The symbol will be deleted automatically when you flag the result as a control test.

To distinguish the control test later from blood glucose results, you need to flag it as a control test.

9 Press  (*Set flag*).

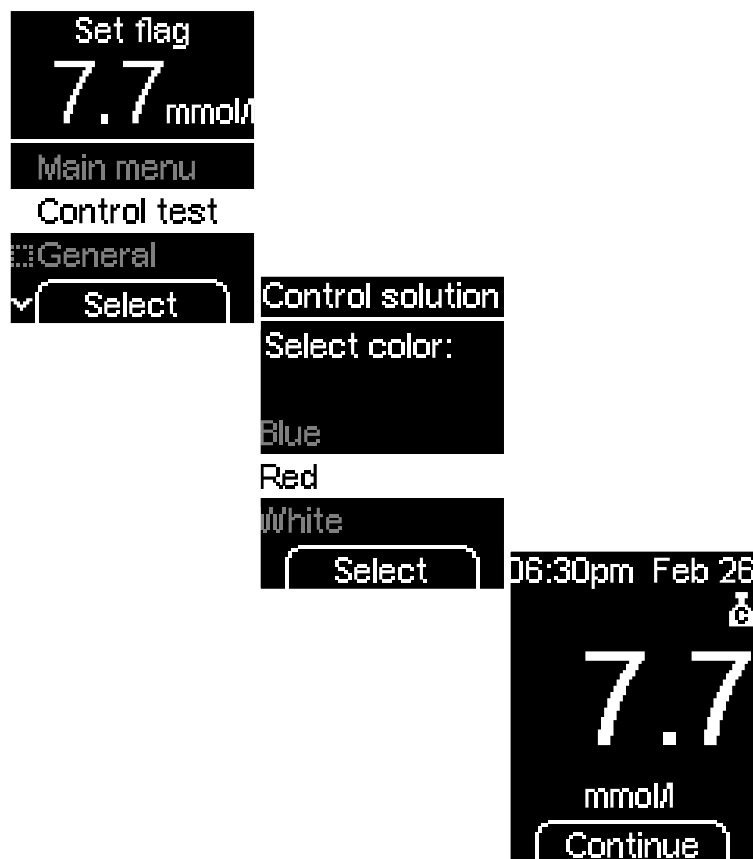

10 Use to select *Control test*.

11 Press (*Select*).

The meter then prompts you to enter the color of the vial label. Entering the correct color is important so that the meter can check whether the result is correct.

12 Use to select the color.

13 Press (*Select*).

The result is then displayed again, this time with the flag Control test (symbol).

14 Press (*Continue*).

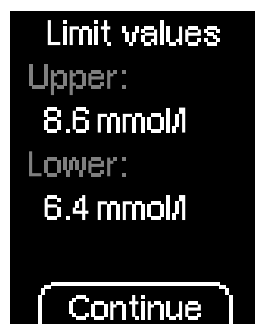

Values are only examples

The meter displays the upper and lower limits of the concentration range. The concentration range displayed depends on the color of control solution selected.

15 Press  (*Continue*).

The meter automatically checks whether the result is within the concentration range displayed.

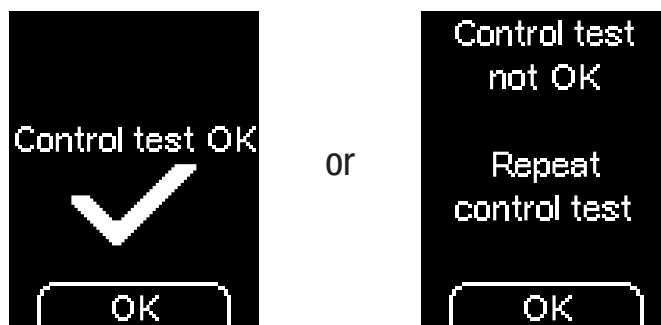

If the result is within the concentration range displayed, *Control test OK* is displayed.

If the result is not within the concentration range displayed, *Control test not OK Repeat control test* will be displayed (see Chapter “Control test not OK – possible sources of error”).

16 Press  (*OK*).



The meter returns to the *Main menu*.

17 Turn off the meter with  or via *Turn off*.

18 Close the tip cover.

19 Dispose of the vial in your household waste.



You can also check yourself whether the result is within the right concentration range.

To do this, compare the result with the concentration table on the test cassette box.

The result must be within the printed concentration range.

Make sure you compare the result with the concentration range that corresponds to the control solution you used (1 or 2) and to the unit of measurement your meter displays (mmol/l or mg/dl).

	Accu-Chek® Mobile Control		Unit of measurement
	mg/dl	mmol/l	
1	35 - 75	1,9 - 4,2	
2	115 - 155	6,4 - 8,6	

Values are only examples

Control solution used

Control test not OK – possible sources of error



If *Control test not OK Repeat control test* is displayed, the result obtained is not within the concentration range displayed. Check the points listed on the next page. If your answer is different from the answer given, make the respective corrections and repeat the test. If you have taken all of these points into account and *Control test not OK* is still displayed, contact your customer support and service centre.



If *Control test not OK Repeat control test* is displayed, it is no longer certain that the meter and test cassette are functioning properly. Blood glucose tests may then deliver incorrect results. Incorrect results can cause the wrong therapeutic decision to be taken and so produce serious adverse health effects.

Did you perform the control test according to the User's Manual?	yes
Did you wait for the application prompt to be displayed before applying control solution?	yes
Did you apply the control solution immediately after opening the vial?	yes
Did you enter the correct color?	yes
Did you perform the test within the correct temperature range (10–40 °C)?	yes

Has the expiry date for the control solution been reached (see label on the bottom of the vial next to the symbol )? no

Did you observe the proper storage conditions for the meter, test cassette and control solutions (see Chapter 15 and the test cassette and control solution package inserts)? yes

If your meter has been dropped, that can also lead to control test results which are not within the concentration range displayed and for which *Control test not OK* is displayed. In this case, you should also call your customer support and service centre.

8 Tools menu



The *Tools* menu on the one hand offers you some extra means of checking the meter. On the other hand, you must also use this menu to prepare for cleaning the meter and changing a test cassette that has not been used up.





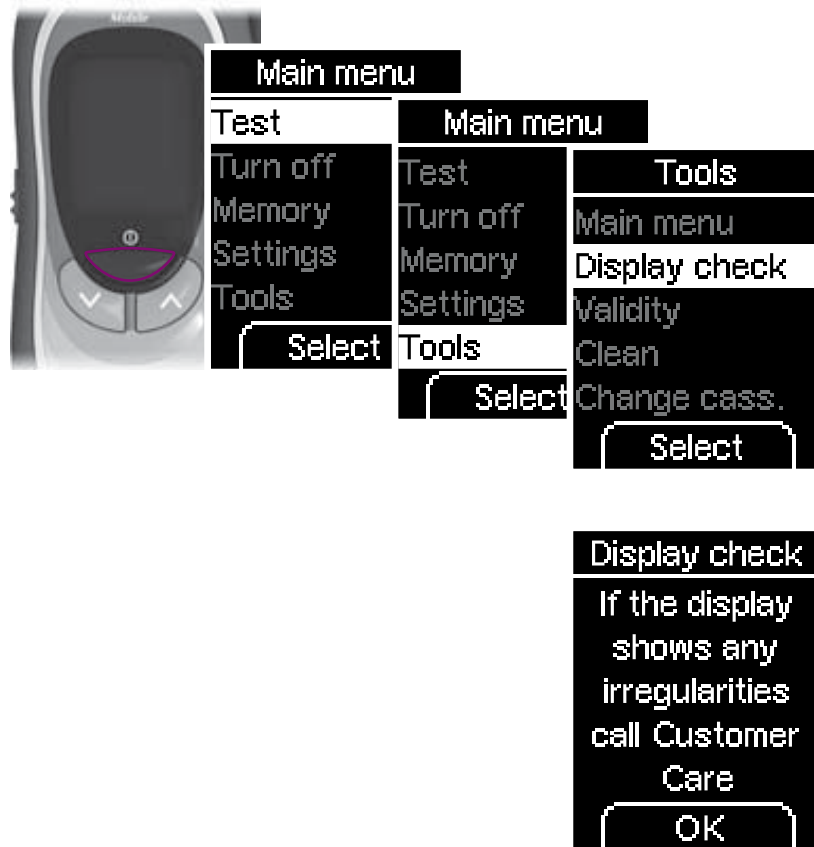

The following options are available in the Tools menu:

- *Main menu*: takes you to the Main menu
- *Display check*: perform a separate display check (see Chapter 9)
- *Validity*: perform a separate display check (see Chapter 9)
- *Clean*: prepare the meter for cleaning (see Chapter 11)
- *Change cass.*: prepare the meter for removing a test cassette which still has unused test areas (see Chapter 12)

9 Performing a display check



If you wish to check whether the display is working properly, you can also do this, in addition to after turning on the meter, via the display check in the Tools menu. In this case, the display check is displayed not only for about 2 seconds, but until you cancel it (but not longer than 1 minute).

- 1 Turn on the meter with ,
 - wait for the *Main menu*,
 - use   to select *Tools*,
 - press  to open *Tools*,
 - use   to select *Display check*,
 - press  to open *Display check*.

- 2 Press  (OK).

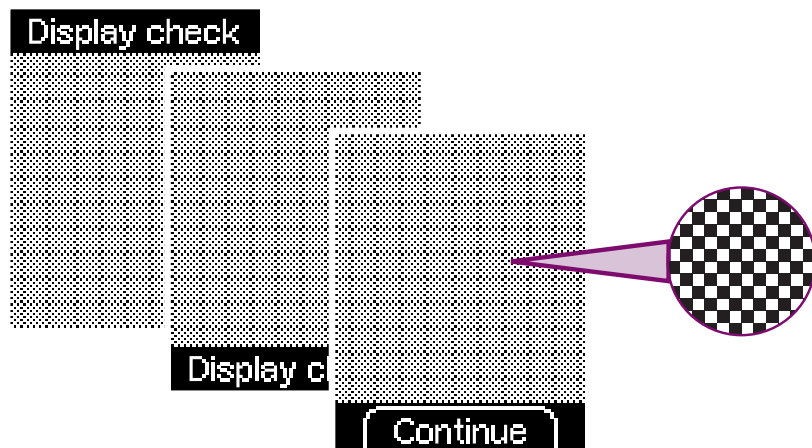

Display check without irregularities

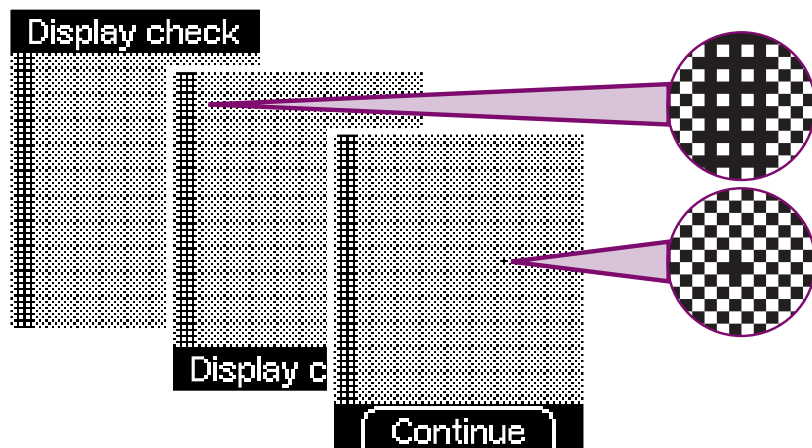

Display check with irregularities (examples)

- 3 Check whether there are any irregularities in the checkerboard pattern.



If there are irregularities in the checkerboard pattern, results might not be displayed correctly. In this case, ask your dealer to change the meter or contact your customer support and service centre.

- 4 Press the  button (*Continue*).





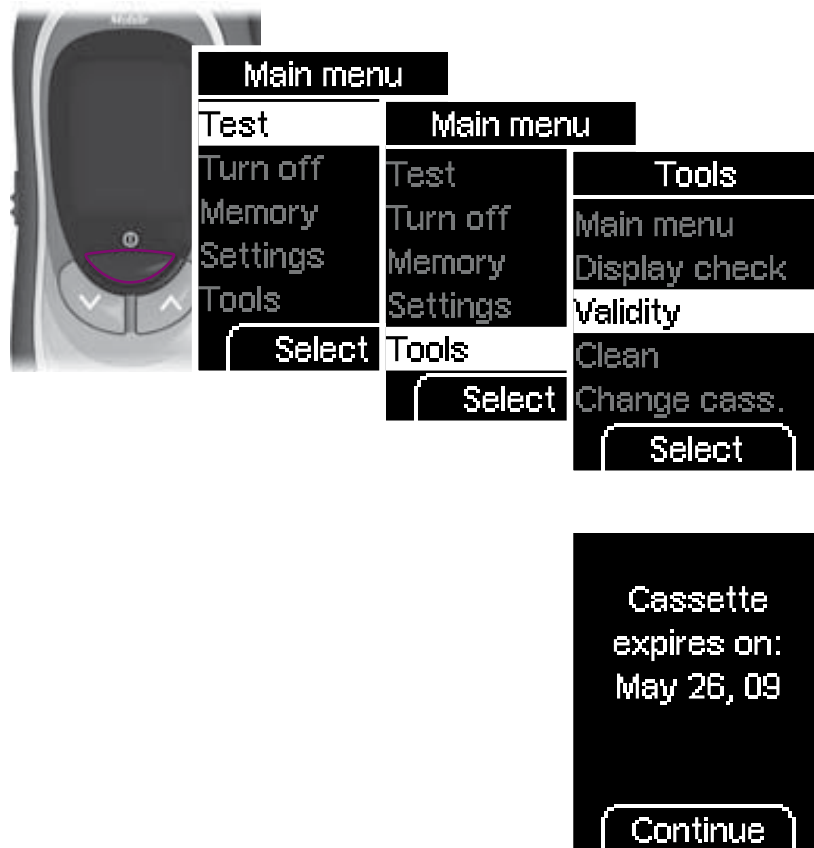

The meter returns to the Tools menu.

If you do not press the  button, the meter displays the display check for about 1 minute. Then it displays the number of available tests and turns off automatically.

10 Viewing the validity of the test cassette



You can check how long the test cassette in the meter is valid as follows:

- 1 Turn on the meter with ,
 - wait for the *Main menu*,
 - use   to select *Tools*,
 - press  to open *Tools*,
 - use   to select *Validity*,
 - press  to open *Validity*.

The validity is displayed.

- 2 Press  (*Continue*).

The meter returns to the Tools menu.

11 Cleaning the meter and lancing device

11.1 Cleaning the meter

The mode of operation of the meter with the test cassette means that the meter will not normally come into contact with blood or control solution. Regular cleaning is therefore not necessary. In the event of the meter becoming soiled through improper use, cleaning it may become necessary.



Use **only** cold water or 70 % ethanol for cleaning. Any other cleaning agents may damage the meter or impair its measuring function.

Use a lightly moistened cloth or a lightly moistened cotton swab. Do not spray anything onto the meter and do not immerse it in the cleaning fluid. Doing so may damage its internal components and stop it from working properly.

The outside

If the casing of the meter or the display is visibly soiled:

wipe these with a cloth lightly moistened with cold water or 70 % ethanol.

The inside

You only need to clean the inside of the meter if





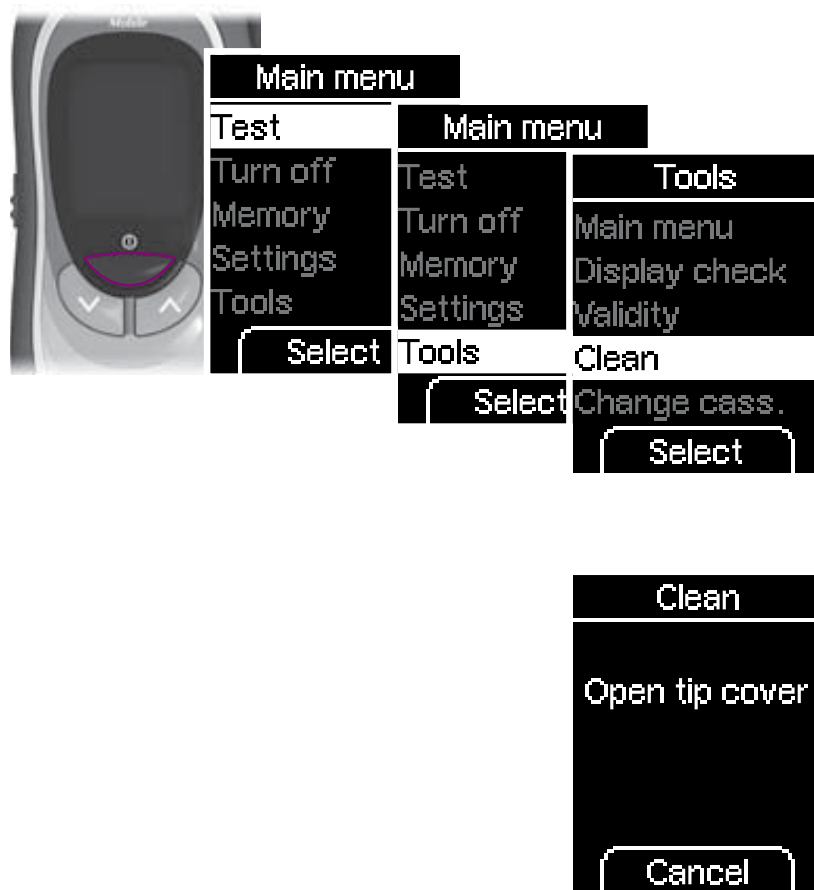

- the area around the tip of the cassette is visibly soiled,
- the error message E-1 with the text “*Cassette problem Insert new cassette*” is displayed; the error message might be caused by a fault in advancing the test area to the tip of the cassette,
- the error message E-4 with the text “See User’s Manual” is displayed; the error message might be caused by fluff, crumbs or the like inside the tip of the cassette.

To enable you to clean the inside of the meter, you have to open *Clean* in the *Tools* menu and then remove the test cassette



If the error message E-4 was displayed, a test area is lost when you later reinsert the test cassette.



- 1 Turn on the meter with ,
 - wait for the *Main menu*,
 - use   to select *Tools*,
 - press  to open *Tools*,
 - use   to select *Clean*,
 - press  to open *Clean*.

The meter now prompts you to open the tip cover.

If you do not want to clean the meter after all, you can abort the preparation using the  button (*Cancel*).



Clean

Remove cassette

Clean meter

2 Place your finger on the corrugated area on the tip cover and push it in the direction of the arrow as far as it will go.

The meter then prompts you to remove the test cassette. About 2 seconds later, it turns off automatically.

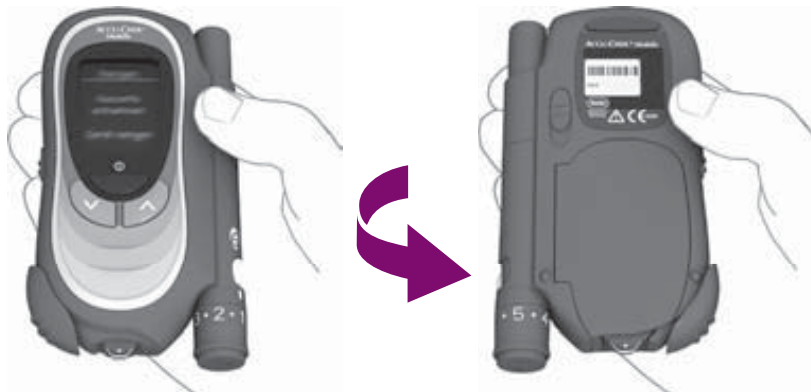

3 Turn the meter over.

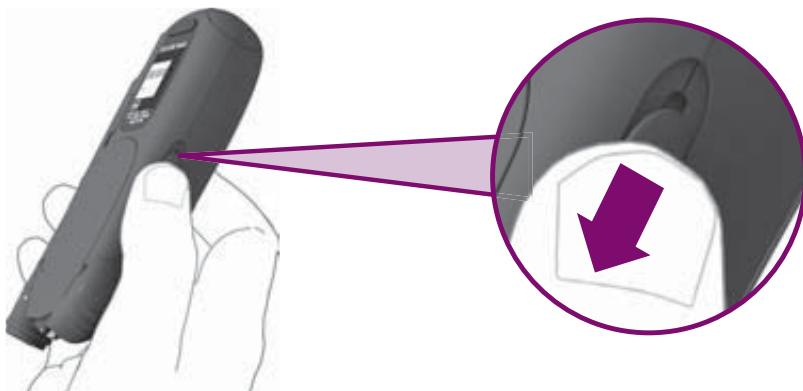

- 4 Push the release button for the cassette compartment cover in the direction of the arrow. The cover springs open.



- 5 Open the cassette compartment cover all the way. You have to overcome a resistance just before it is fully opened.



The cassette compartment cover is fully opened when it is at an angle of slightly more than ninety degrees – as shown in the illustration.



6 Remove the cassette from the cassette compartment.



7 Check whether you can see any fluff, crumbs or the like inside the tip of the cassette.

8 If so, remove these carefully.

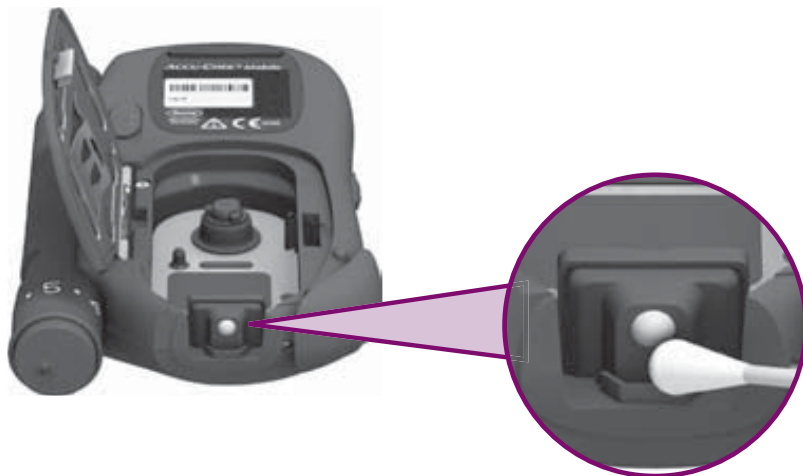

If the measuring optics are visibly soiled, clean the inside of the meter as follows:

- 9** Carefully wipe the measuring optics and the front opening of the meter with a lightly moistened cloth or cotton swab.

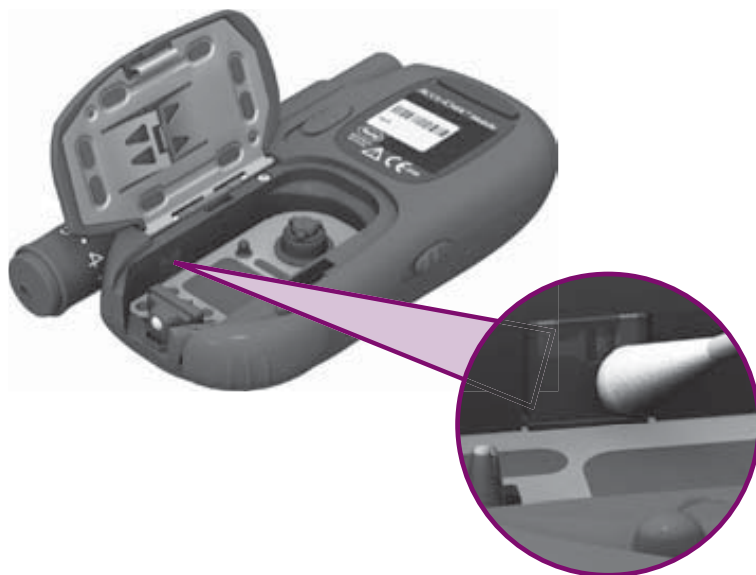

- 10** Carefully wipe the sensors on the inside wall of the meter with a lightly moistened cloth or cotton swab.



Make sure that no liquid enters the meter. Avoid scratching the measuring optics and the sensors. Scratches could interfere with tests or the advancing of test areas to the tip of the cassette.



11 Leave the cassette compartment cover open and close the tip cover.

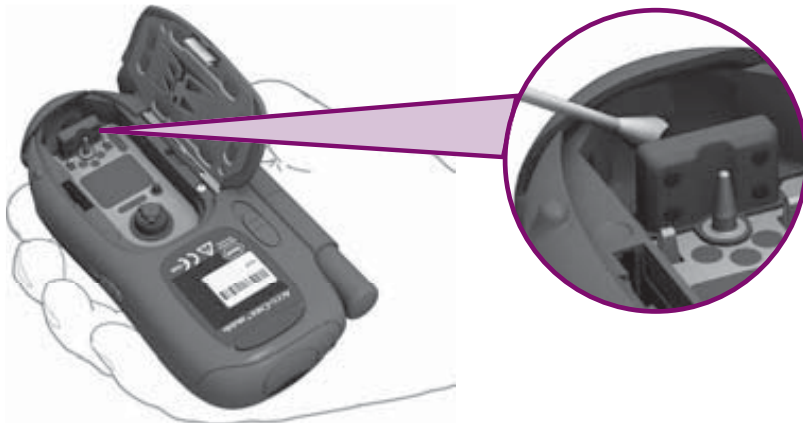

12 Carefully wipe the inside of the tip cover with a lightly moistened cloth or cotton swab.

13 Remove any fluff or lint that may remain.

14 Allow the meter time to dry thoroughly.



15 Open the tip cover again.

The meter now turns on and displays error message E-2. The error message at this point is not relevant since you had to remove the cassette to clean the meter. You can ignore the message. The meter turns off again automatically. Simply continue with step 16.

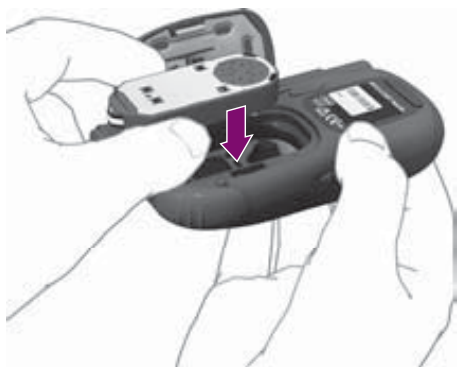

16 Insert the cassette in the meter again with the silver side facing upwards.

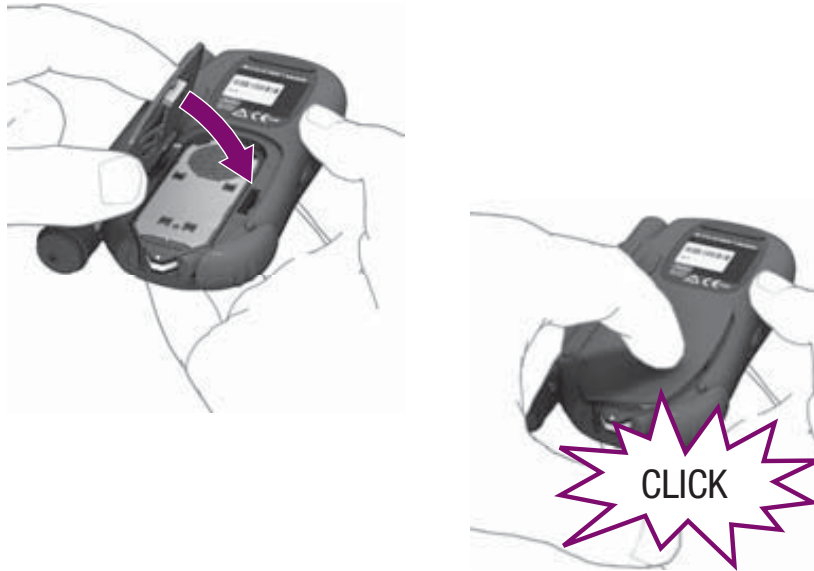

17 Close the cassette compartment cover and press it closed. You must hear an audible **CLICK**.



18 Close the tip cover.

11.2 Cleaning the lancing device

To ensure proper functioning of your lancing device, you should clean it regularly and if there is any blood on it. If you want to clean the lancing device, first detach it from the meter (see Chapter “Undocking and docking the lancing device”).

Clean the outside of the lancing device only. Wipe it once a week with a cloth moistened with 70 % ethanol or 70 % isopropanol (available from your pharmacy).

Also clean the inside of the cap with a cotton swab moistened with one of the two cleaning fluids.

Allow the lancing device and cap time to dry thoroughly.



Never dip the lancing device in cleaning fluid. Doing so may damage its internal components and stop it from working properly.



Use only 70 % ethanol or 70 % isopropanol to clean the lancing device. Other cleaning agents may attack the plastic and stop the lancing device from operating properly.

12 Replacing the test cassette

If you want to replace an empty test cassette or an expired test cassette, please continue reading in Chapter 12.2.





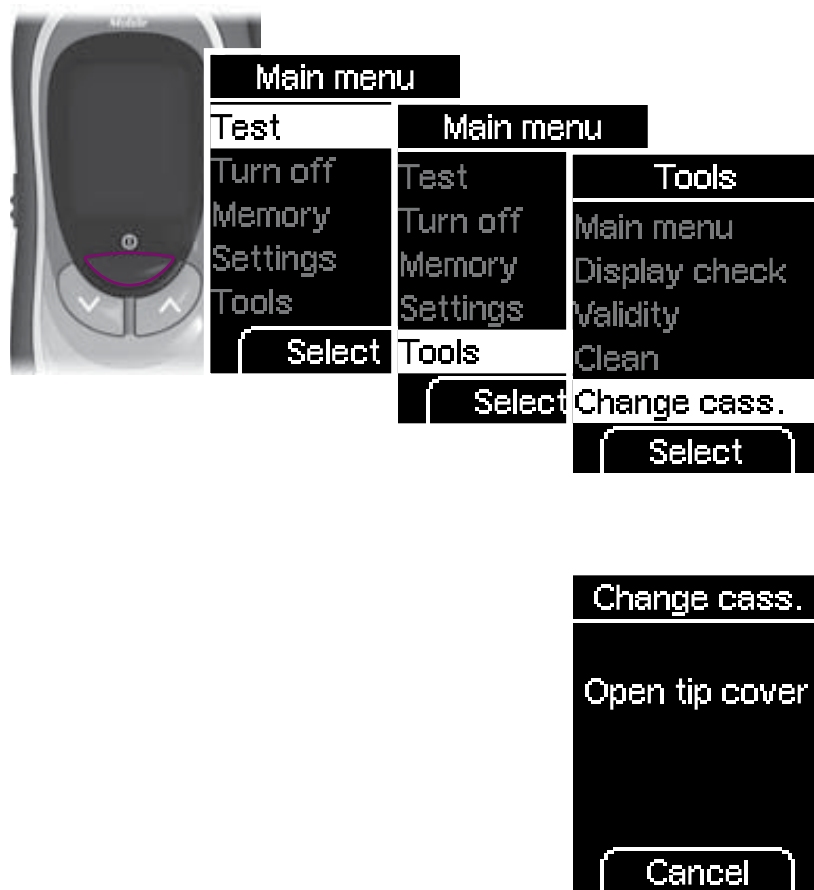

If you want to remove a started test cassette which still has unused test areas, you must first perform the preliminary steps described in Chapter 12.1.

You can reinsert a started cassette into the meter at a later date. In the mean time, store this cassette in a dry place protected from light.

 If you reinsert the started cassette into the meter and there was another cassette in the meter before this, the started cassette loses a test area. If you reinsert the started test cassette into the meter immediately, it does not lose a test area.

12.1 Preparing cassette replacement



- Turn on the meter with ,
- wait for Main menu,
- use   to select *Tools*,
- press  to open *Tools*,
- use   to select *Change cass.*,
- press  to open *Change cass.*

The meter now prompts you to open the tip cover.

If you do not want to change the cassette after all, you can abort the preparation using the  button (*Cancel*).

12.2 Replacing the cassette



Change cass.
Change
cassette
and then
close tip cover

06:30pm Feb 26
Cassette
empty
Insert new
cassette

or

06:30pm Feb 26
E-1
Cassette
problem
Insert new
cassette

or

06:30pm Feb 26
Cassette
expired
Insert new
cassette

- 1 Place your finger on the corrugated area on the tip cover and push it in the direction of the arrow as far as it will go.

If you have prepared for the cassette **replacement via *Change cass.*** the meter prompts you to replace the test cassette. Shortly after this, it turns off automatically.

If the **cassette** in the meter is **empty** or **defective** or has **expired**, the appropriate message or error message E-1 appears after the display check and the number of available tests (see also Chapter 16.2 and 16.4). Shortly after this, the meter turns off automatically.

Replacing the test cassette



2 Turn the meter over.

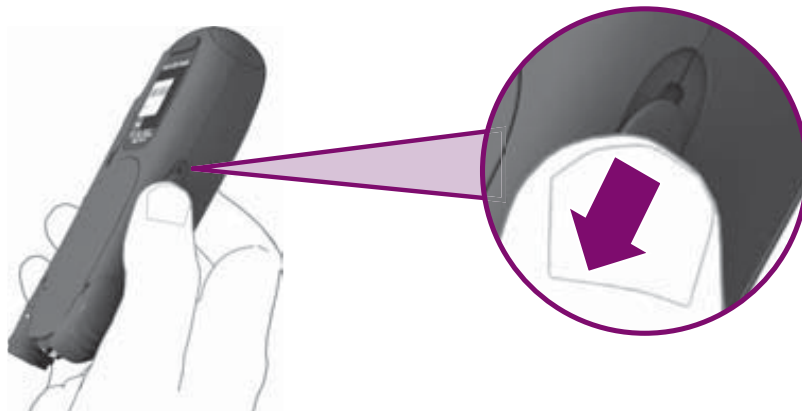

3 Push the release button for the cassette compartment cover in the direction of the arrow. The cover springs open.

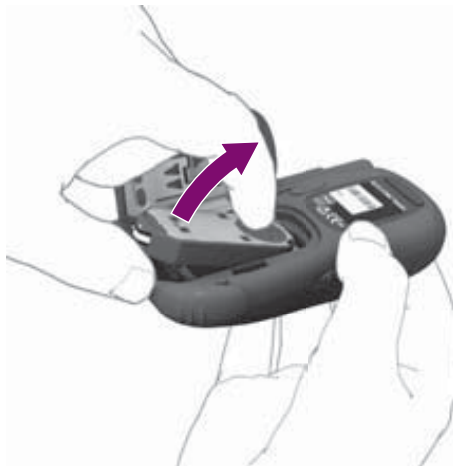

- 4 Open the cassette compartment cover all the way. You have to overcome a resistance just before it is fully opened.

The cassette compartment cover is fully opened when it is at an angle of slightly more than ninety degrees – as shown in the illustration.

- 5 Remove a new cassette from the packaging.

Insert the cassette in the meter with the silver side facing upwards.



6 Remove a new cassette from the packaging.

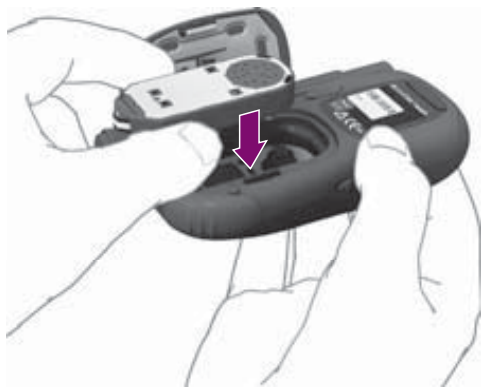

7 Insert the cassette in the meter with the silver side facing upwards.

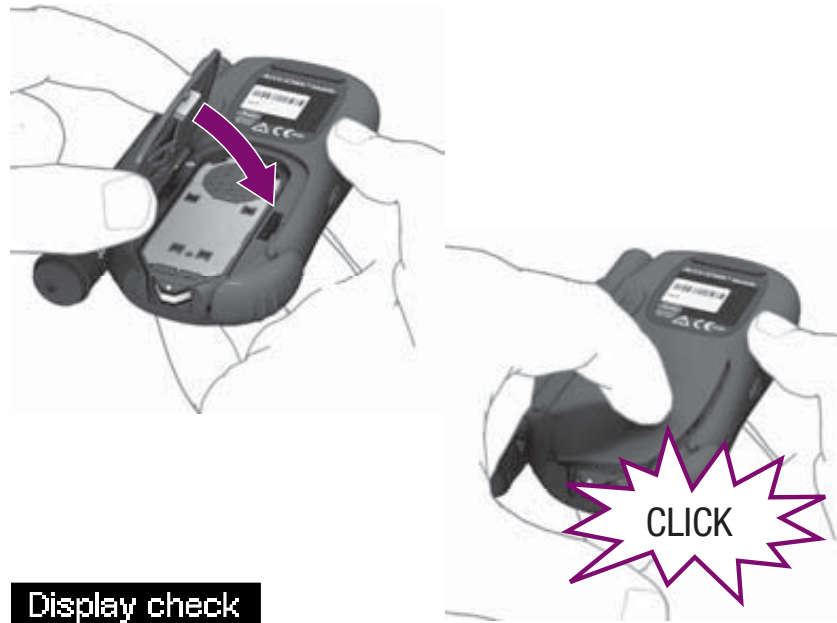

8 Close the cassette compartment cover and press it closed. You must hear an audible CLICK.

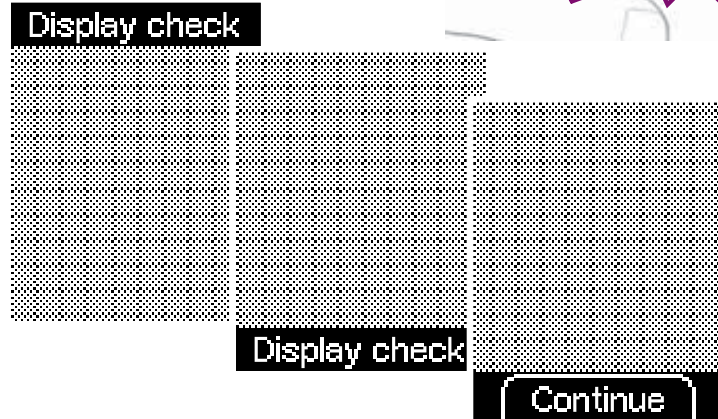

When you have closed the cassette compartment cover, the meter turns on again and runs the display check.

9 Press the  button (*Continue*).

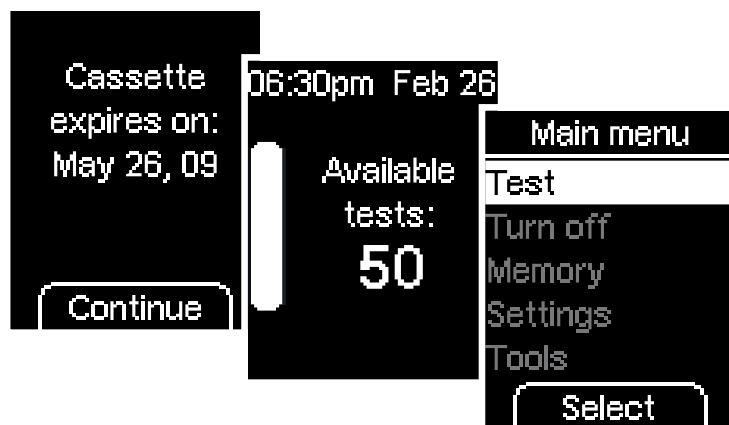

The validity of the cassette is displayed.

10 Press the  button (*Continue*).

The meter displays the number of available tests and then opens the Main menu.

11 Close the tip cover.

If the test cassette you removed still has unused tests and has not yet expired, you can reinsert the cassette into the meter at a later date. The meter recognizes the cassette, the number of available tests and the validity.

13 Viewing the number of available tests

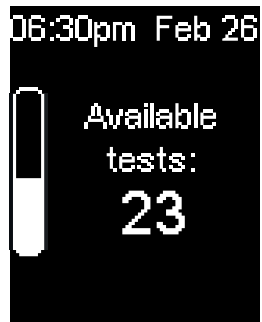

You can view the number of tests still available on the inserted cassette by one press of a button.

With the meter off:

Press and hold the  button until the meter turns on (longer than 2 seconds).

The number of tests available on the cassette will be displayed. The meter turns off again automatically a short time later.

14 Changing the batteries



This message appears when the batteries are almost empty. It appears every time you turn the meter off if you have not yet changed the batteries. The first time the message appears, you can still perform about 50 tests.

However, we recommend that you replace the batteries as soon as possible. By then the batteries will have been heavily drained and changeable conditions (e.g. cold outside temperatures) can affect their performance even further.

You need 2 alkaline-manganese or high-energy batteries type AAA, LR 03, AM4 or micro (1.5 V). Always replace both batteries at the same time.

Do not use rechargeable batteries as these have a considerably shorter life than normal batteries.

With a new set of batteries, you can perform at least 500 tests or test for about 1 year.

Results and settings remain saved in the meter while you change the batteries or if you store the meter without batteries.

The meter has an inbuilt back-up battery. This provides the power when there are no batteries inserted. The back-up battery lasts about 5 years. It cannot be replaced if it is empty. An empty back-up battery has no influence on the functioning of the meter.

If the back-up battery is empty, you still have 10 minutes to change the batteries. Only if more time than this elapses does the meter forget the time and date and dashes appear on the display instead of the time and date. In this case, set the time and date again.



Never throw batteries into a fire. This is dangerous, because they may explode.



Please dispose of used batteries in an environmentally friendly way at a collection depot or through your dealer.



Remove the batteries if you will not be using your meter for any length of time. The time and date still remain saved in the meter.



- 1** Push the battery compartment cover in the direction of the arrow as far as it will go to unlock it. You will have to overcome a slight resistance. The cover is properly unlocked when it slides over this resistance with a **CLICK**.



- 2** Raise the battery compartment cover as illustrated.



3 Turn the meter so that the battery compartment faces downwards. The batteries fall out.



4 Insert two new batteries in the battery compartment. Pay attention to the symbols **+** and **-** in the battery compartment. The corresponding end of the battery must be facing upwards.

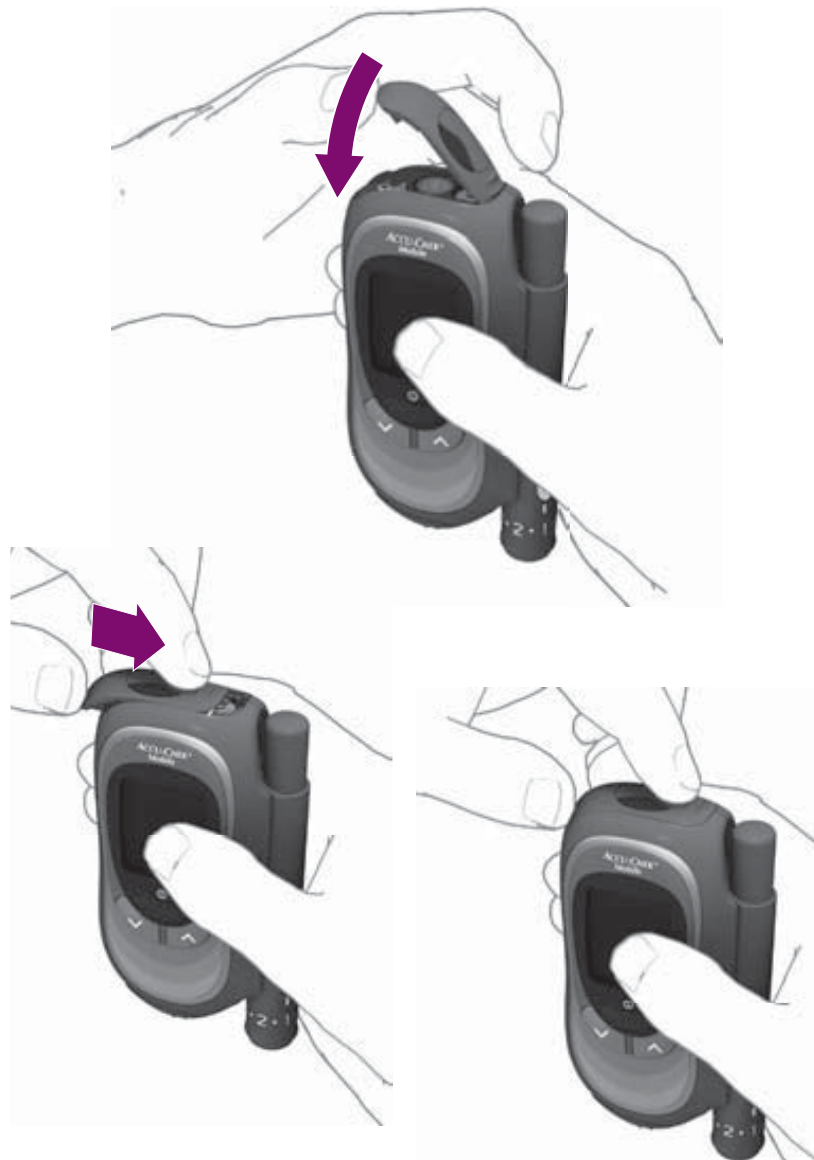

5 Close the battery compartment cover again.

6 Push the battery compartment cover in the direction of the arrow as far as it will go to lock it. It locks into place with a CLICK.

15 Testing and storage conditions

So that the meter and lancing device work reliably and you obtain accurate results, make sure that the conditions listed on the following pages are met.

15.1 Temperature

- **Without** batteries and **without** a test cassette, the meter should be stored at between -25 and $+70$ °C.
- **With** batteries and **without** a test cassette, the meter should be stored at between -10 and $+50$ °C.



At temperatures above $+50$ °C, the batteries could leak and damage the meter.



At temperatures below -10 °C, the batteries do not have enough power to keep the internal clock functioning.

- **With** batteries and **with** a test cassette, the meter should be stored at between -6 and $+40$ °C.

- For blood glucose tests and control tests, the permitted temperature range is between $+10$ and $+40$ °C.
- If the temperature is between $+6$ and $+10$ °C or between $+40$ and $+44$ °C, the meter will still allow you to perform a test. However, the following warning will appear (see also Chapter 16.2).

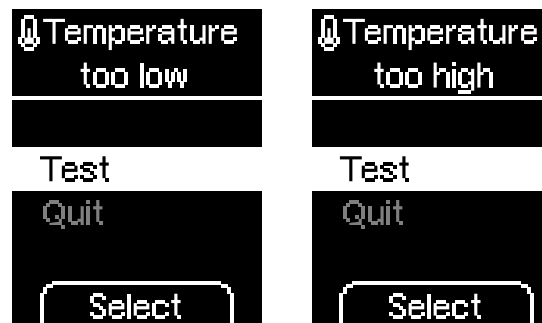

Do not use blood glucose results obtained despite this warning as a basis for making therapeutic decisions. These results may be incorrect. Incorrect results can cause the wrong therapeutic decision to be taken and so produce serious adverse health effects.

- Tests cannot be performed at temperatures below +6 and above +44 °C. In this event, the following error message appears:

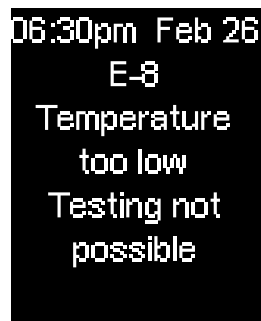

06:30pm Feb 26
E-8
Temperature
too low
Testing not
possible

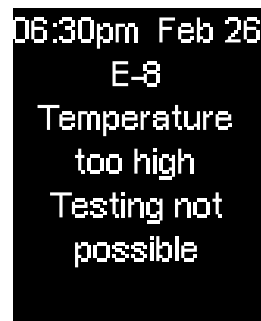

06:30pm Feb 26
E-8
Temperature
too high
Testing not
possible



Never try to speed up the cooling or warming of your meter, e.g. by placing it in the refrigerator or on a radiator. Doing so can damage the meter and cause it to deliver incorrect results. Incorrect results can cause the wrong therapeutic decision to be taken and so produce serious adverse health effects.

- Do not store the lancing device in a primed state and do not store it for any length of time in a place where the temperature is very low or high, e.g. in a hot car. This can cause parts of the lancing device to become warped, so impairing its operation.

15.2 Humidity

Only perform blood glucose tests at a relative humidity between 15 and 85 %.

Store the meter in a place with a relative humidity between 15 and 93 %.



Sudden changes in temperature can cause condensation to form in or on the meter. If this happens, do not turn the meter on. Make sure that it returns to ambient temperature slowly. Never store the meter in a room that is likely to harbour condensation (e.g. bathroom).

15.3 Light conditions

Displayed text, numbers and symbols appear yellow. Bright light shining on the display may make them difficult to read. Shield the meter if necessary, with your body, for example.



Keep the meter away from very strong light sources (e.g. direct sunlight, spot lights). These may interfere with the proper functioning of the meter and lead to error messages.

15.4 Local sources of interference



Strong electromagnetic fields may interfere with the proper operation of the meter. Do not use the meter close to sources of strong electromagnetic radiation.



To avoid electrostatic discharge, do not use the meter in a very dry environment, particularly one in which synthetic materials are present.

NOTICE:

This device complies with Part 15 of the FCC Rules and with RSS-210 of Industry Canada.

Operation is subject to the following two conditions:

- (1) this device may not cause harmful interference,
and
- (2) this device must accept any interference received,
including interference that may cause undesired
operation.

NOTICE:

Changes or modifications made to this equipment not expressly approved by Roche Diagnostics GmbH, Germany may void the FCC authorization to operate this equipment.

Classification with respect to U.S. telecommunication requirements (47CFR §15.105)

NOTE:

This equipment has been tested and found to comply with the limits for a Class B digital device, pursuant to Part 15 of the FCC Rules. These limits are designed to provide reasonable protection against harmful interference in a residential installation. This equipment generates, uses and can radiate radio frequency energy and, if not installed and used in accordance with the instructions, may cause harmful interference to radio communications. However, there is no guarantee that interference will not occur in a particular installation. If this equipment does cause harmful interference to radio or television reception, which can be determined by turning the equipment off and on, the user is en-

couraged to try to correct the interference by one or more of the following measures:

- Reorient or relocate the receiving antenna.
- Increase the separation between the equipment and receiver.
- Connect the equipment into an outlet on a circuit different from that to which the receiver is connected.
- Consult the dealer or an experienced radio/TV technician for help.

Classification with respect to the Canadian telecommunication requirements

NOTICE:

This Class B digital apparatus complies with Canadian ICES-003.

16 Symbols, messages, problems and error messages

16.1 Symbols

The meter presents most of the information as text. In addition, results are displayed – both after a test and in the memory – together with further information in the form of symbols.



The batteries are almost empty.



This is the result of a control test.



The temperature during the test was outside the permitted range of +10 to +40 °C. Despite a warning to this effect you decided to go ahead with the test.



You have turned on a target range. The result is either below the lower limit or above the upper limit of the target range set.



in place of a result: The result is lower than 0.6 mmol/l.



LO may indicate that your blood glucose is very low (possibly a severe hypoglycemia). Follow the relevant instructions given by your doctor immediately and repeat the test.



in place of a result: The result is higher than 33.3 mmol/l. Repeat the test.



You have flagged the result with the flag *General*.



You have flagged the result with the flag *Before meal*.



You have flagged the result with the flag *After meal*.

16.2 Messages

06:30pm Feb 26
Cassette
empty
Insert new
cassette

Cassette
expires in
10 days
Continue

06:30pm Feb 26
Cassette
expired
Insert new
cassette

Cassette empty: This message appears if you start a test and all test areas in the cassette have been used.

Insert a new test cassette in the meter.

Validity of the cassette: This message appears at the start of a test if the test cassette is only valid for 10 more days. The message is repeated when the cassette is only valid for 5, 2 and 1 more day(s).

Press the  button (*Continue*) to start a test.

Cassette expired: This message appears if the cassette has been in the meter for longer than 3 months or is expired.

Insert a new test cassette in the meter.



Batteries low: This message appears when the batteries are almost empty. It appears every time you turn the meter off if you have not yet changed the batteries. The first time the message appears, you can still perform about 50 tests.

Change the batteries as soon as possible.

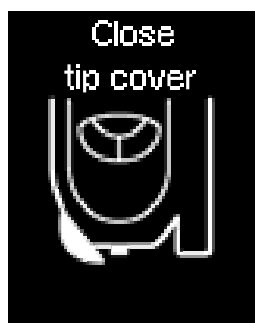

Close tip cover: This prompt appears if the tip cover is open and needs to be closed:

- when you turn off the meter after a test
- when you close the cassette compartment cover (after changing the cassette or cleaning)
- if you start a test via the Test menu and the tip cover is already open

Close the tip cover.

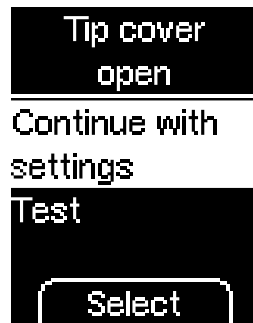

Tip cover open: This message appears if you are in the process of changing a setting (e.g. the date) or entering a new setting (e.g. a reminder) and open the tip cover.

Close the tip cover again if you wish to continue with the setting.

Close the tip cover again if you wish to continue with the setting.

Use to select whether you wish to *Continue with settings* or *Test*.

- *Continue with settings:* in this case, the meter prompts you to close the tip cover.
- *Test:* in this case, the setting procedure will be interrupted (any changes you have already made will be lost) and a test area will be advanced.

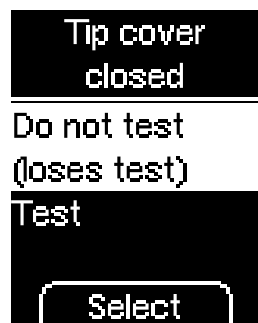

Tip cover closed: This message appears if you close the tip cover after the meter has advanced a test area.

Open the tip cover again if you wish to continue with the test.

or

Use   to select *Do not test* or *Test*.

- *Do not test:* in this case, the meter returns to the Main menu. You can no longer use the test area, because the meter will advance the tape again. This reduces the number of available tests.
- *Test:* in this case, the meter prompts you to open the tip cover.

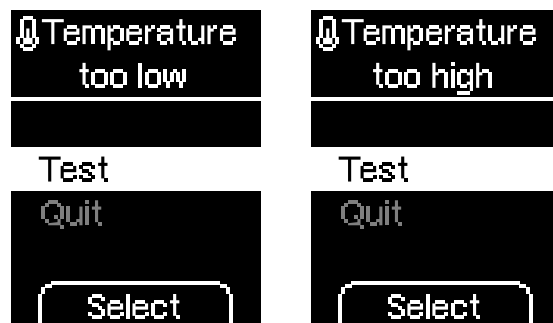

Temperature too low / too high: This message appears at the start of a test if the ambient temperature or the temperature of the meter is between +6 and +10 °C or between +40 and +44 °C.

Use  , to select whether you wish to *Test* or *Quit*.

- *fortsetzen*: in this case, the meter advances a test area.
- *Quit*: in this case, the meter returns to the Main menu. Close the tip cover.

If you decide to perform the test in spite of the warning, the result will be flagged and saved with the symbol .

 Do not use blood glucose results obtained despite this warning as a basis for making therapeutic decisions. These results may be incorrect. Incorrect results can cause the wrong therapeutic decision to be taken and so produce ser-

ious adverse health effects. Move to a place where the temperature is between +10 and +40 °C and wait for the temperature of the meter to adjust to this temperature.

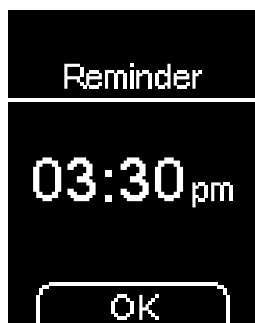

Reminder: If you have set reminders, this message appears at the set time. If you have also turned on *Reminders* in the *Settings/Tones* menu, beeps will also sound.

To turn off the reminder:

Press any button.

16.3 Problems

The meter will not turn on.

- The batteries are empty or none are inserted.

Insert new batteries.

- You have inserted the batteries the wrong way round.

Remove the batteries and reinsert them as shown in the battery compartment.

- The ambient temperature is low and the batteries are almost empty.

Move to a place where the temperature is between +10 and +40 °C and wait for the temperature of the meter to adjust to this temperature. Insert new batteries.

- Condensation has affected the electronics.

Allow the meter time to dry slowly.

- The meter is defective.

Contact your customer support and service centre.

The meter only displays dashes instead of the time and date.

The meter has forgotten the time and date.

You have changed the batteries or stored the meter without batteries and the built-in backup battery is empty. The back-up battery normally ensures that the meter remembers the time and date even if no batteries are inserted.

Reset the time and date.

Results which are saved without the time and date cannot be analysed after transfer to a computer or only in a limited way.

If the back-up battery is empty you still have 10 minutes to change the batteries before the meter forgets the time and date. If more than 10 minutes elapse, only dashes are displayed instead of the time and date.

The meter is turned on, but the display remains blank.

The display is defective.

Contact your customer support and service centre.

16.4 Error messages

The following pages describe all error messages together with the cause and how they can be remedied.

If an error message is displayed, turn the meter off:

Press and hold the On/Off  button until the bar in the display is filled (at least 2 seconds).

If error messages occur frequently, contact your customer support and service centre.

If your meter has been dropped, that can also lead to error messages. In this case, you should also call your customer support and service centre.

E-1

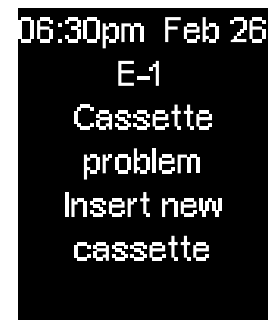

- The test cassette or the meter may be defective.

Remove the cassette from the meter and reinsert it.

- If the error message reappears:

Clean the meter and the test cassette.

- If the error message reappears:

Insert a new test cassette in the meter.

- If the error message still appears, the meter is defective.

Contact your customer support and service centre.

E-2

```
06:30pm Feb 26
E-2
See
User's Manual
```

- There is no test cassette in the meter.

Insert a new test cassette.

- The RFID sensor in the meter is defective.

Contact your customer support and service centre.

- The RFID chip on the cassette is damaged or missing. The cassette cannot be used.

Insert a new test cassette.

E-3

```
06:30pm Feb 26
E-3
See
User's Manual
```

A meter error occurred.

If the error message reappears after turning on the meter:

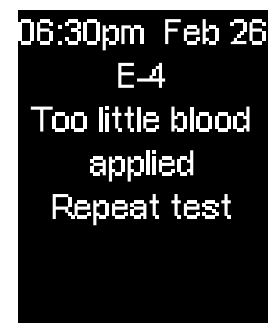
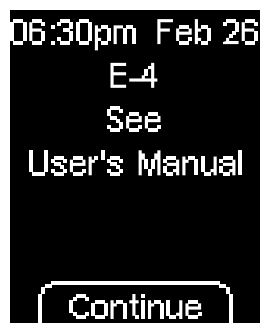

Contact your customer support and service centre.

E-4



- Fluff, crumbs or the like are inside the tip of the cassette.

Remove these. To do this, follow the instructions in Chapter 11.1.

 You can go directly from here to the Clean menu without having to turn the meter off first. To do this, press the  button (*Continue*).

- The cassette is not properly inserted into the meter.

Remove the cassette and reinsert it.

- The test area has drawn up too little blood or control solution.

Repeat the test with a larger amount of blood or control solution.

- You did not apply the blood drop or the control solution to the centre of the test area.

Repeat the test. Apply the blood drop or the control solution exactly to the centre of the test area at the tip of the cassette.

E-6

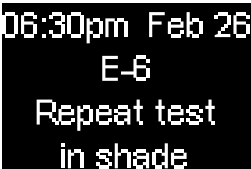

06:30pm Feb 26
E-6
Repeat test
in shade

During the test, bright light, e.g. sunlight, fell on the meter and has interfered with the test.

Move into the shade or shield the meter with your body, for example. Repeat the test.

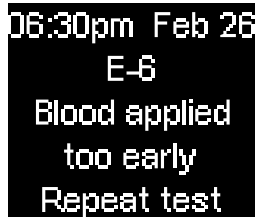

06:30pm Feb 26
E-6
Blood applied
too early
Repeat test

You applied blood or control solution to the test area too soon, i.e. before the prompt *Apply blood* was displayed.

Repeat the test. Do not apply blood or control solution to the test area until the prompt *Apply blood* is displayed.

E-7

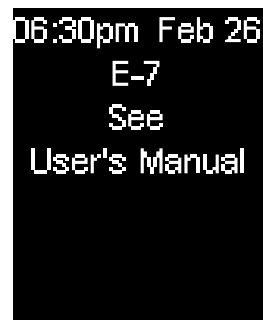

06:30pm Feb 26
E-7
See
User's Manual

A meter error occurred.
If the error message reappears after turning on the meter:

Contact your customer support and service centre.

E-8

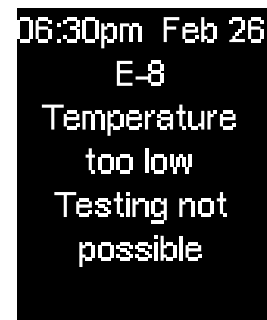

06:30pm Feb 26
E-8
Temperature
too low
Testing not
possible

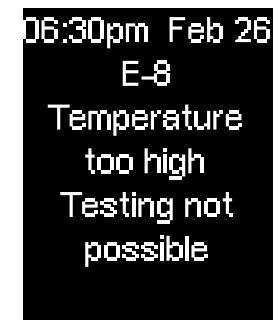

06:30pm Feb 26
E-8
Temperature
too high
Testing not
possible

The ambient temperature or the temperature of the meter is too low (under +6 °C) or too high (above +44 °C) for a test.

Move to a place where the temperature is between +10 and +40 °C and wait for the temperature of the meter to adjust to this temperature.

E-9

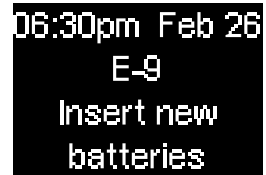

06:30pm Feb 26
E-9
Insert new
batteries

If the batteries are so low that no more tests can be performed, this message will appear for 3 seconds. Then the meter turns off.

Insert two new batteries.

17 Disposing of the meter

During blood glucose testing, the meter may come into contact with blood. Used meters therefore carry a risk of infection. Please dispose of your used meter, after removing the batteries, according to the regulations applicable in your country. Also remove the back-up battery (see next page).

For information about correct disposal, please contact your local council or authority.

The meter falls outside the scope of the European Directive 2002/96/EC (Directive on waste electrical and electronic equipment).



Please dispose of the batteries in an environmentally friendly way at a collection depot or through your dealer.

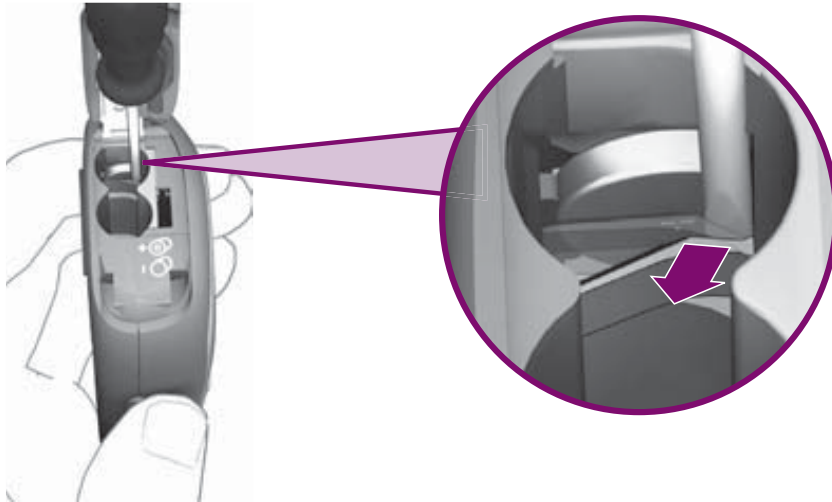

Removing the back-up battery

Apart from the two batteries in the battery compartment, there is also a third battery in the side of the battery compartment, the back-up battery.

You must also remove this battery before disposing of the meter.

Remove the back-up battery as follows:

- 1 Use a small screwdriver or similar implement to break out the partition wall in front of the battery.

The battery then drops into the battery compartment.

- 2 Turn the meter over so that the back-up battery falls out.

18 Technical data

Meter type	Accu-Chek Mobile
Catalogue No./ Serial No.	See type plate on the back of the meter
Test principle	<p>Determination of glucose in fresh capillary blood by reflectance photometry. When using different specimen material, please refer to the package insert that came with the Accu-Chek Mobile test cassette.</p> <p>Although you always apply whole blood to the test area, the blood glucose results displayed by your meter correspond to those in plasma.</p> <p>You will find information on how the system works, on the test principle and on reference methods in the Accu-Chek Mobile test cassette package insert.</p>
Measuring range	0,6–33,3 mmol/l
Sample size	approx. 0.3 µl (1 µL (microlitre) = 1 thousandth of a millilitre)
Measuring time	approx. 5 seconds (depending on the concentration)
Power supply	2 alkaline-manganese or high energy batteries (1.5 V, type AAA, LR 03, AM 4 or micro), back-up battery: 3V lithium button cell type CR1025
Battery life	at least 500 tests or approx. 1 year (less if the brightness of the display is set to level 3 or the volume is set to level 4 or 5 or in acoustic mode due to the higher power consumption)
Automatic power-off	after 1 or 2 minute(s), depending on the operating status

Temperature

during testing +10 to +40 °C

during storage

Meter	without batteries and without test cassette:	-25 to +70 °C
”	with batteries and without test cassette:	-10 to +50 °C
”	with batteries and with test cassette:	+6 to +40 °C

Humidity

during testing 15 to 85 % relative humidity

during storage 15 to 93 % relative humidity

Altitude

Sea level to 4000 m

Memory

500 results with time and date, averages for 7, 14 and 30 days

Dimensions

123 × 66 × 28 mm with lancing device

Weight

approx. 150 g with lancing device, batteries, test cassette and lancet drum

Display

OLED (Organic Light Emitting Diode) display

Interface

Infrared window

Safety class

III

LED/IRED

Class 1

Electromagnetic compatibility

This instrument meets the electromagnetic immunity requirements according to EN ISO 15197 Annex A. The chosen basis for the immunity tests (on electrostatic discharge) was basic standard IEC 61000-4-2.

In addition, the instrument meets the electromagnetic emissions requirements according to EN 61326. Its electromagnetic emission is thus low. Interference with other electrically powered equipment is not to be anticipated.

Performance evaluation

The performance data for the Accu-Chek Mobile system (Accu-Chek Mobile meter with Accu-Chek Mobile test cassette) were determined using capillary blood from patients with diabetes (method comparison, accuracy), venous blood (repeatability) and control solutions (reproducibility). The system is calibrated with venous blood containing various levels of glucose. The reference values are obtained using the hexokinase method. The method comparison was conducted by comparing the results from the system with those of the hexokinase method with deproteination using an automatic analyzer. The hexokinase method is traceable to an NIST standard (traceability).

The Accu-Chek Mobile blood glucose monitoring system complies with the requirements of EN ISO 15197.

Roche Diagnostics hereby declares that the Accu-Chek Mobile blood glucose meter conforms with the basic requirements and other relevant regulations of Directive 1999/5/EC. The conformity declaration may be found at the following Internet address: <http://mobile.accu-chek.com>.

19 System components

The following components belong to the Accu-Chek Mobile meter:

- **Accu-Chek Mobile test cassettes**
Use only these test cassettes when you test with the Accu-Chek Mobile meter.
- **Accu-Chek Mobile control solutions**
Use only these control solutions when you perform control tests with the Accu-Chek Mobile meter and the Accu-Chek Mobil test cassettes.

The following components belong to the Accu-Chek FastClix Mobile lancing device:

- **Accu-Chek FastClix lancet drums**
Use only these lancet drums when you obtain blood with the Accu-Chek FastClix Mobile lancing device.
- **Accu-Chek FastClix Mobile AST cap**
If you wish to use blood from alternate sites (such as the ball of the thumb, forearm, upper arm, calf or thigh) for blood glucose testing, you will need a special AST cap (gray cap with transparent base) to obtain blood with the Accu-Chek FastClix Mobile lancing device.

20 Patents

Accu-Chek Mobile meter

US 5,889,585; US 6,055,060; US 6,379,317

Accu-Chek FastClix Mobile lancing device

21 Customer support and service centre

21.1 Advice and troubleshooting

If you need advice on how to operate the Accu-Chek Mobile meter or the Accu-Chek FastClix Mobile lancing device, if you seem to be obtaining implausible results, or if you suspect that the meter, test cassette, lancing device or lancet drum might be defective, please contact your Roche Diagnostics customer support and service centre. Do not attempt to repair or modify the meter or lancing device yourself. Our staff will help solve any problems you might be experiencing with the meter, test cassette, lancing device or lancet drum from Roche Diagnostics. The addresses of the customer support and service centres are listed in the next section.

21.2 Addresses

22 Alphabetical index

A

acoustic mode 100, 101, 159
 turning on, turning off 102
 After meal (flag) 78, 80
 alternate sites 55
 apple (symbol) 78, 142, 211
 apple, bitten into (symbol) 78, 142, 211
 AST cap 55
 asterisk (symbol) 78, 211
 available tests 31, 32
 viewing 201
 averages 139

B

battery
 changing 202
 disposing 203, 226
 life 202, 228
 removing the protective strip 48
 symbol 77, 211
 type 202, 228

battery compartment 14, 205
 beeper 101
 announcement of results via ~ 162
 during testing 101
 turning off 102
 turning on 102
 with reminders 100
 Before meal (flag) 78, 80
 blood
 applying to the test area 73
 too little applied 222
 volume 21, 228
 blood glucose test 54
 bottle (symbol) 78, 172, 211
 brightness, display 178
 button
 on/off 15, 26
 enter ~ 15, 26
 down 15, 28, 137
 up 15, 29, 201

C

- checking, meter 165
- cleaning
 - lancing device 192
 - meter 182
- concentration table 41, 175
- control solution 165
 - disposing 174
 - validity 177
- control test 83, 165
 - flag 78
 - flagging 83, 171
 - performing 167
 - sources of error 176
- CSV file 151
- customer support and service centre 233

D

- data transfer 144
- date, setting 95
- display 15, 228
 - brightness, setting 128
 - symbols on the ~ 211

- display check 30
 - performing 179
- display format, saved results 134
 - setting 156
- disposal
 - batteries 203, 226
 - meter 225
 - test cassette 197

E

- electromagnetic compatibility 230
- electromagnetic interference, sources of 209
- enter button 15, 26
- error messages 220
 - in acoustic mode 164
- expiry date
 - control solution 177
 - test cassette 46

F

- flagging, result 78
- flags
 - After meal 78, 80
 - Before meal 78, 80
 - control test 78, 83, 171
 - general 78, 80

G

general (flag) 78, 80

H

HI (display) 77, 84, 211

hourglass (symbol) 74

humidity 208, 229

I

infrared window 15, 144

intended use

 lancing device 3

 meter 3

L

lancet drum 17, 57

 changing 61

 disposing 61

 inserting 57

lancet, loading a new 60

lancing device:

 cleaning 192

 components 17

 docking 63

 obtaining blood with the ~ 70

 priming 71

 undockingn 62

light conditions 209

LO (display) 77, 84, 211

M

measuring conditions 207

measuring range 84, 228

measuring time 74, 228

memory 133

 display format 134, 156

memory, results 133

menu

 description 23

 opening 34

 overview 240

meter

- checking 165
- cleaning 182
- components 14
- disposing 226
- storing 207
- turning off 32

- after a test 75, 76

- turning on 30

- opening the memory 134

- performing a test 65, 68

- transferring results 144

- multifunction button, lancing device 17, 71, 72

N

- number of available lancets 17, 60

- number of available tests 31, 201

O

- on/off button 15, 26

overview

- lancing device components 17

- menus 241

- meter components 14

- symbols 211

P

- patents 232

- penetration depth

- indicator 17, 59

- setting 9

- performance evaluation 230

- problems 218

R

- release button

- opening cassette compartment cover 16, 43, 196

- undocking lancing device 16, 62

- reminder 104

- beep tones for ~ 100

- changing 109, 112

- deleting 109, 113

- editing 109

- setting after a test 83

- setting new ~ 106

- turning off 109, 111

- turning on 109, 111

result

- averages 139
- flagging 78
- transferring 144
- viewing in memory 134

S

settings

- acoustic mode 100
 - beeper 100
 - brightness 128
 - date 95
 - default settings 87
 - language 130
 - menu 90
 - overview 87
 - reminders 104
 - beep tones for ~ 100
 - target range 119
 - time 92
 - time format 24
 - tones 100
 - volume 126
- single reminder 115

sources of error

- blood glucose test 85
- control test 176
- transferring results 155

sources of interference

- electromagnetic 209
- light 209

storage conditions 207

symbols 211

- during testing 77

system components 231

T

target range 119

- changing 122, 124
- editing 122
- setting 120
- symbol 77, 119, 211
- turning off 122, 123
- turning on 122, 123

technical data 228

temperature 207, 229

test
 performing 64
 sources of error 85
test area 15
test cassette 16
 changing 193
 disposing 197
 expiry date 46
 inserting first ~ 41
 use-by period 46
 validity 46, 181, 212
test principle 228
tests (test areas) 20
 display of available ~ 31, 32, 201
thermometer (symbol) 77, 211, 216
time format, selecting 98
time, setting 92
tip cover 15, 65, 69
tones, setting 100
Tools menu 178

transferring results 144
 as table (CSV file) 151
 for analysis 149
 sources of error 155
turning off, meter 32
 after a test 75, 76
turning on, meter 30
 opening the memory 134
 performing a test 65, 68
 transferring results 144
type plate 16, 40

U

unit of measurement, result (mmol/l, mg/dl) 5, 40
use-by period, test cassette 46

V

validity, test cassette 46, 212
 displaying 181

23 Menu overview

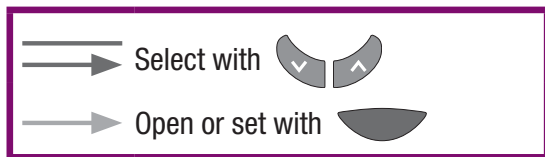
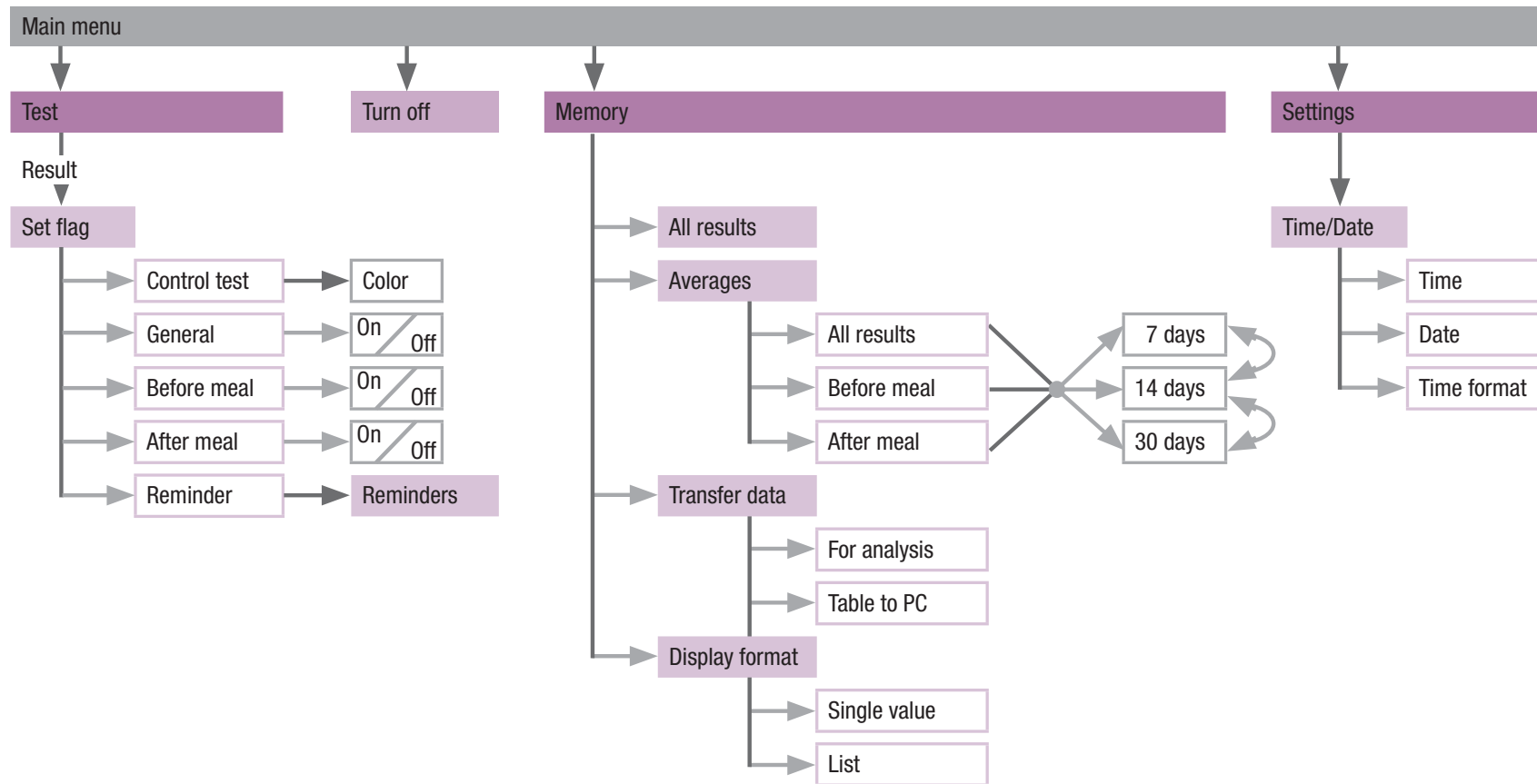

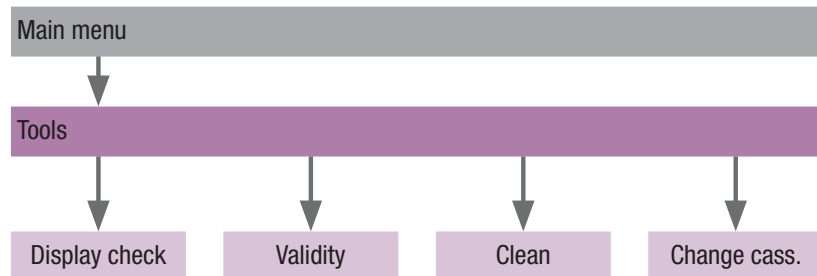
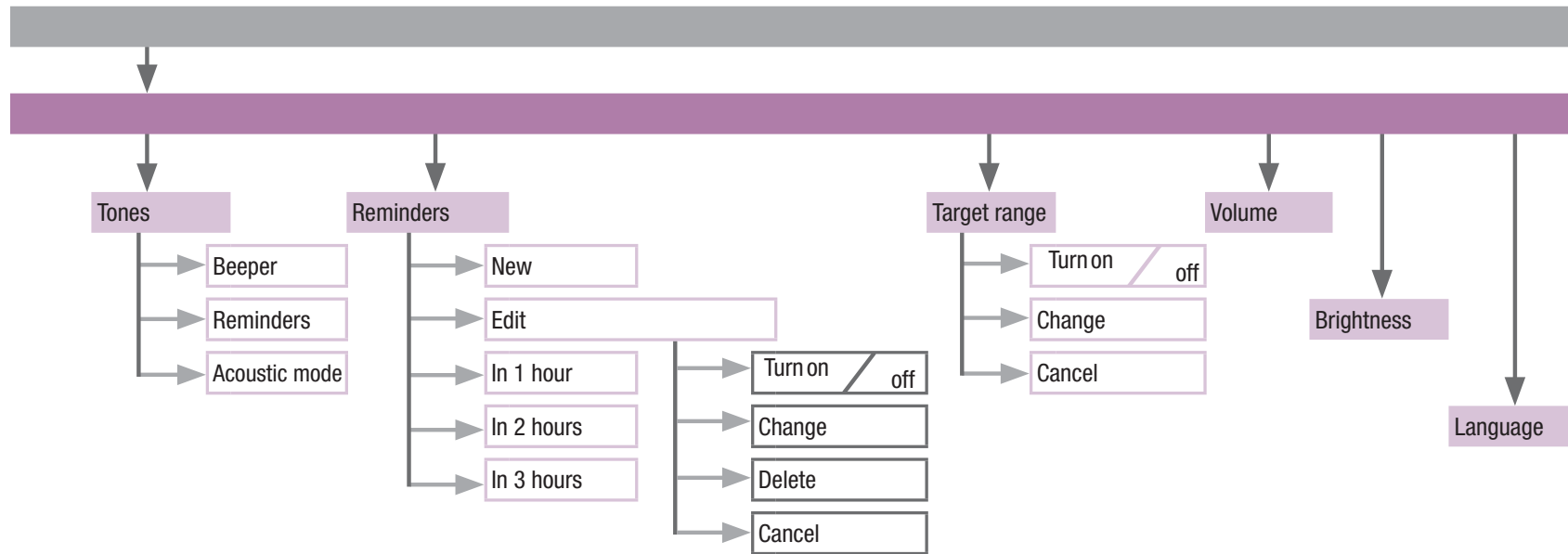



ACCU-CHEK, ACCU-CHEK MOBILE and
FASTCLIX are trademarks of Roche.



Roche Diagnostics GmbH
68298 Mannheim
Germany
www.accu-chek.com