

Airgain Single Band Embedded Antenna Product Datasheet

Profile30S

Model N2430GNS



Coverage. Performance. Smart.

1930 Palomar Point Way, Suite 107
Carlsbad, CA 92008
Tel: +1 760 579 0200
Fax: +1 760 579 0892
Information: info@airgain.com
Sales: sales@airgain.com
Support: support@airgain.com



Coverage. Performance. Smart.

Table of Contents

- 1. Model N2430GNS 2.4GHz Embedded Antenna..... 3
- 2. Features 3
- 3. Specification and Interface 4
- 4. Radiation Patterns 4
- 5. Dimensions 5
- 6. ROHS 6
- 7. Application Guidelines and Recommendations..... 6
 - 7.1. PCB Mounting 6
 - 7.2. Plastic Case loading effects 7
 - 7.3. N2430GNS Reference Board..... 9
- 8. Supporting Documents..... 10
- 9. Revision history 10

Disclaimers

The information in this document is provided in connection with Airgain Antenna products and is proprietary and confidential. Airgain may make changes to at anytime, without notice. *Please verify with Airgain before finalizing a product design.*

1. Model N2430GNS 2.4GHz Embedded Antenna

Using Airgain's patented technology, the Model N2430GNS antenna provides a high gain, on-board antenna solution for Wi-Fi and ISM band applications. As embedded antenna solutions become the focus of next generation wireless product design, the N2430GNS provides the flexibility of an embedded antenna without sacrificing performance. The N2430GNS 2.4GHz antenna was designed to accommodate most WLAN access point applications, such as routers and gateways, with a low-cost, low profile, and enhanced performance PCB component design.

2. Features

The Model N2430GNS is defined by the following features:

- IEEE 802.11 b/g/n compatible
- PCB mounting, low profile design
- 5dBi @2.44 GHz, Peak Gain
- Low Cost, High performance
- Reliable Through-Hole mounting



Figure 1
Model N2430GNS Antenna

3. Specification and Interface

Standard	IEEE 802.11n and 802.11 b/g
Frequency Range	2.4 to 2.49 GHz
Peak Gain	5dBi @2.44 GHz
VSWR	2:1
Feed Impedance	50 Ohms
Power Handling	30 dBm
Interface	Two, 1 mm x 2.4 mm, Through hole pins for 50 ohm microstripline trace
Antenna Dimensions (LxWxH)	34.0 x 5 x 12.2 (mm)
Weight	1.5 g (0.053 oz)
Temperature	Operating: -40° to +75°C Storage: -40° to +85°C
Humidity	0 to 95%, non-condensing

4. Radiation Patterns

Data shown is for one N2430GNS mounted on a Model N2430GNS Reference PCB and covered with a 2.5mm thick ABS plastic sheet.

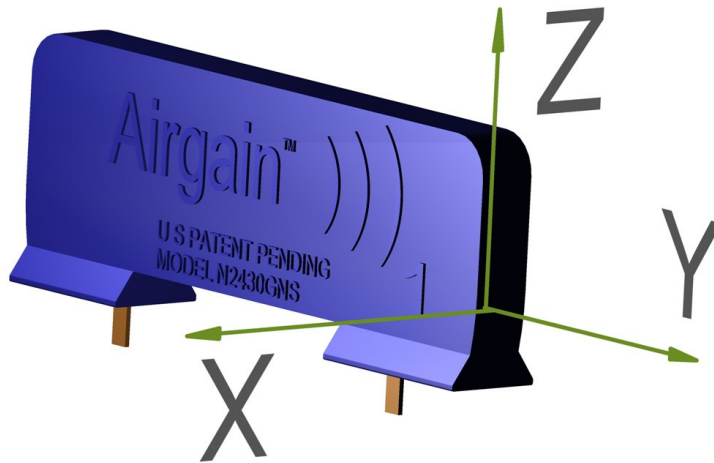

Figure 2

Model N2430GNS Antenna axis orientation for radiation pattern

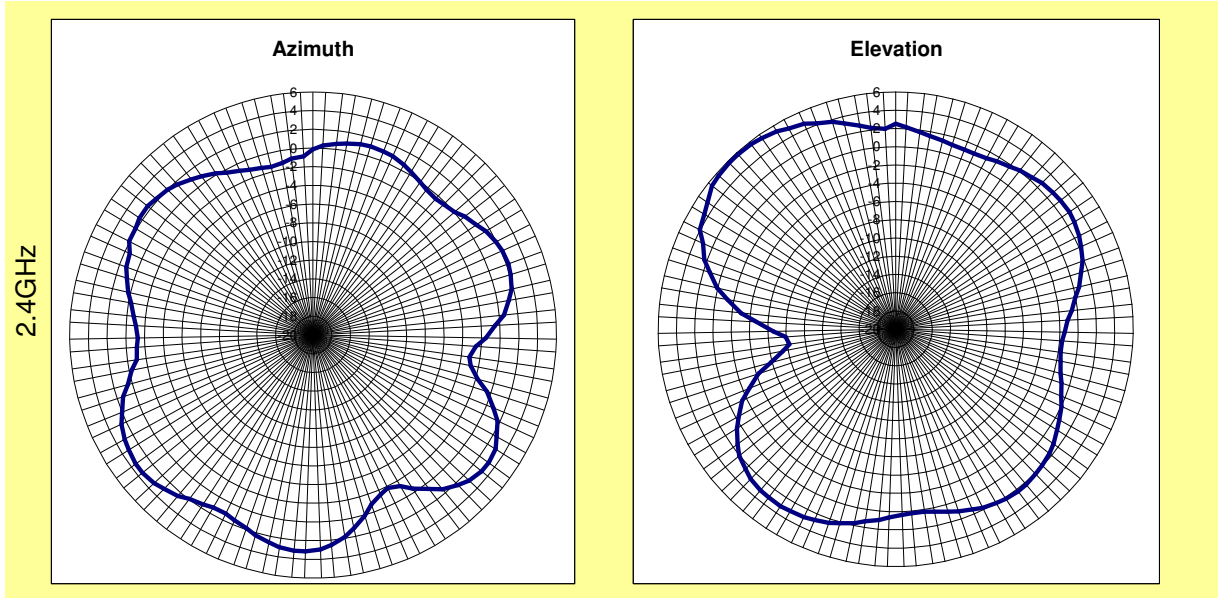

Figure 3
2.4GHz Radiation Patterns

5. Dimensions

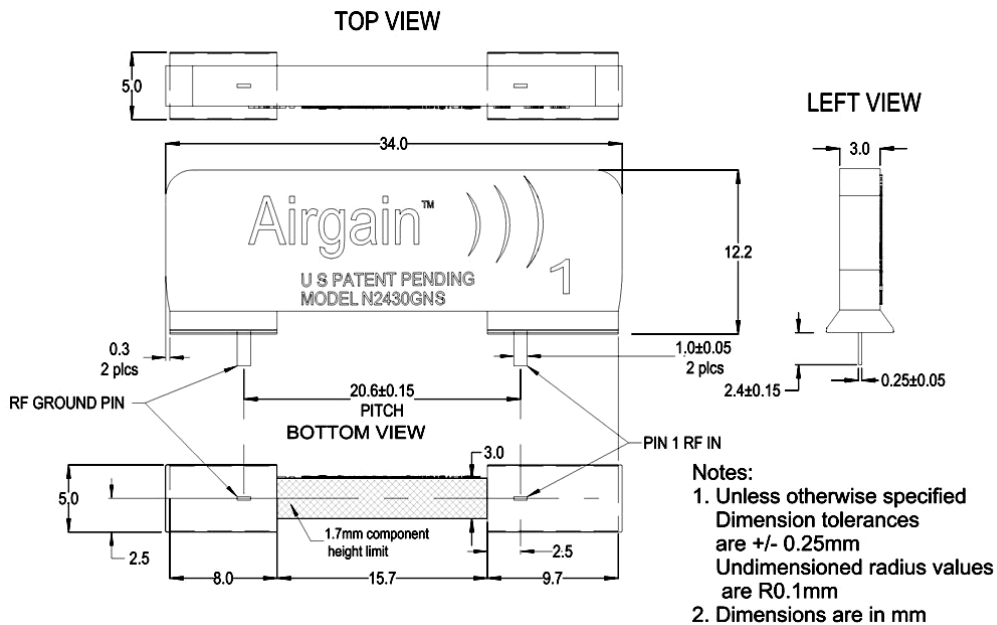

Figure 3
Model N2430GNS Dimensions

6. ROHS

Model N2430GNS Antennas are RoHS compliant.

7. Application Guidelines and Recommendations

The Model N2430GNS antenna incorporates a stable support footprint and through hole pin connections, simplifying use in new PCB designs. Airgain has developed guidelines that should be followed to achieve the best performance from the Model N2430GNS. These recommendations apply to both IEEE 802.11a/b/g and n applications. The Model N2430GNS Reference Board PCB also implements these recommendations. This evaluation tool is available through Airgain sales representatives.

7.1. PCB Mounting

The recommended layout of a design implementation is shown in Figure 6. N2430GNS performance is fairly independent of its location on the PCB, provided it is positioned close to a PCB edge. Place the N2430GNS parallel to, and centered 3.0 mm away from the edge of the PCB. Performance is improved if Pin 1 is placed no closer than 15 mm from the nearest orthogonal edge of the PCB. A larger distance between Pin 1 and the orthogonal edge of the PCB is often better. When Pin 2 is the closest pin to the nearest orthogonal edge of the PCB, Pin 1 should be placed no closer than 35 mm from that same orthogonal edge of the PCB. Performance tests have had the N2430GNS mounted onto a 1 mm, 4 layer, FR4 PCB. Pin 1 through hole is designed to be 50 ohms. Pin 2 through hole is a direct connection to RF ground (recommended).

Airgain also suggests a 10 mm keepout area alongside the M2430GND when placing components taller than 2.5 mm on the PCB.

The important mounting constraints on a PCB are shown below

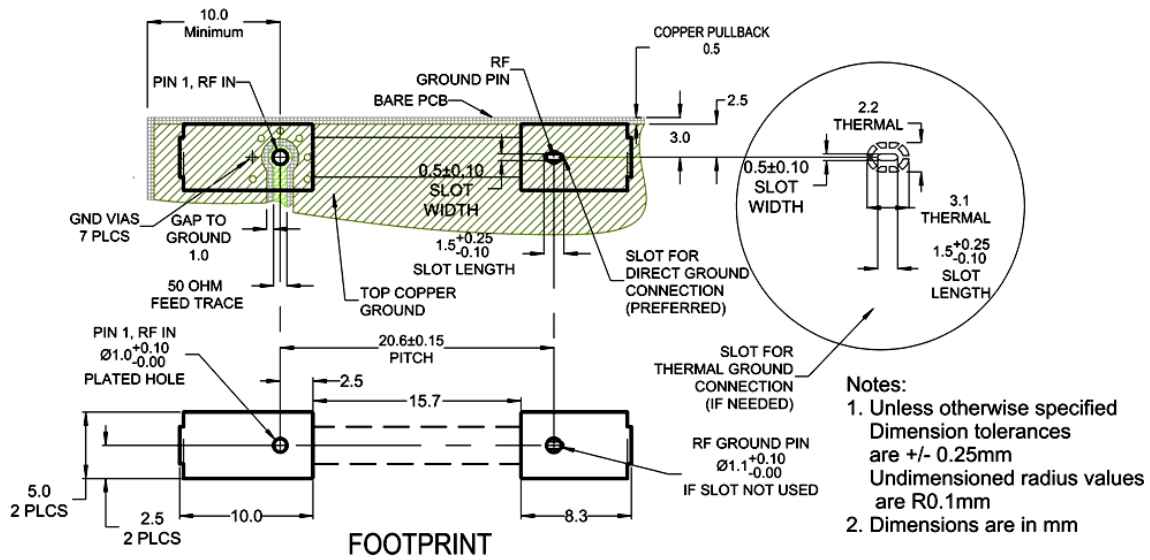

Figure 6
Top View of a Design Layout

Notes:

- Keep a minimum 10 mm distance from the antenna feeding point to the orthogonal edge of the PCB.
- Keep 2.5 mm distance from the Model N2430GNS centerline to the edge of the copper layer parallel to the Model N2430GNS.

7.2. Plastic Case loading effects

The antenna is mildly affected (loaded) by nearby plastic case features.

A 1.5 mm space from the antenna element to the case top is recommended to optimize performance.

A 5 mm minimum distance from the antenna element to any case walls or other features is recommended.

**SIDE VIEW:
RECOMMENDATIONS FOR CASE TOP LOADING N2430GNS.
AND CONSIDERATIONS WHEN PLACING
N2430GNS NEAR PLASTIC CASE FEATURES**

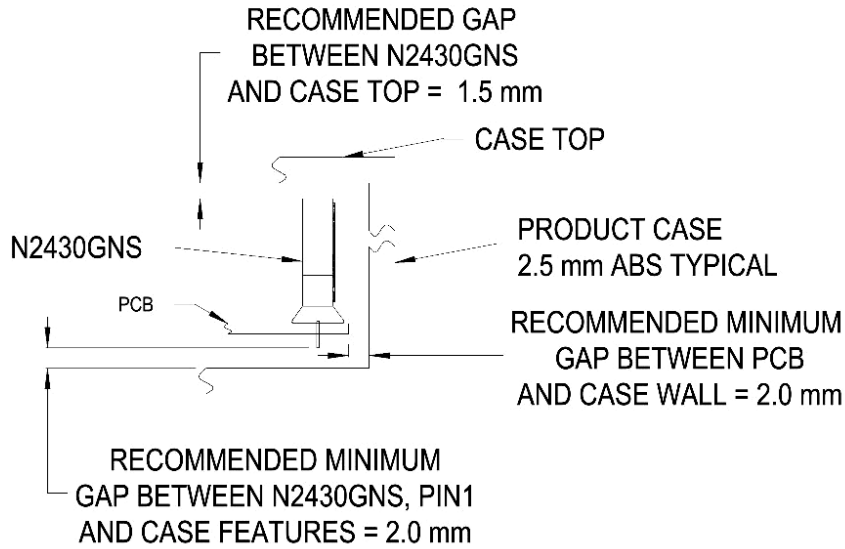

Figure 7

Side view of case top loading considerations when implementing a N2430GNS based design

7.3. N2430GNS Reference Board

The Model N2430GNS Reference Board PCB with 3 antenna mounting locations, also implements the placement recommendations from the previous section. An exception being the 3 antenna feeds, which are 100 mm micro coax cables with U.FL compatible plug terminations. The Model N2430GNS Reference Board is designed to demonstrate antenna performance in IEEE 802.11a/b/g and n applications up to 3 x 3 MIMO configurations.

This 110 mm x 110 mm evaluation tool is available through Airgain sales representatives.

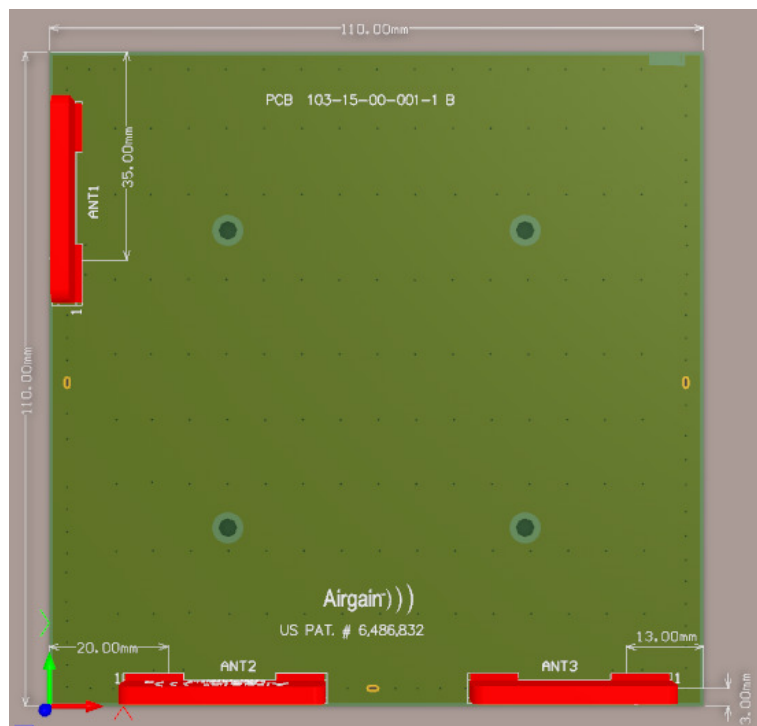

Figure 8

110 mm x 110 mm, 103-15-00-001-1_B Model N2430GNS Reference Board

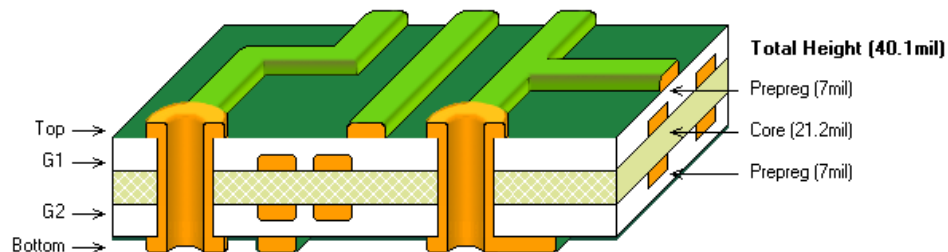

Figure 9

Recommended layer stack-up

8. Supporting Documents

The following design documents are used as references for design implementation of the Airgain Model N2430GNS antenna product: Contact your Airgain representative for more information

Dimension Drawing	198-07-00-001A N2430GNS Top Level.pdf
Drawing of the Evaluation Board	103-07-00-001-1_A_ASSY.PDF

9. Revision history

Revision	Date	Note
198-02-00-001-1 Rev A	December 2, 2010	Release



1930 Palomar Point Way, Suite 107
Carlsbad, CA 92008
U.S.A.

March 30, 2011

To Whom It May Concern,

Airgain internal antenna (N2430GNS) is designed to be installed within an enclosure. It should not come into direct contact with human beings. Henceforth, it does not fall within the control of PFOS and PAHS test requirements.

Regards,

A handwritten signature in black ink, appearing to read "Robin Poei".

Robin Poei
Airgain, Inc.

