

FCC Radio Test Report

FCC ID: VW3FAST286

This report concerns: Original Grant

Project No. : 2007C003
Equipment : Smart Wi-Fi extender
Brand Name : SAGEMCOM
Test Model : F286 US
Series Model : N/A
Applicant : SAGEMCOM BROADBAND SAS
Address : 250 Route de l' Empereur - 92848 RUEIL MALMAISONCEDEX- FRANCE
Manufacturer : SAGEMCOM BROADBAND SAS
Address : 250 Route de l' Empereur - 92848 RUEIL MALMAISONCEDEX- FRANCE
Date of Receipt : Jul. 01, 2020
Date of Test : Jul. 02, 2020 ~ Aug. 03, 2020
Issued Date : Jun. 02, 2021
Report Version : R00
Test Sample : Engineering Sample No.: DG20200701165 for conducted,
DG20200701166 for radiated.
Standard(s) : FCC Part15, Subpart E(15.407)
ANSI C63.10-2013
FCC KDB 789033 D02 General UNII Test Procedures New Rules v02r01
FCC KDB 662911 D01 Multiple Transmitter Output v02r01

The above equipment has been tested and found compliance with the requirement of the relative standards by BTL Inc.

Chay Cai

Prepared by : Chay Cai

Ethan Ma

Approved by : Ethan Ma



Certificate #5123.02

Add: No.3, Jinshagang 1st Road, Shixia, Dalang Town, Dongguan, Guangdong, China.

Tel: +86-769-8318-3000

Web: www.newbtl.com

Declaration

BTL represents to the client that testing is done in accordance with standard procedures as applicable and that test instruments used has been calibrated with standards traceable to international standard(s) and/or national standard(s).

BTL's reports apply only to the specific samples tested under conditions. It is manufacture's responsibility to ensure that additional production units of this model are manufactured with the identical electrical and mechanical components. **BTL** shall have no liability for any declarations, inferences or generalizations drawn by the client or others from **BTL** issued reports.

The report must not be used by the client to claim product certification, approval, or endorsement by NVLAP, NIST, A2LA, or any agency of the U.S. Government.

This report is the confidential property of the client. As a mutual protection to the clients, the public and ourselves, the test report shall not be reproduced, except in full, without our written approval.

BTL's laboratory quality assurance procedures are in compliance with the **ISO/IEC 17025** requirements, and accredited by the conformity assessment authorities listed in this test report.

BTL is not responsible for the sampling stage, so the results only apply to the sample as received.

The information, data and test plan are provided by manufacturer which may affect the validity of results, so it is manufacturer's responsibility to ensure that the apparatus meets the essential requirements of applied standards and in all the possible configurations as representative of its intended use.

Limitation

For the use of the authority's logo is limited unless the Test Standard(s)/Scope(s)/Item(s) mentioned in this test report is (are) included in the conformity assessment authorities acceptance respective.

Please note that the measurement uncertainty is provided for informational purpose only and are not use in determining the Pass/Fail results.

Table of Contents	Page
REPORT ISSUED HISTORY	6
1 . SUMMARY OF TEST RESULTS	7
1.1 TEST FACILITY	8
1.2 MEASUREMENT UNCERTAINTY	8
1.3 TEST ENVIRONMENT CONDITIONS	9
2 . GENERAL INFORMATION	10
2.1 GENERAL DESCRIPTION OF EUT	10
2.2 TEST MODES	14
2.3 PARAMETERS OF TEST SOFTWARE	19
2.4 DUTY CYCLE	23
2.5 BLOCK DIAGRAM SHOWING THE CONFIGURATION OF SYSTEM TESTED	25
2.6 SUPPORT UNITS	25
3 . AC POWER LINE CONDUCTED EMISSIONS TEST	26
3.1 LIMIT	26
3.2 TEST PROCEDURE	26
3.3 DEVIATION FROM TEST STANDARD	26
3.4 TEST SETUP	27
3.5 EUT OPERATION CONDITIONS	27
3.6 TEST RESULTS	27
4 . RADIATED EMISSIONS TEST	28
4.1 LIMIT	28
4.2 TEST PROCEDURE	29
4.3 DEVIATION FROM TEST STANDARD	29
4.4 TEST SETUP	30
4.5 EUT OPERATION CONDITIONS	31
4.6 TEST RESULTS - 9 KHZ to 30 MHZ	31
4.7 TEST RESULTS - 30 MHz TO 1000 MHz	31
4.8 TEST RESULTS - ABOVE 1000 MHz	31
5 . BANDWIDTH TEST	32
5.1 LIMIT	32
5.2 TEST PROCEDURE	32
5.3 DEVIATION FROM STANDARD	32

Table of Contents	Page
5.4 TEST SETUP	33
5.5 EUT OPERATION CONDITIONS	33
5.6 TEST RESULTS	33
6 . MAXIMUM OUTPUT POWER TEST	34
6.1 LIMIT	34
6.2 TEST PROCEDURE	34
6.3 DEVIATION FROM STANDARD	34
6.4 TEST SETUP	34
6.5 EUT OPERATION CONDITIONS	34
6.6 TEST RESULTS	34
7 . POWER SPECTRAL DENSITY TEST	35
7.1 LIMIT	35
7.2 TEST PROCEDURE	35
7.3 DEVIATION FROM STANDARD	36
7.4 TEST SETUP	36
7.5 EUT OPERATION CONDITIONS	36
7.6 TEST RESULTS	36
8 . FREQUENCY STABILITY MEASUREMENT	37
8.1 LIMIT	37
8.2 TEST PROCEDURE	37
8.3 DEVIATION FROM STANDARD	37
8.4 TEST SETUP	37
8.5 EUT OPERATION CONDITIONS	37
8.6 TEST RESULTS	37
9 . MEASUREMENT INSTRUMENTS LIST	38
10 . EUT TEST PHOTOS	40
APPENDIX A - AC POWER LINE CONDUCTED EMISSIONS	44
APPENDIX B - RADIATED EMISSION - 9 KHZ TO 30 MHZ	47
APPENDIX C - RADIATED EMISSION - 30 MHZ TO 1 GHZ	52
APPENDIX D - RADIATED EMISSION - ABOVE 1000 MHZ	55
APPENDIX E - BANDWIDTH	208
APPENDIX F - MAXIMUM OUTPUT POWER	225

Table of Contents**Page****APPENDIX G - POWER SPECTRAL DENSITY****270****APPENDIX H - FREQUENCY STABILITY****302**

REPORT ISSUED HISTORY

Report Version	Description	Issued Date
R00	Original Issue.	Jun. 02, 2021

1. SUMMARY OF TEST RESULTS

Test procedures according to the technical standard(s):

FCC Part15, Subpart E(15.407)				
Standard(s) Section	Test Item	Test Result	Judgement	Remark
15.207 15.407(b)	AC Power Line Conducted Emissions	APPENDIX A	PASS	-----
15.407(b) 15.205(a) 15.209(a)	Radiated Emissions	APPENDIX B APPENDIX C APPENDIX D	PASS	-----
15.407(a) 15.407(e)	Spectrum Bandwidth	APPENDIX E	PASS	-----
15.407(a)	Maximum Output Power	APPENDIX F	PASS	-----
15.407(a)	Power Spectral Density	APPENDIX G	PASS	-----
15.407(g)	Frequency Stability	APPENDIX H	PASS	-----
15.203	Antenna Requirements	-----	PASS	NOTE (2)
15.407(c)	Automatically Discontinue Transmission	-----	PASS	NOTE (3)

Note:

- (1) "N/A" denotes test is not applicable in this test report.
- (2) The device what use a permanently attached antenna were considered sufficient to comply with the provisions of 15.203.
- (3) During no any information transmission, the EUT can automatically discontinue transmission and become standby mode for power saving. the EUT can detect the controlling signal of ACK message transmitting from remote device and verify whether it shall resend or discontinue transmission.
- (4) For UNII-1 this device was functioned as a
 Access point device Client device

1.1 TEST FACILITY

The test facilities used to collect the test data in this report is at the location of No.3,Jinshagang 1st Road, Shixia, Dalang Town, Dongguan, Guangdong, China.

BTL's Test Firm Registration Number for FCC: 357015

BTL's Designation Number for FCC: CN1240

1.2 MEASUREMENT UNCERTAINTY

ISO/IEC 17025 requires that an estimate of the measurement uncertainties associated with the emissions test results be included in the report. The measurement uncertainties given below are based on a 95% confidence level (based on a coverage factor (k=2))

The BTL measurement uncertainty as below table:

A. AC power line conducted emissions test:

Test Site	Method	Measurement Frequency Range	U, (dB)
DG-C02	CISPR	150kHz ~ 30MHz	2.60

B. Radiated emissions test:

Test Site	Method	Measurement Frequency Range	Ant. H / V	U, (dB)
DG-CB03	CISPR	9kHz ~ 30MHz	V	3.79
		9kHz ~ 30MHz	H	3.57
		30MHz ~ 200MHz	V	4.88
		30MHz ~ 200MHz	H	4.14
		200MHz ~ 1,000MHz	V	4.62
		200MHz ~ 1,000MHz	H	4.80
		1GHz ~ 6GHz	-	4.58
		6GHz ~ 18GHz	-	5.18
		18GHz ~ 26.5GHz	-	3.62
		26.5GHz ~ 40GHz	-	4.00

C. Other Measurement:

Parameter	Uncertainty
Spectrum Bandwidth	±3.8 %
Maximum Output Power	±0.95 dB
Power Spectral Density	±0.86 dB
Frequency Stability	±0.16 dB
Temperature	±0.08 °C
Time	±0.58 %
Supply voltages	±0.3 %

Note: Unless specifically mentioned, the uncertainty of measurement has not been taken into account to declare the compliance or non-compliance to the specification.

1.3 TEST ENVIRONMENT CONDITIONS

Test Item	Temperature	Humidity	Test Voltage	Tested By
AC Power Line Conducted Emissions	25°C	53%	AC 120V/60Hz	Sheldon Ou
Radiated Emissions-9K-30MHz	25°C	60%	AC 120V/60Hz	Sheldon Ou
Radiated Emissions-30 MHz to 1GHz	22°C	54%	AC 120V/60Hz	Sheldon Ou
Radiated Emissions-Above 1000 MHz	22°C	54%	AC 120V/60Hz	Sheldon Ou
Spectrum Bandwidth	24°C	62%	DC 12V	Hayden Chen
Maximum Output Power	24°C	62%	DC 12V	Laughing Zhang
Power Spectral Density	24°C	62%	DC 12V	Hayden Chen
Frequency Stability	Normal & Extreme	62%	Normal & Extreme	Hayden Chen

2. GENERAL INFORMATION

2.1 GENERAL DESCRIPTION OF EUT

Equipment	Smart Wi-Fi extender
Brand Name	SAGEMCOM
Test Model	F286 US
Series Model	N/A
Model Difference(s)	N/A
Hardware Version	SagemcomFast286-01
Software Version	10.10.131.34
Power Source	DC voltage supplied from AC adapter. 1# Manufacturer / Model: MOSO / MSG-V1500NR120-01810-US 2# Manufacturer / Model: HONOR / ADS-18FQA-12 12018EPCU-L
Power Rating	I/P: 100-127V~ 50/60Hz 0.7A max. O/P: 12.0V == 1.5A
Operation Frequency Bands	UNII-1: 5150 MHz~5250 MHz UNII-2A: 5250 MHz~5350 MHz UNII-2C: 5470 MHz~5725 MHz UNII-3: 5725 MHz~5850 MHz
Modulation Type	OFDM
Bit Rate of Transmitter	Up to 1733.2 Mbps
Maximum Output Power _ UNII-1 Non Beamforming	IEEE 802.11a: 27.44 dBm (0.5546 W) IEEE 802.11n (HT20): 28.67 dBm (0.7362 W) IEEE 802.11n (HT40): 26.72 dBm (0.4699 W) IEEE 802.11ac (VHT20): 28.98 dBm (0.7907 W) IEEE 802.11ac (VHT40): 27.06 dBm (0.5082 W) IEEE 802.11ac (VHT80): 23.87 dBm (0.2438 W)
Maximum Output Power _ UNII-2A Non Beamforming	IEEE 802.11a: 22.89 dBm (0.1945 W) IEEE 802.11n (HT20): 22.37 dBm (0.1726 W) IEEE 802.11n (HT40): 23.91 dBm (0.2460 W) IEEE 802.11ac (VHT20): 22.66 dBm (0.1845 W) IEEE 802.11ac (VHT40): 23.96 dBm (0.2489 W) IEEE 802.11ac (VHT80): 23.81 dBm (0.2404 W)
Maximum Output Power _ UNII-2C Non Beamforming	IEEE 802.11a: 23.69 dBm (0.2339 W) IEEE 802.11n (HT20): 22.53 dBm (0.1791 W) IEEE 802.11n (HT40): 23.91 dBm (0.2460 W) IEEE 802.11ac (VHT20): 22.70 dBm (0.1862 W) IEEE 802.11ac (VHT40): 23.95 dBm (0.2483 W) IEEE 802.11ac (VHT80): 23.90 dBm (0.2455 W)
Maximum Output Power _ UNII-3 Non Beamforming	IEEE 802.11a: 27.07 dBm (0.5093 W) IEEE 802.11n (HT20): 29.50 dBm (0.8913 W) IEEE 802.11n (HT40): 29.71 dBm (0.9354 W) IEEE 802.11ac (VHT20): 29.61 dBm (0.9141 W) IEEE 802.11ac (VHT40): 29.75 dBm (0.9441 W) IEEE 802.11ac (VHT80): 26.95 dBm (0.4955 W)

Maximum Output Power _UNII-1 Beamforming	IEEE 802.11n (HT20): 28.38 dBm (0.6887 W) IEEE 802.11n (HT40): 26.42 dBm (0.4385 W) IEEE 802.11ac (VHT20): 28.59 dBm (0.7228 W) IEEE 802.11ac (VHT40): 26.76 dBm (0.4742 W) IEEE 802.11ac (VHT80): 23.53 dBm (0.2254 W)
Maximum Output Power _UNII-2A Beamforming	IEEE 802.11n (HT20): 22.06 dBm (0.1607 W) IEEE 802.11n (HT40): 23.65 dBm (0.2317 W) IEEE 802.11ac (VHT20): 22.37 dBm (0.1726 W) IEEE 802.11ac (VHT40): 23.70 dBm (0.2344 W) IEEE 802.11ac (VHT80): 23.49 dBm (0.2234 W)
Maximum Output Power _UNII-2C Beamforming	IEEE 802.11n (HT20): 22.24 dBm (0.1675 W) IEEE 802.11n (HT40): 23.76 dBm (0.2377 W) IEEE 802.11ac (VHT20): 22.38 dBm (0.1730 W) IEEE 802.11ac (VHT40): 23.75 dBm (0.2371 W) IEEE 802.11ac (VHT80): 23.61 dBm (0.2296 W)
Maximum Output Power _UNII-3 Beamforming	IEEE 802.11n (HT20): 29.15 dBm (0.8222 W) IEEE 802.11n (HT40): 29.40 dBm (0.8710 W) IEEE 802.11ac (VHT20): 29.34 dBm (0.8590 W) IEEE 802.11ac (VHT40): 29.46 dBm (0.8831 W) IEEE 802.11ac (VHT80): 26.64 dBm (0.4613 W)

Note:

1. For a more detailed features description, please refer to the manufacturer's specifications or the user's manual.

2. Channel List:

IEEE 802.11a IEEE 802.11n (HT20) IEEE 802.11ac (VHT20)		IEEE 802.11n (HT40) IEEE 802.11ac (VHT40)		IEEE 802.11ac (VHT80)	
UNII-1		UNII-1		UNII-1	
Channel	Frequency (MHz)	Channel	Frequency (MHz)	Channel	Frequency (MHz)
36	5180	38	5190	42	5210
40	5200	46	5230		
44	5220				
48	5240				

IEEE 802.11a IEEE 802.11n (HT20) IEEE 802.11ac (VHT20)		IEEE 802.11n (HT40) IEEE 802.11ac (VHT40)		IEEE 802.11ac (VHT80)	
UNII-2A		UNII-2A		UNII-2A	
Channel	Frequency (MHz)	Channel	Frequency (MHz)	Channel	Frequency (MHz)
52	5260	54	5270	58	5290
56	5280	62	5310		
60	5300				
64	5320				

IEEE 802.11a IEEE 802.11n (HT20) IEEE 802.11ac (VHT20)		IEEE 802.11n (HT40) IEEE 802.11ac (VHT40)		IEEE 802.11ac (VHT80)	
UNII-2C		UNII-2C		UNII-2C	
Channel	Frequency (MHz)	Channel	Frequency (MHz)	Channel	Frequency (MHz)
100	5500	102	5510	106	5530
104	5520	110	5550	122	5610
108	5540	118	5590		
112	5560	126	5630		
116	5580	134	5670		
120	5600				
124	5620				
128	5640				
132	5660				
136	5680				
140	5700				

IEEE 802.11a IEEE 802.11n (HT20) IEEE 802.11ac (VHT20)		IEEE 802.11n (HT40) IEEE 802.11ac (VHT40)		IEEE 802.11ac (VHT80)	
UNII-3		UNII-3		UNII-3	
Channel	Frequency (MHz)	Channel	Frequency (MHz)	Channel	Frequency (MHz)
149	5745	151	5755	155	5775
153	5765	159	5795		
157	5785				
161	5805				
165	5825				

3. Antenna Specification:

Ant.	Brand	Model Name	Antenna Type	Connector	Gain (dBi)
1	N/A	N/A	Internal	N/A	3
2	N/A	N/A	Internal	N/A	3
3	N/A	N/A	Internal	N/A	3
4	N/A	N/A	Internal	N/A	3

Note:

- 1) This EUT supports MIMO 4X4, and all antennas have the same gain, any transmit signals are uncorrelated with each other, so the Directional Gain=Antenna Gain=3.
- 2) Beamforming Gain: 3 dB. So the Directional gain=3+3=6.

4. Table for Antenna Configuration:
For Non Beamforming:

Operating Mode / TX Mode	1TX	4TX
IEEE 802.11a	V (Ant. 1)	-
IEEE 802.11n (HT20)	-	V (Ant. 1 + Ant. 2 + Ant. 3 + Ant. 4)
IEEE 802.11n (HT40)	-	V (Ant. 1 + Ant. 2 + Ant. 3 + Ant. 4)
IEEE 802.11ac (VHT20)	-	V (Ant. 1 + Ant. 2 + Ant. 3 + Ant. 4)
IEEE 802.11ac (VHT40)	-	V (Ant. 1 + Ant. 2 + Ant. 3 + Ant. 4)
IEEE 802.11ac (VHT80)	-	V (Ant. 1 + Ant. 2 + Ant. 3 + Ant. 4)

For Beamforming:

Operating Mode / TX Mode	4TX
IEEE 802.11n (HT20)	V (Ant. 1 + Ant. 2 + Ant. 3 + Ant. 4)
IEEE 802.11n (HT40)	V (Ant. 1 + Ant. 2 + Ant. 3 + Ant. 4)
IEEE 802.11ac (VHT20)	V (Ant. 1 + Ant. 2 + Ant. 3 + Ant. 4)
IEEE 802.11ac (VHT40)	V (Ant. 1 + Ant. 2 + Ant. 3 + Ant. 4)
IEEE 802.11ac (VHT80)	V (Ant. 1 + Ant. 2 + Ant. 3 + Ant. 4)

2.2 TEST MODES

The test system was pre-tested based on the consideration of all possible combinations of EUT operation mode.

Pretest Mode	Description
Mode 1	TX A Mode / CH36, CH40, CH48 (UNII-1)
Mode 2	TX N (HT20) Mode / CH36, CH40, CH48 (UNII-1)
Mode 3	TX N (HT40) Mode / CH38, CH46 (UNII-1)
Mode 4	TX AC (VHT20) Mode / CH36, CH40, CH48 (UNII-1)
Mode 5	TX AC (VHT40) Mode / CH38, CH46 (UNII-1)
Mode 6	TX AC (VHT80) Mode / CH42 (UNII-1)
Mode 7	TX A Mode / CH52, CH60, CH64 (UNII-2A)
Mode 8	TX N (HT20) Mode / CH52, CH60, CH64 (UNII-2A)
Mode 9	TX N (HT40) Mode / CH54, CH62 (UNII-2A)
Mode 10	TX AC (VHT20) Mode / CH52, CH60, CH64 (UNII-2A)
Mode 11	TX AC (VHT40) Mode / CH54, CH62 (UNII-2A)
Mode 12	TX AC (VHT80) Mode / CH58 (UNII-2A)
Mode 13	TX A Mode / CH100, CH116, CH140 (UNII-2C)
Mode 14	TX N (HT20) Mode / CH100, CH116, CH140 (UNII-2C)
Mode 15	TX N (HT40) Mode / CH102, CH110, CH134 (UNII-2C)
Mode 16	TX AC (VHT20) Mode / CH100, CH116, CH140 (UNII-2C)
Mode 17	TX AC (VHT40) Mode / CH102, CH110, CH134 (UNII-2C)
Mode 18	TX AC (VHT80) Mode / CH106, CH122 (UNII-2C)
Mode 19	TX A Mode / CH149,CH157,CH165 (UNII-3)
Mode 20	TX N (HT20) Mode / CH149,CH157,CH165 (UNII-3)
Mode 21	TX N (HT40) Mode / CH151,CH159 (UNII-3)
Mode 22	TX AC (VHT20) Mode / CH149,CH157,CH165 (UNII-3)
Mode 23	TX AC (VHT40) Mode / CH151,CH159 (UNII-3)
Mode 24	TX AC (VHT80) Mode / CH155 (UNII-3)
Mode 25	TX AC(VHT40) Mode / CH159 (UNII-3)

Following mode(s) was (were) found to be the worst case(s) and selected for the final test.

AC power line conducted emissions test	
Final Test Mode	Description
Mode 25	TX AC(VHT40) Mode / CH159 (UNII-3)

Radiated Emissions test - Below 1GHz	
Final Test Mode	Description
Mode 25	TX AC(VHT40) Mode / CH159 (UNII-3)

Radiated emissions test - Above 1GHz	
Final Test Mode	Description
Mode 1	TX A Mode / CH36, CH40, CH48 (UNII-1)
Mode 4	TX AC (VHT20) Mode / CH36, CH40, CH48 (UNII-1)
Mode 5	TX AC (VHT40) Mode / CH38, CH46 (UNII-1)
Mode 6	TX AC (VHT80) Mode / CH42 (UNII-1)
Mode 7	TX A Mode / CH52, CH60, CH64 (UNII-2A)
Mode 10	TX AC (VHT20) Mode / CH52, CH60, CH64 (UNII-2A)
Mode 11	TX AC (VHT40) Mode / CH54, CH62 (UNII-2A)
Mode 12	TX AC (VHT80) Mode / CH58 (UNII-2A)
Mode 13	TX A Mode / CH100, CH116, CH140 (UNII-2C)
Mode 16	TX AC (VHT20) Mode / CH100, CH116, CH140 (UNII-2C)
Mode 17	TX AC (VHT40) Mode / CH102, CH110, CH134 (UNII-2C)
Mode 18	TX AC (VHT80) Mode / CH106, CH122 (UNII-2C)
Mode 19	TX A Mode / CH149,CH157,CH165 (UNII-3)
Mode 22	TX AC (VHT20) Mode / CH149,CH157,CH165 (UNII-3)
Mode 23	TX AC (VHT40) Mode / CH151,CH159 (UNII-3)
Mode 24	TX AC (VHT80) Mode / CH155 (UNII-3)

Maximum Output Power - Non Beamforming	
Final Test Mode	Description
Mode 1	TX A Mode / CH36, CH40, CH48 (UNII-1)
Mode 2	TX N (HT20) Mode / CH36, CH40, CH48 (UNII-1)
Mode 3	TX N (HT40) Mode / CH38, CH46 (UNII-1)
Mode 4	TX AC (VHT20) Mode / CH36, CH40, CH48 (UNII-1)
Mode 5	TX AC (VHT40) Mode / CH38, CH46 (UNII-1)
Mode 6	TX AC (VHT80) Mode / CH42 (UNII-1)
Mode 7	TX A Mode / CH52, CH60, CH64 (UNII-2A)
Mode 8	TX N (HT20) Mode / CH52, CH60, CH64 (UNII-2A)
Mode 9	TX N (HT40) Mode / CH54, CH62 (UNII-2A)
Mode 10	TX AC (VHT20) Mode / CH52, CH60, CH64 (UNII-2A)
Mode 11	TX AC (VHT40) Mode / CH54, CH62 (UNII-2A)
Mode 12	TX AC (VHT80) Mode / CH58 (UNII-2A)
Mode 13	TX A Mode / CH100, CH116, CH140 (UNII-2C)
Mode 14	TX N (HT20) Mode / CH100, CH116, CH140 (UNII-2C)
Mode 15	TX N (HT40) Mode / CH102, CH110, CH134 (UNII-2C)
Mode 16	TX AC (VHT20) Mode / CH100, CH116, CH140 (UNII-2C)
Mode 17	TX AC (VHT40) Mode / CH102, CH110, CH134 (UNII-2C)
Mode 18	TX AC (VHT80) Mode / CH106, CH122 (UNII-2C)
Mode 19	TX A Mode / CH149,CH157,CH165 (UNII-3)
Mode 20	TX N (HT20) Mode / CH149,CH157,CH165 (UNII-3)
Mode 21	TX N (HT40) Mode / CH151,CH159 (UNII-3)
Mode 22	TX AC (VHT20) Mode / CH149,CH157,CH165 (UNII-3)
Mode 23	TX AC (VHT40) Mode / CH151,CH159 (UNII-3)
Mode 24	TX AC (VHT80) Mode / CH155 (UNII-3)

Maximum Output Power - Beamforming	
Final Test Mode	Description
Mode 2	TX N (HT20) Mode / CH36, CH40, CH48 (UNII-1)
Mode 3	TX N (HT40) Mode / CH38, CH46 (UNII-1)
Mode 4	TX AC (VHT20) Mode / CH36, CH40, CH48 (UNII-1)
Mode 5	TX AC (VHT40) Mode / CH38, CH46 (UNII-1)
Mode 6	TX AC (VHT80) Mode / CH42 (UNII-1)
Mode 8	TX N (HT20) Mode / CH52, CH60, CH64 (UNII-2A)
Mode 9	TX N (HT40) Mode / CH54, CH62 (UNII-2A)
Mode 10	TX AC (VHT20) Mode / CH52, CH60, CH64 (UNII-2A)
Mode 11	TX AC (VHT40) Mode / CH54, CH62 (UNII-2A)
Mode 12	TX AC (VHT80) Mode / CH58 (UNII-2A)
Mode 14	TX N (HT20) Mode / CH100, CH116, CH140 (UNII-2C)
Mode 15	TX N (HT40) Mode / CH102, CH110, CH134 (UNII-2C)
Mode 16	TX AC (VHT20) Mode / CH100, CH116, CH140 (UNII-2C)
Mode 17	TX AC (VHT40) Mode / CH102, CH110, CH134 (UNII-2C)
Mode 18	TX AC (VHT80) Mode / CH106, CH122 (UNII-2C)
Mode 20	TX N (HT20) Mode / CH149,CH157,CH165 (UNII-3)
Mode 21	TX N (HT40) Mode / CH151,CH159 (UNII-3)
Mode 22	TX AC (VHT20) Mode / CH149,CH157,CH165 (UNII-3)
Mode 23	TX AC (VHT40) Mode / CH151,CH159 (UNII-3)
Mode 24	TX AC (VHT80) Mode / CH155 (UNII-3)

Other Conducted test	
Final Test Mode	Description
Mode 1	TX A Mode / CH36, CH40, CH48 (UNII-1)
Mode 4	TX AC (VHT20) Mode / CH36, CH40, CH48 (UNII-1)
Mode 5	TX AC (VHT40) Mode / CH38, CH46 (UNII-1)
Mode 6	TX AC (VHT80) Mode / CH42 (UNII-1)
Mode 7	TX A Mode / CH52, CH60, CH64 (UNII-2A)
Mode 10	TX AC (VHT20) Mode / CH52, CH60, CH64 (UNII-2A)
Mode 11	TX AC (VHT40) Mode / CH54, CH62 (UNII-2A)
Mode 12	TX AC (VHT80) Mode / CH58 (UNII-2A)
Mode 13	TX A Mode / CH100, CH116, CH140 (UNII-2C)
Mode 16	TX AC (VHT20) Mode / CH100, CH116, CH140 (UNII-2C)
Mode 17	TX AC (VHT40) Mode / CH102, CH110, CH134 (UNII-2C)
Mode 18	TX AC (VHT80) Mode / CH106, CH122 (UNII-2C)
Mode 19	TX A Mode / CH149,CH157,CH165 (UNII-3)
Mode 22	TX AC (VHT20) Mode / CH149,CH157,CH165 (UNII-3)
Mode 23	TX AC (VHT40) Mode / CH151,CH159 (UNII-3)
Mode 24	TX AC (VHT80) Mode / CH155 (UNII-3)

Note:

- (1) For radiated emission below 1 GHz test, the IEEE 802.11ac40 channel 159 is found to be the worst case and recorded.
- (2) For radiated emission above 1 GHz test, 1GHz~26.5GHz and 26.5GHz~40GHz have been pre-tested and in this report only recorded the worst case. The remaining spurious points are all below the limit value of 20dB.
- (3) All the bit rate of transmitter have been tested and found the lowest rate is found to be the worst case and recorded.
- (4) The measurements for Output Power were tested, the Non Beamforming and Beamforming are recorded in the report. The worst case was Non Beamforming and only worst case were documented for other test items.
- (5) All adapters had been pre-tested and in this report only recorded the worst case.
- (6) The measurements for Output Power were tested, the worst case were IEEE 802.11a mode, IEEE 802.11ac(VHT20) mode, IEEE 802.11ac(VHT40) mode, IEEE 802.11ac(VHT80) mode, only the worst case were documented for other test items.

2.3 PARAMETERS OF TEST SOFTWARE

Non Beamforming

UNII-1			
Test Software	accessMTool V3.1.0.3		
Test Frequency (MHz)	5180	5200	5240
IEEE 802.11a	86	102	108
IEEE 802.11n (HT20)	79	91	90
IEEE 802.11ac (VHT20)	80	92	91
Test Frequency (MHz)	5190	5230	
IEEE 802.11n (HT40)	69	83	
IEEE 802.11ac (VHT40)	70	84	
Test Frequency (MHz)	5210		
IEEE 802.11ac (VHT80)	72		

UNII-2A			
Test Software	accessMTool V3.1.0.3		
Test Frequency (MHz)	5260	5300	5320
IEEE 802.11a	91	91	84
IEEE 802.11n (HT20)	67	66	66
IEEE 802.11ac (VHT20)	68	67	67
Test Frequency (MHz)	5270	5310	
IEEE 802.11n (HT40)	73	73	
IEEE 802.11ac (VHT40)	74	74	
Test Frequency (MHz)	5290		
IEEE 802.11ac (VHT80)	73		

UNII-2C			
Test Software	accessMTool V3.1.0.3		
Test Frequency (MHz)	5500	5580	5700
IEEE 802.11a	88	91	80
IEEE 802.11n (HT20)	66	66	67
IEEE 802.11ac (VHT20)	67	67	68
Test Frequency (MHz)	5510	5550	5670
IEEE 802.11n (HT40)	73	73	73
IEEE 802.11ac (VHT40)	74	74	74
Test Frequency (MHz)	5530	5610	
IEEE 802.11ac (VHT80)	72	74	

UNII-3			
Test Software	accessMTool V3.1.0.3		
Test Frequency (MHz)	5745	5785	5825
IEEE 802.11a	108	108	108
IEEE 802.11n (HT20)	96	96	97
IEEE 802.11ac (VHT20)	96	96	96
Test Frequency (MHz)	5755	5795	
IEEE 802.11n (HT40)	95	98	
IEEE 802.11ac (VHT40)	96	98	
Test Frequency (MHz)	5775		
IEEE 802.11ac (VHT80)	85		

Beamforming

UNII-1			
Test Software	accessMTool V3.1.0.3		
Test Frequency (MHz)	5180	5200	5240
IEEE 802.11n (HT20)	78	90	89
IEEE 802.11ac (VHT20)	79	91	90
Test Frequency (MHz)	5190	5230	
IEEE 802.11n (HT40)	68	82	
IEEE 802.11ac (VHT40)	69	83	
Test Frequency (MHz)	5210		
IEEE 802.11ac (VHT80)	71		

UNII-2A			
Test Software	accessMTool V3.1.0.3		
Test Frequency (MHz)	5260	5300	5320
IEEE 802.11n (HT20)	66	65	65
IEEE 802.11ac (VHT20)	67	66	66
Test Frequency (MHz)	5270	5310	
IEEE 802.11n (HT40)	72	72	
IEEE 802.11ac (VHT40)	73	73	
Test Frequency (MHz)	5290		
IEEE 802.11ac (VHT80)	72		

UNII-2C			
Test Software	accessMTool V3.1.0.3		
Test Frequency (MHz)	5500	5580	5700
IEEE 802.11n (HT20)	65	65	66
IEEE 802.11ac (VHT20)	66	66	67
Test Frequency (MHz)	5510	5550	5670
IEEE 802.11n (HT40)	72	72	72
IEEE 802.11ac (VHT40)	73	73	73
Test Frequency (MHz)	5530	5610	
IEEE 802.11ac (VHT80)	71	73	

UNII-3			
Test Software	accessMTool V3.1.0.3		
Test Frequency (MHz)	5745	5785	5825
IEEE 802.11n (HT20)	95	95	96
IEEE 802.11ac (VHT20)	95	95	95
Test Frequency (MHz)	5755	5795	
IEEE 802.11n (HT40)	94	97	
IEEE 802.11ac (VHT40)	95	97	
Test Frequency (MHz)	5775		
IEEE 802.11ac (VHT80)	84		

2.4 DUTY CYCLE

If duty cycle is $\geq 98\%$, duty factor is not required.

If duty cycle is $< 98\%$, duty factor shall be considered.

The output power = measured power + duty factor.

The power spectral density = measured power spectral density + duty factor.

IEEE 802.11a

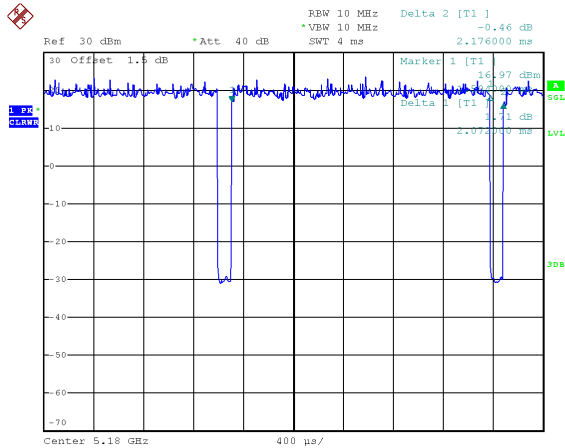

Date: 15.JUL.2020 14:16:13

Duty cycle = $2.072 \text{ ms} / 2.176 \text{ ms} = 95.22\%$
 Duty Factor = $10 \log(1 / \text{Duty cycle}) = 0.21$

IEEE 802.11n (HT20)

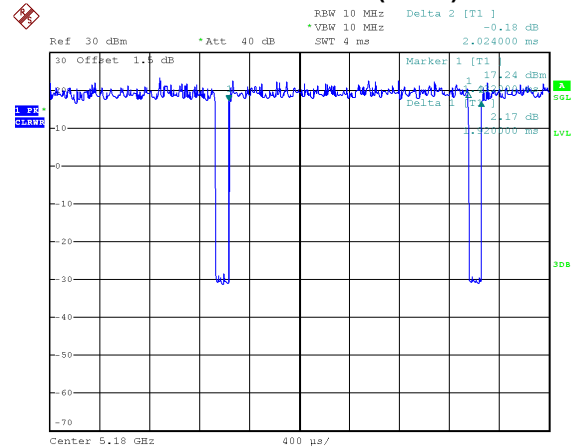

Date: 15.JUL.2020 14:16:40

Duty cycle = $1.920 \text{ ms} / 2.024 \text{ ms} = 94.86\%$
 Duty Factor = $10 \log(1 / \text{Duty cycle}) = 0.23$

IEEE 802.11n (HT40)

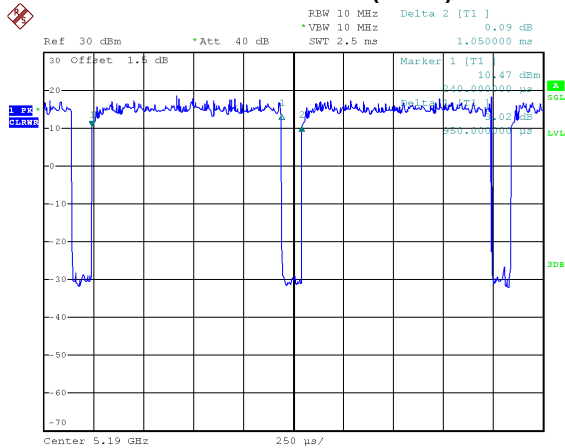

Date: 15.JUL.2020 14:26:11

Duty cycle = $0.950 \text{ ms} / 1.050 \text{ ms} = 90.48\%$
 Duty Factor = $10 \log(1 / \text{Duty cycle}) = 0.43$

IEEE 802.11ac (VHT20)

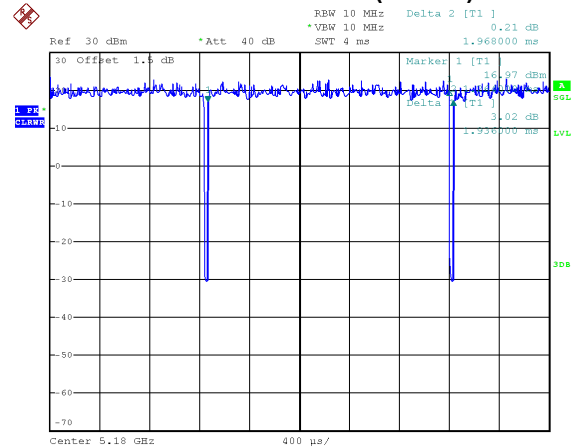

Date: 15.JUL.2020 14:23:26

Duty cycle = $1.936 \text{ ms} / 1.968 \text{ ms} = 98.37\%$
 Duty Factor = $10 \log(1 / \text{Duty cycle}) = 0.00$

IEEE 802.11ac (VHT40)

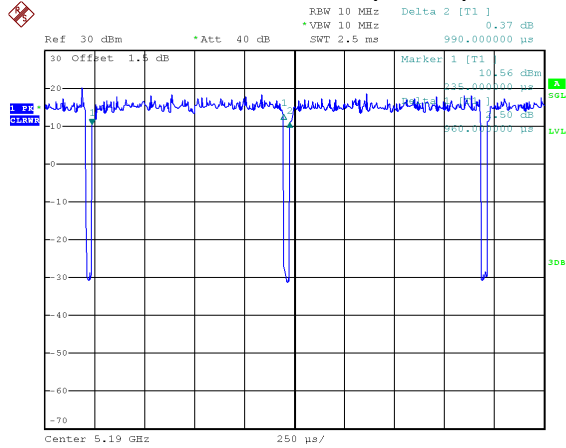

Date: 15.JUL.2020 14:26:30

Duty cycle = 0.960 ms / 0.990 ms = 96.97%
 Duty Factor = $10 \log(1 / \text{Duty cycle}) = 0.13$

IEEE 802.11ac (VHT80)

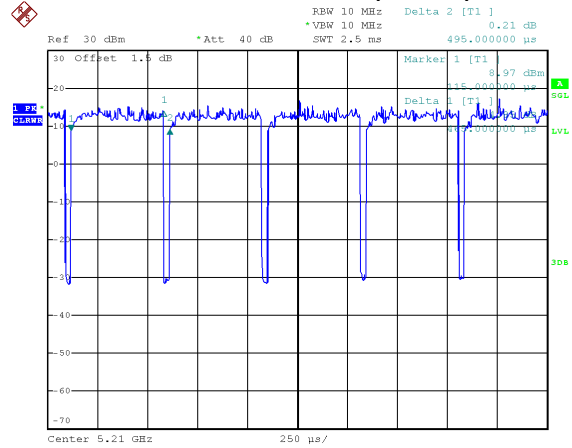

Date: 15.JUL.2020 14:27:20

Duty cycle = 0.465 ms / 0.495 ms = 93.94%
 Duty Factor = $10 \log(1 / \text{Duty cycle}) = 0.27$

NOTE:

For IEEE 802.11a, IEEE 802.11n (HT20) and IEEE 802.11ac (VHT20):

For radiated emissions frequency above 1 GHz, the resolution bandwidth of test receiver/spectrum analyzer is 1 MHz and the video bandwidth is 1 kHz (Duty cycle < 98%).

For IEEE 802.11n (HT40) and IEEE 802.11ac (VHT40):

For radiated emissions frequency above 1 GHz, the resolution bandwidth of test receiver/spectrum analyzer is 1 MHz and the video bandwidth is 2 kHz (Duty cycle < 98%).

For IEEE 802.11ac (VHT80):

For radiated emissions frequency above 1 GHz, the resolution bandwidth of test receiver/spectrum analyzer is 1 MHz and the video bandwidth is 3 kHz (Duty cycle < 98%).

2.5 BLOCK DIAGRAM SHOWING THE CONFIGURATION OF SYSTEM TESTED

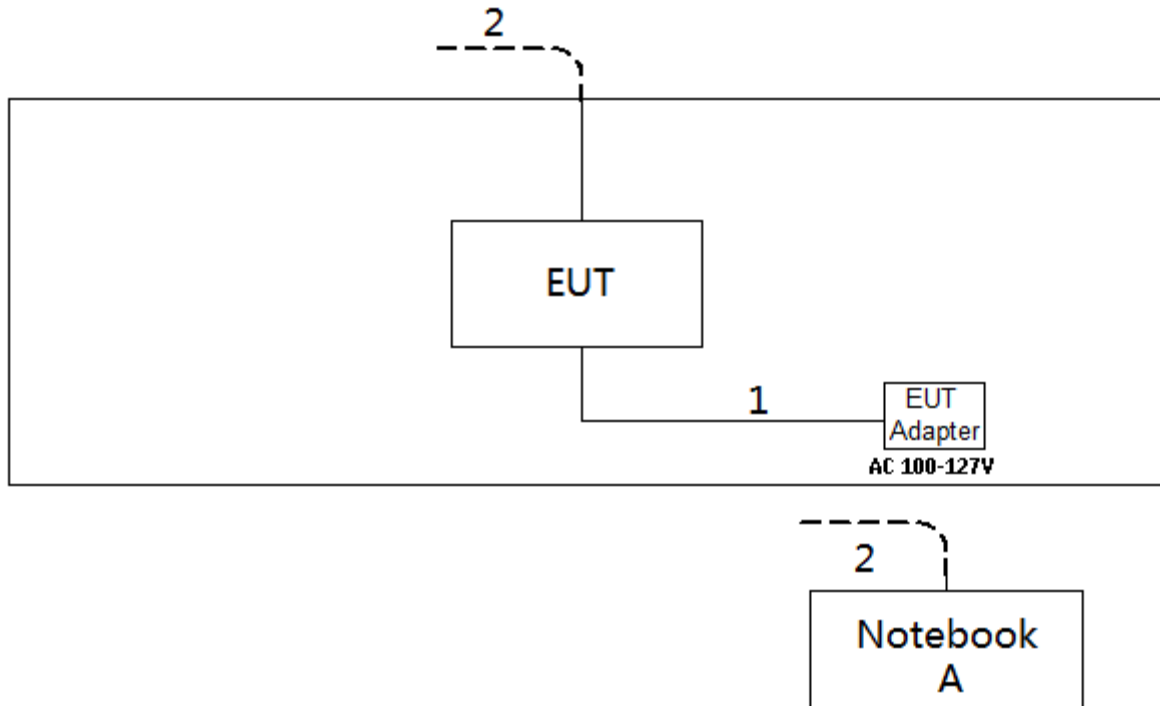

2.6 SUPPORT UNITS

Item	Equipment	Brand	Model No.	Series No.
A	Notebook	Dell	Inspiron 15-7559	N/A

Item	Cable Type	Shielded Type	Ferrite Core	Length
1	DC Cable	NO	NO	1.5m
2	RJ45 Cable	NO	NO	10m

3. AC POWER LINE CONDUCTED EMISSIONS TEST

3.1 LIMIT

Frequency (MHz)	Limit (dB μ V)	
	Quasi-peak	Average
0.15 - 0.50	66 to 56*	56 to 46*
0.50 - 5.0	56	46
5.0 - 30.0	60	50

NOTE:

- (1) The tighter limit applies at the band edges.
- (2) The limit of " * " marked band means the limitation decreases linearly with the logarithm of the frequency in the range.

The following table is the setting of the receiver

Receiver Parameter	Setting
Attenuation	10 dB
Start Frequency	0.15 MHz
Stop Frequency	30 MHz
IF Bandwidth	9 KHz

3.2 TEST PROCEDURE

- a. The EUT was placed 0.8 meters from the horizontal ground plane with EUT being connected to the power mains through a line impedance stabilization network (LISN). All other support equipment powered from additional LISN(s). The LISN provide 50 Ohm/ 50uH of coupling impedance for the measuring instrument.
- b. Interconnecting cables that hang closer than 40 cm to the ground plane shall be folded back and forth in the center forming a bundle 30 to 40 cm long.
- c. I/O cables that are not connected to a peripheral shall be bundled in the center. The end of the cable may be terminated, if required, using the correct terminating impedance. The overall length shall not exceed 1 m.
- d. LISN at least 80 cm from nearest part of EUT chassis.
- e. For the actual test configuration, please refer to the related Item -EUT Test Photos.

3.3 DEVIATION FROM TEST STANDARD

No deviation

3.4 TEST SETUP

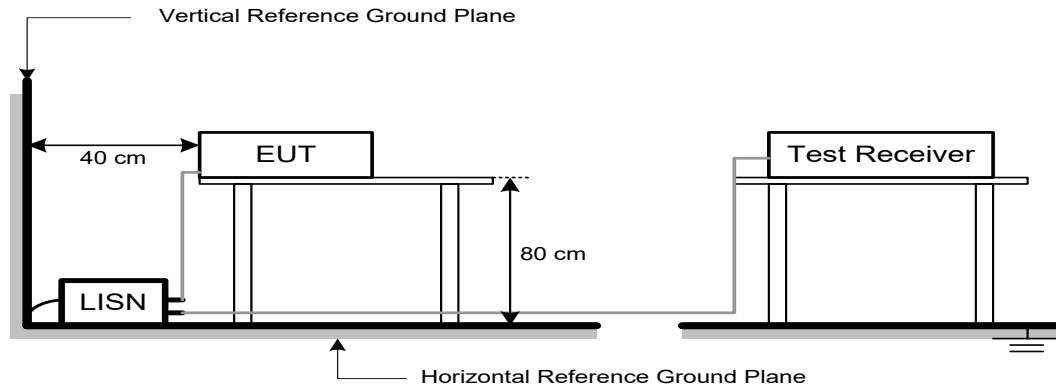

3.5 EUT OPERATION CONDITIONS

The EUT was configured for testing in a typical fashion (as a customer would normally use it). The EUT has been programmed to continuously transmit during test. This operating condition was tested and used to collect the included data.

The EUT was programmed to be in continuously transmitting/TX mode.

3.6 TEST RESULTS

Please refer to the APPENDIX A.

4. RADIATED EMISSIONS TEST

4.1 LIMIT

In case the emission fall within the restricted band specified on 15.205(a), then the 15.209(a) limit in the table below has to be followed.

LIMITS OF RADIATED EMISSIONS MEASUREMENT (9 kHz to 1000 MHz)

Frequency (MHz)	Field Strength (microvolts/meter)	Measurement Distance (meters)
0.009-0.490	2400/F(kHz)	300
0.490-1.705	24000/F(kHz)	30
1.705-30.0	30	30
30-88	100	3
88-216	150	3
216-960	200	3
Above 960	500	3

LIMITS OF UNWANTED EMISSION OUT OF THE RESTRICTED BANDS

Frequency (MHz)	EIRP Limit (dBm/MHz)	Equivalent Field Strength at 3m (dBμV/m)
5150-5250	-27	68.3
5250-5350	-27	68.3
5470-5725	-27	68.3
5725-5850	-27 NOTE (2)	68.3
	10 NOTE (2)	105.3
	15.6 NOTE (2)	110.9
	27 NOTE (2)	122.3

NOTE:

(1) The following formula is used to convert the equipment isotropic radiated power (eirp) to field strength:

$$E = \frac{1000000\sqrt{30P}}{3} \mu\text{V/m, where P is the eirp (Watts)}$$

(2) According to 15.407(b)(4)(i), all emissions shall be limited to a level of -27 dBm/MHz at 75 MHz or more above or below the band edge increasing linearly to 10 dBm/MHz at 25 MHz above or below the band edge, and from 25 MHz above or below the band edge increasing linearly to a level of 15.6 dBm/MHz at 5 MHz above or below the band edge, and from 5 MHz above or below the band edge increasing linearly to a level of 27 dBm/MHz at the band edge.

4.2 TEST PROCEDURE

- a. The measuring distance of 3 m shall be used for measurements. The EUT was placed on the top of a rotating table 0.8 meter above the ground at a 3 meter semi-anechoic chamber. The table was rotated 360 degrees to determine the position of the highest radiation.(below 1GHz)
- b. The measuring distance of 3 m shall be used for measurements. The EUT was placed on the top of a rotating table 1.5 meter above the ground at a 3 meter semi-anechoic chamber. The table was rotated 360 degrees to determine the position of the highest radiation.(above 1GHz)
- c. The height of the equipment or of the substitution antenna shall be 0.8m or 1.5m; the height of the test antenna shall vary between 1 m to 4 m. Both horizontal and vertical polarizations of the antenna are set to make the measurement.
- d. For each suspected emission, the EUT was arranged to its worst case and then the antenna was tuned to heights find the maximum reading (used Bore sight function).
- e. The receiver system was set to peak and average detect function and specified bandwidth with maximum hold mode when the test frequency is above 1 GHz.
- f. The initial step in collecting radiated emission data is a receiver peak detector mode pre-scanning the measurement frequency range. Significant peaks are then marked and then Quasi Peak detector mode re-measured.
- g. All readings are Peak unless otherwise stated QP in column of Note. Peak denotes that the Peak reading compliance with the QP Limits and then QP Mode measurement didn't perform. (below 1 GHz)
- h. All readings are Peak Mode value unless otherwise stated AVG in column of Note. If the Peak Mode Measured value compliance with the Peak Limits and lower than AVG Limits, the EUT shall be deemed to meet both Peak & AVG Limits and then only Peak Mode was measured, but AVG Mode didn't perform. (above 1 GHz)
- i. For the actual test configuration, please refer to the related Item –EUT Test Photos.

4.3 DEVIATION FROM TEST STANDARD

No deviation

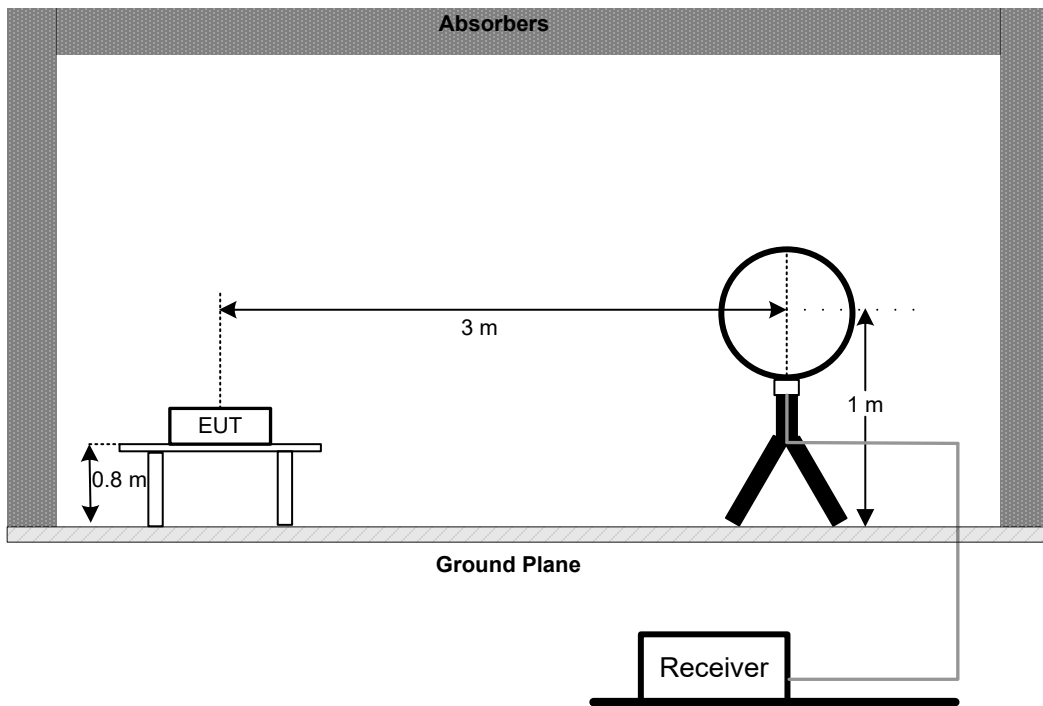
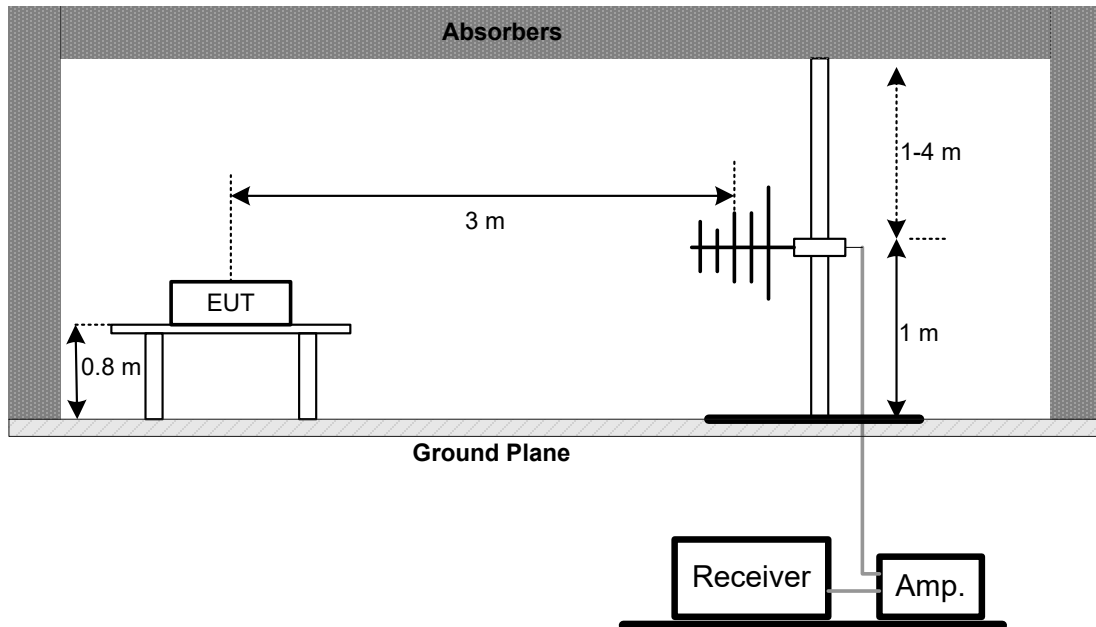
4.4 TEST SETUP**9 kHz to 30 MHz****30 MHz to 1 GHz**

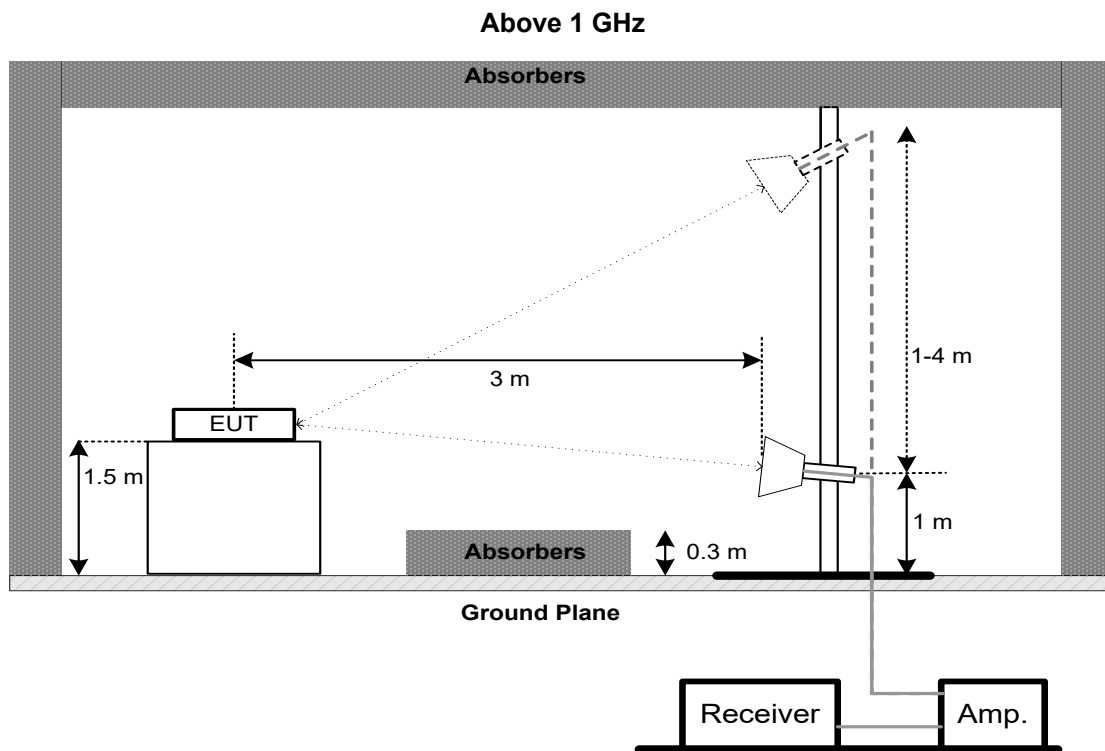

4.5 EUT OPERATION CONDITIONS

The EUT tested system was configured as the statements of 3.5 unless otherwise a special operating condition is specified in the follows during the testing.

4.6 TEST RESULTS - 9 KHZ to 30 MHZ

Please refer to the APPENDIX B

Remark:

- (1) Distance extrapolation factor = $40 \log (\text{specific distance} / \text{test distance})$ (dB).
- (2) Limit line = specific limits (dBuV) + distance extrapolation factor.

4.7 TEST RESULTS - 30 MHZ TO 1000 MHZ

Please refer to the APPENDIX C.

4.8 TEST RESULTS - ABOVE 1000 MHZ

Please refer to the APPENDIX D.

Remark:

- (1) No limit: This is fundamental signal, the judgment is not applicable.
For fundamental signal judgment was referred to Peak output test.

5. BANDWIDTH TEST

5.1 LIMIT

FCC Part15, Subpart E (15.407)			
Section	Test Item	Limit	Frequency Range (MHz)
15.407(a) 15.407(e)	26 dB Bandwidth	-	5150-5250
	26 dB Bandwidth	-	5250-5350
	26 dB Bandwidth	-	5470-5725
	6 dB Bandwidth	Minimum 500 kHz	5725-5850

5.2 TEST PROCEDURE

a. The EUT was directly connected to the spectrum analyzer and antenna output port as show in the block diagram below

b. Spectrum Setting:

For UNII-1, UNII-2A, UNII-2C:

Spectrum Parameter	Setting
Attenuation	Auto
Span Frequency	> 26 dB Bandwidth
RBW	300 kHz (Bandwidth 20 MHz & Bandwidth 40 MHz) 1 MHz (Bandwidth 80 MHz)
VBW	1 MHz (Bandwidth 20 MHz & Bandwidth 40 MHz) 3 MHz (Bandwidth 80 MHz)
Detector	Peak
Trace	Max Hold
Sweep Time	Auto

For UNII-3:

Spectrum Parameter	Setting
Attenuation	Auto
Span Frequency	6 dB Bandwidth
RBW	100 kHz
VBW	300 kHz
Detector	Peak
Trace	Max Hold
Sweep Time	Auto

c. Measured the spectrum width with power higher than 26 dB / 6 dB below carrier

5.3 DEVIATION FROM STANDARD

No deviation.

5.4 TEST SETUP**5.5 EUT OPERATION CONDITIONS**

The EUT was programmed to be in continuously transmitting mode.

5.6 TEST RESULTS

Please refer to the APPENDIX E.

6. MAXIMUM OUTPUT POWER TEST

6.1 LIMIT

FCC Part15, Subpart E (15.407)			
Section	Test Item	Limit	Frequency Range (MHz)
15.407(a)	Maximum Output Power	AP device: 1 Watt (30 dBm) Client device: 250 mW (24 dBm)	5150-5250
		250 mW (24 dBm)	5250-5350
		250 mW (24 dBm)	5470-5725
		1 Watt (30dBm)	5725-5850

Note:

- a. For an indoor access point operating in the band 5.15-5.25 GHz, the maximum conducted output power over the frequency band of operation shall not exceed 1 W provided the maximum antenna gain does not exceed 6 dBi. In addition, the maximum power spectral density shall not exceed 17 dBm in any 1 megahertz band. If transmitting antennas of directional gain greater than 6 dBi are used, both the maximum conducted output power and the maximum power spectral density shall be reduced by the amount in dB that the directional gain of the antenna exceeds 6 dBi.
- b. For the 5.25-5.35 GHz and 5.47-5.725 GHz bands, the maximum conducted output power over the frequency bands of operation shall not exceed the lesser of 250 mW or 11 dBm + 10log B, where B is the 26dB Bandwidth in megahertz.

6.2 TEST PROCEDURE

- a. The EUT was directly connected to the power meter and antenna output port as show in the block diagram below.
- b. Test test was performed in accordance with method of FCC KDB 789033 D02 General UNII Test Procedures New Rules v02r01.

6.3 DEVIATION FROM STANDARD

No deviation.

6.4 TEST SETUP



6.5 EUT OPERATION CONDITIONS

The EUT was programmed to be in continuously transmitting mode.

6.6 TEST RESULTS

Please refer to the APPENDIX F.

7. POWER SPECTRAL DENSITY TEST

7.1 LIMIT

FCC Part15, Subpart E (15.407)			
Section	Test Item	Limit	Frequency Range (MHz)
15.407(a)	Power Spectral Density	AP device: 17 dBm/MHz Client device: 11 dBm/MHz	5150-5250
		11 dBm/MHz	5250-5350
		11 dBm/MHz	5470-5725
		30 dBm/500 kHz	5725-5850

7.2 TEST PROCEDURE

a. The EUT was directly connected to the spectrum analyzer and antenna output port as show in the block diagram below.

b. Spectrum Setting:

For UNII-1, UNII-2A, UNII-2C:

Spectrum Parameter	Setting
Attenuation	Auto
Span Frequency	Encompass the entire emissions bandwidth (EBW) of the signal
RBW	= 1 MHz.
VBW	≥ 3 MHz.
Detector	RMS
Trace average	100 trace
Sweep Time	Auto

For UNII-3:

Spectrum Parameter	Setting
Attenuation	Auto
Span Frequency	Encompass the entire emissions bandwidth (EBW) of the signal
RBW	100 kHz.
VBW	300 kHz.
Detector	RMS
Trace average	100 trace
Sweep Time	Auto

Note:

- For UNII-3, according to KDB publication 789033 D02 General UNII Test Procedures New Rules v02r01, section II.F.5., it is acceptable to set RBW at 100kHz and VBW at 300kHz if the spectrum analyzer does not have 500 kHz RBW.
- The value measured with RBW=100kHz is to be added with $10\log(500 \text{ kHz}/100\text{kHz})$ which is +7 dB. During the test, the offset has added 7 dB, For example, if the offset value is +2dB , then the converted value will be $2+7=9\text{dB}$ using RBW=100kHz.

7.3 DEVIATION FROM STANDARD

No deviation.

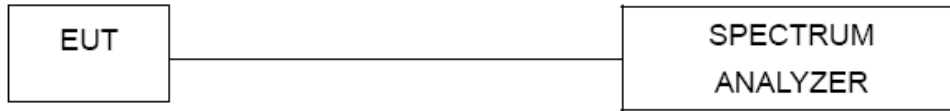
7.4 TEST SETUP**7.5 EUT OPERATION CONDITIONS**

The EUT was programmed to be in continuously transmitting mode.

7.6 TEST RESULTS

Please refer to the APPENDIX G.

8. FREQUENCY STABILITY MEASUREMENT

8.1 LIMIT

FCC Part15, Subpart E (15.407)			
Section	Test Item	Limit	Frequency Range (MHz)
15.407(g)	Frequency Stability	An emission is maintained within the band of operation under all conditions of normal operation as specified in the users manual.	5150-5250
			5250-5350
			5470-5725
			5725-5850

8.2 TEST PROCEDURE

- a. The EUT was directly connected to the spectrum analyzer and antenna output port as show in the block diagram below.
- b. Spectrum Setting:

Spectrum Parameter	Setting
Attenuation	Auto
Span Frequency	Entire absence of modulation emissions bandwidth
RBW	10 kHz
VBW	10 kHz
Sweep Time	Auto

- c. The test extreme voltage is to change the primary supply voltage from 85 to 115 percent of the nominal value.
- d. User manual temperature is -5°C~45°C.

8.3 DEVIATION FROM STANDARD

No deviation.

8.4 TEST SETUP

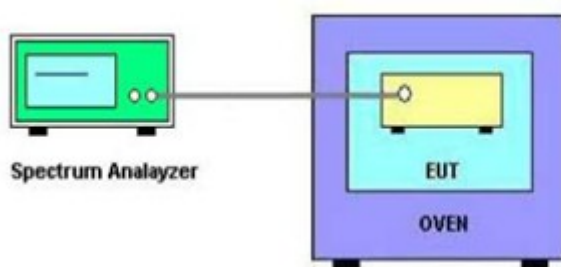

8.5 EUT OPERATION CONDITIONS

The EUT was programmed to be in continuously transmitting mode.

8.6 TEST RESULTS

Please refer to the APPENDIX H.

9. MEASUREMENT INSTRUMENTS LIST

AC Power Line Conducted Emissions					
Item	Kind of Equipment	Manufacturer	Type No.	Serial No.	Calibrated until
1	EMI Test Receiver	R&S	ESCI	100382	Feb. 28, 2021
2	LISN	EMCO	3816/2	52765	Mar. 01, 2021
3	TWO-LINE V-NETWORK	R&S	ENV216	101447	Feb. 28, 2021
4	50Ω Terminator	SHX	TF5-3	15041305	Mar. 01, 2021
5	Measurement Software	Farad	EZ-EMC Ver.NB-03A1-01	N/A	N/A
6	Cable	N/A	RG223	12m	Mar. 10, 2021

Radiated Emissions - 9 kHz to 30 MHz					
Item	Kind of Equipment	Manufacturer	Type No.	Serial No.	Calibrated until
1	Antenna	EM	EM-6876-1	230	Apr. 16, 2021
2	Cable	N/A	RG 213/U	N/A	May 29, 2021
3	EMI Test Receiver	R&S	ESCI	100895	Feb. 28, 2021
4	Measurement Software	Farad	EZ-EMC Ver.NB-03A1-01	N/A	N/A

Radiated Emissions - 30 MHz to 1 GHz					
Item	Kind of Equipment	Manufacturer	Type No.	Serial No.	Calibrated until
1	Antenna	Schwarzbeck	VULB9160	9160-3232	Mar. 09, 2021
2*	Amplifier	HP	8447D	2944A09673	Aug. 11, 2021
3	Receiver	Agilent	N9038A	MY52130039	Jul. 25, 2021
4	Cable	emci	LMR-400(30MHz-1 GHz)(8m+5m)	N/A	May 22, 2021
5	Controller	CT	SC100	N/A	N/A
6	Controller	MF	MF-7802	MF780208416	N/A
7	Measurement Software	Farad	EZ-EMC Ver.NB-03A1-01	N/A	N/A

Radiated Emissions - Above 1 GHz					
Item	Kind of Equipment	Manufacturer	Type No.	Serial No.	Calibrated until
1	Double Ridged Guide Antenna	ETS	3115	75789	May 12, 2021
2	Broad-Band Horn Antenna	Schwarzbeck	BBHA 9170	9170319	Jul. 07, 2021
3	Amplifier	Agilent	8449B	3008A02333	Mar. 01, 2021
4	Microwave Preamplifier With Adaptor	EMC INSTRUMENT	EMC2654045	980039 & HA01	Mar. 07, 2021
5	Receiver	Agilent	N9038A	MY52130039	Jul. 25, 2021
6	Controller	CT	SC100	N/A	N/A
7	Controller	MF	MF-7802	MF780208416	N/A
8	Cable	N/A	EMC104-SM-SM-6000	N/A	May 09, 2021
9	Measurement Software	Farad	EZ-EMC Ver.NB-03A1-01	N/A	N/A

Bandwidth & Power Spectral Density					
Item	Kind of Equipment	Manufacturer	Type No.	Serial No.	Calibrated until
1	Spectrum Analyzer	R&S	FSP40	100185	Jul. 25, 2021

Maximum Output Power					
Item	Kind of Equipment	Manufacturer	Type No.	Serial No.	Calibrated until
1	Peak Power Analyzer	Keysight	8990B	MY51000506	Jul. 25, 2021
2	Wideband power sensor	Keysight	N1923A	MY58310004	Jul. 25, 2021

Frequency Stability					
Item	Kind of Equipment	Manufacturer	Type No.	Serial No.	Calibrated until
1	Spectrum Analyzer	R&S	FSP40	100185	Jul. 25, 2021
2	Const Temp. & Humidity Chamber	CEPREI	CEEC-M64T-40	15-008	Feb. 28, 2021

Remark: "N/A" denotes no model name, serial no. or calibration specified.

"**" calibration period of equipment list is three year.

Except * item, all calibration period of equipment list is one year.

APPENDIX A - AC POWER LINE CONDUCTED EMISSIONS

Test Mode: TX AC40 MODE CHANNEL 159

Line

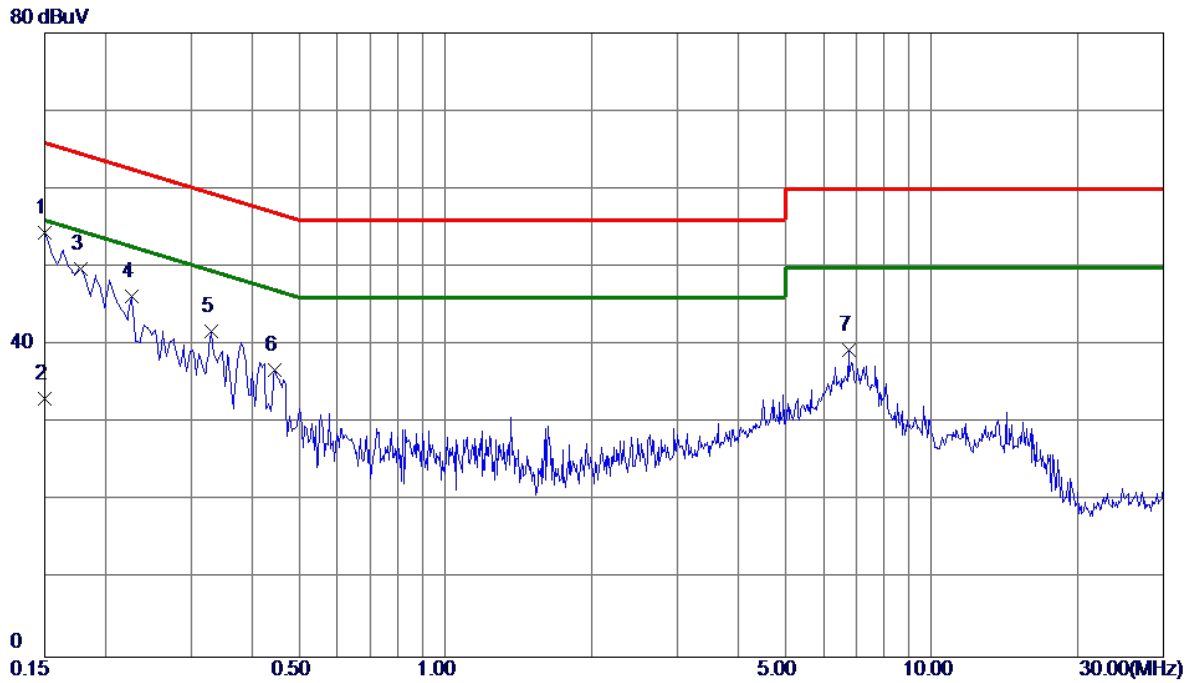

No.	Freq. MHz	Reading Level dBuV	Correct Factor dB	Measure ment dBuV	Limit dBuV	Margin dB	Detector	Comment
1 *	0.1500	44.75	9.67	54.42	66.00	-11.58	Peak	
2	0.1500	23.40	9.67	33.07	56.00	-22.93	AVG	
3	0.1777	39.91	9.84	49.75	64.59	-14.84	Peak	
4	0.2265	36.36	9.89	46.25	62.58	-16.33	Peak	
5	0.3300	31.93	9.90	41.83	59.45	-17.62	Peak	
6	0.4470	26.83	9.93	36.76	56.93	-20.17	Peak	
7	6.7560	28.87	10.46	39.33	60.00	-20.67	Peak	

REMARKS:

- (1) Measurement Value = Reading Level + Correct Factor.
- (2) Margin Level = Measurement Value - Limit Value.
- (3) The test result has included the cable loss.

Test Mode: TX AC40 MODE CHANNEL 159

Neutral

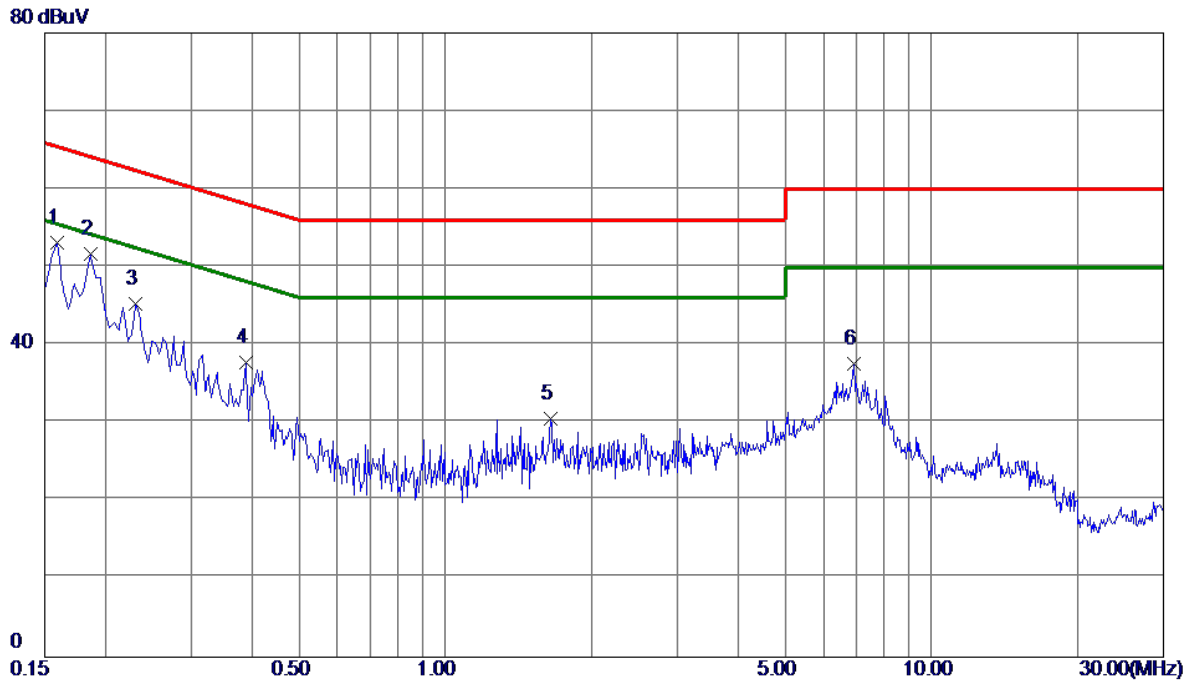

No.	Freq. MHz	Reading Level dBuV	Correct Factor dB	Measure ment dBuV	Limit dBuV	Margin dB	Detector	Comment
1 *	0.1590	43.24	9.81	53.05	65.52	-12.47	Peak	
2	0.1860	41.74	9.96	51.70	64.21	-12.51	Peak	
3	0.2310	35.36	9.99	45.35	62.41	-17.06	Peak	
4	0.3885	27.67	10.08	37.75	58.10	-20.35	Peak	
5	1.6485	20.22	10.38	30.60	56.00	-25.40	Peak	
6	6.9090	26.77	10.81	37.58	60.00	-22.42	Peak	

REMARKS:

- (1) Measurement Value = Reading Level + Correct Factor.
- (2) Margin Level = Measurement Value - Limit Value.
- (3) The test result has included the cable loss.

APPENDIX B - RADIATED EMISSION - 9 KHZ TO 30 MHZ

Test Mode: TX AC40 MODE CHANNEL 159

Ant 0°

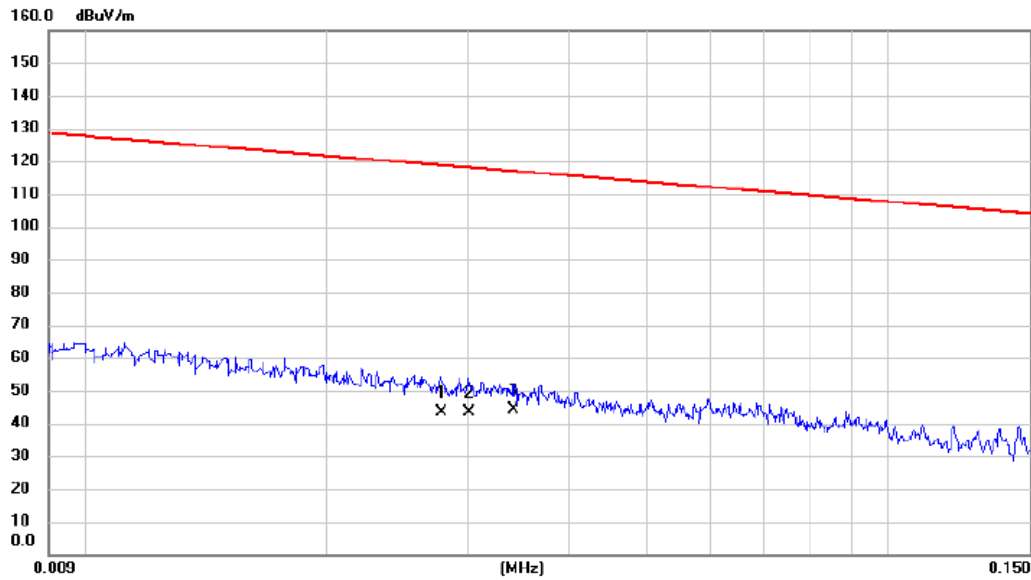

No.	Mk.	Freq.	Reading Level	Correct Factor	Measurement	Limit	Margin	Antenna Height	Table Degree	
		MHz	dBuV	dB	dBuV/m	dBuV/m	dB	cm	degree	Comment
1		0.0278	30.46	12.92	43.38	118.72	-75.34	AVG		
2		0.0301	30.62	12.86	43.48	118.03	-74.55	AVG		
3	*	0.0342	31.62	12.76	44.38	116.92	-72.54	AVG		

REMARKS:

- (1) Measurement Value = Reading Level + Correct Factor.
- (2) Margin Level = Measurement Value - Limit Value.

Test Mode: TX AC40 MODE CHANNEL 159

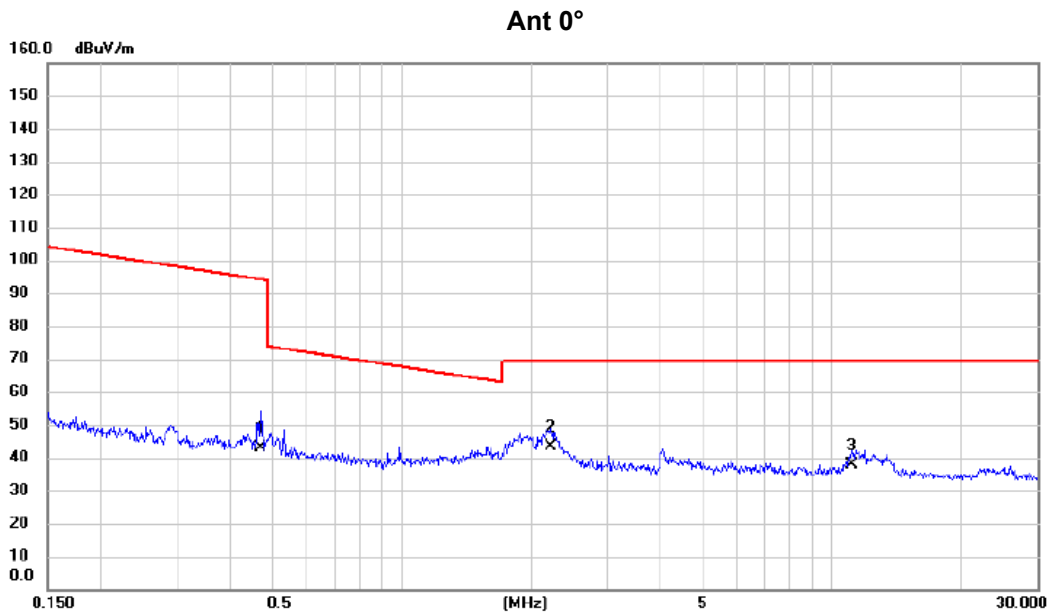

No.	Mk.	Freq.	Reading Level	Correct Factor	Measurement	Limit	Margin	Antenna Height	Table Degree	
		MHz	dBuV	dB	dBuV/m	dBuV/m	dB	cm	degree	Comment
1		0.4686	31.32	11.88	43.20	94.19	-50.99			AVG
2	*	2.2250	32.63	10.96	43.59	69.54	-25.95			QP
3		11.1386	26.86	11.07	37.93	69.54	-31.61			QP

REMARKS:

- (1) Measurement Value = Reading Level + Correct Factor.
- (2) Margin Level = Measurement Value - Limit Value.

Test Mode: TX AC40 MODE CHANNEL 159

Ant 90°

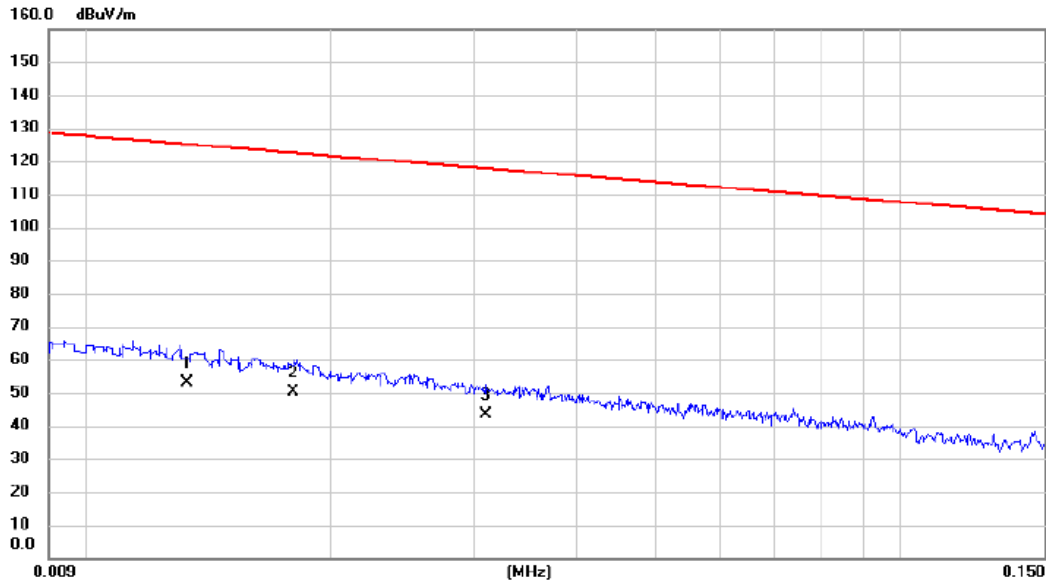

No.	Mk.	Freq.	Reading Level	Correct Factor	Measurement	Limit	Margin	Antenna Height	Table Degree	
		MHz	dBuV	dB	dBuV/m	dBuV/m	dB	cm	degree	Comment
1	*	0.0133	37.62	15.21	52.83	125.13	-72.30			AVG
2		0.0180	36.32	13.75	50.07	122.50	-72.43			AVG
3		0.0310	30.61	12.84	43.45	117.78	-74.33			AVG

REMARKS:

- (1) Measurement Value = Reading Level + Correct Factor.
- (2) Margin Level = Measurement Value - Limit Value.

Test Mode: TX AC40 MODE CHANNEL 159

Ant 90°

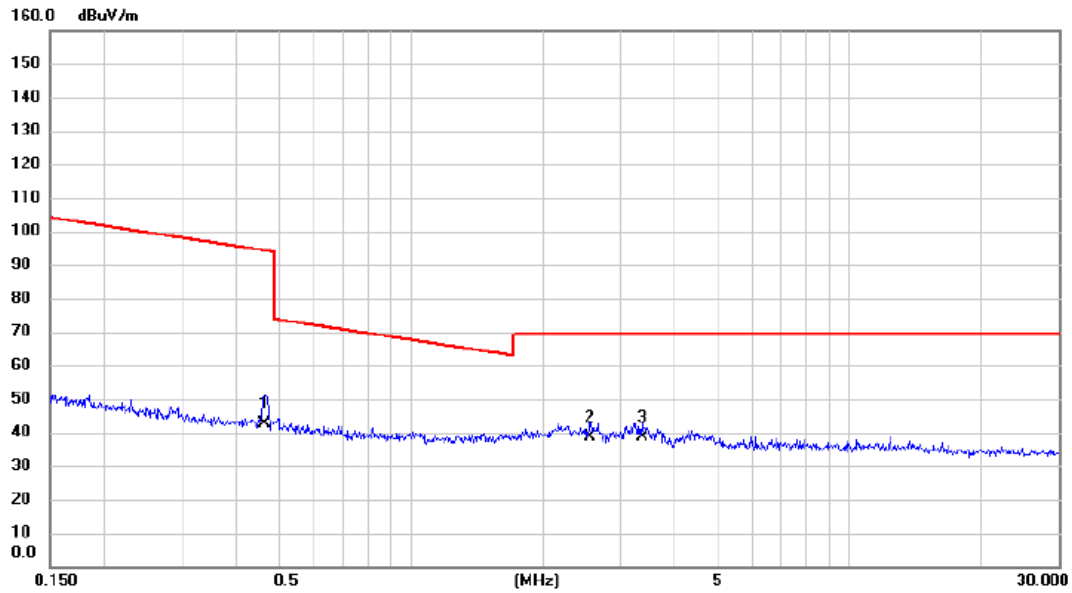

No. Mk.	Freq. MHz	Reading Level dBuV	Correct Factor dB	Measurement dBuV/m	Limit dBuV/m	Margin dB	Detector	Antenna Height cm	Table Degree	Comment
1	0.4637	30.62	11.90	42.52	94.28	-51.76	AVG			
2 *	2.5671	27.95	10.77	38.72	69.54	-30.82	QP			
3	3.3635	28.13	10.56	38.69	69.54	-30.85	QP			

REMARKS:

- (1) Measurement Value = Reading Level + Correct Factor.
- (2) Margin Level = Measurement Value - Limit Value.

APPENDIX C - RADIATED EMISSION - 30 MHZ TO 1 GHZ

Test Mode: TX AC40 MODE CHANNEL 159

Vertical

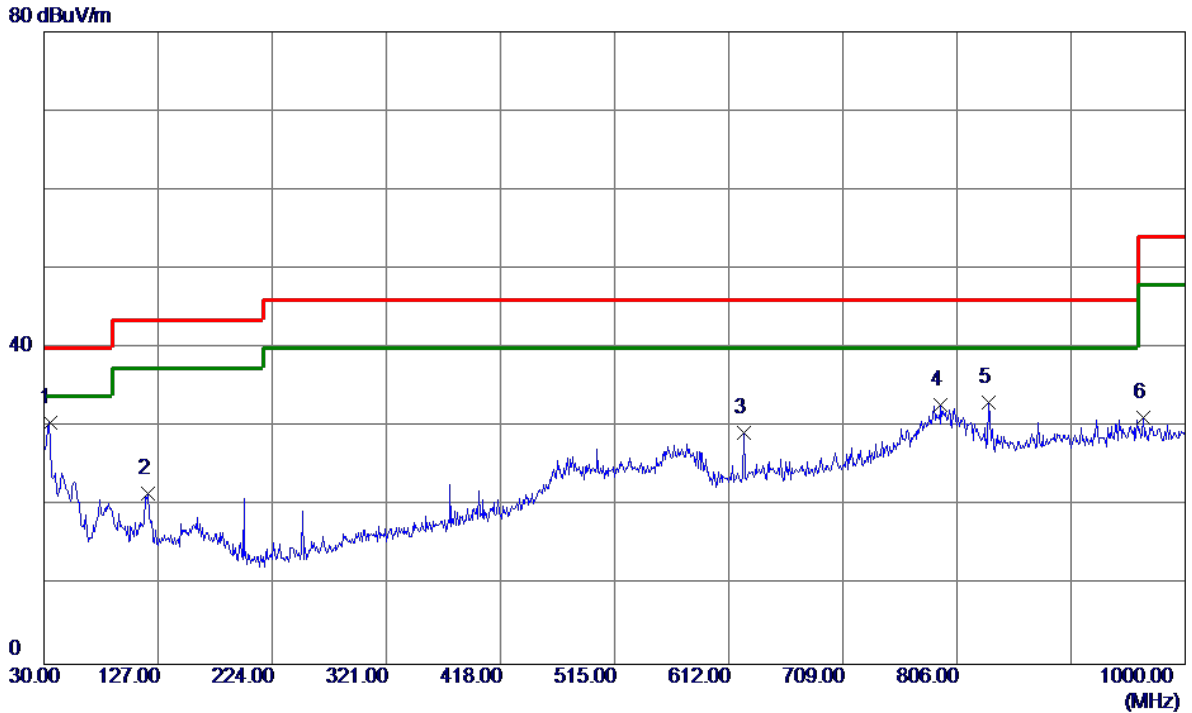

No.	Freq. MHz	Reading Level dBuV/m	Correct Factor dB	Measure ment dBuV/m	Limit dBuV/m	Margin dB	Detector	Comment
1 *	34.8500	45.14	-14.59	30.55	40.00	-9.45	Peak	
2	118.2700	34.67	-13.00	21.67	43.50	-21.83	Peak	
3	624.6100	34.09	-4.82	29.27	46.00	-16.73	Peak	
4	792.4200	35.47	-2.63	32.84	46.00	-13.16	Peak	
5	833.1599	35.10	-2.01	33.09	46.00	-12.91	Peak	
6	964.1100	30.86	0.41	31.27	54.00	-22.73	Peak	

REMARKS:

- (1) Measurement Value = Reading Level + Correct Factor.
- (2) Margin Level = Measurement Value - Limit Value.

Test Mode: TX AC40 MODE CHANNEL 159

Horizontal

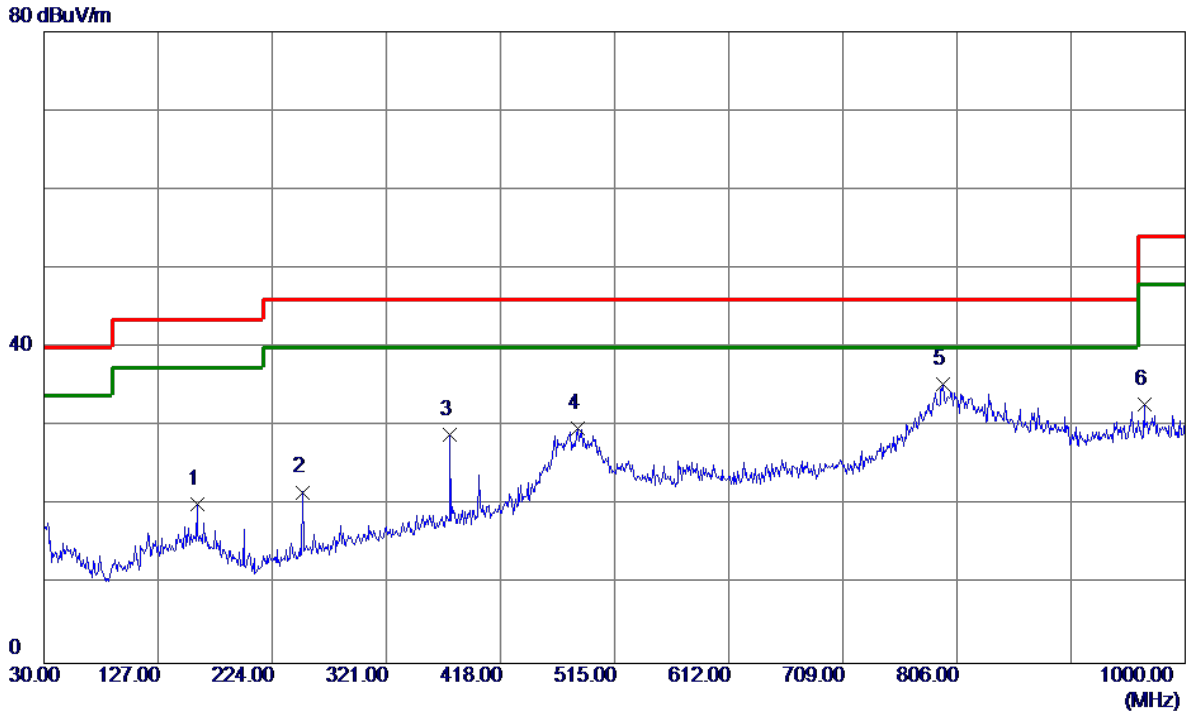

No.	Freq. MHz	Reading Level dBuV/m	Correct Factor dB	Measure ment dBuV/m	Limit dBuV/m	Margin dB	Detector	Comment
1	159.9800	30.88	-10.67	20.21	43.50	-23.29	Peak	
2	250.1900	34.96	-13.28	21.68	46.00	-24.32	Peak	
3	375.3200	38.59	-9.60	28.99	46.00	-17.01	Peak	
4	483.9600	37.14	-7.38	29.76	46.00	-16.24	Peak	
5 *	794.3600	38.02	-2.61	35.41	46.00	-10.59	Peak	
6	965.0800	32.42	0.43	32.85	54.00	-21.15	Peak	

REMARKS:

- (1) Measurement Value = Reading Level + Correct Factor.
- (2) Margin Level = Measurement Value - Limit Value.

APPENDIX D - RADIATED EMISSION - ABOVE 1000 MHZ

Orthogonal Axis	X
Test Mode	UNII-1_TX A Mode 5180 MHz

Vertical

130 dBuV/m

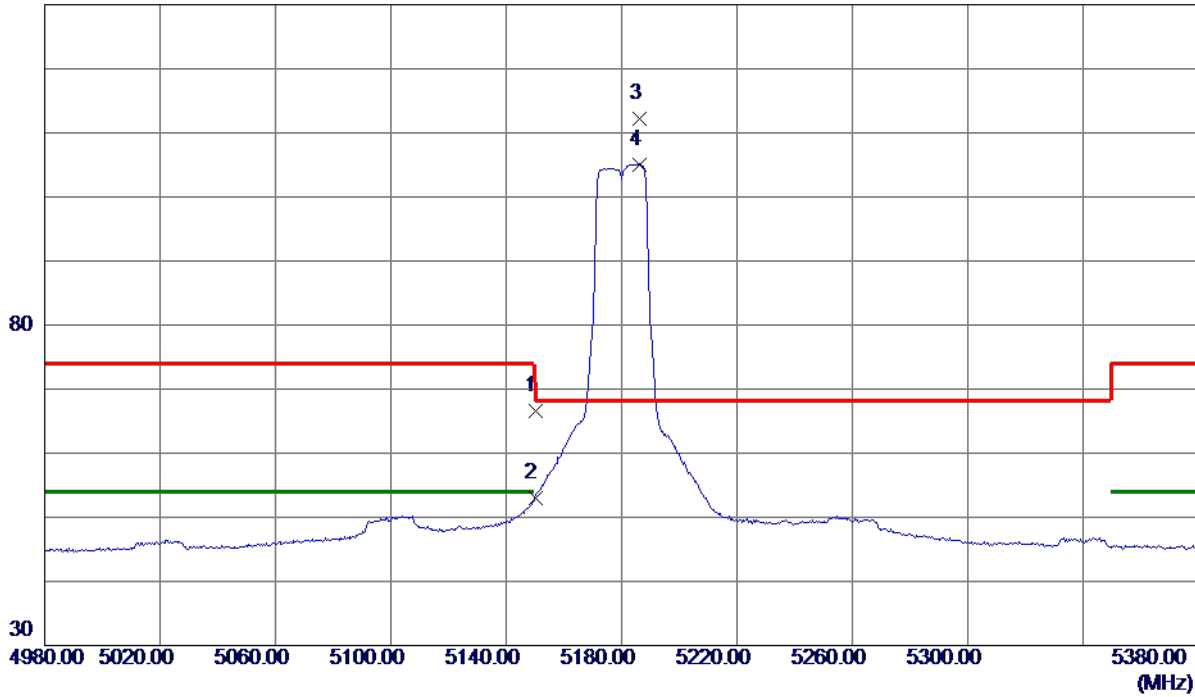

No.	Freq. MHz	Reading Level dBuV/m	Correct Factor dB	Measure ment dBuV/m	Limit dBuV/m	Margin dB	Detector	Comment
1	5150.0000	50.37	16.16	66.53	74.00	-7.47	Peak	
2	5150.0000	36.76	16.16	52.92	54.00	-1.08	AVG	
3 *	5186.4000	95.94	16.24	112.18	68.30	43.88	Peak	No Limit
4	5186.4000	88.86	16.24	105.10	999.00	-893.90	AVG	No Limit

REMARKS:

- (1) Measurement Value = Reading Level + Correct Factor.
- (2) Margin Level = Measurement Value - Limit Value.

Orthogonal Axis	X
Test Mode	UNII-1_TX A Mode 5180 MHz

Vertical

80 dBuV/m

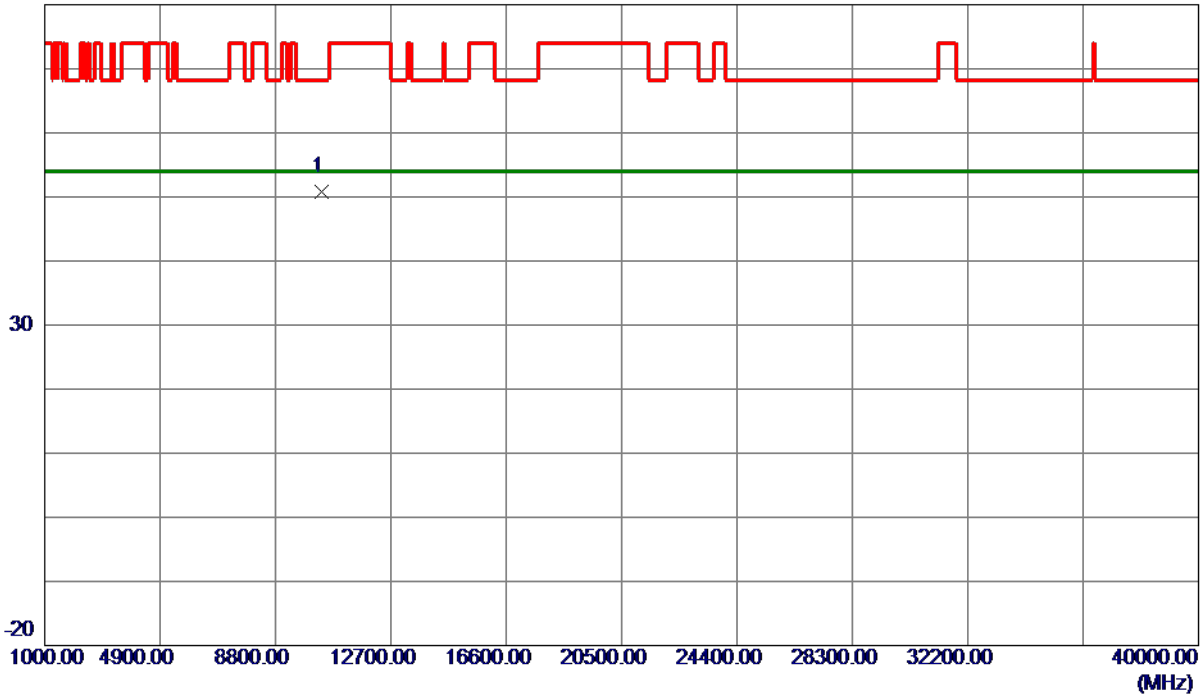

No.	Freq. MHz	Reading Level dBuV/m	Correct Factor dB	Measure ment dBuV/m	Limit dBuV/m	Margin dB	Detector	Comment
1 *	10359.4900	37.28	13.51	50.79	68.30	-17.51	Peak	

REMARKS:

- (1) Measurement Value = Reading Level + Correct Factor.
- (2) Margin Level = Measurement Value - Limit Value.

Orthogonal Axis	X
Test Mode	UNII-1_TX A Mode 5180 MHz

Horizontal

130 dBuV/m

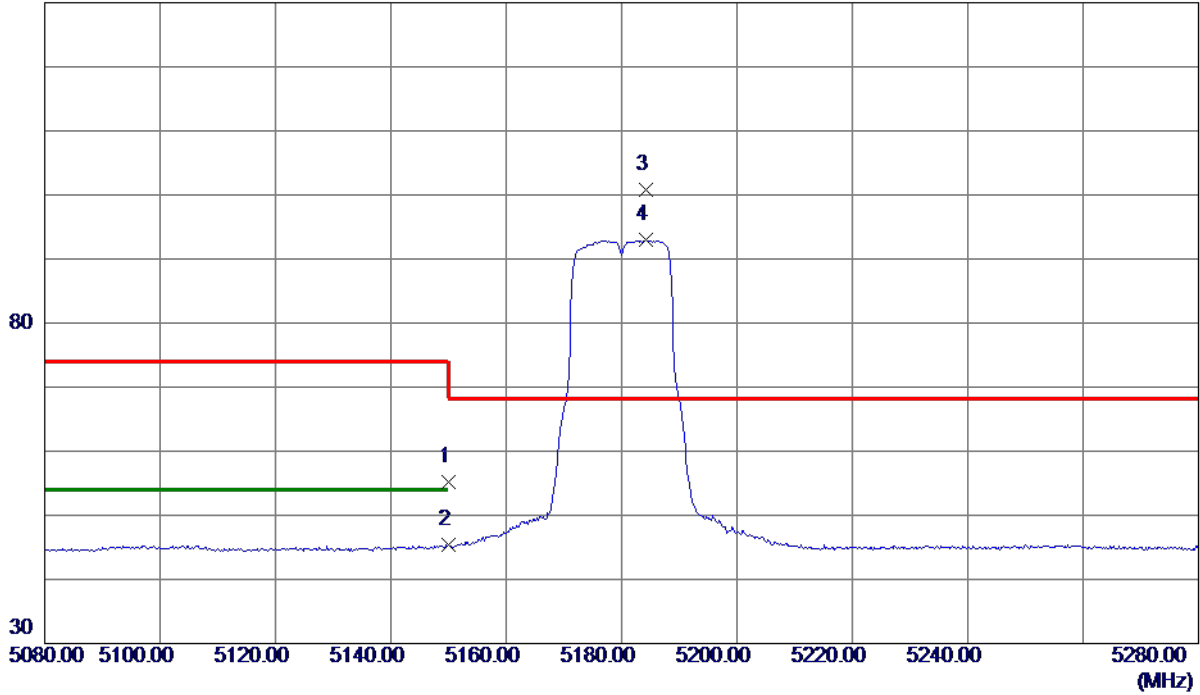

No.	Freq. MHz	Reading Level dBuV/m	Correct Factor dB	Measure ment dBuV/m	Limit dBuV/m	Margin dB	Detector	Comment
1	5150.0000	38.98	16.16	55.14	74.00	-18.86	Peak	
2	5150.0000	29.20	16.16	45.36	54.00	-8.64	AVG	
3 *	5184.2000	84.60	16.24	100.84	68.30	32.54	Peak	No Limit
4	5184.2000	76.67	16.24	92.91	999.00	-906.09	AVG	No Limit

REMARKS:

- (1) Measurement Value = Reading Level + Correct Factor.
- (2) Margin Level = Measurement Value - Limit Value.

Orthogonal Axis	X
Test Mode	UNII-1_TX A Mode 5180 MHz

Horizontal

80 dBuV/m

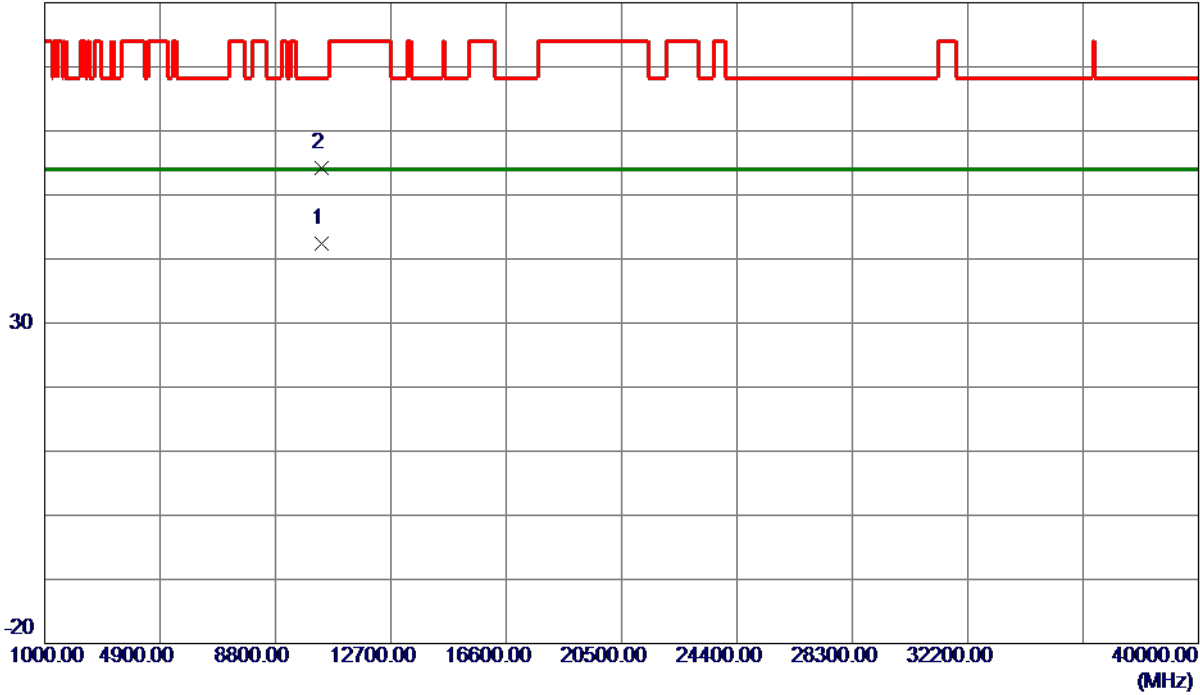

No.	Freq. MHz	Reading Level dBuV/m	Correct Factor dB	Measure ment dBuV/m	Limit dBuV/m	Margin dB	Detector	Comment
1 *	10361.3800	28.87	13.52	42.39	54.00	-11.61	AVG	
2	10363.7500	40.65	13.52	54.17	68.30	-14.13	Peak	

REMARKS:

- (1) Measurement Value = Reading Level + Correct Factor.
- (2) Margin Level = Measurement Value - Limit Value.

Orthogonal Axis	X
Test Mode	UNII-1_TX A Mode 5200 MHz

Vertical

130 dBuV/m

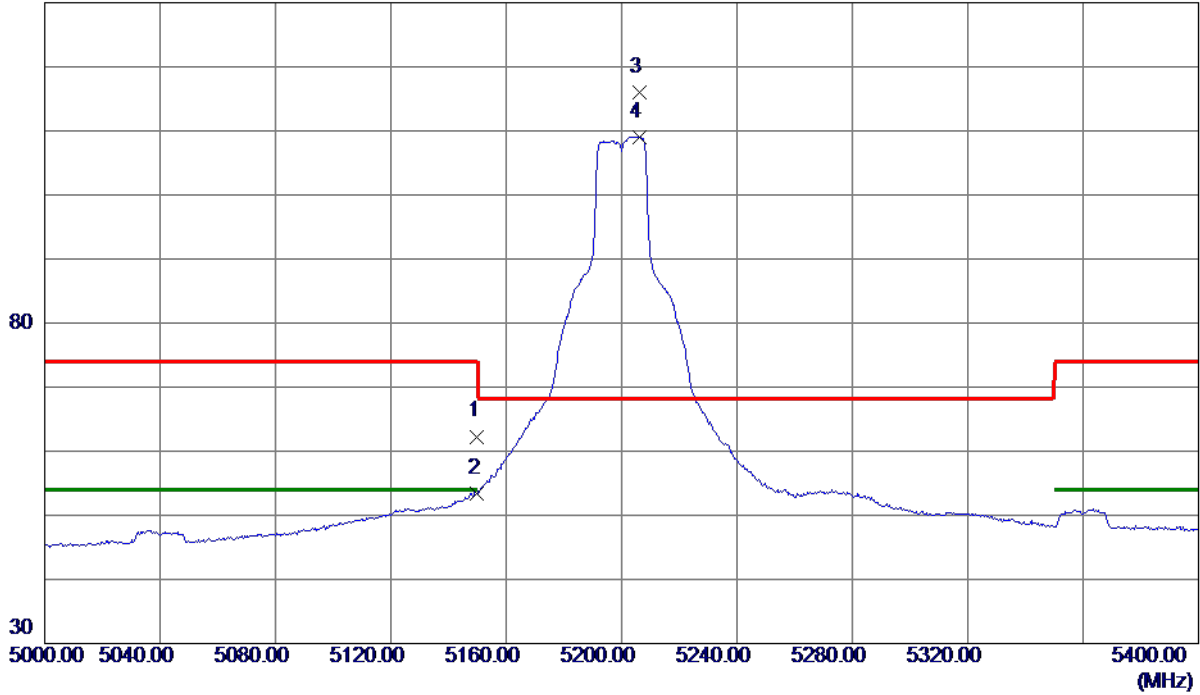

No.	Freq. MHz	Reading Level dBuV/m	Correct Factor dB	Measure ment dBuV/m	Limit dBuV/m	Margin dB	Detector	Comment
1	5150.0000	46.14	16.16	62.30	74.00	-11.70	Peak	
2	5150.0000	37.26	16.16	53.42	54.00	-0.58	AVG	
3 *	5206.4000	99.76	16.29	116.05	68.30	47.75	Peak	No Limit
4	5206.4000	92.80	16.29	109.09	999.00	-889.91	AVG	No Limit

REMARKS:

- (1) Measurement Value = Reading Level + Correct Factor.
- (2) Margin Level = Measurement Value - Limit Value.

Orthogonal Axis	X
Test Mode	UNII-1_TX A Mode 5200 MHz

Vertical

80 dBuV/m

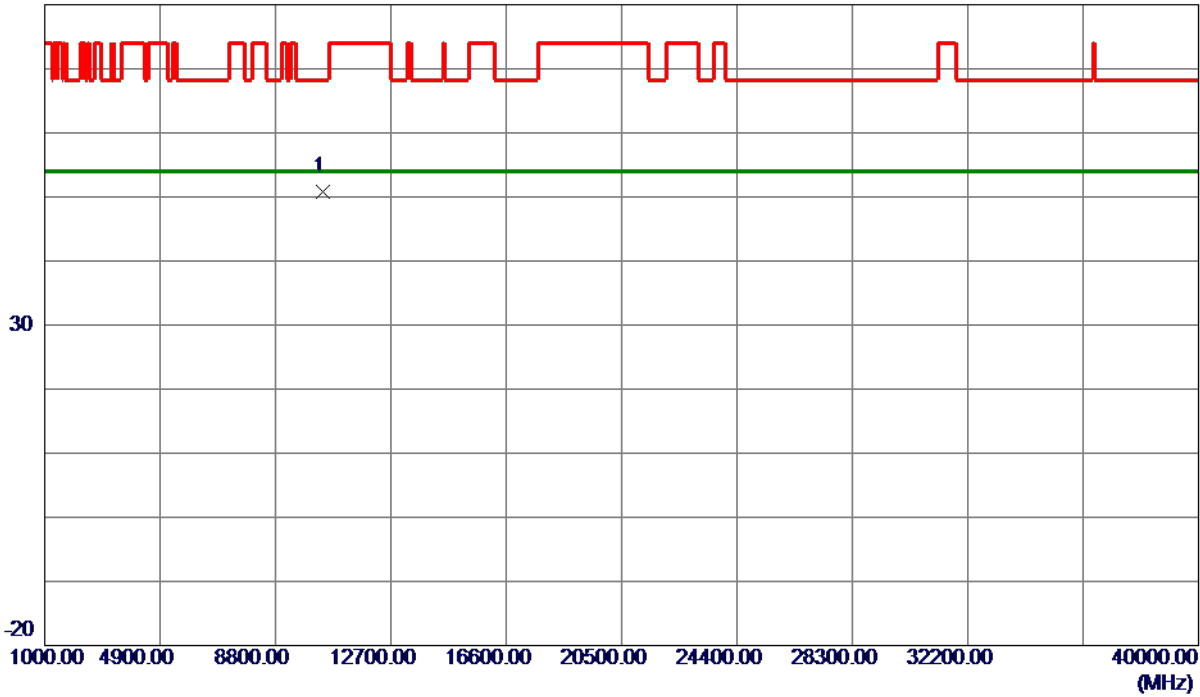

No.	Freq. MHz	Reading Level dBuV/m	Correct Factor dB	Measure ment dBuV/m	Limit dBuV/m	Margin dB	Detector	Comment
1 *	10401.8200	37.28	13.55	50.83	68.30	-17.47	Peak	

REMARKS:

- (1) Measurement Value = Reading Level + Correct Factor.
- (2) Margin Level = Measurement Value - Limit Value.

Orthogonal Axis	X
Test Mode	UNII-1_TX A Mode 5200 MHz

Horizontal

130 dBuV/m

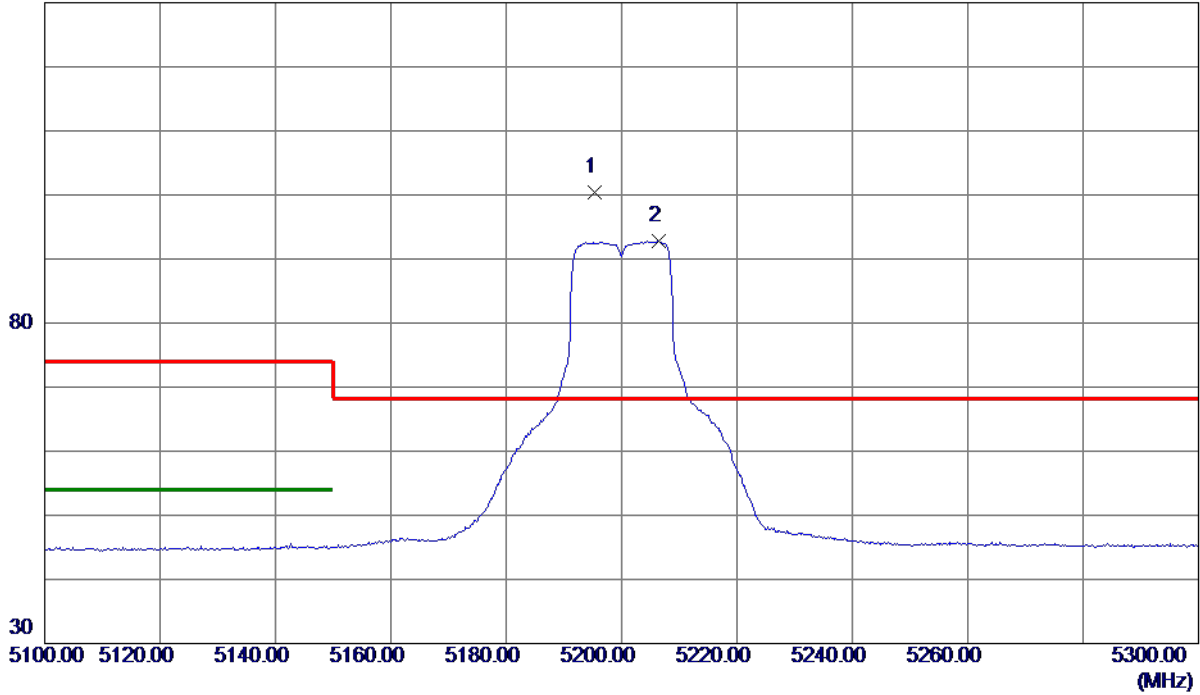

No.	Freq. MHz	Reading Level dBuV/m	Correct Factor dB	Measure ment dBuV/m	Limit dBuV/m	Margin dB	Detector	Comment
1 *	5195.4000	84.11	16.26	100.37	68.30	32.07	Peak	No Limit
2	5206.4000	76.46	16.29	92.75	999.00	-906.25	AVG	No Limit

REMARKS:

- (1) Measurement Value = Reading Level + Correct Factor.
- (2) Margin Level = Measurement Value - Limit Value.

Orthogonal Axis	X
Test Mode	UNII-1_TX A Mode 5200 MHz

Horizontal

80 dBuV/m

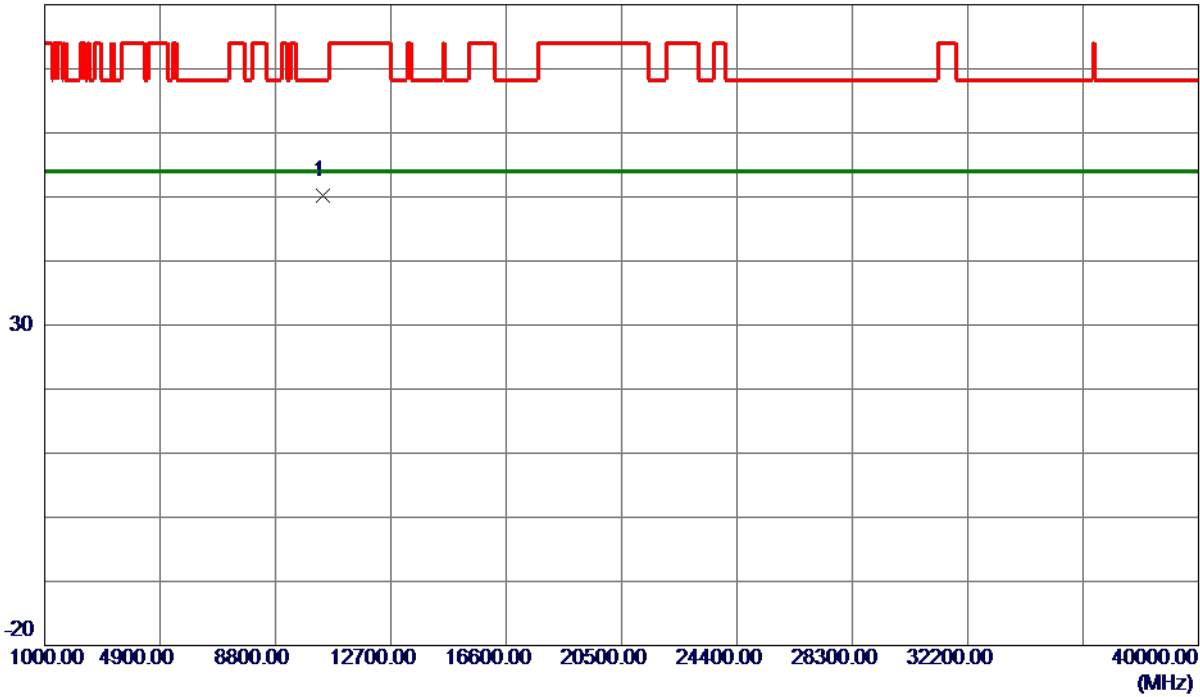

No.	Freq. MHz	Reading Level dBuV/m	Correct Factor dB	Measure ment dBuV/m	Limit dBuV/m	Margin dB	Detector	Comment
1 *	10397.2100	36.65	13.55	50.20	68.30	-18.10	Peak	

REMARKS:

- (1) Measurement Value = Reading Level + Correct Factor.
- (2) Margin Level = Measurement Value - Limit Value.

Orthogonal Axis	X
Test Mode	UNII-1_TX A Mode 5240 MHz

Vertical

130 dBuV/m

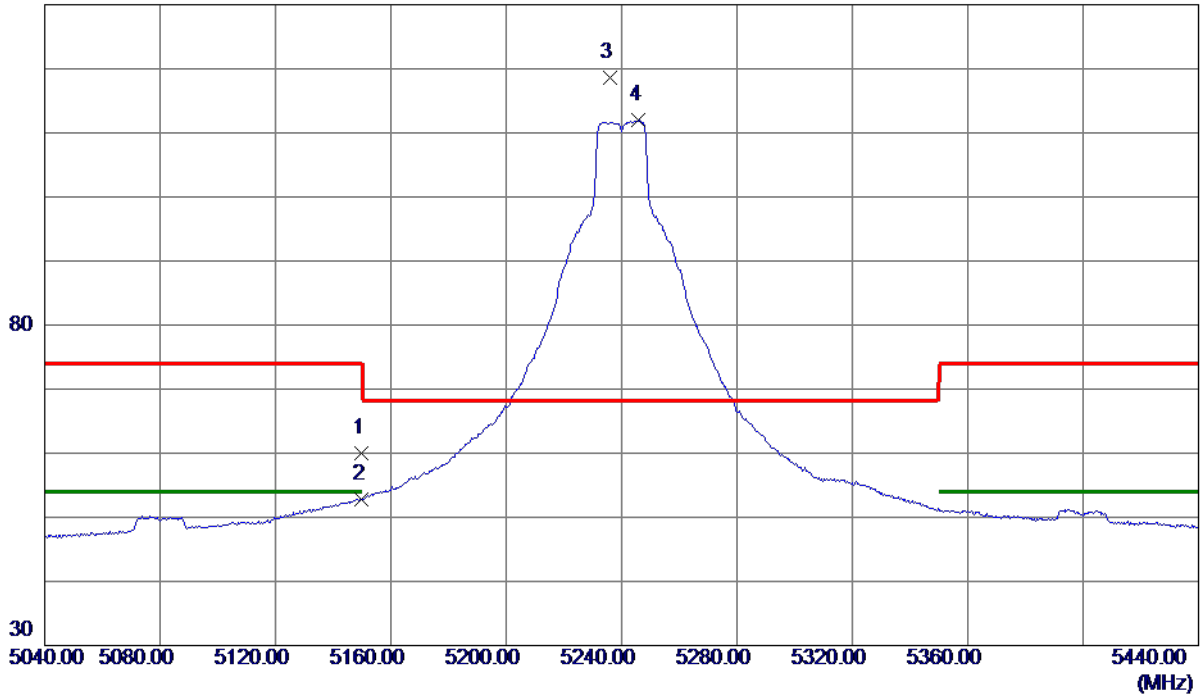

No.	Freq. MHz	Reading Level dBuV/m	Correct Factor dB	Measure ment dBuV/m	Limit dBuV/m	Margin dB	Detector	Comment
1	5150.0000	43.75	16.16	59.91	74.00	-14.09	Peak	
2	5150.0000	36.72	16.16	52.88	54.00	-1.12	AVG	
3 *	5236.0000	102.27	16.36	118.63	68.30	50.33	Peak	No Limit
4	5246.0000	95.57	16.38	111.95	999.00	-887.05	AVG	No Limit

REMARKS:

- (1) Measurement Value = Reading Level + Correct Factor.
- (2) Margin Level = Measurement Value - Limit Value.

Orthogonal Axis	X
Test Mode	UNII-1_TX A Mode 5240 MHz

Vertical

80 dBuV/m

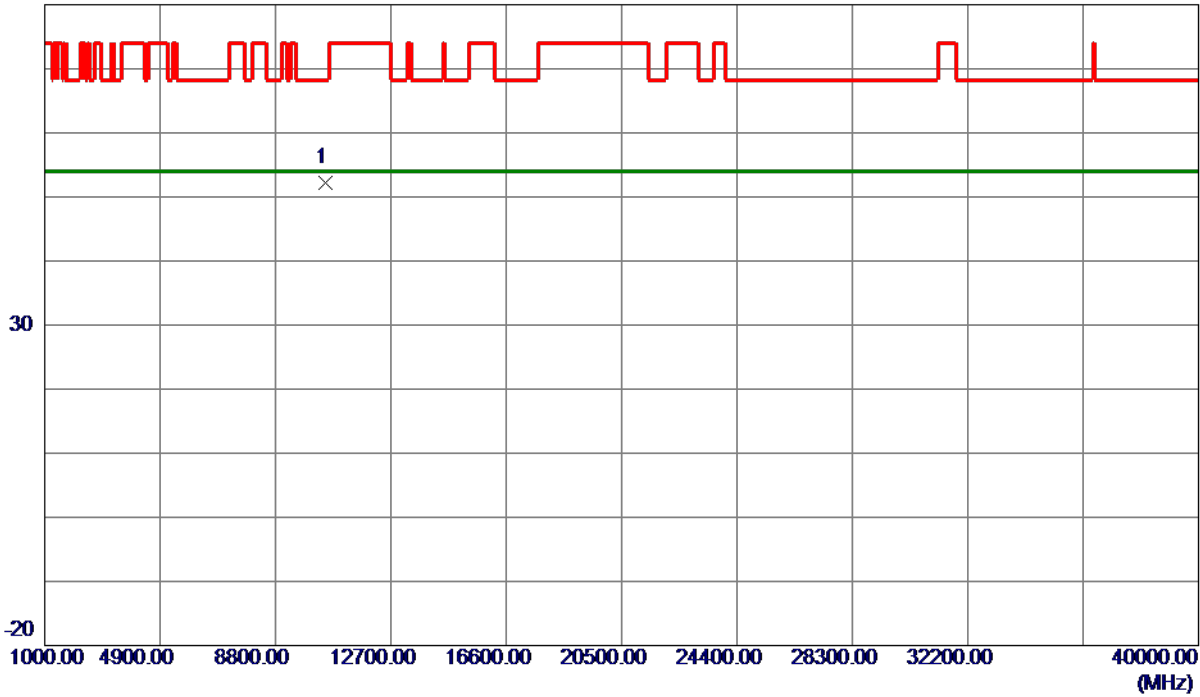

No.	Freq. MHz	Reading Level dBuV/m	Correct Factor dB	Measure ment dBuV/m	Limit dBuV/m	Margin dB	Detector	Comment
1 *	10482.1650	38.48	13.63	52.11	68.30	-16.19	Peak	

REMARKS:

- (1) Measurement Value = Reading Level + Correct Factor.
- (2) Margin Level = Measurement Value - Limit Value.

Orthogonal Axis	X
Test Mode	UNII-1_TX A Mode 5240 MHz

Horizontal

130 dBuV/m

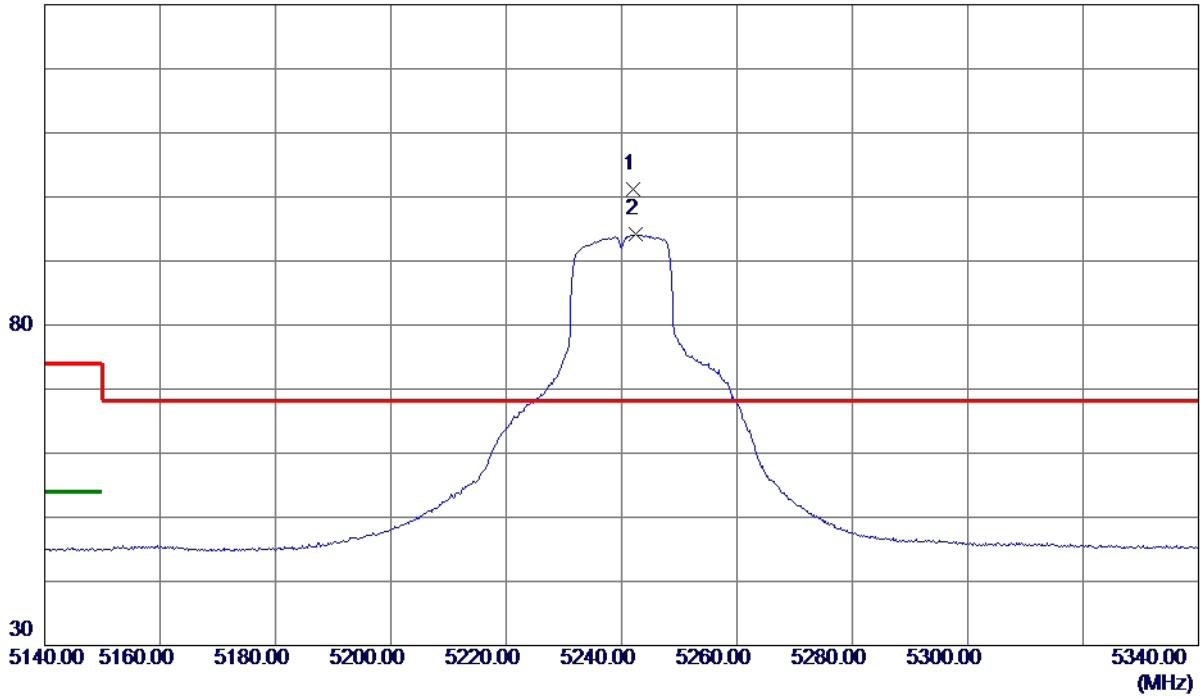

No.	Freq. MHz	Reading Level dBuV/m	Correct Factor dB	Measure ment dBuV/m	Limit dBuV/m	Margin dB	Detector	Comment
1 *	5242.0000	84.74	16.37	101.11	68.30	32.81	Peak	No Limit
2	5242.4000	77.75	16.37	94.12	999.00	-904.88	AVG	No Limit

REMARKS:

- (1) Measurement Value = Reading Level + Correct Factor.
- (2) Margin Level = Measurement Value - Limit Value.

Orthogonal Axis	X
Test Mode	UNII-1_TX A Mode 5240 MHz

Horizontal

80 dBuV/m

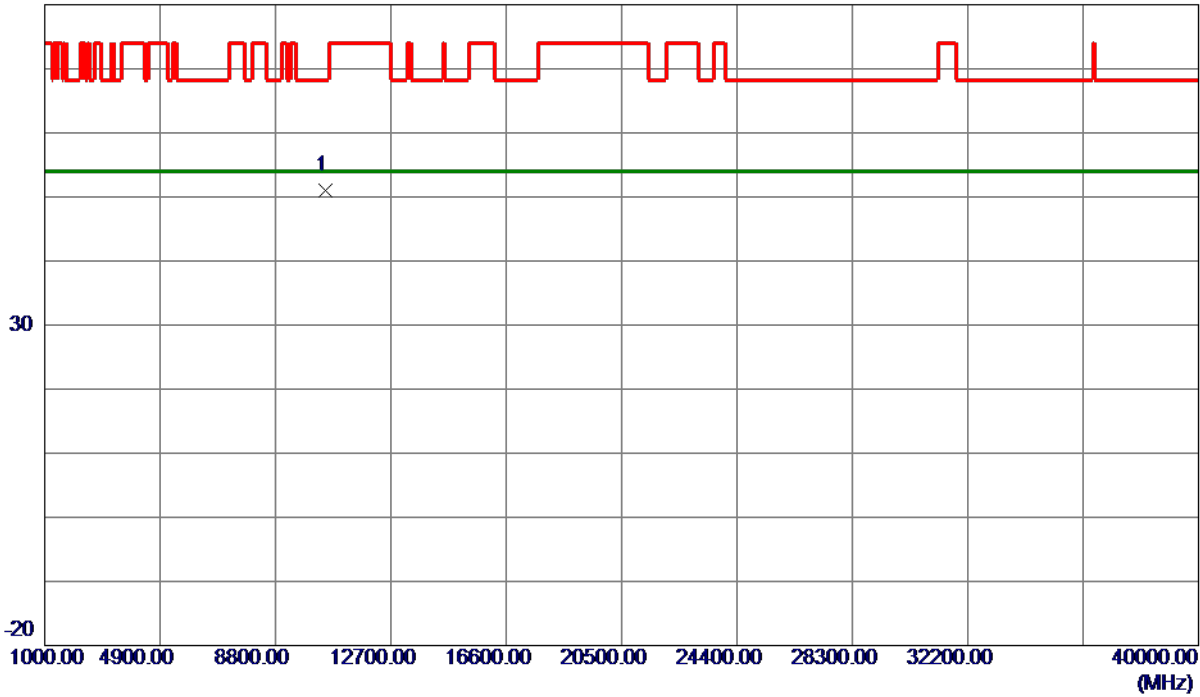

No.	Freq. MHz	Reading Level dBuV/m	Correct Factor dB	Measure ment dBuV/m	Limit dBuV/m	Margin dB	Detector	Comment
1 *	10480.8350	37.39	13.63	51.02	68.30	-17.28	Peak	

REMARKS:

- (1) Measurement Value = Reading Level + Correct Factor.
- (2) Margin Level = Measurement Value - Limit Value.

Orthogonal Axis	X
Test Mode	UNII-2A_TX A Mode 5260 MHz

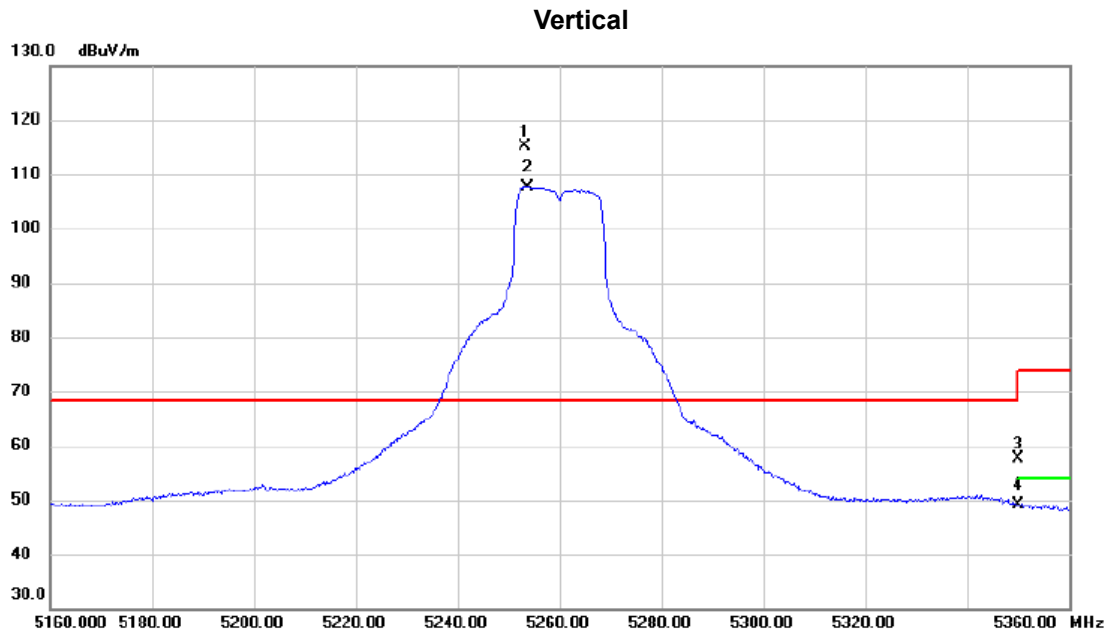

No.	Mk.	Freq. MHz	Reading Level dBuV	Correct Factor dB	Measure- ment dBuV/m	Limit dBuV/m	Margin dB	Detector	Comment
1	*	5253.200	98.75	16.41	115.16	68.30	46.86	peak	No Limit
2	X	5253.800	91.18	16.41	107.59	68.30	39.29	AVG	No Limit
3		5350.000	41.00	16.63	57.63	74.00	-16.37	peak	
4		5350.000	32.57	16.63	49.20	54.00	-4.80	AVG	

REMARKS:

- (1) Measurement Value = Reading Level + Correct Factor.
- (2) Margin Level = Measurement Value - Limit Value.

Orthogonal Axis	X
Test Mode	UNII-2A_TX A Mode 5260 MHz

Vertical

80 dBuV/m

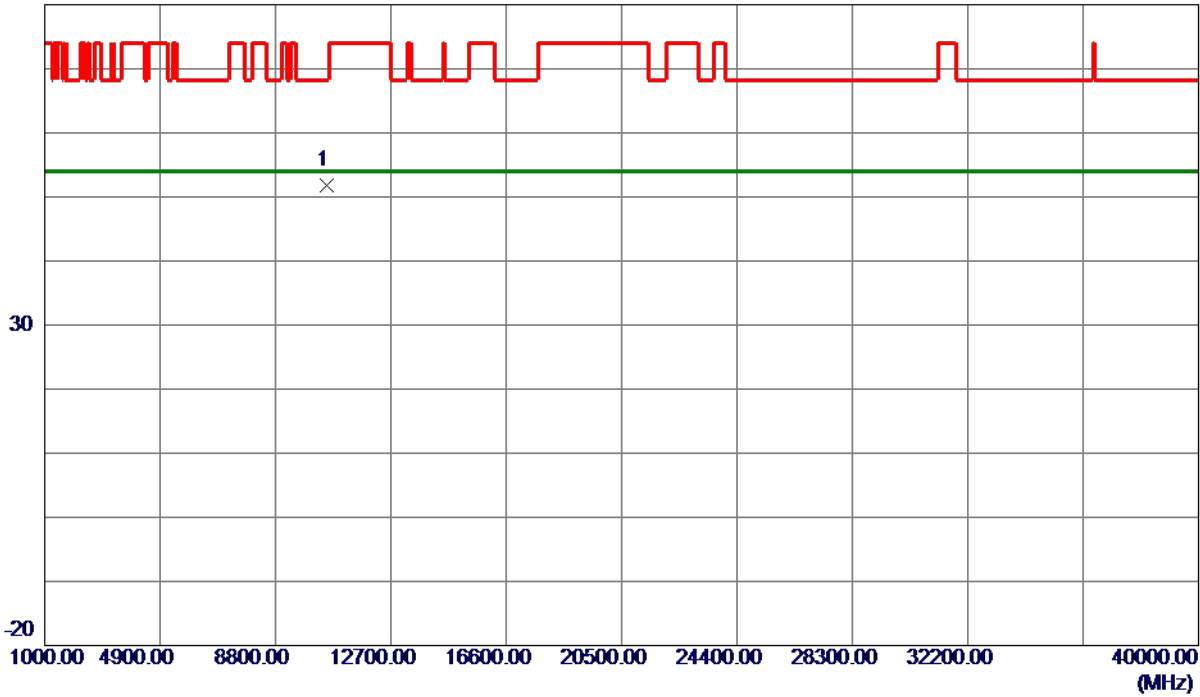

No.	Freq. MHz	Reading Level dBuV/m	Correct Factor dB	Measure ment dBuV/m	Limit dBuV/m	Margin dB	Detector	Comment
1 *	10519.2699	38.18	13.66	51.84	68.30	-16.46	Peak	

REMARKS:

- (1) Measurement Value = Reading Level + Correct Factor.
- (2) Margin Level = Measurement Value - Limit Value.

Orthogonal Axis	X
Test Mode	UNII-2A_TX A Mode 5260 MHz

Horizontal

130 dBuV/m

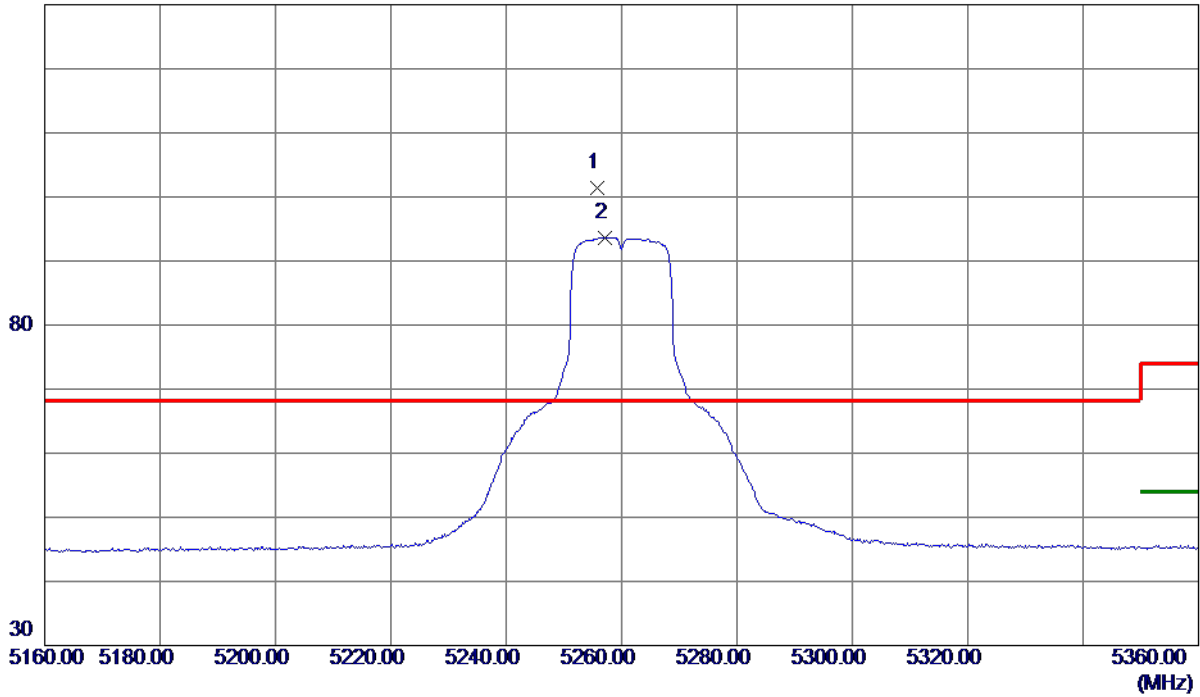

No.	Freq. MHz	Reading Level dBuV/m	Correct Factor dB	Measure ment dBuV/m	Limit dBuV/m	Margin dB	Detector	Comment
1 *	5255.8000	84.95	16.41	101.36	68.30	33.06	Peak	No Limit
2	5257.2000	77.26	16.41	93.67	999.00	-905.33	AVG	No Limit

REMARKS:

- (1) Measurement Value = Reading Level + Correct Factor.
- (2) Margin Level = Measurement Value - Limit Value.

Orthogonal Axis	X
Test Mode	UNII-2A_TX A Mode 5260 MHz

Horizontal

80 dBuV/m

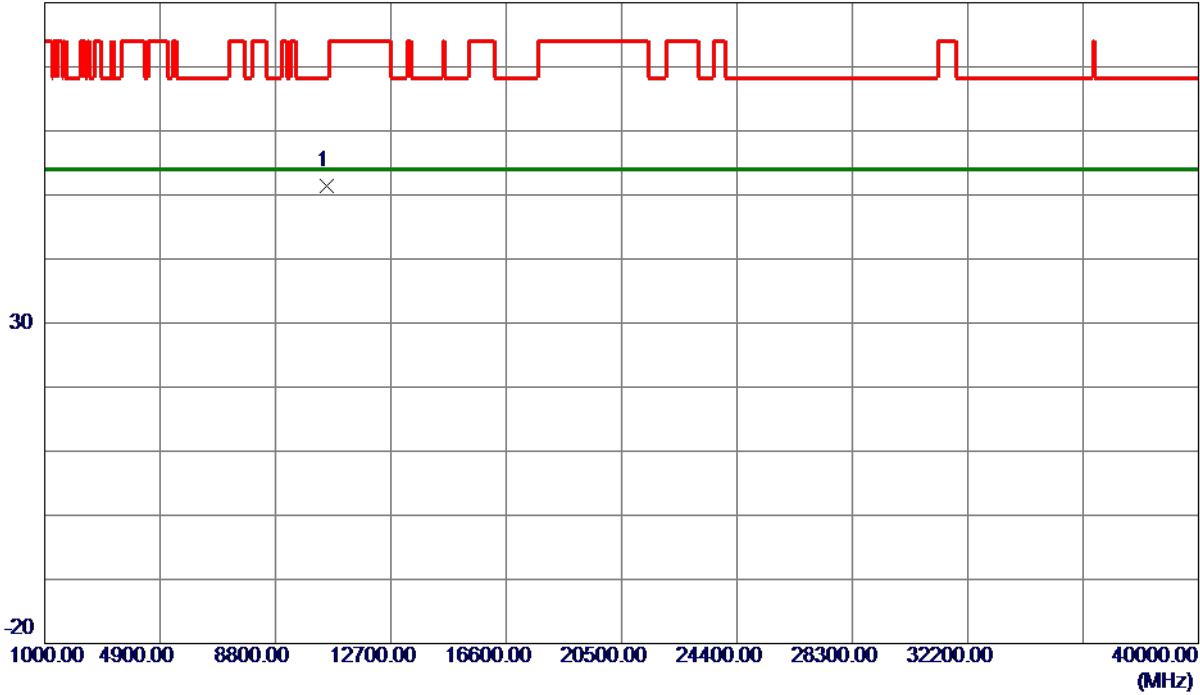

No.	Freq. MHz	Reading Level dBuV/m	Correct Factor dB	Measure ment dBuV/m	Limit dBuV/m	Margin dB	Detector	Comment
1 *	10521.1100	37.82	13.66	51.48	68.30	-16.82	Peak	

REMARKS:

- (1) Measurement Value = Reading Level + Correct Factor.
- (2) Margin Level = Measurement Value - Limit Value.

Orthogonal Axis	X
Test Mode	UNII-2A_TX A Mode 5300 MHz

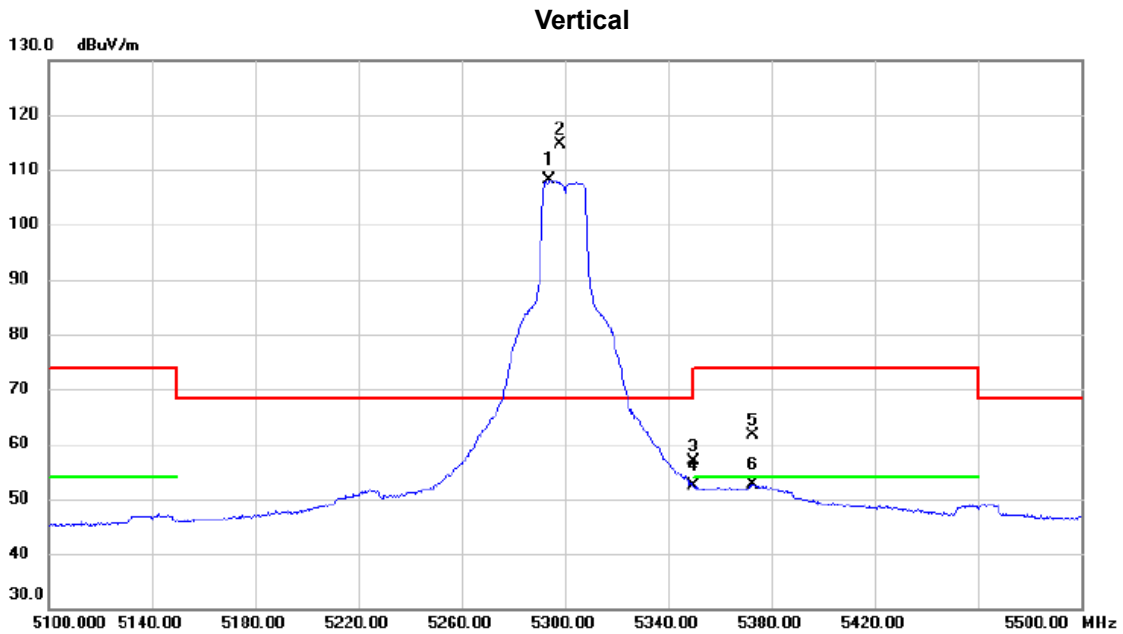

No.	Mk.	Freq. MHz	Reading Level dBuV	Correct Factor dB	Measure- ment dBuV/m	Limit dBuV/m	Margin dB	Detector	Comment
1	X	5294.000	91.58	16.50	108.08	68.30	39.78	AVG	No Limit
2	*	5298.000	98.16	16.51	114.67	68.30	46.37	peak	No Limit
3		5350.000	40.27	16.63	56.90	74.00	-17.10	peak	
4		5350.000	35.75	16.63	52.38	54.00	-1.62	AVG	
5		5372.800	45.07	16.68	61.75	74.00	-12.25	peak	
6		5372.800	35.92	16.68	52.60	54.00	-1.40	AVG	

REMARKS:

- (1) Measurement Value = Reading Level + Correct Factor.
- (2) Margin Level = Measurement Value - Limit Value.

Orthogonal Axis	X
Test Mode	UNII-2A_TX A Mode 5300 MHz

Vertical

80 dBuV/m

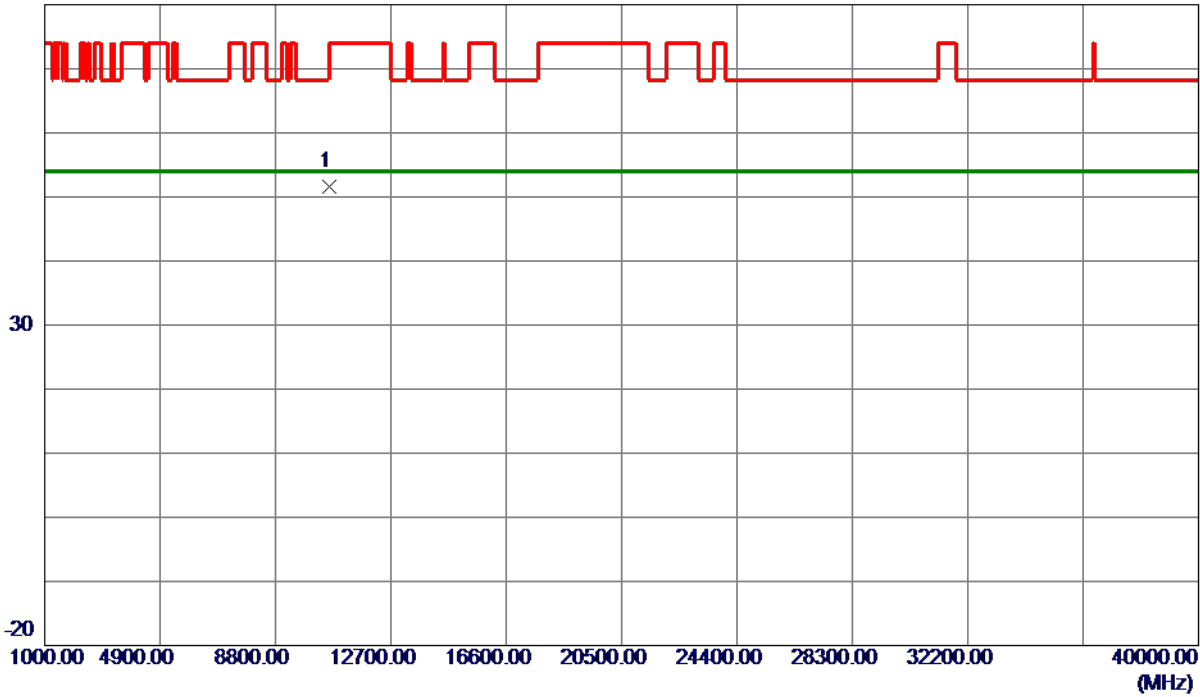

No.	Freq. MHz	Reading Level dBuV/m	Correct Factor dB	Measure ment dBuV/m	Limit dBuV/m	Margin dB	Detector	Comment
1 *	10602.0950	37.93	13.70	51.63	74.00	-22.37	Peak	

REMARKS:

- (1) Measurement Value = Reading Level + Correct Factor.
- (2) Margin Level = Measurement Value - Limit Value.

Orthogonal Axis	X
Test Mode	UNII-2A_TX A Mode 5300 MHz

Horizontal

130 dBuV/m

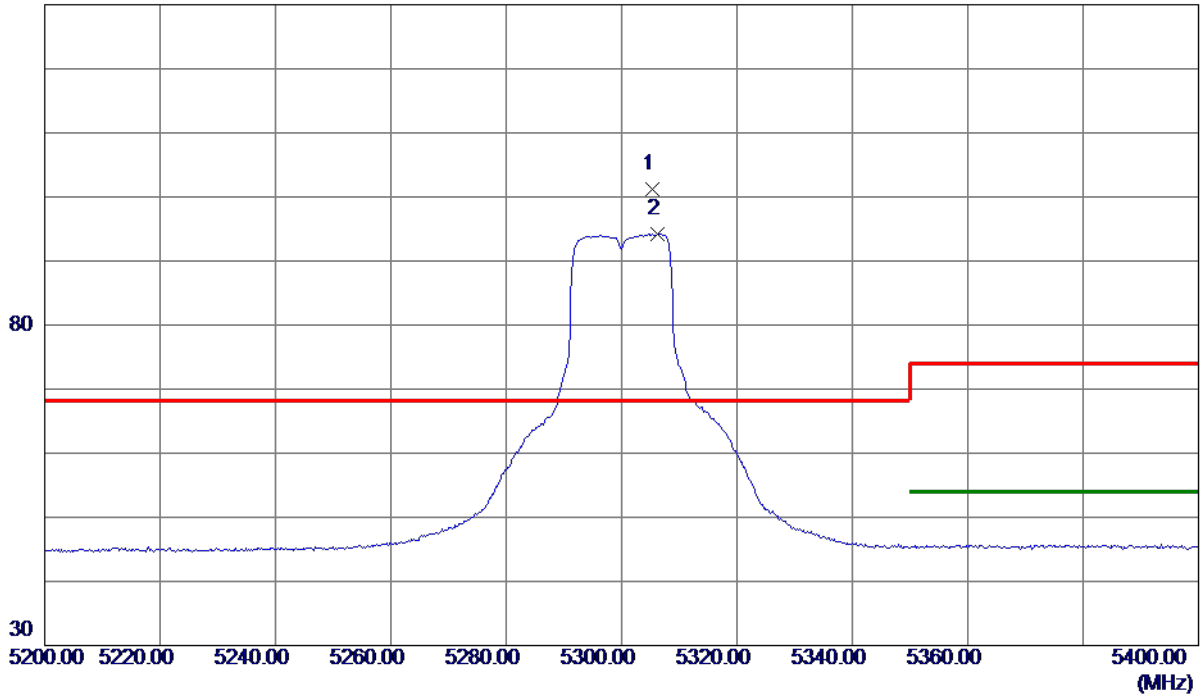

No.	Freq. MHz	Reading Level dBuV/m	Correct Factor dB	Measure ment dBuV/m	Limit dBuV/m	Margin dB	Detector	Comment
1 *	5305.4000	84.70	16.52	101.22	68.30	32.92	Peak	No Limit
2	5306.2000	77.72	16.53	94.25	999.00	-904.75	AVG	No Limit

REMARKS:

- (1) Measurement Value = Reading Level + Correct Factor.
- (2) Margin Level = Measurement Value - Limit Value.

Orthogonal Axis	X
Test Mode	UNII-2A_TX A Mode 5300 MHz

Horizontal

80 dBuV/m

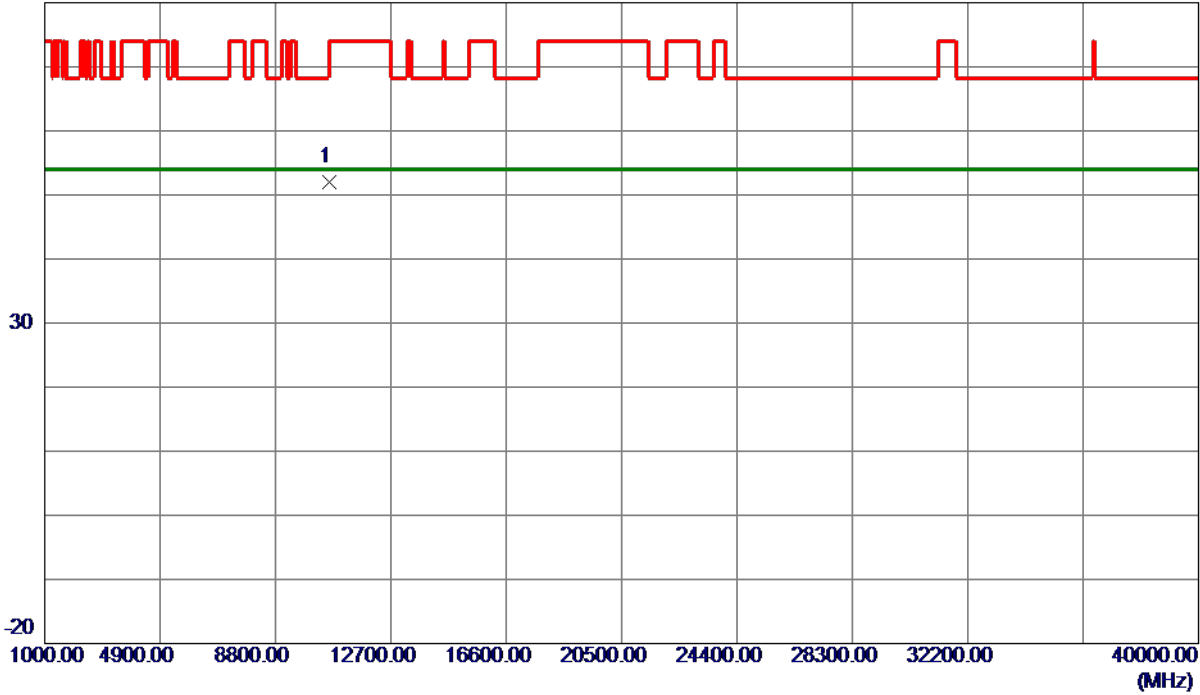

No.	Freq. MHz	Reading Level dBuV/m	Correct Factor dB	Measure ment dBuV/m	Limit dBuV/m	Margin dB	Detector	Comment
1 *	10598.8850	38.24	13.70	51.94	68.30	-16.36	Peak	

REMARKS:

- (1) Measurement Value = Reading Level + Correct Factor.
- (2) Margin Level = Measurement Value - Limit Value.

Orthogonal Axis	X
Test Mode	UNII-2A_TX A Mode 5320 MHz

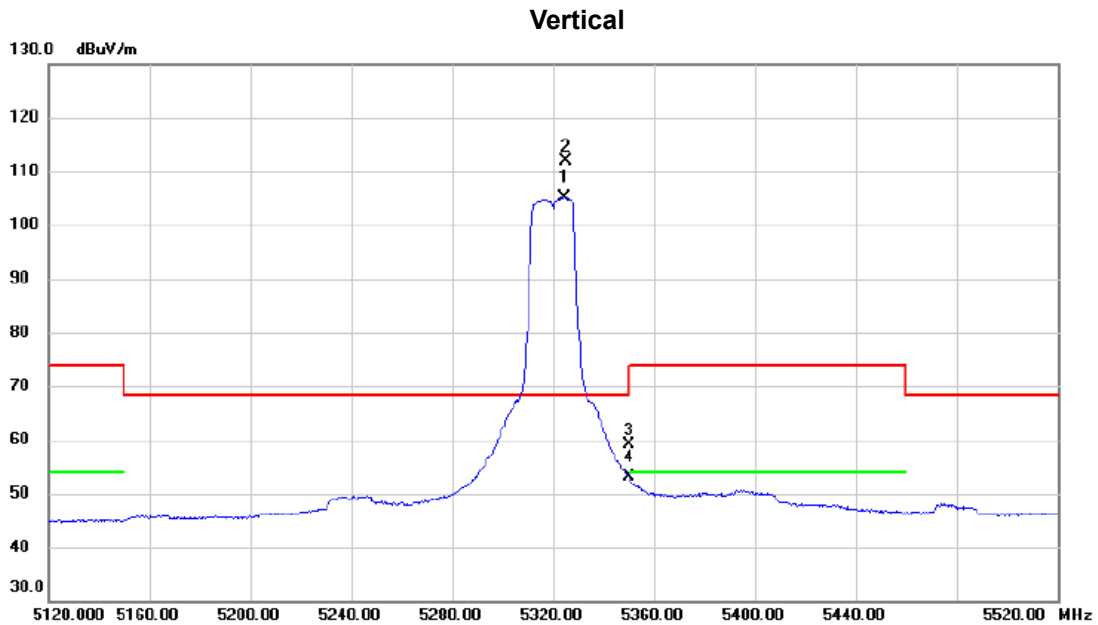

No.	Mk.	Freq. MHz	Reading Level dBuV	Correct Factor dB	Measure- ment dBuV/m	Limit dBuV/m	Margin dB	Detector	Comment
1	X	5324.400	88.48	16.56	105.04	68.30	36.74	AVG	No Limit
2	*	5324.800	95.39	16.56	111.95	68.30	43.65	peak	No Limit
3		5350.000	42.60	16.63	59.23	74.00	-14.77	peak	
4		5350.000	36.49	16.63	53.12	54.00	-0.88	AVG	

REMARKS:

- (1) Measurement Value = Reading Level + Correct Factor.
- (2) Margin Level = Measurement Value - Limit Value.

Orthogonal Axis	X
Test Mode	UNII-2A_TX A Mode 5320 MHz

Vertical

80 dBuV/m



No.	Freq. MHz	Reading Level dBuV/m	Correct Factor dB	Measure ment dBuV/m	Limit dBuV/m	Margin dB	Detector	Comment
1 *	10639.7650	38.46	13.72	52.18	74.00	-21.82	Peak	

REMARKS:

- (1) Measurement Value = Reading Level + Correct Factor.
- (2) Margin Level = Measurement Value - Limit Value.

Orthogonal Axis	X
Test Mode	UNII-2A_TX A Mode 5320 MHz

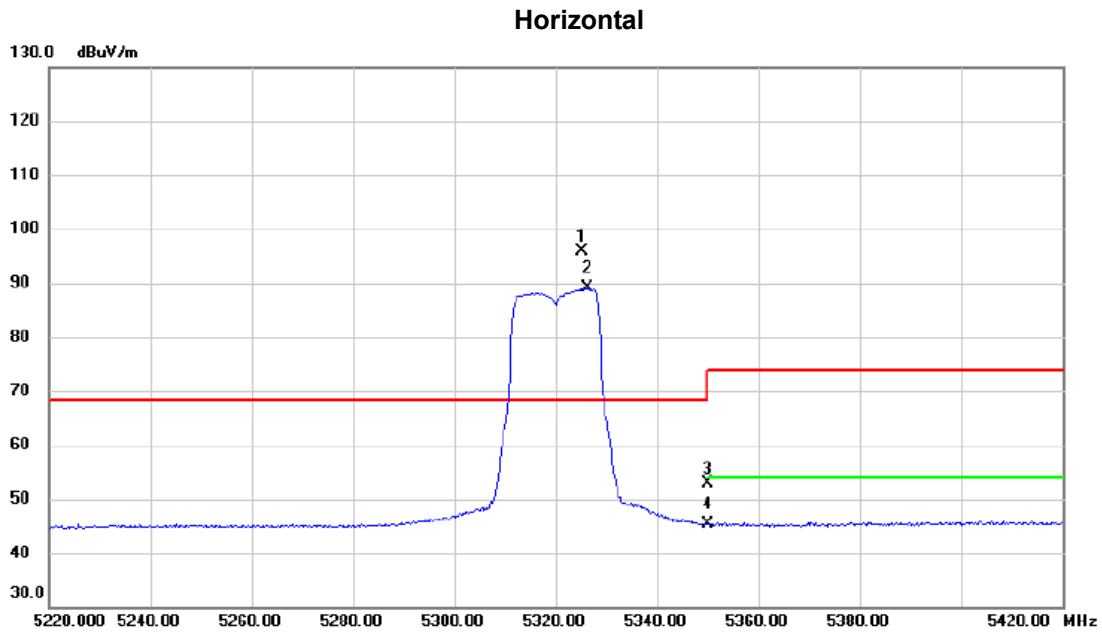

No.	Mk.	Freq. MHz	Reading Level dBuV	Correct Factor dB	Measure- ment dBuV/m	Limit dBuV/m	Margin dB	Detector	Comment
1	*	5325.200	79.43	16.57	96.00	68.30	27.70	peak	No Limit
2	X	5326.200	72.45	16.57	89.02	68.30	20.72	AVG	No Limit
3		5350.000	36.26	16.63	52.89	74.00	-21.11	peak	
4		5350.000	28.78	16.63	45.41	54.00	-8.59	AVG	

REMARKS:

- (1) Measurement Value = Reading Level + Correct Factor.
- (2) Margin Level = Measurement Value - Limit Value.

Orthogonal Axis	X
Test Mode	UNII-2A_TX A Mode 5320 MHz

Horizontal

80 dBuV/m

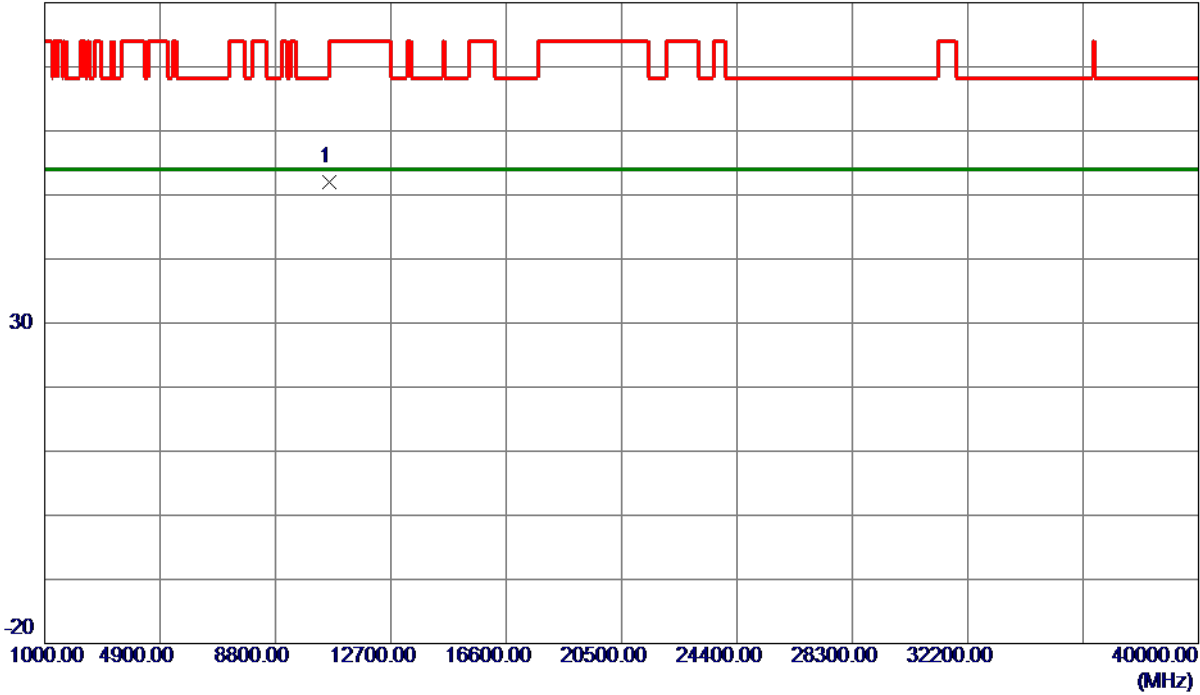

No.	Freq. MHz	Reading Level dBuV/m	Correct Factor dB	Measure ment dBuV/m	Limit dBuV/m	Margin dB	Detector	Comment
1 *	10640.4300	38.27	13.72	51.99	74.00	-22.01	Peak	

REMARKS:

- (1) Measurement Value = Reading Level + Correct Factor.
- (2) Margin Level = Measurement Value - Limit Value.

Orthogonal Axis	X
Test Mode	UNII-2C_TX A Mode 5500 MHz

Vertical

130 dBuV/m

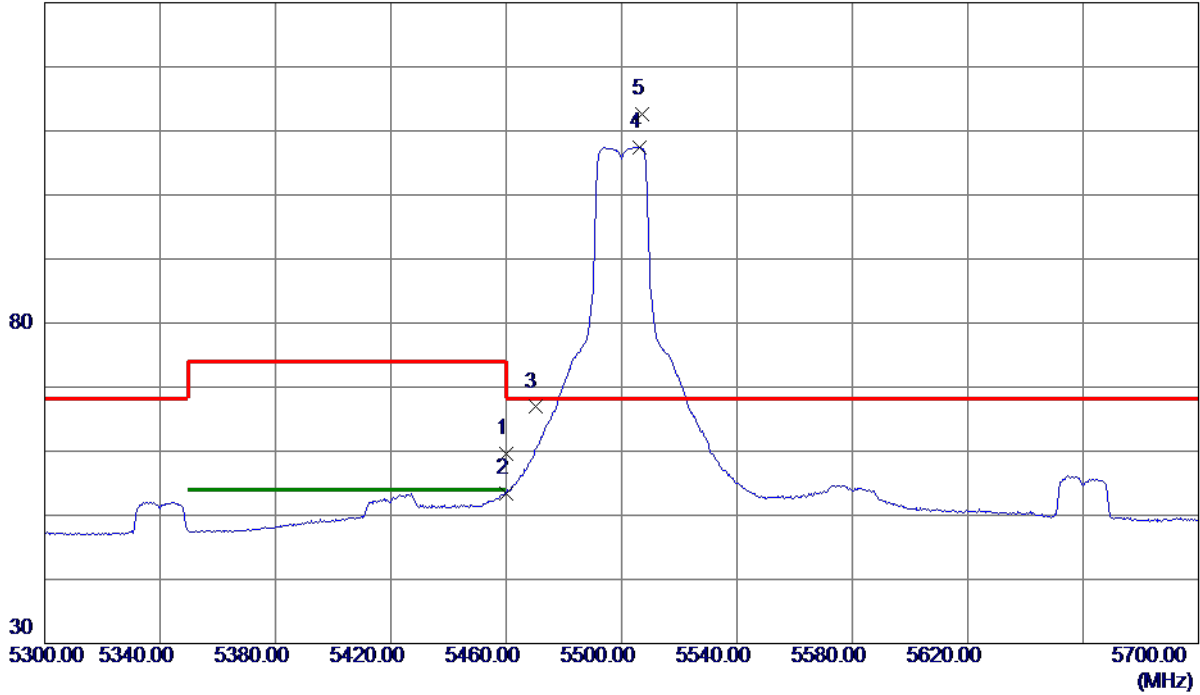

No.	Freq. MHz	Reading Level dBuV/m	Correct Factor dB	Measure ment dBuV/m	Limit dBuV/m	Margin dB	Detector	Comment
1	5460.0000	42.78	16.89	59.67	74.00	-14.33	Peak	
2	5460.0000	36.58	16.89	53.47	54.00	-0.53	AVG	
3	5470.0000	49.99	16.91	66.90	68.30	-1.40	Peak	
4	5506.4000	90.45	17.00	107.45	999.00	-891.55	AVG	No Limit
5 *	5507.2000	95.55	17.01	112.56	68.30	44.26	Peak	No Limit

REMARKS:

- (1) Measurement Value = Reading Level + Correct Factor.
- (2) Margin Level = Measurement Value - Limit Value.

Orthogonal Axis	X
Test Mode	UNII-2C_TX A Mode 5500 MHz

Vertical

80 dBuV/m

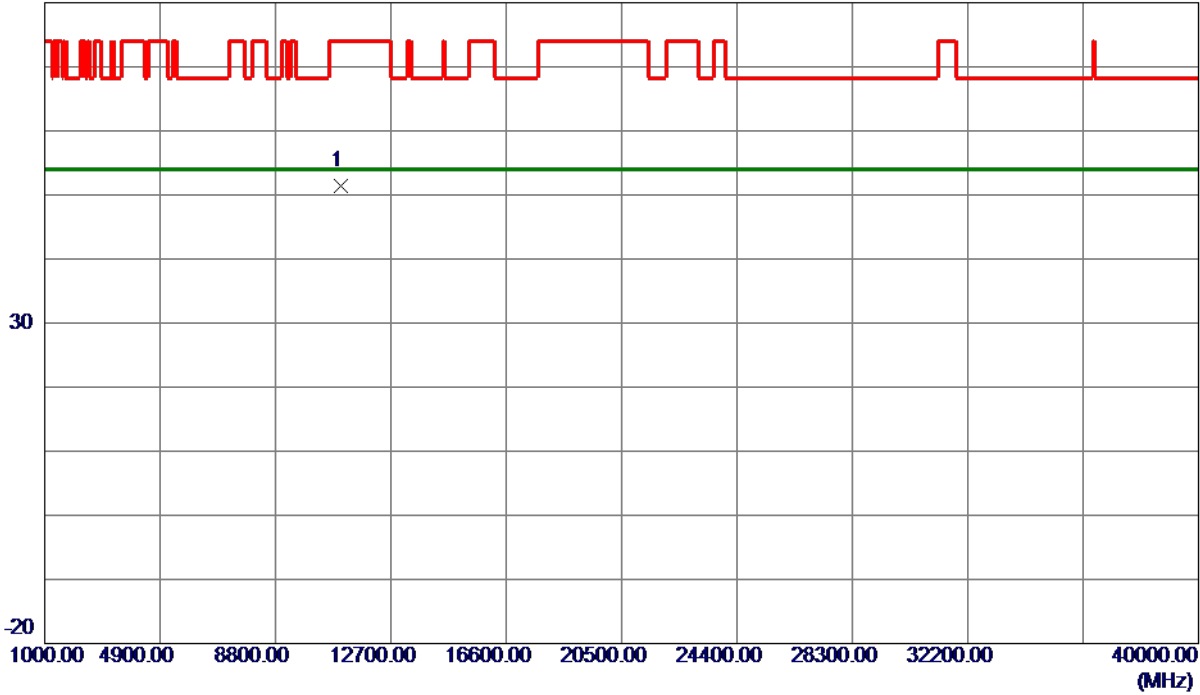

No.	Freq. MHz	Reading Level dBuV/m	Correct Factor dB	Measure ment dBuV/m	Limit dBuV/m	Margin dB	Detector	Comment
1 *	11000.1600	37.54	13.92	51.46	74.00	-22.54	Peak	

REMARKS:

- (1) Measurement Value = Reading Level + Correct Factor.
- (2) Margin Level = Measurement Value - Limit Value.

Orthogonal Axis	X
Test Mode	UNII-2C_TX A Mode 5500 MHz

Horizontal

130 dBuV/m

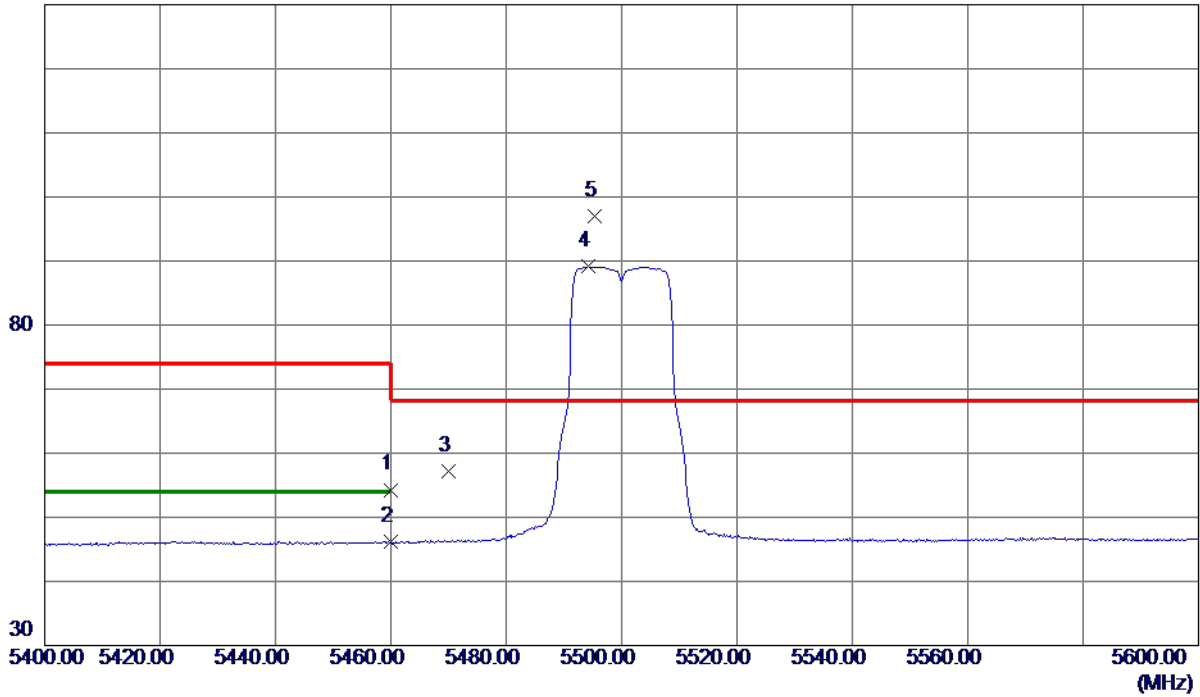

No.	Freq. MHz	Reading Level dBuV/m	Correct Factor dB	Measure ment dBuV/m	Limit dBuV/m	Margin dB	Detector	Comment
1	5460.0000	37.41	16.89	54.30	74.00	-19.70	Peak	
2	5460.0000	29.24	16.89	46.13	54.00	-7.87	AVG	
3	5470.0000	40.24	16.91	57.15	68.30	-11.15	Peak	
4	5494.2000	72.17	16.97	89.14	999.00	-909.86	AVG	No Limit
5 *	5495.4000	80.01	16.97	96.98	68.30	28.68	Peak	No Limit

REMARKS:

- (1) Measurement Value = Reading Level + Correct Factor.
- (2) Margin Level = Measurement Value - Limit Value.

Orthogonal Axis	X
Test Mode	UNII-2C_TX A Mode 5500 MHz

Horizontal

80 dBuV/m

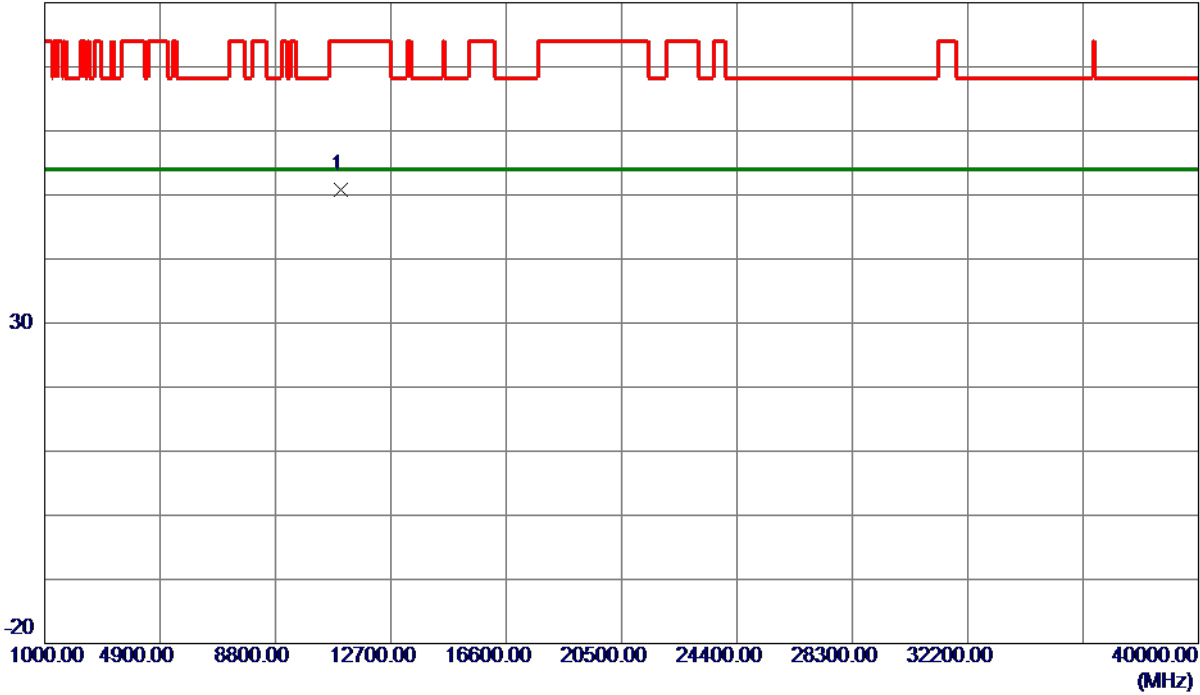

No.	Freq. MHz	Reading Level dBuV/m	Correct Factor dB	Measure ment dBuV/m	Limit dBuV/m	Margin dB	Detector	Comment
1 *	11003.0800	36.85	13.92	50.77	74.00	-23.23	Peak	

REMARKS:

- (1) Measurement Value = Reading Level + Correct Factor.
- (2) Margin Level = Measurement Value - Limit Value.

Orthogonal Axis	X
Test Mode	UNII-2C_TX A Mode 5580 MHz

Vertical

130 dBuV/m

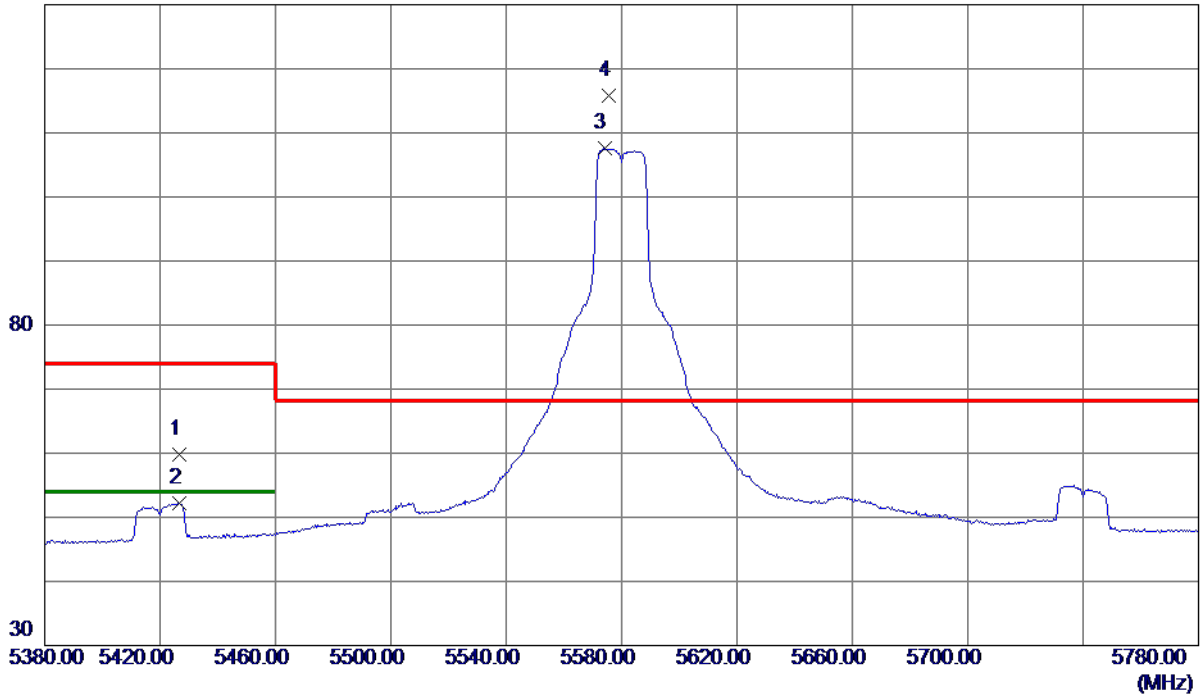

No.	Freq. MHz	Reading Level dBuV/m	Correct Factor dB	Measure ment dBuV/m	Limit dBuV/m	Margin dB	Detector	Comment
1	5426.8000	42.91	16.81	59.72	74.00	-14.28	Peak	
2	5426.8000	35.30	16.81	52.11	54.00	-1.89	AVG	
3	5574.0000	90.33	17.20	107.53	999.00	-891.47	AVG	No Limit
4 *	5575.6000	98.49	17.21	115.70	68.30	47.40	Peak	No Limit

REMARKS:

- (1) Measurement Value = Reading Level + Correct Factor.
- (2) Margin Level = Measurement Value - Limit Value.

Orthogonal Axis	X
Test Mode	UNII-2C_TX A Mode 5580 MHz

Vertical

80 dBuV/m

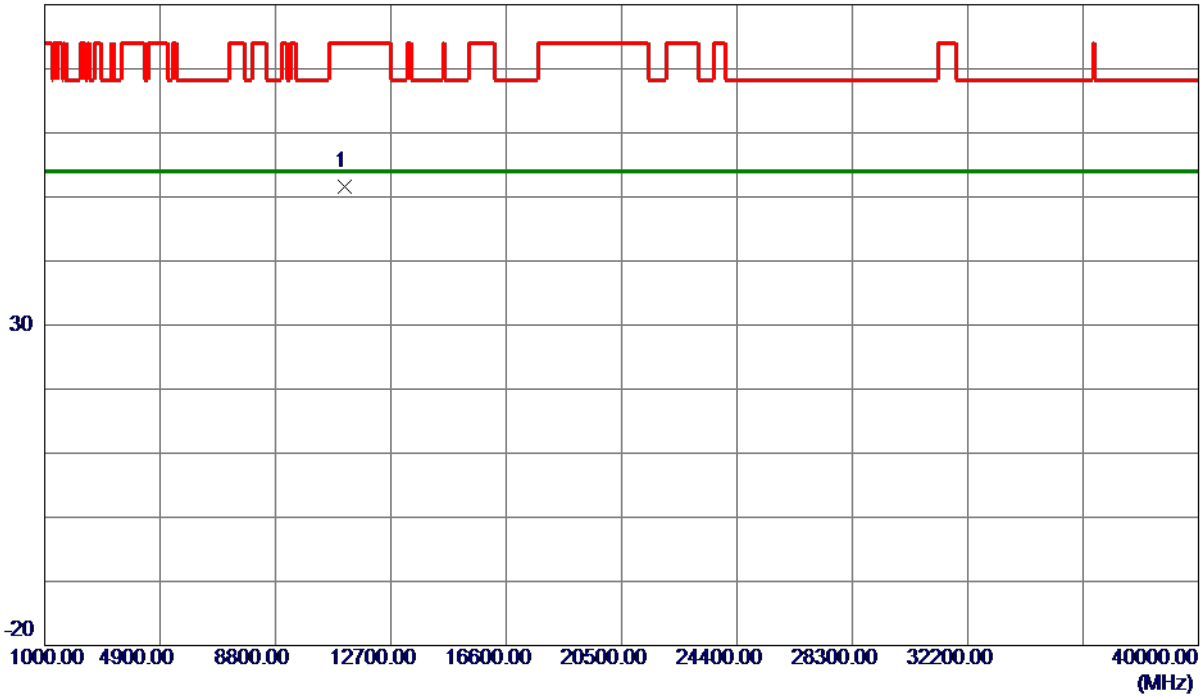

No.	Freq. MHz	Reading Level dBuV/m	Correct Factor dB	Measure ment dBuV/m	Limit dBuV/m	Margin dB	Detector	Comment
1 *	11161.3300	37.52	14.13	51.65	74.00	-22.35	Peak	

REMARKS:

- (1) Measurement Value = Reading Level + Correct Factor.
- (2) Margin Level = Measurement Value - Limit Value.

Orthogonal Axis	X
Test Mode	UNII-2C_TX A Mode 5580 MHz

Horizontal

130 dBuV/m

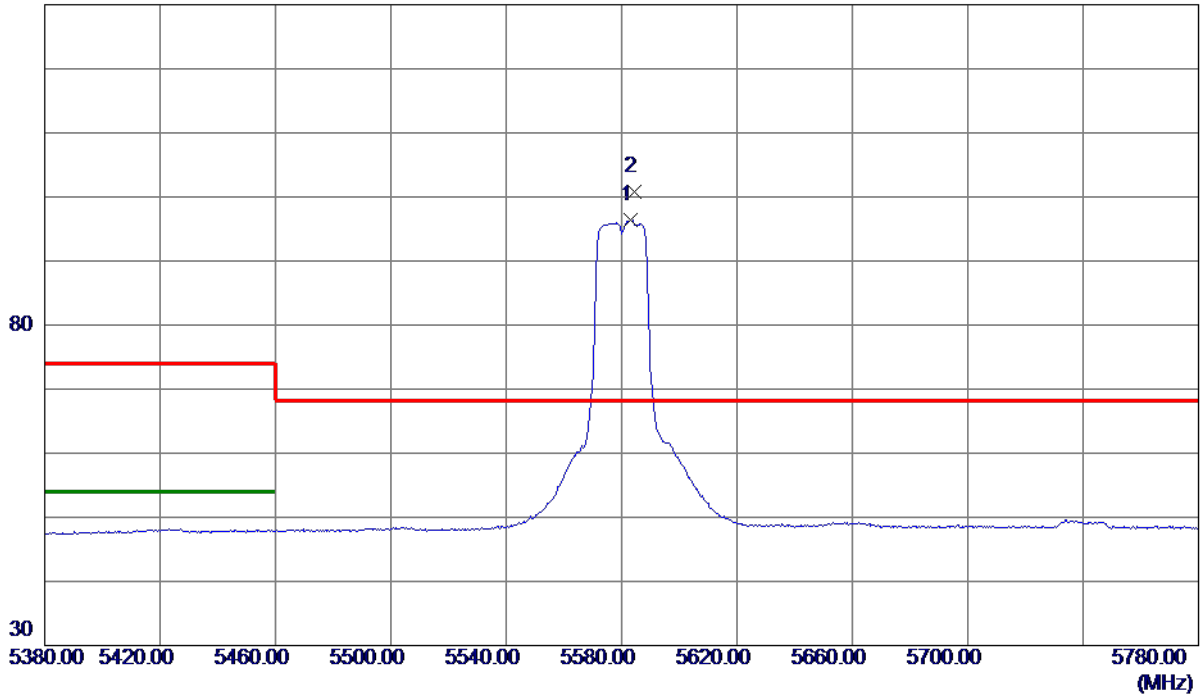

No.	Freq. MHz	Reading Level dBuV/m	Correct Factor dB	Measure ment dBuV/m	Limit dBuV/m	Margin dB	Detector	Comment
1	5583.2000	79.13	17.23	96.36	999.00	-902.64	AVG	No Limit
2 *	5584.4000	83.60	17.24	100.84	68.30	32.54	Peak	No Limit

REMARKS:

- (1) Measurement Value = Reading Level + Correct Factor.
- (2) Margin Level = Measurement Value - Limit Value.

Orthogonal Axis	X
Test Mode	UNII-2C_TX A Mode 5580 MHz

Horizontal

80 dBuV/m

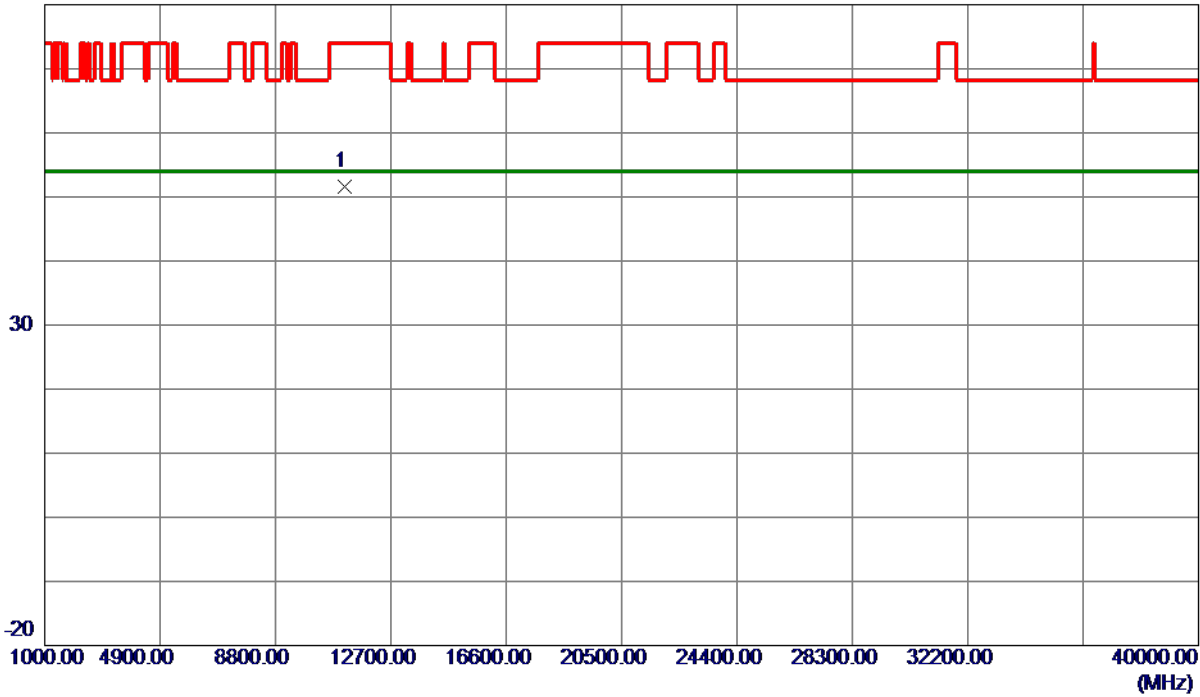

No.	Freq. MHz	Reading Level dBuV/m	Correct Factor dB	Measure ment dBuV/m	Limit dBuV/m	Margin dB	Detector	Comment
1 *	11161.4100	37.43	14.13	51.56	74.00	-22.44	Peak	

REMARKS:

- (1) Measurement Value = Reading Level + Correct Factor.
- (2) Margin Level = Measurement Value - Limit Value.

Orthogonal Axis	X
Test Mode	UNII-2C_TX A Mode 5700 MHz

Vertical

130 dBuV/m

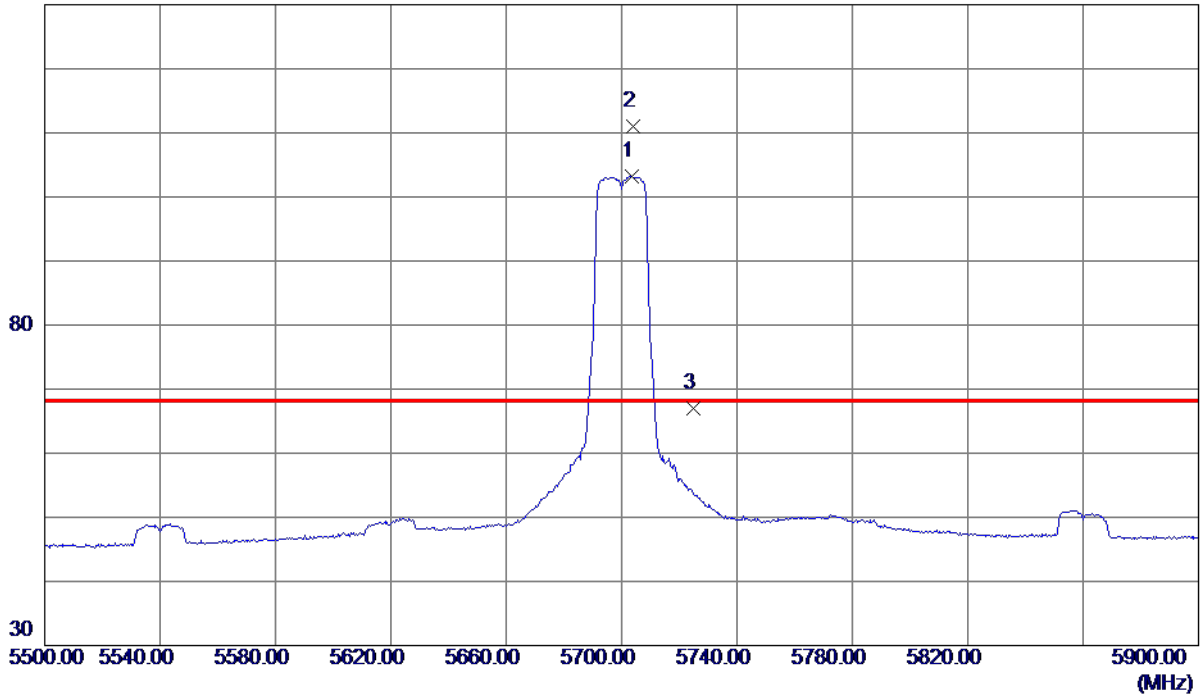

No.	Freq. MHz	Reading Level dBuV/m	Correct Factor dB	Measure ment dBuV/m	Limit dBuV/m	Margin dB	Detector	Comment
1	5703.6000	85.55	17.59	103.14	999.00	-895.86	AVG	No Limit
2 *	5704.0000	93.49	17.59	111.08	68.30	42.78	Peak	No Limit
3	5725.0000	49.40	17.65	67.05	68.30	-1.25	Peak	

REMARKS:

- (1) Measurement Value = Reading Level + Correct Factor.
- (2) Margin Level = Measurement Value - Limit Value.

Orthogonal Axis	X
Test Mode	UNII-2C_TX A Mode 5700 MHz

Vertical

80 dBuV/m

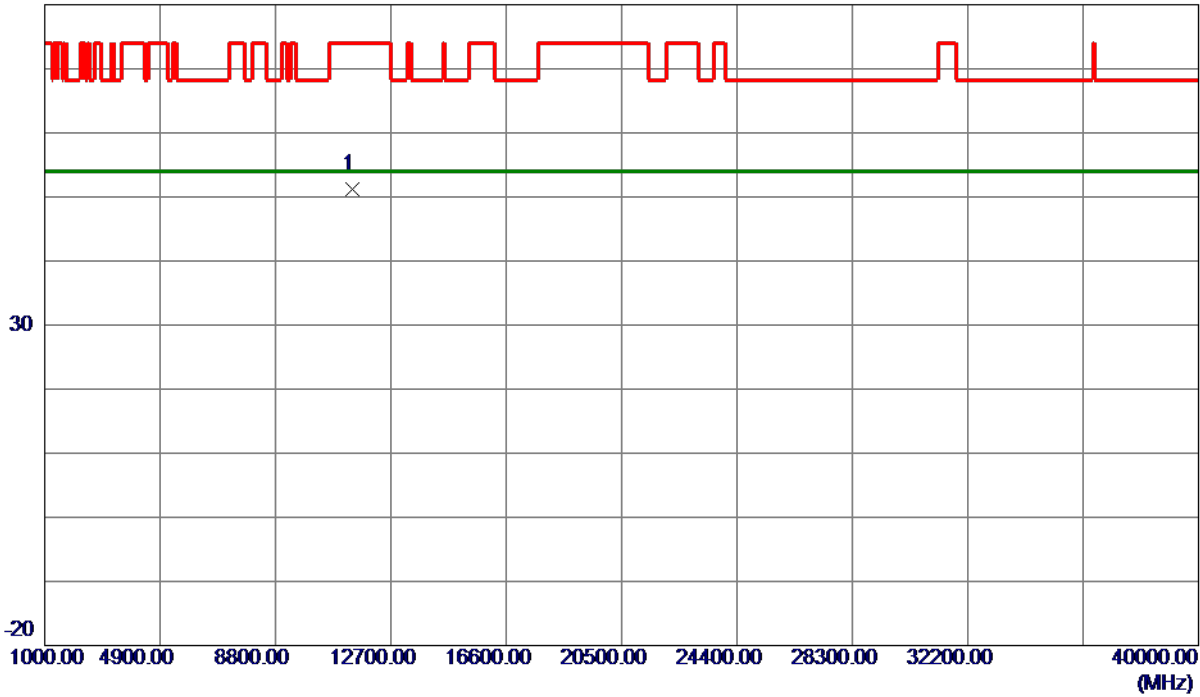

No.	Freq. MHz	Reading Level dBuV/m	Correct Factor dB	Measure ment dBuV/m	Limit dBuV/m	Margin dB	Detector	Comment
1 *	11403.9000	36.85	14.44	51.29	74.00	-22.71	Peak	

REMARKS:

- (1) Measurement Value = Reading Level + Correct Factor.
- (2) Margin Level = Measurement Value - Limit Value.

Orthogonal Axis	X
Test Mode	UNII-2C_TX A Mode 5700 MHz

Horizontal

130 dBuV/m

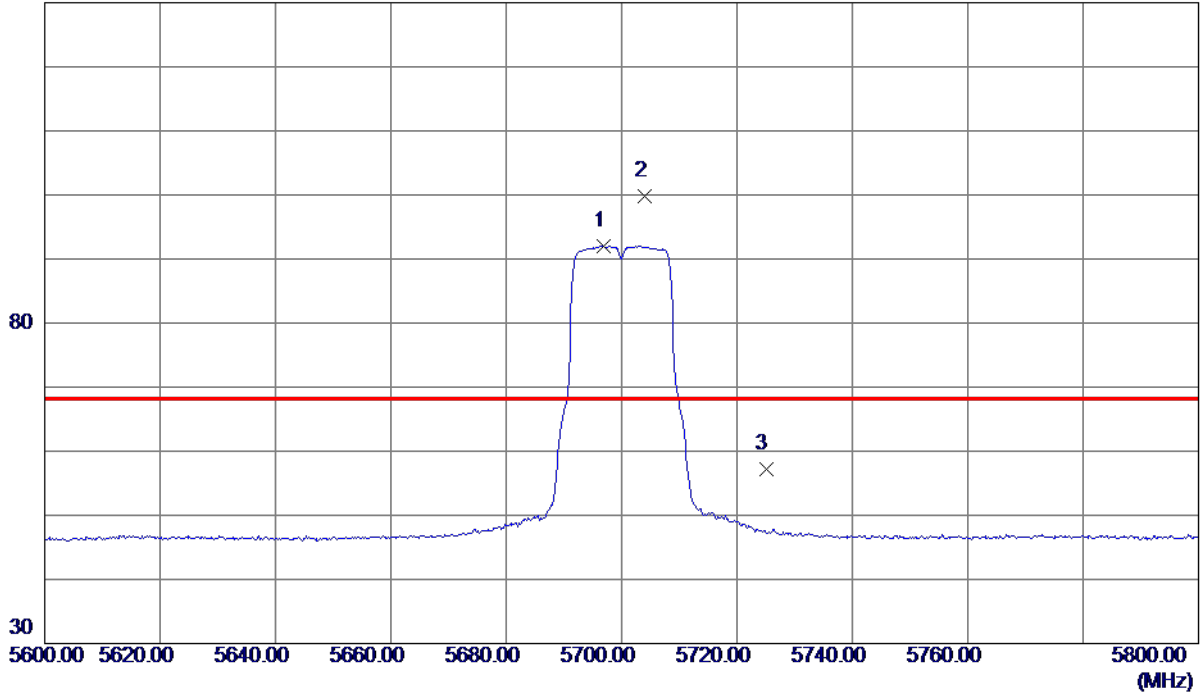

No.	Freq. MHz	Reading Level dBuV/m	Correct Factor dB	Measure ment dBuV/m	Limit dBuV/m	Margin dB	Detector	Comment
1	5696.8000	74.47	17.57	92.04	999.00	-906.96	AVG	No Limit
2 *	5704.0000	82.18	17.59	99.77	68.30	31.47	Peak	No Limit
3	5725.0000	39.64	17.65	57.29	68.30	-11.01	Peak	

REMARKS:

- (1) Measurement Value = Reading Level + Correct Factor.
- (2) Margin Level = Measurement Value - Limit Value.

Orthogonal Axis	X
Test Mode	UNII-2C_TX A Mode 5700 MHz

Horizontal

80 dBuV/m



No.	Freq. MHz	Reading Level dBuV/m	Correct Factor dB	Measure ment dBuV/m	Limit dBuV/m	Margin dB	Detector	Comment
1 *	11406.6100	37.65	14.44	52.09	74.00	-21.91	Peak	

REMARKS:

- (1) Measurement Value = Reading Level + Correct Factor.
- (2) Margin Level = Measurement Value - Limit Value.

Orthogonal Axis	X
Test Mode	UNII-3_TX A Mode 5745 MHz

Vertical

130 dBuV/m

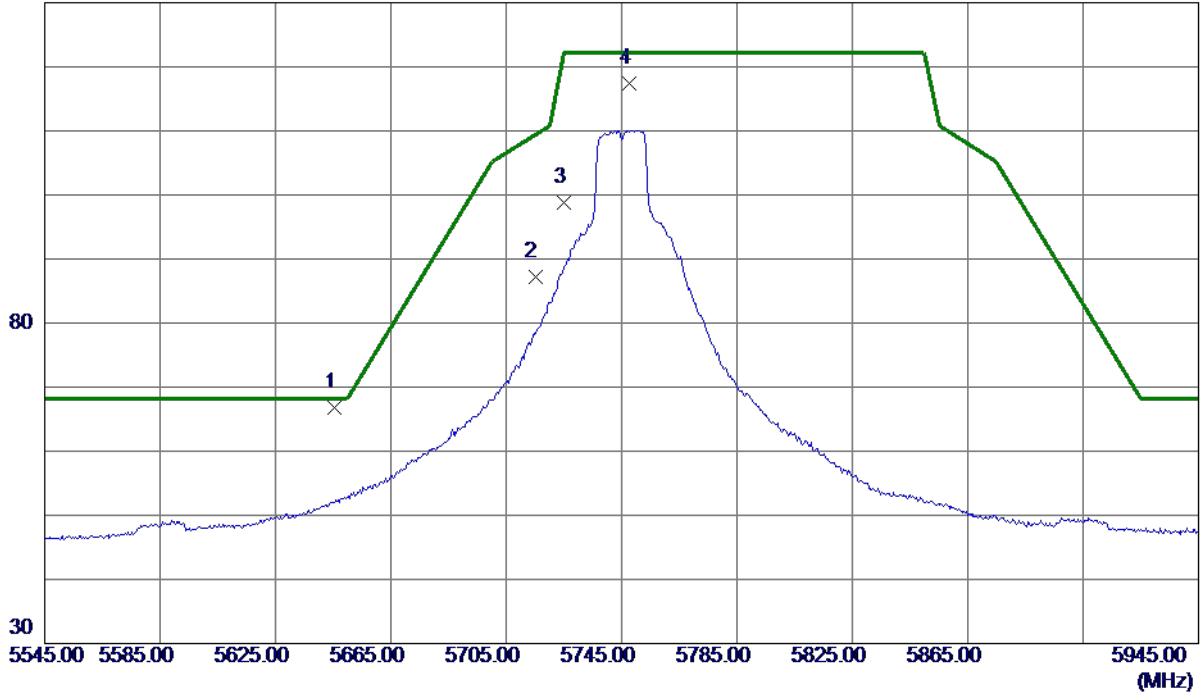

No.	Freq. MHz	Reading Level dBuV/m	Correct Factor dB	Measure ment dBuV/m	Limit dBuV/m	Margin dB	Detector	Comment
1 *	5645.2850	49.42	17.42	66.84	68.20	-1.36	Peak	
2	5715.0000	69.50	17.62	87.12	109.40	-22.28	Peak	
3	5725.0000	81.10	17.65	98.75	122.20	-23.45	Peak	
4	5747.8000	99.73	17.72	117.45	122.20	-4.75	Peak	No Limit

REMARKS:

- (1) Measurement Value = Reading Level + Correct Factor.
- (2) Margin Level = Measurement Value - Limit Value.

Orthogonal Axis	X
Test Mode	UNII-3_TX A Mode 5745 MHz

Vertical

80 dBuV/m

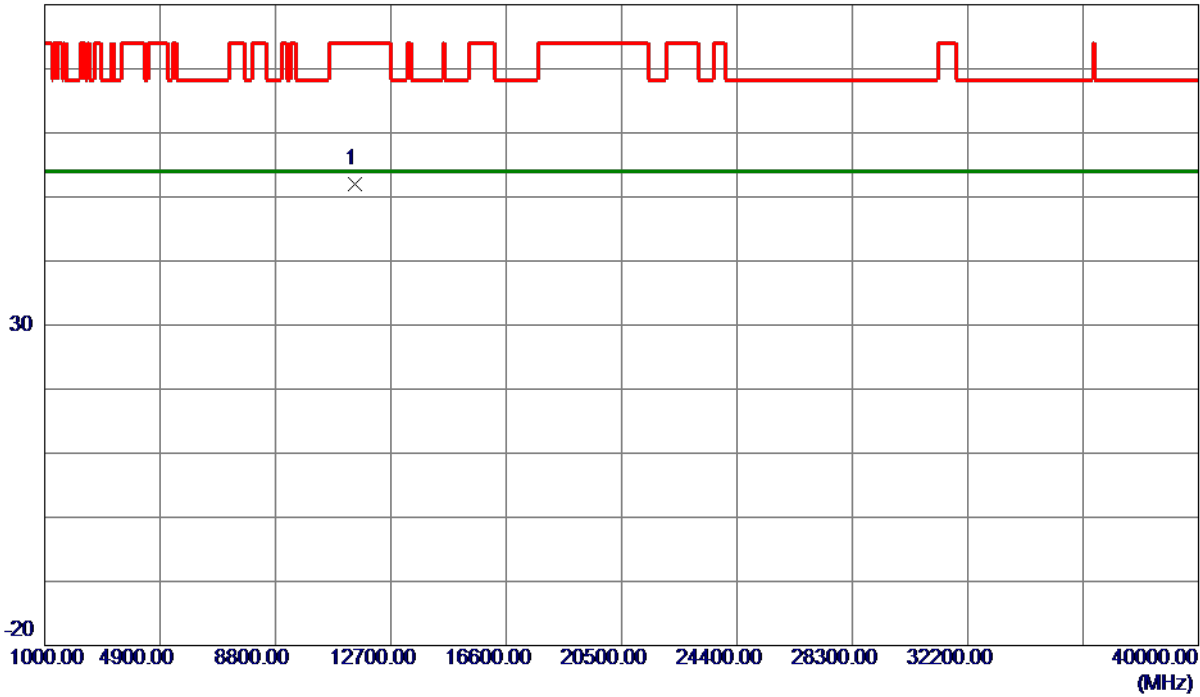

No.	Freq. MHz	Reading Level dBuV/m	Correct Factor dB	Measure ment dBuV/m	Limit dBuV/m	Margin dB	Detector	Comment
1 *	11485.8200	37.50	14.55	52.05	74.00	-21.95	Peak	

REMARKS:

- (1) Measurement Value = Reading Level + Correct Factor.
- (2) Margin Level = Measurement Value - Limit Value.

Orthogonal Axis	X
Test Mode	UNII-3_TX A Mode 5745 MHz

Horizontal

130 dBuV/m

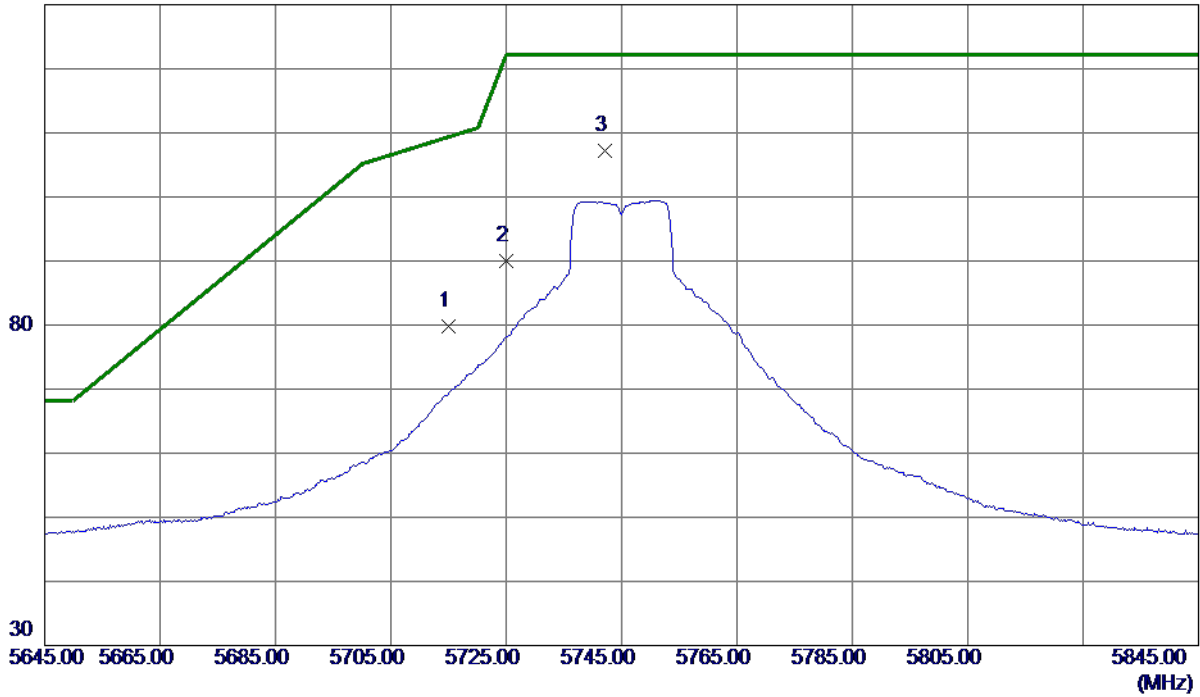

No.	Freq. MHz	Reading Level dBuV/m	Correct Factor dB	Measure ment dBuV/m	Limit dBuV/m	Margin dB	Detector	Comment
1	5715.0000	62.20	17.62	79.82	109.40	-29.58	Peak	
2	5725.0000	72.40	17.65	90.05	122.20	-32.15	Peak	
3 *	5742.2000	89.57	17.70	107.27	122.20	-14.93	Peak	No Limit

REMARKS:

- (1) Measurement Value = Reading Level + Correct Factor.
- (2) Margin Level = Measurement Value - Limit Value.

Orthogonal Axis	X
Test Mode	UNII-3_TX A Mode 5745 MHz

Horizontal

80 dBuV/m

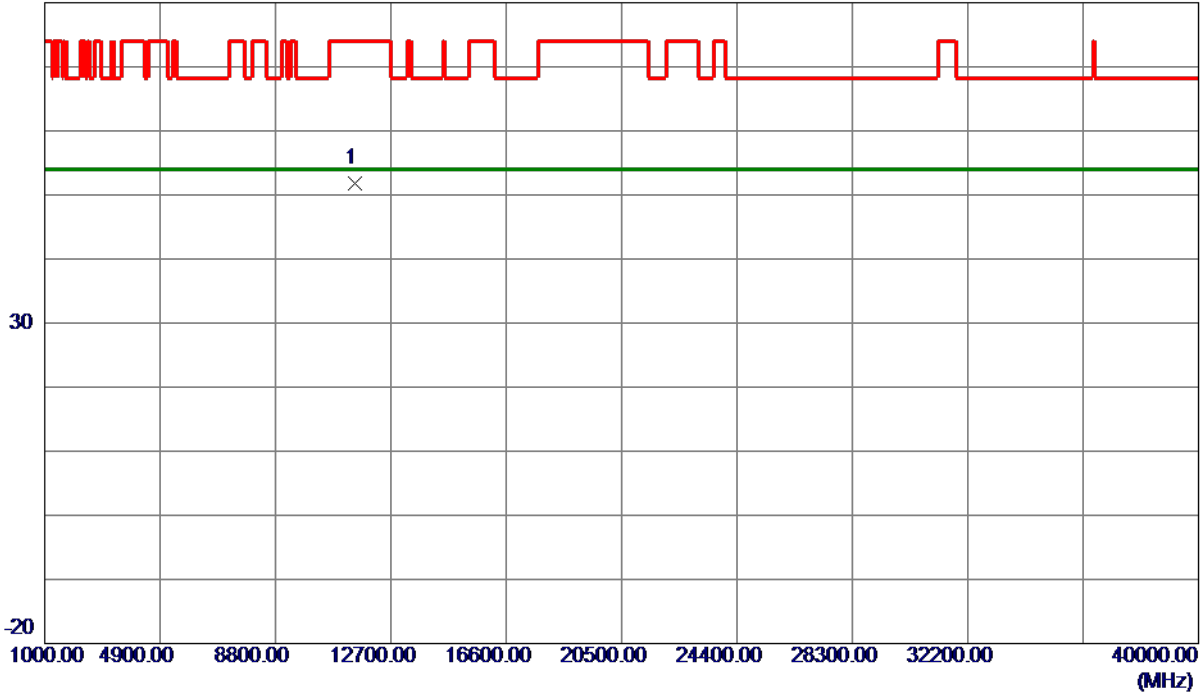

No.	Freq. MHz	Reading Level dBuV/m	Correct Factor dB	Measure ment dBuV/m	Limit dBuV/m	Margin dB	Detector	Comment
1 *	11485.7400	37.22	14.55	51.77	74.00	-22.23	Peak	

REMARKS:

- (1) Measurement Value = Reading Level + Correct Factor.
- (2) Margin Level = Measurement Value - Limit Value.

Orthogonal Axis	X
Test Mode	UNII-3_TX A Mode 5785 MHz

Vertical

130 dBuV/m

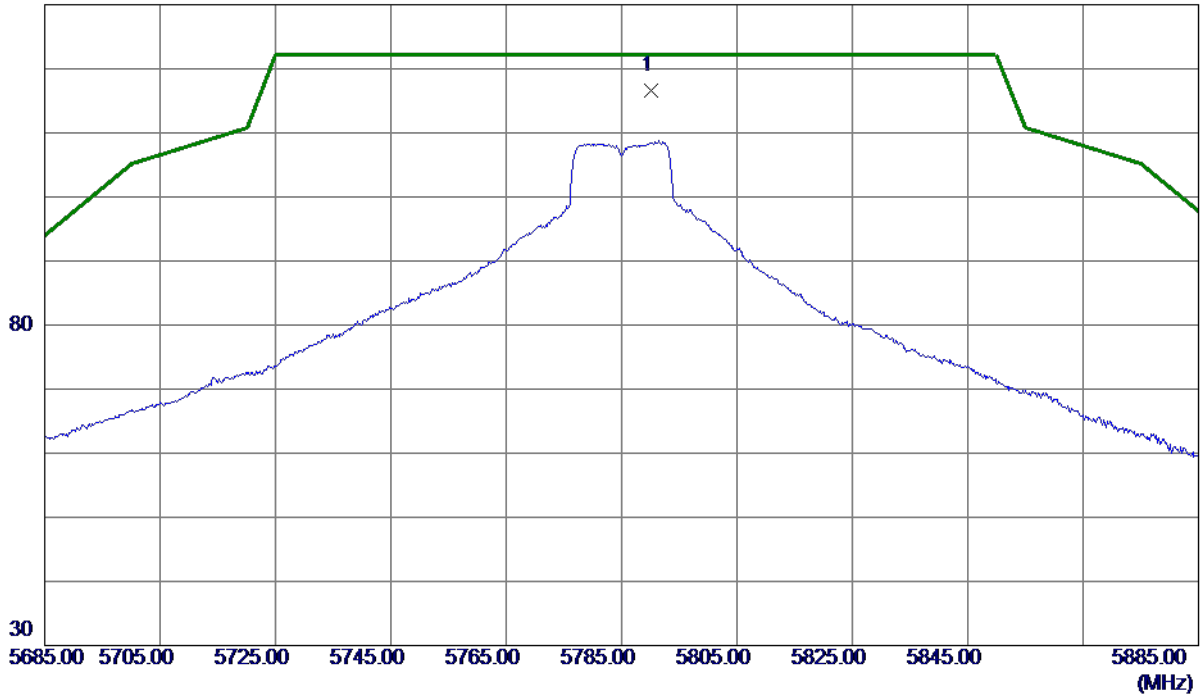

No.	Freq. MHz	Reading Level dBuV/m	Correct Factor dB	Measure ment dBuV/m	Limit dBuV/m	Margin dB	Detector	Comment
1 *	5790.2000	98.72	17.85	116.57	122.20	-5.63	Peak	No Limit

REMARKS:

- (1) Measurement Value = Reading Level + Correct Factor.
- (2) Margin Level = Measurement Value - Limit Value.

Orthogonal Axis	X
Test Mode	UNII-3_TX A Mode 5785 MHz

Vertical

80 dBuV/m

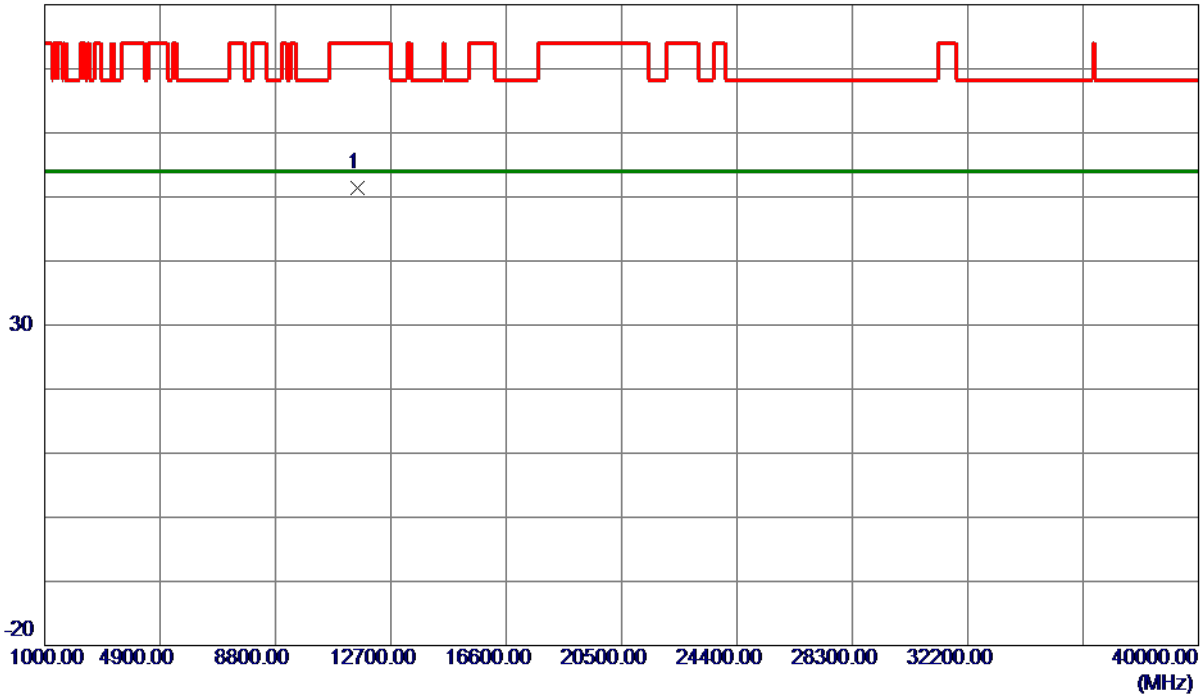

No.	Freq. MHz	Reading Level dBuV/m	Correct Factor dB	Measure ment dBuV/m	Limit dBuV/m	Margin dB	Detector	Comment
1 *	11569.0700	36.78	14.57	51.35	74.00	-22.65	Peak	

REMARKS:

- (1) Measurement Value = Reading Level + Correct Factor.
- (2) Margin Level = Measurement Value - Limit Value.

Orthogonal Axis	X
Test Mode	UNII-3_TX A Mode 5785 MHz

Horizontal

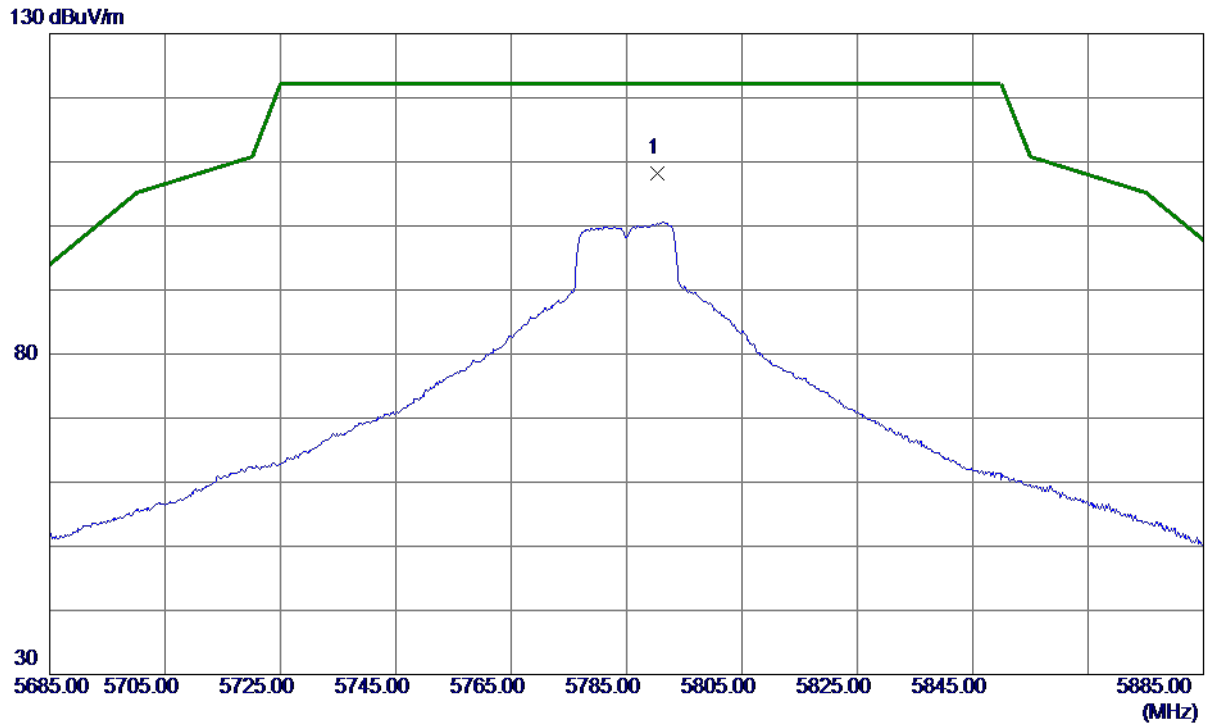

No.	Freq. MHz	Reading Level dBuV/m	Correct Factor dB	Measure ment dBuV/m	Limit dBuV/m	Margin dB	Detector	Comment
1 *	5790.4000	90.35	17.85	108.20	122.20	-14.00	Peak	No Limit

REMARKS:

- (1) Measurement Value = Reading Level + Correct Factor.
- (2) Margin Level = Measurement Value - Limit Value.

Orthogonal Axis	X
Test Mode	UNII-3_TX A Mode 5785 MHz

Horizontal

80 dBuV/m



No.	Freq. MHz	Reading Level dBuV/m	Correct Factor dB	Measure ment dBuV/m	Limit dBuV/m	Margin dB	Detector	Comment
1 *	11574.4700	36.91	14.57	51.48	74.00	-22.52	Peak	

REMARKS:

- (1) Measurement Value = Reading Level + Correct Factor.
- (2) Margin Level = Measurement Value - Limit Value.

Orthogonal Axis	X
Test Mode	UNII-3_TX A Mode 5825 MHz

Vertical

130 dBuV/m

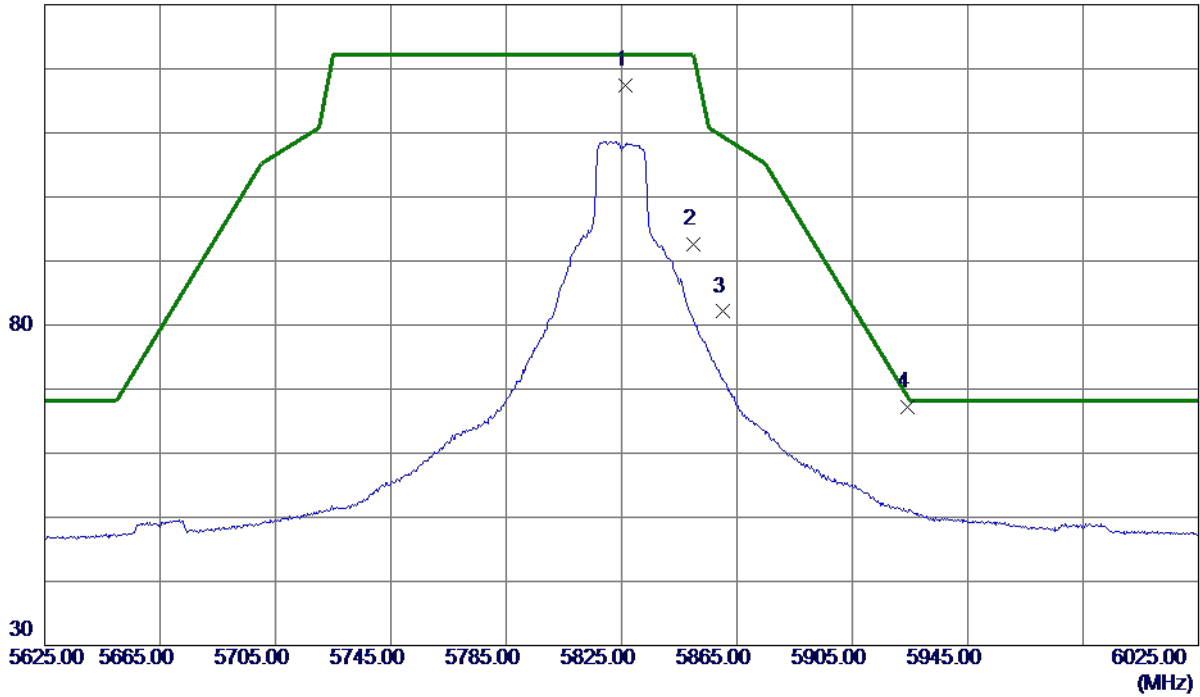

No.	Freq. MHz	Reading Level dBuV/m	Correct Factor dB	Measure ment dBuV/m	Limit dBuV/m	Margin dB	Detector	Comment
1	5826.2000	99.38	17.95	117.33	122.20	-4.87	Peak	No Limit
2	5850.0000	74.54	18.02	92.56	122.20	-29.64	Peak	
3	5860.0000	64.05	18.05	82.10	109.40	-27.30	Peak	
4 *	5924.0000	48.95	18.24	67.19	68.94	-1.75	Peak	

REMARKS:

- (1) Measurement Value = Reading Level + Correct Factor.
- (2) Margin Level = Measurement Value - Limit Value.

Orthogonal Axis	X
Test Mode	UNII-3_TX A Mode 5825 MHz

Vertical

80 dBuV/m

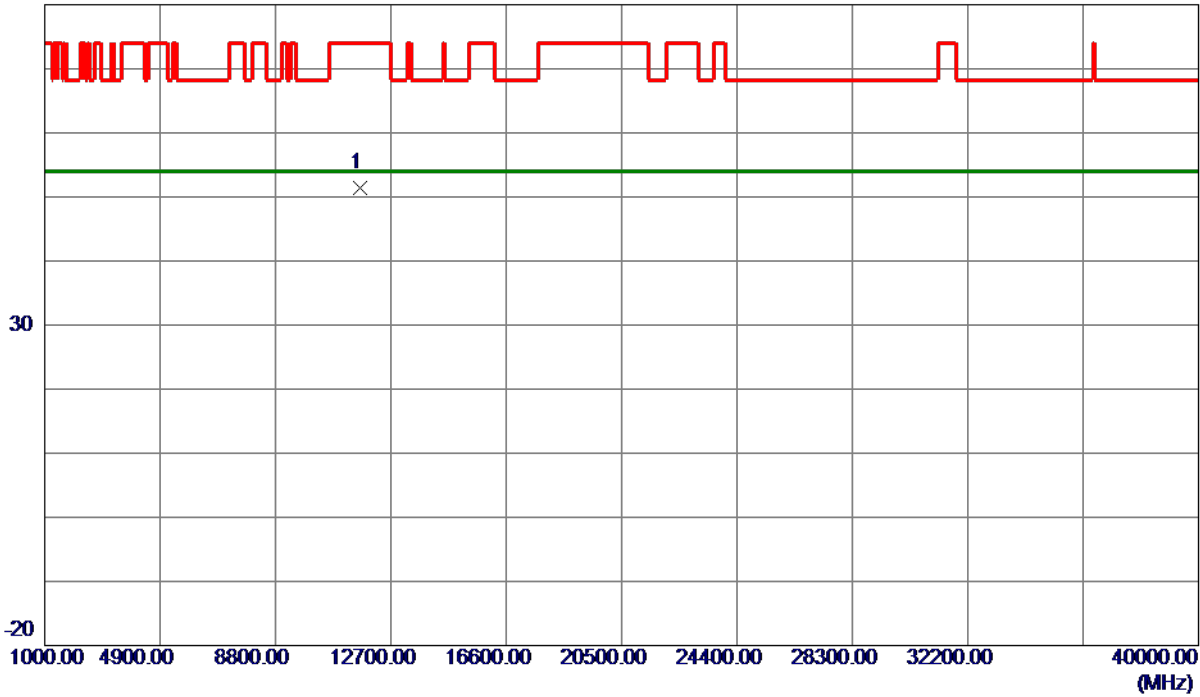

No.	Freq. MHz	Reading Level dBuV/m	Correct Factor dB	Measure ment dBuV/m	Limit dBuV/m	Margin dB	Detector	Comment
1 *	11652.5700	36.78	14.57	51.35	74.00	-22.65	Peak	

REMARKS:

- (1) Measurement Value = Reading Level + Correct Factor.
- (2) Margin Level = Measurement Value - Limit Value.

Orthogonal Axis	X
Test Mode	UNII-3_TX A Mode 5825 MHz

Horizontal

130 dBuV/m

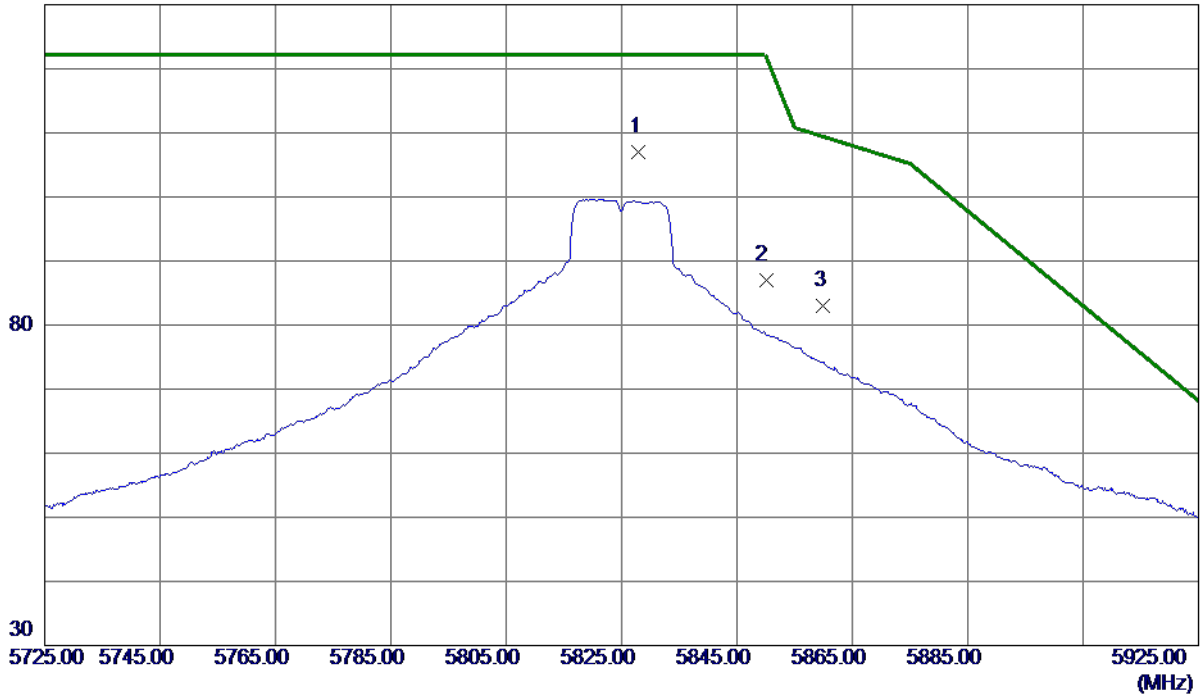

No.	Freq. MHz	Reading Level dBuV/m	Correct Factor dB	Measure ment dBuV/m	Limit dBuV/m	Margin dB	Detector	Comment
1 *	5828.0000	89.11	17.96	107.07	122.20	-15.13	Peak	No Limit
2	5850.0000	68.90	18.02	86.92	122.20	-35.28	Peak	
3	5860.0000	64.91	18.05	82.96	109.40	-26.44	Peak	

REMARKS:

- (1) Measurement Value = Reading Level + Correct Factor.
- (2) Margin Level = Measurement Value - Limit Value.

Orthogonal Axis	X
Test Mode	UNII-3_TX A Mode 5825 MHz

Horizontal

80 dBuV/m

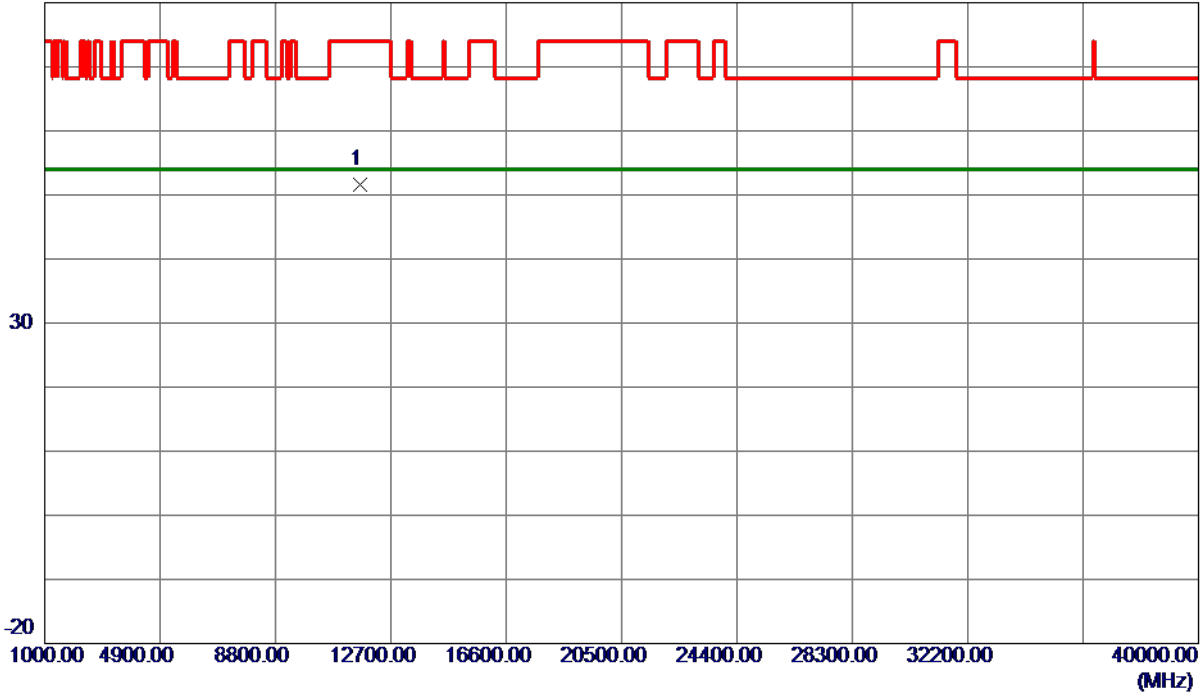

No.	Freq. MHz	Reading Level dBuV/m	Correct Factor dB	Measure ment dBuV/m	Limit dBuV/m	Margin dB	Detector	Comment
1 *	11650.0000	37.08	14.57	51.65	74.00	-22.35	Peak	

REMARKS:

- (1) Measurement Value = Reading Level + Correct Factor.
- (2) Margin Level = Measurement Value - Limit Value.

Orthogonal Axis	X
Test Mode	UNII-1_TX AC (VHT20) Mode 5180 MHz

Vertical

130 dBuV/m

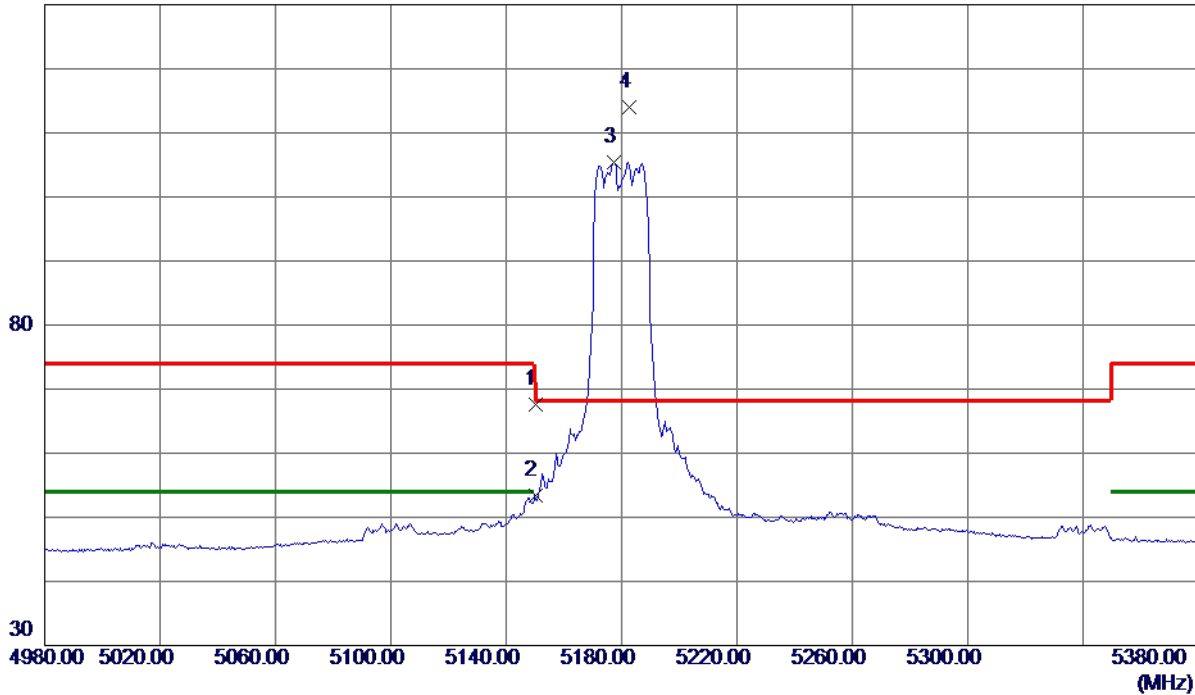

No.	Freq. MHz	Reading Level dBuV/m	Correct Factor dB	Measure ment dBuV/m	Limit dBuV/m	Margin dB	Detector	Comment
1	5150.0000	51.37	16.16	67.53	74.00	-6.47	Peak	
2	5150.0000	37.19	16.16	53.35	54.00	-0.65	AVG	
3	5177.2000	89.16	16.22	105.38	999.00	-893.62	AVG	No Limit
4 *	5182.8000	97.74	16.23	113.97	68.30	45.67	Peak	No Limit

REMARKS:

- (1) Measurement Value = Reading Level + Correct Factor.
- (2) Margin Level = Measurement Value - Limit Value.

Orthogonal Axis	X
Test Mode	UNII-1_TX AC (VHT20) Mode 5180 MHz

Vertical

80 dBuV/m

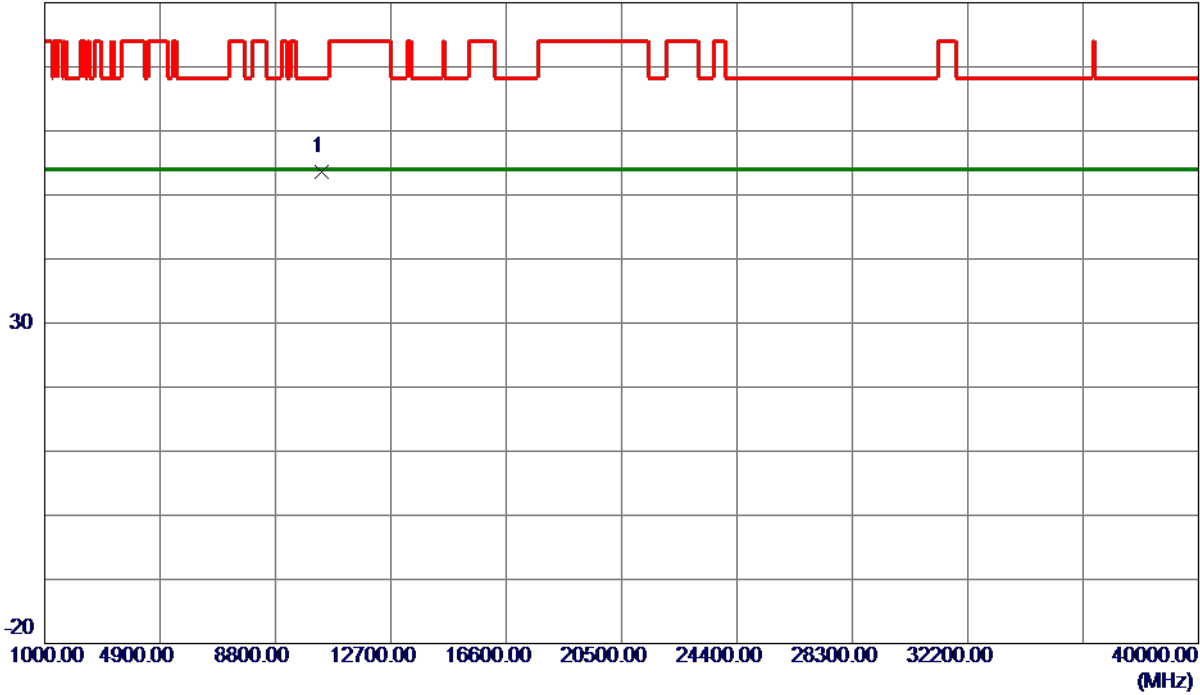

No.	Freq. MHz	Reading Level dBuV/m	Correct Factor dB	Measure ment dBuV/m	Limit dBuV/m	Margin dB	Detector	Comment
1 *	10358.0250	40.04	13.51	53.55	68.30	-14.75	Peak	

REMARKS:

- (1) Measurement Value = Reading Level + Correct Factor.
- (2) Margin Level = Measurement Value - Limit Value.

Orthogonal Axis	X
Test Mode	UNII-1_TX AC (VHT20) Mode 5180 MHz

Horizontal

130 dBuV/m

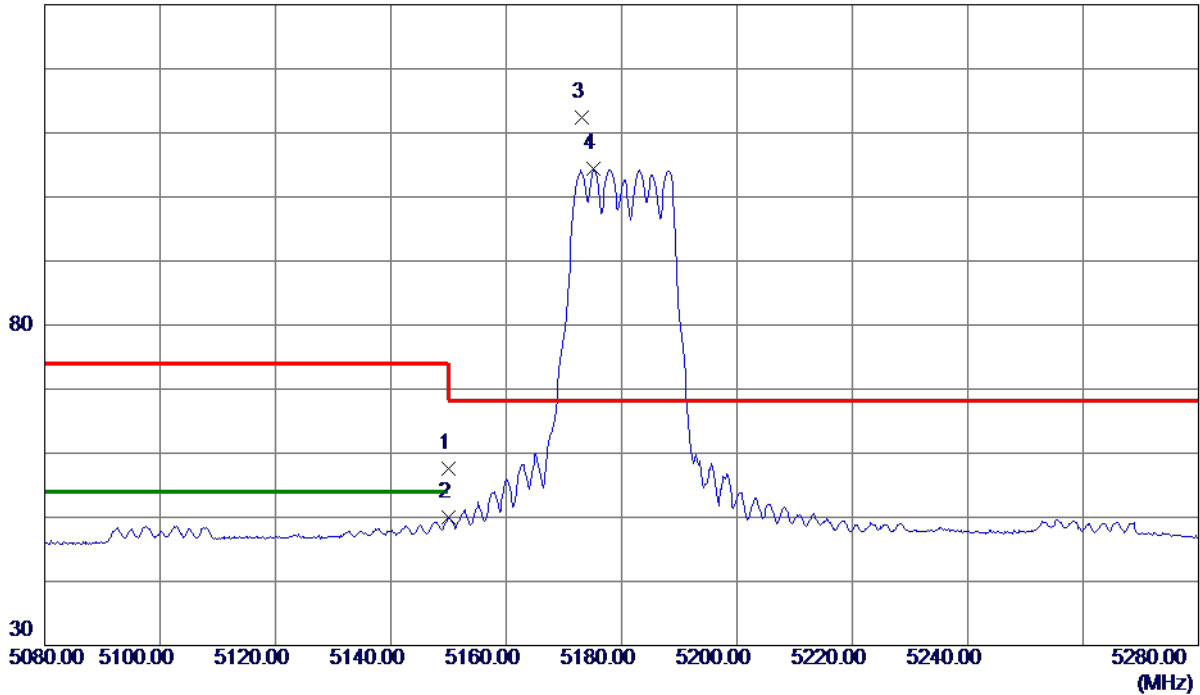

No.	Freq. MHz	Reading Level dBuV/m	Correct Factor dB	Measure ment dBuV/m	Limit dBuV/m	Margin dB	Detector	Comment
1	5150.0000	41.48	16.16	57.64	74.00	-16.36	Peak	
2	5150.0000	33.79	16.16	49.95	54.00	-4.05	AVG	
3 *	5173.2000	96.14	16.21	112.35	68.30	44.05	Peak	No Limit
4	5175.2000	88.10	16.22	104.32	999.00	-894.68	AVG	No Limit

REMARKS:

- (1) Measurement Value = Reading Level + Correct Factor.
- (2) Margin Level = Measurement Value - Limit Value.

Orthogonal Axis	X
Test Mode	UNII-1_TX AC (VHT20) Mode 5180 MHz

Horizontal

80 dBuV/m

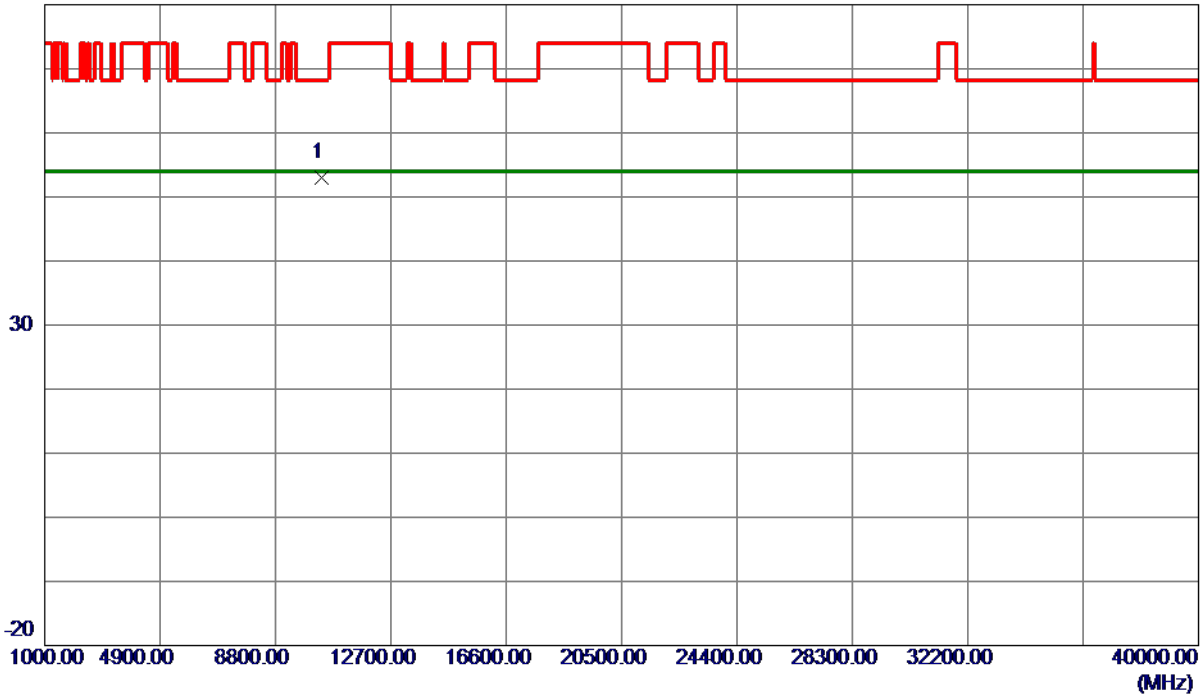

No.	Freq. MHz	Reading Level dBuV/m	Correct Factor dB	Measure ment dBuV/m	Limit dBuV/m	Margin dB	Detector	Comment
1 *	10359.3850	39.41	13.51	52.92	68.30	-15.38	Peak	

REMARKS:

- (1) Measurement Value = Reading Level + Correct Factor.
- (2) Margin Level = Measurement Value - Limit Value.

Orthogonal Axis	X
Test Mode	UNII-1_TX AC (VHT20) Mode 5200 MHz

Vertical

130 dBuV/m

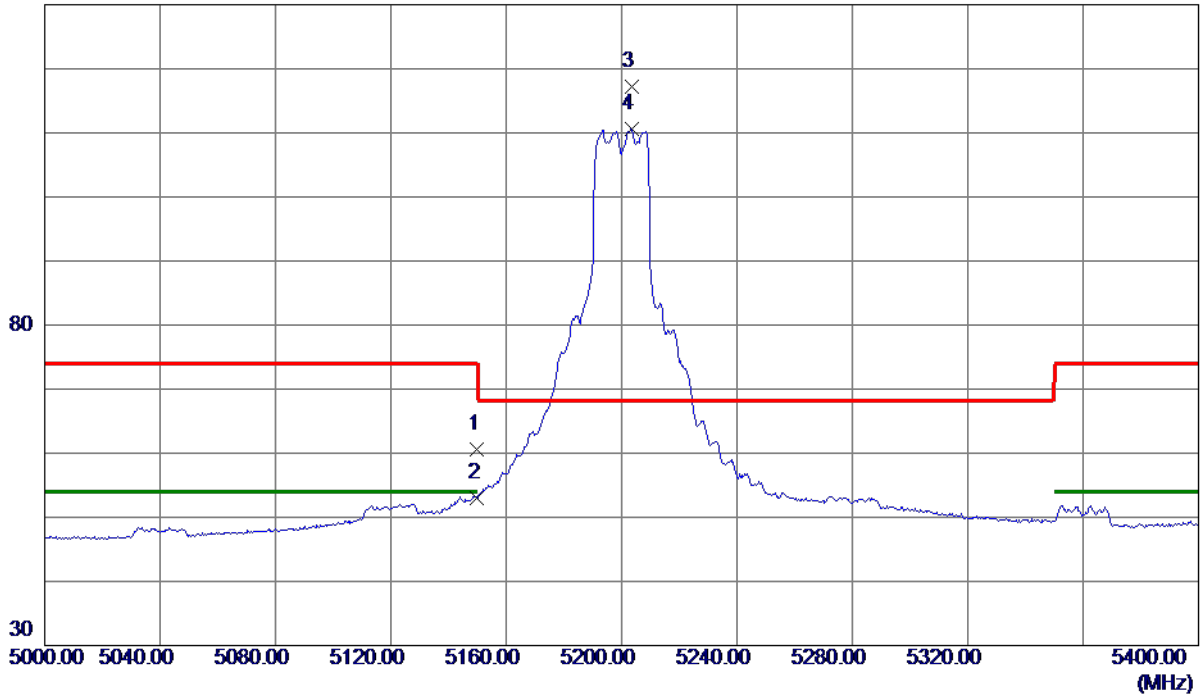

No.	Freq. MHz	Reading Level dBuV/m	Correct Factor dB	Measure ment dBuV/m	Limit dBuV/m	Margin dB	Detector	Comment
1	5150.0000	44.36	16.16	60.52	74.00	-13.48	Peak	
2	5150.0000	36.91	16.16	53.07	54.00	-0.93	AVG	
3 *	5203.6000	100.88	16.28	117.16	68.30	48.86	Peak	No Limit
4	5203.6000	94.28	16.28	110.56	999.00	-888.44	AVG	No Limit

REMARKS:

- (1) Measurement Value = Reading Level + Correct Factor.
- (2) Margin Level = Measurement Value - Limit Value.

Orthogonal Axis	X
Test Mode	UNII-1_TX AC (VHT20) Mode 5200 MHz

Vertical

80 dBuV/m

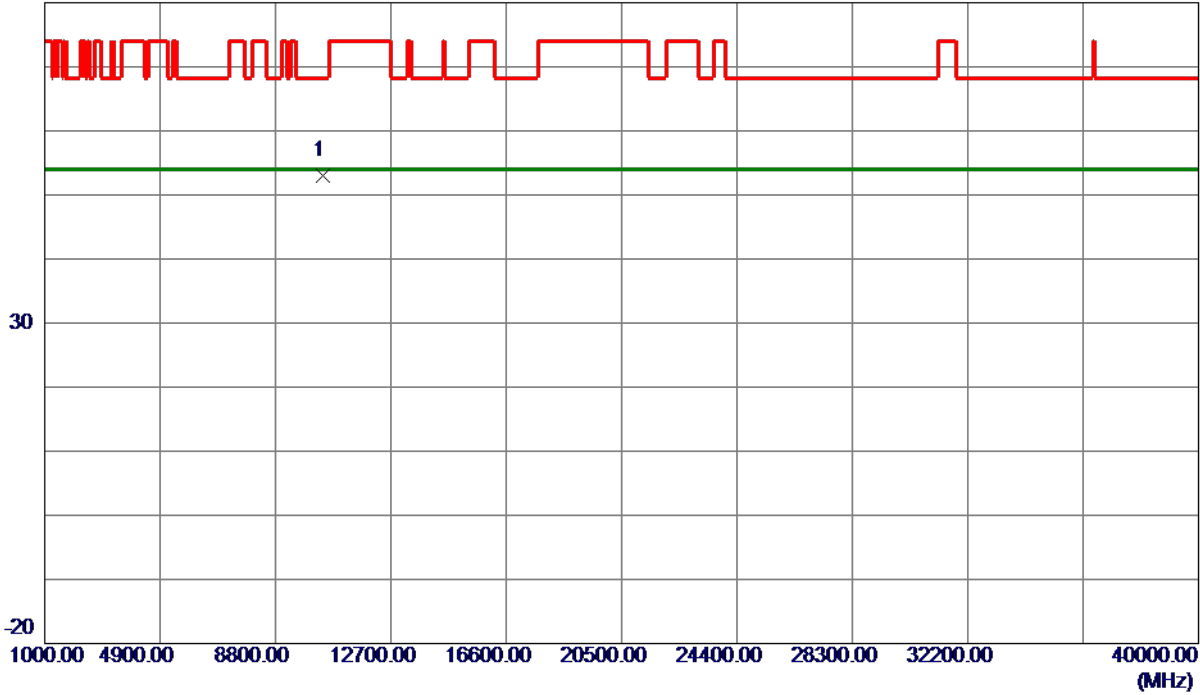

No.	Freq. MHz	Reading Level dBuV/m	Correct Factor dB	Measure ment dBuV/m	Limit dBuV/m	Margin dB	Detector	Comment
1 *	10400.3150	39.47	13.55	53.02	68.30	-15.28	Peak	

REMARKS:

- (1) Measurement Value = Reading Level + Correct Factor.
- (2) Margin Level = Measurement Value - Limit Value.

Orthogonal Axis	X
Test Mode	UNII-1_TX AC (VHT20) Mode 5200 MHz

Horizontal

130 dBuV/m

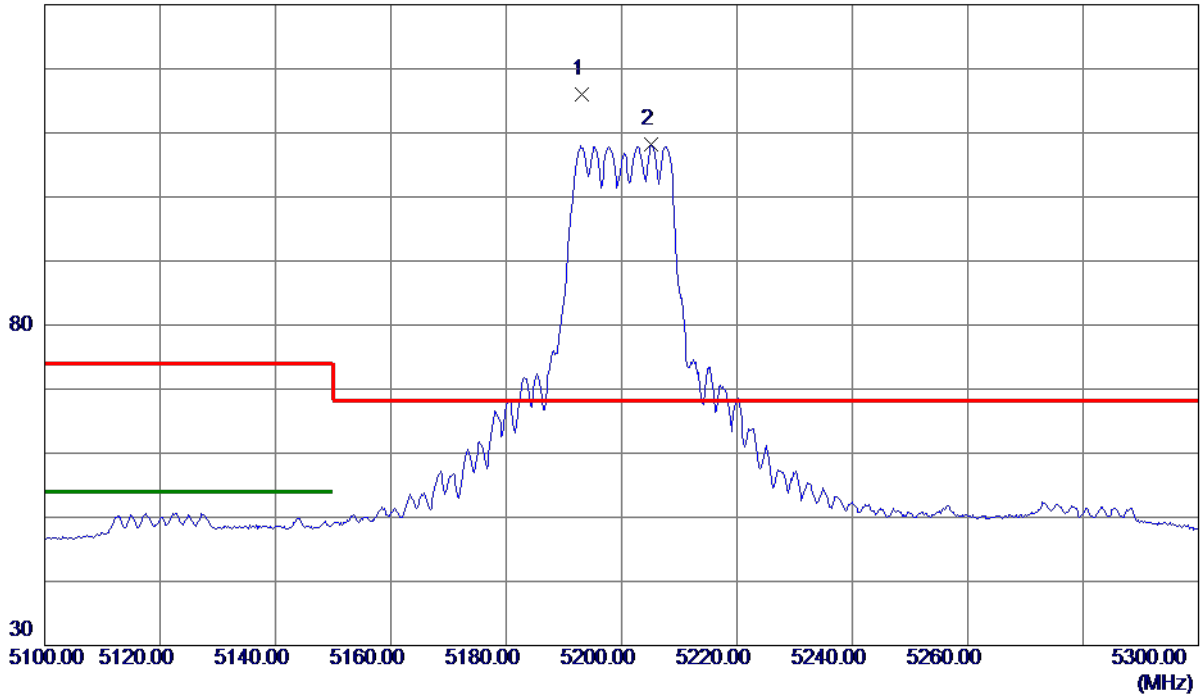

No.	Freq. MHz	Reading Level dBuV/m	Correct Factor dB	Measure ment dBuV/m	Limit dBuV/m	Margin dB	Detector	Comment
1 *	5193.2000	99.72	16.26	115.98	68.30	47.68	Peak	No Limit
2	5205.2000	91.98	16.29	108.27	999.00	-890.73	AVG	No Limit

REMARKS:

- (1) Measurement Value = Reading Level + Correct Factor.
- (2) Margin Level = Measurement Value - Limit Value.

Orthogonal Axis	X
Test Mode	UNII-1_TX AC (VHT20) Mode 5200 MHz

Horizontal

80 dBuV/m

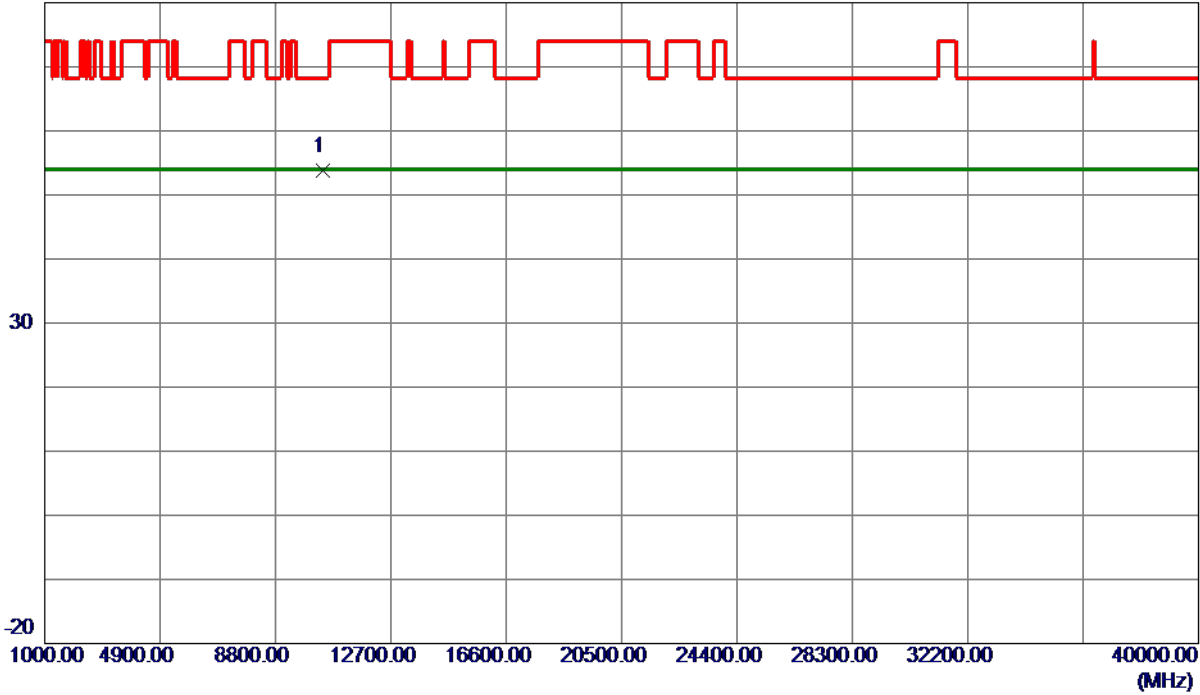

No.	Freq. MHz	Reading Level dBuV/m	Correct Factor dB	Measure ment dBuV/m	Limit dBuV/m	Margin dB	Detector	Comment
1 *	10397.7250	40.15	13.55	53.70	68.30	-14.60	Peak	

REMARKS:

- (1) Measurement Value = Reading Level + Correct Factor.
- (2) Margin Level = Measurement Value - Limit Value.

Orthogonal Axis	X
Test Mode	UNII-1_TX AC (VHT20) Mode 5240 MHz

Vertical

130 dBuV/m

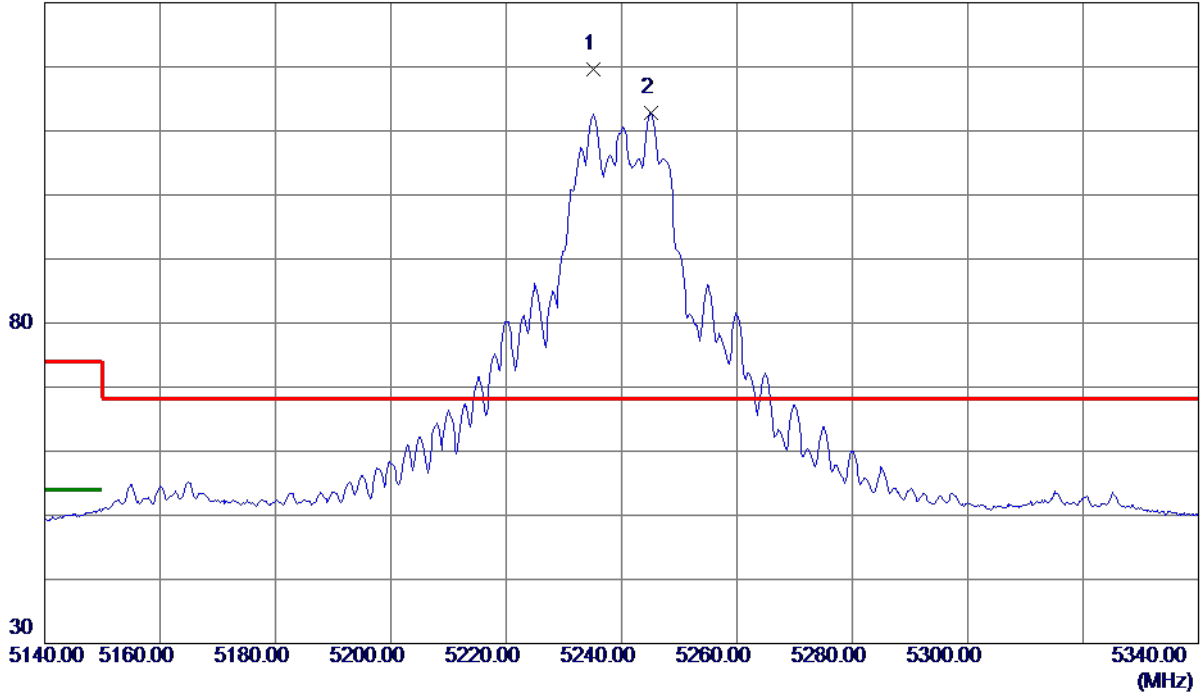

No.	Freq. MHz	Reading Level dBuV/m	Correct Factor dB	Measure ment dBuV/m	Limit dBuV/m	Margin dB	Detector	Comment
1 *	5235.2000	103.16	16.36	119.52	68.30	51.22	Peak	No Limit
2	5245.2000	96.49	16.38	112.87	999.00	-886.13	AVG	No Limit

REMARKS:

- (1) Measurement Value = Reading Level + Correct Factor.
- (2) Margin Level = Measurement Value - Limit Value.

Orthogonal Axis	X
Test Mode	UNII-1_TX AC (VHT20) Mode 5240 MHz

Vertical

80 dBuV/m

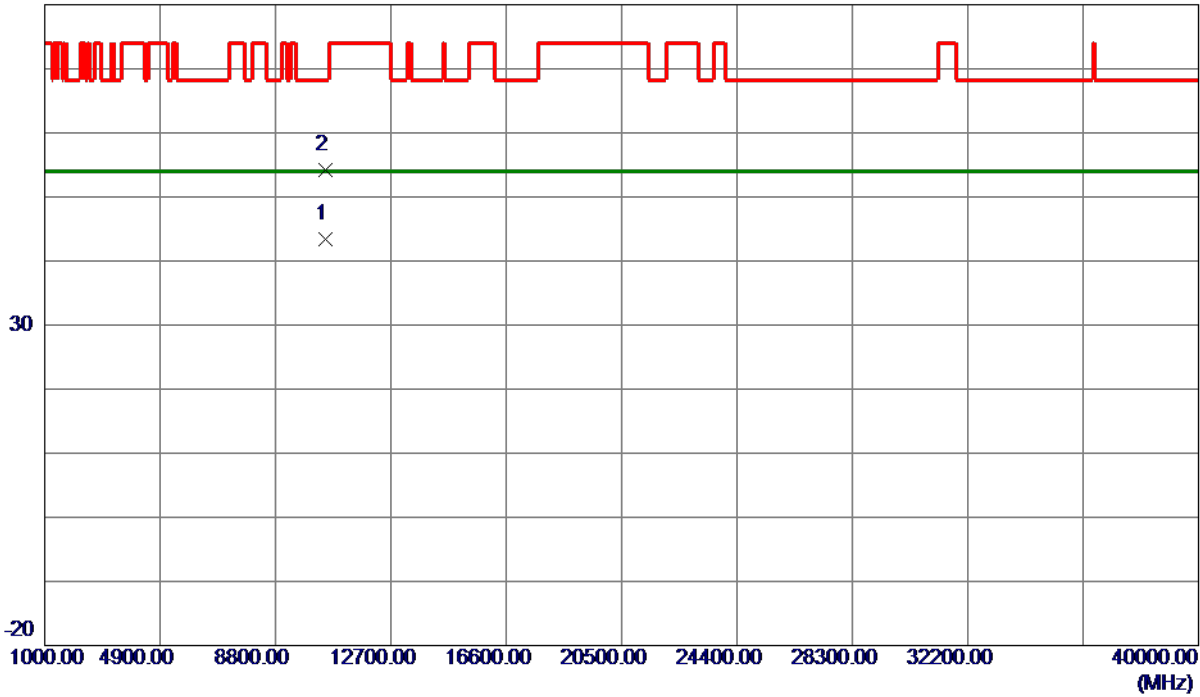

No.	Freq. MHz	Reading Level dBuV/m	Correct Factor dB	Measure ment dBuV/m	Limit dBuV/m	Margin dB	Detector	Comment
1 *	10480.1520	29.85	13.63	43.48	54.00	-10.52	AVG	
2	10480.7750	40.65	13.63	54.28	68.30	-14.02	Peak	

REMARKS:

- (1) Measurement Value = Reading Level + Correct Factor.
- (2) Margin Level = Measurement Value - Limit Value.

Orthogonal Axis	X
Test Mode	UNII-1_TX AC (VHT20) Mode 5240 MHz

Horizontal

130 dBuV/m

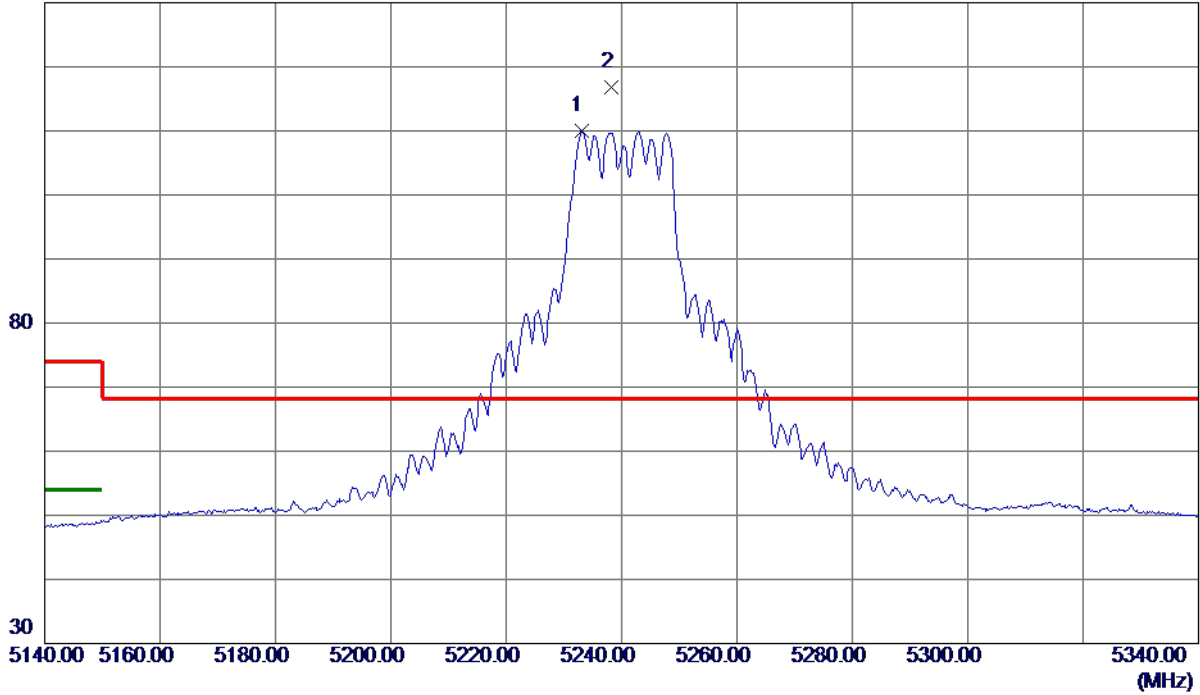

No.	Freq. MHz	Reading Level dBuV/m	Correct Factor dB	Measure ment dBuV/m	Limit dBuV/m	Margin dB	Detector	Comment
1	5233.0000	93.58	16.35	109.93	999.00	-889.07	AVG	No Limit
2 *	5238.2000	100.44	16.36	116.80	68.30	48.50	Peak	No Limit

REMARKS:

- (1) Measurement Value = Reading Level + Correct Factor.
- (2) Margin Level = Measurement Value - Limit Value.

Orthogonal Axis	X
Test Mode	UNII-1_TX AC (VHT20) Mode 5240 MHz

Horizontal

80 dBuV/m

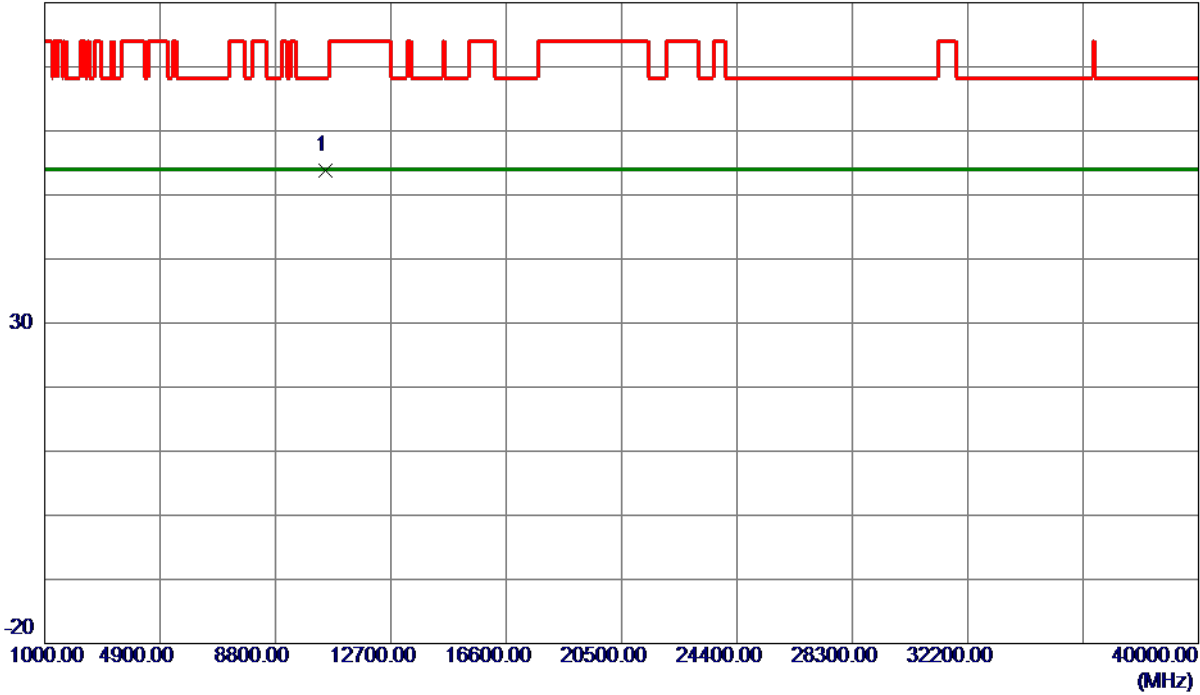

No.	Freq. MHz	Reading Level dBuV/m	Correct Factor dB	Measure ment dBuV/m	Limit dBuV/m	Margin dB	Detector	Comment
1 *	10480.8850	40.25	13.63	53.88	68.30	-14.42	Peak	

REMARKS:

- (1) Measurement Value = Reading Level + Correct Factor.
- (2) Margin Level = Measurement Value - Limit Value.

Orthogonal Axis	X
Test Mode	UNII-1_TX AC (VHT40) Mode 5190 MHz

Vertical

130 dBuV/m

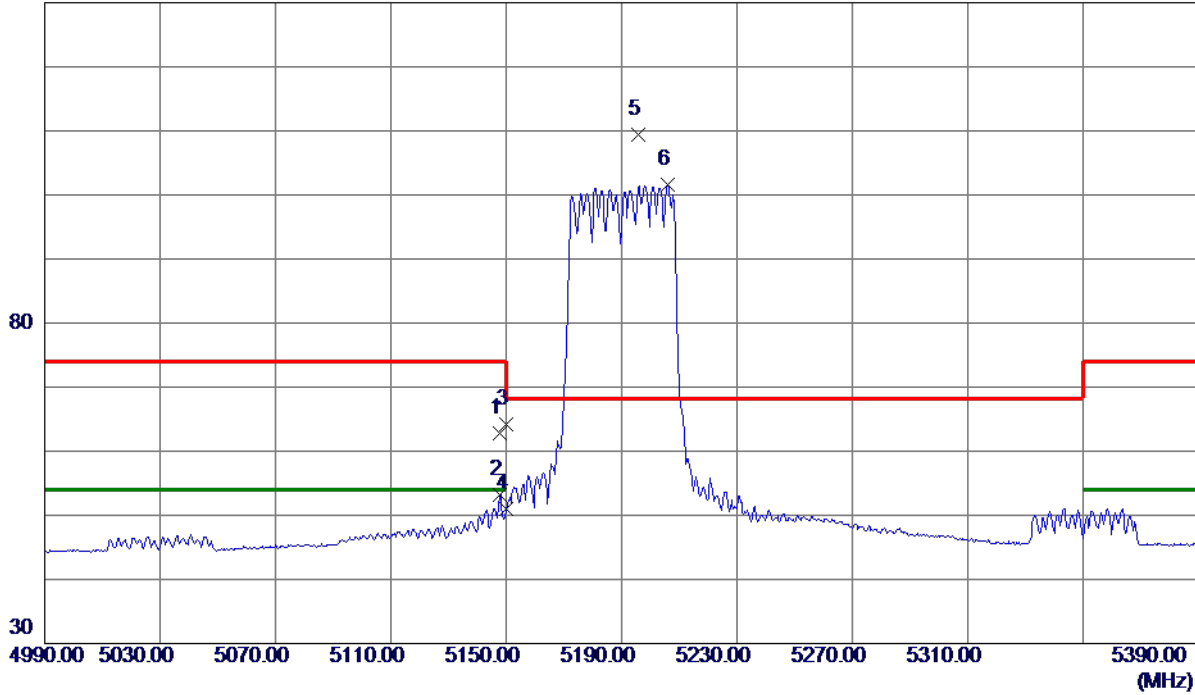

No.	Freq. MHz	Reading Level dBuV/m	Correct Factor dB	Measure ment dBuV/m	Limit dBuV/m	Margin dB	Detector	Comment
1	5147.6000	46.72	16.15	62.87	74.00	-11.13	Peak	
2	5147.6000	37.03	16.15	53.18	54.00	-0.82	AVG	
3	5150.0000	48.03	16.16	64.19	74.00	-9.81	Peak	
4	5150.0000	34.81	16.16	50.97	54.00	-3.03	AVG	
5 *	5195.6000	93.08	16.26	109.34	68.30	41.04	Peak	No Limit
6	5206.0000	85.28	16.29	101.57	999.00	-897.43	AVG	No Limit

REMARKS:

- (1) Measurement Value = Reading Level + Correct Factor.
- (2) Margin Level = Measurement Value - Limit Value.

Orthogonal Axis	X
Test Mode	UNII-1_TX AC (VHT40) Mode 5190 MHz

Vertical

80 dBuV/m

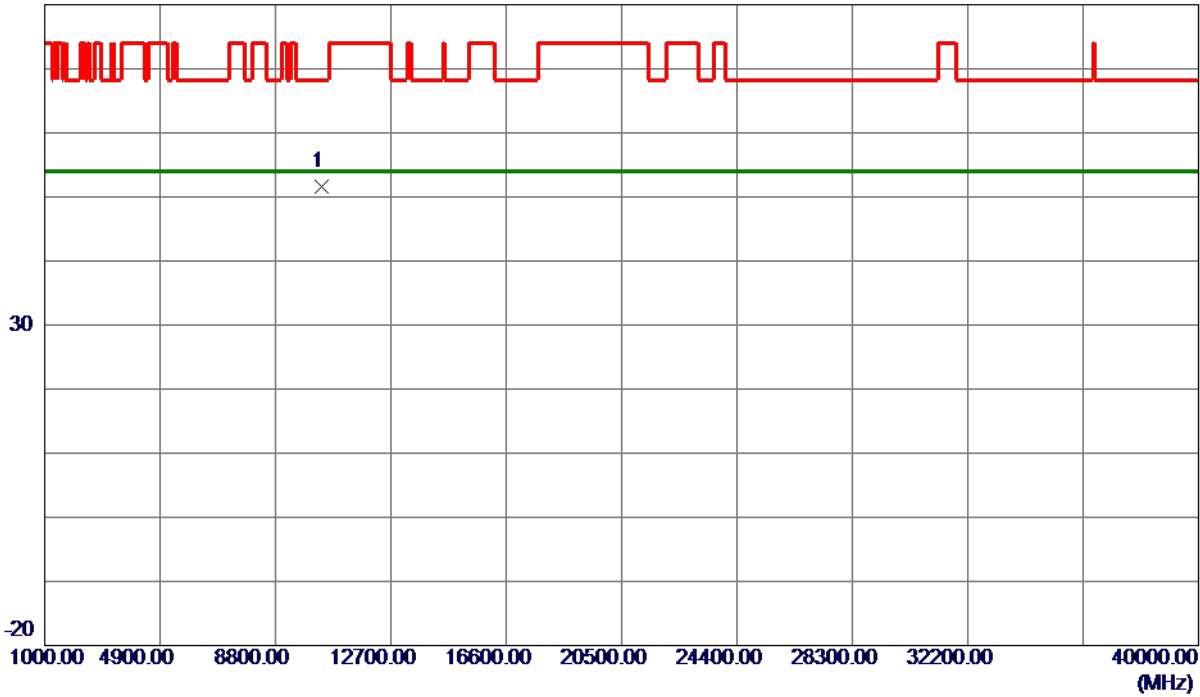

No.	Freq. MHz	Reading Level dBuV/m	Correct Factor dB	Measure ment dBuV/m	Limit dBuV/m	Margin dB	Detector	Comment
1 *	10379.6540	38.12	13.53	51.65	68.30	-16.65	Peak	

REMARKS:

- (1) Measurement Value = Reading Level + Correct Factor.
- (2) Margin Level = Measurement Value - Limit Value.

Orthogonal Axis	X
Test Mode	UNII-1_TX AC (VHT40) Mode 5190 MHz

Horizontal

130 dBuV/m

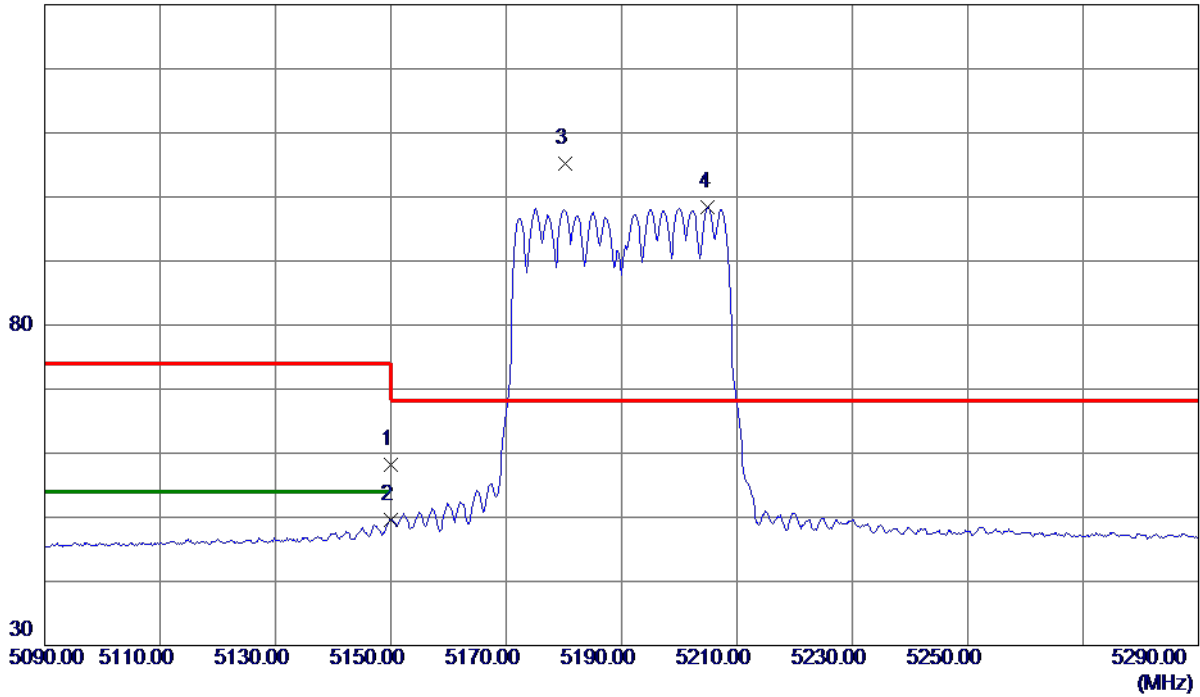

No.	Freq. MHz	Reading Level dBuV/m	Correct Factor dB	Measure ment dBuV/m	Limit dBuV/m	Margin dB	Detector	Comment
1	5150.0000	42.01	16.16	58.17	74.00	-15.83	Peak	
2	5150.0000	33.52	16.16	49.68	54.00	-4.32	AVG	
3 *	5180.2000	89.00	16.23	105.23	68.30	36.93	Peak	No Limit
4	5205.0000	82.11	16.29	98.40	999.00	-900.60	AVG	No Limit

REMARKS:

- (1) Measurement Value = Reading Level + Correct Factor.
- (2) Margin Level = Measurement Value - Limit Value.

Orthogonal Axis	X
Test Mode	UNII-1_TX AC (VHT40) Mode 5190 MHz

Horizontal

80 dBuV/m

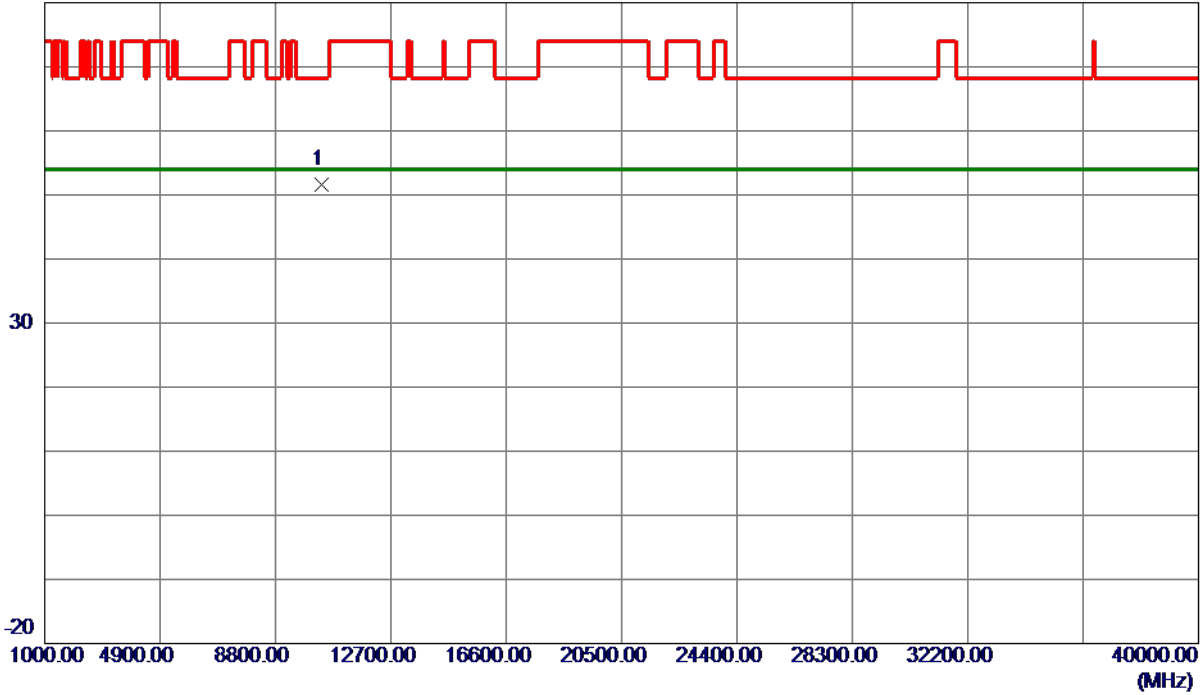

No.	Freq. MHz	Reading Level dBuV/m	Correct Factor dB	Measure ment dBuV/m	Limit dBuV/m	Margin dB	Detector	Comment
1 *	10380.4740	38.06	13.53	51.59	68.30	-16.71	Peak	

REMARKS:

- (1) Measurement Value = Reading Level + Correct Factor.
- (2) Margin Level = Measurement Value - Limit Value.

Orthogonal Axis	X
Test Mode	UNII-1_TX AC (VHT40) Mode 5230 MHz

Vertical

130 dBuV/m

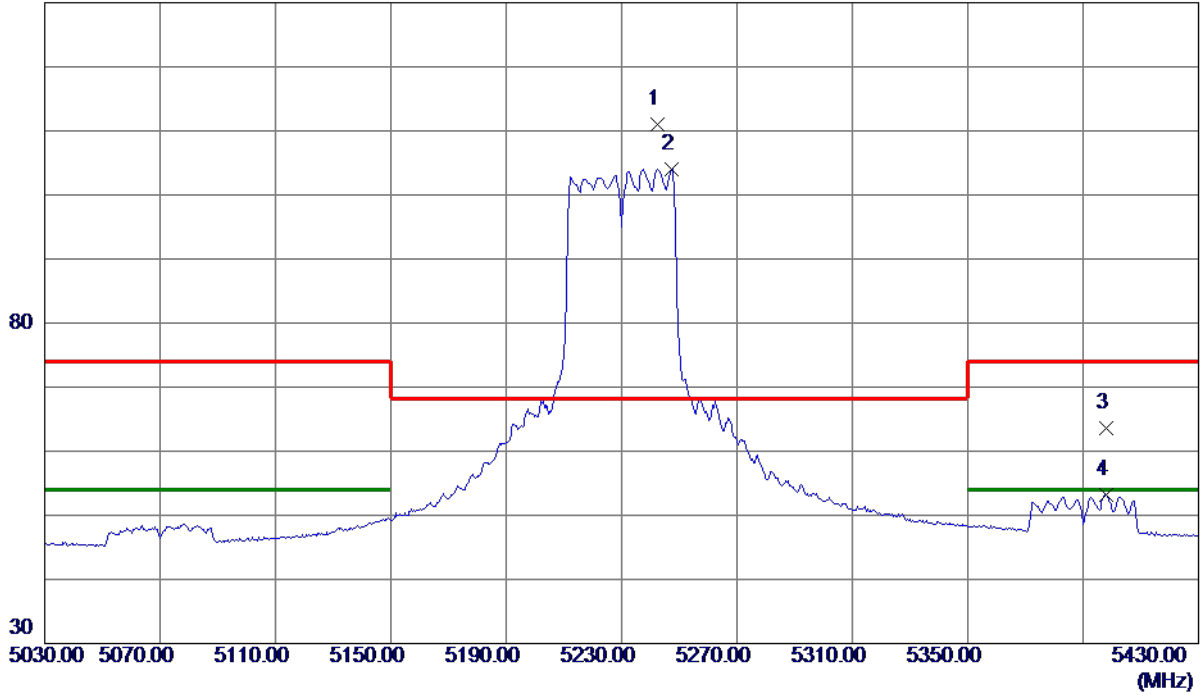

No.	Freq. MHz	Reading Level dBuV/m	Correct Factor dB	Measure ment dBuV/m	Limit dBuV/m	Margin dB	Detector	Comment
1 *	5242.4000	94.61	16.37	110.98	68.30	42.68	Peak	No Limit
2	5247.2000	87.71	16.39	104.10	999.00	-894.90	AVG	No Limit
3	5398.0000	46.92	16.74	63.66	74.00	-10.34	Peak	
4	5398.0000	36.45	16.74	53.19	54.00	-0.81	AVG	

REMARKS:

- (1) Measurement Value = Reading Level + Correct Factor.
- (2) Margin Level = Measurement Value - Limit Value.

Orthogonal Axis	X
Test Mode	UNII-1_TX AC (VHT40) Mode 5230 MHz

Vertical

80 dBuV/m

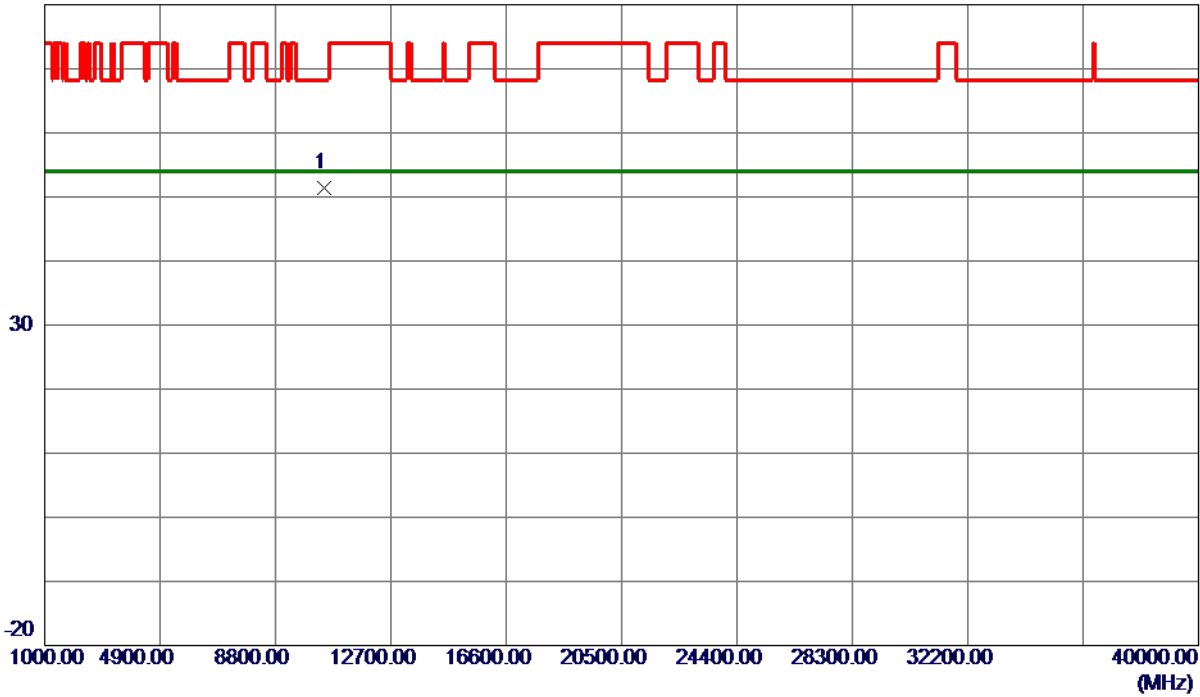

No.	Freq. MHz	Reading Level dBuV/m	Correct Factor dB	Measure ment dBuV/m	Limit dBuV/m	Margin dB	Detector	Comment
1 *	10460.6160	37.81	13.61	51.42	68.30	-16.88	Peak	

REMARKS:

- (1) Measurement Value = Reading Level + Correct Factor.
- (2) Margin Level = Measurement Value - Limit Value.

Orthogonal Axis	X
Test Mode	UNII-1_TX AC (VHT40) Mode 5230 MHz

Horizontal

130 dBuV/m

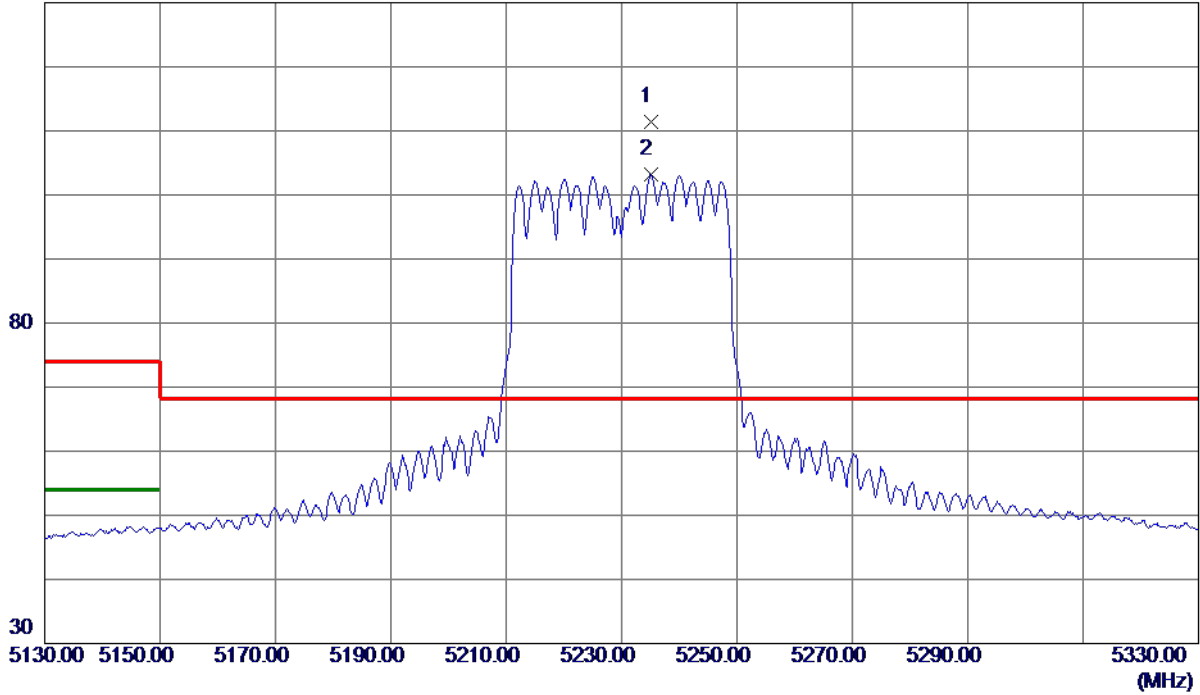

No.	Freq. MHz	Reading Level dBuV/m	Correct Factor dB	Measure ment dBuV/m	Limit dBuV/m	Margin dB	Detector	Comment
1 *	5235.0000	94.99	16.36	111.35	68.30	43.05	Peak	No Limit
2	5235.0000	86.93	16.36	103.29	999.00	-895.71	AVG	No Limit

REMARKS:

- (1) Measurement Value = Reading Level + Correct Factor.
- (2) Margin Level = Measurement Value - Limit Value.

Orthogonal Axis	X
Test Mode	UNII-1_TX AC (VHT40) Mode 5230 MHz

Horizontal

80 dBuV/m

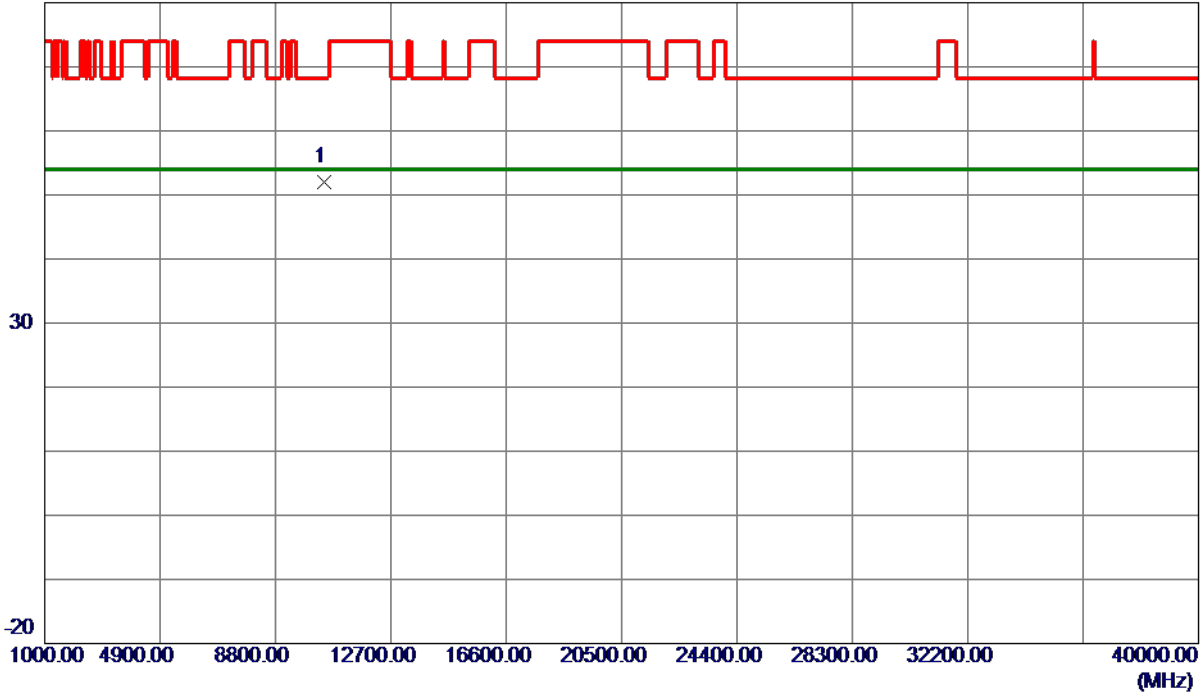

No.	Freq. MHz	Reading Level dBuV/m	Correct Factor dB	Measure ment dBuV/m	Limit dBuV/m	Margin dB	Detector	Comment
1 *	10459.7779	38.48	13.61	52.09	68.30	-16.21	Peak	

REMARKS:

- (1) Measurement Value = Reading Level + Correct Factor.
- (2) Margin Level = Measurement Value - Limit Value.

Orthogonal Axis	X
Test Mode	UNII-1_TX AC (VHT80) Mode 5210 MHz

Vertical

130 dBuV/m

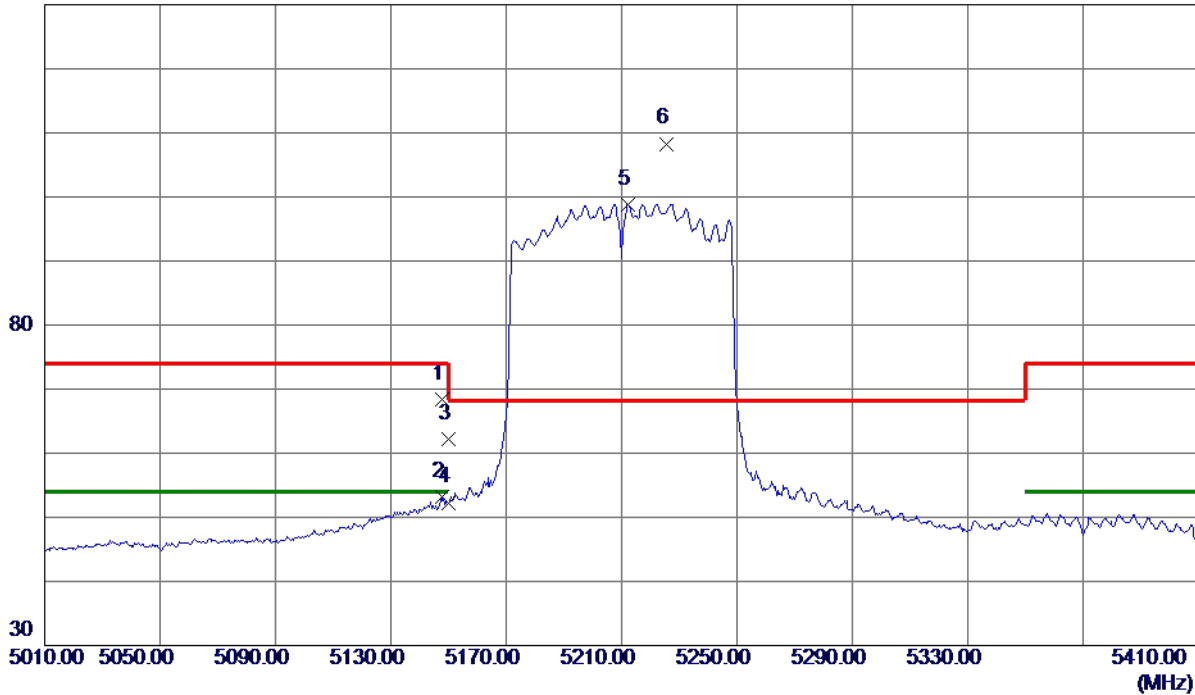

No.	Freq. MHz	Reading Level dBuV/m	Correct Factor dB	Measure ment dBuV/m	Limit dBuV/m	Margin dB	Detector	Comment
1	5147.6000	52.23	16.15	68.38	74.00	-5.62	Peak	
2	5147.6000	37.08	16.15	53.23	54.00	-0.77	AVG	
3	5150.0000	46.03	16.16	62.19	74.00	-11.81	Peak	
4	5150.0000	36.14	16.16	52.30	54.00	-1.70	AVG	
5	5212.4000	82.58	16.30	98.88	999.00	-900.12	AVG	No Limit
6 *	5225.6000	91.97	16.33	108.30	68.30	40.00	Peak	No Limit

REMARKS:

- (1) Measurement Value = Reading Level + Correct Factor.
- (2) Margin Level = Measurement Value - Limit Value.

Orthogonal Axis	X
Test Mode	UNII-1_TX AC (VHT80) Mode 5210 MHz

Vertical

80 dBuV/m



No.	Freq. MHz	Reading Level dBuV/m	Correct Factor dB	Measure ment dBuV/m	Limit dBuV/m	Margin dB	Detector	Comment
1 *	10419.2420	38.69	13.57	52.26	68.30	-16.04	Peak	

REMARKS:

- (1) Measurement Value = Reading Level + Correct Factor.
- (2) Margin Level = Measurement Value - Limit Value.

Orthogonal Axis	X
Test Mode	UNII-1_TX AC (VHT80) Mode 5210 MHz

Horizontal

130 dBuV/m

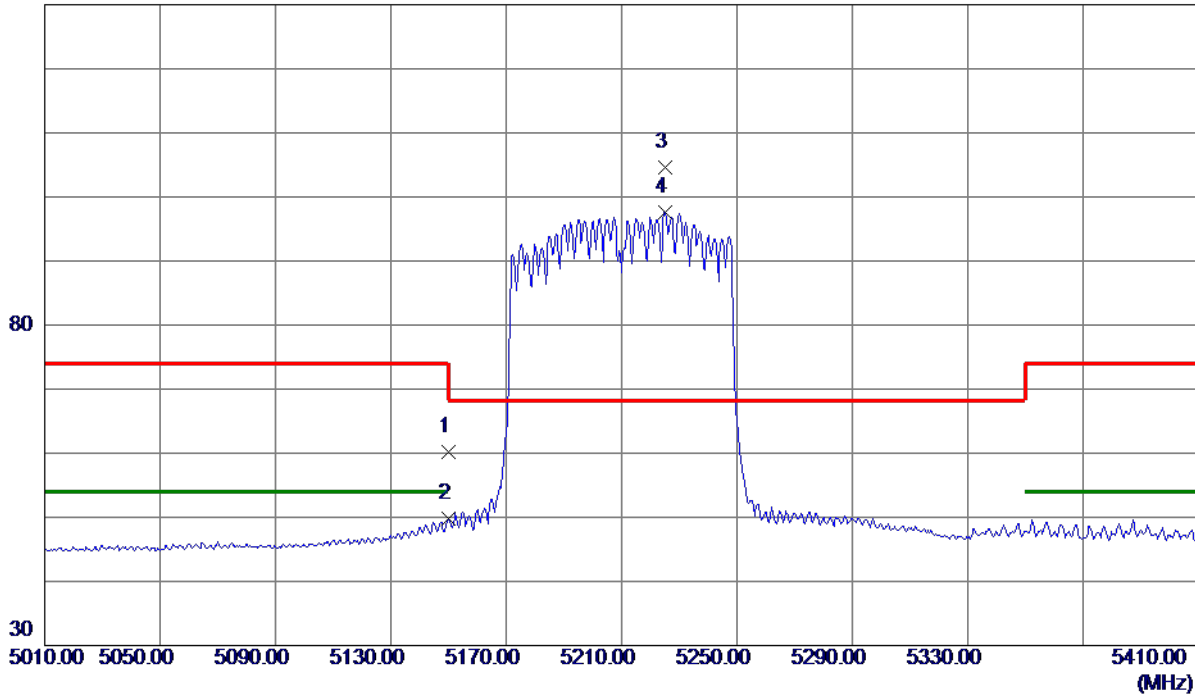

No.	Freq. MHz	Reading Level dBuV/m	Correct Factor dB	Measure ment dBuV/m	Limit dBuV/m	Margin dB	Detector	Comment
1	5150.0000	44.08	16.16	60.24	74.00	-13.76	Peak	
2	5150.0000	33.72	16.16	49.88	54.00	-4.12	AVG	
3 *	5225.2000	88.20	16.33	104.53	68.30	36.23	Peak	No Limit
4	5225.2000	81.28	16.33	97.61	999.00	-901.39	AVG	No Limit

REMARKS:

- (1) Measurement Value = Reading Level + Correct Factor.
- (2) Margin Level = Measurement Value - Limit Value.

Orthogonal Axis	X
Test Mode	UNII-1_TX AC (VHT80) Mode 5210 MHz

Horizontal

80 dBuV/m

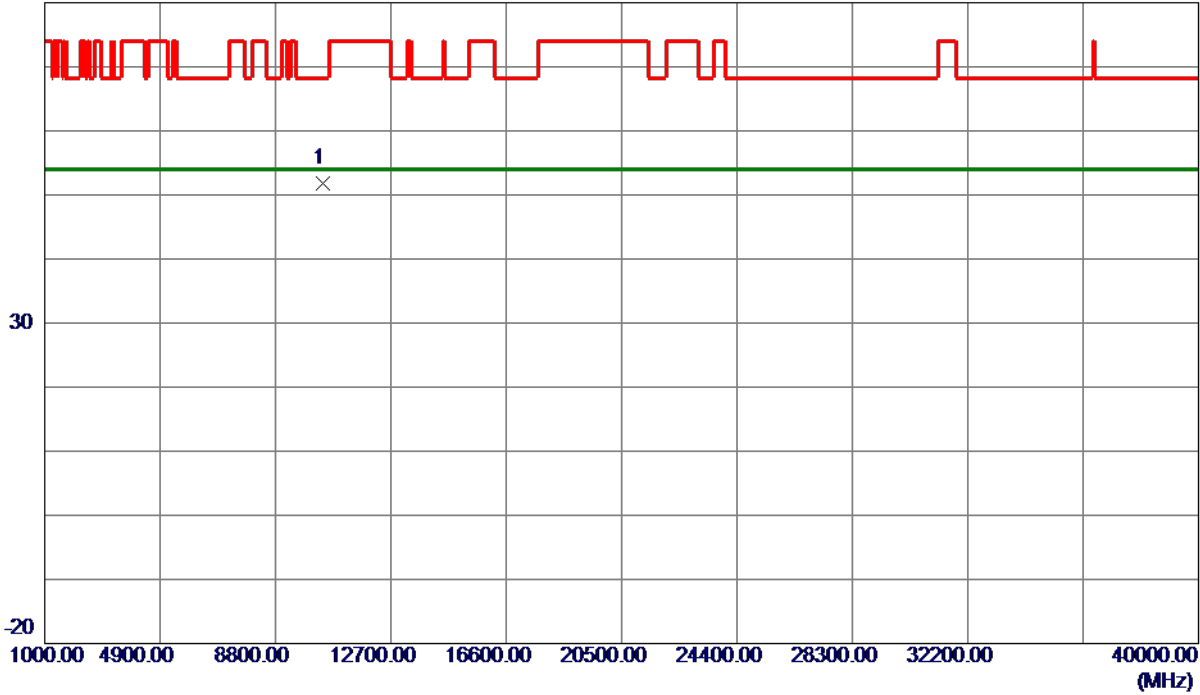

No.	Freq. MHz	Reading Level dBuV/m	Correct Factor dB	Measure ment dBuV/m	Limit dBuV/m	Margin dB	Detector	Comment
1 *	10419.3940	38.21	13.57	51.78	68.30	-16.52	Peak	

REMARKS:

- (1) Measurement Value = Reading Level + Correct Factor.
- (2) Margin Level = Measurement Value - Limit Value.

Orthogonal Axis	X
Test Mode	UNII-2A_TX AC (VHT20) Mode 5260 MHz

Vertical

130 dBuV/m

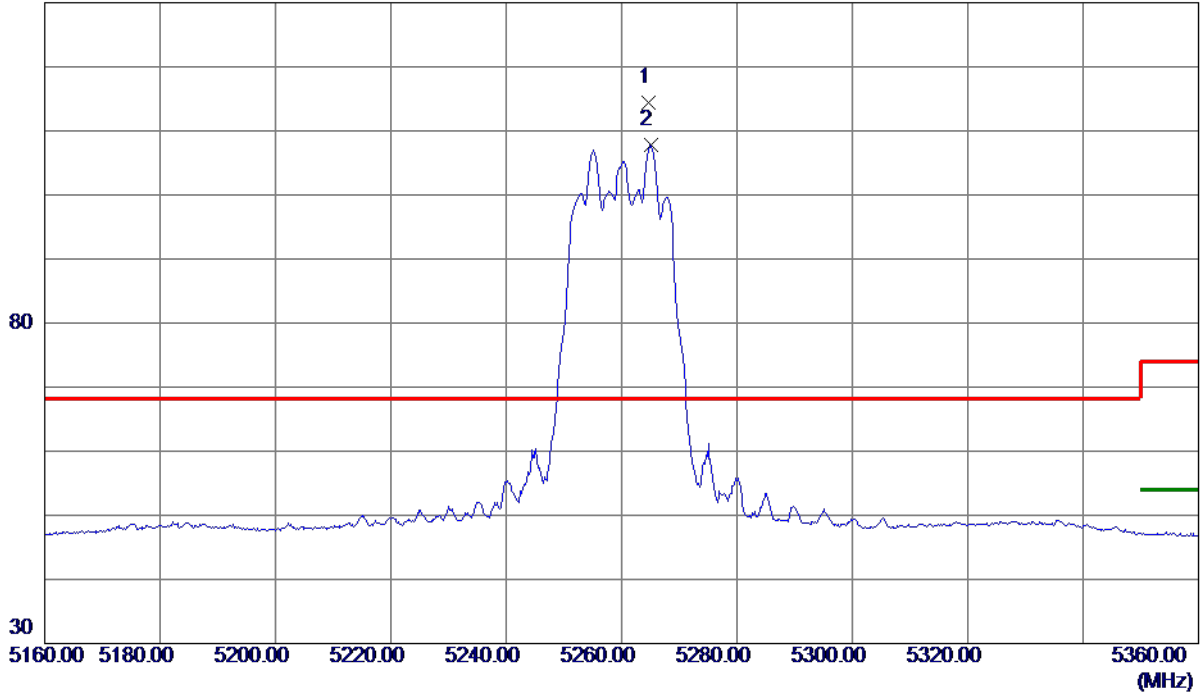

No.	Freq. MHz	Reading Level dBuV/m	Correct Factor dB	Measure ment dBuV/m	Limit dBuV/m	Margin dB	Detector	Comment
1 *	5264.6000	97.99	16.43	114.42	68.30	46.12	Peak	No Limit
2	5265.0000	91.38	16.43	107.81	999.00	-891.19	AVG	No Limit

REMARKS:

- (1) Measurement Value = Reading Level + Correct Factor.
- (2) Margin Level = Measurement Value - Limit Value.

Orthogonal Axis	X
Test Mode	UNII-2A_TX AC (VHT20) Mode 5260 MHz

Vertical

80 dBuV/m

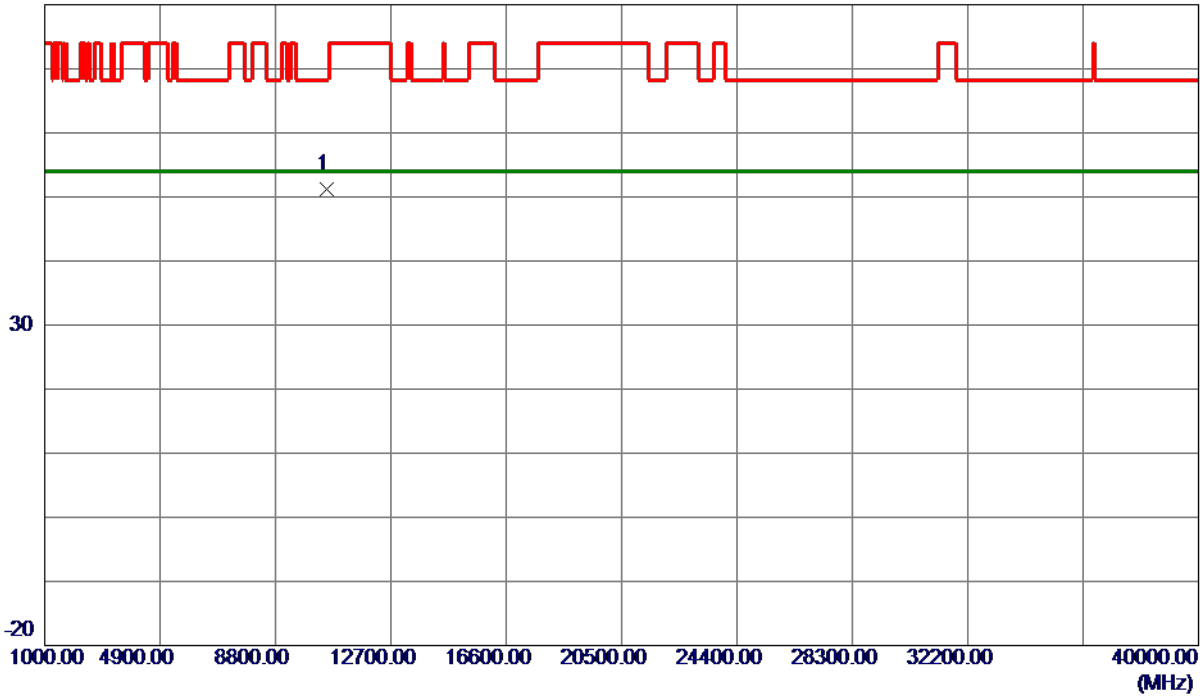

No.	Freq. MHz	Reading Level dBuV/m	Correct Factor dB	Measure ment dBuV/m	Limit dBuV/m	Margin dB	Detector	Comment
1 *	10519.0000	37.56	13.66	51.22	68.30	-17.08	Peak	

REMARKS:

- (1) Measurement Value = Reading Level + Correct Factor.
- (2) Margin Level = Measurement Value - Limit Value.

Orthogonal Axis	X
Test Mode	UNII-2A_TX AC (VHT20) Mode 5260 MHz

Horizontal

130 dBuV/m

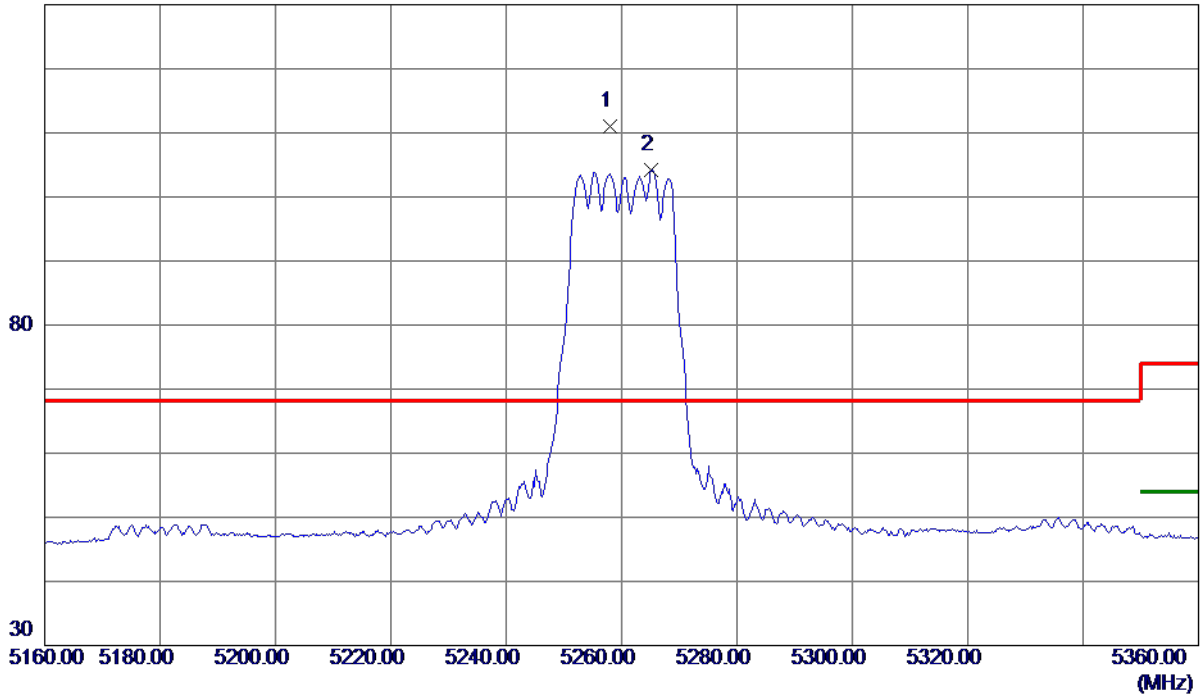

No.	Freq. MHz	Reading Level dBuV/m	Correct Factor dB	Measure ment dBuV/m	Limit dBuV/m	Margin dB	Detector	Comment
1 *	5258.0000	94.55	16.41	110.96	68.30	42.66	Peak	No Limit
2	5265.2000	87.81	16.43	104.24	999.00	-894.76	AVG	No Limit

REMARKS:

- (1) Measurement Value = Reading Level + Correct Factor.
- (2) Margin Level = Measurement Value - Limit Value.

Orthogonal Axis	X
Test Mode	UNII-2A_TX AC (VHT20) Mode 5260 MHz

Horizontal

80 dBuV/m

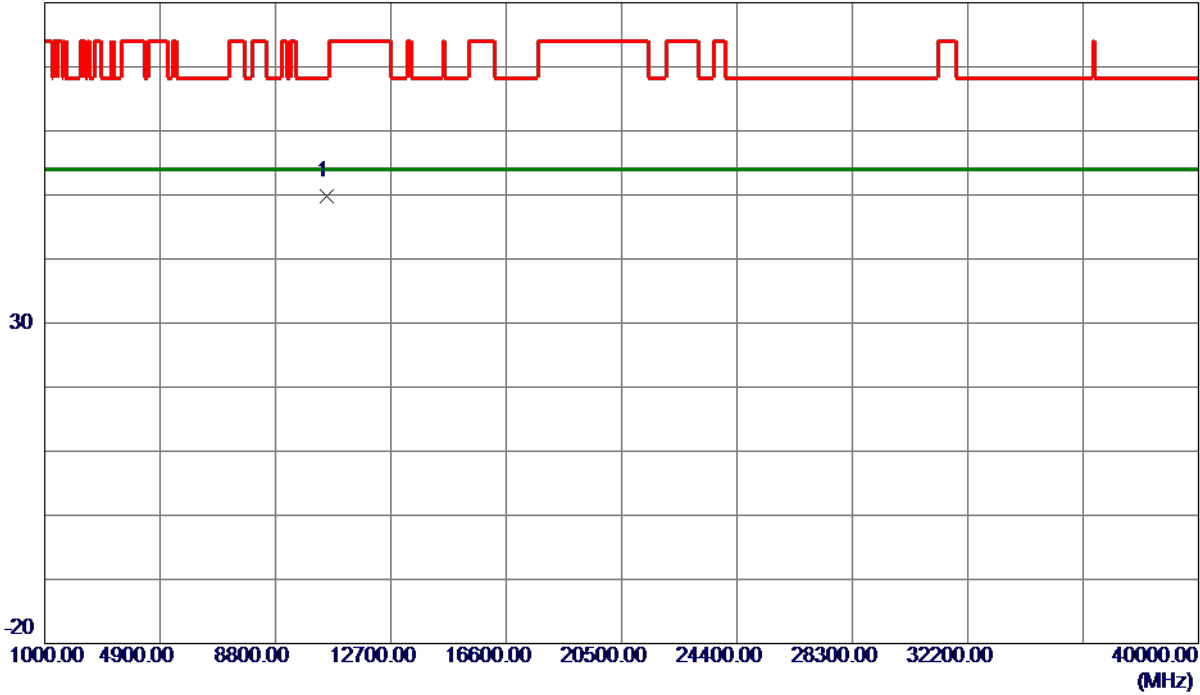

No.	Freq. MHz	Reading Level dBuV/m	Correct Factor dB	Measure ment dBuV/m	Limit dBuV/m	Margin dB	Detector	Comment
1 *	10522.2550	36.20	13.66	49.86	68.30	-18.44	Peak	

REMARKS:

- (1) Measurement Value = Reading Level + Correct Factor.
- (2) Margin Level = Measurement Value - Limit Value.

Orthogonal Axis	X
Test Mode	UNII-2A_TX AC (VHT20) Mode 5300 MHz

Vertical

130 dBuV/m

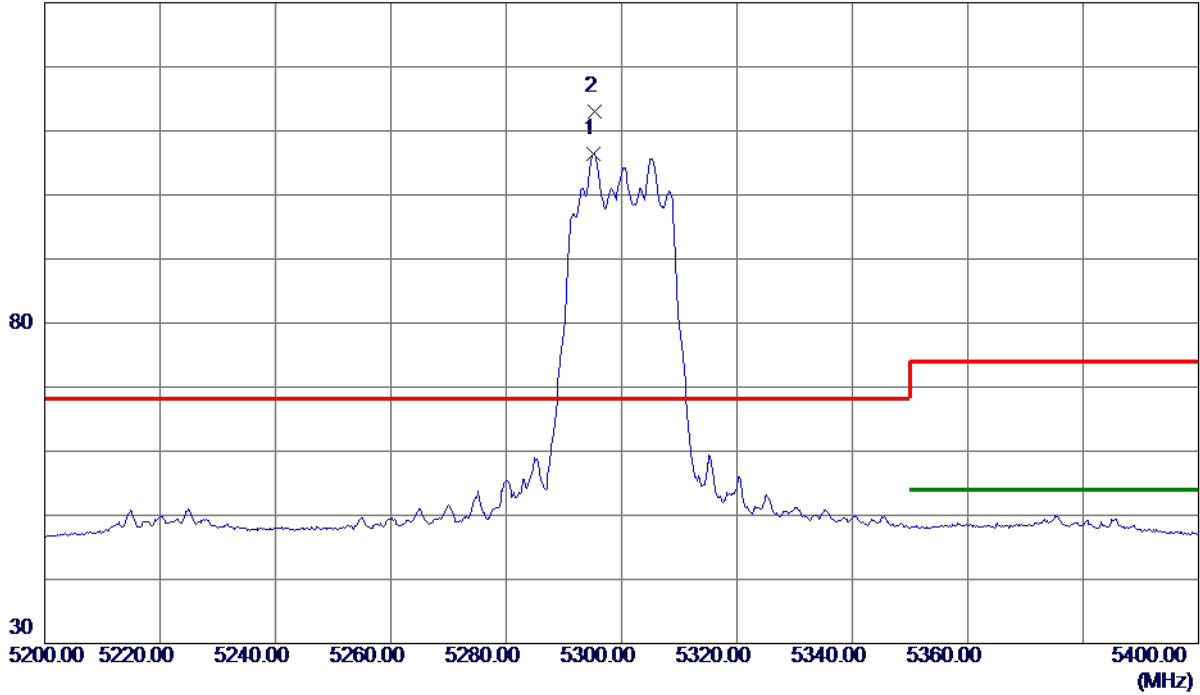

No.	Freq. MHz	Reading Level dBuV/m	Correct Factor dB	Measure ment dBuV/m	Limit dBuV/m	Margin dB	Detector	Comment
1	5295.2000	89.99	16.50	106.49	999.00	-892.51	AVG	No Limit
2 *	5295.4000	96.60	16.50	113.10	68.30	44.80	Peak	No Limit

REMARKS:

- (1) Measurement Value = Reading Level + Correct Factor.
- (2) Margin Level = Measurement Value - Limit Value.

Orthogonal Axis	X
Test Mode	UNII-2A_TX AC (VHT20) Mode 5300 MHz

Vertical

80 dBuV/m

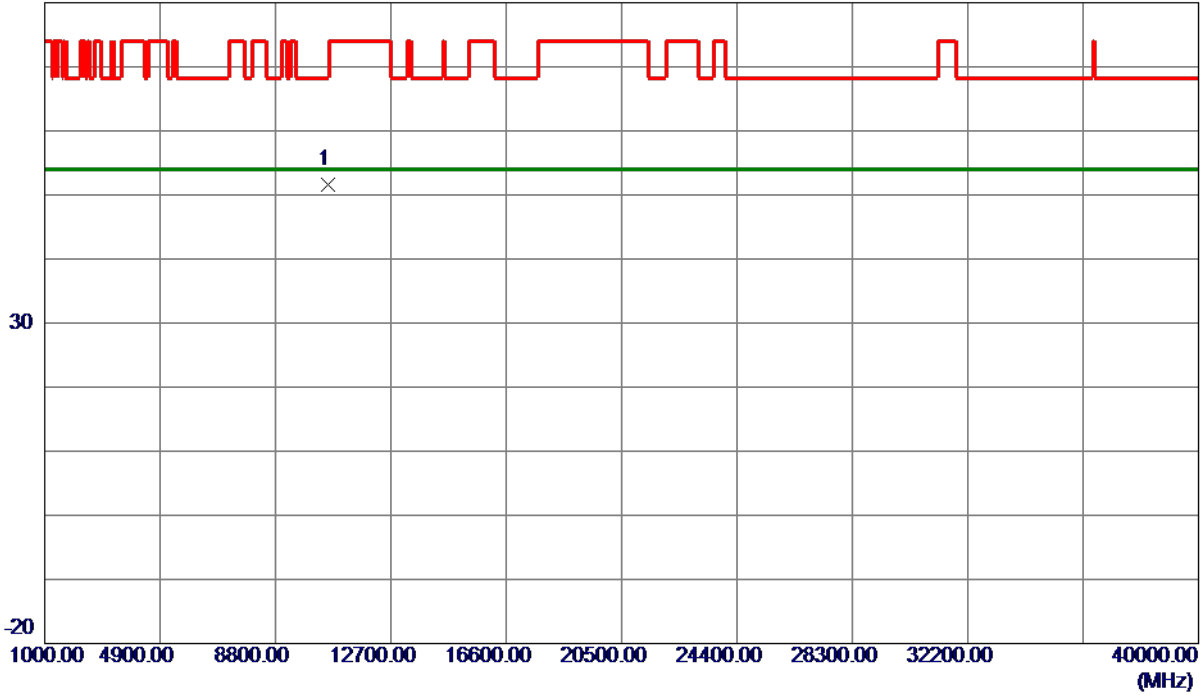

No.	Freq. MHz	Reading Level dBuV/m	Correct Factor dB	Measure ment dBuV/m	Limit dBuV/m	Margin dB	Detector	Comment
1 *	10597.6550	37.84	13.70	51.54	68.30	-16.76	Peak	

REMARKS:

- (1) Measurement Value = Reading Level + Correct Factor.
- (2) Margin Level = Measurement Value - Limit Value.

Orthogonal Axis	X
Test Mode	UNII-2A_TX AC (VHT20) Mode 5300 MHz

Horizontal

130 dBuV/m

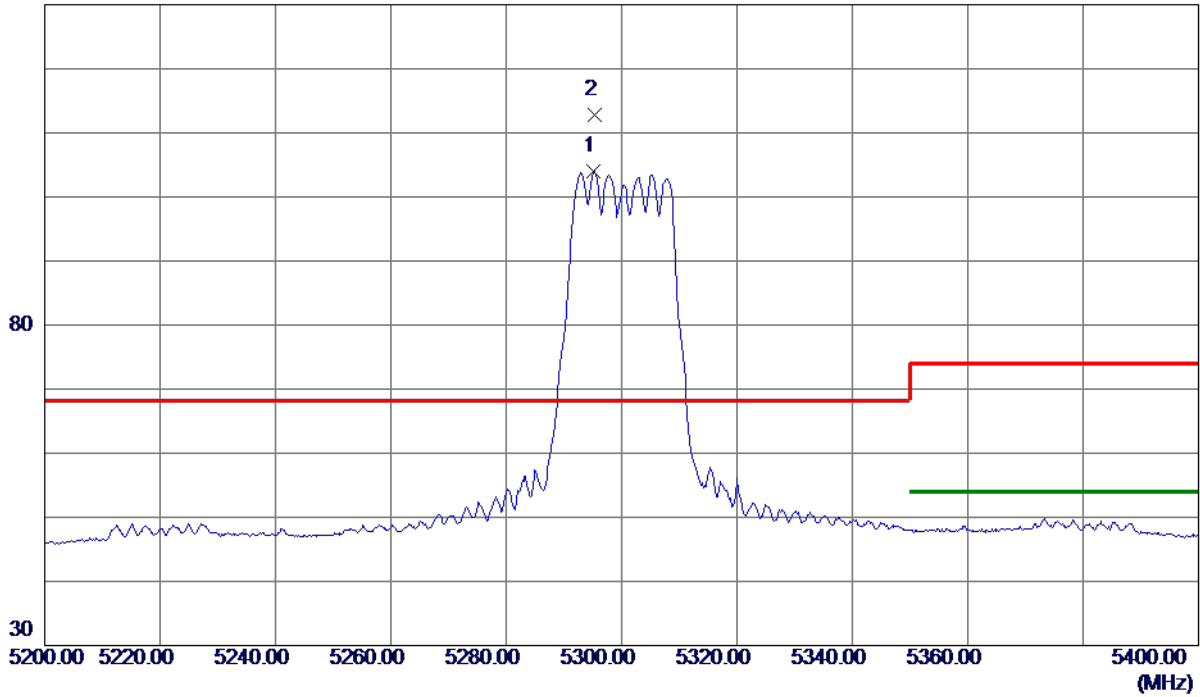

No.	Freq. MHz	Reading Level dBuV/m	Correct Factor dB	Measure ment dBuV/m	Limit dBuV/m	Margin dB	Detector	Comment
1	5295.2000	87.52	16.50	104.02	999.00	-894.98	AVG	No Limit
2 *	5295.4000	96.34	16.50	112.84	68.30	44.54	Peak	No Limit

REMARKS:

- (1) Measurement Value = Reading Level + Correct Factor.
- (2) Margin Level = Measurement Value - Limit Value.

Orthogonal Axis	X
Test Mode	UNII-2A_TX AC (VHT20) Mode 5300 MHz

Horizontal

80 dBuV/m

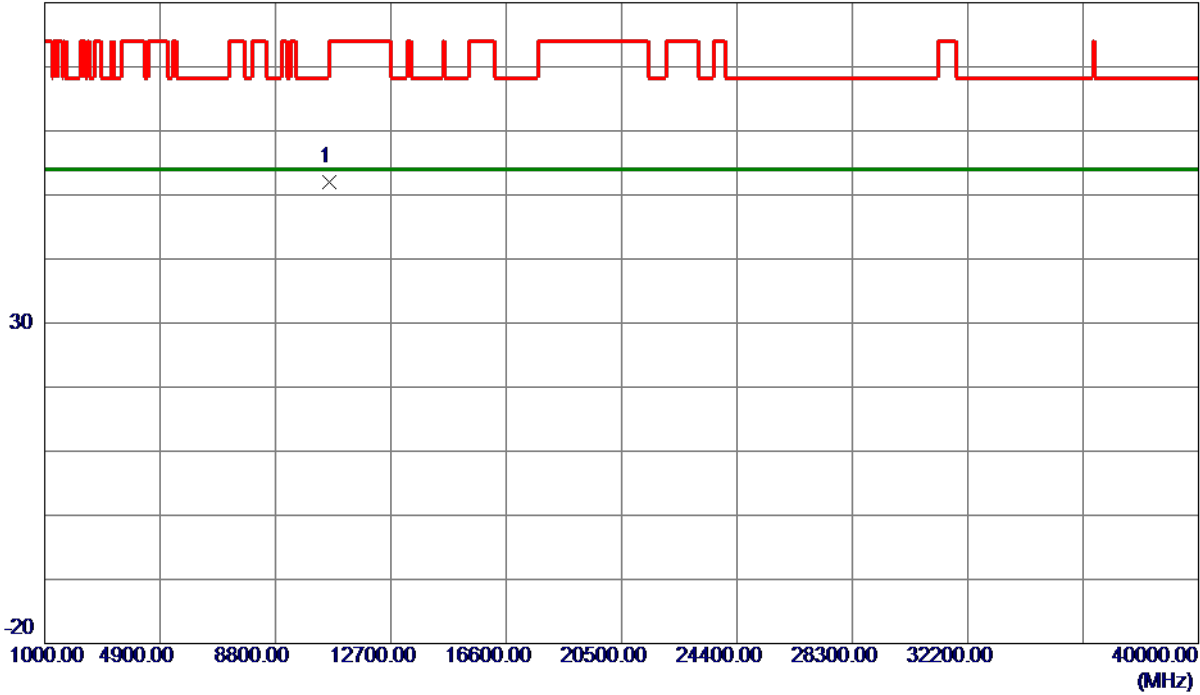

No.	Freq. MHz	Reading Level dBuV/m	Correct Factor dB	Measure ment dBuV/m	Limit dBuV/m	Margin dB	Detector	Comment
1 *	10599.9050	38.21	13.70	51.91	68.30	-16.39	Peak	

REMARKS:

- (1) Measurement Value = Reading Level + Correct Factor.
- (2) Margin Level = Measurement Value - Limit Value.

Orthogonal Axis	X
Test Mode	UNII-2A_TX AC (VHT20) Mode 5320 MHz

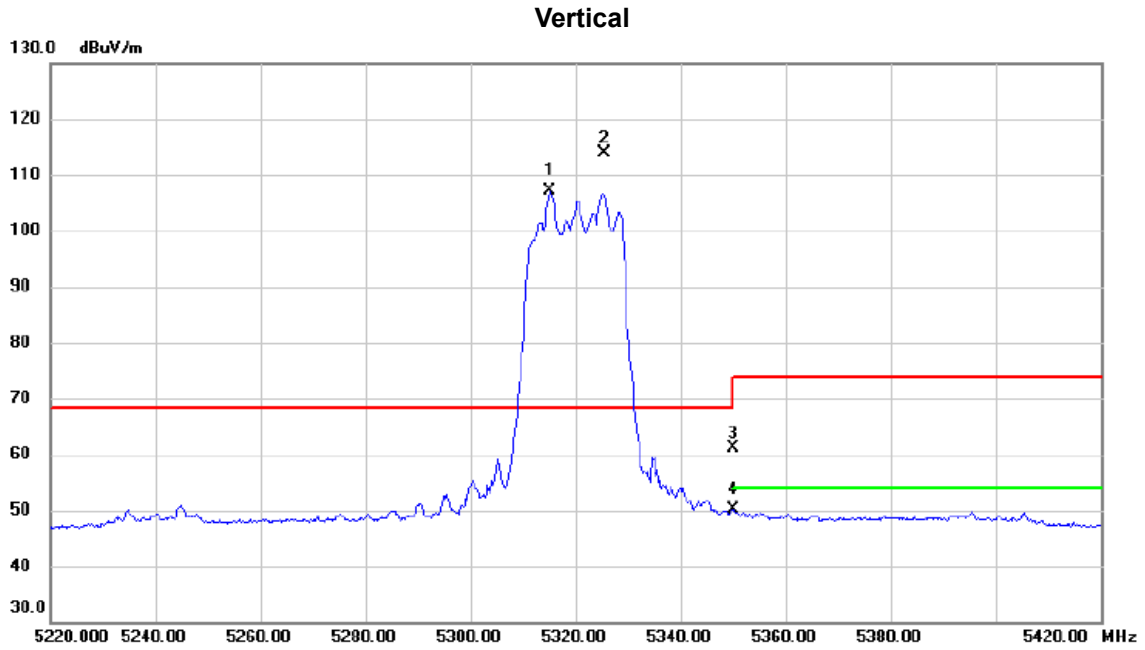

No.	Mk.	Freq. MHz	Reading Level dBuV	Correct Factor dB	Measure- ment dBuV/m	Limit dBuV/m	Margin dB	Detector	Comment
1	X	5315.200	90.46	16.55	107.01	68.30	38.71	AVG	No Limit
2	*	5325.400	97.24	16.57	113.81	68.30	45.51	peak	No Limit
3		5350.000	44.62	16.63	61.25	74.00	-12.75	peak	
4		5350.000	33.56	16.63	50.19	54.00	-3.81	AVG	

REMARKS:

- (1) Measurement Value = Reading Level + Correct Factor.
- (2) Margin Level = Measurement Value - Limit Value.

Orthogonal Axis	X
Test Mode	UNII-2A_TX AC (VHT20) Mode 5320 MHz

Vertical

80 dBuV/m

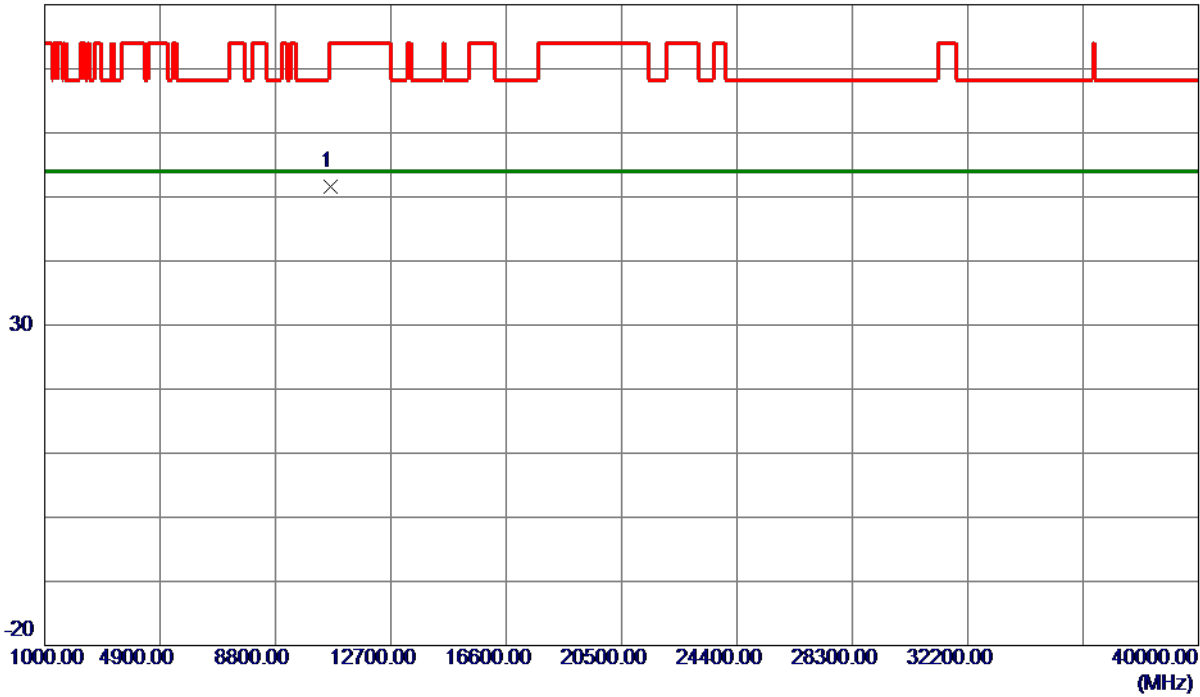

No.	Freq. MHz	Reading Level dBuV/m	Correct Factor dB	Measure ment dBuV/m	Limit dBuV/m	Margin dB	Detector	Comment
1 *	10642.0250	37.97	13.72	51.69	74.00	-22.31	Peak	

REMARKS:

- (1) Measurement Value = Reading Level + Correct Factor.
- (2) Margin Level = Measurement Value - Limit Value.

Orthogonal Axis	X
Test Mode	UNII-2A_TX AC (VHT20) Mode 5320 MHz

Horizontal

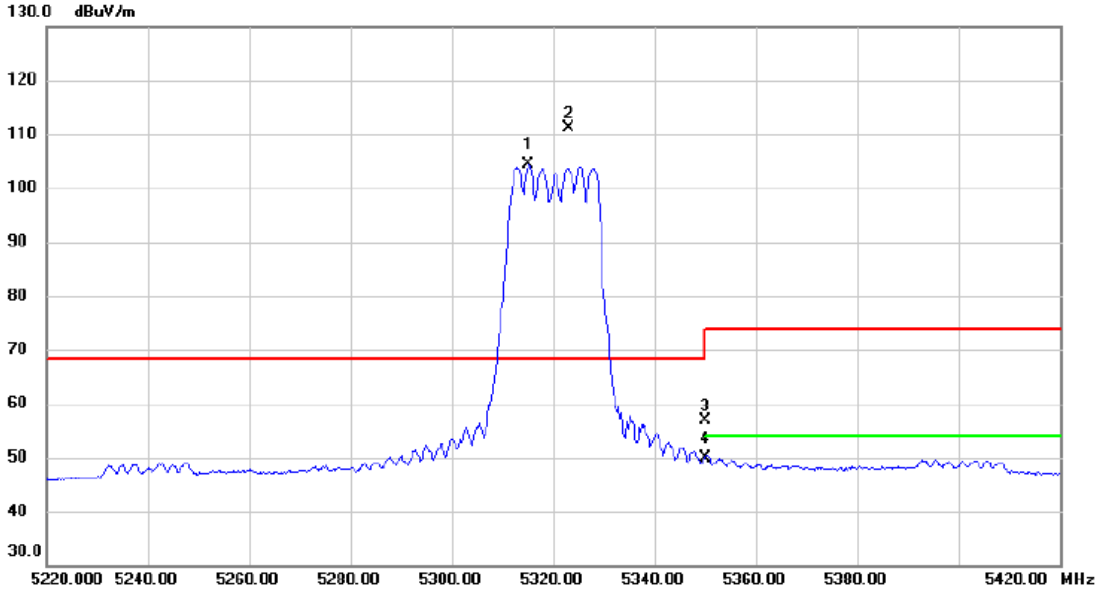

No.	Mk.	Freq. MHz	Reading Level dBuV	Correct Factor dB	Measure- ment dBuV/m	Limit dBuV/m	Margin dB	Detector	Comment
1	X	5315.200	87.87	16.55	104.42	68.30	36.12	AVG	No Limit
2	*	5323.000	94.64	16.56	111.20	68.30	42.90	peak	No Limit
3		5350.000	40.14	16.63	56.77	74.00	-17.23	peak	
4		5350.000	33.24	16.63	49.87	54.00	-4.13	AVG	

REMARKS:

- (1) Measurement Value = Reading Level + Correct Factor.
- (2) Margin Level = Measurement Value - Limit Value.

Orthogonal Axis	X
Test Mode	UNII-2A_TX AC (VHT20) Mode 5320 MHz

Horizontal

80 dBuV/m

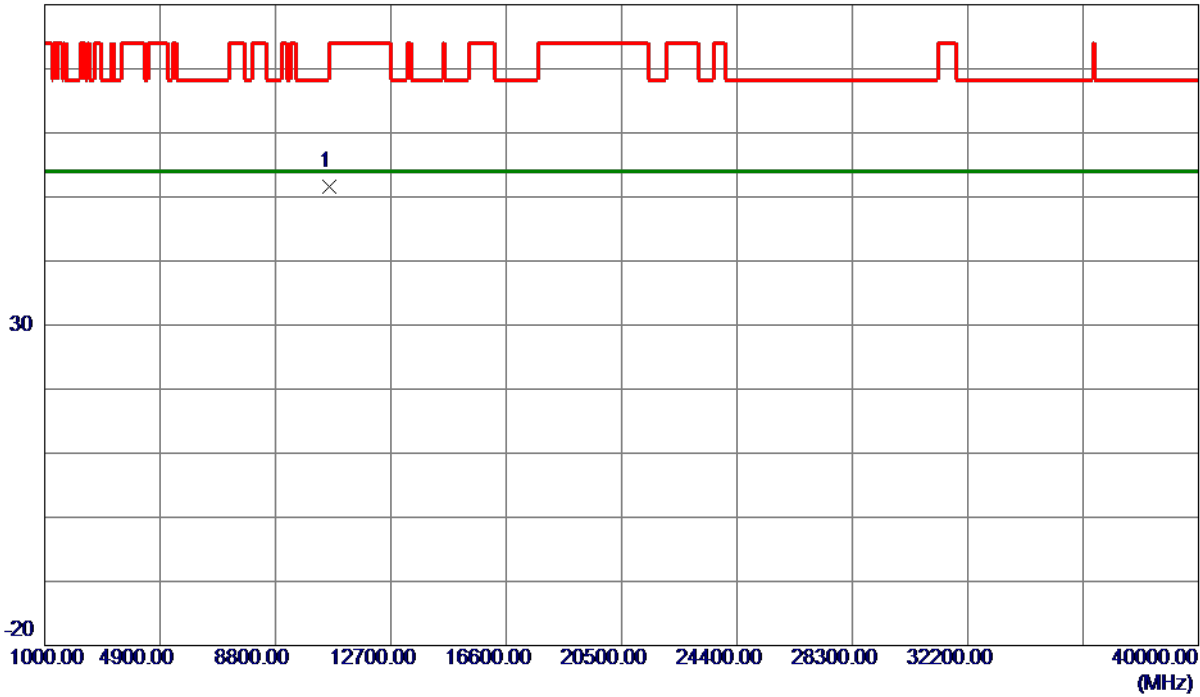

No.	Freq. MHz	Reading Level dBuV/m	Correct Factor dB	Measure ment dBuV/m	Limit dBuV/m	Margin dB	Detector	Comment
1 *	10639.0150	37.83	13.72	51.55	74.00	-22.45	Peak	

REMARKS:

- (1) Measurement Value = Reading Level + Correct Factor.
- (2) Margin Level = Measurement Value - Limit Value.

Orthogonal Axis	X
Test Mode	UNII-2A_TX AC (VHT40) Mode 5270 MHz

Vertical

130 dBuV/m

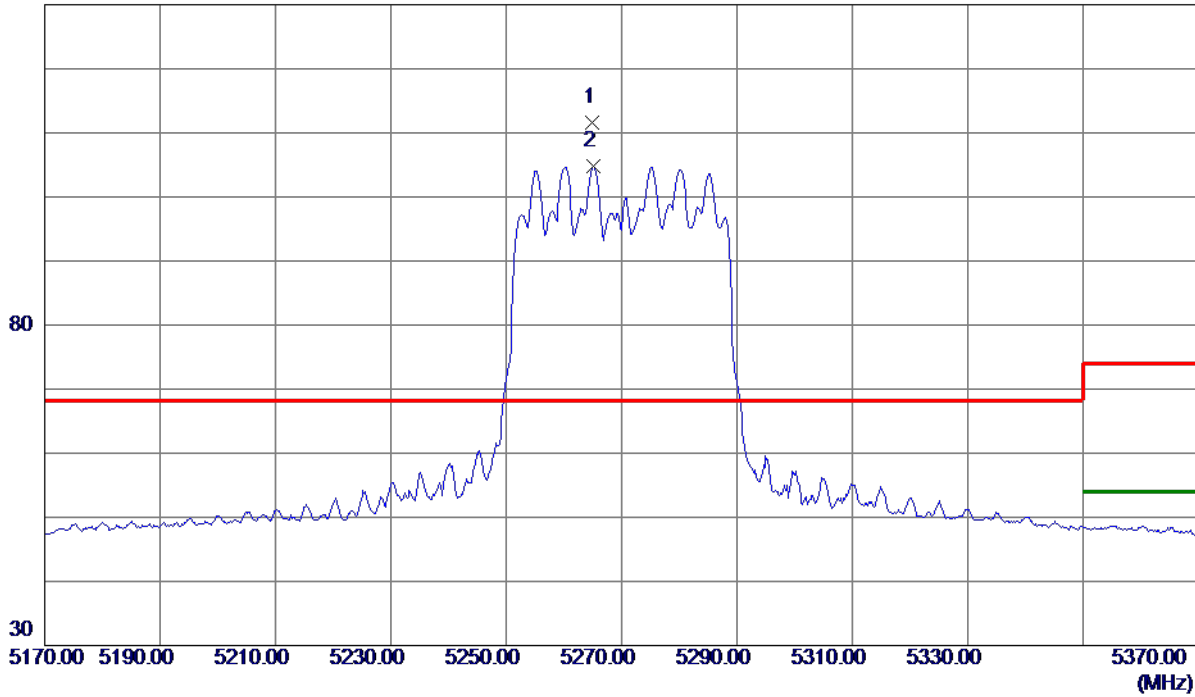

No.	Freq. MHz	Reading Level dBuV/m	Correct Factor dB	Measure ment dBuV/m	Limit dBuV/m	Margin dB	Detector	Comment
1 *	5265.0000	95.08	16.43	111.51	68.30	43.21	Peak	No Limit
2	5265.2000	88.39	16.43	104.82	999.00	-894.18	AVG	No Limit

REMARKS:

- (1) Measurement Value = Reading Level + Correct Factor.
- (2) Margin Level = Measurement Value - Limit Value.

Orthogonal Axis	X
Test Mode	UNII-2A_TX AC (VHT40) Mode 5270 MHz

Vertical

80 dBuV/m

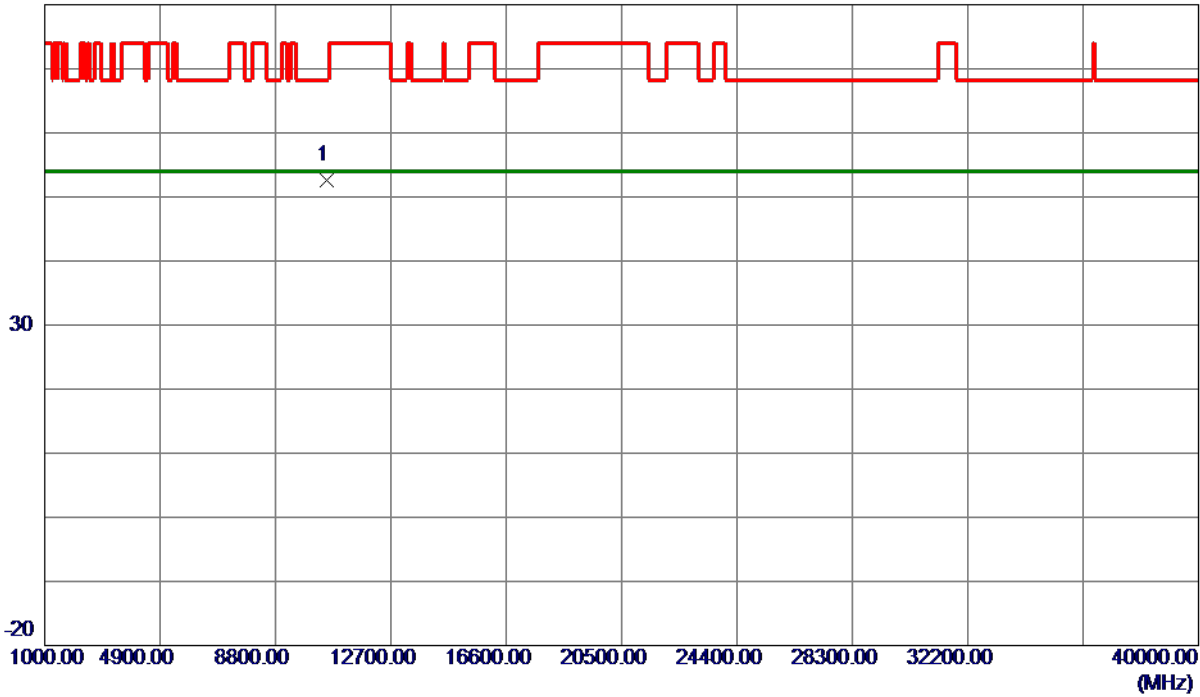

No.	Freq. MHz	Reading Level dBuV/m	Correct Factor dB	Measure ment dBuV/m	Limit dBuV/m	Margin dB	Detector	Comment
1 *	10540.3840	38.85	13.67	52.52	68.30	-15.78	Peak	

REMARKS:

- (1) Measurement Value = Reading Level + Correct Factor.
- (2) Margin Level = Measurement Value - Limit Value.

Orthogonal Axis	X
Test Mode	UNII-2A_TX AC (VHT40) Mode 5270 MHz

Horizontal

130 dBuV/m

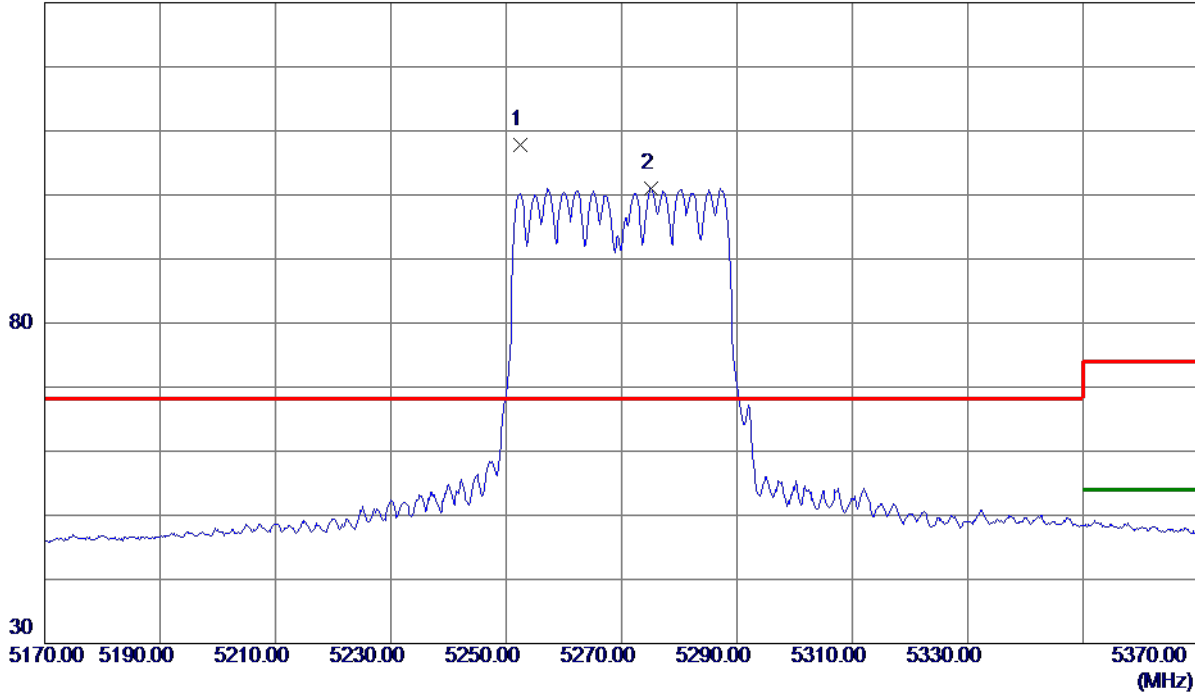

No.	Freq. MHz	Reading Level dBuV/m	Correct Factor dB	Measure ment dBuV/m	Limit dBuV/m	Margin dB	Detector	Comment
1 *	5252.4000	91.43	16.40	107.83	68.30	39.53	Peak	No Limit
2	5275.2000	84.61	16.45	101.06	999.00	-897.94	AVG	No Limit

REMARKS:

- (1) Measurement Value = Reading Level + Correct Factor.
- (2) Margin Level = Measurement Value - Limit Value.

Orthogonal Axis	X
Test Mode	UNII-2A_TX AC (VHT40) Mode 5270 MHz

Horizontal

80 dBuV/m



No.	Freq. MHz	Reading Level dBuV/m	Correct Factor dB	Measure ment dBuV/m	Limit dBuV/m	Margin dB	Detector	Comment
1 *	10540.7340	37.86	13.67	51.53	68.30	-16.77	Peak	

REMARKS:

- (1) Measurement Value = Reading Level + Correct Factor.
- (2) Margin Level = Measurement Value - Limit Value.

Orthogonal Axis	X
Test Mode	UNII-2A_TX AC (VHT40) Mode 5310 MHz

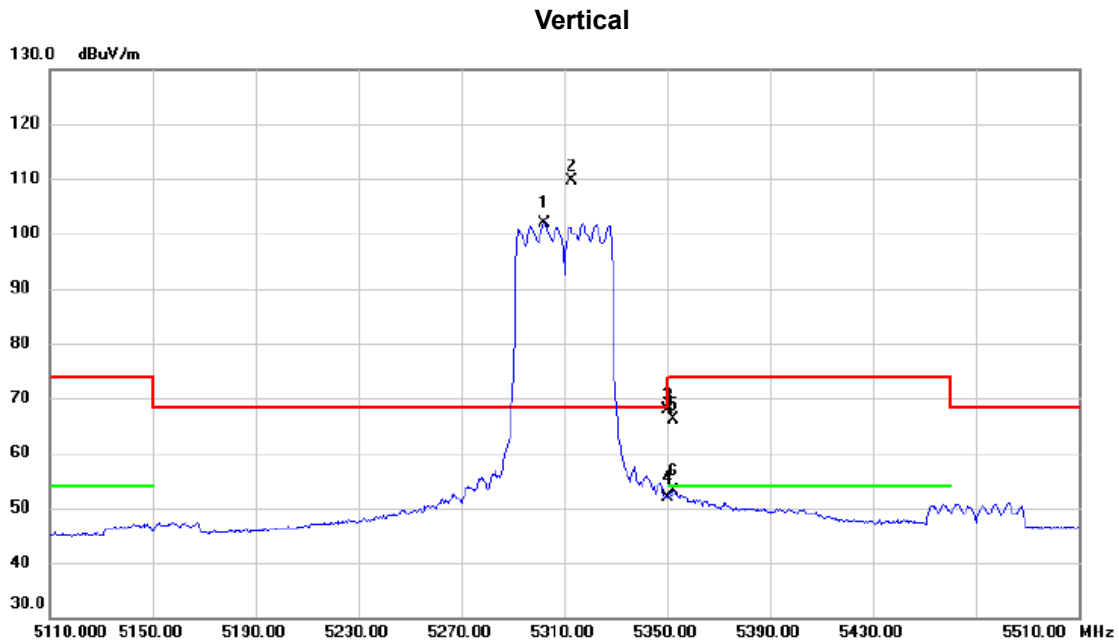

No.	Mk.	Freq. MHz	Reading Level dBuV	Correct Factor dB	Measure- ment dBuV/m	Limit dBuV/m	Margin dB	Detector	Comment
1	X	5302.000	85.47	16.51	101.98	68.30	33.68	AVG	No Limit
2	*	5312.800	93.08	16.53	109.61	68.30	41.31	peak	No Limit
3		5350.000	51.37	16.63	68.00	74.00	-6.00	peak	
4		5350.000	35.17	16.63	51.80	54.00	-2.20	AVG	
5		5352.400	49.40	16.63	66.03	74.00	-7.97	peak	
6		5352.400	36.53	16.63	53.16	54.00	-0.84	AVG	

REMARKS:

- (1) Measurement Value = Reading Level + Correct Factor.
- (2) Margin Level = Measurement Value - Limit Value.

Orthogonal Axis	X
Test Mode	UNII-2A_TX AC (VHT40) Mode 5310 MHz

Vertical

80 dBuV/m

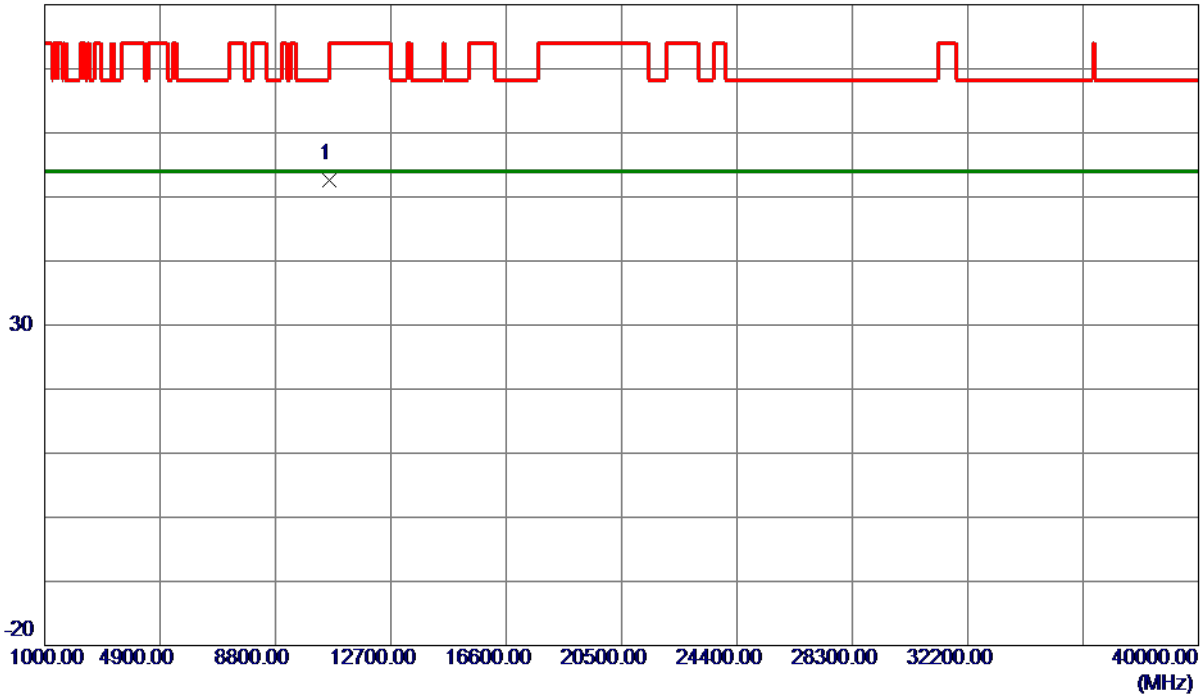

No.	Freq. MHz	Reading Level dBuV/m	Correct Factor dB	Measure ment dBuV/m	Limit dBuV/m	Margin dB	Detector	Comment
1 *	10619.8179	38.99	13.71	52.70	74.00	-21.30	Peak	

REMARKS:

- (1) Measurement Value = Reading Level + Correct Factor.
- (2) Margin Level = Measurement Value - Limit Value.

Orthogonal Axis	X
Test Mode	UNII-2A_TX AC (VHT40) Mode 5310 MHz

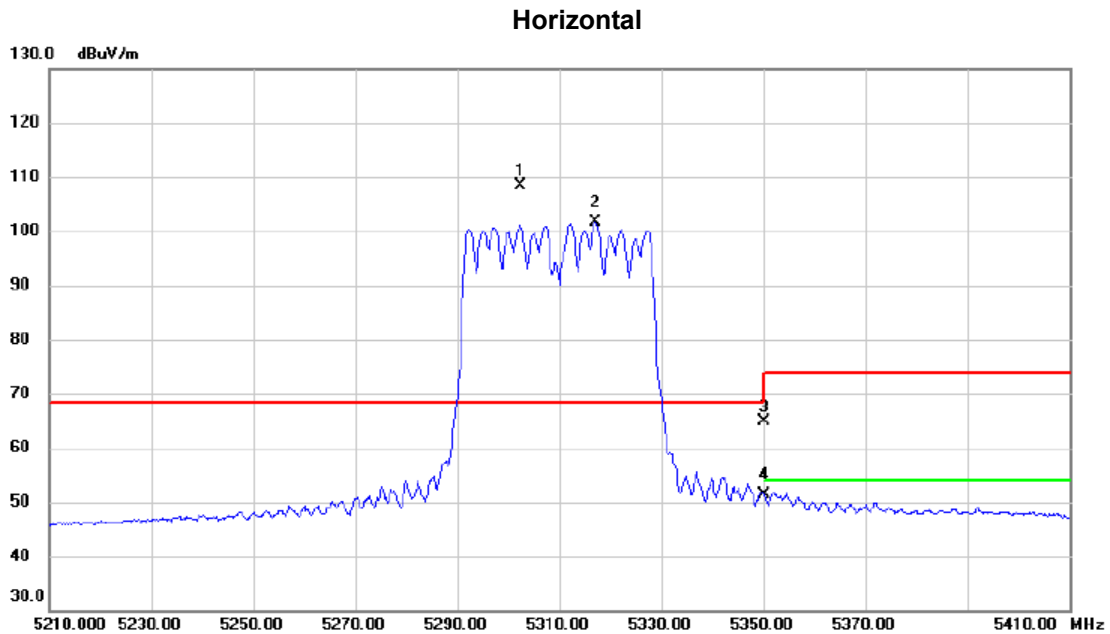

No.	Mk.	Freq. MHz	Reading Level dBuV	Correct Factor dB	Measure- ment dBuV/m	Limit dBuV/m	Margin dB	Detector	Comment
1	*	5302.400	91.94	16.51	108.45	68.30	40.15	peak	No Limit
2	X	5317.200	85.07	16.55	101.62	68.30	33.32	AVG	No Limit
3		5350.000	48.13	16.63	64.76	74.00	-9.24	peak	
4		5350.000	34.63	16.63	51.26	54.00	-2.74	AVG	

REMARKS:

- (1) Measurement Value = Reading Level + Correct Factor.
- (2) Margin Level = Measurement Value - Limit Value.

Orthogonal Axis	X
Test Mode	UNII-2A_TX AC (VHT40) Mode 5310 MHz

Horizontal

80 dBuV/m

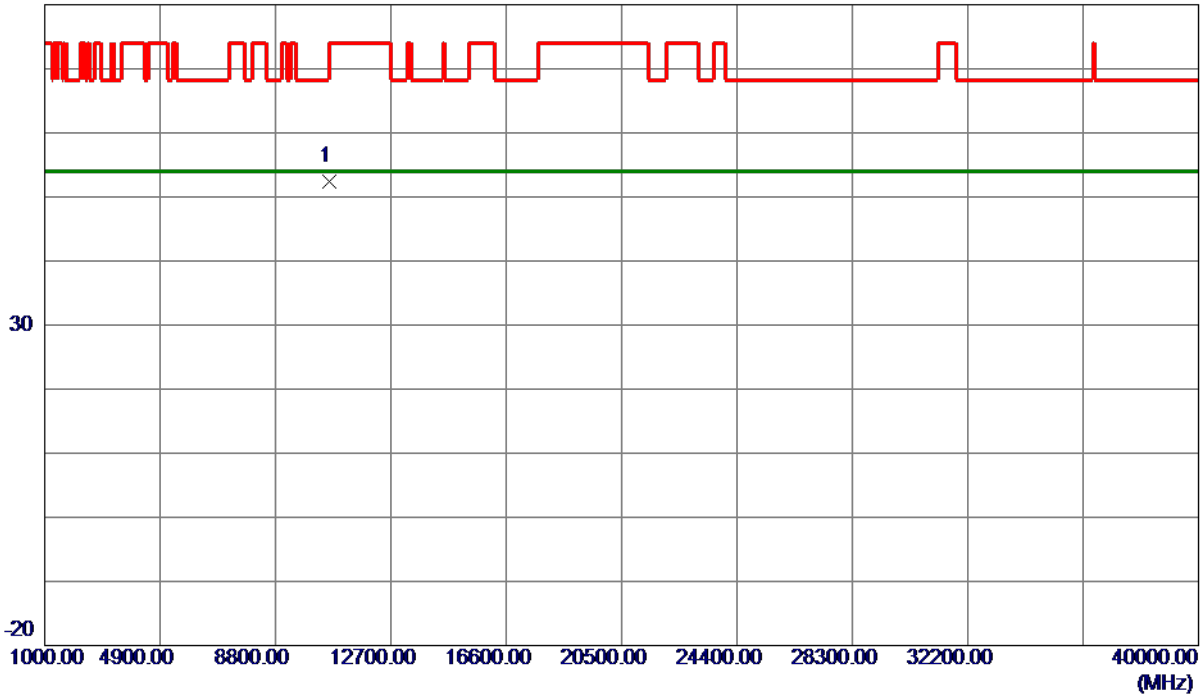

No.	Freq. MHz	Reading Level dBuV/m	Correct Factor dB	Measure ment dBuV/m	Limit dBuV/m	Margin dB	Detector	Comment
1 *	10620.3380	38.63	13.71	52.34	74.00	-21.66	Peak	

REMARKS:

- (1) Measurement Value = Reading Level + Correct Factor.
- (2) Margin Level = Measurement Value - Limit Value.

Orthogonal Axis	X
Test Mode	UNII-2A_TX AC (VHT80) Mode 5290 MHz

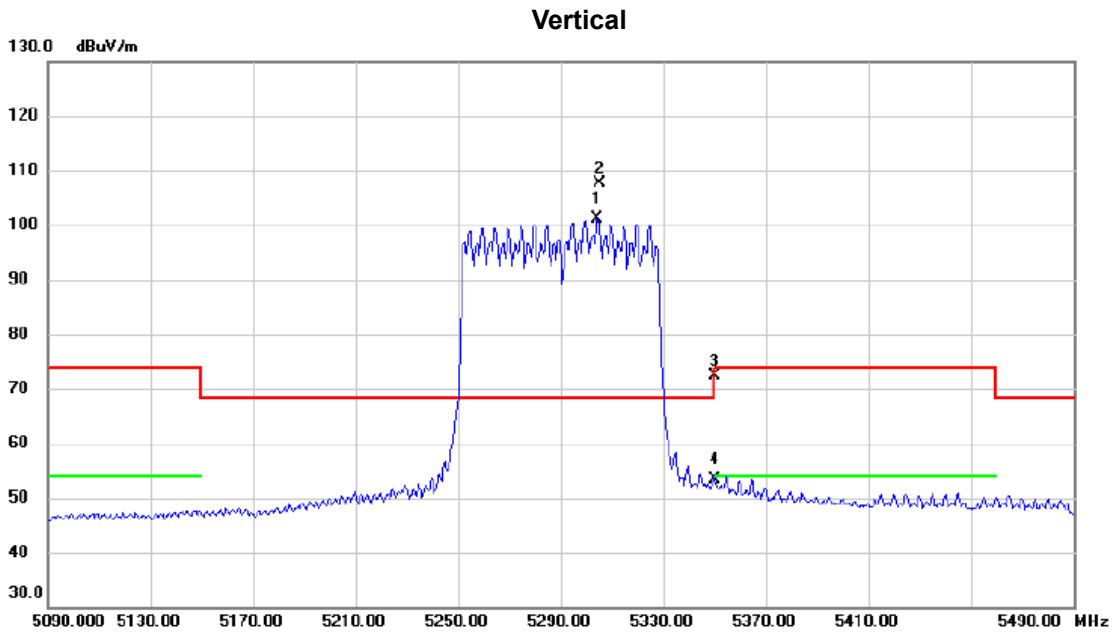

No.	Mk.	Freq. MHz	Reading Level dBuV	Correct Factor dB	Measure- ment dBuV/m	Limit dBuV/m	Margin dB	Detector	Comment
1	X	5304.400	84.66	16.52	101.18	68.30	32.88	AVG	No Limit
2	*	5305.200	91.23	16.52	107.75	68.30	39.45	peak	No Limit
3		5350.000	55.75	16.63	72.38	74.00	-1.62	peak	
4		5350.000	36.66	16.63	53.29	54.00	-0.71	AVG	

REMARKS:

- (1) Measurement Value = Reading Level + Correct Factor.
- (2) Margin Level = Measurement Value - Limit Value.

Orthogonal Axis	X
Test Mode	UNII-2A_TX AC (VHT80) Mode 5290 MHz

Vertical

80 dBuV/m

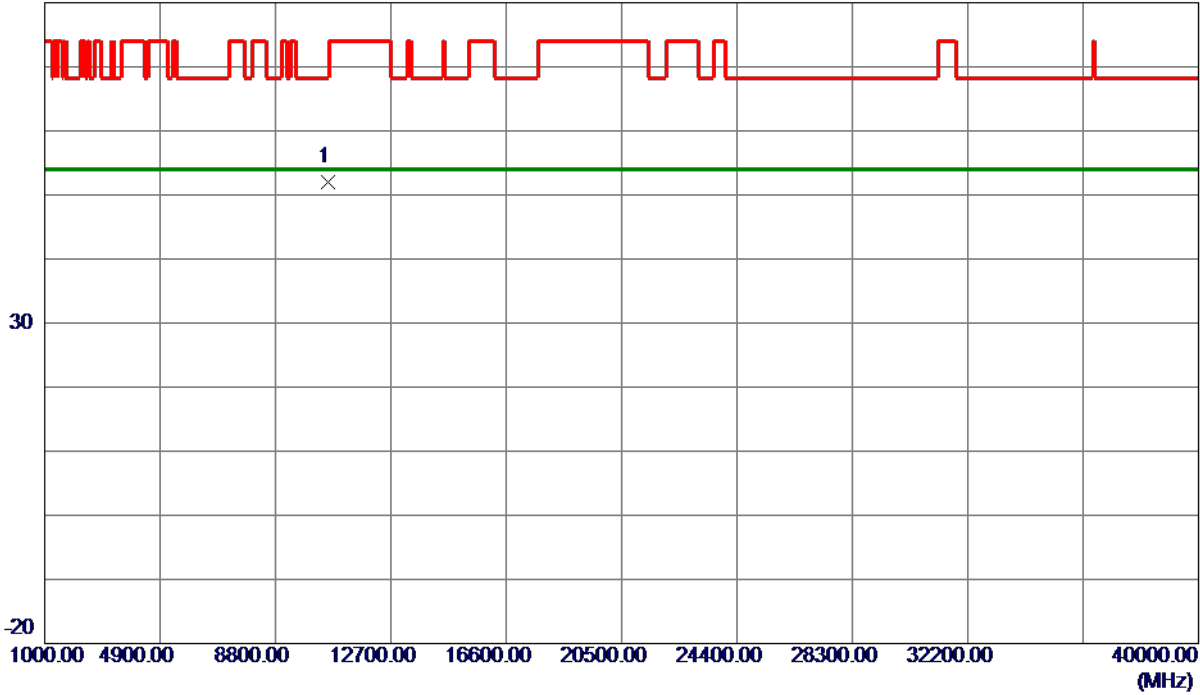

No.	Freq. MHz	Reading Level dBuV/m	Correct Factor dB	Measure ment dBuV/m	Limit dBuV/m	Margin dB	Detector	Comment
1 *	10580.9420	38.37	13.69	52.06	68.30	-16.24	Peak	

REMARKS:

- (1) Measurement Value = Reading Level + Correct Factor.
- (2) Margin Level = Measurement Value - Limit Value.

Orthogonal Axis	X
Test Mode	UNII-2A_TX AC (VHT80) Mode 5290 MHz

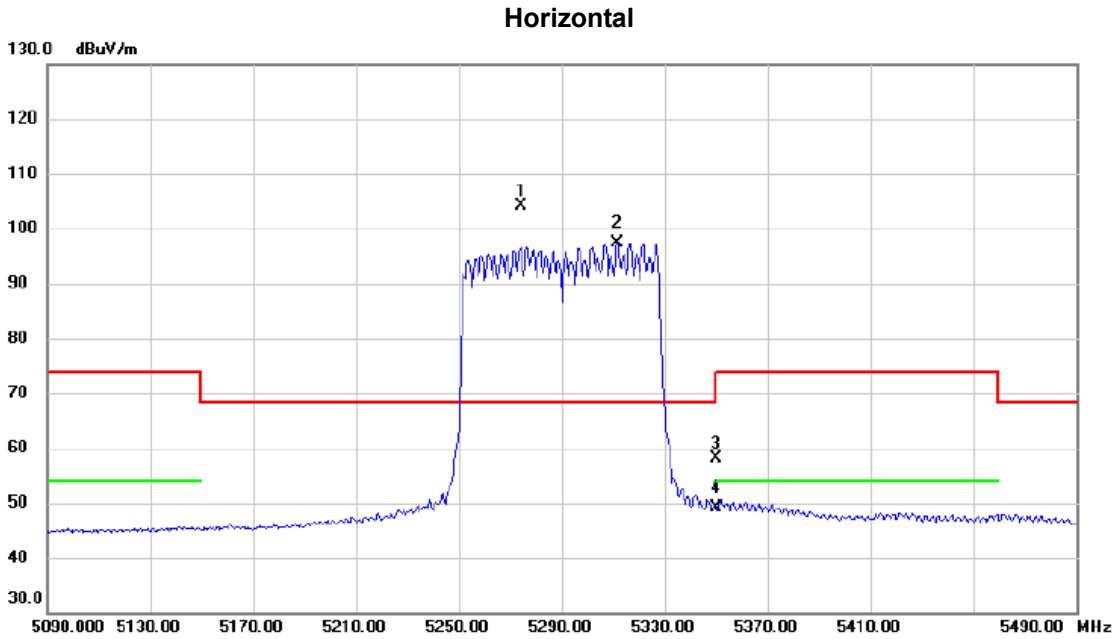

No.	Mk.	Freq. MHz	Reading Level dBuV	Correct Factor dB	Measure- ment dBuV/m	Limit dBuV/m	Margin dB	Detector	Comment
1	*	5274.000	87.66	16.45	104.11	68.30	35.81	peak	No Limit
2	X	5311.600	80.88	16.53	97.41	68.30	29.11	AVG	No Limit
3		5350.000	41.51	16.63	58.14	74.00	-15.86	peak	
4		5350.000	32.41	16.63	49.04	54.00	-4.96	AVG	

REMARKS:

- (1) Measurement Value = Reading Level + Correct Factor.
- (2) Margin Level = Measurement Value - Limit Value.

Orthogonal Axis	X
Test Mode	UNII-2A_TX AC (VHT80) Mode 5290 MHz

Horizontal

80 dBuV/m

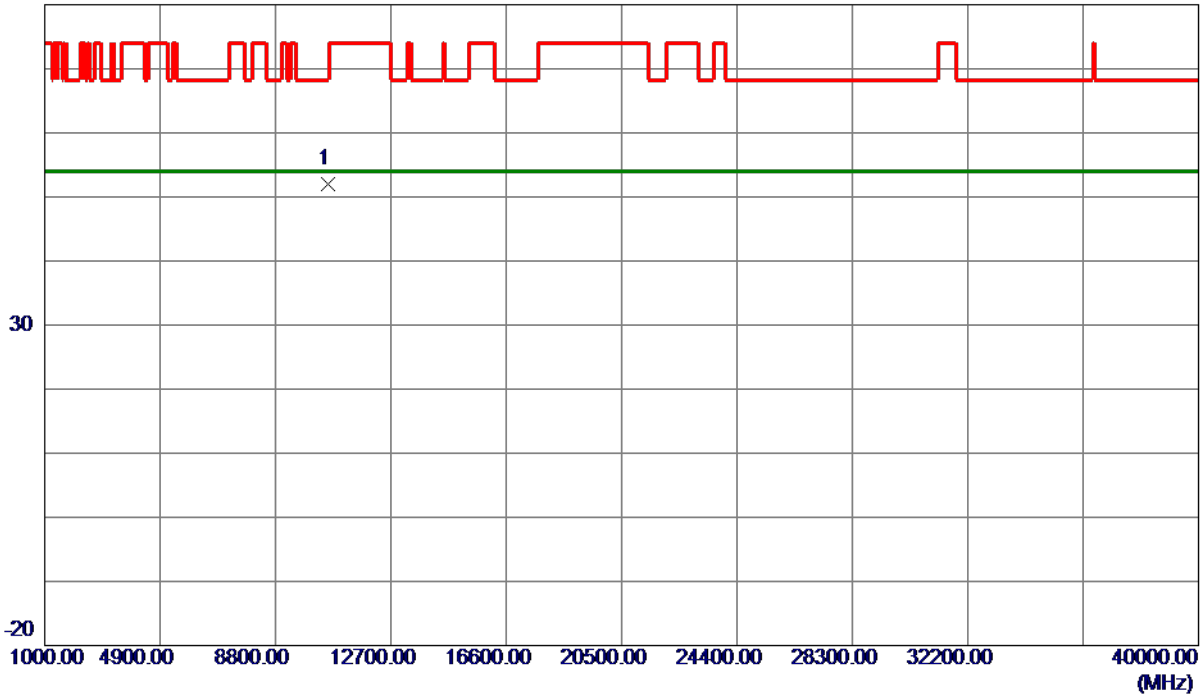

No.	Freq. MHz	Reading Level dBuV/m	Correct Factor dB	Measure ment dBuV/m	Limit dBuV/m	Margin dB	Detector	Comment
1 *	10579.5080	38.30	13.69	51.99	68.30	-16.31	Peak	

REMARKS:

- (1) Measurement Value = Reading Level + Correct Factor.
- (2) Margin Level = Measurement Value - Limit Value.

Orthogonal Axis	X
Test Mode	UNII-2C_TX AC (VHT20) Mode 5500 MHz

Vertical

130 dBuV/m

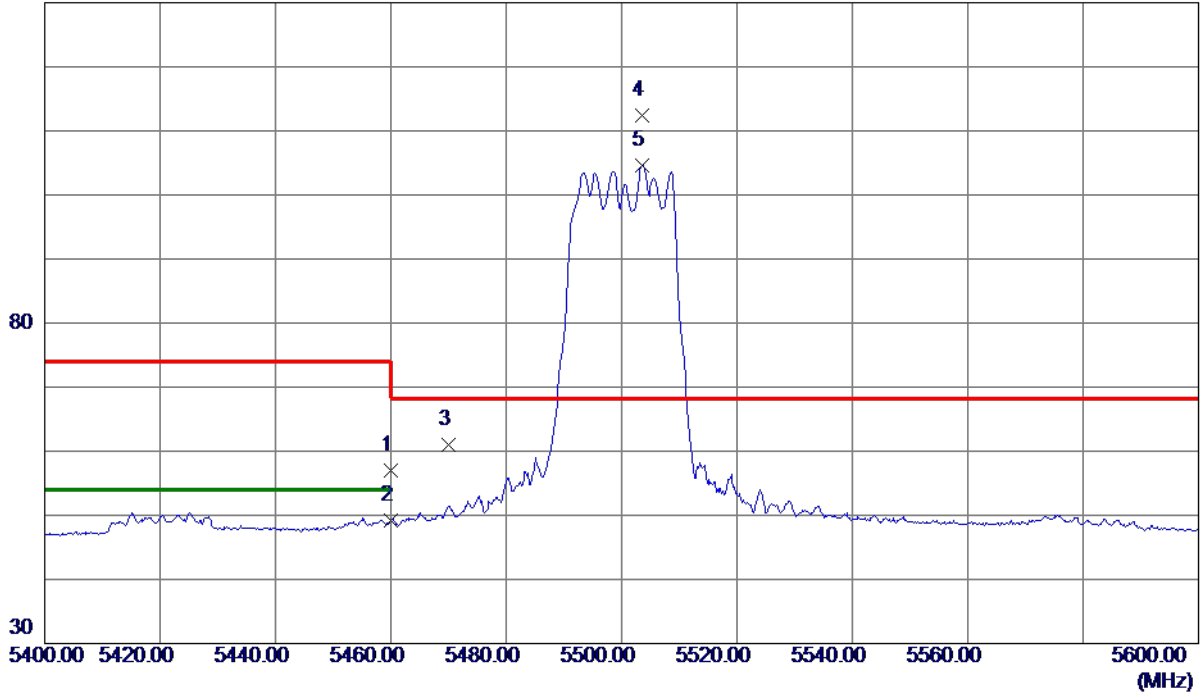

No.	Freq. MHz	Reading Level dBuV/m	Correct Factor dB	Measure ment dBuV/m	Limit dBuV/m	Margin dB	Detector	Comment
1	5460.0000	40.15	16.89	57.04	74.00	-16.96	Peak	
2	5460.0000	32.33	16.89	49.22	54.00	-4.78	AVG	
3	5470.0000	44.13	16.91	61.04	68.30	-7.26	Peak	
4 *	5503.6000	95.44	17.00	112.44	68.30	44.14	Peak	No Limit
5	5503.6000	87.61	17.00	104.61	999.00	-894.39	AVG	No Limit

REMARKS:

- (1) Measurement Value = Reading Level + Correct Factor.
- (2) Margin Level = Measurement Value - Limit Value.

Orthogonal Axis	X
Test Mode	UNII-2C_TX AC (VHT20) Mode 5500 MHz

Vertical

80 dBuV/m

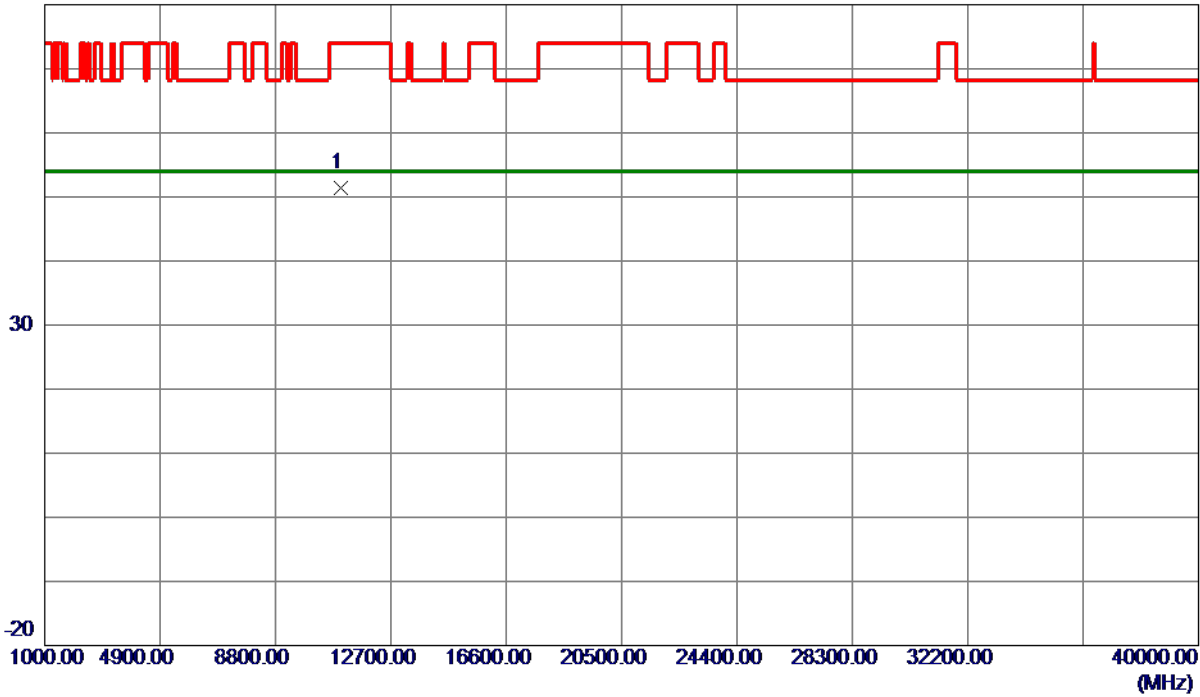

No.	Freq. MHz	Reading Level dBuV/m	Correct Factor dB	Measure ment dBuV/m	Limit dBuV/m	Margin dB	Detector	Comment
1 *	11001.5050	37.41	13.92	51.33	74.00	-22.67	Peak	

REMARKS:

- (1) Measurement Value = Reading Level + Correct Factor.
- (2) Margin Level = Measurement Value - Limit Value.

Orthogonal Axis	X
Test Mode	UNII-2C_TX AC (VHT20) Mode 5500 MHz

Horizontal

130 dBuV/m

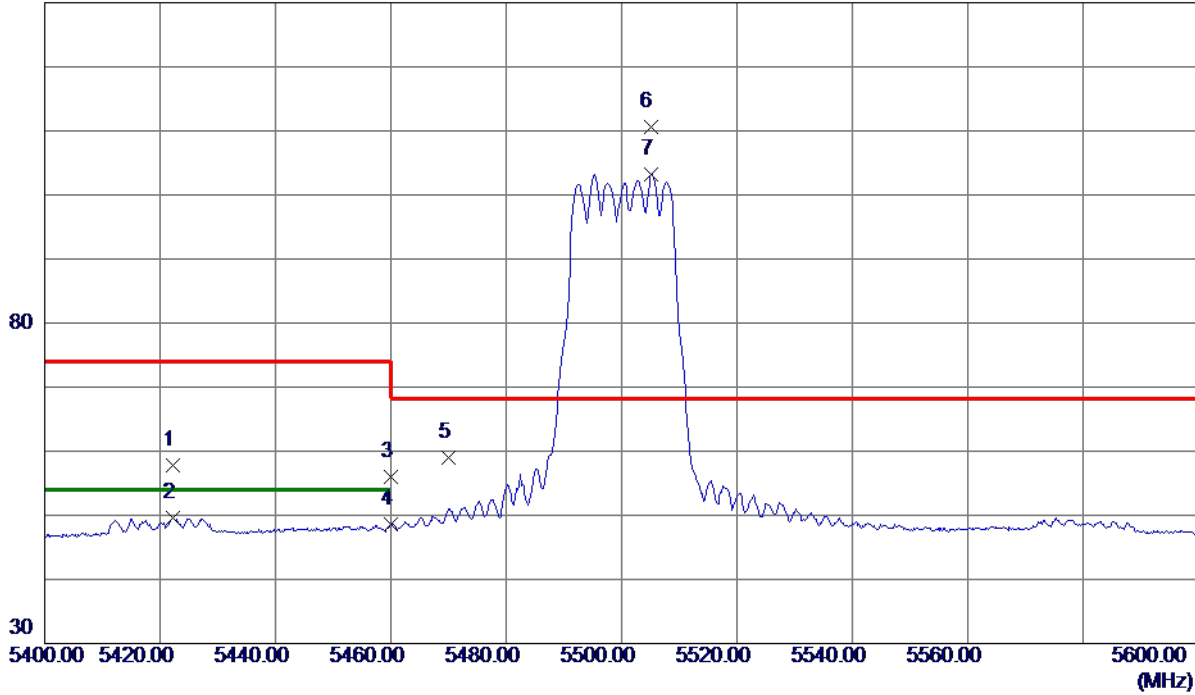

No.	Freq. MHz	Reading Level dBuV/m	Correct Factor dB	Measure ment dBuV/m	Limit dBuV/m	Margin dB	Detector	Comment
1	5422.2000	41.05	16.80	57.85	74.00	-16.15	Peak	
2	5422.2000	32.83	16.80	49.63	54.00	-4.37	AVG	
3	5460.0000	39.09	16.89	55.98	74.00	-18.02	Peak	
4	5460.0000	31.75	16.89	48.64	54.00	-5.36	AVG	
5	5470.0000	42.00	16.91	58.91	68.30	-9.39	Peak	
6 *	5505.0000	93.68	17.00	110.68	68.30	42.38	Peak	No Limit
7	5505.2000	86.28	17.00	103.28	999.00	-895.72	AVG	No Limit

REMARKS:

- (1) Measurement Value = Reading Level + Correct Factor.
- (2) Margin Level = Measurement Value - Limit Value.

Orthogonal Axis	X
Test Mode	UNII-2C_TX AC (VHT20) Mode 5500 MHz

Horizontal

80 dBuV/m

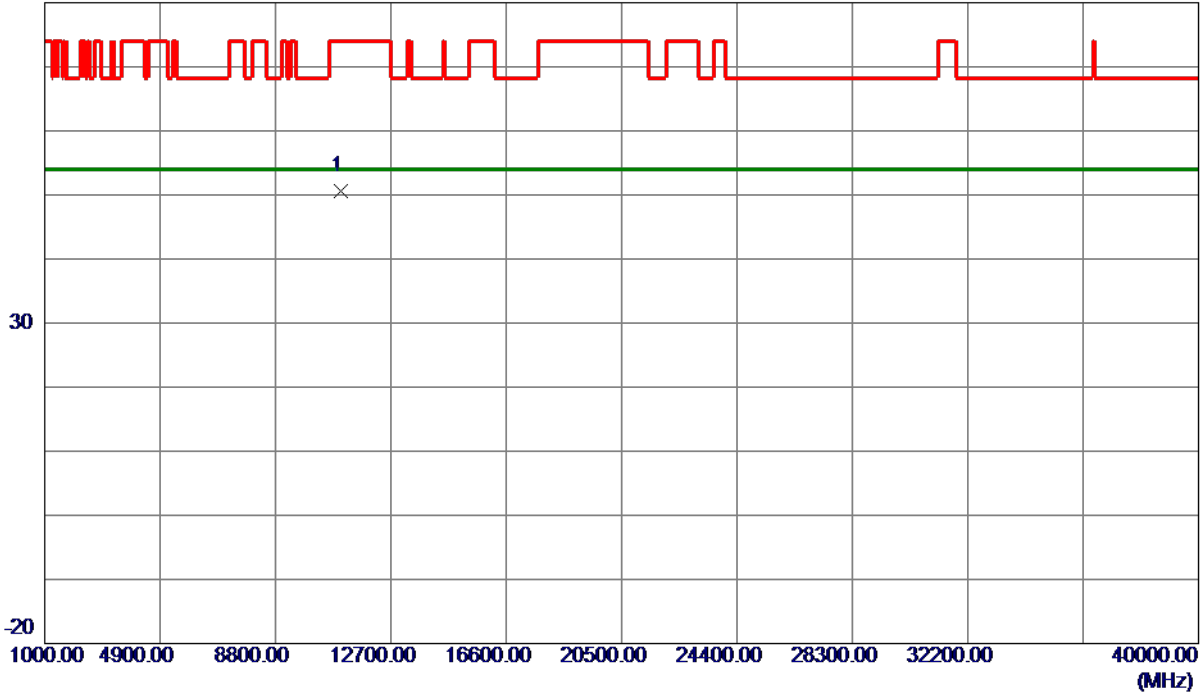

No.	Freq. MHz	Reading Level dBuV/m	Correct Factor dB	Measure ment dBuV/m	Limit dBuV/m	Margin dB	Detector	Comment
1 *	11001.5800	36.76	13.92	50.68	74.00	-23.32	Peak	

REMARKS:

- (1) Measurement Value = Reading Level + Correct Factor.
- (2) Margin Level = Measurement Value - Limit Value.

Orthogonal Axis	X
Test Mode	UNII-2C_TX AC (VHT20) Mode 5580 MHz

Vertical

130 dBuV/m

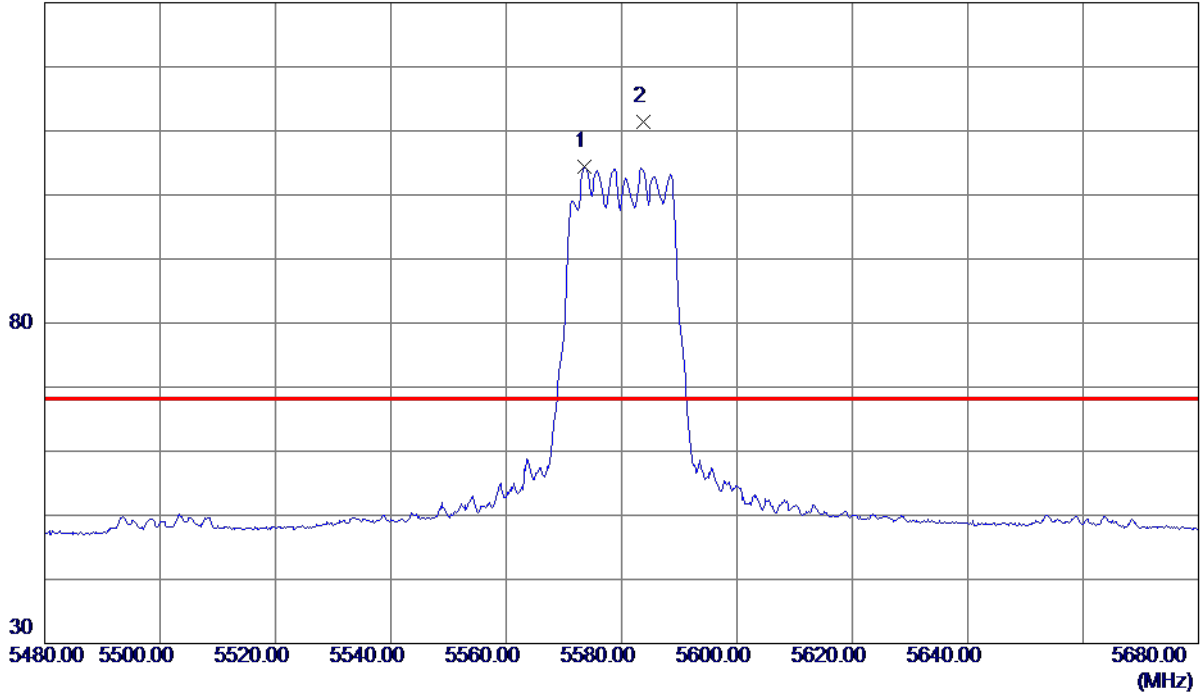

No.	Freq. MHz	Reading Level dBuV/m	Correct Factor dB	Measure ment dBuV/m	Limit dBuV/m	Margin dB	Detector	Comment
1	5573.6000	87.12	17.20	104.32	999.00	-894.68	AVG	No Limit
2 *	5583.8000	94.12	17.23	111.35	68.30	43.05	Peak	No Limit

REMARKS:

- (1) Measurement Value = Reading Level + Correct Factor.
- (2) Margin Level = Measurement Value - Limit Value.

Orthogonal Axis	X
Test Mode	UNII-2C_TX AC (VHT20) Mode 5580 MHz

Vertical

80 dBuV/m



No.	Freq. MHz	Reading Level dBuV/m	Correct Factor dB	Measure ment dBuV/m	Limit dBuV/m	Margin dB	Detector	Comment
1 *	11161.0100	37.06	14.13	51.19	74.00	-22.81	Peak	

REMARKS:

- (1) Measurement Value = Reading Level + Correct Factor.
- (2) Margin Level = Measurement Value - Limit Value.

Orthogonal Axis	X
Test Mode	UNII-2C_TX AC (VHT20) Mode 5580 MHz

Horizontal

130 dBuV/m

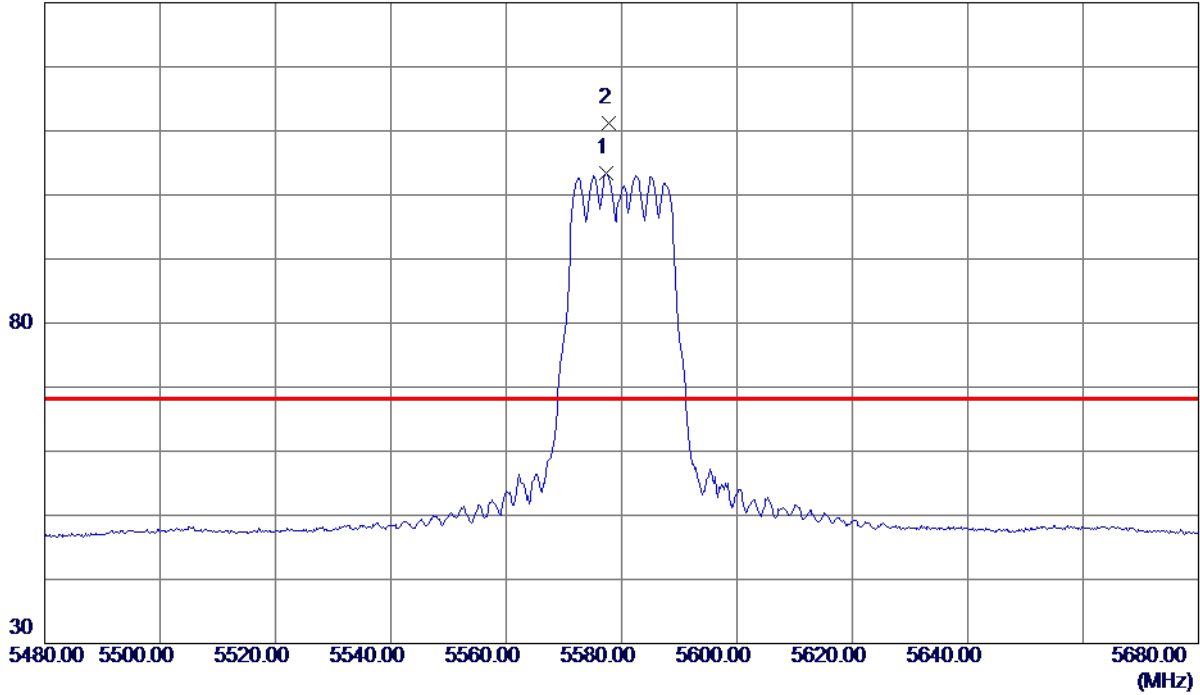

No.	Freq. MHz	Reading Level dBuV/m	Correct Factor dB	Measure ment dBuV/m	Limit dBuV/m	Margin dB	Detector	Comment
1	5577.4000	86.15	17.21	103.36	999.00	-895.64	AVG	No Limit
2 *	5577.8000	93.89	17.22	111.11	68.30	42.81	Peak	No Limit

REMARKS:

- (1) Measurement Value = Reading Level + Correct Factor.
- (2) Margin Level = Measurement Value - Limit Value.

Orthogonal Axis	X
Test Mode	UNII-2C_TX AC (VHT20) Mode 5580 MHz

Horizontal

80 dBuV/m

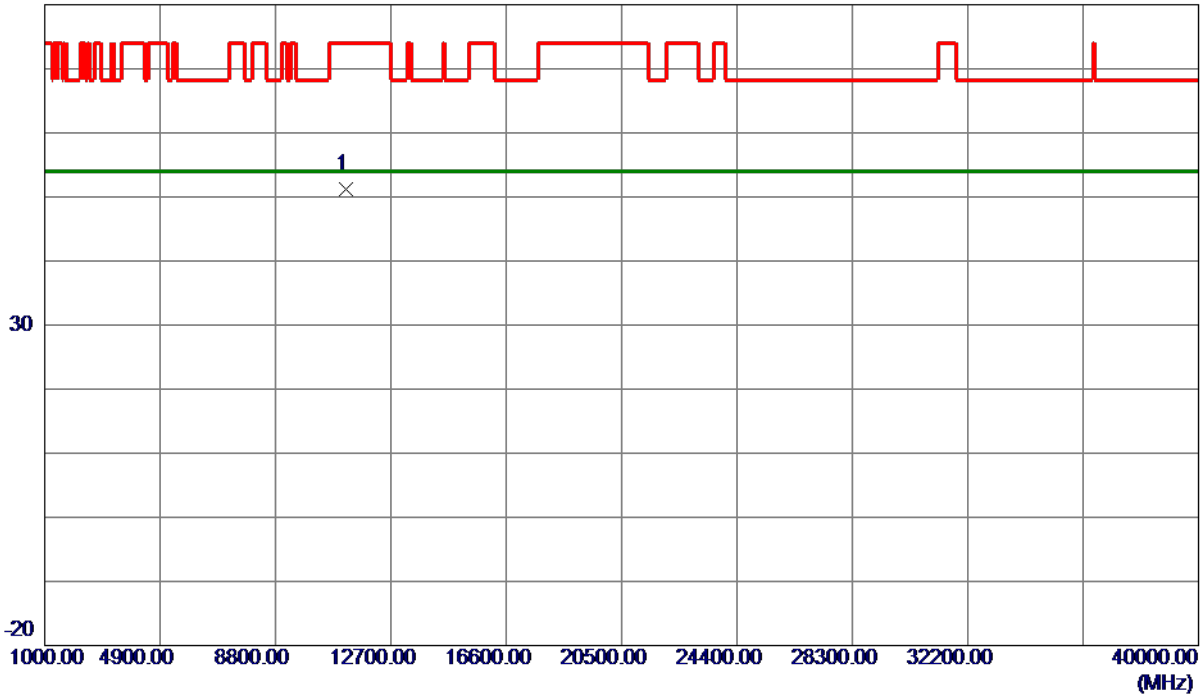

No.	Freq. MHz	Reading Level dBuV/m	Correct Factor dB	Measure ment dBuV/m	Limit dBuV/m	Margin dB	Detector	Comment
1 *	11162.0150	37.09	14.13	51.22	74.00	-22.78	Peak	

REMARKS:

- (1) Measurement Value = Reading Level + Correct Factor.
- (2) Margin Level = Measurement Value - Limit Value.

Orthogonal Axis	X
Test Mode	UNII-2C_TX AC (VHT20) Mode 5700 MHz

Vertical

130 dBuV/m

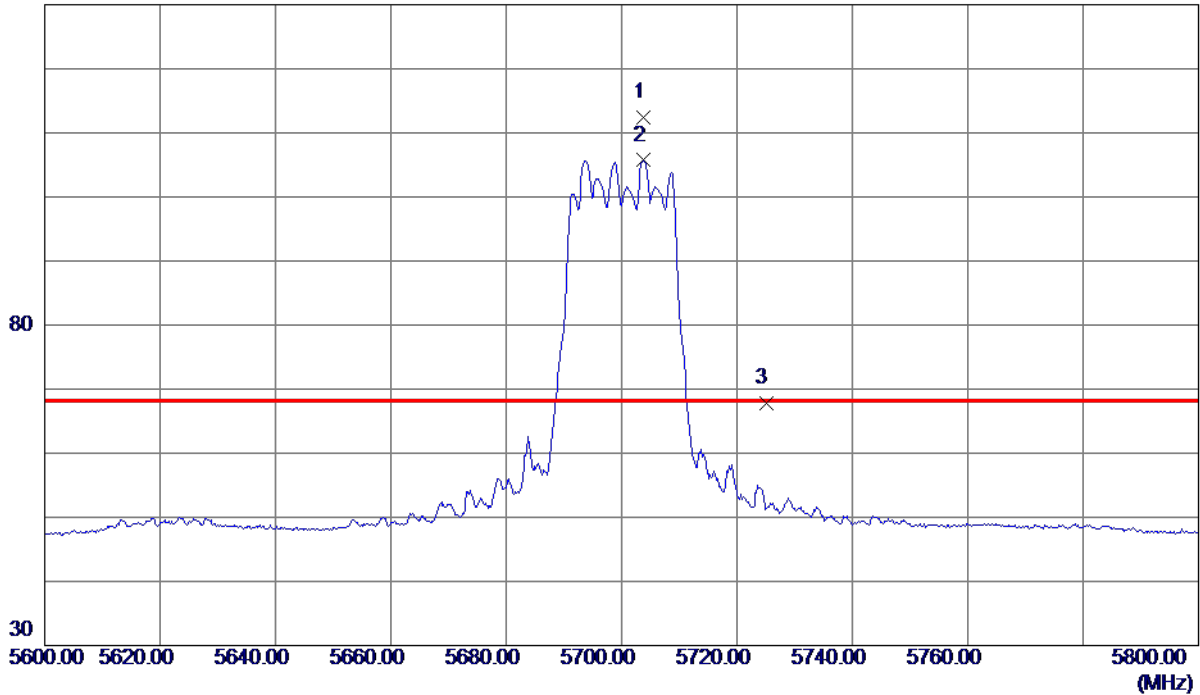

No.	Freq. MHz	Reading Level dBuV/m	Correct Factor dB	Measure ment dBuV/m	Limit dBuV/m	Margin dB	Detector	Comment
1 *	5703.8000	94.86	17.59	112.45	68.30	44.15	Peak	No Limit
2	5703.8000	88.11	17.59	105.70	999.00	-893.30	AVG	No Limit
3	5725.0000	50.12	17.65	67.77	68.30	-0.53	Peak	

REMARKS:

- (1) Measurement Value = Reading Level + Correct Factor.
- (2) Margin Level = Measurement Value - Limit Value.

Orthogonal Axis	X
Test Mode	UNII-2C_TX AC (VHT20) Mode 5700 MHz

Vertical

80 dBuV/m

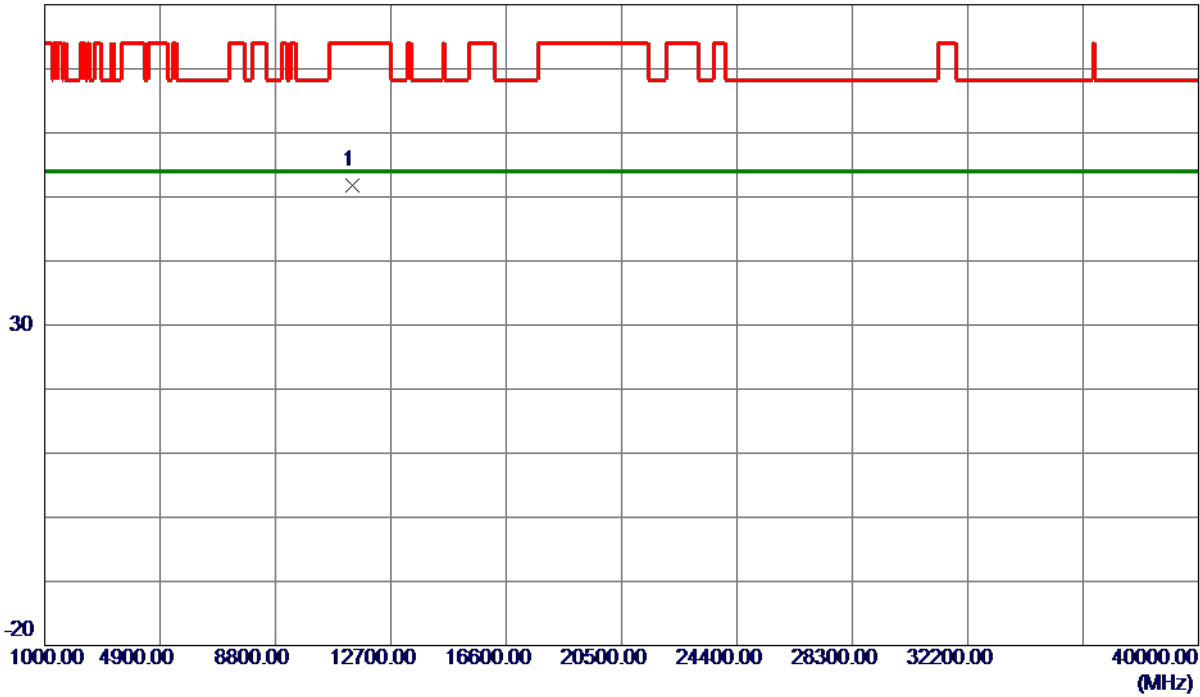

No.	Freq. MHz	Reading Level dBuV/m	Correct Factor dB	Measure ment dBuV/m	Limit dBuV/m	Margin dB	Detector	Comment
1 *	11397.8000	37.30	14.43	51.73	74.00	-22.27	Peak	

REMARKS:

- (1) Measurement Value = Reading Level + Correct Factor.
- (2) Margin Level = Measurement Value - Limit Value.

Orthogonal Axis	X
Test Mode	UNII-2C_TX AC (VHT20) Mode 5700 MHz

Horizontal

130 dBuV/m

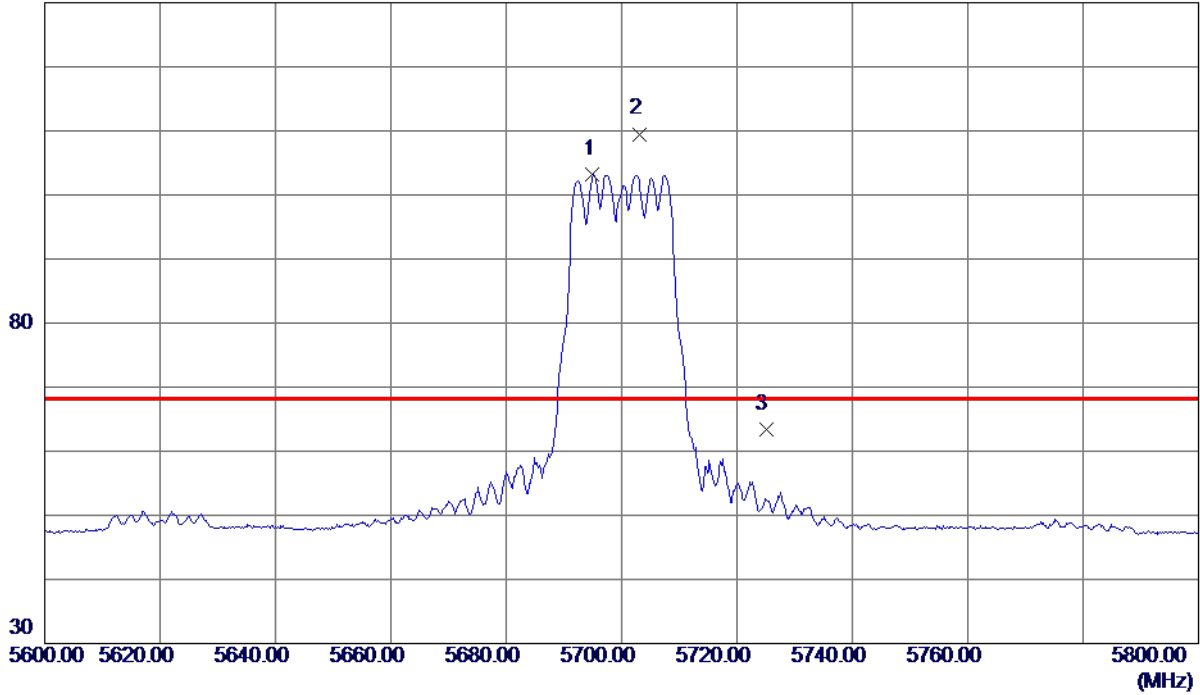

No.	Freq. MHz	Reading Level dBuV/m	Correct Factor dB	Measure ment dBuV/m	Limit dBuV/m	Margin dB	Detector	Comment
1	5695.0000	85.58	17.56	103.14	999.00	-895.86	AVG	No Limit
2 *	5703.2000	91.91	17.59	109.50	68.30	41.20	Peak	No Limit
3	5725.0000	45.74	17.65	63.39	68.30	-4.91	Peak	

REMARKS:

- (1) Measurement Value = Reading Level + Correct Factor.
- (2) Margin Level = Measurement Value - Limit Value.

Orthogonal Axis	X
Test Mode	UNII-2C_TX AC (VHT20) Mode 5700 MHz

Horizontal

80 dBuV/m



No.	Freq. MHz	Reading Level dBuV/m	Correct Factor dB	Measure ment dBuV/m	Limit dBuV/m	Margin dB	Detector	Comment
1 *	11400.0100	37.47	14.44	51.91	74.00	-22.09	Peak	

REMARKS:

- (1) Measurement Value = Reading Level + Correct Factor.
- (2) Margin Level = Measurement Value - Limit Value.

Orthogonal Axis	X
Test Mode	UNII-2C_TX AC (VHT40) Mode 5510 MHz

Vertical

130 dBuV/m

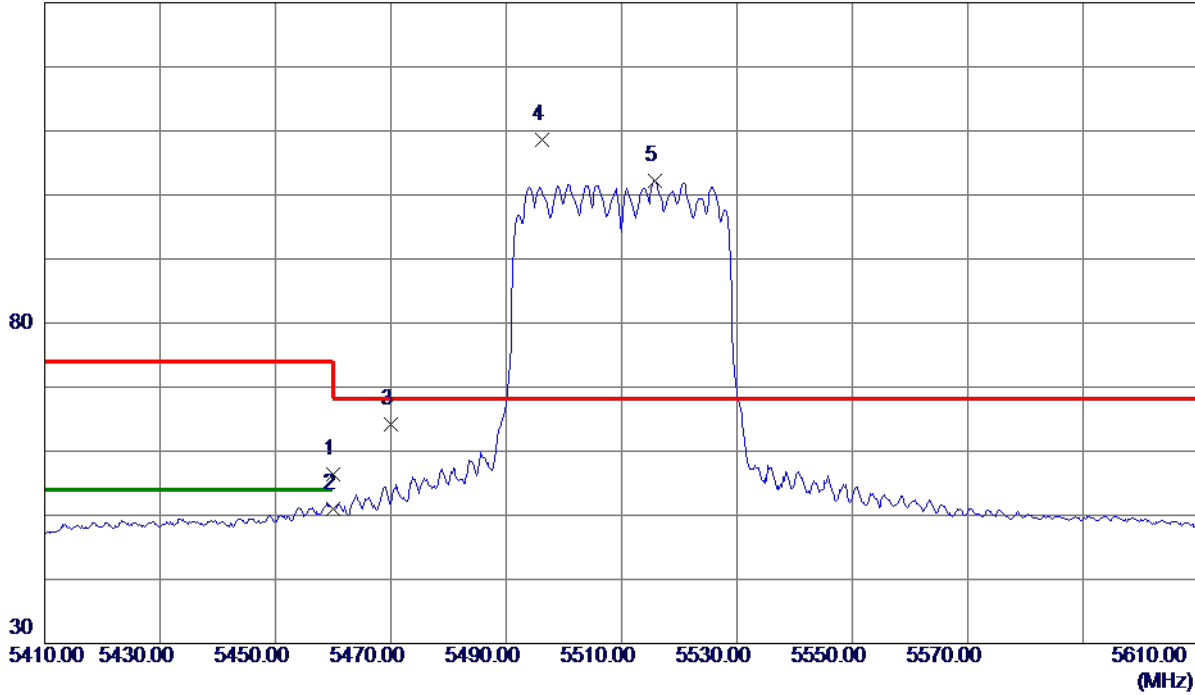

No.	Freq. MHz	Reading Level dBuV/m	Correct Factor dB	Measure ment dBuV/m	Limit dBuV/m	Margin dB	Detector	Comment
1	5460.0000	39.55	16.89	56.44	74.00	-17.56	Peak	
2	5460.0000	34.11	16.89	51.00	54.00	-3.00	AVG	
3	5470.0000	47.21	16.91	64.12	68.30	-4.18	Peak	
4 *	5496.2000	91.62	16.98	108.60	68.30	40.30	Peak	No Limit
5	5515.8000	85.20	17.03	102.23	999.00	-896.77	AVG	No Limit

REMARKS:

- (1) Measurement Value = Reading Level + Correct Factor.
- (2) Margin Level = Measurement Value - Limit Value.

Orthogonal Axis	X
Test Mode	UNII-2C_TX AC (VHT40) Mode 5510 MHz

Vertical

80 dBuV/m

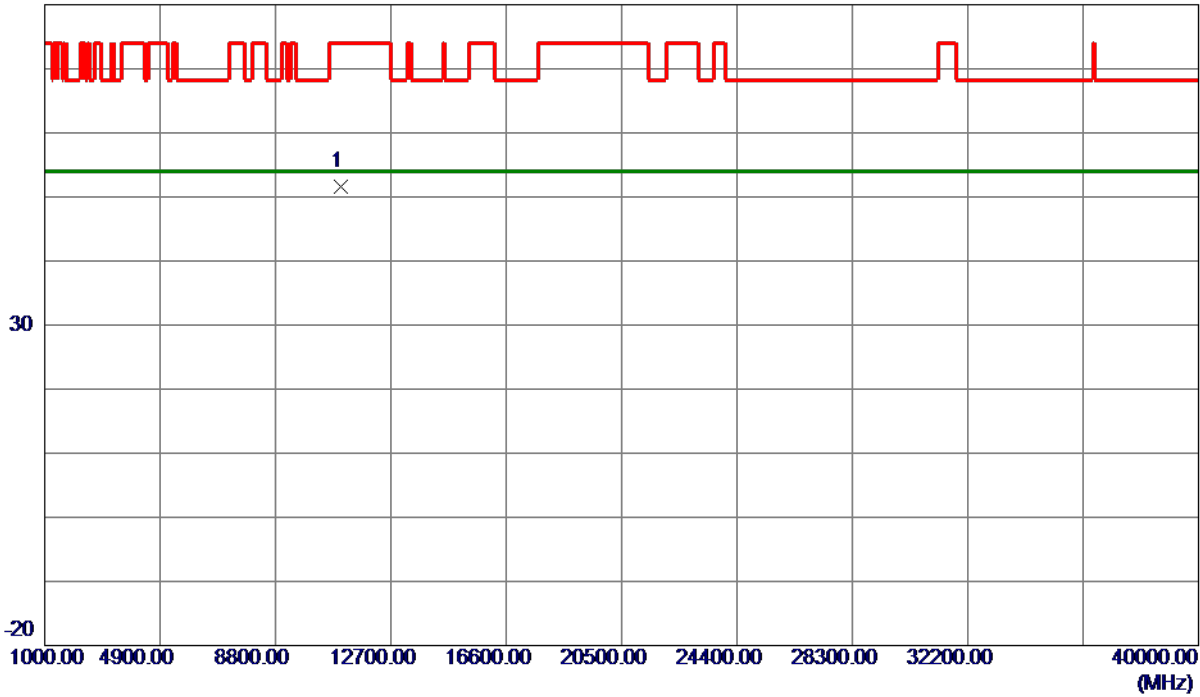

No.	Freq. MHz	Reading Level dBuV/m	Correct Factor dB	Measure ment dBuV/m	Limit dBuV/m	Margin dB	Detector	Comment
1 *	11020.7400	37.71	13.95	51.66	74.00	-22.34	Peak	

REMARKS:

- (1) Measurement Value = Reading Level + Correct Factor.
- (2) Margin Level = Measurement Value - Limit Value.

Orthogonal Axis	X
Test Mode	UNII-2C_TX AC (VHT40) Mode 5510 MHz

Horizontal

130 dBuV/m

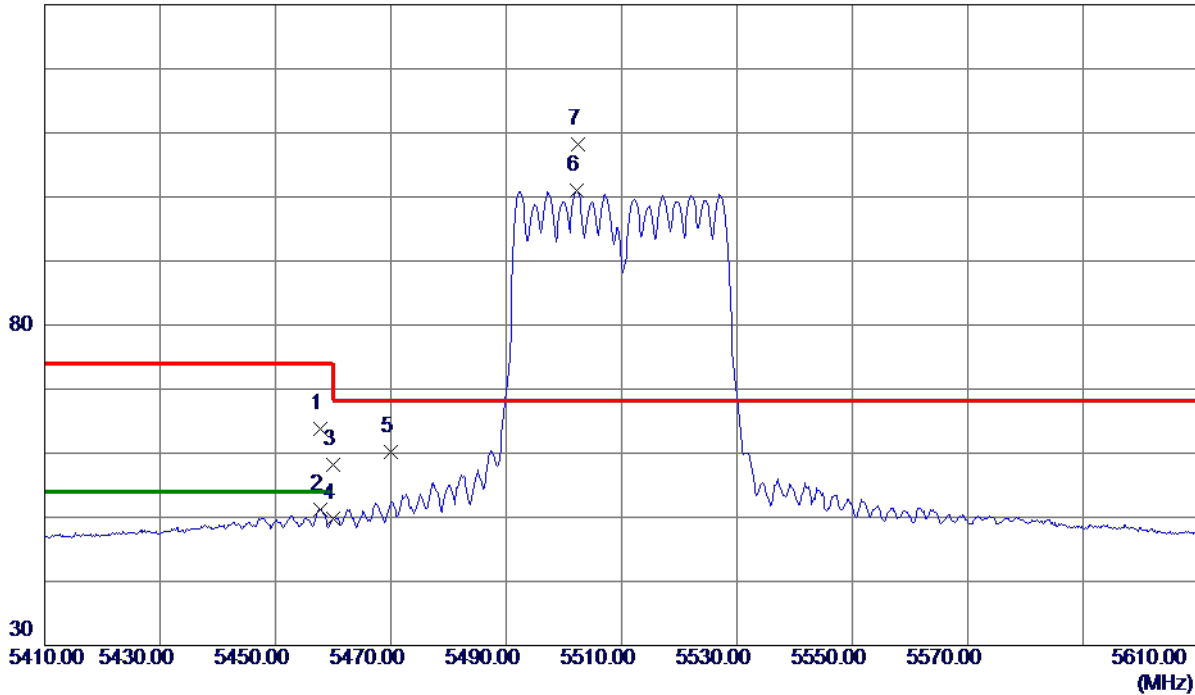

No.	Freq. MHz	Reading Level dBuV/m	Correct Factor dB	Measure ment dBuV/m	Limit dBuV/m	Margin dB	Detector	Comment
1	5457.8000	47.01	16.88	63.89	74.00	-10.11	Peak	
2	5457.8000	34.29	16.88	51.17	54.00	-2.83	AVG	
3	5460.0000	41.26	16.89	58.15	74.00	-15.85	Peak	
4	5460.0000	32.97	16.89	49.86	54.00	-4.14	AVG	
5	5470.0000	43.35	16.91	60.26	68.30	-8.04	Peak	
6	5502.2000	84.07	16.99	101.06	999.00	-897.94	AVG	No Limit
7 *	5502.4000	91.21	16.99	108.20	68.30	39.90	Peak	No Limit

REMARKS:

- (1) Measurement Value = Reading Level + Correct Factor.
- (2) Margin Level = Measurement Value - Limit Value.

Orthogonal Axis	X
Test Mode	UNII-2C_TX AC (VHT40) Mode 5510 MHz

Horizontal

80 dBuV/m

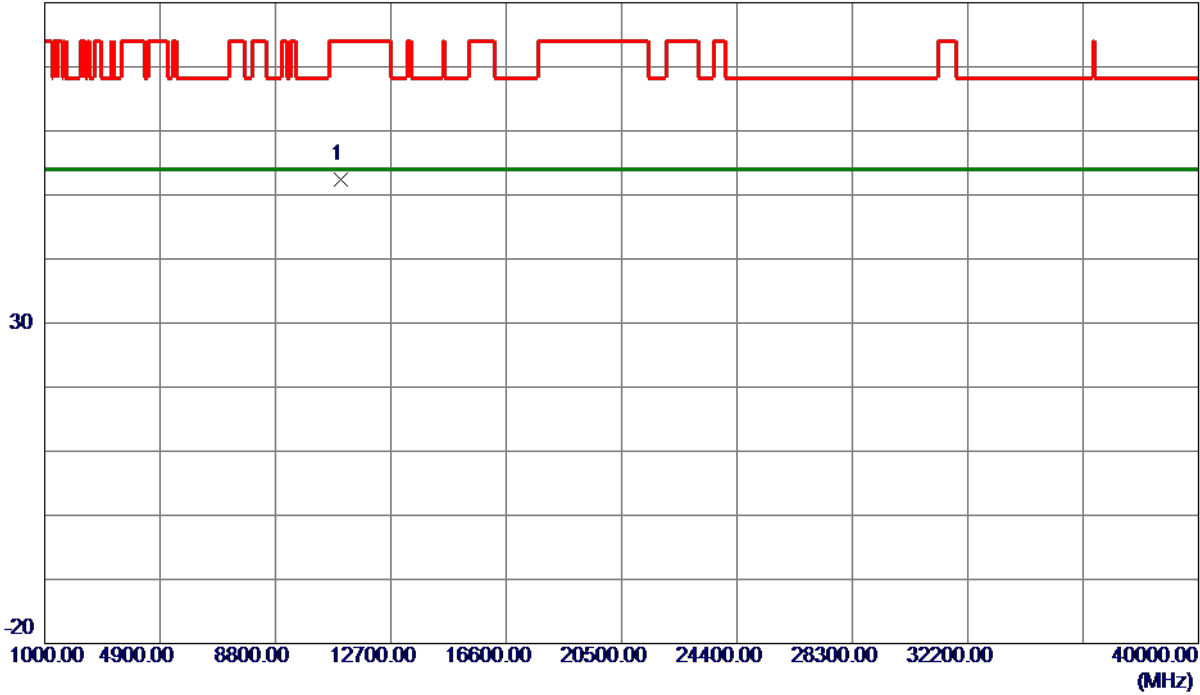

No.	Freq. MHz	Reading Level dBuV/m	Correct Factor dB	Measure ment dBuV/m	Limit dBuV/m	Margin dB	Detector	Comment
1 *	11020.3400	38.38	13.95	52.33	74.00	-21.67	Peak	

REMARKS:

- (1) Measurement Value = Reading Level + Correct Factor.
- (2) Margin Level = Measurement Value - Limit Value.

Orthogonal Axis	X
Test Mode	UNII-2C_TX AC (VHT40) Mode 5550 MHz

Vertical

130 dBuV/m

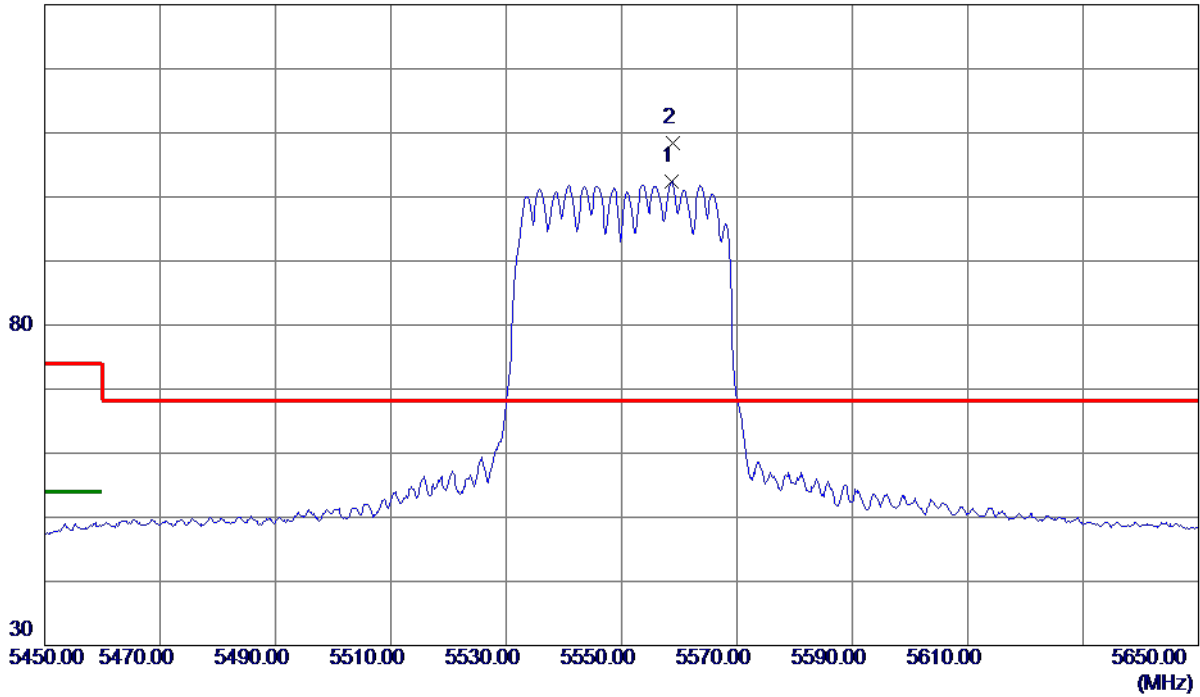

No.	Freq. MHz	Reading Level dBuV/m	Correct Factor dB	Measure ment dBuV/m	Limit dBuV/m	Margin dB	Detector	Comment
1	5558.6000	85.16	17.16	102.32	999.00	-896.68	AVG	No Limit
2 *	5558.8000	91.24	17.16	108.40	68.30	40.10	Peak	No Limit

REMARKS:

- (1) Measurement Value = Reading Level + Correct Factor.
- (2) Margin Level = Measurement Value - Limit Value.

Orthogonal Axis	X
Test Mode	UNII-2C_TX AC (VHT40) Mode 5550 MHz

Vertical

80 dBuV/m

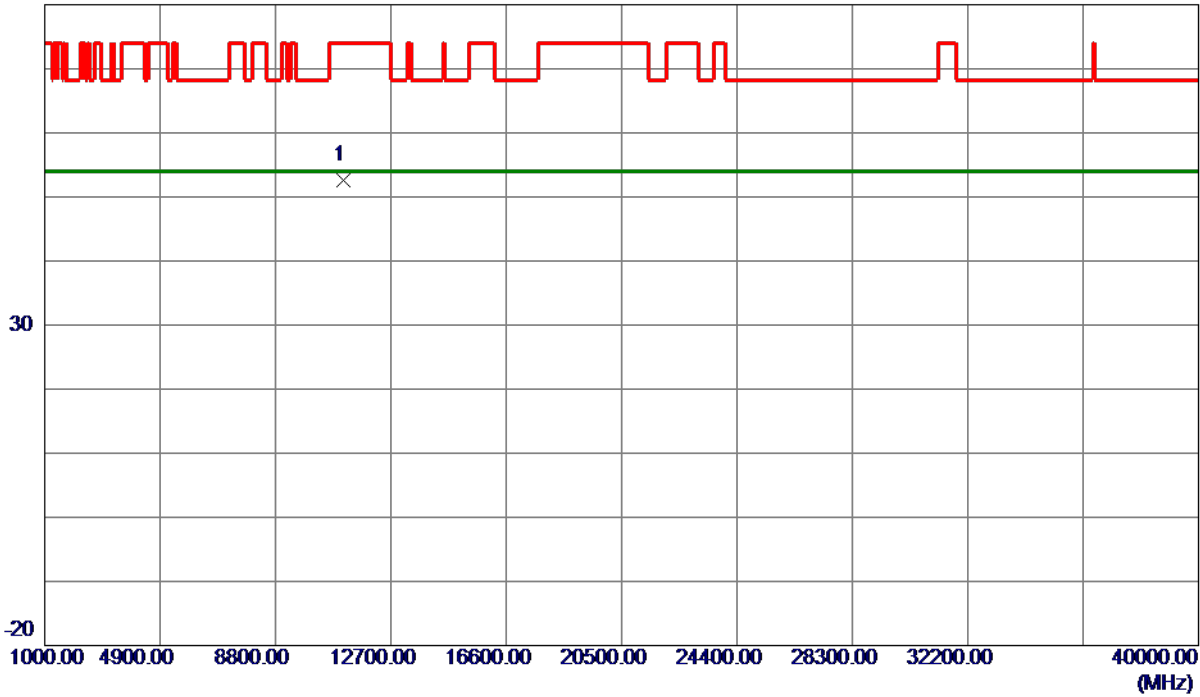

No.	Freq. MHz	Reading Level dBuV/m	Correct Factor dB	Measure ment dBuV/m	Limit dBuV/m	Margin dB	Detector	Comment
1 *	11099.3400	38.58	14.05	52.63	74.00	-21.37	Peak	

REMARKS:

- (1) Measurement Value = Reading Level + Correct Factor.
- (2) Margin Level = Measurement Value - Limit Value.

Orthogonal Axis	X
Test Mode	UNII-2C_TX AC (VHT40) Mode 5550 MHz

Horizontal

130 dBuV/m

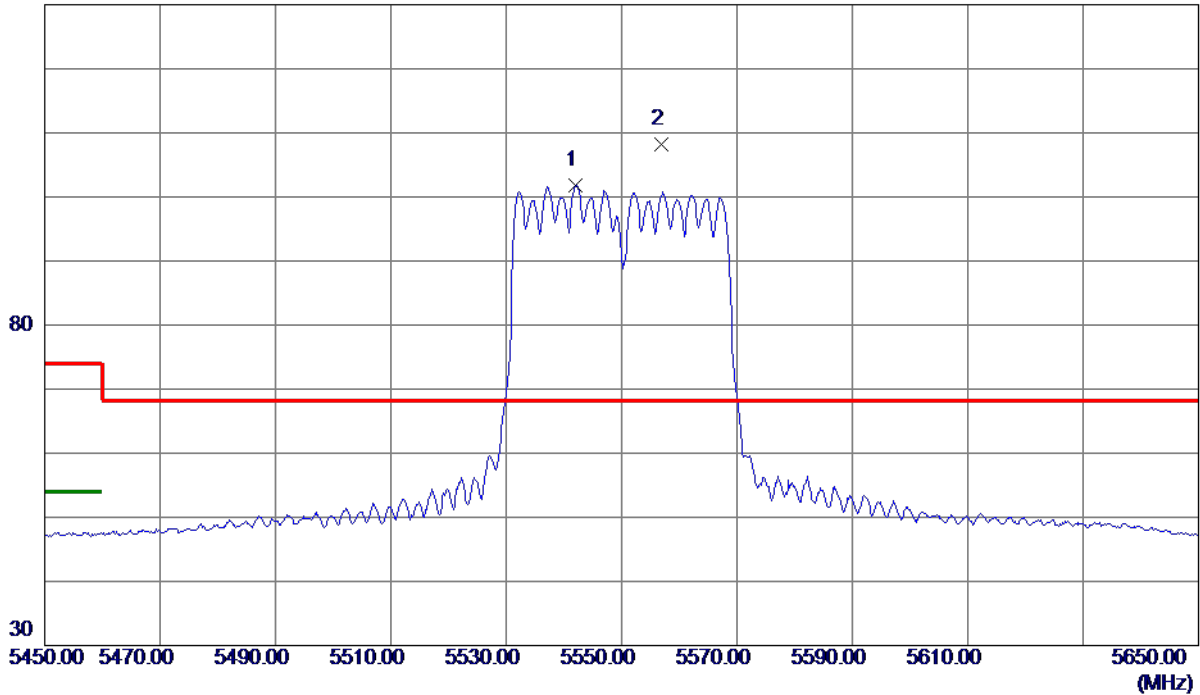

No.	Freq. MHz	Reading Level dBuV/m	Correct Factor dB	Measure ment dBuV/m	Limit dBuV/m	Margin dB	Detector	Comment
1	5542.0000	84.63	17.11	101.74	999.00	-897.26	AVG	No Limit
2 *	5556.8000	91.12	17.15	108.27	68.30	39.97	Peak	No Limit

REMARKS:

- (1) Measurement Value = Reading Level + Correct Factor.
- (2) Margin Level = Measurement Value - Limit Value.

Orthogonal Axis	X
Test Mode	UNII-2C_TX AC (VHT40) Mode 5550 MHz

Horizontal

80 dBuV/m

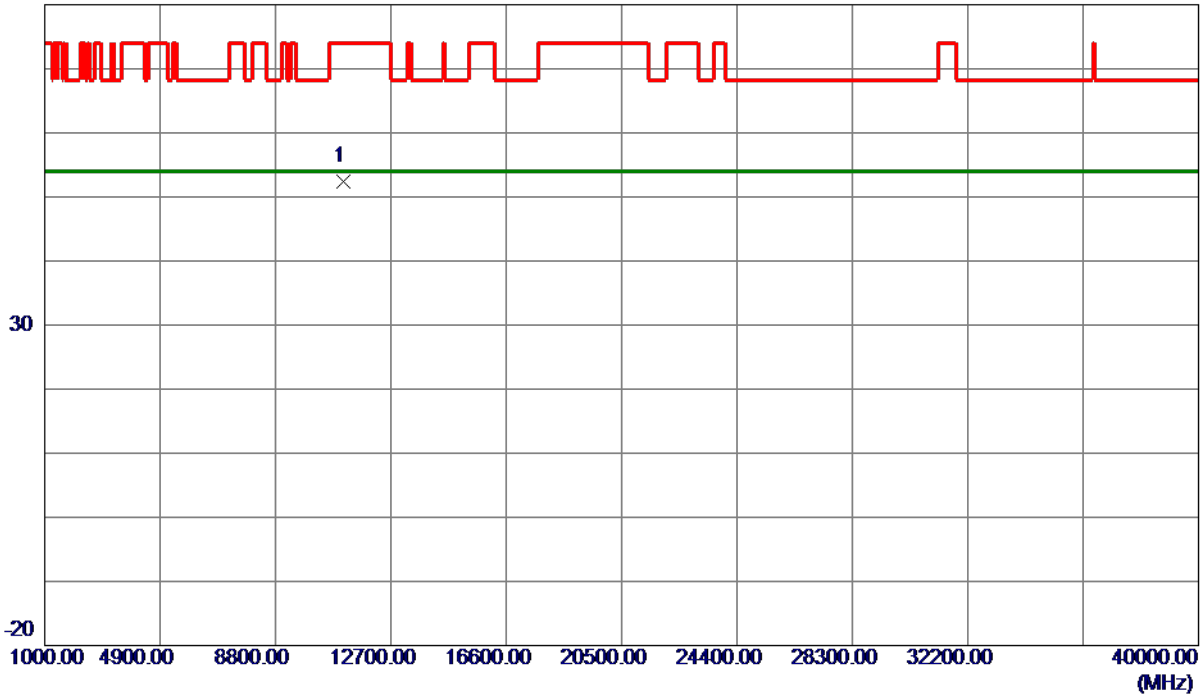

No.	Freq. MHz	Reading Level dBuV/m	Correct Factor dB	Measure ment dBuV/m	Limit dBuV/m	Margin dB	Detector	Comment
1 *	11100.8640	38.40	14.05	52.45	74.00	-21.55	Peak	

REMARKS:

- (1) Measurement Value = Reading Level + Correct Factor.
- (2) Margin Level = Measurement Value - Limit Value.

Orthogonal Axis	X
Test Mode	UNII-2C_TX AC (VHT40) Mode 5670 MHz

Vertical

130 dBuV/m

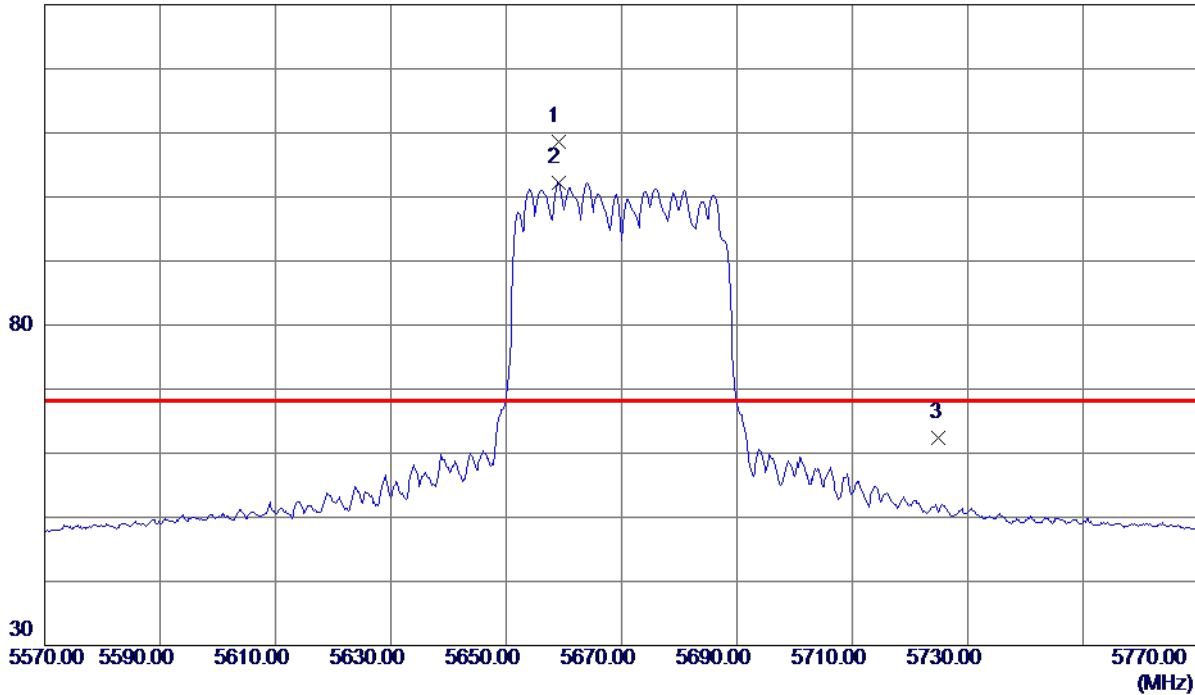

No.	Freq. MHz	Reading Level dBuV/m	Correct Factor dB	Measure ment dBuV/m	Limit dBuV/m	Margin dB	Detector	Comment
1 *	5659.0000	91.06	17.46	108.52	68.30	40.22	Peak	No Limit
2	5659.0000	84.81	17.46	102.27	999.00	-896.73	AVG	No Limit
3	5725.0000	44.72	17.65	62.37	68.30	-5.93	Peak	

REMARKS:

- (1) Measurement Value = Reading Level + Correct Factor.
- (2) Margin Level = Measurement Value - Limit Value.

Orthogonal Axis	X
Test Mode	UNII-2C_TX AC (VHT40) Mode 5670 MHz

Vertical

80 dBuV/m

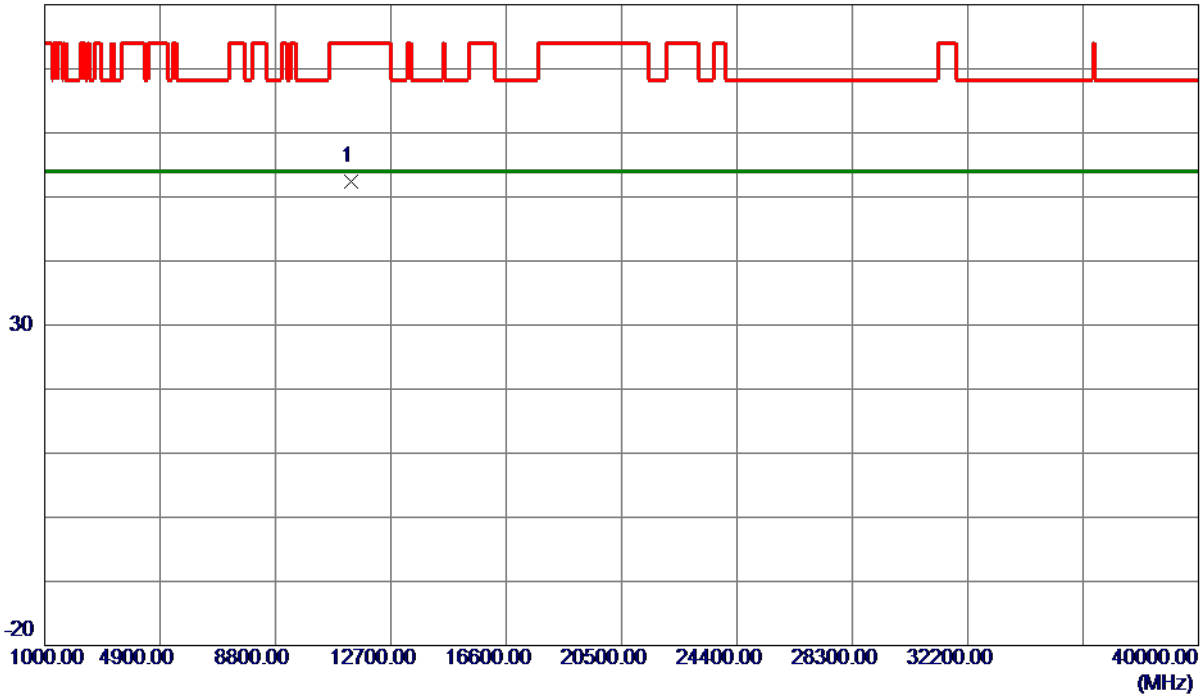

No.	Freq. MHz	Reading Level dBuV/m	Correct Factor dB	Measure ment dBuV/m	Limit dBuV/m	Margin dB	Detector	Comment
1 *	11340.2280	38.10	14.36	52.46	74.00	-21.54	Peak	

REMARKS:

- (1) Measurement Value = Reading Level + Correct Factor.
- (2) Margin Level = Measurement Value - Limit Value.

Orthogonal Axis	X
Test Mode	UNII-2C_TX AC (VHT40) Mode 5670 MHz

Horizontal

130 dBuV/m

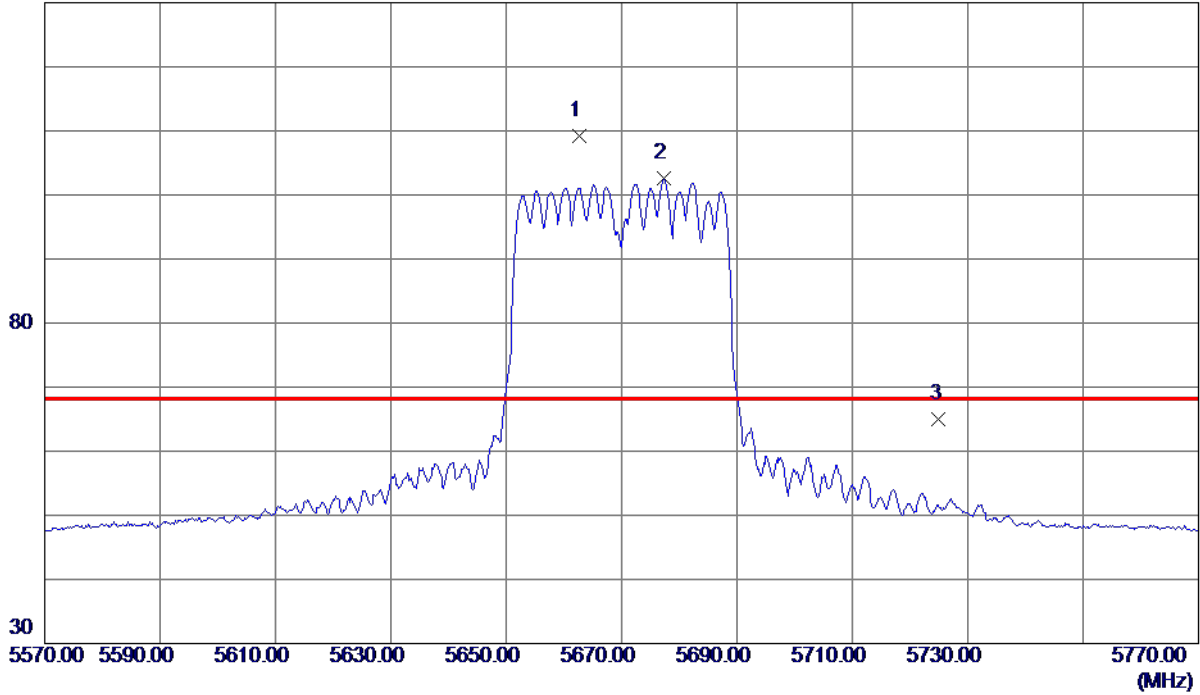

No.	Freq. MHz	Reading Level dBuV/m	Correct Factor dB	Measure ment dBuV/m	Limit dBuV/m	Margin dB	Detector	Comment
1 *	5662.6000	91.73	17.47	109.20	68.30	40.90	Peak	No Limit
2	5677.4000	85.11	17.51	102.62	999.00	-896.38	AVG	No Limit
3	5725.0000	47.44	17.65	65.09	68.30	-3.21	Peak	

REMARKS:

- (1) Measurement Value = Reading Level + Correct Factor.
- (2) Margin Level = Measurement Value - Limit Value.

Orthogonal Axis	X
Test Mode	UNII-2C_TX AC (VHT40) Mode 5670 MHz

Horizontal

80 dBuV/m



No.	Freq. MHz	Reading Level dBuV/m	Correct Factor dB	Measure ment dBuV/m	Limit dBuV/m	Margin dB	Detector	Comment
1 *	11339.1280	38.04	14.36	52.40	74.00	-21.60	Peak	

REMARKS:

- (1) Measurement Value = Reading Level + Correct Factor.
- (2) Margin Level = Measurement Value - Limit Value.

Orthogonal Axis	X
Test Mode	UNII-2C_TX AC (VHT80) Mode 5530 MHz

Vertical

130 dBuV/m

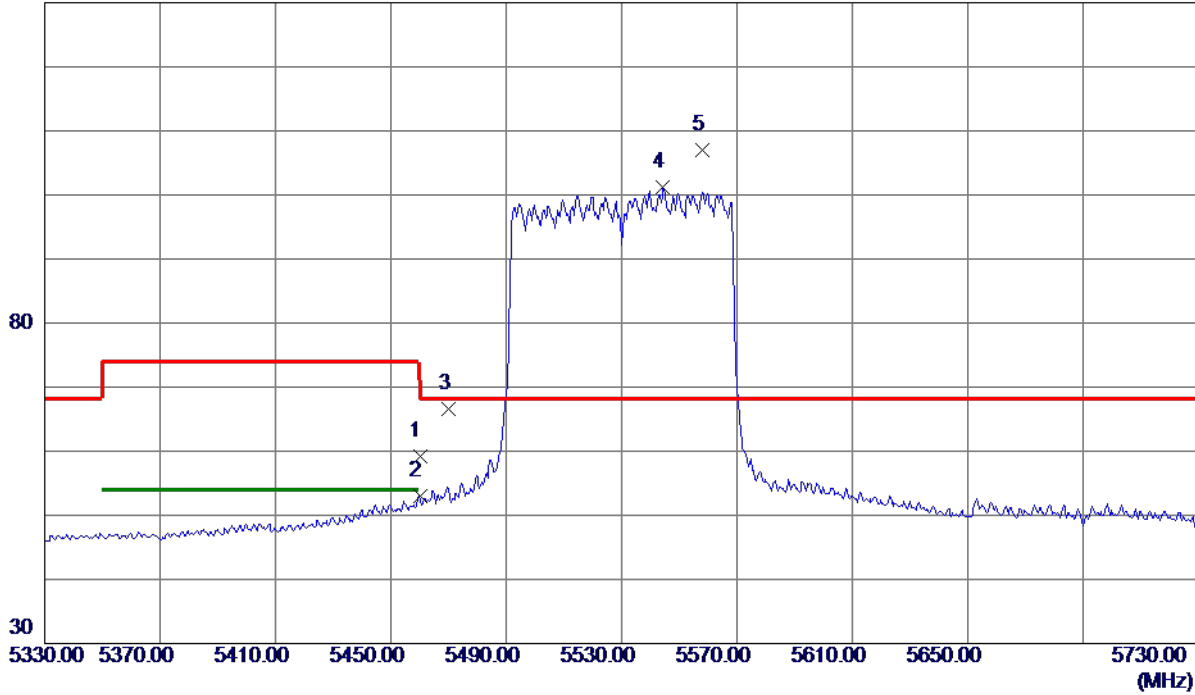

No.	Freq. MHz	Reading Level dBuV/m	Correct Factor dB	Measure ment dBuV/m	Limit dBuV/m	Margin dB	Detector	Comment
1	5460.0000	42.40	16.89	59.29	74.00	-14.71	Peak	
2	5460.0000	36.17	16.89	53.06	54.00	-0.94	AVG	
3	5470.0000	49.66	16.91	66.57	68.30	-1.73	Peak	
4	5544.4000	84.02	17.12	101.14	999.00	-897.86	AVG	No Limit
5 *	5558.0000	89.83	17.16	106.99	68.30	38.69	Peak	No Limit

REMARKS:

- (1) Measurement Value = Reading Level + Correct Factor.
- (2) Margin Level = Measurement Value - Limit Value.

Orthogonal Axis	X
Test Mode	UNII-2C_TX AC (VHT80) Mode 5530 MHz

Vertical

80 dBuV/m

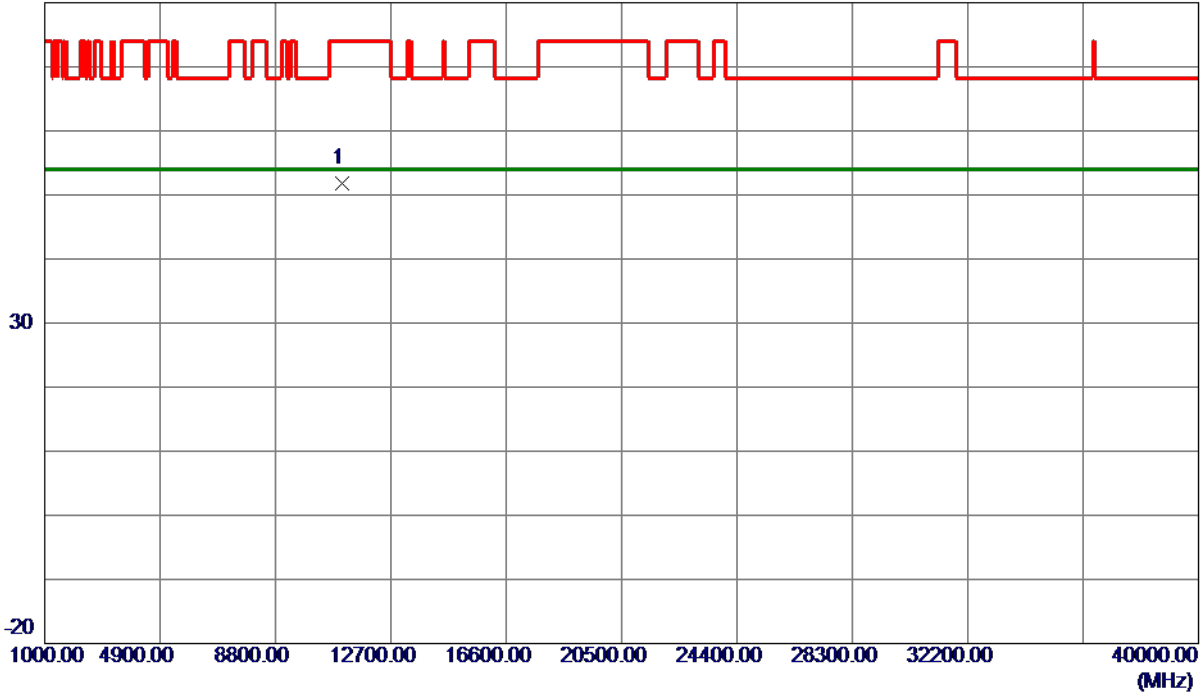

No.	Freq. MHz	Reading Level dBuV/m	Correct Factor dB	Measure ment dBuV/m	Limit dBuV/m	Margin dB	Detector	Comment
1 *	11059.9680	37.88	14.00	51.88	74.00	-22.12	Peak	

REMARKS:

- (1) Measurement Value = Reading Level + Correct Factor.
- (2) Margin Level = Measurement Value - Limit Value.

Orthogonal Axis	X
Test Mode	UNII-2C_TX AC (VHT80) Mode 5530 MHz

Horizontal

130 dBuV/m

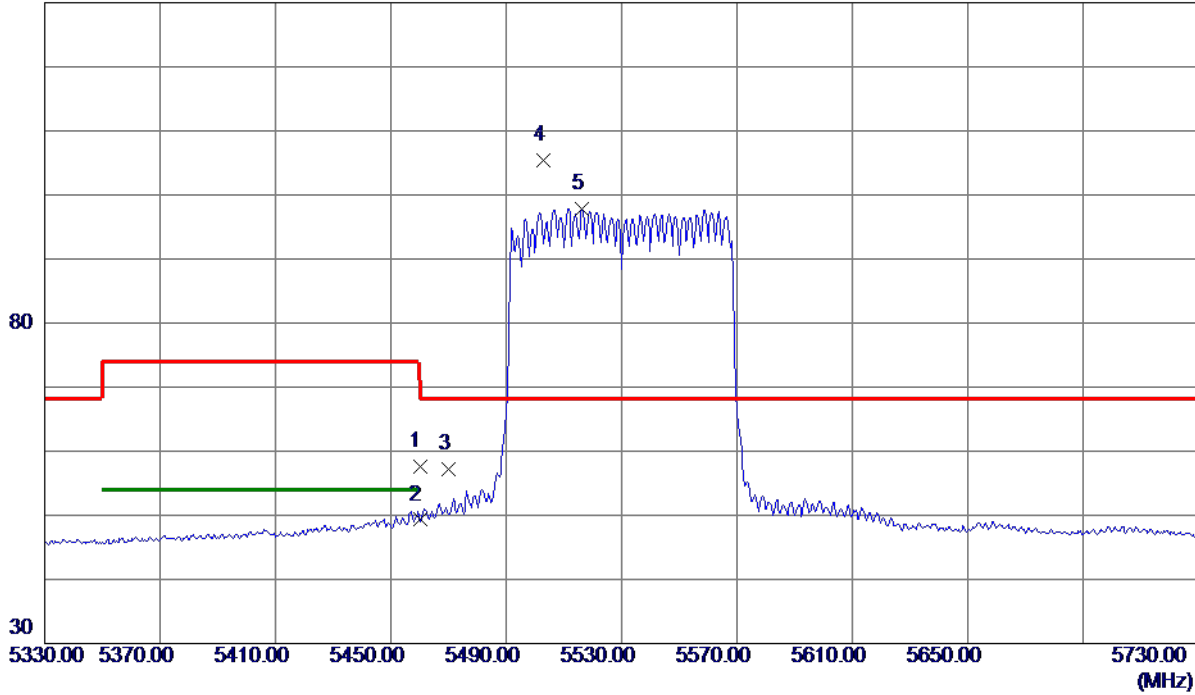

No.	Freq. MHz	Reading Level dBuV/m	Correct Factor dB	Measure ment dBuV/m	Limit dBuV/m	Margin dB	Detector	Comment
1	5460.0000	40.67	16.89	57.56	74.00	-16.44	Peak	
2	5460.0000	32.41	16.89	49.30	54.00	-4.70	AVG	
3	5470.0000	40.24	16.91	57.15	68.30	-11.15	Peak	
4 *	5502.8000	88.41	16.99	105.40	68.30	37.10	Peak	No Limit
5	5516.4000	80.85	17.03	97.88	999.00	-901.12	AVG	No Limit

REMARKS:

- (1) Measurement Value = Reading Level + Correct Factor.
- (2) Margin Level = Measurement Value - Limit Value.

Orthogonal Axis	X
Test Mode	UNII-2C_TX AC (VHT80) Mode 5530 MHz

Horizontal

80 dBuV/m

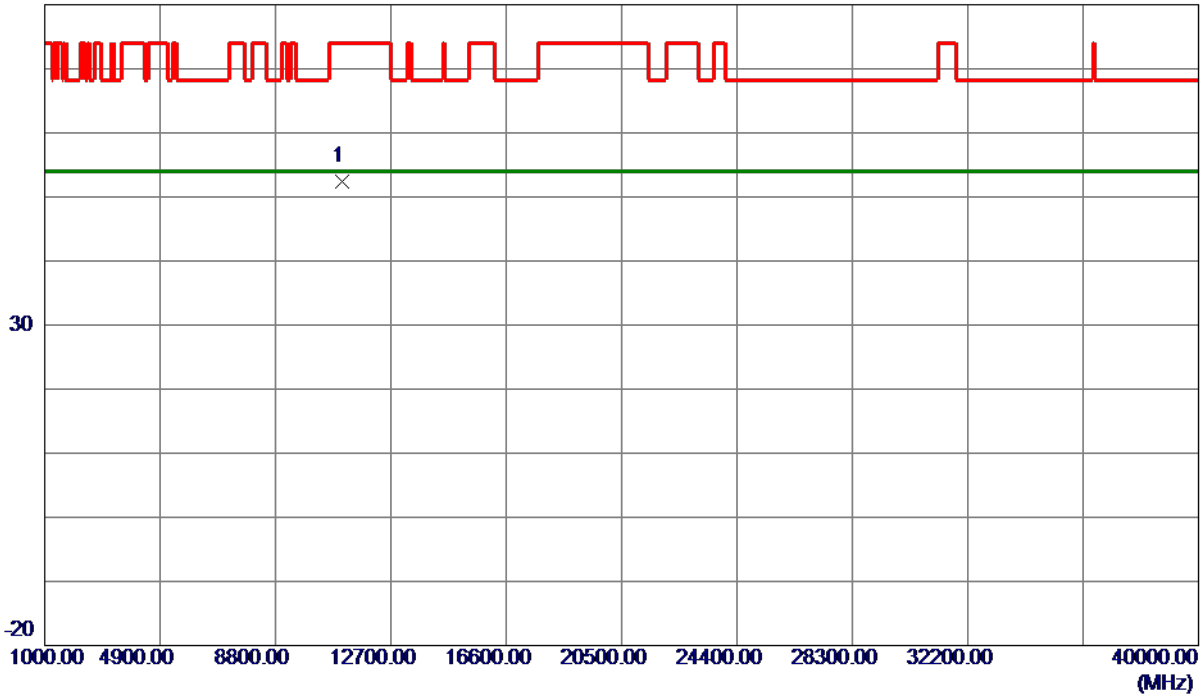

No.	Freq. MHz	Reading Level dBuV/m	Correct Factor dB	Measure ment dBuV/m	Limit dBuV/m	Margin dB	Detector	Comment
1 *	11060.9640	38.32	14.00	52.32	74.00	-21.68	Peak	

REMARKS:

- (1) Measurement Value = Reading Level + Correct Factor.
- (2) Margin Level = Measurement Value - Limit Value.

Orthogonal Axis	X
Test Mode	UNII-2C_TX AC (VHT80) Mode 5610 MHz

Vertical

130 dBuV/m

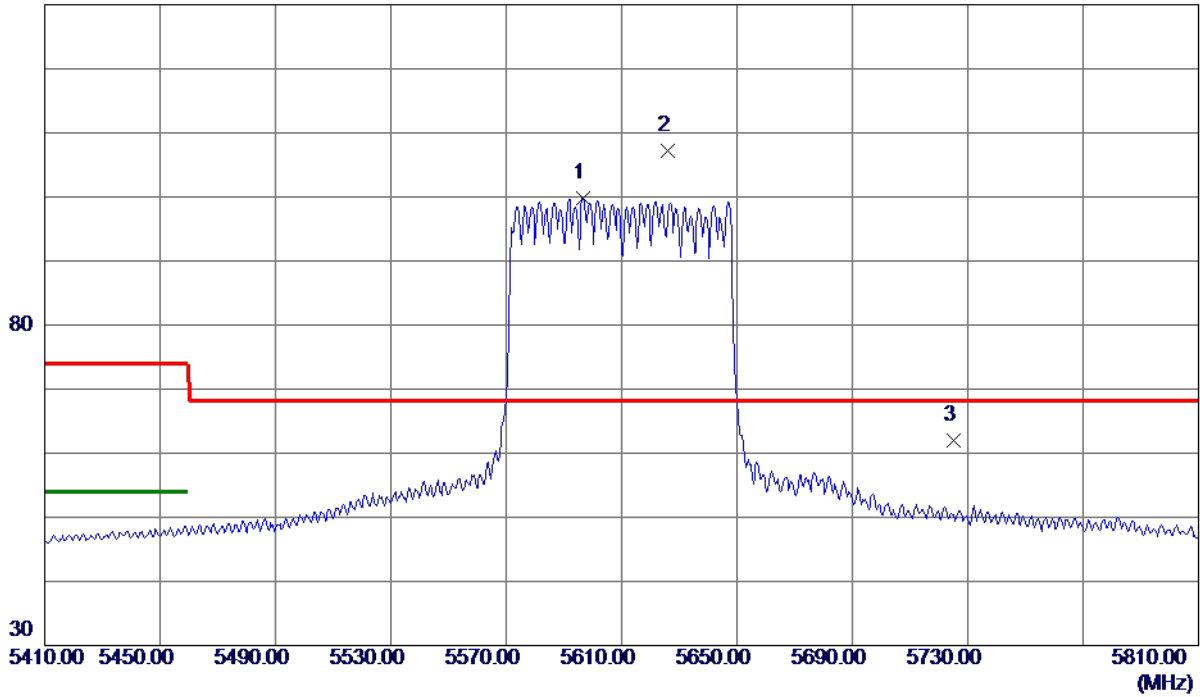

No.	Freq. MHz	Reading Level dBuV/m	Correct Factor dB	Measure ment dBuV/m	Limit dBuV/m	Margin dB	Detector	Comment
1	5596.8000	82.55	17.27	99.82	999.00	-899.18	AVG	No Limit
2 *	5626.0000	89.91	17.36	107.27	68.30	38.97	Peak	No Limit
3	5725.0000	44.38	17.65	62.03	68.30	-6.27	Peak	

REMARKS:

- (1) Measurement Value = Reading Level + Correct Factor.
- (2) Margin Level = Measurement Value - Limit Value.

Orthogonal Axis	X
Test Mode	UNII-2C_TX AC (VHT80) Mode 5610 MHz

Vertical

80 dBuV/m

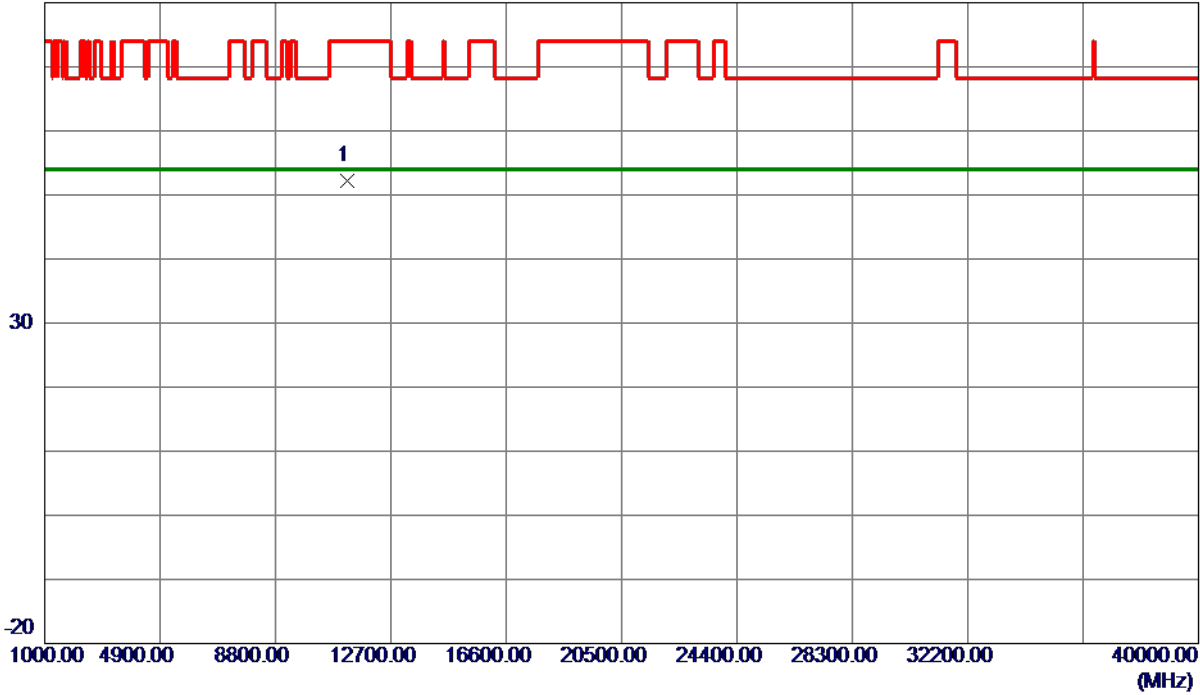

No.	Freq. MHz	Reading Level dBuV/m	Correct Factor dB	Measure ment dBuV/m	Limit dBuV/m	Margin dB	Detector	Comment
1 *	11219.6000	38.06	14.20	52.26	74.00	-21.74	Peak	

REMARKS:

- (1) Measurement Value = Reading Level + Correct Factor.
- (2) Margin Level = Measurement Value - Limit Value.

Orthogonal Axis	X
Test Mode	UNII-2C_TX AC (VHT80) Mode 5610 MHz

Horizontal

130 dBuV/m

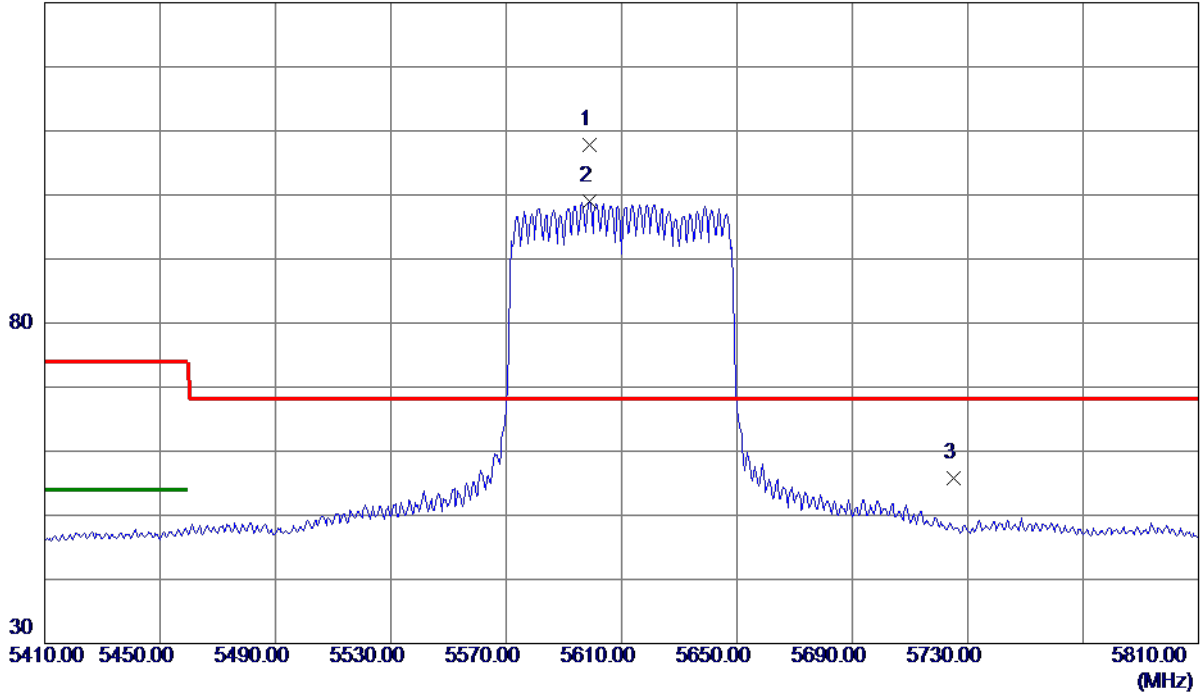

No.	Freq. MHz	Reading Level dBuV/m	Correct Factor dB	Measure ment dBuV/m	Limit dBuV/m	Margin dB	Detector	Comment
1 *	5598.8000	90.55	17.28	107.83	68.30	39.53	Peak	No Limit
2	5598.8000	81.70	17.28	98.98	999.00	-900.02	AVG	No Limit
3	5725.0000	38.19	17.65	55.84	68.30	-12.46	Peak	

REMARKS:

- (1) Measurement Value = Reading Level + Correct Factor.
- (2) Margin Level = Measurement Value - Limit Value.

Orthogonal Axis	X
Test Mode	UNII-2C_TX AC (VHT80) Mode 5610 MHz

Horizontal

80 dBuV/m

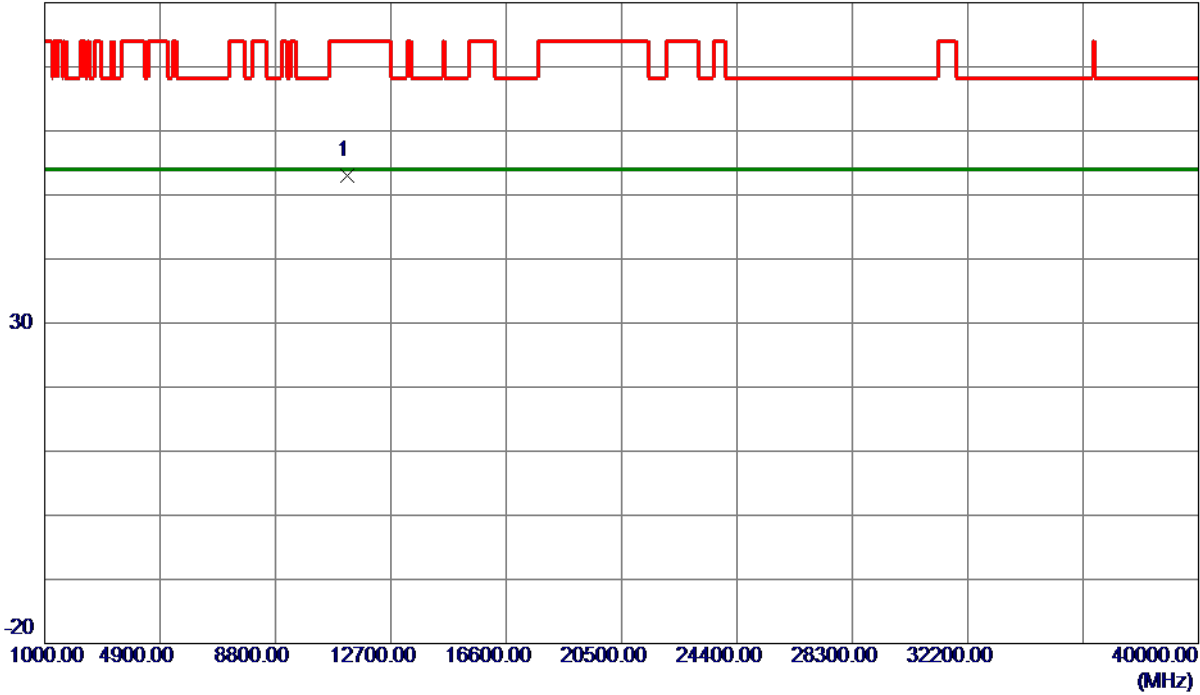

No.	Freq. MHz	Reading Level dBuV/m	Correct Factor dB	Measure ment dBuV/m	Limit dBuV/m	Margin dB	Detector	Comment
1 *	11219.1020	38.85	14.20	53.05	74.00	-20.95	Peak	

REMARKS:

- (1) Measurement Value = Reading Level + Correct Factor.
- (2) Margin Level = Measurement Value - Limit Value.

Orthogonal Axis	X
Test Mode	UNII-3_TX AC (VHT20) Mode 5745 MHz

Vertical

130 dBuV/m

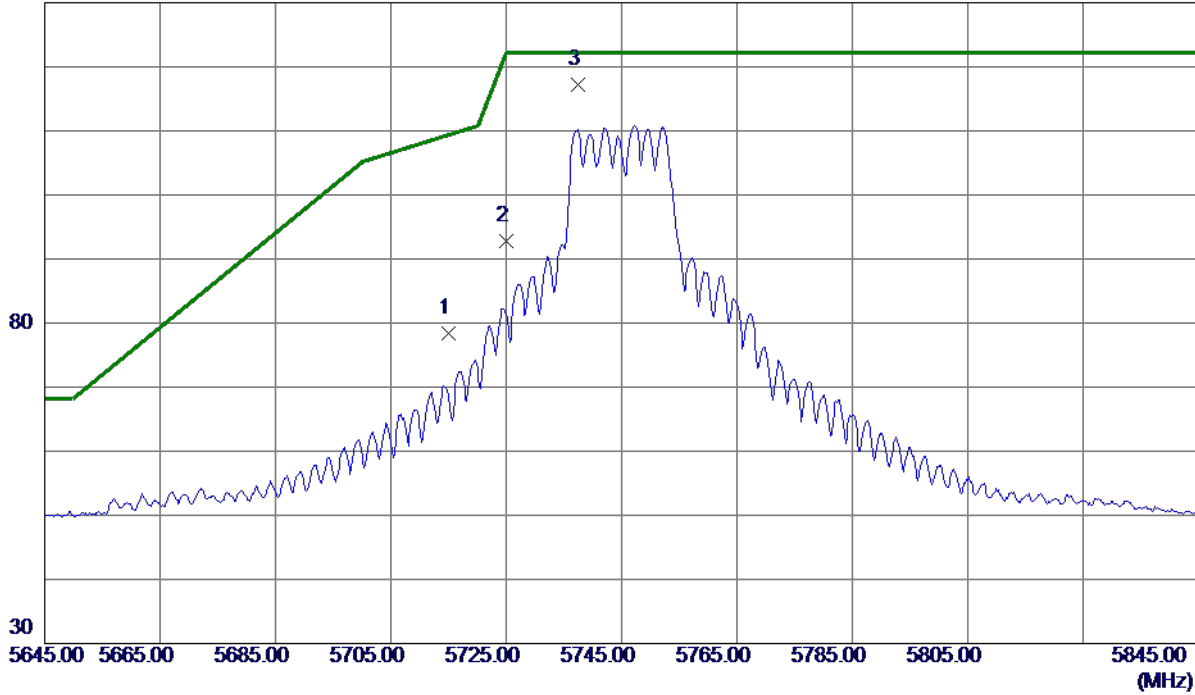

No.	Freq. MHz	Reading Level dBuV/m	Correct Factor dB	Measure ment dBuV/m	Limit dBuV/m	Margin dB	Detector	Comment
1	5715.0000	60.80	17.62	78.42	109.40	-30.98	Peak	
2	5725.0000	75.23	17.65	92.88	122.20	-29.32	Peak	
3 *	5737.4000	99.44	17.69	117.13	122.20	-5.07	Peak	No Limit

REMARKS:

- (1) Measurement Value = Reading Level + Correct Factor.
- (2) Margin Level = Measurement Value - Limit Value.

Orthogonal Axis	X
Test Mode	UNII-3_TX AC (VHT20) Mode 5745 MHz

Vertical

80 dBuV/m

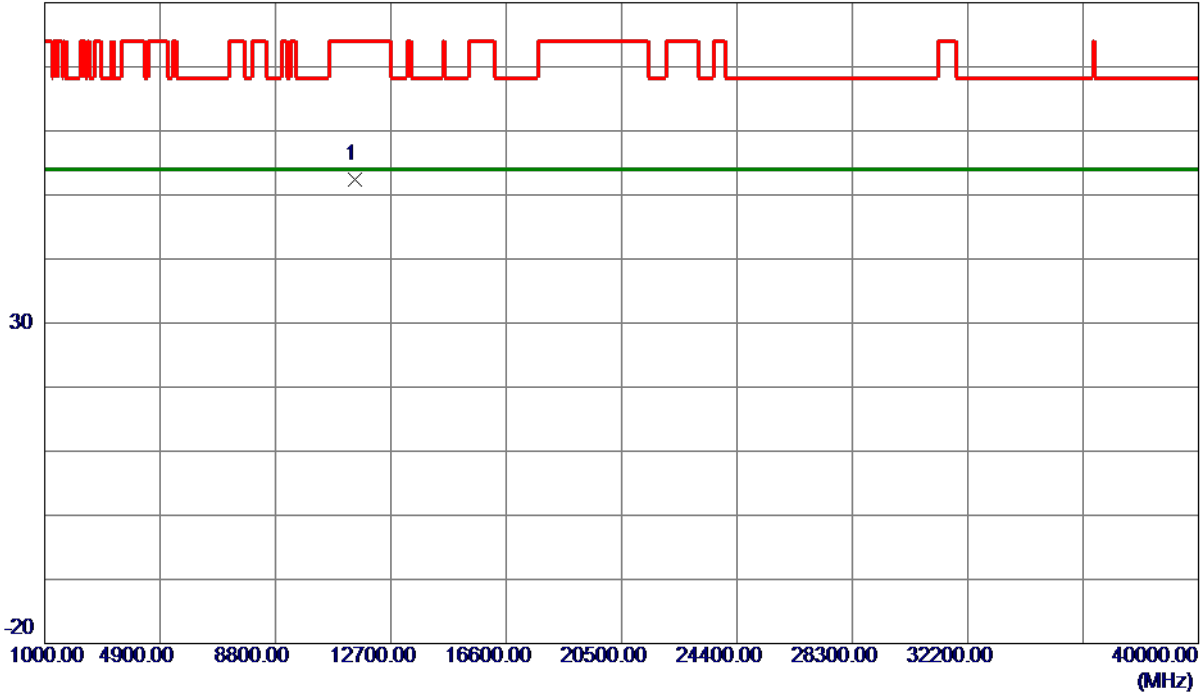

No.	Freq. MHz	Reading Level dBuV/m	Correct Factor dB	Measure ment dBuV/m	Limit dBuV/m	Margin dB	Detector	Comment
1 *	11492.7400	37.85	14.56	52.41	74.00	-21.59	Peak	

REMARKS:

- (1) Measurement Value = Reading Level + Correct Factor.
- (2) Margin Level = Measurement Value - Limit Value.

Orthogonal Axis	X
Test Mode	UNII-3_TX AC (VHT20) Mode 5745 MHz

Horizontal

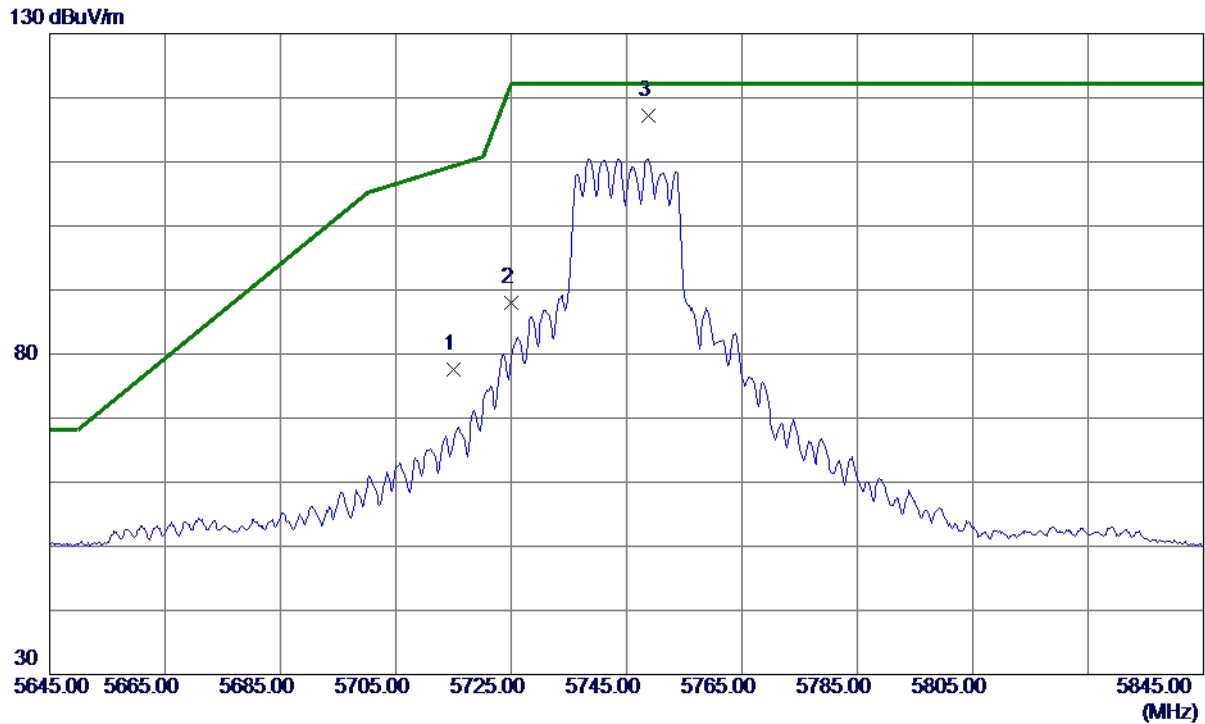

No.	Freq. MHz	Reading Level dBuV/m	Correct Factor dB	Measure ment dBuV/m	Limit dBuV/m	Margin dB	Detector	Comment
1	5715.0000	59.93	17.62	77.55	109.40	-31.85	Peak	
2	5725.0000	70.44	17.65	88.09	122.20	-34.11	Peak	
3 *	5748.8000	99.54	17.72	117.26	122.20	-4.94	Peak	No Limit

REMARKS:

- (1) Measurement Value = Reading Level + Correct Factor.
- (2) Margin Level = Measurement Value - Limit Value.

Orthogonal Axis	X
Test Mode	UNII-3_TX AC (VHT20) Mode 5745 MHz

Horizontal

80 dBuV/m

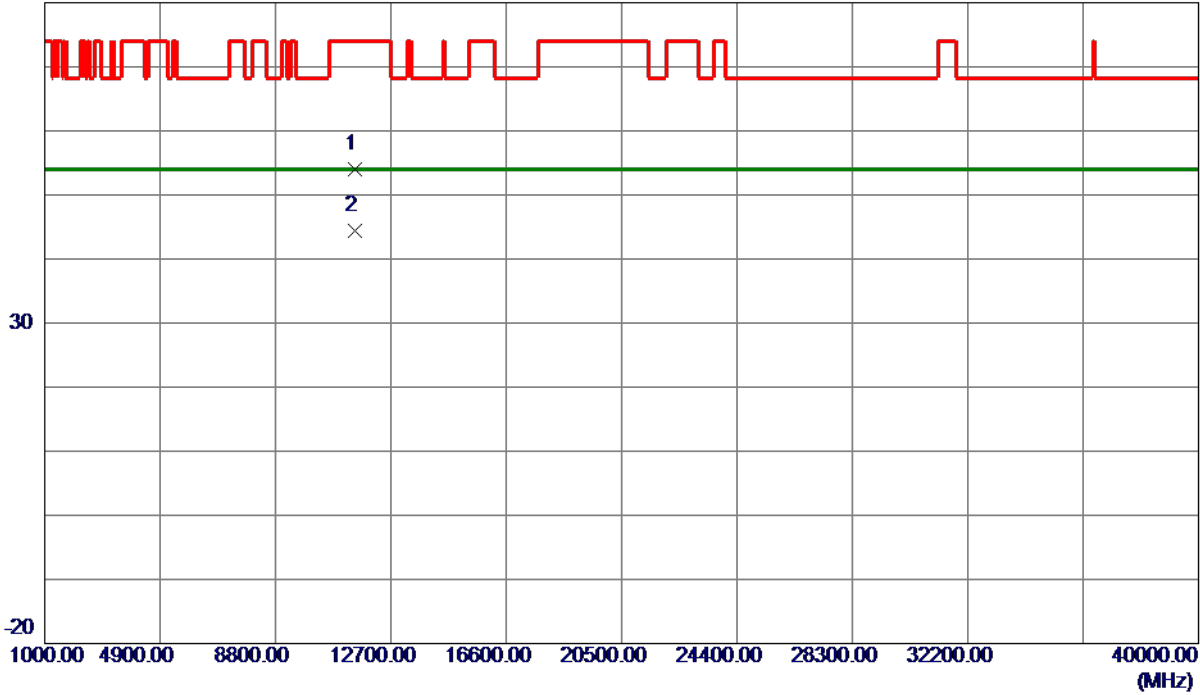

No.	Freq. MHz	Reading Level dBuV/m	Correct Factor dB	Measure ment dBuV/m	Limit dBuV/m	Margin dB	Detector	Comment
1	11490.5500	39.49	14.55	54.04	74.00	-19.96	Peak	
2 *	11490.6400	29.82	14.55	44.37	54.00	-9.63	AVG	

REMARKS:

- (1) Measurement Value = Reading Level + Correct Factor.
- (2) Margin Level = Measurement Value - Limit Value.

Orthogonal Axis	X
Test Mode	UNII-3_TX AC (VHT20) Mode 5785 MHz

Vertical

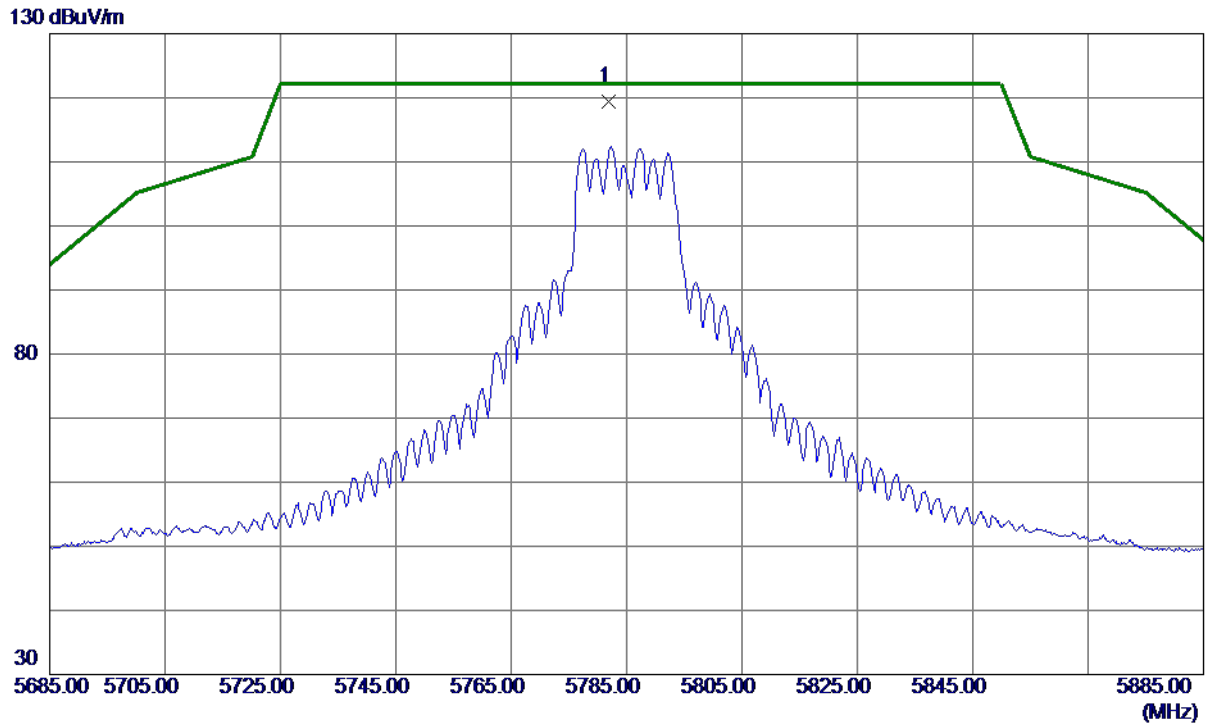

No.	Freq. MHz	Reading Level dBuV/m	Correct Factor dB	Measure ment dBuV/m	Limit dBuV/m	Margin dB	Detector	Comment
1 *	5781.8000	101.57	17.82	119.39	122.20	-2.81	Peak	No Limit

REMARKS:

- (1) Measurement Value = Reading Level + Correct Factor.
- (2) Margin Level = Measurement Value - Limit Value.

Orthogonal Axis	X
Test Mode	UNII-3_TX AC (VHT20) Mode 5785 MHz

Vertical

80 dBuV/m

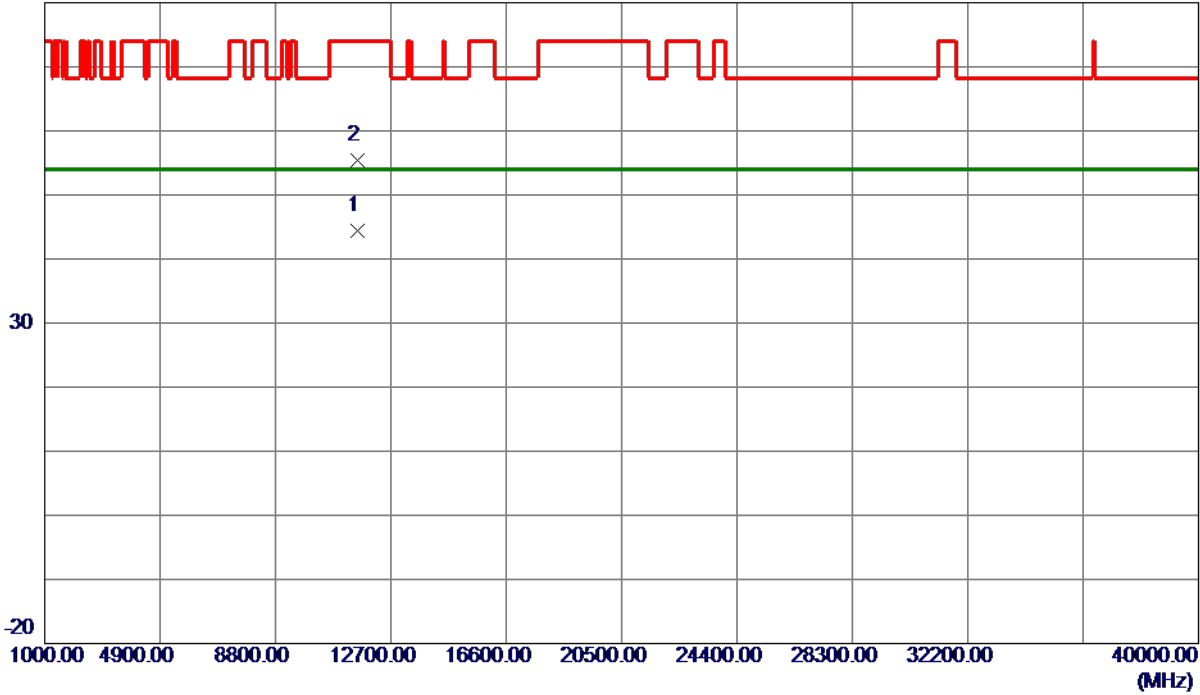

No.	Freq. MHz	Reading Level dBuV/m	Correct Factor dB	Measure ment dBuV/m	Limit dBuV/m	Margin dB	Detector	Comment
1 *	11570.4700	29.74	14.57	44.31	54.00	-9.69	AVG	
2	11570.6400	40.79	14.57	55.36	74.00	-18.64	Peak	

REMARKS:

- (1) Measurement Value = Reading Level + Correct Factor.
- (2) Margin Level = Measurement Value - Limit Value.

Orthogonal Axis	X
Test Mode	UNII-3_TX AC (VHT20) Mode 5785 MHz

Horizontal

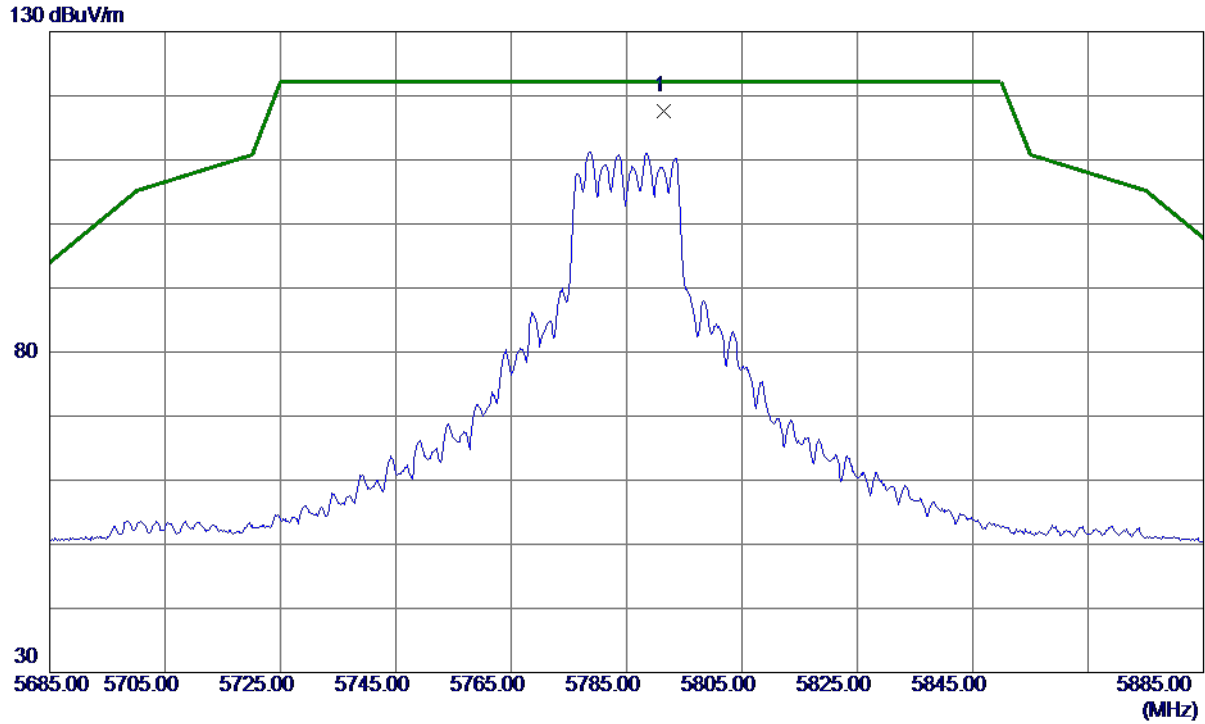

No.	Freq. MHz	Reading Level dBuV/m	Correct Factor dB	Measure ment dBuV/m	Limit dBuV/m	Margin dB	Detector	Comment
1 *	5791.4000	99.82	17.85	117.67	122.20	-4.53	Peak	No Limit

REMARKS:

- (1) Measurement Value = Reading Level + Correct Factor.
- (2) Margin Level = Measurement Value - Limit Value.

Orthogonal Axis	X
Test Mode	UNII-3_TX AC (VHT20) Mode 5785 MHz

Horizontal

80 dBuV/m

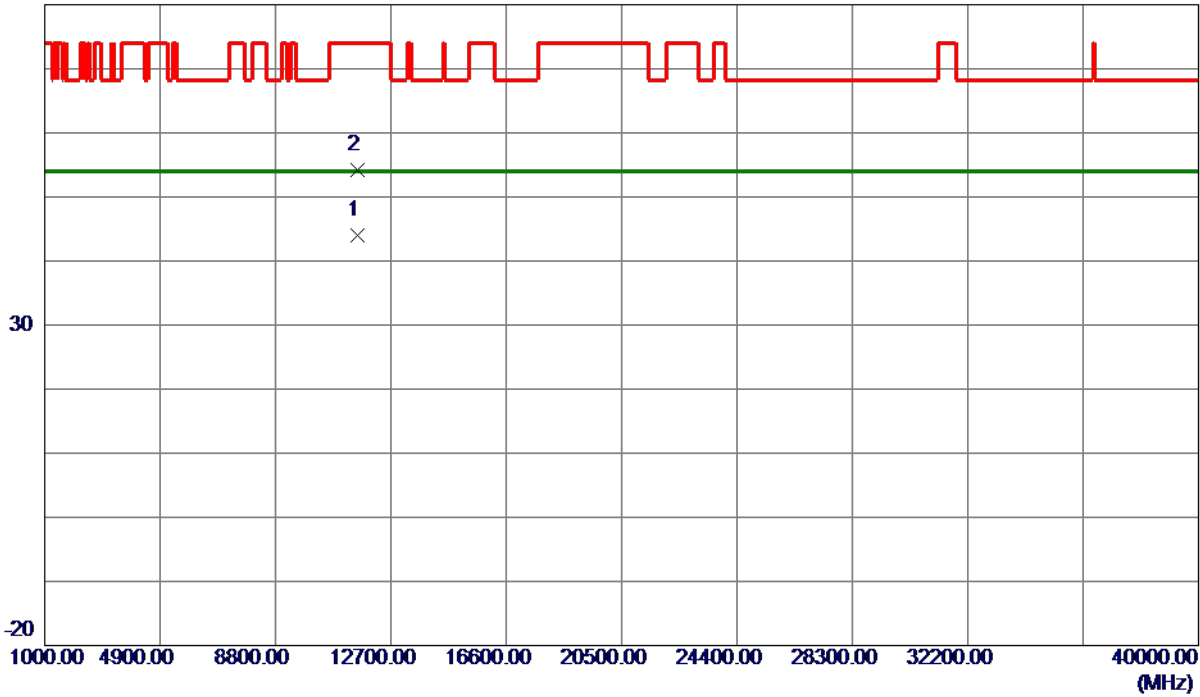

No.	Freq. MHz	Reading Level dBuV/m	Correct Factor dB	Measure ment dBuV/m	Limit dBuV/m	Margin dB	Detector	Comment
1 *	11570.2150	29.50	14.57	44.07	54.00	-9.93	AVG	
2	11570.4700	39.69	14.57	54.26	74.00	-19.74	Peak	

REMARKS:

- (1) Measurement Value = Reading Level + Correct Factor.
- (2) Margin Level = Measurement Value - Limit Value.

Orthogonal Axis	X
Test Mode	UNII-3_TX AC (VHT20) Mode 5825 MHz

Vertical

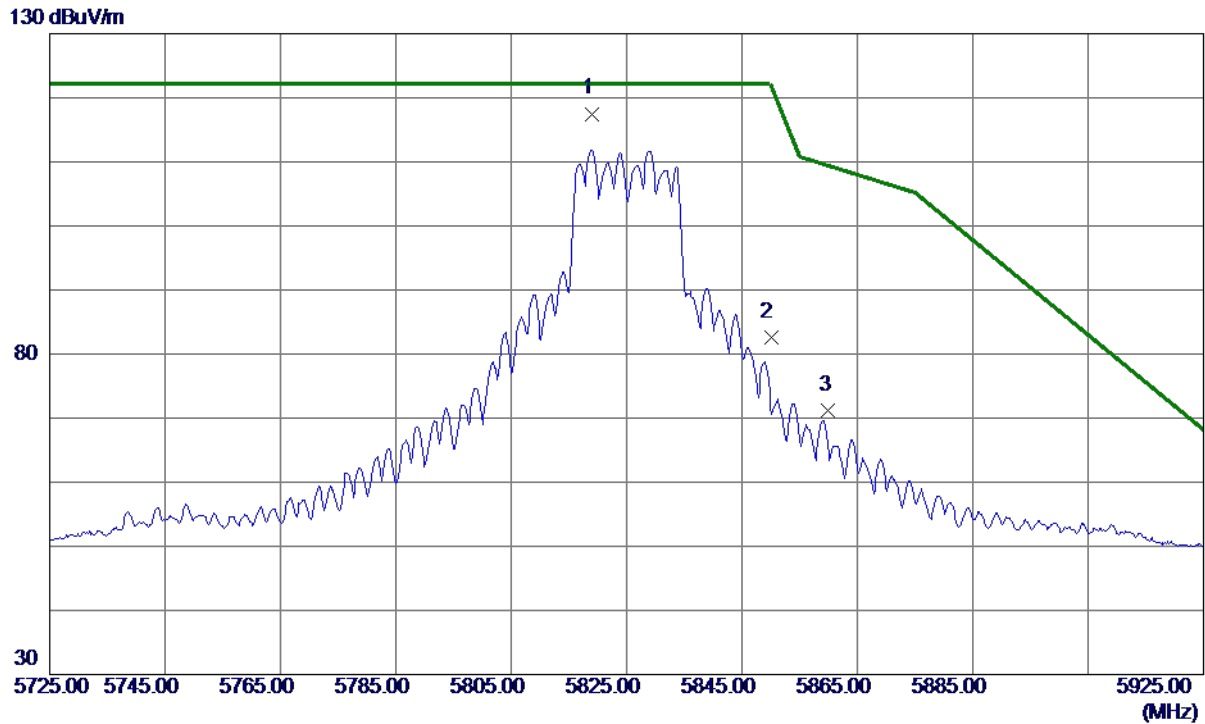

No.	Freq. MHz	Reading Level dBuV/m	Correct Factor dB	Measure ment dBuV/m	Limit dBuV/m	Margin dB	Detector	Comment
1 *	5819.0000	99.57	17.93	117.50	122.20	-4.70	Peak	No Limit
2	5850.0000	64.54	18.02	82.56	122.20	-39.64	Peak	
3	5860.0000	53.06	18.05	71.11	109.40	-38.29	Peak	

REMARKS:

- (1) Measurement Value = Reading Level + Correct Factor.
- (2) Margin Level = Measurement Value - Limit Value.

Orthogonal Axis	X
Test Mode	UNII-3_TX AC (VHT20) Mode 5825 MHz

Vertical

80 dBuV/m

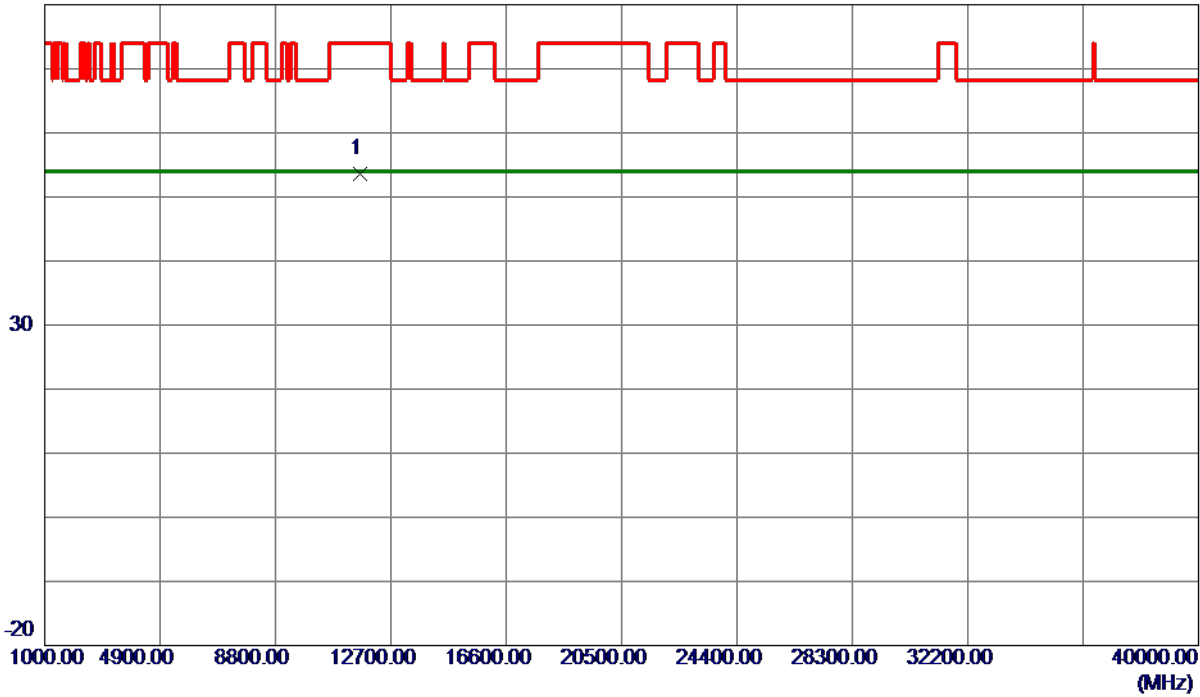

No.	Freq. MHz	Reading Level dBuV/m	Correct Factor dB	Measure ment dBuV/m	Limit dBuV/m	Margin dB	Detector	Comment
1 *	11650.8500	39.12	14.57	53.69	74.00	-20.31	Peak	

REMARKS:

- (1) Measurement Value = Reading Level + Correct Factor.
- (2) Margin Level = Measurement Value - Limit Value.

Orthogonal Axis	X
Test Mode	UNII-3_TX AC (VHT20) Mode 5825 MHz

Horizontal

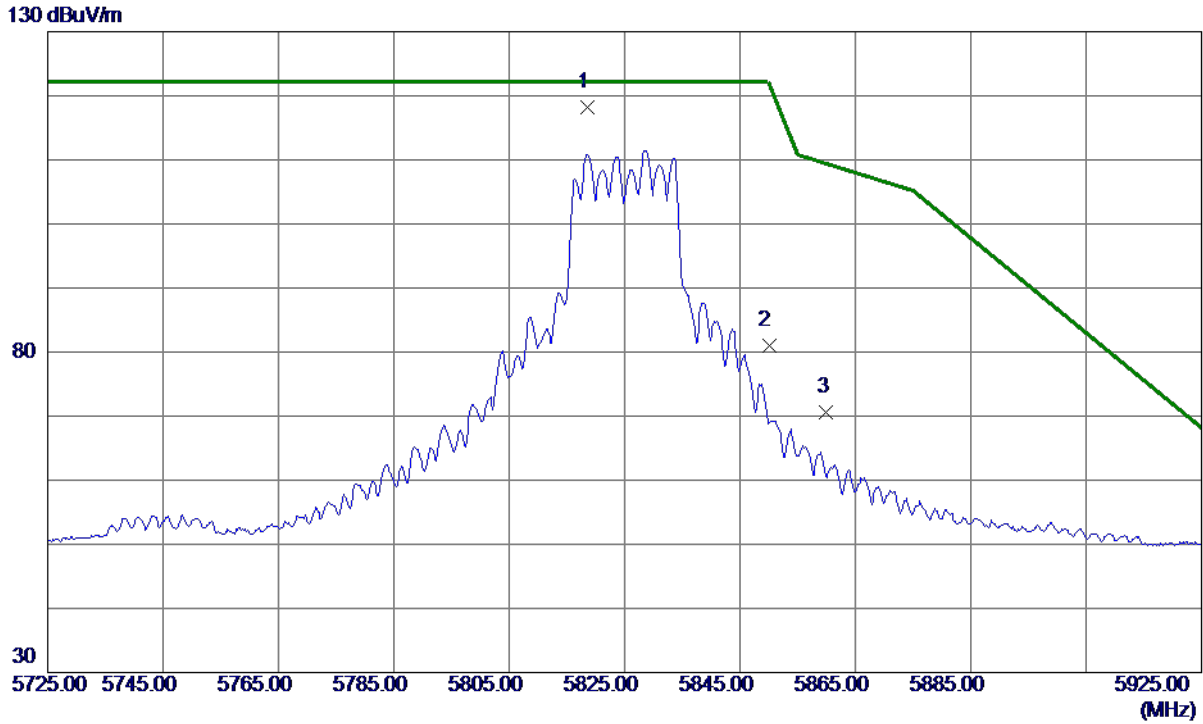

No.	Freq. MHz	Reading Level dBuV/m	Correct Factor dB	Measure ment dBuV/m	Limit dBuV/m	Margin dB	Detector	Comment
1 *	5818.6000	100.18	17.93	118.11	122.20	-4.09	Peak	No Limit
2	5850.0000	62.89	18.02	80.91	122.20	-41.29	Peak	
3	5860.0000	52.56	18.05	70.61	109.40	-38.79	Peak	

REMARKS:

- (1) Measurement Value = Reading Level + Correct Factor.
- (2) Margin Level = Measurement Value - Limit Value.

Orthogonal Axis	X
Test Mode	UNII-3_TX AC (VHT20) Mode 5825 MHz

Horizontal

80 dBuV/m

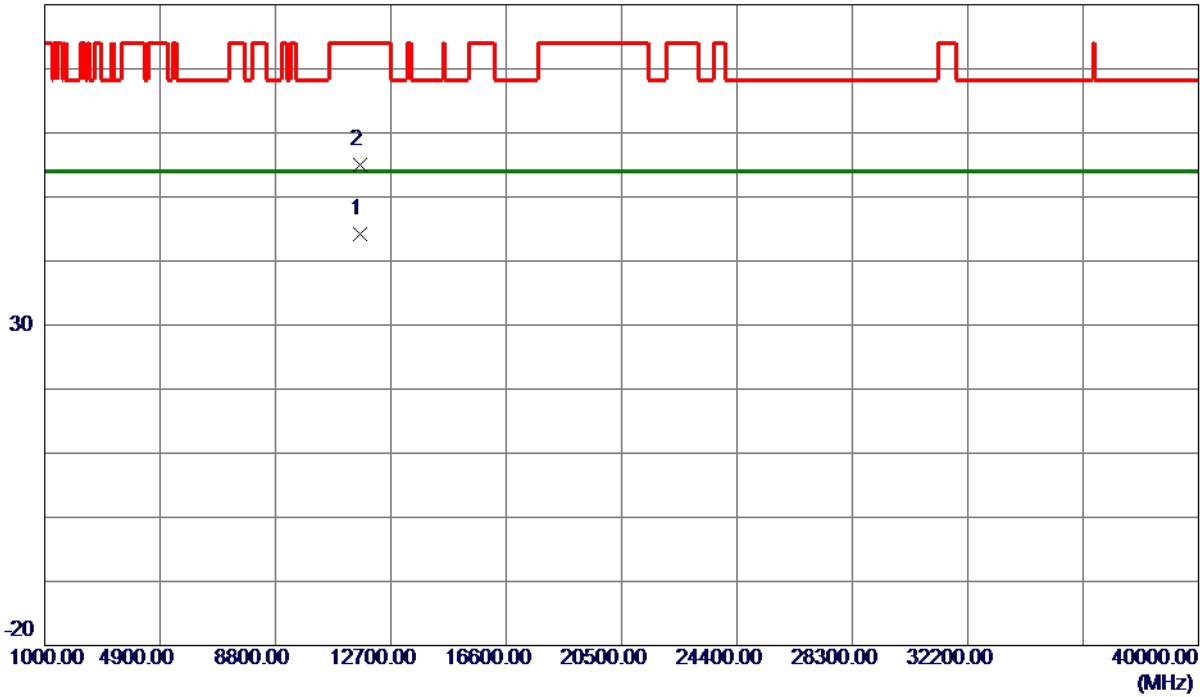

No.	Freq. MHz	Reading Level dBuV/m	Correct Factor dB	Measure ment dBuV/m	Limit dBuV/m	Margin dB	Detector	Comment
1 *	11650.4000	29.58	14.57	44.15	54.00	-9.85	AVG	
2	11650.4200	40.46	14.57	55.03	74.00	-18.97	Peak	

REMARKS:

- (1) Measurement Value = Reading Level + Correct Factor.
- (2) Margin Level = Measurement Value - Limit Value.

Orthogonal Axis	X
Test Mode	UNII-3_TX AC (VHT40) Mode 5755 MHz

Vertical

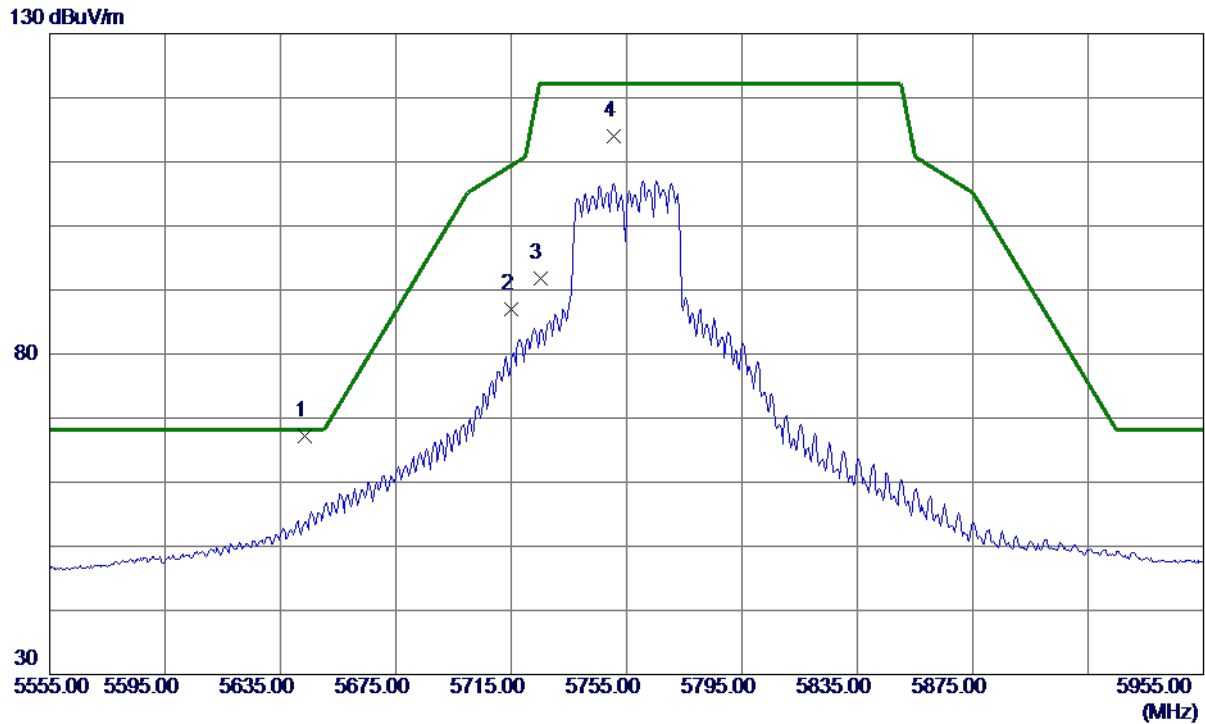

No.	Freq. MHz	Reading Level dBuV/m	Correct Factor dB	Measure ment dBuV/m	Limit dBuV/m	Margin dB	Detector	Comment
1 *	5643.4000	49.78	17.41	67.19	68.20	-1.01	Peak	
2	5715.0000	69.31	17.62	86.93	109.40	-22.47	Peak	
3	5725.0000	74.11	17.65	91.76	122.20	-30.44	Peak	
4	5750.6000	96.34	17.73	114.07	122.20	-8.13	Peak	No Limit

REMARKS:

- (1) Measurement Value = Reading Level + Correct Factor.
- (2) Margin Level = Measurement Value - Limit Value.

Orthogonal Axis	X
Test Mode	UNII-3_TX AC (VHT40) Mode 5755 MHz

Vertical

80 dBuV/m

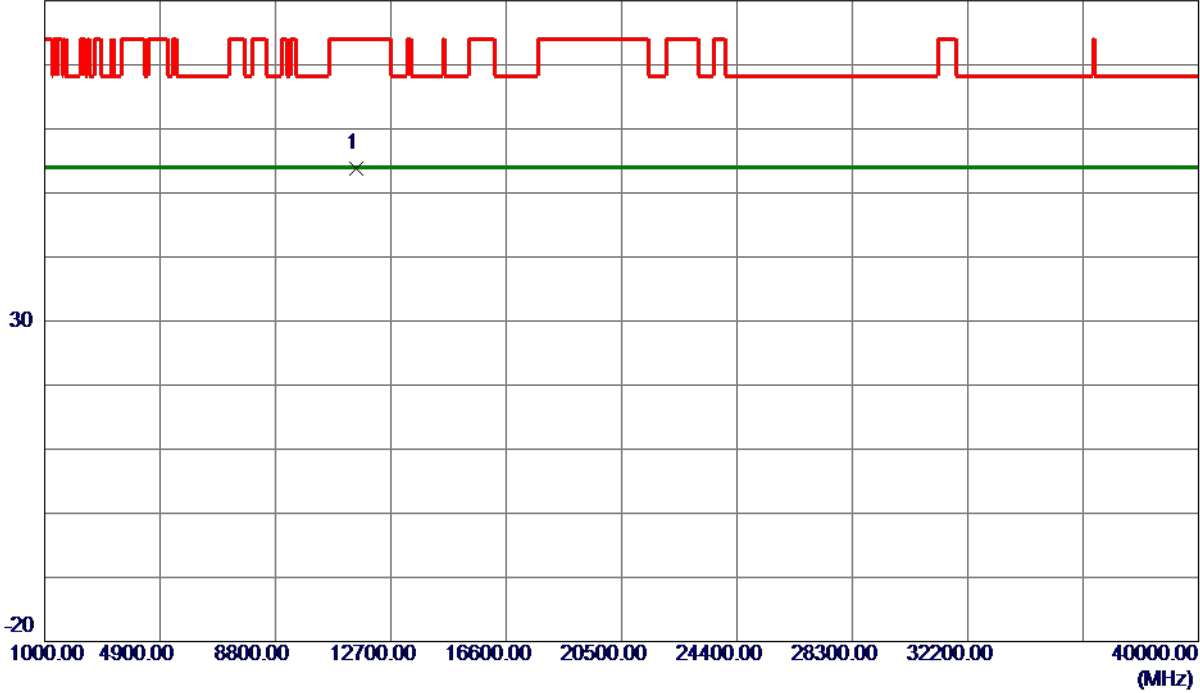

No.	Freq. MHz	Reading Level dBuV/m	Correct Factor dB	Measure ment dBuV/m	Limit dBuV/m	Margin dB	Detector	Comment
1 *	11510.3500	39.15	14.57	53.72	74.00	-20.28	Peak	

REMARKS:

- (1) Measurement Value = Reading Level + Correct Factor.
- (2) Margin Level = Measurement Value - Limit Value.

Orthogonal Axis	X
Test Mode	UNII-3_TX AC (VHT40) Mode 5755 MHz

Horizontal

130 dBuV/m

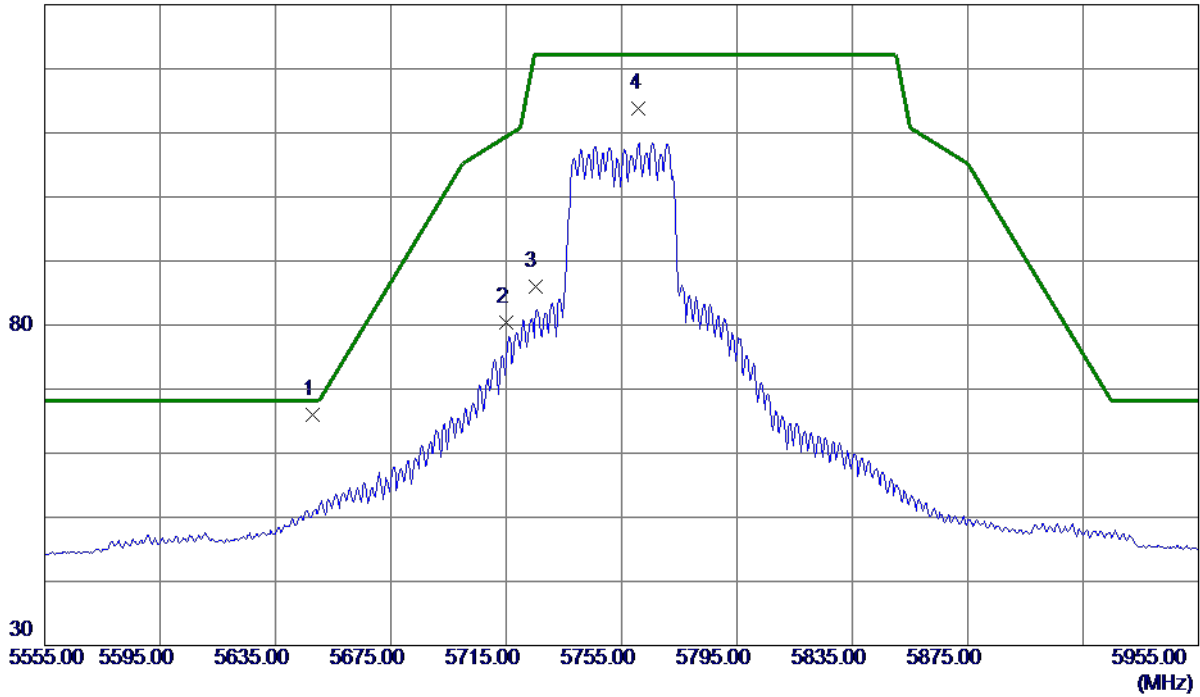

No.	Freq. MHz	Reading Level dBuV/m	Correct Factor dB	Measure ment dBuV/m	Limit dBuV/m	Margin dB	Detector	Comment
1 *	5648.0000	48.59	17.42	66.01	68.20	-2.19	Peak	
2	5715.0000	62.82	17.62	80.44	109.40	-28.96	Peak	
3	5725.0000	68.27	17.65	85.92	122.20	-36.28	Peak	
4	5761.0000	96.13	17.76	113.89	122.20	-8.31	Peak	No Limit

REMARKS:

- (1) Measurement Value = Reading Level + Correct Factor.
- (2) Margin Level = Measurement Value - Limit Value.

Orthogonal Axis	X
Test Mode	UNII-3_TX AC (VHT40) Mode 5755 MHz

Horizontal

80 dBuV/m

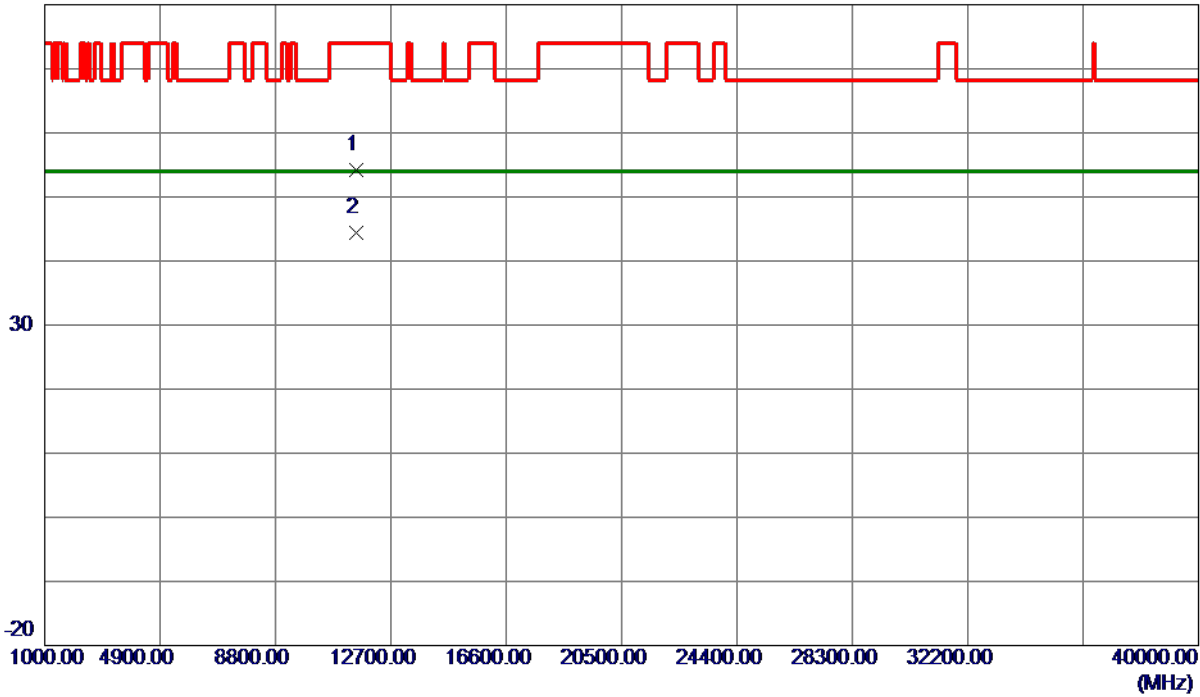

No.	Freq. MHz	Reading Level dBuV/m	Correct Factor dB	Measure ment dBuV/m	Limit dBuV/m	Margin dB	Detector	Comment
1	11510.4000	39.70	14.57	54.27	74.00	-19.73	Peak	
2 *	11511.2000	29.74	14.57	44.31	54.00	-9.69	AVG	

REMARKS:

- (1) Measurement Value = Reading Level + Correct Factor.
- (2) Margin Level = Measurement Value - Limit Value.

Orthogonal Axis	X
Test Mode	UNII-3_TX AC (VHT40) Mode 5795 MHz

Vertical

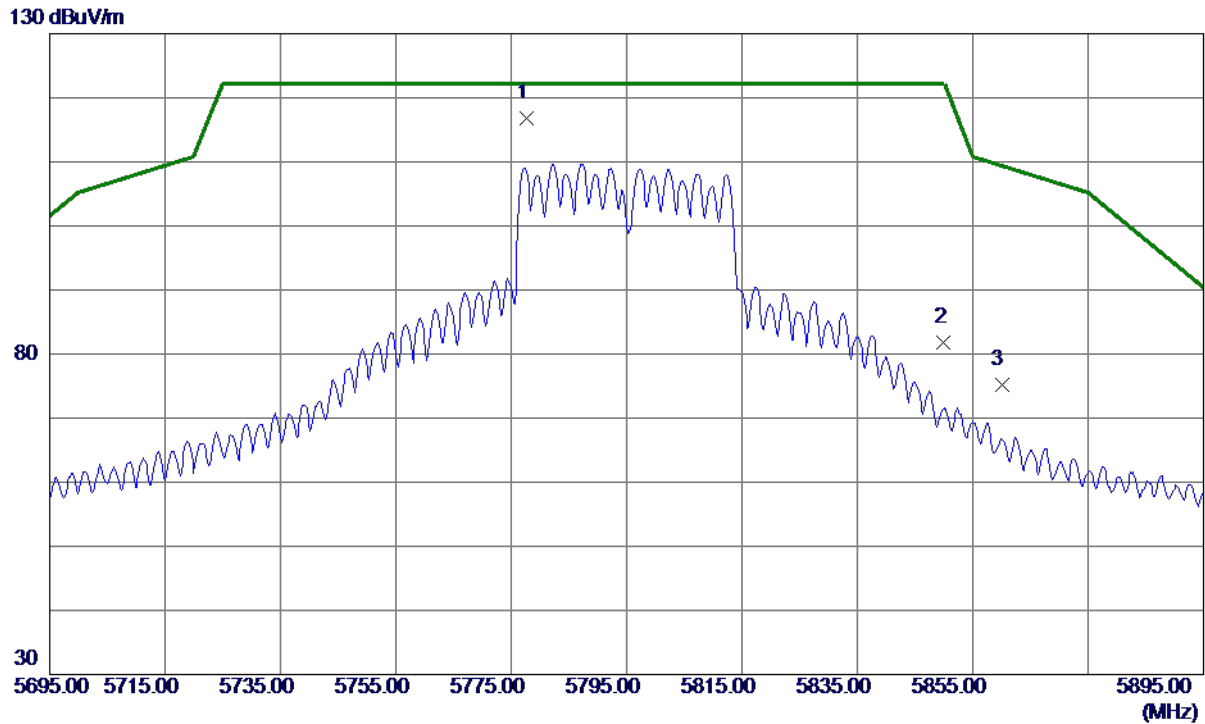

No.	Freq. MHz	Reading Level dBuV/m	Correct Factor dB	Measure ment dBuV/m	Limit dBuV/m	Margin dB	Detector	Comment
1 *	5777.6000	98.95	17.81	116.76	122.20	-5.44	Peak	No Limit
2	5850.0000	63.87	18.02	81.89	122.20	-40.31	Peak	
3	5860.0000	57.19	18.05	75.24	109.40	-34.16	Peak	

REMARKS:

- (1) Measurement Value = Reading Level + Correct Factor.
- (2) Margin Level = Measurement Value - Limit Value.

Orthogonal Axis	X
Test Mode	UNII-3_TX AC (VHT40) Mode 5795 MHz

Vertical

80 dBuV/m

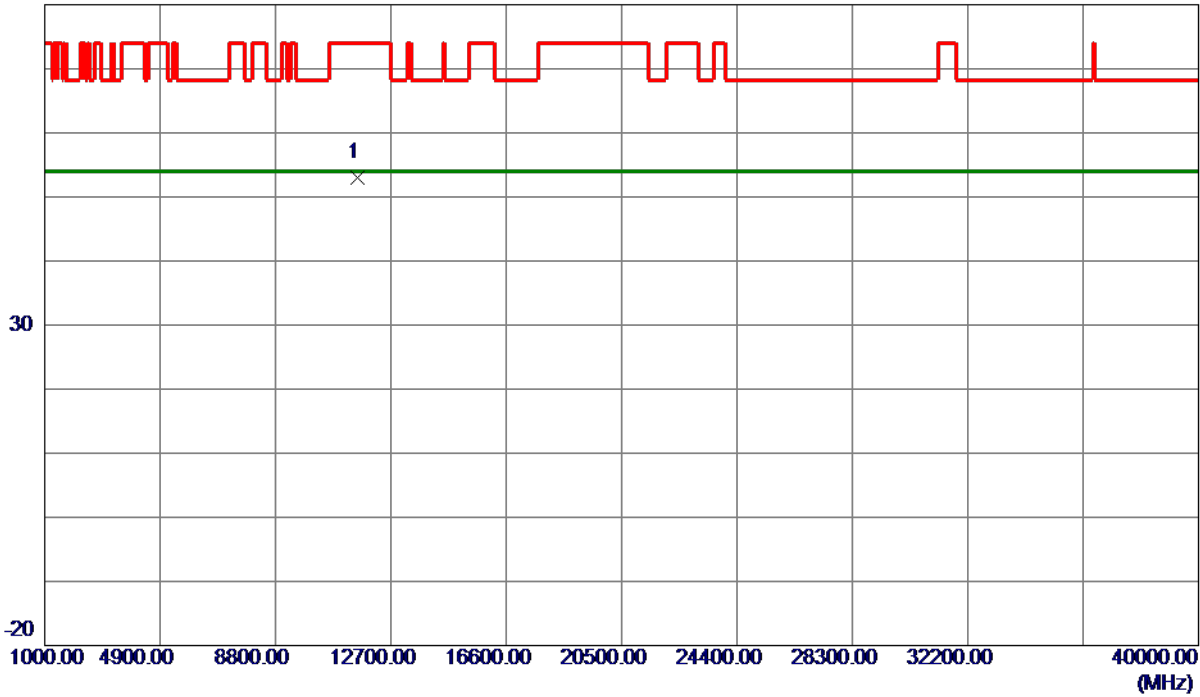

No.	Freq. MHz	Reading Level dBuV/m	Correct Factor dB	Measure ment dBuV/m	Limit dBuV/m	Margin dB	Detector	Comment
1 *	11590.5400	38.36	14.57	52.93	74.00	-21.07	Peak	

REMARKS:

- (1) Measurement Value = Reading Level + Correct Factor.
- (2) Margin Level = Measurement Value - Limit Value.

Orthogonal Axis	X
Test Mode	UNII-3_TX AC (VHT40) Mode 5795 MHz

Horizontal

130 dBuV/m

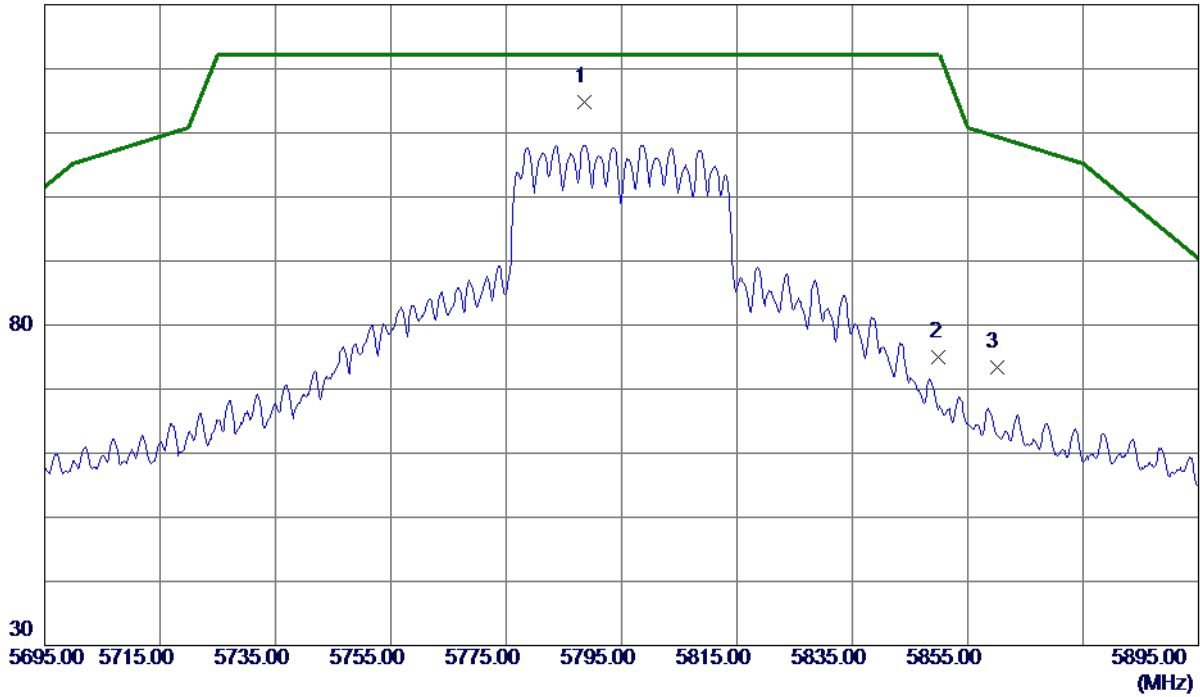

No.	Freq. MHz	Reading Level dBuV/m	Correct Factor dB	Measure ment dBuV/m	Limit dBuV/m	Margin dB	Detector	Comment
1 *	5788.6000	96.95	17.84	114.79	122.20	-7.41	Peak	No Limit
2	5850.0000	57.00	18.02	75.02	122.20	-47.18	Peak	
3	5860.0000	55.43	18.05	73.48	109.40	-35.92	Peak	

REMARKS:

- (1) Measurement Value = Reading Level + Correct Factor.
- (2) Margin Level = Measurement Value - Limit Value.

Orthogonal Axis	X
Test Mode	UNII-3_TX AC (VHT40) Mode 5795 MHz

Horizontal

80 dBuV/m

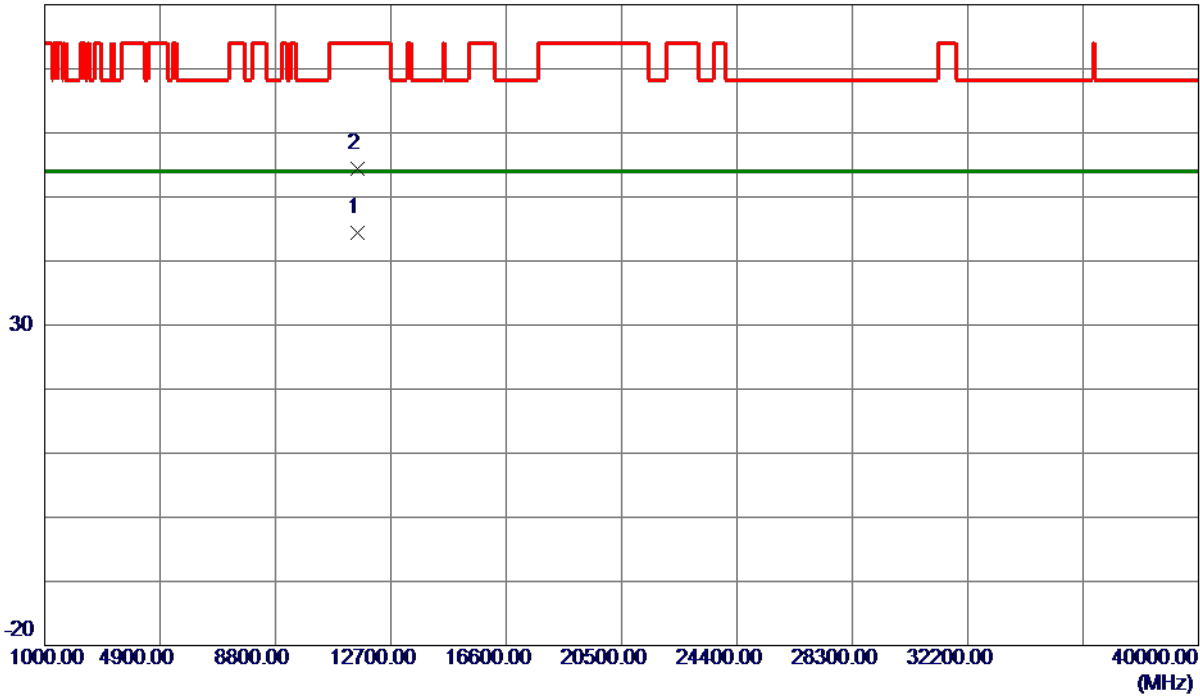

No.	Freq. MHz	Reading Level dBuV/m	Correct Factor dB	Measure ment dBuV/m	Limit dBuV/m	Margin dB	Detector	Comment
1 *	11590.4700	29.85	14.57	44.42	54.00	-9.58	AVG	
2	11590.6400	39.78	14.57	54.35	74.00	-19.65	Peak	

REMARKS:

- (1) Measurement Value = Reading Level + Correct Factor.
- (2) Margin Level = Measurement Value - Limit Value.

Orthogonal Axis	X
Test Mode	UNII-3_TX AC (VHT80) Mode 5775 MHz

Vertical

130 dBuV/m

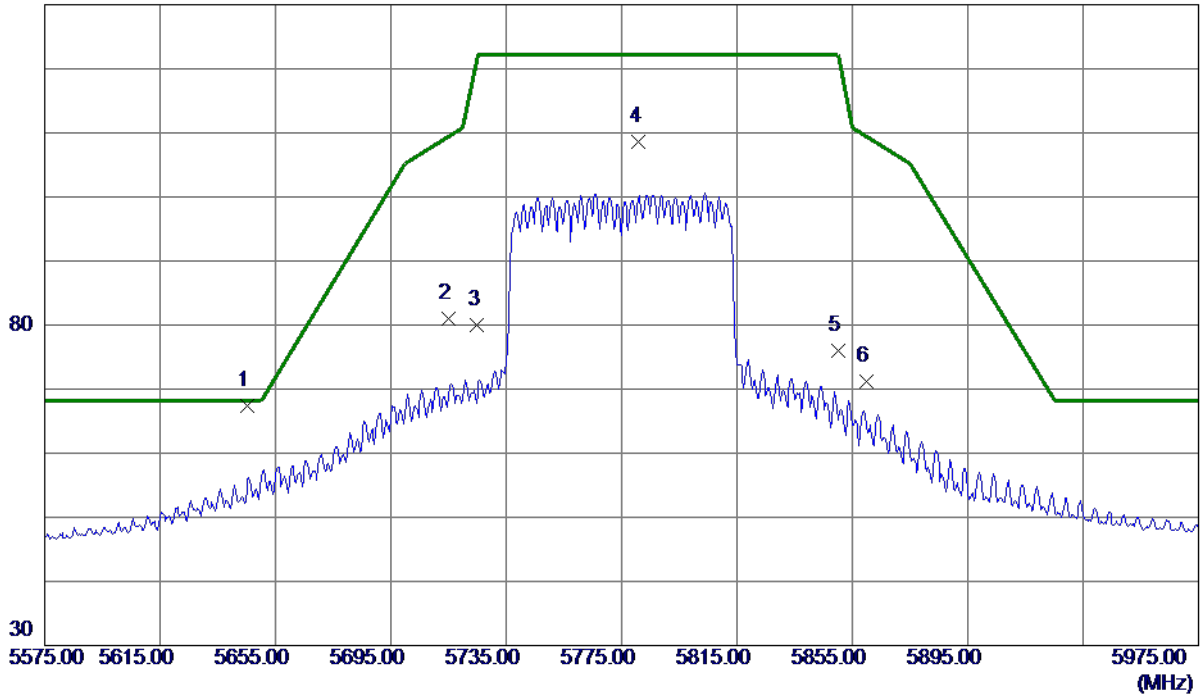

No.	Freq. MHz	Reading Level dBuV/m	Correct Factor dB	Measure ment dBuV/m	Limit dBuV/m	Margin dB	Detector	Comment
1 *	5645.4000	49.99	17.42	67.41	68.20	-0.79	Peak	
2	5715.0000	63.46	17.62	81.08	109.40	-28.32	Peak	
3	5725.0000	62.37	17.65	80.02	122.20	-42.18	Peak	
4	5781.0000	90.74	17.82	108.56	122.20	-13.64	Peak	No Limit
5	5850.0000	57.96	18.02	75.98	122.20	-46.22	Peak	
6	5860.0000	53.06	18.05	71.11	109.40	-38.29	Peak	

REMARKS:

- (1) Measurement Value = Reading Level + Correct Factor.
- (2) Margin Level = Measurement Value - Limit Value.

Orthogonal Axis	X
Test Mode	UNII-3_TX AC (VHT80) Mode 5775 MHz

Vertical

80 dBuV/m

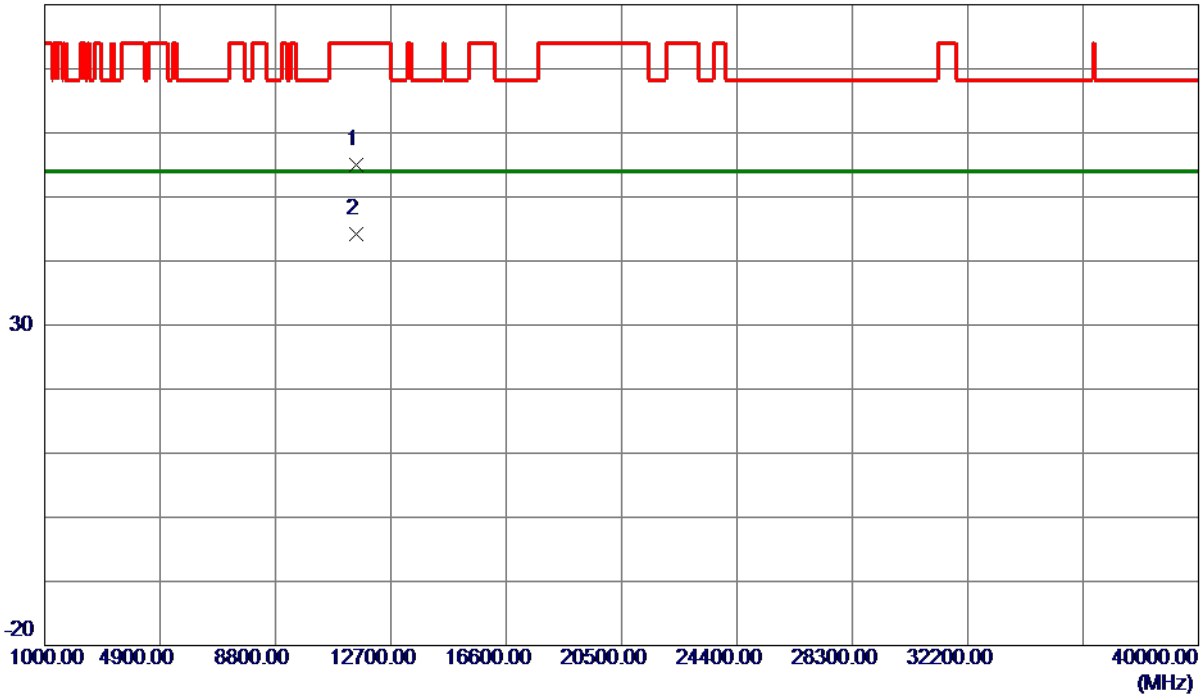

No.	Freq. MHz	Reading Level dBuV/m	Correct Factor dB	Measure ment dBuV/m	Limit dBuV/m	Margin dB	Detector	Comment
1	11550.0000	40.38	14.57	54.95	74.00	-19.05	Peak	
2 *	11550.4700	29.58	14.57	44.15	54.00	-9.85	AVG	

REMARKS:

- (1) Measurement Value = Reading Level + Correct Factor.
- (2) Margin Level = Measurement Value - Limit Value.

Orthogonal Axis	X
Test Mode	UNII-3_TX AC (VHT80) Mode 5775 MHz

Horizontal

130 dBuV/m

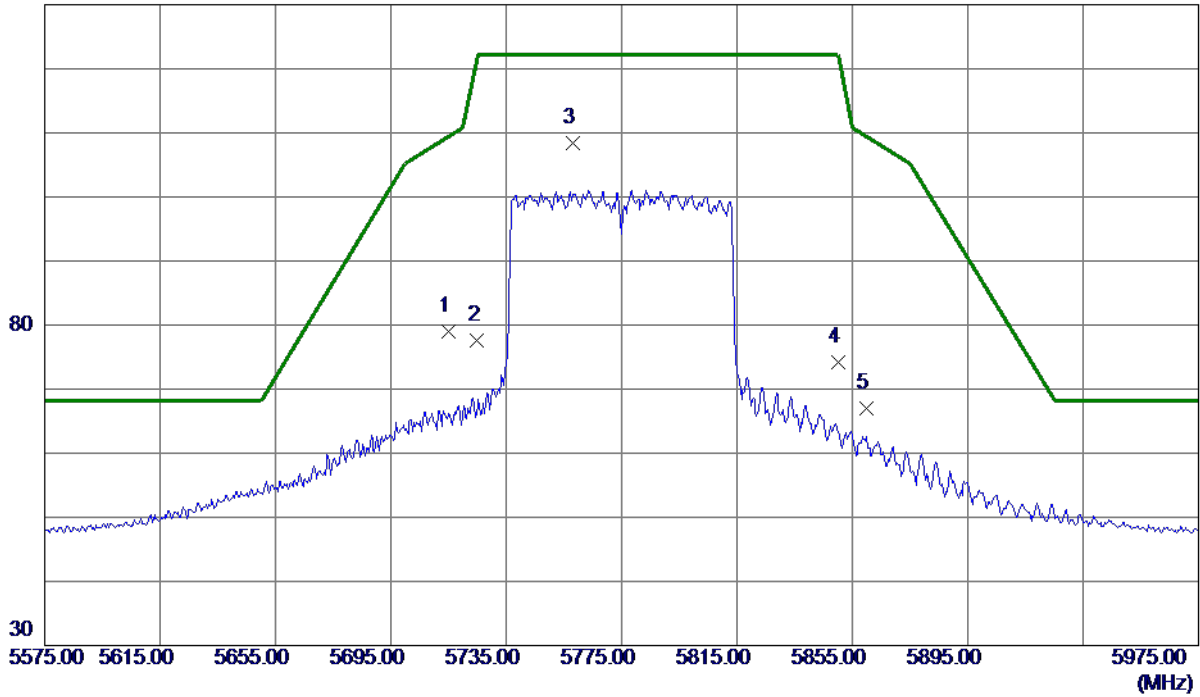

No.	Freq. MHz	Reading Level dBuV/m	Correct Factor dB	Measure ment dBuV/m	Limit dBuV/m	Margin dB	Detector	Comment
1	5715.0000	61.46	17.62	79.08	109.40	-30.32	Peak	
2	5725.0000	60.01	17.65	77.66	122.20	-44.54	Peak	
3 *	5758.2000	90.66	17.75	108.41	122.20	-13.79	Peak	No Limit
4	5850.0000	56.14	18.02	74.16	122.20	-48.04	Peak	
5	5860.0000	48.97	18.05	67.02	109.40	-42.38	Peak	

REMARKS:

- (1) Measurement Value = Reading Level + Correct Factor.
- (2) Margin Level = Measurement Value - Limit Value.

Orthogonal Axis	X
Test Mode	UNII-3_TX AC (VHT80) Mode 5775 MHz

Horizontal

80 dBuV/m

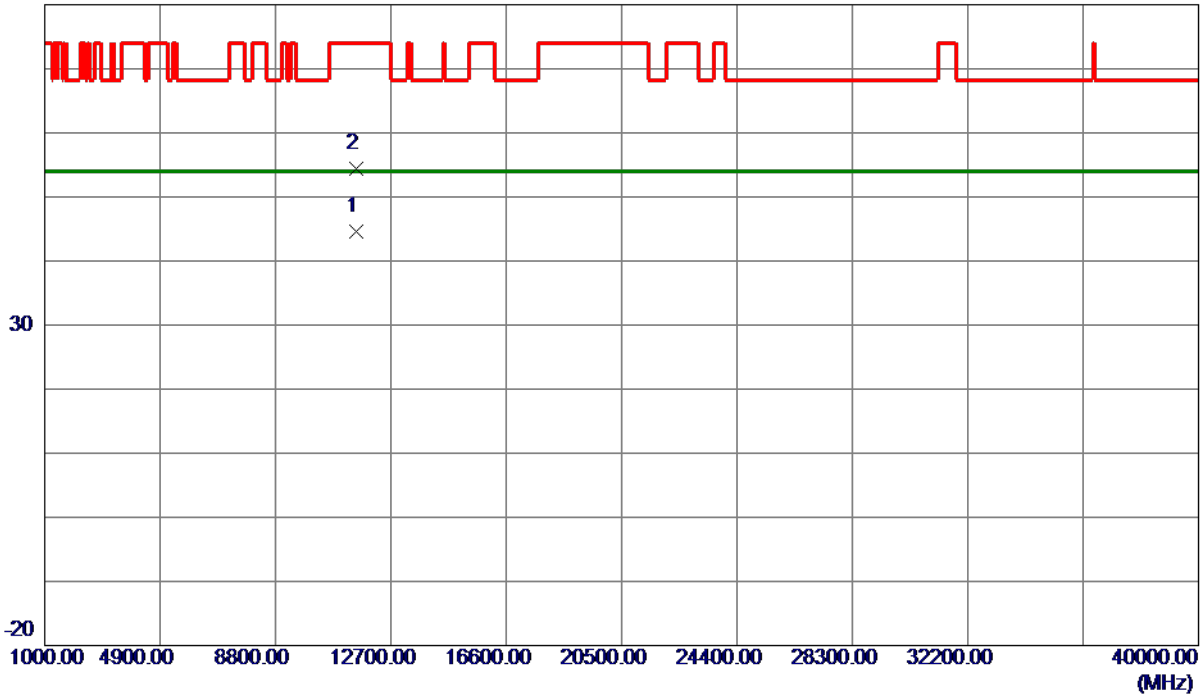

No.	Freq. MHz	Reading Level dBuV/m	Correct Factor dB	Measure ment dBuV/m	Limit dBuV/m	Margin dB	Detector	Comment
1 *	11550.2500	30.03	14.57	44.60	54.00	-9.40	AVG	
2	11550.4700	39.77	14.57	54.34	74.00	-19.66	Peak	

REMARKS:

- (1) Measurement Value = Reading Level + Correct Factor.
- (2) Margin Level = Measurement Value - Limit Value.

APPENDIX E - BANDWIDTH

Test Mode	UNII-1_TX A Mode
-----------	------------------

Channel	Frequency (MHz)	26 dB Bandwidth (MHz)	99 % Emission Bandwidth (MHz)
36	5180	21.85	17.40
40	5200	37.39	20.70
48	5240	37.19	19.90

CH36

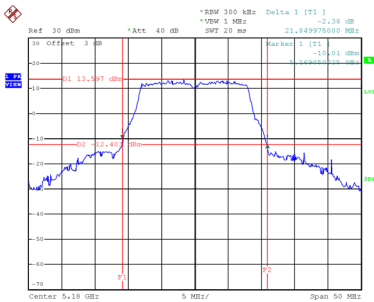

Date: 16.JUL.2020 11:53:59

CH40
26 dB Bandwidth

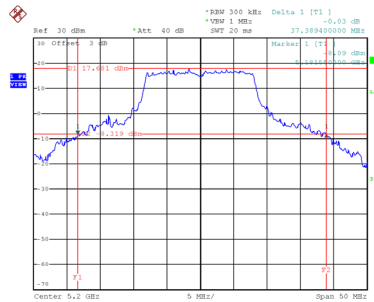

Date: 16.JUL.2020 11:56:25

CH48

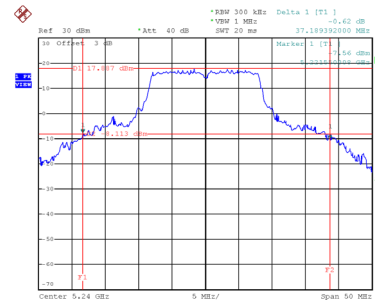

Date: 16.JUL.2020 13:43:28

99 % Emission Bandwidth

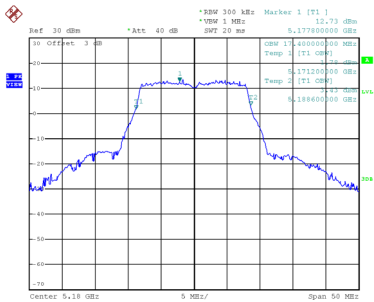

Date: 16.JUL.2020 11:53:39

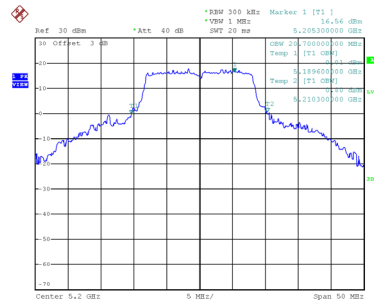

Date: 16.JUL.2020 11:56:13

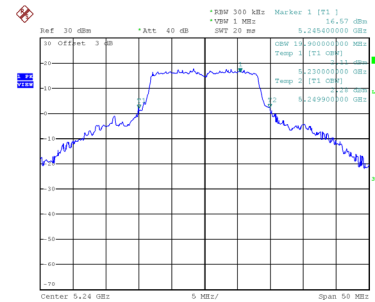

Date: 16.JUL.2020 13:43:15

Test Mode	UNII-2A_TX A Mode
-----------	-------------------

Channel	Frequency (MHz)	26 dB Bandwidth (MHz)	99 % Emission Bandwidth (MHz)
52	5260	21.99	17.40
60	5300	21.95	17.50
64	5320	21.85	17.50

CH52

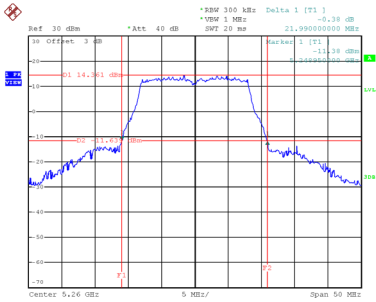

Date: 16.JUL.2020 13:46:12

CH60
26 dB Bandwidth

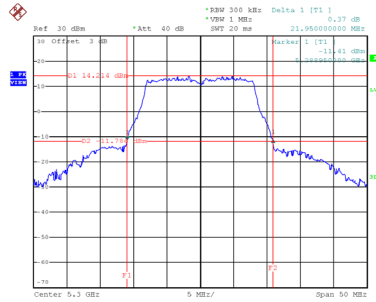

Date: 16.JUL.2020 13:48:14

CH64

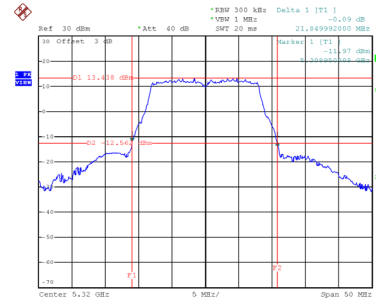

Date: 16.JUL.2020 13:49:19

99 % Emission Bandwidth

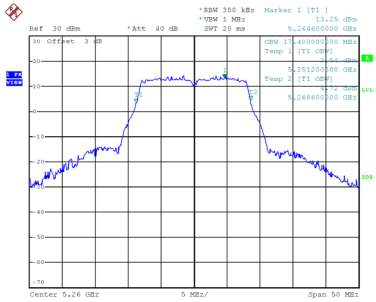

Date: 16.JUL.2020 13:45:52

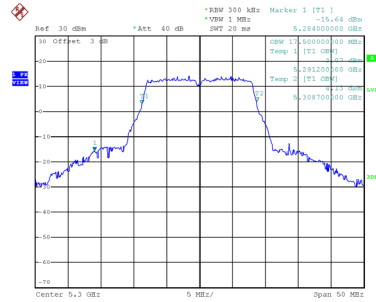

Date: 16.JUL.2020 13:47:54

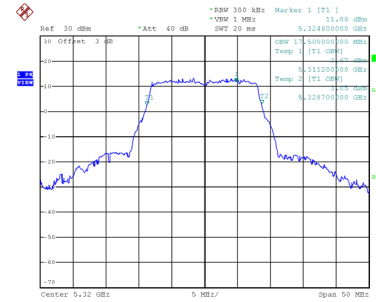

Date: 16.JUL.2020 13:49:00