

Important Information about the Sagemcom F@ST 2705 WS:

Operational working:

F@ST2705 WS must be used in a temperature controlled place. It is compliant to ETS 300 019-1-3 Class T

3.2 standard:

1. Temperature : 0°C to +45°C
2. Solar Radiation : 700w / m
3. Relative humidity : 5 to 85 % without condensation
4. No Airflow

Installation and Safe Usage Instructions:

1. Place the ADSL gateway on a flat surface.
2. Connect the manufacturer supplied AC to DC power adapter. The F@ST 2705 router requires the use of a 12VDC, 500 mA power adapter. Only use a manufacturer supplied and approved power adapter.
3. Connect the F@ST 2705 to the AC Mains in accordance with the installation instructions in this booklet, and the markings on the identification label (voltage, current, and frequency of electricity network).
4. Connect the Ethernet cable (provided) to one of the RJ45 ports on the ADSL Router labeled "LAN1", "LAN2", "LAN3", or "LAN4". Then connect the other end of the Ethernet Cable to the Ethernet port of a computer. Repeat as necessary for the other available Ethernet ports.
5. For a ADSL configuration, connect the provided DSL Cable to the port on the ADSL Router labeled "DSL". Connect the other end of the DSL Cable to a standard Phone Jack.

CAUTION: To reduce the risk of fire, always and only use a UL Listed or CSA Certified

Telecommunication Line Cord (DSL cable) with a minimum wire gauge of 26AWG (0.4 mm dia. minimum, or 0.129 mm² minimum) or larger (e.g., 24AWG).

Wall Mount Installation

This device can be mounted on a wall using the two mounting brackets on the bottom of the device, it is recommended to use two round or pan head screws (not included)

1. Install two screws horizontally apart on a wall using the measurement shown in Figure 1. The screws should protrude from the wall in order to fit the device between the head of the screw and the wall. If the screws are installed in drywall. Use hollow wall anchors to ensure that the unit does not pull away from the wall due to prolonged strain from the cable and power connectors.
2. Remove the device from the product package.
3. Mount the device on the wall.

Refer to Figures 1 and 2 for more details.

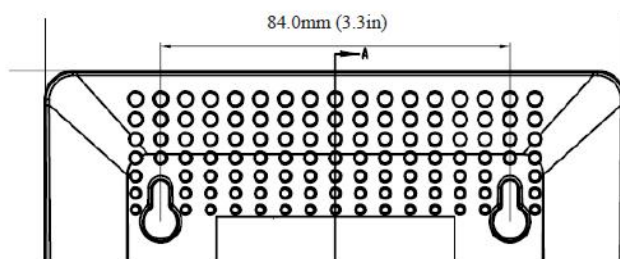

Figure 1: Distance (horizontal) Between Brackets for Screws

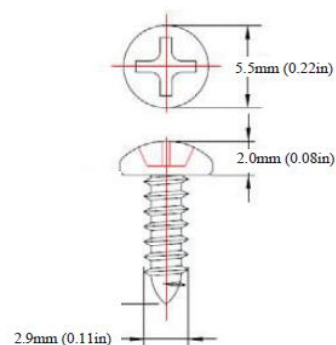

Figure 2: Recommended Screw Size

SAGEMCOM Safety and Certifications

When using this device, basic safety precautions should always be followed to reduce the risk of fire, electric shock, and injury to persons including the following:

1. Do not use this product near water and avoid contact with moisture. For example, do not use near a bathtub, wash bowl, kitchen sink, laundry tub, in a wet basement, or near a swimming pool. Care should be taken so that liquids are not spilled on this equipment.
2. This equipment is for indoor use only, do not place or install in an outdoor location.
3. The devices connected to the telephone interfaces must be kept indoor use only.
4. Never insert objects into the vents of this equipment as this can result in the risk of electrical shock or fire.
5. This equipment should only be operated from the type of power supply (Voltage and Current) indicated on the marking label.
6. Do not overload wall outlets or extension cords. Doing so can result in the risk of fire or electrical shock.
7. Avoid blocking any vent openings or exhaust exits on this equipment. Do not place equipment in a built-in installation such as a cabinet that may impede the flow of air through the ventilation openings.
8. The equipment should be situated away from heat sources such as radiators, heat registers, stoves, or other heat producing appliances and equipment.
9. Care should be taken to ensure that the power cord is routed, so it is not likely to be walked on or pinched by items placed upon or next to it.
10. Unplug this equipment before cleaning. Do not use liquid cleaners or aerosol cleaners. Use a damp cloth for cleaning only.
11. This equipment is not user serviceable and is to be serviced by qualified personnel only. Do not disassemble this equipment. If service is required, disconnect all power and phones lines from the equipment and consult qualified service personnel.
12. To disconnect this equipment from AC power, unplug the power supply from the AC wall socket.
13. Avoid using a telephone (other than a cordless type) during an electrical storm. There may be a remote risk of electric shock from lightning.
14. Do not use the telephone to report a gas leak in the vicinity of the leak.
15. Make sure the power socket to which you connect the power cord is easily accessible and as close as possible to the equipment so that the appliance can be unplugged quickly in case of a problem.

Save these Instructions!

FCC Statement

This equipment has been tested and found to comply with the limits for a Class B digital device, pursuant to part 15 of the FCC Rules. These limits are designed to provide reasonable protection against harmful interference in a residential installation. This equipment generates, uses and can radiate radio frequency energy and, if not installed and used in accordance with the instructions, may cause harmful interference to radio communications. However, there is no guarantee that interference will not occur in a particular installation. If this equipment does cause harmful interference to radio or television reception, which can be determined by turning the equipment off and on, the user is encouraged to try to correct the interference by one or more of the following measures:

- Reorient or relocate the receiving antenna.
- Increase the separation between the equipment and receiver.
- Connect the equipment into an outlet on a circuit different from that to which the receiver is connected.
- Consult the dealer or an experienced radio/TV technician for help.

FCC Radiation Exposure Statement

This device complies with FCC radiation exposure limits set forth for an uncontrolled environment and it also complies with Part 15 of the FCC RF Rules. This equipment must be installed and operated in accordance with provided instructions and the antenna(s) used for this transmitter must be installed to provide a separation distance of at least 20 cm from all persons and must not be co-located or operating in conjunction with any other antenna or transmitter. End-users and installers must be provide with antenna installation instructions and consider removing the no-collocation statement.

This device complies with Part 15 of the FCC Rules. Operation is subject to the following two conditions:

- (1) this device may not cause harmful interference, and
- (2) this device must accept any interference received, including interference that may cause undesired operation.

Caution!

Any changes or modifications not expressly approved by the party responsible for compliance could void the user's authority to operate the equipment.

FCC - PART 68

This equipment complies with Part 68 of the FCC rules and the requirements adopted by the ACTA. On the bottom of this equipment is a label that contains, among other information, a product identifier in the format US:RI6DL01AFast2705. If requested, this number must be provided to the telephone company.

This equipment uses the following USOC jacks: RJ-11, RJ-45, Microfilter, Mains Adapters.

REN (RINGER EQUIVALENT NUMBERS) STATEMENT

Notice: The Ringer Equivalence Number (REN:0.1A) assigned to each terminal device provides an indication of the maximum number of terminals allowed to be connected to a telephone interface. The termination on an interface may consist of any combination of devices subject only to the requirement that the sum of the Ringer Equivalence Numbers of all the devices does not exceed 5.

SAGEMCOM Safety and Certifications

ATTACHMENT LIMITATIONS STATEMENT

Notice: This equipment meets telecommunications network protective, operational and safety requirements as prescribed in the appropriate Terminal Equipment Technical Requirements document(s). This is confirmed by marking the equipment with the Industry Canada certification number. The Department does not guarantee the equipment will operate to the user's satisfaction.

Before installing this equipment, users should ensure that it is permissible to be connected to the facilities of the local telecommunications company. The equipment must also be installed using an acceptable method of connection. The customer should be aware that compliance with the above conditions may not prevent degradation of service in some situations.

Repairs to certified equipment should be coordinated by a representative designated by the supplier. Any repairs or alterations made by the user to this equipment, or equipment malfunctions, may give the telecommunications company cause to request the user to disconnect the equipment.

Users should ensure for their own protection that the electrical ground connections of the power utility, telephone lines and internal metallic water pipe system, if present, are connected together.

This precaution may be particularly important in rural areas. Caution: Users should not attempt to make such connections themselves, but should contact the appropriate electric inspection authority, or electrician, as appropriate.

This equipment has a Universal Service Order Code (USOC) of RJ11C, a Facility Interface Code (FIC) of METALLIC, and the Service Order Code (SOC) is N/A. The Telephone Company may request this information when ordering service for this equipment. A plug and jack used to connect this equipment to the premises wiring and telephone network must comply with the applicable FCC Part 68 rules and requirements adopted by the ACTA. A compliant telephone cord and modular plug is provided with this product. It is designed to be connected to a compatible modular jack that is also compliant.

The REN is used to determine the number of devices that may be connected to a telephone line. Excessive RENs on a telephone line may result in the devices not ringing in response to an incoming call. In most but not all areas, the sum of RENs should not exceed five (5.0). To be certain of the number of devices that may be connected to a line, as determined by the total RENs, company. For products approved after July 23, 2001, the REN for this product is part of the product contact the local telephone company. For products approved after July 23, 2001, the REN for this product is part of the product identifier that has the format US:AAAEQ##TXXXX. The digits represented by ## are the REN without a decimal point (e.g., 03 is a REN of 0.3). For earlier products, the REN is separately shown on the label.

If this equipment causes harm to the telephone network, the telephone company will notify you in advance that temporary discontinuance of service may be required. But if advance notice isn't practical, the Telephone Company will notify the customer as soon as possible. Also, you will be advised of your right to file a complaint with the FCC if you believe it is necessary.

The Telephone Company may make changes to its facilities, equipment, operations or procedures that could affect the operation of the equipment. If this happens the Telephone Company will provide advance notice so you can make the necessary modifications to maintain uninterrupted service. This equipment is not user serviceable. If trouble is experienced with this equipment, for repair or warranty information, please contact Sagemcom at:

Via USA Telephone: +1 (972) 674-4100	Or Via Mail: Sagemcom USA LLC 14651 N. Dallas Parkway Suite 900 Dallas, TX 75254
--------------------------------------	--

SAGEMCOM Safety and Certifications

If the equipment is causing harm to the telephone network, the Telephone Company may request that you disconnect the equipment until the problem is resolved.

Connection to party line service is subject to state tariffs. (Contact the state public utility commission, public service commission or corporation commission for information.)

If your home has specially wired alarm equipment connected to the telephone line, ensure the installation of this equipment does not disable your alarm equipment. If you have questions about what will disable alarm equipment, consult your telephone company or a qualified installer.

This equipment connects to the telephone network that can be vulnerable to electrical surges as a result of lightning strikes and other events. Such events can be very destructive to equipment connected to both the telephone network and to AC power sources. It is strongly recommended that a surge arrester be used to connect this equipment to AC power in order to reduce the possibility of damage resulting from such events.

FCC Radiation Exposure Statement

This equipment complies with "FCC1.1310 for radiation exposure limits set forth for an uncontrolled environment". This transmitter must not be co-located or operating in conjunction with any other antenna or transmitter.

This device produces radio frequency energy in the 2.4 GHz spectrum. The antenna should be positioned to keep a minimum distance of 20cm (0.65ft) from the radiating element to any nearby person.