

ZB2530UPA-A Module Datasheet v1.0

Introduction

The CC2530 is a system-on-chip (SoC) solution for IEEE 802.15.4, Zigbee, and RF4CE applications. The CC2530 combines the excellent performance of a leading RF transceiver with an industry-standard enhanced 8051 MCU, in-system programmable Flash memory, 8-KB RAM, and many other powerful features.

This chip enables industrial grade applications by offering state-of-the-art selectivity and co-existence, excellent link budget, and low-voltage operation.

The CC2591 is a range extender for 2.4GHz RF transceivers, transmitters, and SoC products from Texas Instruments. The CC2591 increases the RF link budget by providing a Power Amplifier (PA) for higher output power and a Low Noise Amplifier (LNA) for improved receiver sensitivity. The CC2591 contains RF switches, RF matching, and an on-chip

balun for a seamless interface with the CC2530. This allows for a simple design of high performance wireless applications.

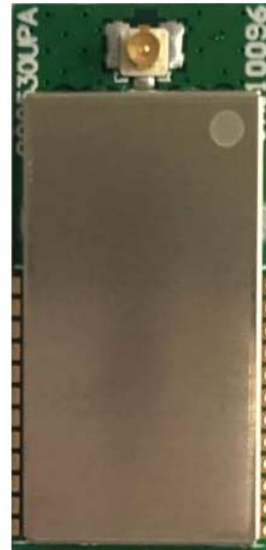

Characteristics

Recommended Operating Conditions

Parameter	Min	Max	Unit
Operating Frequency	2405	2480	MHz
Operating Supply Voltage	2.0	3.6	V
Operating Temperature	-40	125	°C

Radio Characteristics

Parameter	Specifications
Current Consumption	TX: 166mA RX: 24~27mA
RX Sensitivity HGM	-98.8dBm
RX Sensitivity LGM	-90.4dBm

Functional Block Diagram

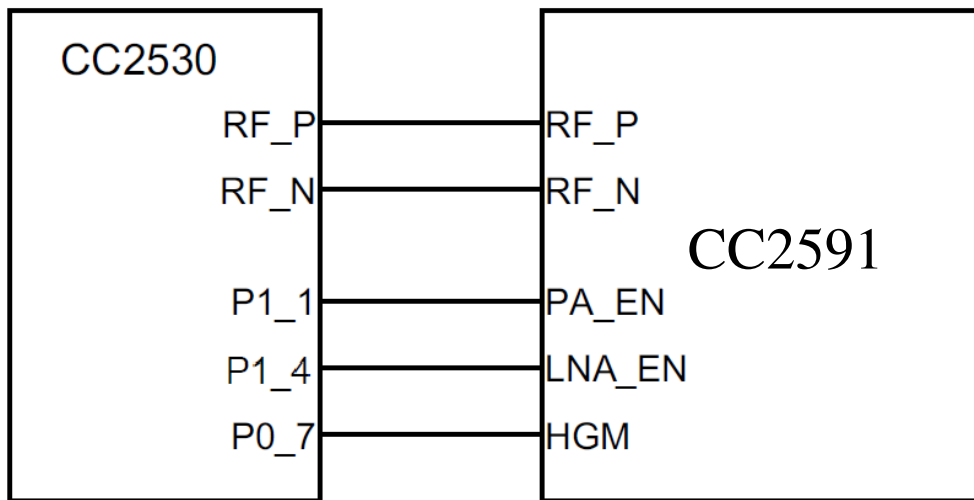

Control Logic for connecting the CC2591 to a CC2530 Device

There are three digital control pins(PA_EN, LNA_EN and HGM) on the CC2591 that control the state of the chip. The following table shows the control logic when connecting the CC2591 to a CC2530 device.

PA_EN	LAN_EN	HGM	Mode of Operation
0	0	X	Power Down
0	1	0	RX Low Gain Mode
0	1	1	RX High Gain Mode
1	0	X	TX

Terminal Description

Pad Number	Name	Pin Type	Description
1	P2_2	Digital I/O	Port 2.2
2	P2_1	Digital I/O	Port 2.1
3	P2_0	Digital I/O	Port 2.0
4	P1_7	Digital I/O	Port 1.7
5	P1_6	Digital I/O	Port 1.6
6	P1_5	Digital I/O	Port 1.5
7	P1_4	Digital I/O	Port 1.4

8	P1_3	Digital I/O	Port 1.3
9	P1_2	Digital I/O	Port 1.2
10	P1_1	Digital I/O	Port 1.1, 20mA drive capability
11	P1_0	Digital I/O	Port 1.0, 20mA drive capability
12	P0_7	Digital I/O	Port 0.7
13	GND	Ground Pin	Connect to GND
14	GND	Ground Pin	Connect to GND
15	P0_6	Digital I/O	Port 0.6
16	P0_5	Digital I/O	Port 0.5
17	P0_4	Digital I/O	Port 0.4
18	P0_3	Digital I/O	Port 0.3
19	P0_2	Digital I/O	Port 0.2
20	P0_1	Digital I/O	Port 0.1
21	P0_0	Digital I/O	Port 0.0
22	RESET_N	Digital Input	Reset, active-low
23	VDD	Power	2V to 3.6V main chip supply
24	VDD	Power	2V to 3.6V main chip supply

Mechanical Drawing

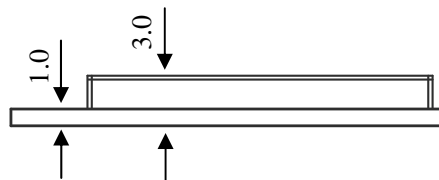
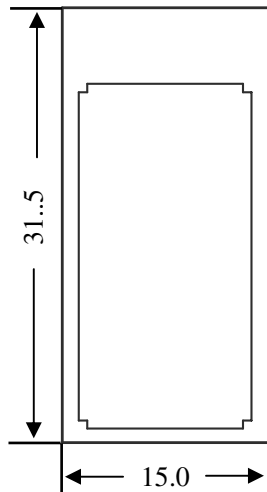

Unit: mm

Tolerance: ± 0.2 mm

IMPORTANT NOTE:

This module has been granted as Single modular approval.

The manufacturer is responsible to follow the instruction hereafter for the FCC compliance requirement of the end product. Under such configuration, the FCC radiation exposure limits set forth for an population/uncontrolled environment can be satisfied. The device with a Monopole antenna gain with maximum gain 3.5dBi.

This device may only operate using an antenna of a type and maximum (or lesser) gain approved by Beijing Jia An Electronics Thechnology Co,.Ltd, Antenna types difference or having a gain greater than the maximum gain indicated for that type are strictly prohibited for use with this transmitter.

Warning:

Any Changes or modifications not expressly approved by the party responsible for compliance could void the user's authority to operate the equipment.

This device complies with part 15 of the FCC Rules. Operation is subject to the following two conditions: (1) This device may not cause harmful interference, and (2) this device must accept any interference received, including interference that may cause undesired operation.

Note: This equipment has been tested and found to comply with the limits for a Class B digital device, pursuant to part 15 of the FCC Rules. These limits are designed to provide

reasonable protection against harmful interference in a residential installation. This equipment generates, uses and can radiate radio frequency energy and, if not installed and used in accordance with the instructions, may cause harmful interference to radio communications. However, there is no guarantee that interference will not occur in a particular installation. If this equipment does cause harmful interference to radio or television reception, which can be determined by turning the equipment off and on, the user is encouraged to try to correct the interference by one or more of the following measures:

—Reorient or relocate the receiving antenna.

—Increase the separation between the equipment and receiver.

—Connect the equipment into an outlet on a circuit different from that to which the receiver is connected.

—Consult the dealer or an experienced radio/TV technician for help.

FCC Radiation Exposure Statement:

This equipment complies with FCC radiation exposure limits set forth for an uncontrolled environment .

This transmitter must not be co-located or operating in conjunction with any other antenna or transmitter.

This equipment should be installed and operated with minimum distance 20cm between the radiator& your body.

This radio transmitter (identify the device by certification number) has been approved by FCC to operate with the antenna types with the maximum permissible gain indicated.

The final end product must be labeled in a visible area with the following: Contains Transmitter

Module FCC ID:VVJ-ZB2530UPA-A