



**TEST REPORT
FROM
RFI GLOBAL SERVICES LTD**

Test of: Dell Latitude E4200 Notebook PC

To: OET Bulletin 65 Supplement C: (2001-01)

Test Report Serial No:
RFI/SAR2/RP75978JD11A

This Test Report Is Issued Under The Authority Of Scott D'Adamo, Group Service Manager Wireless and Cellular:		
Checked By: Scott D'Adamo 	Report Copy No: PDF01	
Issue Date: 28 October 2009	Test Dates: 17 September 2009 to 01 October 2009	

This report is issued in Adobe Acrobat portable document format (PDF). It is only a valid copy of the report if it is being viewed in PDF format with the following security options not allowed: Changing the document, Selecting text and graphics, Adding or changing notes and form fields.

This report may be copied in full. The results in this report apply only to the sample(s) tested.

Test of: Dell Latitude E4200 Notebook PC

To: OET Bulletin 65 Supplement C: (2001-01)

This page has been left intentionally blank.

Test of: Dell Latitude E4200 Notebook PC

To: OET Bulletin 65 Supplement C: (2001-01)

Table of Contents

1. Customer Information	4
2. Equipment Under Test (EUT)	5
3. Test Specification, Methods and Procedures	8
4. Deviations from the Test Specification	9
5. Operation and Configuration of the EUT during Testing	10
6. Summary of Test Results.....	12
7. Measurements, Examinations and Derived Results.....	13
8. Measurement Uncertainty.....	26
Appendix 1. Test Equipment Used.....	30
Appendix 2. Measurement Methods	33
Appendix 3. SAR Distribution Scans	35
Appendix 4. Photographs	58
Appendix 5. Validation of System	68
Appendix 6. Simulated Tissues.....	75
Appendix 7. DASY4 System Details.....	76

Test of: Dell Latitude E4200 Notebook PC

To: OET Bulletin 65 Supplement C: (2001-01)

1. Customer Information

Company Name:	Dell Inc.
Address:	One Dell Way Round Rock TX 78682 USA

Test of: Dell Latitude E4200 Notebook PC

To: OET Bulletin 65 Supplement C: (2001-01)

2. Equipment Under Test (EUT)

2.1. Identification of Equipment Under Test (EUT)

Description:	Notebook PC
Brand Name:	Dell
Model Name or Number:	Latitude E4200
Serial Number:	None Stated
Ericsson F3607gw SKU-850 Module IMEI Number:	004401700230929
Ericsson F3607gw SKU-900 Module IMEI Number:	004401700232164
Hardware Version Number:	A00
Software Version Number:	Rev.A
Hardware Revision of GSM Module:	R1
Software Revision of GSM Module:	R1G05
FCC ID Number F3607gw SKU-850:	VV7-MBMF3607GW1-D
FCC ID Number F3607gw SKU-900:	VV7-MBMF3607GW2-D
Country of Manufacture:	China
Date of Receipt:	07 September 2009

2.2. Description of EUT

The equipment under test is a Dell Latitude E4200 Notebook PC fitted with an Ericsson mobile broadband modules F3607gw (SKU-900 and SKU850), alternate model name Dell Wireless 5540 HSPA Mobile Broadband Mini-card.

2.3. Modifications Incorporated in the EUT

There were no modifications incorporated in the EUT during testing.

2.4. Accessories

The following accessories were supplied with the EUT during testing:

Description:	Battery
Brand Name:	Dell
Model Name or Number:	Y082C
Serial Number:	None Stated
Cable Length and Type:	Not Applicable
Country of Manufacture:	Japan
Connected to Port	7 Pin Array Contact Point

Test of: Dell Latitude E4200 Notebook PC

To: OET Bulletin 65 Supplement C: (2001-01)

2.5. Support Equipment

The following support equipment was used to exercise the EUT during testing:

Description:	Wireless Communication Test Set
Brand Name:	Agilent
Model Name or Number:	8960 Series 10
Serial Number:	GB46311280
Cable Length and Type:	1.5m Utiflex Cable
Connected to Port:	RF (Input/Output) Air Link

Test of: Dell Latitude E4200 Notebook PC

To: OET Bulletin 65 Supplement C: (2001-01)

2.6. Additional Information Related to Testing

Equipment Category	GPRS850/1900; EGPRS850/1900; UMTS FDDII/FDDV HSPA, <i>Bluetooth</i>		
Type of Unit	Portable Transceiver		
Intended Operating Environment:	Within 2G GSM, 3G UMTS and <i>Bluetooth</i> coverage		
Transmitter Maximum Output Power Characteristics:	GPRS/EGPRS850	33dBm	
	GPRS/EGPRS1900	30dBm	
	UMTS/HSPA FDD V	24dBm	
	UMTS/HSPA FDD II	24dBm	
	Bluetooth	6dBm	
Transmitter Frequency Range:	GPRS/EGPRS850	824 to 849 MHz	
	GPRS/EGPRS1900	1850 to 1910 MHz	
	UMTS/HSPA FDD V	826 to 847 MHz	
	UMTS/HSPA FDD II	1880 to 1908 MHz	
Transmitter Frequency Allocation of EUT When Under Test:	Channel Number	Channel Description	Frequency (MHz)
	128	Low	824.2
	189	Middle	836.4
	251	High	848.8
	512	Low	1850.2
	660	Middle	1879.8
	810	High	1909.8
	9262	Low	1852.4
	9400	Middle	1880
	9538	High	1907.6
	4132	Low	826.4
	4183	Middle	836.6
	4233	High	846.6
Modulation(s):	GMSK:217Hz, QPSK:0Hz		
Modulation Scheme (Crest Factor):	GMSK(GPRS/EGPRS):4, QPSK(UMTS/HSPA):1		
Antenna Type:	Integral fixed onto the screen surroundings.		
Antenna Length:	Internal antennas of unknown lengths		
Number of Antenna Positions:	1 Fixed		
Power Supply Requirement:	14.8V dc		
Battery Type(s):	Li-ion		

Test of: Dell Latitude E4200 Notebook PC

To: OET Bulletin 65 Supplement C: (2001-01)

3. Test Specification, Methods and Procedures

3.1. Test Specification

Reference:	OET Bulletin 65 Supplement C: (2001-01)
Title:	Evaluating Compliance with FCC Guidelines for Human Exposure to Radio Frequency Electromagnetic Fields.
Purpose of Test:	To determine whether the equipment met the basic restrictions as defined in OET Bulletin 65 Supplement C: (2001-01) using the SAR averaging method as described in the test specification above.

3.2. Methods and Procedures Reference Documentation

The methods and procedures used were as detailed in:

Federal Communications Commission, "Evaluating compliance with FCC Guidelines for human exposure to radio frequency electromagnetic fields", OET Bulletin 65 Supplement C, FCC, Washington, D.C, 20554, 2001.

Thomas Schmid, Oliver Egger and Neils Kuster, "Automated E-field scanning system for dosimetric assessments", IEEE Transaction on microwave theory and techniques, Vol. 44, pp. 105-113, January 1996.

Neils Kuster, Ralph Kastle and Thomas Schmid, "Dosimetric evaluation of mobile communications equipment with know precision", IEICE Transactions of communications, Vol. E80-B, No.5, pp. 645-652, May 1997.

KDB 447498 D01 Mobile Portable RF Exposure v03.

KDB 616217 D01 SAR for Notebook PC v01.

KDB 941225 D01 SAR 3G Test Procedures v02

KDB 941225 D03 SAR Test Reduction GSM/GPRS/EDGE vo1

KDB 450824 D01 SAR Prob Cal and Ver Meas v01r01

3GPP TS 34.121

3.3. Definition of Measurement Equipment

The measurement equipment used complied with the requirements of the standards referenced in the methods & procedures section above. Appendix 1 contains a list of the test equipment used.

Test of: Dell Latitude E4200 Notebook PC

To: OET Bulletin 65 Supplement C: (2001-01)

4. Deviations from the Test Specification

Test was performed as per "FCC KDB 447498 D01 Mobile Portable RF Exposure v03" and according to the body-worn procedures in consideration with FCC KDB 616217, FCC KDB 941225 SAR 3G devices v02, KDB 941225 D03 SAR Test Reduction GSM/GPRS/EDGE vo1 and KDB 450824 test Procedures and OET Bulletin 65 Supplement C 01-01 specific FCC test procedures. Testing followed the letter of TS-34.121 5.2B.4.2.

Prior to commencement of SAR testing the FCC was contacted to request permission to test the Notebook PC as the WLAN antenna was < 5cm away from the user. Permission was granted with the condition that the sum of the 1-g SAR does not exceed 1.6 w/kg SAR limit and the following KDB correspondence number was acquired 804534. This Evaluation SAR evaluation was performed on only the WWAN module as the WLAN module has already been SAR tested.

SAR test for WWAN was performed using Ericsson F3607gw SKU-850 module, the worst case test configuration from the SKU-850 module was used to performed test on the SKU-900 module for frequencies that both modules supported. The additional frequency band that the SKU-900 module supported UMTS FDD VIII was also evaluated.

Test of: Dell Latitude E4200 Notebook PC

To: OET Bulletin 65 Supplement C: (2001-01)

5. Operation and Configuration of the EUT during Testing

5.1. Operating Modes

The EUT was tested in the following operating mode(s) unless otherwise stated:

- Test was performed on a Dell Latitude E4200 Notebook PC with Windows XP Home Edition Version 2002 SP3 operating system installed.
 - Test was performed with Bluetooth disabled as the output power was $< 60/f(\text{GHz})$ and antenna to antenna distance $> 5\text{cm}$.
 - Throughout the duration of testing the HSPA channels remained active with the required E-TFCI and AG index values being maintained. This was verified by observing the HSUPA and HSDP uplink and downlink throughput parameters using an Agilent 8960 series 10 wireless communications test set which supports HSPA release 6.
 - Simultaneous transmission was not evaluation as the sum of the 1-g SAR was $< 1.6\text{ W/kg}$ and $r > 5\text{ cm}$.
 - UMTS FDD - RMC 12.2kbps with Test loop mode 1 and TPC bits configured to All "1's"
 - UMTS FDD - RMC 12.2kbps with Test loop mode 1 and TPC bits configured to All "1's" with HSDPA enabled.
 - UMTS FDD - FRC configured to HS-DPCCH Sub-test 1 and H-Set 1 and QPSK settings with HSPA enabled.
 - EGPRS850 / EGPRS900 / EGPRS1800 / EGPRS1900 Data allocated mode using Agilent 8960 configured to allow WWAN module to transmit at maximum output power.
 - GPRS850 / GPRS900 / GPRS1800 / GPRS1900 Data allocated mode using Agilent 8960 configured to allow WWAN module to transmit at maximum output power.
-

Test of: Dell Latitude E4200 Notebook PC

To: OET Bulletin 65 Supplement C: (2001-01)

5.2. Configuration and Peripherals

The EUT was tested in the following configuration(s) unless otherwise stated:

- Throughout the duration of testing the HSPA channels remained active with the required E-TFCI and AG index values being maintained. This was verified by observing the HSUPA and HSDP uplink and downlink throughput parameters using an Agilent 8960 series 10 wireless communications test set which supports HSPA release 6. The test parameters were in accordance with power table settings in KDB 941225 for HSDPA Release 5 and HSPA Release 6 and TS 34.121 Table C.10.1 – C.10.4.
- The power measurements at maximum output power is verified on the High, Middle and Low channels according to Release 6 procedures in section 5.2 of 3GPP TS 34.121 using the appropriate RMC, FRC and E-DCH configurations. Prior to commencement of SAR testing the module power levels were measured in both HSPA and 3G RMC 12.2kbps modes and compared to ensure the correct mode of operation had been established.
- EUT was tested in the Body-Worn configuration only, with the bottom of the Notebook PC in direct contact against the flat phantom (0mm separation) and display open at 90 degrees to the keypad.
- Standalone Battery Operated

Body Configuration

- a) The EUT was placed in a normal operating position where the centre of EUT was aligned with the centre reference point on the flat section of the 'OVAL 3mm' phantom.
 - b) With the EUT touching the phantom at an imaginary centre line. The EUT was aligned with a marked plane (X and Y axis) consisting of two lines.
 - c) For the touch-safe position the handset was gradually moved towards the flat section of the 'Oval 3mm' phantom until any point of the EUT touched the phantom.
 - d) For position(s) greater than 0mm separation the EUT was positioned as per the touch-safe position, and then the vertical height was decreased/adjusted as required.
 - e) SAR measurements were evaluated at maximum power and the unit was operated for an appropriate period prior to the evaluation in order to minimise the drift.
 - f) The device was keyed to operate continuously in the transmit mode for the duration of the test.
 - g) The location of the maximum spatial SAR distribution (hot spot) was determined relative to the handset and its antenna.
 - h) The EUT was transmitting at predefined power stated in section 5.1 throughout the duration of the test.
-

Test of: Dell Latitude E4200 Notebook PC

To: OET Bulletin 65 Supplement C: (2001-01)

6. Summary of Test Results

Test Name	Specification Reference	Results
Specific Absorption Rate-GPRS850 Body Configuration 1g	OET Bulletin 65 Supplement C: (2001-01)	Complied
Specific Absorption Rate-EGPRS850 Body Configuration 1g	OET Bulletin 65 Supplement C: (2001-01)	Complied
Specific Absorption Rate-UMTS Body Configuration 1g	OET Bulletin 65 Supplement C: (2001-01)	Complied
Specific Absorption Rate-UMTS Body Configuration 1g	OET Bulletin 65 Supplement C: (2001-01)	Complied
Specific Absorption Rate-GPRS1900 Body Configuration 1g	OET Bulletin 65 Supplement C: (2001-01)	Complied
Specific Absorption Rate-EGPRS1900 Body Configuration 1g	OET Bulletin 65 Supplement C: (2001-01)	Complied
Specific Absorption Rate-UMTS Body Configuration 1g	OET Bulletin 65 Supplement C: (2001-01)	Complied
Specific Absorption Rate-UMTS Body Configuration 1g	OET Bulletin 65 Supplement C: (2001-01)	Complied

6.1. Location of Tests

All the measurements described in this report were performed at the premises of RFI Global Services Ltd, Pavilion A, Ashwood Park, Ashwood Way, Basingstoke, Hampshire, RG23 8BG United Kingdom

Test of: Dell Latitude E4200 Notebook PC

To: OET Bulletin 65 Supplement C: (2001-01)

7. Measurements, Examinations and Derived Results

7.1. General Comments

This section contains test results only.

Measurement uncertainties are evaluated in accordance with current best practice. Our reported expanded uncertainties are based on standard uncertainties, which are multiplied by an appropriate coverage factor to provide a statistical confidence level of approximately 95%. Please refer to section 8 for details of measurement uncertainties.

Test of: Dell Latitude E4200 Notebook PC

To: OET Bulletin 65 Supplement C: (2001-01)

7.2. Test Results**7.2.1. Specific Absorption Rate - GPRS850 Body Configuration 1g****Test Summary:**

Tissue Volume:	1g
Maximum Level (W/kg):	0.137

Environmental Conditions:

Temperature Variation in Lab (°C):	25.0 to 25.0
Temperature Variation in Liquid (°C):	23.2 to 23.2

Results:

EUT Position	Phantom Configuration	Channel Number	Level (W/kg)	Limit (W/kg)	Margin (W/kg)	Note(s)	Result
Base of EUT Facing Phantom With Display 90° to Keyboard	Flat (OVAL 3mm)	189	0.053	1.600	1.547	1, 2, 3	Complied
Base of EUT Facing Phantom With Display 90° to Keyboard	Flat (OVAL 3mm)	189	0.137	1.600	1.463	1, 2, 4	Complied

Note(s):

- EUT was tested in the Body-Worn configuration with the bottom of the Notebook in direct contact against the flat phantom (0mm separation) and display open at 90 degrees to the keypad.
- SAR test was performed in the middle channel only as the measured levels were <50% of the SAR limit as stated in the FCC Public Notice DA 02-1438 by the SCC-34/SC-2.
- WWAN SKU-850 module
- WWAN SKU-900 Module

Test of: Dell Latitude E4200 Notebook PC

To: OET Bulletin 65 Supplement C: (2001-01)

7.2.2. Specific Absorption Rate - EGPRS850 Body Configuration 1g**Test Summary:**

Tissue Volume:	1g
Maximum Level (W/kg):	0.038

Environmental Conditions:

Temperature Variation in Lab (°C):	25.0 to 25.0
Temperature Variation in Liquid (°C):	23.2 to 23.2

Results:

EUT Position	Phantom Configuration	Channel Number	Level (W/kg)	Limit (W/kg)	Margin (W/kg)	Note(s)	Result
Base of EUT Facing Phantom With Display 90° to Keyboard	Flat (OVAL 3mm)	189	0.038	1.600	1.562	1, 2, 3	Complied

Note(s):

1. EUT was tested in the Body-Worn configuration with the bottom of the Notebook in direct contact against the flat phantom (0mm separation) and display open at 90 degrees to the keypad.
2. SAR test was performed in the middle channel only as the measured levels were <50% of the SAR limit as stated in the FCC Public Notice DA 02-1438 by the SCC-34/SC-2.
3. WWAN SKU-850 module

Test of: Dell Latitude E4200 Notebook PC

To: OET Bulletin 65 Supplement C: (2001-01)

7.2.3. Specific Absorption Rate - UMTS FDD V Body Configuration 1g

Test Summary:

Tissue Volume:	1g
Maximum Level (W/kg):	0.021

Environmental Conditions:

Temperature Variation in Lab (°C):	25.0 to 25.0
Temperature Variation in Liquid (°C):	23.2 to 23.2

Results:

EUT Position	Phantom Configuration	Channel Number	Level (W/kg)	Limit (W/kg)	Margin (W/kg)	Note(s)	Result
Base of EUT Facing Phantom With Display 90° to Keyboard	Flat (OVAL 3mm)	4183	0.021	1.600	1.580	1, 2, 3, 4	Complied

Note(s):

1. RMC 12.2kbps with Test loop mode 1 and TPC bits configured to All "1's"
2. EUT was tested in the Body-Worn configuration with the bottom of the Notebook in direct contact against the flat phantom (0mm separation) and display open at 90 degrees to the keypad.
3. SAR test was performed in the middle channel only as the measured levels were <50% of the SAR limit.
4. WWAN SKU-850 module

Test of: Dell Latitude E4200 Notebook PC

To: OET Bulletin 65 Supplement C: (2001-01)

7.2.4. Specific Absorption Rate - UMTS FDD V + HSPA Body Configuration 1g**Test Summary:**

Tissue Volume:	1g
Maximum Level (W/kg):	0.019

Environmental Conditions:

Temperature Variation in Lab (°C):	25.0 to 25.0
Temperature Variation in Liquid (°C):	23.2 to 23.2

Results:

EUT Position	Phantom Configuration	Channel Number	Level (W/kg)	Limit (W/kg)	Margin (W/kg)	Note(s)	Result
Base of EUT Facing Phantom With Display 90° to Keyboard	Flat (OVAL 3mm)	4183	0.019	1.600	1.581	1, 3, 4, 5	Complied
Base of EUT Facing Phantom With Display 90° to Keyboard	Flat (OVAL 3mm)	4183	0.011	1.600	1.589	2, 3, 4, 5	Complied

Note(s):

1. RMC 12.2kbps with Test loop mode 1 and TPC bits configured to All "1's" with HSDPA enabled.
2. FRC configured to HS-DPCCH Sub-test 1 and H-Set 1 and QPSK settings with HSPA enabled.
3. EUT was tested in the Body-Worn configuration with the bottom of the Notebook in direct contact against the flat phantom (0mm separation) and display open at 90 degrees to the keypad.
4. SAR test was performed in the middle channel only as the measured levels were <50% of the SAR limit.
5. WWAN SKU-850 module

Test of: Dell Latitude E4200 Notebook PC

To: OET Bulletin 65 Supplement C: (2001-01)

7.2.5. Specific Absorption Rate - GPRS1900 Body Configuration 1g

Test Summary:

Tissue Volume:	1g
Maximum Level (W/kg):	0.047

Environmental Conditions:

Temperature Variation in Lab (°C):	24.0 to 24.0
Temperature Variation in Liquid (°C):	24.0 to 24.0

Results:

EUT Position	Phantom Configuration	Channel Number	Level (W/kg)	Limit (W/kg)	Margin (W/kg)	Note(s)	Result
Base of EUT Facing Phantom With Display 90° to Keyboard	Flat (OVAL 3mm)	660	0.047	1.600	1.553	1, 2, 3	Complied

Note(s):

- EUT was tested in the Body-Worn configuration with the bottom of the Notebook in direct contact against the flat phantom (0mm separation) and display open at 90 degrees to the keypad.
- SAR test was performed in the middle channel only as the measured levels were <50% of the SAR limit as stated in the FCC Public Notice DA 02-1438 by the SCC-34/SC-2.
- WWAN SKU-850 module

Test of: Dell Latitude E4200 Notebook PC

To: OET Bulletin 65 Supplement C: (2001-01)

7.2.6. Specific Absorption Rate - EGPRS1900 Body Configuration 1g**Test Summary:**

Tissue Volume:	1g
Maximum Level (W/kg):	0.047

Environmental Conditions:

Temperature Variation in Lab (°C):	24.0 to 24.0
Temperature Variation in Liquid (°C):	24.0 to 24.0

Results:

EUT Position	Phantom Configuration	Channel Number	Level (W/kg)	Limit (W/kg)	Margin (W/kg)	Note(s)	Result
Base of EUT Facing Phantom With Display 90° to Keyboard	Flat (OVAL 3mm)	660	0.047	1.600	1.553	1, 2, 3	Complied
Base of EUT Facing Phantom With Display 90° to Keyboard	Flat (OVAL 3mm)	660	0.043	1.600	1.557	1, 2, 4	Complied

Note(s):

- EUT was tested in the Body-Worn configuration with the bottom of the Notebook in direct contact against the flat phantom (0mm separation) and display open at 90 degrees to the keypad.
- SAR test was performed in the middle channel only as the measured levels were <50% of the SAR limit as stated in the FCC Public Notice DA 02-1438 by the SCC-34/SC-2.
- WWAN SKU-850 module
- WWAN SKU-900 Module

Test of: Dell Latitude E4200 Notebook PC

To: OET Bulletin 65 Supplement C: (2001-01)

7.2.7. Specific Absorption Rate - UMTS FDD II Body Configuration 1g**Test Summary:**

Tissue Volume:	1g
Maximum Level (W/kg):	0.049

Environmental Conditions:

Temperature Variation in Lab (°C):	25.0 to 25.0
Temperature Variation in Liquid (°C):	23.2 to 23.2

Results:

EUT Position	Phantom Configuration	Channel Number	Level (W/kg)	Limit (W/kg)	Margin (W/kg)	Note(s)	Result
Base of EUT Facing Phantom With Display 90° to Keyboard	Flat (OVAL 3mm)	9400	0.041	1.600	1.559	1, 2, 3, 4	Complied
Base of EUT Facing Phantom With Display 90° to Keyboard	Flat (OVAL 3mm)	9400	0.049	1.600	1.551	1, 2, 3, 5	Complied

Note(s):

1. RMC 12.2kbps with Test loop mode 1 and TPC bits configured to All "1's"
2. EUT was tested in the Body-Worn configuration with the bottom of the Notebook in direct contact against the flat phantom (0mm separation) and display open at 90 degrees to the keypad.
3. SAR test was performed in the middle channel only as the measured levels were <50% of the SAR limit.
4. WWAN SKU-850 module
5. WWAN SKU-900 Module

Test of: Dell Latitude E4200 Notebook PC

To: OET Bulletin 65 Supplement C: (2001-01)

7.2.8. Specific Absorption Rate - UMTS FDD II + HSPA Body Configuration 1g**Test Summary:**

Tissue Volume:	1g
Maximum Level (W/kg):	0.032

Environmental Conditions:

Temperature Variation in Lab (°C):	25.0 to 25.0
Temperature Variation in Liquid (°C):	23.4 to 23.4

Results:

EUT Position	Phantom Configuration	Channel Number	Level (W/kg)	Limit (W/kg)	Margin (W/kg)	Note(s)	Result
Base of EUT Facing Phantom With Display 90° to Keyboard	Flat (OVAL 3mm)	9400	0.014	1.600	1.586	1, 3, 4, 5	Complied
Base of EUT Facing Phantom With Display 90° to Keyboard	Flat (OVAL 3mm)	9400	0.032	1.600	1.568	2, 3, 4, 5	Complied

Note(s):

1. RMC 12.2kbps with Test loop mode 1 and TPC bits configured to All "1's" with HSDPA enabled.
2. FRC configured to HS-DPCCH Sub-test 1 and H-Set 1 and QPSK settings with HSPA enabled.
3. EUT was tested in the Body-Worn configuration with the bottom of the Notebook in direct contact against the flat phantom (0mm separation) and display open at 90 degrees to the keypad.
4. SAR test was performed in the middle channel only as the measured levels were <50% of the SAR limit.
5. WWAN SKU-850 module

Test of: Dell Latitude E4200 Notebook PC

To: OET Bulletin 65 Supplement C: (2001-01)

7.2.9. EIRP/ERP Measurement**SKU 850 - GPRS/EGPRS**

Channel Number	Frequency (MHZ)	GPRS TX Power before Test (dBm)	EGPRS TX Power before Test (dBm)	Note
128	824.2	27.38	27.07	Max Average Power
189	836.4	27.50	27.17	Max Average Power
251	848.8	27.84	27.33	Max Average Power
512	1850.2	22.91	23.44	Max Average Power
660	1879.8	23.02	23.54	Max Average Power
810	1909.8	23.07	23.15	Max Average Power

SKU 900 - GPRS/EGPRS

Channel Number	Frequency (MHZ)	GPRS TX Power before Test (dBm)	EGPRS TX Power before Test (dBm)	Note
128	824.2	28.71	28.71	Max Average Power
189	836.4	28.87	28.86	Max Average Power
251	848.8	29.05	29.07	Max Average Power
512	1850.2	23.41	23.46	Max Average Power
660	1879.8	23.48	23.39	Max Average Power
810	1909.8	23.39	23.29	Max Average Power

Test of: Dell Latitude E4200 Notebook PC

To: OET Bulletin 65 Supplement C: (2001-01)

UMTS/HSPA – Average Power Measurements

850 MHz SKU – F3607gw KRD 131 15/11 R1B, 2/CXC 172 6612/11 R1B01, 004401700230929, R1G05; SN: A400840905

Modes		HSDPA				HSPA					WCDMA
Sets		1	2	3	4	1	2	3	4	5	Voice / RMC 12.2kbps
Band	Channel	Power [dBm]	Power [dBm]	Power [dBm]	Power [dBm]	Power [dBm]	Power [dBm]	Power [dBm]	Power [dBm]	Power [dBm]	Power [dBm]
850	4132 4357	23.32	20.49	21.25	21.03	20.50	20.65	20.21	21.11	19.80	23.21
	4183 4408	23.62	22.46	21.57	20.83	20.95	20.86	20.05	22.09	20.57	23.49
	4233 4458	23.36	22.05	21.24	21.06	20.45	20.55	20.25	21.74	20.26	23.27
1900	9262 9662	20.44	18.85	17.82	17.64	18.95	19.25	17.29	19.66	18.98	19.83
	9400 9800	21.32	19.79	18.62	18.36	18.91	20.08	18.11	19.62	19.43	20.67
	9538 9938	20.96	19.42	18.28	17.87	18.66	19.82	17.76	20.14	18.69	20.29
βc		2	12	15	15	11	6	15	2	15	
βd		15	15	8	4	15	15	9	15	15	
ΔACK, ΔNACK, ΔCQI		8	8	8	8	8	8	8	8	8	
AGV		-	-	-	-	20	12	15	17	21	

UMTS/HSPA – Average Power Measurements

900 MHz SKU– F3607gw KRD 131 15/12 R1A, 00441700232164, SN:A400841952

Modes		HSDPA				HSPA					WCDMA
Sets		1	2	3	4	1	2	3	4	5	Voice / RMC 12.2kbps
Band	Channel	Power [dBm]	Power [dBm]	Power [dBm]	Power [dBm]	Power [dBm]	Power [dBm]	Power [dBm]	Power [dBm]	Power [dBm]	Power [dBm]
1900	9262 9662	19.66	18.22	17.13	17.05	18.59	18.61	18.37	18.70	18.52	19.67
	9400 9800	20.76	19.13	17.89	17.72	19.48	19.14	19.38	19.72	19.11	20.62
	9538 9938	20.67	18.96	17.66	17.59	18.78	18.52	18.66	20.21	18.95	20.55
βc		2	12	15	15	11	6	15	2	15	
βd		15	15	8	4	15	15	9	15	15	
ΔACK, ΔNACK, ΔCQI		8	8	8	8	8	8	8	8	8	
AGV		-	-	-	-	20	12	15	17	21	

Test of: Dell Latitude E4200 Notebook PC

To: OET Bulletin 65 Supplement C: (2001-01)

* Prior to commencement of SAR testing the module power levels were measured in both HSPA and 3G RMC 12.2kbps modes and compared to ensure the correct mode of operation had been established.

The following tables taken from FCC 3G SAR procedures (KDB 941225 D01 SAR test for 3G devices v02) below were applied using an Agilent 8960 series 10 wireless communications test set which supports 3G / HSDPA release 5 / HSPA release 6.

Test of: Dell Latitude E4200 Notebook PC

To: OET Bulletin 65 Supplement C: (2001-01)

Sub-test 1 Setup for Release 5 HSDPA

Sub-test	β_c	β_d	B_d (SF)	β_c/β_d	$\beta_{hs}^{(1)}$	SM (dB) ⁽²⁾
1	2/15	15/15	64	2/15	4/15	0.0
2	12/15 ⁽³⁾	15/15 ⁽³⁾	64	12/15 ⁽³⁾	24/15	1.0
3	15/15	8/15	64	15/8	30/15	1.5
4	15/15	4/15	64	15/4	30/15	1.5

Note 1: Δ_{ACK} , Δ_{NACK} and $\Delta_{CQI} = 8 \Leftrightarrow A_{hs} = \beta_{hs}/\beta_c = 30/15 \Leftrightarrow \beta_{hs} = 30/15 * \beta_c$ Note 2: CM = 1 for $\beta_c/\beta_d = 12/15$, $B_{hs}/\beta_c = 24/15$ Note 3: For subtest 2 the β_c/β_d ratio of 12/15 for the TFC during the measurement period (TF1, TF0) is achieved by setting the signalled gain factors for the reference TFC (TF1, TF1) to $\beta_c = 11/15$ and $\beta_d = 15/15$ **Sub-test 5 Setup for Release 6 HSPA**

Sub-test	β_c	β_d	B_d (SF)	β_c/β_d	$\beta_{hs}^{(1)}$	B_{oc}	B_{od}	B_{od} (SF)	B_{od} (codes)	CM ⁽²⁾ (dB)	MPR (dB)	AG ⁽⁴⁾ Index	E- TFCI
1	11/15 ⁽³⁾	15/15 ⁽³⁾	64	11/15 ⁽³⁾	22/15	209/225	1039/225	4	1	1.0	0.0	20	75
2	6/15	15/15	64	6/15	12/15	12/15	94/75	4	1	3.0	2.0	12	67
3	15/15	9/15	64	15/9	30/15	31/15	$B_{a11}: 47/15$ $B_{a12}: 47/15$	4	1	2.0	1.0	15	92
4	2/15	15/15	64	2/15	2/15	2/15	56/75	4	1	3.0	2.0	17	71
5	15/15 ⁽⁴⁾	15/15 ⁽⁴⁾	64	15/15 ⁽⁴⁾	24/15	24/15	134/15	4	1	1.0	0.0	21	81

Note 1: Δ_{ACK} , Δ_{NACK} and $\Delta_{CQI} = 8 \Leftrightarrow A_{hs} = \beta_{hs}/\beta_c = 30/15 \Leftrightarrow \beta_{hs} = 30/15 * \beta_c$ Note 2: CM = 1 for $\beta_c/\beta_d = 12/15$, $B_{hs}/\beta_c = 24/15$. For all other combinations of DPDCH, DPCCH, HS-DPCCH, E-DPDCH AND E-DPCCH for the MPR is based on the relative CM difference.Note 3: For subtest 1 the β_c/β_d ratio of 11/15 for the TFC during the measurement period (TF1, TF0) is achieved by setting the signalled gain factors for the reference TFC (TF1, TF1) to $\beta_c = 10/15$ and $\beta_d = 15/15$.Note 4: For subtest 5 the β_c/β_d ratio of 15/15 for the TFC during the measurement period (TF1, TF0) is achieved by setting the signalled gain factors for the reference TFC (TF1, TF1) to $\beta_c = 14/15$ and $\beta_d = 15/15$.

Note 5: Testing UE using E-DPDCH Physical Layer category 1 Sub-test 3 is not required according to TS 25.306 Table 5.1g.

Note 6: B_{od} can not be set directly; it is set by Absolute Grant Value.

Test of: Dell Latitude E4200 Notebook PC

To: OET Bulletin 65 Supplement C: (2001-01)

8. Measurement Uncertainty

No measurement or test can ever be perfect and the imperfections give rise to error of measurement in the results. Consequently, the result of a measurement is only an approximation to the value of the measurand (the specific quantity subject to measurement) and is only complete when accompanied by a statement of the uncertainty of the approximation.

The expression of uncertainty of a measurement result allows realistic comparison of results with reference values and limits given in specifications and standards.

The uncertainty of the result may need to be taken into account when interpreting the measurement results.

The reported expanded uncertainties below are based on a standard uncertainty multiplied by an appropriate coverage factor, such that a confidence level of approximately 95% is maintained. For the purposes of this document “approximately” is interpreted as meaning “effectively” or “for most practical purposes”.

Test Name	Confidence Level	Calculated Uncertainty
Specific Absorption Rate- GPRS850 / GPRS900 Body Configuration 1g	95%	18.03%
Specific Absorption Rate- GPRS1900 Body Configuration 1g	95%	18.30%
Specific Absorption Rate- WCDMA FDD 1 Body Configuration 1g	95%	18.19%

The methods used to calculate the above uncertainties are in line with those recommended within the various measurement specifications. Where measurement specifications do not include guidelines for the evaluation of measurement uncertainty, the published guidance of the appropriate accreditation body is followed.

Test of: Dell Latitude E4200 Notebook PC

To: OET Bulletin 65 Supplement C: (2001-01)

Measurement Uncertainty (Continued)**8.1. Specific Absorption Rate Uncertainty at 850 MHz Body 1g, GPRS Modulation Scheme calculated in accordance with IEC 62209-2 & IEEE 1528**

Type	Source of uncertainty	+ Value	- Value	Probability Distribution	Divisor	C _i (10g)	Standard Uncertainty		v _i or v _{eff}
							+ u (%)	- u (%)	
B	Probe calibration	11.000	11.000	normal (k=2)	2.0000	1.0000	5.500	5.500	∞
B	Axial Isotropy	0.500	0.500	normal (k=2)	2.0000	1.0000	0.250	0.250	∞
B	Hemispherical Isotropy	2.600	2.600	normal (k=2)	2.0000	1.0000	1.300	1.300	∞
B	Spatial Resolution	0.500	0.500	Rectangular	1.7321	1.0000	0.289	0.289	∞
B	Boundary Effect	0.769	0.769	Rectangular	1.7321	1.0000	0.444	0.444	∞
B	Linearity	0.600	0.600	Rectangular	1.7321	1.0000	0.346	0.346	∞
B	Detection Limits	0.200	0.200	Rectangular	1.7321	1.0000	0.115	0.115	∞
B	Readout Electronics	0.560	0.560	normal (k=2)	2.0000	1.0000	0.280	0.280	∞
B	Response Time	0.000	0.000	Rectangular	1.7321	1.0000	0.000	0.000	∞
B	Integration Time	1.730	1.730	Rectangular	1.7321	1.0000	0.999	0.999	∞
B	RF Ambient conditions	3.000	3.000	Rectangular	1.7321	1.0000	1.732	1.732	∞
B	Probe Positioner Mechanical Restrictions	4.000	4.000	Rectangular	1.7321	1.0000	2.309	2.309	∞
B	Probe Positioning with regard to Phantom Shell	2.850	2.850	Rectangular	1.7321	1.0000	1.645	1.645	∞
B	Extrapolation and integration/ Maximum SAR evaluation	5.080	5.080	Rectangular	1.7321	1.0000	2.933	2.933	∞
A	Test Sample Positioning	0.584	0.584	normal (k=1)	1.0000	1.0000	0.584	0.584	10
A	Device Holder uncertainty	0.154	0.154	normal (k=1)	1.0000	1.0000	0.154	0.154	10
B	Phantom Uncertainty	4.000	4.000	Rectangular	1.7321	1.0000	2.309	2.309	∞
B	Drift of output power	5.000	5.000	Rectangular	1.7321	1.0000	2.887	2.887	∞
B	Liquid Conductivity (target value)	5.000	5.000	Rectangular	1.7321	0.6400	1.848	1.848	∞
A	Liquid Conductivity (measured value)	3.600	3.600	normal (k=1)	1.0000	0.6400	2.304	2.304	5
B	Liquid Permittivity (target value)	5.000	5.000	Rectangular	1.7321	0.6000	1.732	1.732	∞
A	Liquid Permittivity (measured value)	4.000	4.000	normal (k=1)	1.0000	0.6000	2.400	2.400	5
	Combined standard uncertainty			t-distribution			9.20	9.20	>500
	Expanded uncertainty			k = 1.96			18.03	18.03	>500

Test of: Dell Latitude E4200 Notebook PC

To: OET Bulletin 65 Supplement C: (2001-01)

8.2. Specific Absorption Rate Uncertainty at 1900 MHz Body 1g, GPRS Modulation Scheme calculated in accordance with IEC 62209-2 & IEEE 1528

Type	Source of uncertainty	+ Value	- Value	Probability Distribution	Divisor	C _i (10g)	Standard Uncertainty		v _i or v _{eff}
							+ u (%)	- u (%)	
B	Probe calibration	11.000	11.000	normal (k=2)	2.0000	1.0000	5.500	5.500	∞
B	Axial Isotropy	0.500	0.500	normal (k=2)	2.0000	1.0000	0.250	0.250	∞
B	Hemispherical Isotropy	2.600	2.600	normal (k=2)	2.0000	1.0000	1.300	1.300	∞
B	Spatial Resolution	0.500	0.500	Rectangular	1.7321	1.0000	0.289	0.289	∞
B	Boundary Effect	0.769	0.769	Rectangular	1.7321	1.0000	0.444	0.444	∞
B	Linearity	0.600	0.600	Rectangular	1.7321	1.0000	0.346	0.346	∞
B	Detection Limits	0.200	0.200	Rectangular	1.7321	1.0000	0.115	0.115	∞
B	Readout Electronics	0.560	0.560	normal (k=2)	2.0000	1.0000	0.280	0.280	∞
B	Response Time	0.000	0.000	Rectangular	1.7321	1.0000	0.000	0.000	∞
B	Integration Time	1.730	1.730	Rectangular	1.7321	1.0000	0.999	0.999	∞
B	RF Ambient conditions	3.000	3.000	Rectangular	1.7321	1.0000	1.732	1.732	∞
B	Probe Positioner Mechanical Restrictions	4.000	4.000	Rectangular	1.7321	1.0000	2.309	2.309	∞
B	Probe Positioning with regard to Phantom Shell	2.850	2.850	Rectangular	1.7321	1.0000	1.645	1.645	∞
B	Extrapolation and integration/ Maximum SAR evaluation	5.080	5.080	Rectangular	1.7321	1.0000	2.933	2.933	∞
A	Test Sample Positioning	0.584	0.584	normal (k=1)	1.0000	1.0000	0.584	0.584	10
A	Device Holder uncertainty	0.154	0.154	normal (k=1)	1.0000	1.0000	0.154	0.154	10
B	Phantom Uncertainty	4.000	4.000	Rectangular	1.7321	1.0000	2.309	2.309	∞
B	Drift of output power	5.000	5.000	Rectangular	1.7321	1.0000	2.887	2.887	∞
B	Liquid Conductivity (target value)	5.000	5.000	Rectangular	1.7321	0.6400	1.848	1.848	∞
A	Liquid Conductivity (measured value)	4.170	4.170	normal (k=1)	1.0000	0.6400	2.669	2.669	5
B	Liquid Permittivity (target value)	5.000	5.000	Rectangular	1.7321	0.6000	1.732	1.732	∞
A	Liquid Permittivity (measured value)	4.230	4.230	normal (k=1)	1.0000	0.6000	2.538	2.538	5
	Combined standard uncertainty			t-distribution			9.34	9.34	>400
	Expanded uncertainty			k = 1.96			18.30	18.30	>400

Test of: Dell Latitude E4200 Notebook PC

To: OET Bulletin 65 Supplement C: (2001-01)

8.3. Specific Absorption Rate Uncertainty at 1900 MHz Body 1g, WCDMA Modulation Scheme calculated in accordance with IEC 62209-2 & IEEE 1528

Type	Source of uncertainty	+ Value	- Value	Probability Distribution	Divisor	C _i (10g)	Standard Uncertainty		v _i or v _{eff}
							+ u (%)	- u (%)	
B	Probe calibration	11.000	11.000	normal (k=2)	2.0000	1.0000	5.500	5.500	∞
B	Axial Isotropy	0.500	0.500	normal (k=2)	2.0000	1.0000	0.250	0.250	∞
B	Hemispherical Isotropy	2.600	2.600	normal (k=2)	2.0000	1.0000	1.300	1.300	∞
B	Spatial Resolution	0.500	0.500	Rectangular	1.7321	1.0000	0.289	0.289	∞
B	Boundary Effect	0.769	0.769	Rectangular	1.7321	1.0000	0.444	0.444	∞
B	Linearity	0.600	0.600	Rectangular	1.7321	1.0000	0.346	0.346	∞
B	Detection Limits	0.200	0.200	Rectangular	1.7321	1.0000	0.115	0.115	∞
B	Readout Electronics	0.560	0.560	normal (k=2)	2.0000	1.0000	0.280	0.280	∞
B	Response Time	0.000	0.000	Rectangular	1.7321	1.0000	0.000	0.000	∞
B	Integration Time	0.000	0.000	Rectangular	1.7321	1.0000	0.000	0.000	∞
B	RF Ambient conditions	3.000	3.000	Rectangular	1.7321	1.0000	1.732	1.732	∞
B	Probe Positioner Mechanical Restrictions	4.000	4.000	Rectangular	1.7321	1.0000	2.309	2.309	∞
B	Probe Positioning with regard to Phantom Shell	2.850	2.850	Rectangular	1.7321	1.0000	1.645	1.645	∞
B	Extrapolation and integration/ Maximum SAR evaluation	5.080	5.080	Rectangular	1.7321	1.0000	2.933	2.933	∞
A	Test Sample Positioning	0.584	0.584	normal (k=1)	1.0000	1.0000	0.584	0.584	10
A	Device Holder uncertainty	0.154	0.154	normal (k=1)	1.0000	1.0000	0.154	0.154	10
B	Phantom Uncertainty	4.000	4.000	Rectangular	1.7321	1.0000	2.309	2.309	∞
B	Drift of output power	5.000	5.000	Rectangular	1.7321	1.0000	2.887	2.887	∞
B	Liquid Conductivity (target value)	5.000	5.000	Rectangular	1.7321	0.6400	1.848	1.848	∞
A	Liquid Conductivity (measured value)	4.170	4.170	normal (k=1)	1.0000	0.6400	2.669	2.669	5
B	Liquid Permittivity (target value)	5.000	5.000	Rectangular	1.7321	0.6000	1.732	1.732	∞
A	Liquid Permittivity (measured value)	4.230	4.230	normal (k=1)	1.0000	0.6000	2.538	2.538	5
	Combined standard uncertainty			t-distribution			9.28	9.28	>400
	Expanded uncertainty			k = 1.96			18.19	18.19	>400

Test of: Dell Latitude E4200 Notebook PC

To: OET Bulletin 65 Supplement C: (2001-01)

Appendix 1. Test Equipment Used

RFI No.	Instrument	Manufacturer	Type No.	Serial No.	Date Last Calibrated	Cal. Interval (Months)
A034	Narda 20W Termination	Narda	374BNM	8706	Calibrated as part of system	-
A1094	Digital Camera	Sony	MVC - FD81	125805	-	-
A1097	SMA Directional Coupler	MiDISCO	MDC6223-30	None	Calibrated as part of system	-
A1137	3dB Attenuator	Narda	779	04690	Calibrated as part of system	-
A1174	Dielectric Probe Kit	Agilent Technologies	85070C	Us99360072	Calibrated before use	-
A1328	Handset Positioner	Schmid & Partner Engineering AG	Modification	SD 000 H01 DA	-	-
A1182	Handset Positioner	Schmid & Partner Engineering AG	V3.0	None	-	-
A1234	Data Acquisition Electronics	Schmid & Partner Engineering AG	DAE3	450	30 April 2009	12
A1378	Probe	Schmid & Partner Engineering AG	EX3 DV3	3508	26 June 2009	12
A1498	Oval Phantom 3mm	MCL	OVAL 3mm	None	Calibrated before use	-
A1566	SAM Phantom	Schmid & Partner Engineering AG	SAM a	002	Calibrated before use	-
A1329	900 MHz Dipole Kit	Schmid & Partner Engineering AG	D900V2	185	18 Aug 2009	24
A1237	1900 MHz Dipole Kit	Schmid & Partner Engineering AG	D1900V2	540	26 June 2009	24
A1474	Amplifier	Mini-Circuits	ZVE-8G	638700305	Calibrated as part of system	-
A215	20 dB Attenuator	Narda	766-20	9402	Calibrated as part of system	-
A1531	Antenna	AARONIA AG	7025	02458	-	-
C1144	Cable	Rosenberger MICRO-COAX	FA147AF00 1503030	41842-1	Calibrated as part of system	-
C1145	Cable	Rosenberger MICRO-COAX	FA147AF00 3003030	41843-1	Calibrated as part of system	-
C1146	Cable	Rosenberger MICRO-COAX	FA147AF03 0003030	41752-1	Calibrated as part of system	-

Test of: Dell Latitude E4200 Notebook PC

To: OET Bulletin 65 Supplement C: (2001-01)

RFI No.	Instrument	Manufacturer	Type No.	Serial No.	Date Last Calibrated	Cal. Interval (Months)
C1092	Cable	RS Components	293-334	1087200-3 3402	Internal Calibration	-
G0528	Robot Power Supply	Schmid & Partner Engineering AG	DASY	None	Calibrated before use	-
G087	PSU	Thurlby Thandar	CPX200	100701	Calibrated before use	-
M1015	Network Analyser	Agilent Technologies	8753ES	US39172406	15 Sept 2009	12
M1047	Robot Arm	Staubli	RX908 L	F00/SD89A1/ A/01	Calibrated before use	-
M1159	Signal Generator	Agilent Technologies	E8241A	US42110332	Internal Checked 05 August 2009 (Monitoring use only)	4
M1071	Spectrum Analyzer	Agilent	HP8590E	3647U00514		-
M1044	Diode Power Sensor	Rohde & Schwarz	NRV-Z1	893350/019	19 May 2009	12
M265	Diode Power Sensor	Rohde & Schwarz	NRV-Z1	893350/017	19 May 2009	12
M263	Dual Channel Power Meter	Rohde & Schwarz	NRVD	826558/004	20 May 2009	12
M1270	Temperature/ Humidity/ Pressure Meter	RS Components	None	None	June 2008 (Internal Calibration)	12
S256	SAR Lab	RFI	Site 56	N/A	Calibrated before use	-

Test of: Dell Latitude E4200 Notebook PC

To: OET Bulletin 65 Supplement C: (2001-01)

A.1.1. Calibration Certificates

This section contains the calibration certificates and data for the Probe(s) and Dipole(s) used, which are not included in the total number of pages for this report.



Accredited by the Swiss Accreditation Service (SAS)
The Swiss Accreditation Service is one of the signatories to the EA
Multilateral Agreement for the recognition of calibration certificates

Accreditation No.: **SCS 108**

Client **RFI**

Certificate No: **EX3-3508_Jun09**

CALIBRATION CERTIFICATE

Object **EX3DV3 - SN:3508**

Calibration procedure(s) **QA CAL-01.v6, QA CAL-12.v5 and QA CAL-23.v3
Calibration procedure for dosimetric E-field probes**

Calibration date: **June 26, 2009**

Condition of the calibrated item **In Tolerance**

This calibration certificate documents the traceability to national standards, which realize the physical units of measurements (SI).
The measurements and the uncertainties with confidence probability are given on the following pages and are part of the certificate.

All calibrations have been conducted in the closed laboratory facility: environment temperature (22 ± 3)°C and humidity < 70%.

Calibration Equipment used (M&TE critical for calibration)

Primary Standards	ID #	Cal Date (Certificate No.)	Scheduled Calibration
Power meter E4419B	GB41293874	1-Apr-09 (No. 217-01030)	Apr-10
Power sensor E4412A	MY41495277	1-Apr-09 (No. 217-01030)	Apr-10
Power sensor E4412A	MY41498087	1-Apr-09 (No. 217-01030)	Apr-10
Reference 3 dB Attenuator	SN: S5054 (3c)	31-Mar-09 (No. 217-01026)	Mar-10
Reference 20 dB Attenuator	SN: S5086 (20b)	31-Mar-09 (No. 217-01028)	Mar-10
Reference 30 dB Attenuator	SN: S5129 (30b)	31-Mar-09 (No. 217-01027)	Mar-10
Reference Probe ES3DV2	SN: 3013	2-Jan-09 (No. ES3-3013_Jan09)	Jan-10
DAE4	SN: 660	9-Sep-08 (No. DAE4-660_Sep08)	Sep-09

Secondary Standards	ID #	Check Date (in house)	Scheduled Check
RF generator HP 8648C	US3642U01700	4-Aug-99 (in house check Oct-07)	In house check: Oct-09
Network Analyzer HP 8753E	US37390585	18-Oct-01 (in house check Oct-08)	In house check: Oct-09

	Name	Function	Signature
Calibrated by:	Jeton Kastrati	Laboratory Technician	
Approved by:	Katja Pokovic	Technical Manager	

Issued: June 26, 2009

This calibration certificate shall not be reproduced except in full without written approval of the laboratory.



Accredited by the Swiss Accreditation Service (SAS)

The Swiss Accreditation Service is one of the signatories to the EA
Multilateral Agreement for the recognition of calibration certificates

Accreditation No.: **SCS 108**

Glossary:

TSL	tissue simulating liquid
NORM _{x,y,z}	sensitivity in free space
ConvF	sensitivity in TSL / NORM _{x,y,z}
DCP	diode compression point
Polarization φ	φ rotation around probe axis
Polarization ϑ	ϑ rotation around an axis that is in the plane normal to probe axis (at measurement center), i.e., $\vartheta = 0$ is normal to probe axis

Calibration is Performed According to the Following Standards:

- IEEE Std 1528-2003, "IEEE Recommended Practice for Determining the Peak Spatial-Averaged Specific Absorption Rate (SAR) in the Human Head from Wireless Communications Devices: Measurement Techniques", December 2003
- IEC 62209-1, "Procedure to measure the Specific Absorption Rate (SAR) for hand-held devices used in close proximity to the ear (frequency range of 300 MHz to 3 GHz)", February 2005

Methods Applied and Interpretation of Parameters:

- NORM_{x,y,z}**: Assessed for E-field polarization $\vartheta = 0$ ($f \leq 900$ MHz in TEM-cell; $f > 1800$ MHz: R22 waveguide). NORM_{x,y,z} are only intermediate values, i.e., the uncertainties of NORM_{x,y,z} does not effect the E²-field uncertainty inside TSL (see below *ConvF*).
- NORM(f)_{x,y,z}** = NORM_{x,y,z} * *frequency_response* (see Frequency Response Chart). This linearization is implemented in DASY4 software versions later than 4.2. The uncertainty of the frequency response is included in the stated uncertainty of *ConvF*.
- DCP_{x,y,z}**: DCP are numerical linearization parameters assessed based on the data of power sweep (no uncertainty required). DCP does not depend on frequency nor media.
- ConvF and Boundary Effect Parameters**: Assessed in flat phantom using E-field (or Temperature Transfer Standard for $f \leq 800$ MHz) and inside waveguide using analytical field distributions based on power measurements for $f > 800$ MHz. The same setups are used for assessment of the parameters applied for boundary compensation (alpha, depth) of which typical uncertainty values are given. These parameters are used in DASY4 software to improve probe accuracy close to the boundary. The sensitivity in TSL corresponds to NORM_{x,y,z} * *ConvF* whereby the uncertainty corresponds to that given for *ConvF*. A frequency dependent *ConvF* is used in DASY version 4.4 and higher which allows extending the validity from ± 50 MHz to ± 100 MHz.
- Spherical isotropy (3D deviation from isotropy)**: in a field of low gradients realized using a flat phantom exposed by a patch antenna.
- Sensor Offset**: The sensor offset corresponds to the offset of virtual measurement center from the probe tip (on probe axis). No tolerance required.

Probe EX3DV3

SN:3508

Manufactured:	December 19, 2003
Last calibrated:	June 24, 2008
Recalibrated:	June 26, 2009

Calibrated for DASY Systems

(Note: non-compatible with DASY2 system!)

DASY - Parameters of Probe: EX3DV3 SN:3508

Sensitivity in Free Space^A

NormX	0.76 ± 10.1%	$\mu\text{V}/(\text{V}/\text{m})^2$
NormY	0.63 ± 10.1%	$\mu\text{V}/(\text{V}/\text{m})^2$
NormZ	0.66 ± 10.1%	$\mu\text{V}/(\text{V}/\text{m})^2$

Diode Compression^B

DCP X	95 mV
DCP Y	97 mV
DCP Z	94 mV

Sensitivity in Tissue Simulating Liquid (Conversion Factors)

Please see Page 8.

Boundary Effect

TSL **900 MHz** **Typical SAR gradient: 5 % per mm**

Sensor Center to Phantom Surface Distance		2.0 mm	3.0 mm
SAR _{be} [%]	Without Correction Algorithm	7.8	4.6
SAR _{be} [%]	With Correction Algorithm	0.5	0.3

TSL **1750 MHz** **Typical SAR gradient: 10 % per mm**

Sensor Center to Phantom Surface Distance		2.0 mm	3.0 mm
SAR _{be} [%]	Without Correction Algorithm	5.8	2.7
SAR _{be} [%]	With Correction Algorithm	0.7	0.5

Sensor Offset

Probe Tip to Sensor Center **1.0 mm**

The reported uncertainty of measurement is stated as the standard uncertainty of measurement multiplied by the coverage factor k=2, which for a normal distribution corresponds to a coverage probability of approximately 95%.

^A The uncertainties of NormX,Y,Z do not affect the E²-field uncertainty inside TSL (see Page 8).

^B Numerical linearization parameter: uncertainty not required.

Frequency Response of E-Field

(TEM-Cell:ifi110 EXX, Waveguide: R22)

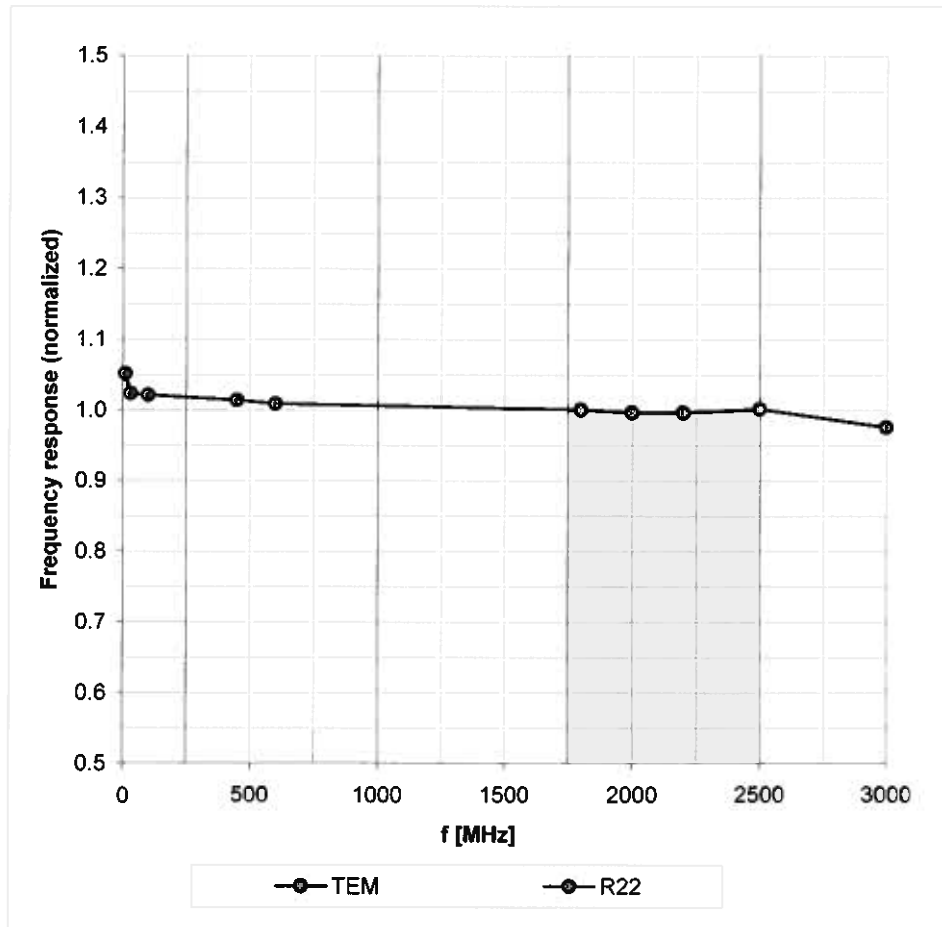

Uncertainty of Frequency Response of E-field: $\pm 6.3\%$ ($k=2$)

Receiving Pattern (ϕ), $\vartheta = 0^\circ$

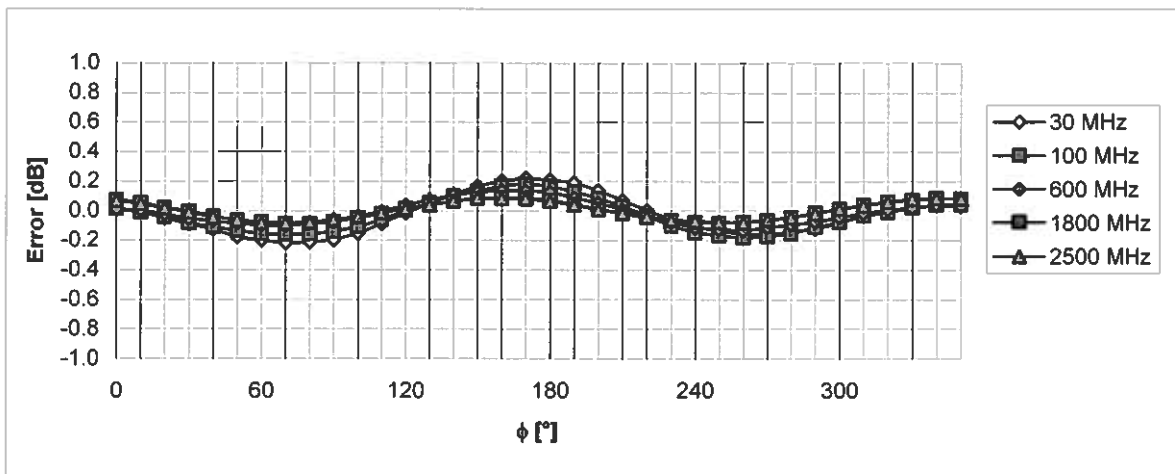
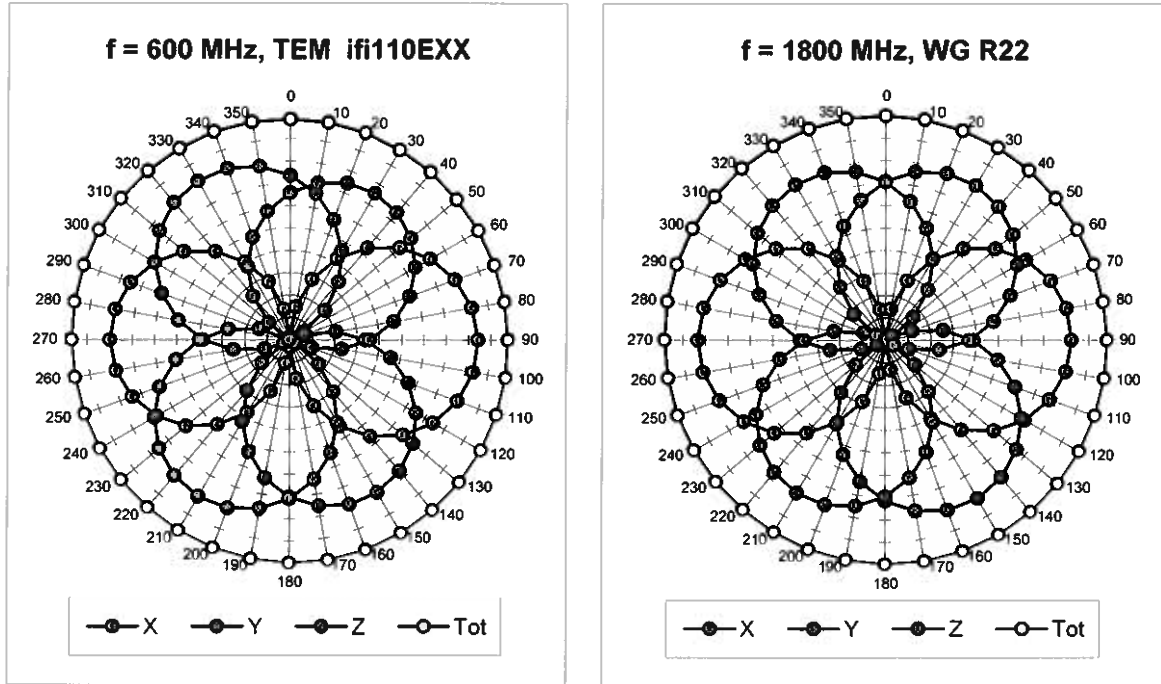

Uncertainty of Axial Isotropy Assessment: $\pm 0.5\%$ (k=2)

Dynamic Range f(SAR_{head}) (Waveguide R22, f = 1800 MHz)

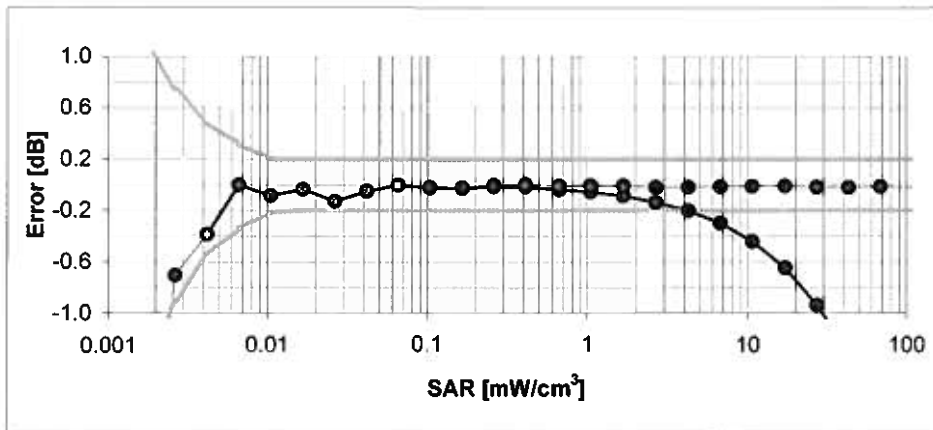
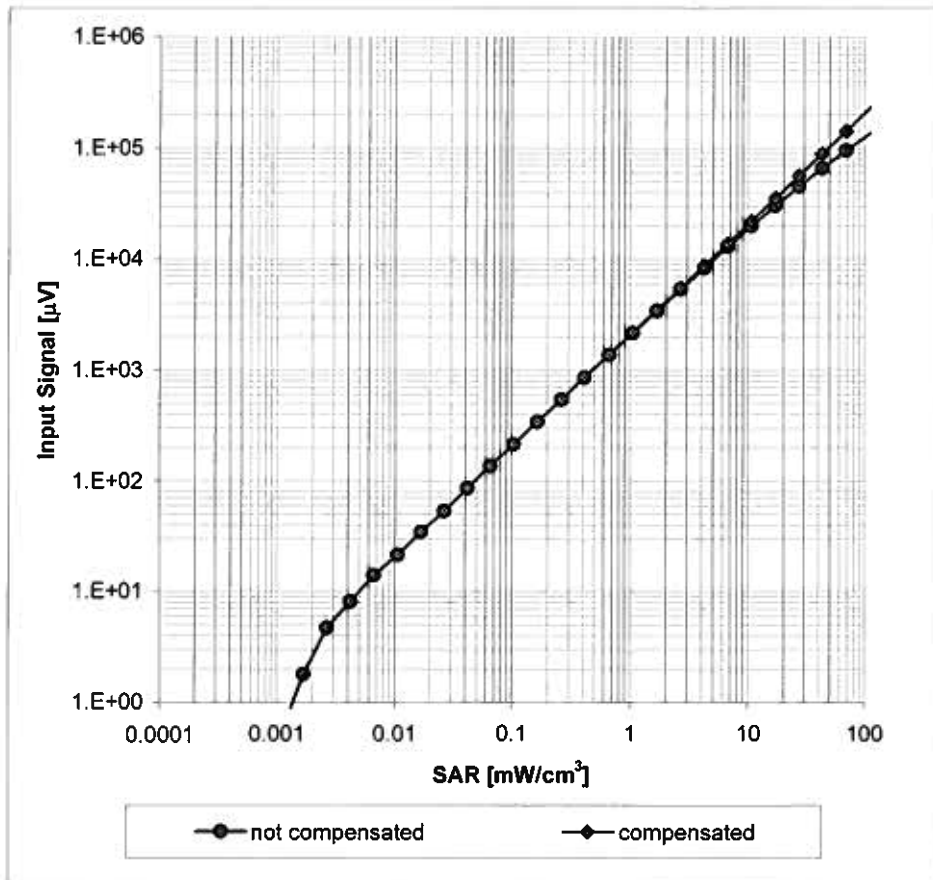

Uncertainty of Linearity Assessment: ± 0.6% (k=2)

Conversion Factor Assessment

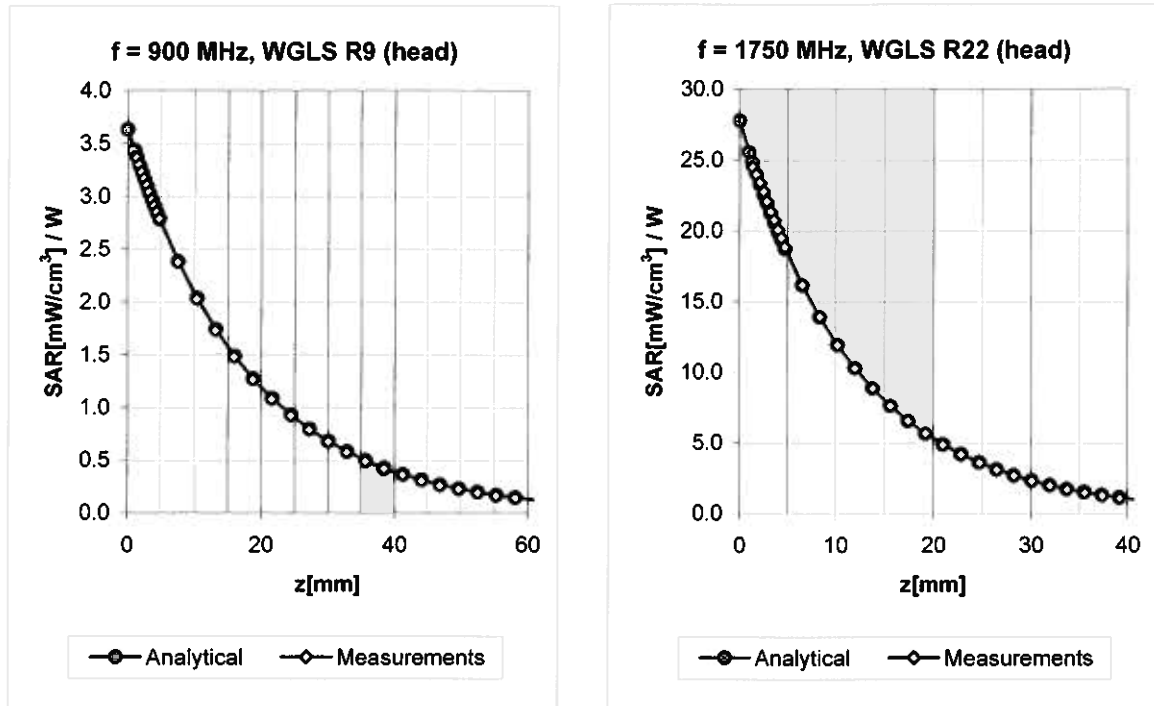

f [MHz]	Validity [MHz] ^c	TSL	Permittivity	Conductivity	Alpha	Depth	ConvF Uncertainty
450	± 50 / ± 100	Head	43.5 ± 5%	0.87 ± 5%	0.23	1.00	10.49 ± 13.3% (k=2)
900	± 50 / ± 100	Head	41.5 ± 5%	0.97 ± 5%	0.48	0.72	9.76 ± 11.0% (k=2)
1750	± 50 / ± 100	Head	40.1 ± 5%	1.37 ± 5%	0.57	0.63	8.82 ± 11.0% (k=2)
1900	± 50 / ± 100	Head	40.0 ± 5%	1.40 ± 5%	0.53	0.65	8.58 ± 11.0% (k=2)
2150	± 50 / ± 101	Head	39.7 ± 5%	1.53 ± 5%	0.36	0.69	8.33 ± 11.0% (k=2)
2450	± 50 / ± 100	Head	39.2 ± 5%	1.80 ± 5%	0.36	0.75	7.77 ± 11.0% (k=2)
450	± 50 / ± 100	Body	56.7 ± 5%	0.94 ± 5%	0.30	0.51	11.32 ± 13.3% (k=2)
900	± 50 / ± 100	Body	55.0 ± 5%	1.05 ± 5%	0.45	0.75	9.99 ± 11.0% (k=2)
1750	± 50 / ± 100	Body	53.4 ± 5%	1.49 ± 5%	0.55	0.63	8.59 ± 11.0% (k=2)
1900	± 50 / ± 100	Body	53.3 ± 5%	1.52 ± 5%	0.48	0.68	8.23 ± 11.0% (k=2)
2150	± 50 / ± 100	Body	53.0 ± 5%	1.75 ± 5%	0.30	0.92	8.27 ± 11.0% (k=2)
2450	± 50 / ± 100	Body	52.7 ± 5%	1.95 ± 5%	0.25	1.02	8.06 ± 11.0% (k=2)

^c The validity of ± 100 MHz only applies for DASY v4.4 and higher (see Page 2). The uncertainty is the RSS of the ConvF uncertainty at calibration frequency and the uncertainty for the indicated frequency band.

Deviation from Isotropy in HSL

Error (ϕ, ϑ), $f = 900$ MHz

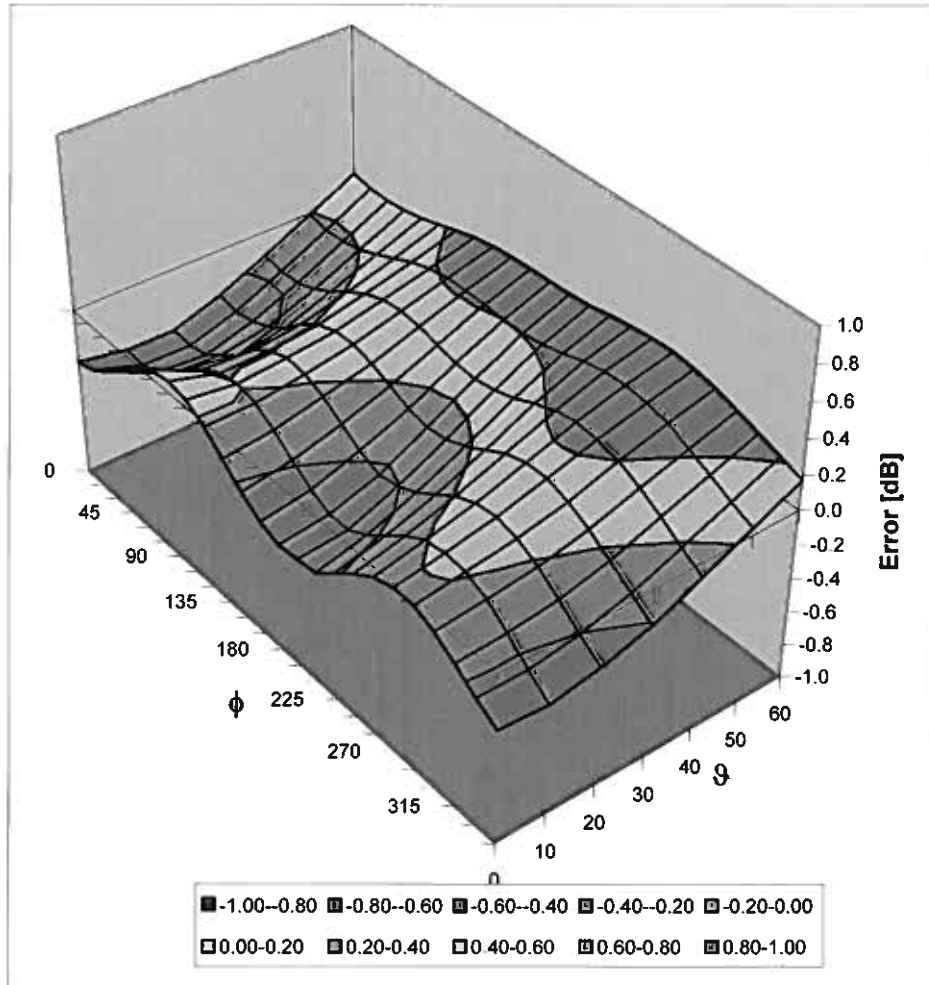

Uncertainty of Spherical Isotropy Assessment: $\pm 2.6\%$ ($k=2$)



Accredited by the Swiss Accreditation Service (SAS)
The Swiss Accreditation Service is one of the signatories to the EA
Multilateral Agreement for the recognition of calibration certificates

Accreditation No.: **SCS 108**

Client **RFI**

Certificate No: **D900V2-185_Aug09**

CALIBRATION CERTIFICATE

Object **D900V2 - SN: 185**

Calibration procedure(s) **QA CAL-05.v7
Calibration procedure for dipole validation kits**

Calibration date: **August 18, 2009**

Condition of the calibrated item **In Tolerance**

This calibration certificate documents the traceability to national standards, which realize the physical units of measurements (SI).
The measurements and the uncertainties with confidence probability are given on the following pages and are part of the certificate.

All calibrations have been conducted in the closed laboratory facility: environment temperature (22 ± 3)°C and humidity < 70%.

Calibration Equipment used (M&TE critical for calibration)

Primary Standards	ID #	Cal Date (Certificate No.)	Scheduled Calibration
Power meter EPM-442A	GB37480704	08-Oct-08 (No. 217-00898)	Oct-09
Power sensor HP 8481A	US37292783	08-Oct-08 (No. 217-00898)	Oct-09
Reference 20 dB Attenuator	SN: 5086 (20g)	31-Mar-09 (No. 217-01025)	Mar-10
Type-N mismatch combination	SN: 5047.2 / 06327	31-Mar-09 (No. 217-01029)	Mar-10
Reference Probe ES3DV3	SN: 3205	26-Jun-09 (No. ES3-3205_Jun09)	Jun-10
DAE4	SN: 601	07-Mar-09 (No. DAE4-601_Mar09)	Mar-10

Secondary Standards	ID #	Check Date (in house)	Scheduled Check
Power sensor HP 8481A	MY41092317	18-Oct-02 (in house check Oct-07)	In house check: Oct-09
RF generator R&S SMT-06	100005	4-Aug-99 (in house check Oct-07)	In house check: Oct-09
Network Analyzer HP 8753E	US37390585 S4206	18-Oct-01 (in house check Oct-08)	In house check: Oct-09

	Name	Function	Signature
Calibrated by:	Jeton Kastrati	Laboratory Technician	
Approved by:	Katja Pokovic	Technical Manager	

Issued: August 18, 2009

This calibration certificate shall not be reproduced except in full without written approval of the laboratory.



Accredited by the Swiss Accreditation Service (SAS)
The Swiss Accreditation Service is one of the signatories to the EA
Multilateral Agreement for the recognition of calibration certificates

Accreditation No.: **SCS 108**

Glossary:

TSL	tissue simulating liquid
ConvF	sensitivity in TSL / NORM x,y,z
N/A	not applicable or not measured

Calibration is Performed According to the Following Standards:

- a) IEEE Std 1528-2003, "IEEE Recommended Practice for Determining the Peak Spatial-Averaged Specific Absorption Rate (SAR) in the Human Head from Wireless Communications Devices: Measurement Techniques", December 2003
- b) IEC 62209-1, "Procedure to measure the Specific Absorption Rate (SAR) for hand-held devices used in close proximity to the ear (frequency range of 300 MHz to 3 GHz)", February 2005
- c) Federal Communications Commission Office of Engineering & Technology (FCC OET), "Evaluating Compliance with FCC Guidelines for Human Exposure to Radiofrequency Electromagnetic Fields; Additional Information for Evaluating Compliance of Mobile and Portable Devices with FCC Limits for Human Exposure to Radiofrequency Emissions", Supplement C (Edition 01-01) to Bulletin 65

Additional Documentation:

- d) DASY4/5 System Handbook

Methods Applied and Interpretation of Parameters:

- *Measurement Conditions:* Further details are available from the Validation Report at the end of the certificate. All figures stated in the certificate are valid at the frequency indicated.
- *Antenna Parameters with TSL:* The dipole is mounted with the spacer to position its feed point exactly below the center marking of the flat phantom section, with the arms oriented parallel to the body axis.
- *Feed Point Impedance and Return Loss:* These parameters are measured with the dipole positioned under the liquid filled phantom. The impedance stated is transformed from the measurement at the SMA connector to the feed point. The Return Loss ensures low reflected power. No uncertainty required.
- *Electrical Delay:* One-way delay between the SMA connector and the antenna feed point. No uncertainty required.
- *SAR measured:* SAR measured at the stated antenna input power.
- *SAR normalized:* SAR as measured, normalized to an input power of 1 W at the antenna connector.
- *SAR for nominal TSL parameters:* The measured TSL parameters are used to calculate the nominal SAR result.

Measurement Conditions

DASY system configuration, as far as not given on page 1.

DASY Version	DASY5	V5.0
Extrapolation	Advanced Extrapolation	
Phantom	Modular Flat Phantom V4.9	
Distance Dipole Center - TSL	15 mm	with Spacer
Zoom Scan Resolution	dx, dy, dz = 5 mm	
Frequency	900 MHz ± 1 MHz	

Head TSL parameters

The following parameters and calculations were applied.

	Temperature	Permittivity	Conductivity
Nominal Head TSL parameters	22.0 °C	41.5	0.97 mho/m
Measured Head TSL parameters	(22.0 ± 0.2) °C	40.4 ± 6 %	0.96 mho/m ± 6 %
Head TSL temperature during test	(22.4 ± 0.2) °C	----	----

SAR result with Head TSL

SAR averaged over 1 cm³ (1 g) of Head TSL	Condition	
SAR measured	250 mW input power	2.75 mW / g
SAR normalized	normalized to 1W	11.0 mW / g
SAR for nominal Head TSL parameters ¹	normalized to 1W	11.0 mW / g ± 17.0 % (k=2)

SAR averaged over 10 cm³ (10 g) of Head TSL	condition	
SAR measured	250 mW input power	1.76 mW / g
SAR normalized	normalized to 1W	7.04 mW / g
SAR for nominal Head TSL parameters ¹	normalized to 1W	7.06 mW / g ± 16.5 % (k=2)

¹ Correction to nominal TSL parameters according to d), chapter "SAR Sensitivities"

Body TSL parameters

The following parameters and calculations were applied.

	Temperature	Permittivity	Conductivity
Nominal Body TSL parameters	22.0 °C	55.0	1.05 mho/m
Measured Body TSL parameters	(22.0 ± 0.2) °C	52.7 ± 6 %	1.06 mho/m ± 6 %
Body TSL temperature during test	(22.0 ± 0.2) °C	----	----

SAR result with Body TSL

SAR averaged over 1 cm ³ (1 g) of Body TSL	Condition	
SAR measured	250 mW input power	2.80 mW / g
SAR normalized	normalized to 1W	11.2 mW / g
SAR for nominal Body TSL parameters ²	normalized to 1W	11.0 mW / g ± 17.0 % (k=2)

SAR averaged over 10 cm ³ (10 g) of Body TSL	condition	
SAR measured	250 mW input power	1.81 mW / g
SAR normalized	normalized to 1W	7.24 mW / g
SAR for nominal Body TSL parameters ²	normalized to 1W	7.16 mW / g ± 16.5 % (k=2)

² Correction to nominal TSL parameters according to d), chapter "SAR Sensitivities"

Appendix

Antenna Parameters with Head TSL

Impedance, transformed to feed point	49.5 Ω - 10.3 j Ω
Return Loss	- 19.7 dB

Antenna Parameters with Body TSL

Impedance, transformed to feed point	45.5 Ω - 11.2 j Ω
Return Loss	- 18.0 dB

General Antenna Parameters and Design

Electrical Delay (one direction)	1.403 ns
----------------------------------	----------

After long term use with 100W radiated power, only a slight warming of the dipole near the feedpoint can be measured.

The dipole is made of standard semirigid coaxial cable. The center conductor of the feeding line is directly connected to the second arm of the dipole. The antenna is therefore short-circuited for DC-signals.

No excessive force must be applied to the dipole arms, because they might bend or the soldered connections near the feedpoint may be damaged.

Additional EUT Data

Manufactured by	SPEAG
Manufactured on	May 27, 2003

DASY5 Validation Report for Head TSL

Date/Time: 18.08.2009 08:57:04

Test Laboratory: SPEAG, Zurich, Switzerland

DUT: Dipole 900 MHz; Type: D900V2; Serial: D900V2 - SN:185

Communication System: CW-900; Frequency: 900 MHz; Duty Cycle: 1:1

Medium: HSL 900 MHz

Medium parameters used: $f = 900 \text{ MHz}$; $\sigma = 0.96 \text{ mho/m}$; $\epsilon_r = 40.6$; $\rho = 1000 \text{ kg/m}^3$

Phantom section: Flat Section

Measurement Standard: DASY5 (IEEE/IEC)

DASY5 Configuration:

- Probe: ES3DV3 - SN3205; ConvF(5.88, 5.88, 5.88); Calibrated: 26.06.2009
- Sensor-Surface: 3mm (Mechanical Surface Detection)
- Electronics: DAE4 Sn601; Calibrated: 07.03.2009
- Phantom: Flat Phantom 4.9L; Type: QD000P49AA; Serial: 1001
- Measurement SW: DASY5, V5.0 Build 120; SEMCAD X Version 13.4 Build 45

Pin=250mW; dip=15mm/Zoom Scan (7x7x7)/Cube 0: Measurement grid: $dx=5\text{mm}$, $dy=5\text{mm}$, $dz=5\text{mm}$

Reference Value = 59.7 V/m; Power Drift = 0.015 dB

Peak SAR (extrapolated) = 4.17 W/kg

SAR(1 g) = 2.75 mW/g; SAR(10 g) = 1.76 mW/g

Maximum value of SAR (measured) = 3.23 mW/g

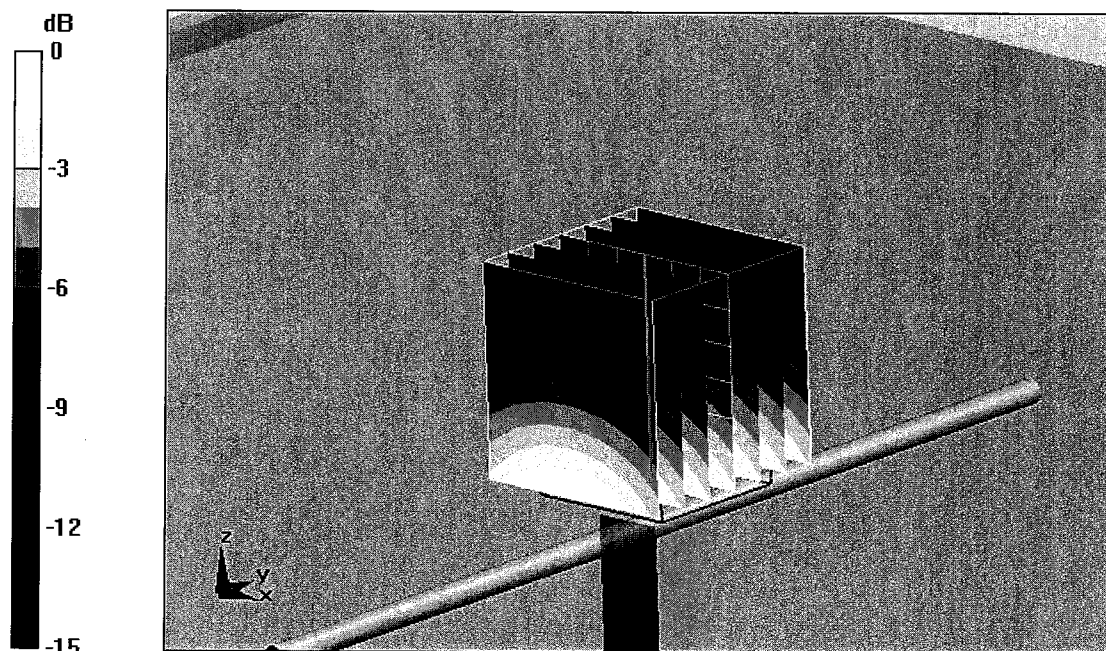

0 dB = 3.23mW/g

Impedance Measurement Plot for Head TSL

18 Aug 2009 08:06:03

CH1 S11 1 U FS 1: 49.496 Ω -10.342 Ω 17.099 pF 900.000 000 MHz

*
De1
Cor

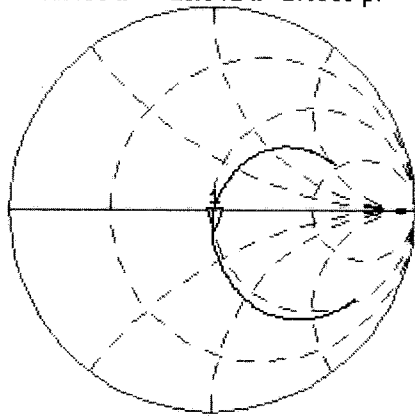

Avg
16
↑

CH2 S11 LOG 5 dB/REF -20 dB 1:-19.698 dB 900.000 000 MHz

Cor
Avg
16
↑

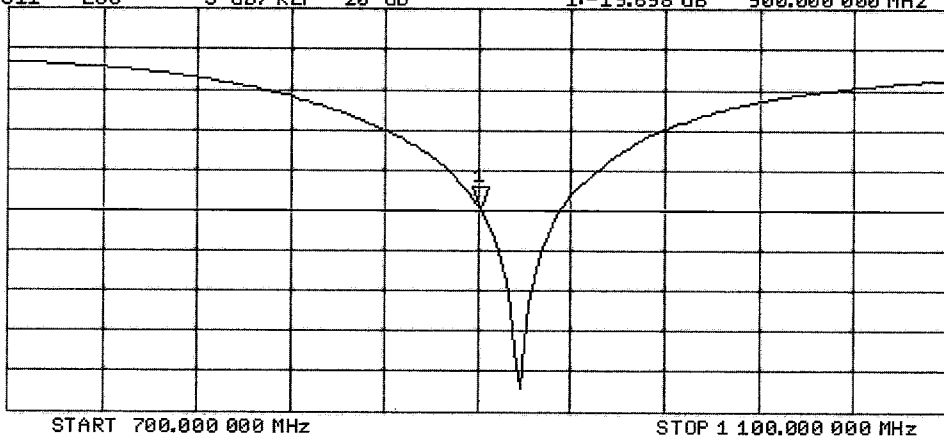

DASY5 Validation Report for Body

Date/Time: 17.08.2009 11:23:13

Test Laboratory: SPEAG, Zurich, Switzerland

DUT: Dipole 900 MHz; Type: D900V2; Serial: D900V2 - SN:185

Communication System: CW-900; Frequency: 900 MHz; Duty Cycle: 1:1

Medium: MSL900

Medium parameters used: $f = 900$ MHz; $\sigma = 1.06$ mho/m; $\epsilon_r = 52.7$; $\rho = 1000$ kg/m³

Phantom section: Flat Section

Measurement Standard: DASY5 (IEEE/IEC)

DASY5 Configuration:

- Probe: ES3DV3 - SN3205; ConvF(5.81, 5.81, 5.81); Calibrated: 26.06.2009
- Sensor-Surface: 3mm (Mechanical Surface Detection)
- Electronics: DAE4 Sn601; Calibrated: 07.03.2009
- Phantom: Flat Phantom 4.9L; Type: QD000P49AA; Serial: 1001
- Measurement SW: DASY5, V5.0 Build 120; SEMCAD X Version 13.4 Build 45

Pin=250mW; dip=15mm/Zoom Scan (7x7x7)/Cube 0: Measurement grid: dx=5mm, dy=5mm, dz=5mm

Reference Value = 57.2 V/m; Power Drift = 0.00569 dB

Peak SAR (extrapolated) = 4.19 W/kg

SAR(1 g) = 2.8 mW/g; SAR(10 g) = 1.81 mW/g

Maximum value of SAR (measured) = 3.24 mW/g

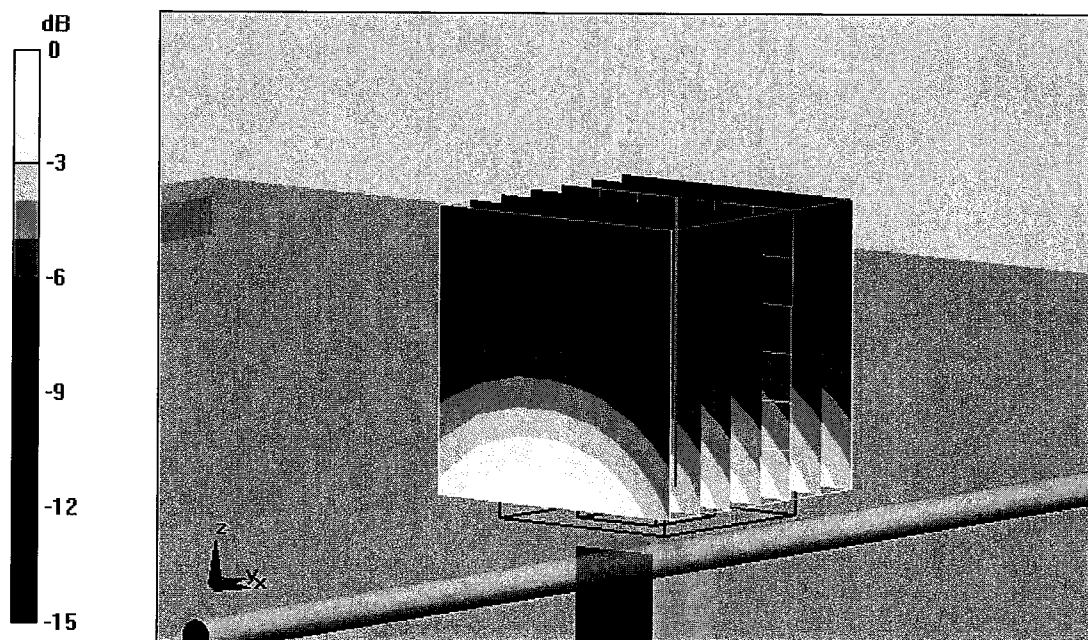

0 dB = 3.24mW/g

Impedance Measurement Plot for Body TSL

17 Aug 2009 08:58:55

CH1 S11 1 U FS 2: 45.471 Ω -11.215 Ω 15.768 pF 900.000 000 MHz

*
De1
Cor
Avg
16

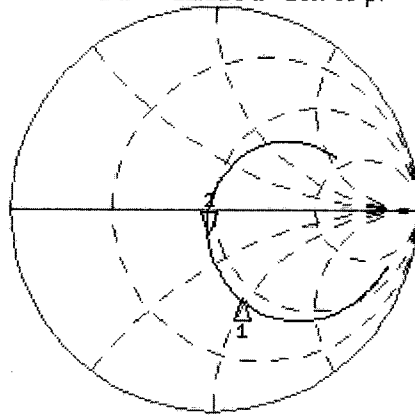

CH1 Markers
1: 41.352 Ω
-46.815 Ω
835.000 MHz

CH2 S11 LOG 5 dB/REF -20 dB 2: -18.006 dB 900.000 000 MHz

Cor
Avg
16

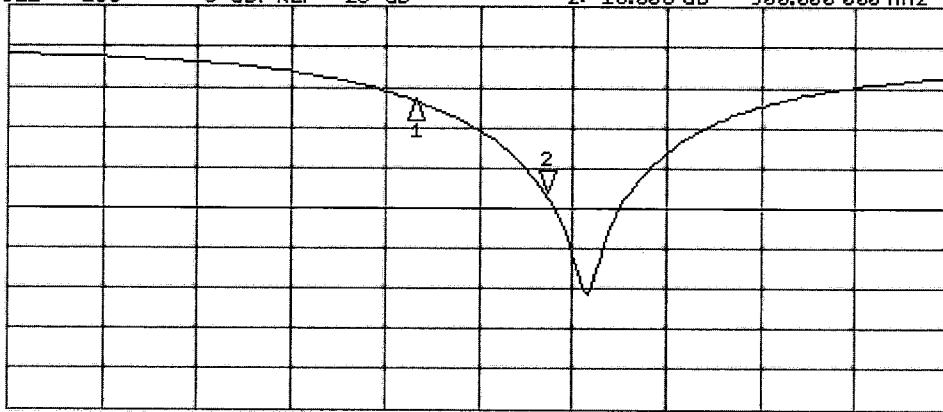

CH2 Markers
1: -5.6738 dB
835.000 MHz



A 1237
checked on 01/07/2009
S
C
S
Schweizerischer Kalibrierdienst
Service suisse d'étalonnage
Servizio svizzero di taratura
Swiss Calibration Service *by [Signature]*

Accredited by the Swiss Accreditation Service (SAS)
The Swiss Accreditation Service is one of the signatories to the EA
Multilateral Agreement for the recognition of calibration certificates

Accreditation No.: **SCS 108**

Client **RFI**

Certificate No: **D1900V2-540-Jun09**

CALIBRATION CERTIFICATE

Object **D1900V2 - SN: 540**

Calibration procedure(s) **QA CAL-05.v7
Calibration procedure for dipole validation kits**

Calibration date: **June 26, 2009**

Condition of the calibrated item **In Tolerance**

This calibration certificate documents the traceability to national standards, which realize the physical units of measurements (SI).
The measurements and the uncertainties with confidence probability are given on the following pages and are part of the certificate.

All calibrations have been conducted in the closed laboratory facility: environment temperature (22 ± 3)°C and humidity < 70%.

Calibration Equipment used (M&TE critical for calibration)

Primary Standards	ID #	Cal Date (Calibrated by, Certificate No.)	Scheduled Calibration
Power meter EPM-442A	GB37480704	08-Oct-08 (No. 217-00898)	Oct-09
Power sensor HP 8481A	US37292783	08-Oct-08 (No. 217-00898)	Oct-09
Reference 20 dB Attenuator	SN: 5086 (20g)	31-Mar-09 (No. 217-01025)	Mar-10
Type-N mismatch combination	SN: 5047.2 / 06327	31-Mar-09 (No. 217-01029)	Mar-10
Reference Probe ES3DV2	SN: 3025	30-Apr-09 (No. ES3-3025_Apr09)	Apr-10
DAE4	SN: 601	07-Mar-09 (No. DAE4-601_Mar09)	Mar-10
Secondary Standards	ID #	Check Date (in house)	Scheduled Check
Power sensor HP 8481A	MY41092317	18-Oct-02 (in house check Oct-07)	In house check: Oct-09
RF generator R&S SMT-06	100005	4-Aug-99 (in house check Oct-07)	In house check: Oct-09
Network Analyzer HP 8753E	US37390585 S4206	18-Oct-01 (in house check Oct-08)	In house check: Oct-09

Calibrated by: **Jeton Kastrati** (Name), **Laboratory Technician** (Function), *[Signature]* (Signature)

Approved by: **Katja Pokovic** (Name), **Technical Manager** (Function), *[Signature]* (Signature)

Issued: June 29, 2009

This calibration certificate shall not be reproduced except in full without written approval of the laboratory.



Accredited by the Swiss Accreditation Service (SAS)
The Swiss Accreditation Service is one of the signatories to the EA
Multilateral Agreement for the recognition of calibration certificates

Accreditation No.: **SCS 108**

Glossary:

TSL	tissue simulating liquid
ConvF	sensitivity in TSL / NORM x,y,z
N/A	not applicable or not measured

Calibration is Performed According to the Following Standards:

- IEEE Std 1528-2003, "IEEE Recommended Practice for Determining the Peak Spatial-Averaged Specific Absorption Rate (SAR) in the Human Head from Wireless Communications Devices: Measurement Techniques", December 2003
- CENELEC EN 50361, "Basic standard for the measurement of Specific Absorption Rate related to human exposure to electromagnetic fields from mobile phones (300 MHz - 3 GHz), July 2001
- Federal Communications Commission Office of Engineering & Technology (FCC OET), "Evaluating Compliance with FCC Guidelines for Human Exposure to Radiofrequency Electromagnetic Fields; Additional Information for Evaluating Compliance of Mobile and Portable Devices with FCC Limits for Human Exposure to Radiofrequency Emissions", Supplement C (Edition 01-01) to Bulletin 65

Additional Documentation:

- DASY4/5 System Handbook

Methods Applied and Interpretation of Parameters:

- Measurement Conditions:** Further details are available from the Validation Report at the end of the certificate. All figures stated in the certificate are valid at the frequency indicated.
- Antenna Parameters with TSL:** The dipole is mounted with the spacer to position its feed point exactly below the center marking of the flat phantom section, with the arms oriented parallel to the body axis.
- Feed Point Impedance and Return Loss:** These parameters are measured with the dipole positioned under the liquid filled phantom. The impedance stated is transformed from the measurement at the SMA connector to the feed point. The Return Loss ensures low reflected power. No uncertainty required.
- Electrical Delay:** One-way delay between the SMA connector and the antenna feed point. No uncertainty required.
- SAR measured:** SAR measured at the stated antenna input power.
- SAR normalized:** SAR as measured, normalized to an input power of 1 W at the antenna connector.
- SAR for nominal TSL parameters:** The measured TSL parameters are used to calculate the nominal SAR result.

Measurement Conditions

DASY system configuration, as far as not given on page 1.

DASY Version	DASY5	V5.0
Extrapolation	Advanced Extrapolation	
Phantom	Modular Flat Phantom V5.0	
Distance Dipole Center - TSL	10 mm	with Spacer
Zoom Scan Resolution	dx, dy, dz = 5 mm	
Frequency	1900 MHz \pm 1 MHz	

Head TSL parameters

The following parameters and calculations were applied.

	Temperature	Permittivity	Conductivity
Nominal Head TSL parameters	22.0 °C	40.0	1.40 mho/m
Measured Head TSL parameters	(22.0 \pm 0.2) °C	41.0 \pm 6 %	1.42 mho/m \pm 6 %
Head TSL temperature during test	(22.0 \pm 0.2) °C	---	---

SAR result with Head TSL

SAR averaged over 1 cm³ (1 g) of Head TSL	condition	
SAR measured	250 mW input power	10.1 mW / g
SAR normalized	normalized to 1W	40.4 mW / g
SAR for nominal Head TSL parameters ¹	normalized to 1W	40.3 mW / g \pm 17.0 % (k=2)

SAR averaged over 10 cm³ (10 g) of Head TSL	Condition	
SAR measured	250 mW input power	5.29 mW / g
SAR normalized	normalized to 1W	21.2 mW / g
SAR for nominal Head TSL parameters ¹	normalized to 1W	21.1 mW / g \pm 16.5 % (k=2)

¹ Correction to nominal TSL parameters according to d), chapter "SAR Sensitivities"

Body TSL parameters

The following parameters and calculations were applied.

	Temperature	Permittivity	Conductivity
Nominal Body TSL parameters	22.0 °C	53.3	1.52 mho/m
Measured Body TSL parameters	(22.0 ± 0.2) °C	53.9 ± 6 %	1.55 mho/m ± 6 %
Body TSL temperature during test	(21.2 ± 0.2) °C	---	---

SAR result with Body TSL

SAR averaged over 1 cm ³ (1 g) of Body TSL	Condition	
SAR measured	250 mW input power	10.3 mW / g
SAR normalized	normalized to 1W	41.2 mW / g
SAR for nominal Body TSL parameters ²	normalized to 1W	40.9 mW / g ± 17.0 % (k=2)

SAR averaged over 10 cm ³ (10 g) of Body TSL	condition	
SAR measured	250 mW input power	5.40 mW / g
SAR normalized	normalized to 1W	21.6 mW / g
SAR for nominal Body TSL parameters ²	normalized to 1W	21.5 mW / g ± 16.5 % (k=2)

² Correction to nominal TSL parameters according to d), chapter "SAR Sensitivities"

Appendix

Antenna Parameters with Head TSL

Impedance, transformed to feed point	$48.5 \Omega + 2.7 j\Omega$
Return Loss	- 30.0 dB

Antenna Parameters with Body TSL

Impedance, transformed to feed point	$44.9 \Omega + 2.8 j\Omega$
Return Loss	- 24.3 dB

General Antenna Parameters and Design

Electrical Delay (one direction)	1.198 ns

After long term use with 100W radiated power, only a slight warming of the dipole near the feedpoint can be measured.

The dipole is made of standard semirigid coaxial cable. The center conductor of the feeding line is directly connected to the second arm of the dipole. The antenna is therefore short-circuited for DC-signals.

No excessive force must be applied to the dipole arms, because they might bend or the soldered connections near the feedpoint may be damaged.

Additional EUT Data

Manufactured by	SPEAG
Manufactured on	July 26, 2001

DASY5 Validation Report for Head TSL

Date/Time: 26.06.2009 12:43:03

Test Laboratory: SPEAG, Zurich, Switzerland

DUT: Dipole 1900 MHz; Type: D1900V2; Serial: D1900V2 - SN:540

Communication System: CW; Frequency: 1900 MHz; Duty Cycle: 1:1

Medium: HSL U11 BB

Medium parameters used: $f = 1900$ MHz; $\sigma = 1.42$ mho/m; $\epsilon_r = 41$; $\rho = 1000$ kg/m³

Phantom section: Flat Section

Measurement Standard: DASY5 (IEEE/IEC)

DASY5 Configuration:

- Probe: ES3DV2 - SN3025; ConvF(4.88, 4.88, 4.88); Calibrated: 30.04.2009
- Sensor-Surface: 3mm (Mechanical Surface Detection)
- Electronics: DAE4 Sn601; Calibrated: 07.03.2009
- Phantom: Flat Phantom 5.0 (front); Type: QD000P50AA; Serial: 1001
- Measurement SW: DASY5, V5.0 Build 120; SEMCAD X Version 13.4 Build 45

Pin = 250 mW; dip = 10 mm/Zoom Scan (dist=3.0 mm, probe 0deg) (7x7x7)/Cube 0:

Measurement grid: dx=5mm, dy=5mm, dz=5mm

Reference Value = 96.9 V/m; Power Drift = 0.037 dB

Peak SAR (extrapolated) = 18.4 W/kg

SAR(1 g) = 10.1 mW/g; SAR(10 g) = 5.29 mW/g

Maximum value of SAR (measured) = 12.5 mW/g

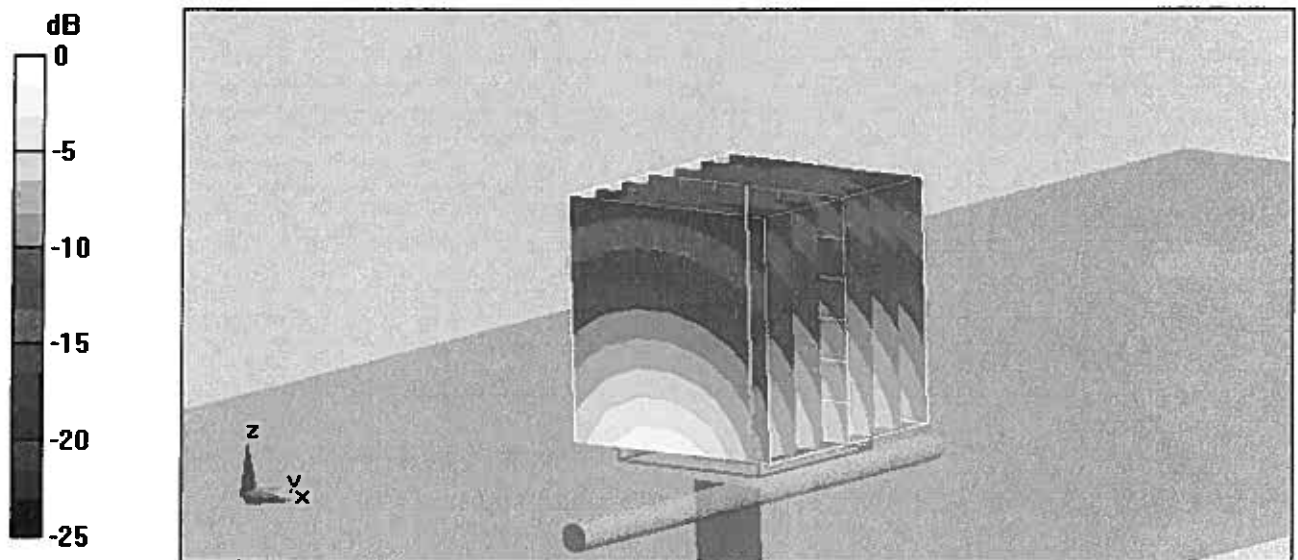

0 dB = 12.5mW/g

Impedance Measurement Plot for Head TSL

26 Jun 2009 08:28:31

CH1 S11 1 U FS 2: 48.482 Ω 2.7168 Ω 227.57 μH 1 900.000 000 MHz

*
Del
Cor

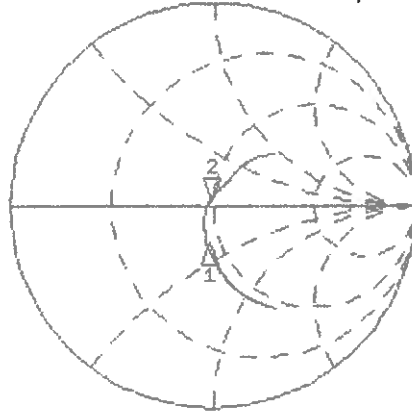

CH1 Markers
1: 48.922 Ω
-17.873 Ω
1.80000 GHz

Avg
16

↑

CH2 S11 LOG 5 dB/ REF -20 dB 2: -30.012 dB 1 900.000 000 MHz

Cor

Avg
16

↑

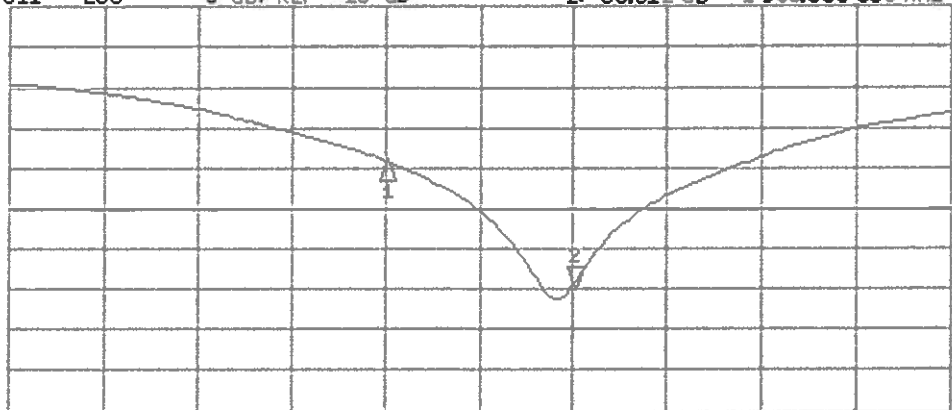

CH2 Markers
1: -14.091 dB
1.80000 GHz

START 1 600.000 000 MHz

STOP 2 100.000 000 MHz

DASY5 Validation Report for Body TSL

Date/Time: 26.06.2009 14:10:45

Test Laboratory: SPEAG, Zurich, Switzerland

DUT: Dipole 1900 MHz; Type: D1900V2; Serial: D1900V2 - SN:540

Communication System: CW; Frequency: 1900 MHz; Duty Cycle: 1:1

Medium: MSL U10 BB

Medium parameters used: $f = 1900$ MHz; $\sigma = 1.55$ mho/m; $\epsilon_r = 54$; $\rho = 1000$ kg/m³

Phantom section: Flat Section

Measurement Standard: DASY5 (IEEE/IEC)

DASY5 Configuration:

- Probe: ES3DV2 - SN3025; ConvF(4.46, 4.46, 4.46); Calibrated: 30.04.2009
- Sensor-Surface: 3mm (Mechanical Surface Detection)
- Electronics: DAE4 Sn601; Calibrated: 07.03.2009
- Phantom: Flat Phantom 5.0 (back); Type: QD000P50AA; Serial: 1002
- Measurement SW: DASY5, V5.0 Build 120; SEMCAD X Version 13.4 Build 45

Pin = 250 mW; dip = 10 mm/Zoom Scan (dist=3.0mm, probe 0deg) (7x7x7)/Cube 0:

Measurement grid: dx=5mm, dy=5mm, dz=5mm

Reference Value = 95.1 V/m; Power Drift = 0.011 dB

Peak SAR (extrapolated) = 18.1 W/kg

SAR(1 g) = 10.3 mW/g; SAR(10 g) = 5.4 mW/g

Maximum value of SAR (measured) = 12.9 mW/g

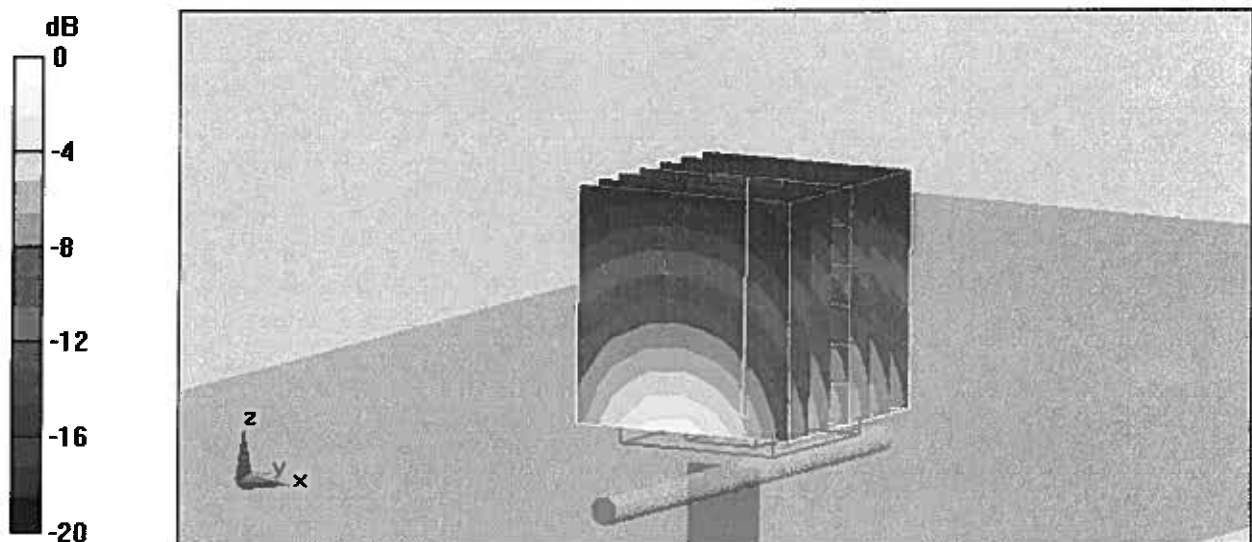

0 dB = 12.9mW/g

Impedance Measurement Plot for Body TSL

26 Jun 2009 08:29:09

CH1 S11 1 U FS 2: 44.900 Ω 2.7637 Ω 231.50 pF 1 900.000 000 MHz

*
Del
Cor

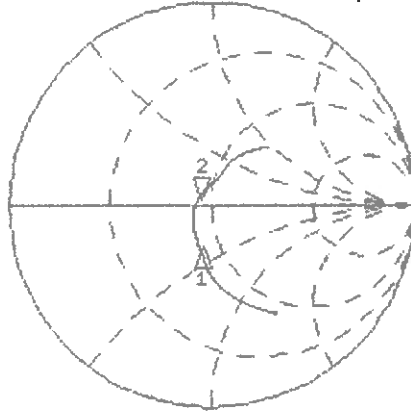

CH1 Markers
1: 41.766 Ω
-18.492 Ω
1.80000 GHz

Avg
16

↑

CH2 S11 LOG 5 dB/REF -20 dB 2: -24.278 dB 1 900.000 000 MHz

Cor

Avg
16

↑

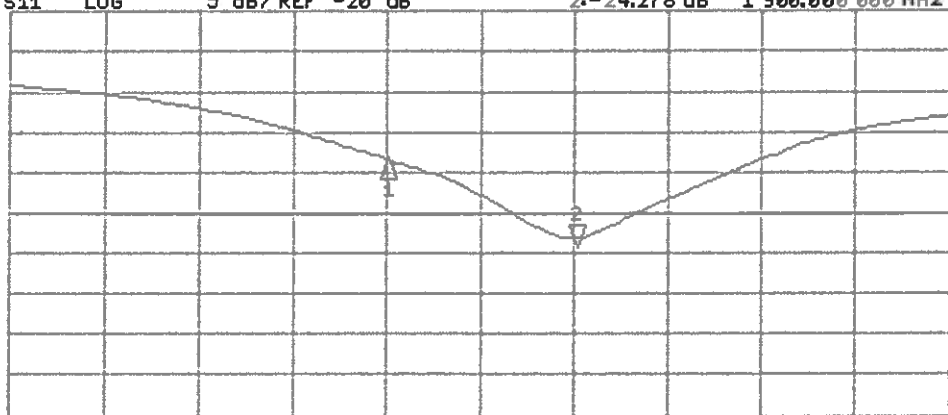

CH2 Markers
1: -13.300 dB
1.80000 GHz

START 1 600.000 000 MHz

STOP 2 100.000 000 MHz

Test of: Dell Latitude E4200 Notebook PC

To: OET Bulletin 65 Supplement C: (2001-01)

Appendix 2. Measurement Methods

A.2.1. Evaluation Procedure

The Specific Absorption Rate (SAR) evaluation was performed in the following manner:

- a) (i) The evaluation was performed in an applicable area of the phantom depending on the type of device being tested. For devices worn about the ear during normal operation, both the left and right ear positions were evaluated at the centre frequency of the band at maximum power. The side, which produced the greatest SAR, determined which side of the phantom would be used for the entire evaluation. The positioning of the head worn device relative to the phantom was dictated by the test specification identified in section 3.1 of this report.

(ii) For body worn devices or devices which can be operated within 20 cm of the body, the flat section of the SAM phantom was used were the size of the device(s) is normal. for bigger devices and base station the 2mm Oval phantom is used for evaluation. The type of device being evaluated dictated the distance of the EUT to the outer surface of the phantom flat section.
 - b) The SAR was determined by a pre-defined procedure within the DASY4 software. The exposed region of the phantom was scanned near the inner surface with a grid spacing of 20mm x 20mm or appropriate resolution.
 - c) A 5x5x7 matrix was performed around the greatest spatial SAR distribution found during the area scan of the applicable exposed region. SAR values were then calculated using a 3-D spline interpolation algorithm and averaged over spatial volumes of 1 and 10 grams.
 - d) If the EUT had any appreciable drift over the course of the evaluation, then the EUT was re-evaluated. Any unusual anomalies over the course of the test also warranted a re-evaluation.
-

Test of: Dell Latitude E4200 Notebook PC

To: OET Bulletin 65 Supplement C: (2001-01)

A.2.2. Specific Absorption Rate (SAR) Measurements to OET Bulletin 65 Supplement C: (2001-01)

Evaluating Compliance with FCC Guidelines for Human Exposure to Radio Frequency Electromagnetic Fields

SAR measurements were performed in accordance with Appendix D of the standard FCC OET Bulletin 65 Supplement C: 2001, against appropriate limits for each measurement position in accordance with the standard.

The test was performed in a shielded enclosure with the temperature controlled to remain between +18.0°C and +25.0°C. The tissue equivalent material fluid temperature was controlled to give a maximum variation of $\pm 2.0^\circ\text{C}$

Prior to any SAR measurements on the EUT, system validation and material dielectric property measurements were conducted. In the absence of a detailed procedure within the specification, system validation and material dielectric property measurements were performed in accordance with Appendix C and Appendix D of FCC OET Bulletin 65 Supplement C: 2001.

Following the successful system validation and material dielectric property measurements, a SAR versus time sweep shall be performed within 10 mm of the phantom inner surface. If the EUT power output is stable after three minutes then the measurement probe will perform a coarse surface level scan at each test position in order to ascertain the location of the maximum local SAR level. Once this area had been established, a 5x5x7 cube of 175 points (5 mm spacing in each axis $\approx 27\text{g}$) will be centred at the area of concern. Extrapolation and interpolation will then be carried out on the 27g of tissue and the highest averaged SAR over a 10g cube determined.

Once the maximum interpolated SAR measurement is complete; the coarse scan is visually assessed to check for secondary peaks within 50% of the maximum SAR level. If there are any further SAR measurements required, extra 5x5x7 cubes shall be centred on each of these extra local SAR maxima.

At the end of each position test case a second time sweep shall be performed to check whether the EUT has remained stable throughout the test.

Test of: Dell Latitude E4200 Notebook PC

To: OET Bulletin 65 Supplement C: (2001-01)

Appendix 3. SAR Distribution Scans

This appendix contains SAR distribution scans which are not included in the total number of pages for this report.

Scan Reference Number	Title
SCN/75978JD11/001	Base of EUT Facing Phantom GPRS CH189
SCN/75978JD11/002	Base of EUT Facing Phantom EGPRS CH189
SCN/75978JD11/003	Base of EUT SKU-900 Facing Phantom GPRS CH189
SCN/75978JD11/004	Base of EUT Facing Phantom FDD V CH4183
SCN/75978JD11/005	Base of EUT Facing Phantom FDD V + HSDPA CH4183
SCN/75978JD11/006	Base of EUT Facing Phantom FDD V + HSPA CH4183
SCN/75978JD11/007	Base of EUT Facing Phantom GPRS CH660
SCN/75978JD11/008	Base of EUT Facing Phantom EGPRS CH660
SCN/75978JD11/009	Base of EUT SKU-900 Facing Phantom EGPRS CH660
SCN/75978JD11/010	Base of EUT Facing Phantom FDD II CH9400
SCN/75978JD11/011	Base of EUT Facing Phantom FDD II + HSDPA CH9400
SCN/75978JD11/012	Base of EUT Facing Phantom FDD II + HSPA CH9400
SCN/75978JD11/013	Base of EUT SKU-900 Facing Phantom FDD II CH9400
SCN/75978JD11/014	System Performance Check 1900MHz Body 17 09 09
SCN/75978JD11/015	System Performance Check 1900MHz Body 18 09 09
SCN/75978JD11/016	System Performance Check 1900MHz Body 25 09 09
SCN/75978JD11/017	System Performance Check 1900MHz Body 28 09 09
SCN/75978JD11/018	System Performance Check 900MHz Body 28 09 09
SCN/75978JD11/019	System Performance Check 900MHz Body 29 09 09
SCN/75978JD11/020	System Performance Check 900MHz Body 30 09 09
SCN/75978JD11/021	System Performance Check 1900MHz Body 30 09 09
SCN/75978JD11/022	System Performance Check 1900MHz Body 01 10 09

Test of: Dell Latitude E4200 Notebook PC

To: OET Bulletin 65 Supplement C: (2001-01)

SCN/75978JD11/001: Base of EUT Facing Phantom GPRS CH189

Date 28/09/2009

DUT: DELL Mini Cooper CAM H2; Type: LATITUDE E4200; Serial: 00440100304320

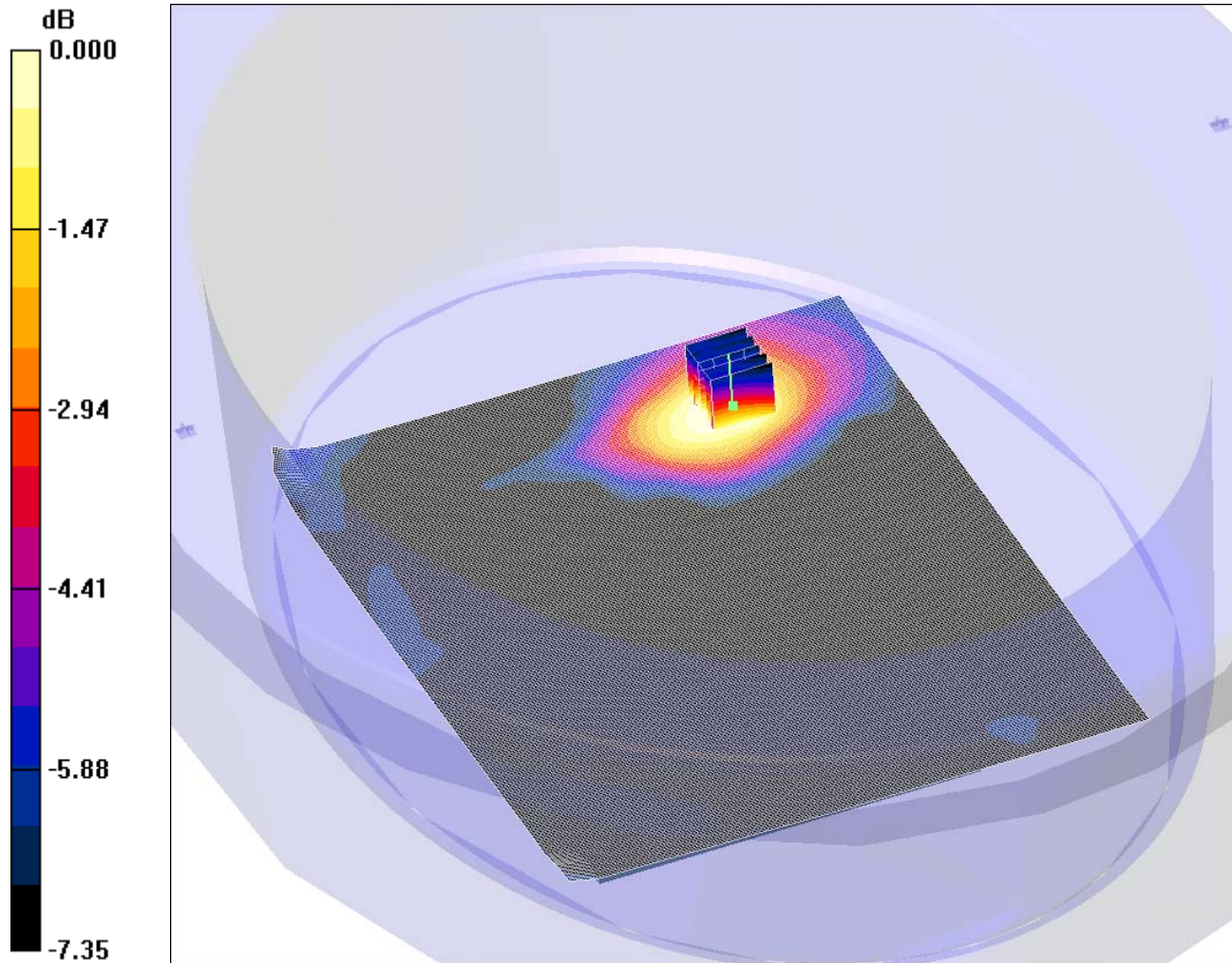

0 dB = 0.055mW/g

Communication System: GPRS 850 MHz; Frequency: 836.4 MHz; Duty Cycle: 1:4

Medium: 900 MHz MSL Medium parameters used (interpolated): $f = 836.4$ MHz; $\sigma = 0.968$ mho/m; $\epsilon_r = 53.8$; $\rho = 1000$ kg/m³

Phantom section: basin Section

DASY4 Configuration:

- Probe: EX3DV3 - SN3508; ConvF(9.99, 9.99, 9.99); Calibrated: 26/06/2009

- Sensor-Surface: 4mm (Mechanical Surface Detection)

- Electronics: DAE3 Sn450; Calibrated: 30/04/2009

- Phantom: basin; Type: 3mm; Serial: **Not Specified**

- Measurement SW: DASY4, V4.7 Build 55; Postprocessing SW: SEMCAD, V1.8 Build 176

Base of EUT Facing Phantom - Middle/Area Scan (201x261x1): Measurement grid: dx=15mm, dy=15mm

Maximum value of SAR (interpolated) = 0.057 mW/g

Base of EUT Facing Phantom - Middle/Zoom Scan (5x5x7) (5x5x7)/Cube 0: Measurement grid: dx=8mm, dy=8mm, dz=5mm

Reference Value = 2.87 V/m; Power Drift = 0.369 dB

Peak SAR (extrapolated) = 0.070 W/kg

SAR(1 g) = 0.053 mW/g; SAR(10 g) = 0.039 mW/g

Maximum value of SAR (measured) = 0.055 mW/g

Test of: Dell Latitude E4200 Notebook PC

To: OET Bulletin 65 Supplement C: (2001-01)

SCN/75978JD11/002: Base of EUT Facing Phantom EGPRS CH189

Date 29/09/2009

DUT: DELL Mini Cooper CAM H2; Type: LATITUDE E4200; Serial: 00440100304320

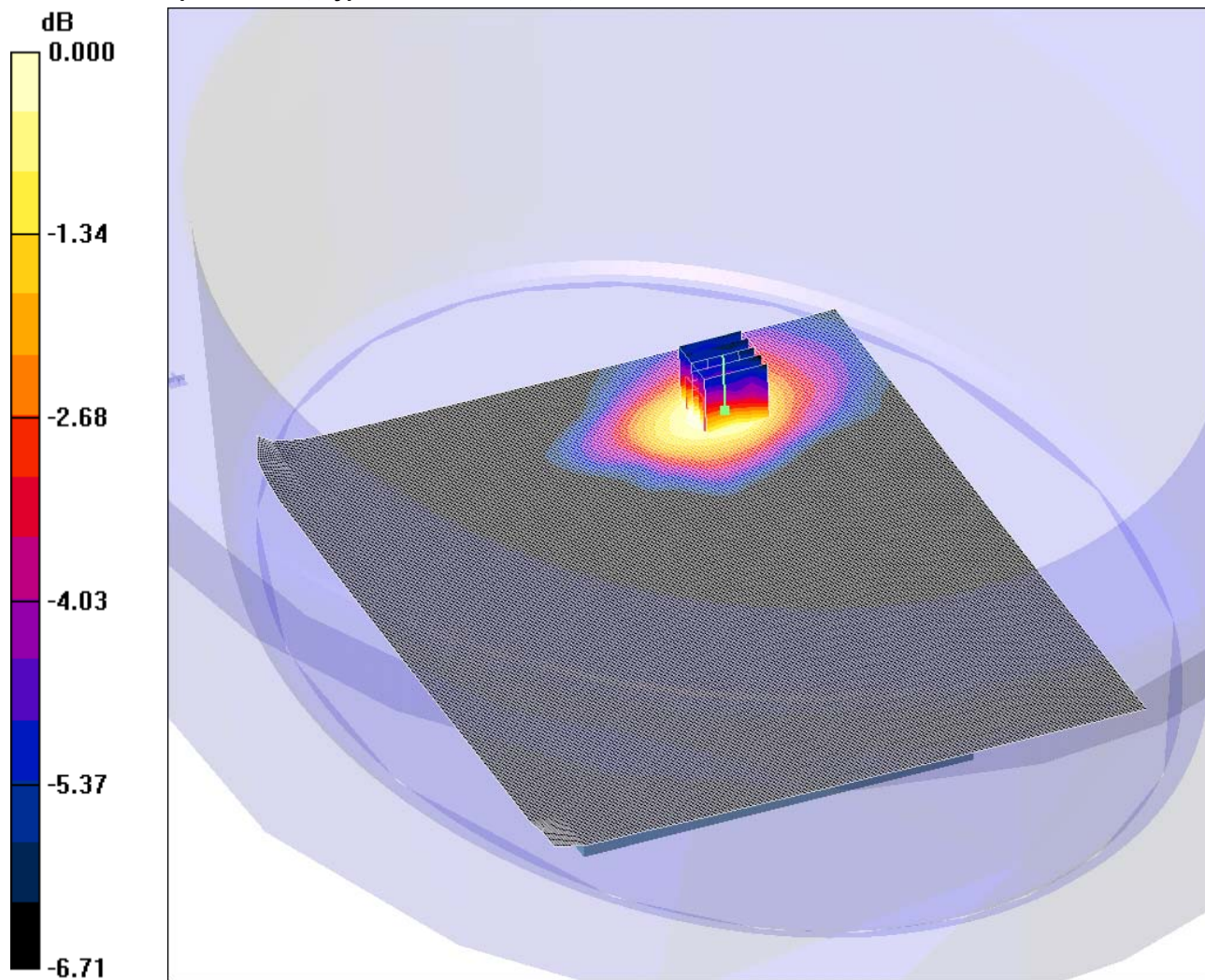

0 dB = 0.039mW/g

Communication System: EGPRS 850 MHz; Frequency: 836.4 MHz; Duty Cycle: 1:4

Medium: 900 MHz MSL Medium parameters used (interpolated): $f = 836.4$ MHz; $\sigma = 0.968$ mho/m; $\epsilon_r = 53.8$; $\rho = 1000$ kg/m³

Phantom section: basin Section

DASY4 Configuration:

- Probe: EX3DV3 - SN3508; ConvF(9.99, 9.99, 9.99); Calibrated: 26/06/2009

- Sensor-Surface: 4mm (Mechanical Surface Detection)

- Electronics: DAE3 Sn450; Calibrated: 30/04/2009

- Phantom: basin; Type: 3mm; Serial: **Not Specified**

- Measurement SW: DASY4, V4.7 Build 55; Postprocessing SW: SEMCAD, V1.8 Build 176

Base of EUT Facing Phantom - Middle /Area Scan (201x261x1): Measurement grid: dx=15mm, dy=15mm

Maximum value of SAR (interpolated) = 0.040 mW/g

Base of EUT Facing Phantom - Middle /Zoom Scan (5x5x7) (5x5x7)/Cube 0: Measurement grid: dx=8mm, dy=8mm, dz=5mm

Reference Value = 2.02 V/m; Power Drift = 0.381 dB

Peak SAR (extrapolated) = 0.050 W/kg

SAR(1 g) = 0.038 mW/g; SAR(10 g) = 0.028 mW/g

Maximum value of SAR (measured) = 0.039 mW/g

Test of: Dell Latitude E4200 Notebook PC

To: OET Bulletin 65 Supplement C: (2001-01)

SCN/75978JD11/003: Base of EUT SKU-900 Facing Phantom GPRS CH189

Date 30/09/2009

DUT: DELL Mini Cooper CAM H2; Type: LATITUDE E4200; Serial: 00440100304320

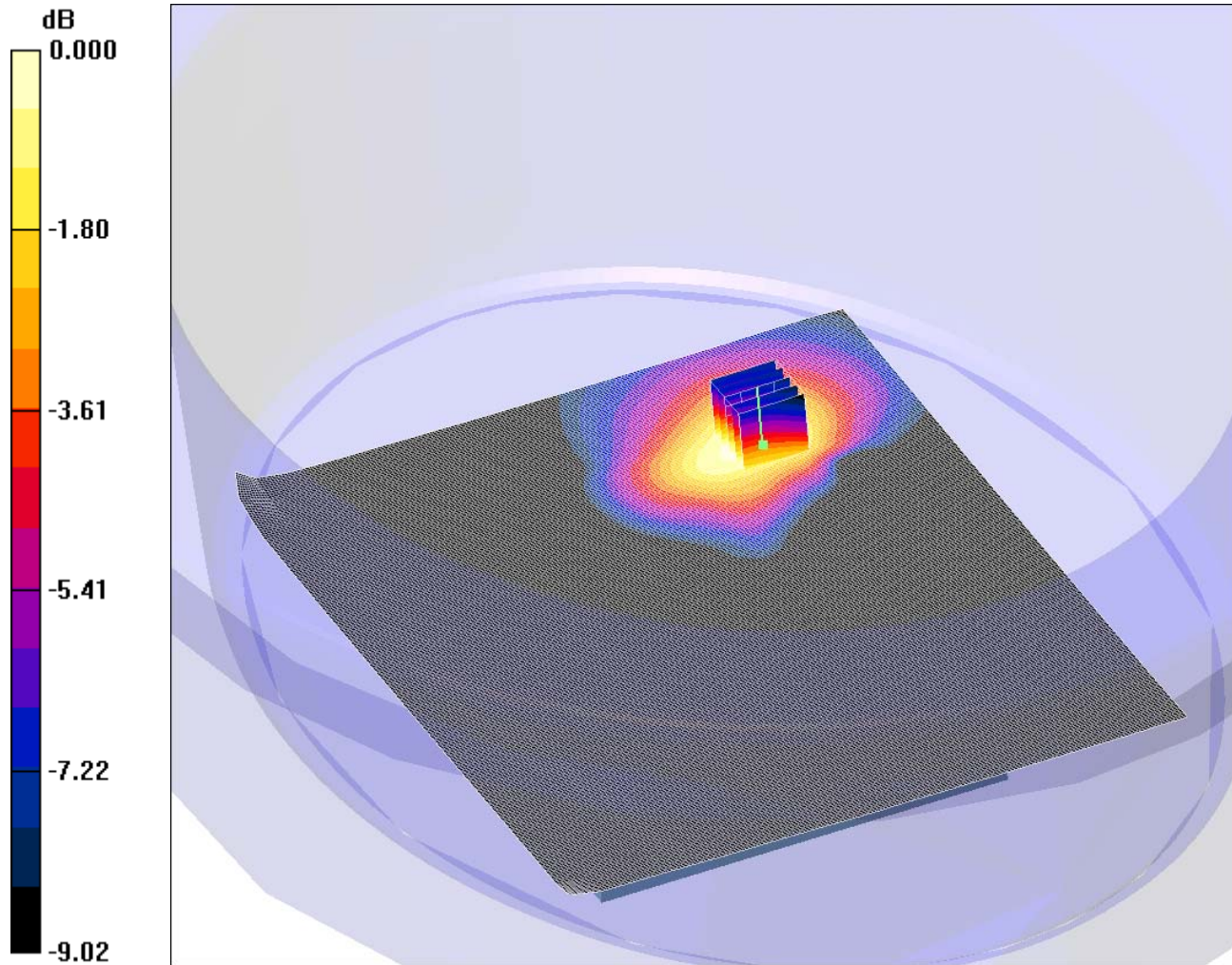

0 dB = 0.144mW/g

Communication System: GPRS 850 MHz; Frequency: 836.4 MHz; Duty Cycle: 1:4

Medium: 900 MHz MSL Medium parameters used (interpolated): $f = 836.4$ MHz; $\sigma = 0.959$ mho/m; $\epsilon_r = 54.1$; $\rho = 1000$ kg/m³

Phantom section: basin Section

DASY4 Configuration:

- Probe: EX3DV3 - SN3508; ConvF(9.99, 9.99, 9.99); Calibrated: 26/06/2009

- Sensor-Surface: 4mm (Mechanical Surface Detection)

- Electronics: DAE3 Sn450; Calibrated: 30/04/2009

- Phantom: basin; Type: 3mm; Serial: **Not Specified**

- Measurement SW: DASY4, V4.7 Build 55; Postprocessing SW: SEMCAD, V1.8 Build 176

Base of EUT Facing Phantom - Middle/Area Scan (201x261x1): Measurement grid: dx=15mm, dy=15mm

Maximum value of SAR (interpolated) = 0.148 mW/g

Base of EUT Facing Phantom - Middle/Zoom Scan (5x5x7) (5x5x7)/Cube 0: Measurement grid: dx=8mm, dy=8mm, dz=5mm

Reference Value = 2.28 V/m; Power Drift = 0.354 dB

Peak SAR (extrapolated) = 0.184 W/kg

SAR(1 g) = 0.137 mW/g; SAR(10 g) = 0.100 mW/g

Maximum value of SAR (measured) = 0.144 mW/g

Test of: Dell Latitude E4200 Notebook PC

To: OET Bulletin 65 Supplement C: (2001-01)

SCN/75978JD11/004: Base of EUT Facing Phantom FDD V CH4183

Date 29/09/2009

DUT: DELL Mini Cooper CAM H2; Type: LATITUDE E4200; Serial: 00440100304320

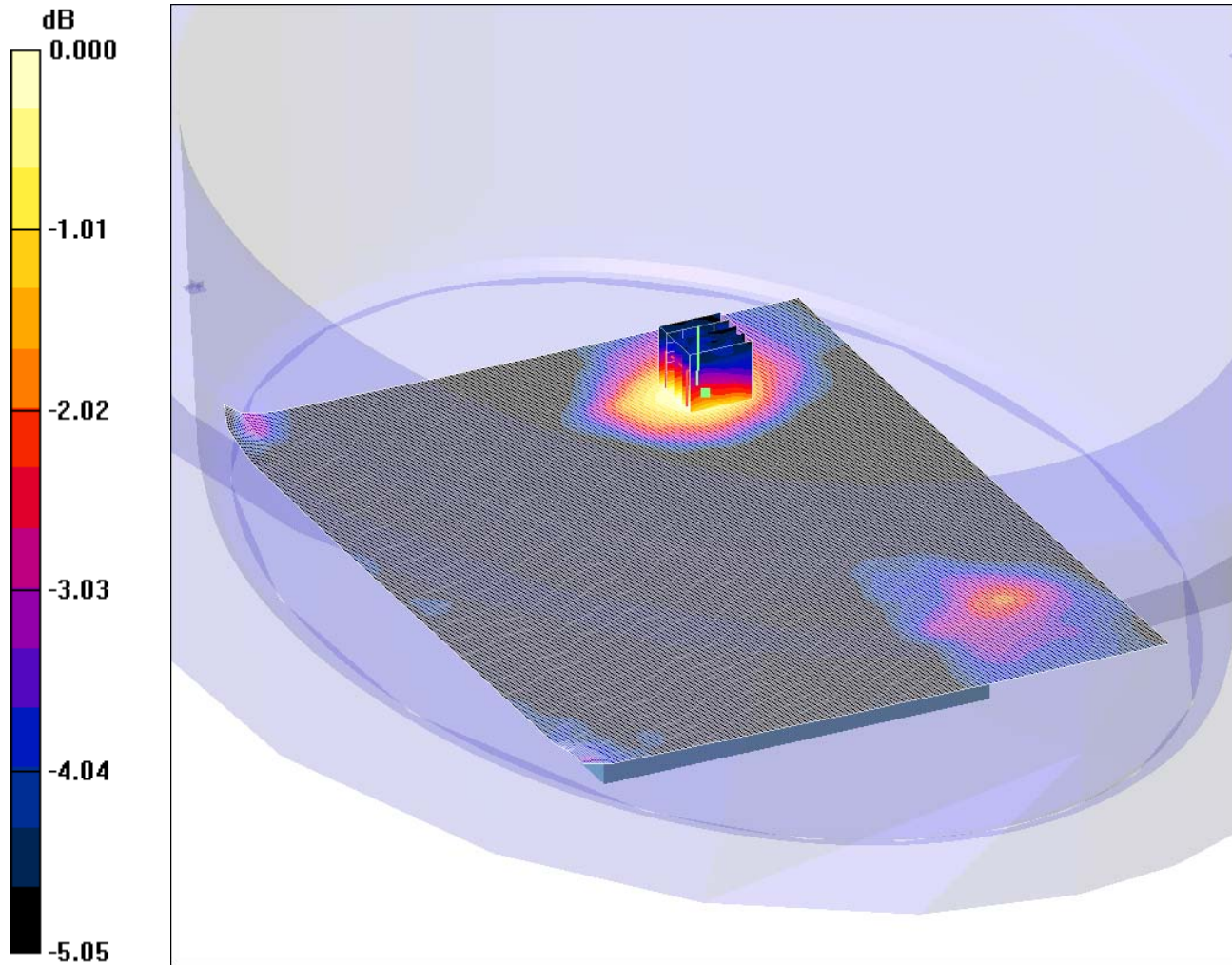

0 dB = 0.021mW/g

Communication System: UMTS-FDD V; Frequency: 836.6 MHz; Duty Cycle: 1:1

Medium: 900 MHz MSL Medium parameters used (interpolated): $f = 836.6$ MHz; $\sigma = 0.968$ mho/m; $\epsilon_r = 53.7$; $\rho = 1000$ kg/m³

Phantom section: basin Section

DASY4 Configuration:

- Probe: EX3DV3 - SN3508; ConvF(9.99, 9.99, 9.99); Calibrated: 26/06/2009

- Sensor-Surface: 4mm (Mechanical Surface Detection)

- Electronics: DAE3 Sn450; Calibrated: 30/04/2009

- Phantom: basin; Type: 3mm; Serial: **Not Specified**

- Measurement SW: DASY4, V4.7 Build 55; Postprocessing SW: SEMCAD, V1.8 Build 176

Base of EUT Facing Phantom - Middle/Area Scan (201x261x1): Measurement grid: dx=15mm, dy=15mm

Maximum value of SAR (interpolated) = 0.021 mW/g

Base of EUT Facing Phantom - Middle/Zoom Scan (5x5x7) (5x5x7)/Cube 0: Measurement grid: dx=8mm, dy=8mm, dz=5mm

Reference Value = 2.54 V/m; Power Drift = 0.126 dB

Peak SAR (extrapolated) = 0.029 W/kg

SAR(1 g) = 0.020 mW/g; SAR(10 g) = 0.016 mW/g

Maximum value of SAR (measured) = 0.021 mW/g

Test of: Dell Latitude E4200 Notebook PC

To: OET Bulletin 65 Supplement C: (2001-01)

SCN/75978JD11/005: Base of EUT Facing Phantom FDD V + HSDPA CH4183

Date 30/09/2009

DUT: DELL Mini Cooper CAM H2; Type: LATITUDE E4200; Serial: 00440100304320

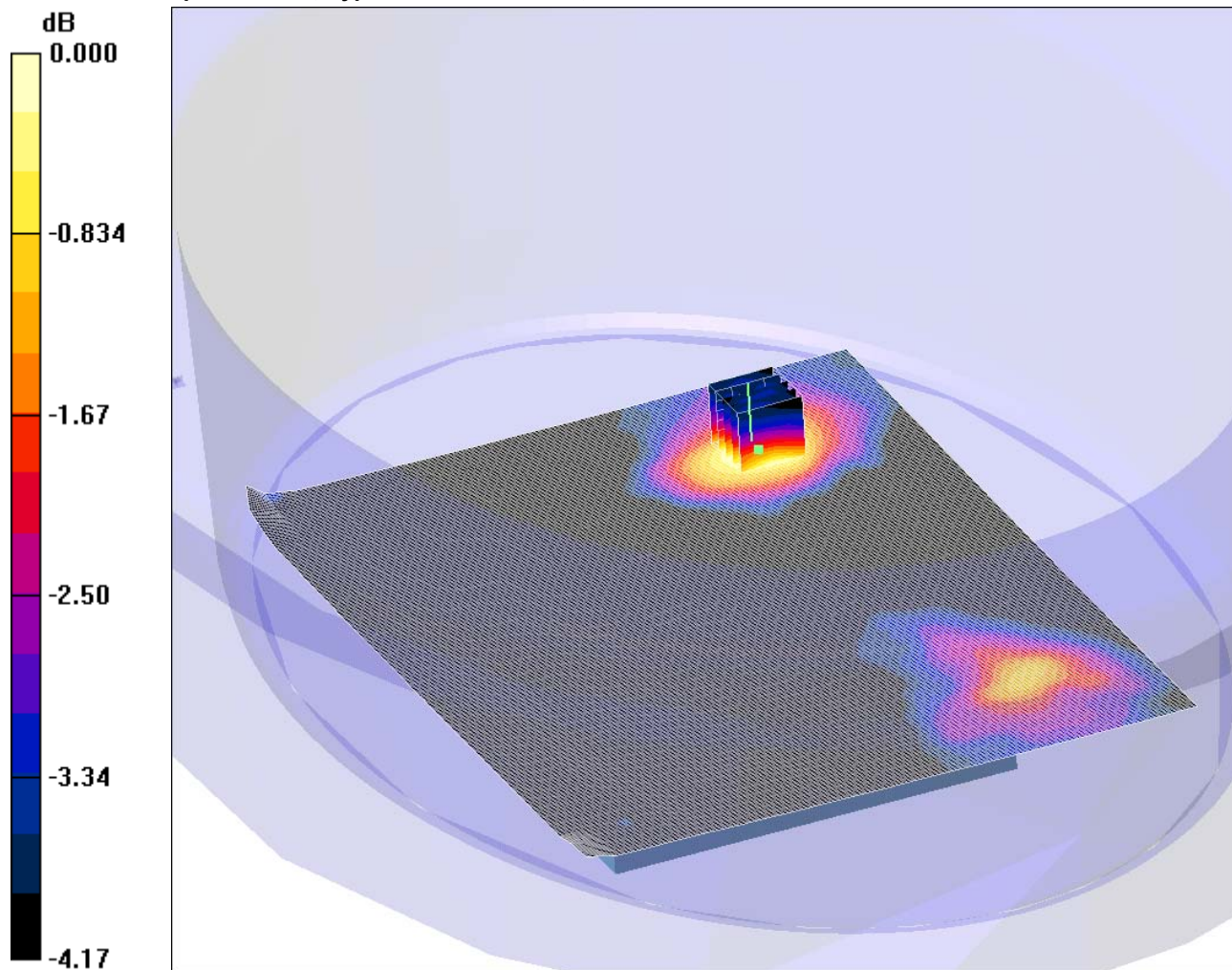

0 dB = 0.019mW/g

Communication System: UMTS-FDD V; Frequency: 836.6 MHz; Duty Cycle: 1:1

Medium: 900 MHz MSL Medium parameters used (interpolated): $f = 836.6$ MHz; $\sigma = 0.959$ mho/m; $\epsilon_r = 54.1$; $\rho = 1000$ kg/m³

Phantom section: basin Section

DASY4 Configuration:

- Probe: EX3DV3 - SN3508; ConvF(9.99, 9.99, 9.99); Calibrated: 26/06/2009

- Sensor-Surface: 4mm (Mechanical Surface Detection)

- Electronics: DAE3 Sn450; Calibrated: 30/04/2009

- Phantom: basin; Type: 3mm; Serial: **Not Specified**

- Measurement SW: DASY4, V4.7 Build 55; Postprocessing SW: SEMCAD, V1.8 Build 176

Base of EUT Facing Phantom - Middle /Area Scan (201x261x1): Measurement grid: dx=15mm, dy=15mm

Maximum value of SAR (interpolated) = 0.019 mW/g

Base of EUT Facing Phantom - Middle /Zoom Scan (5x5x7) (5x5x7)/Cube 0: Measurement grid: dx=8mm, dy=8mm, dz=5mm

Reference Value = 2.28 V/m; Power Drift = 0.294 dB

Peak SAR (extrapolated) = 0.023 W/kg

SAR(1 g) = 0.019 mW/g; SAR(10 g) = 0.015 mW/g

Maximum value of SAR (measured) = 0.019 mW/g

Test of: Dell Latitude E4200 Notebook PC

To: OET Bulletin 65 Supplement C: (2001-01)

SCN/75978JD11/006: Base of EUT Facing Phantom FDD V + HSPA CH4183

Date 29/09/2009

DUT: DELL Mini Cooper CAM H2; Type: LATITUDE E4200; Serial: 00440100304320

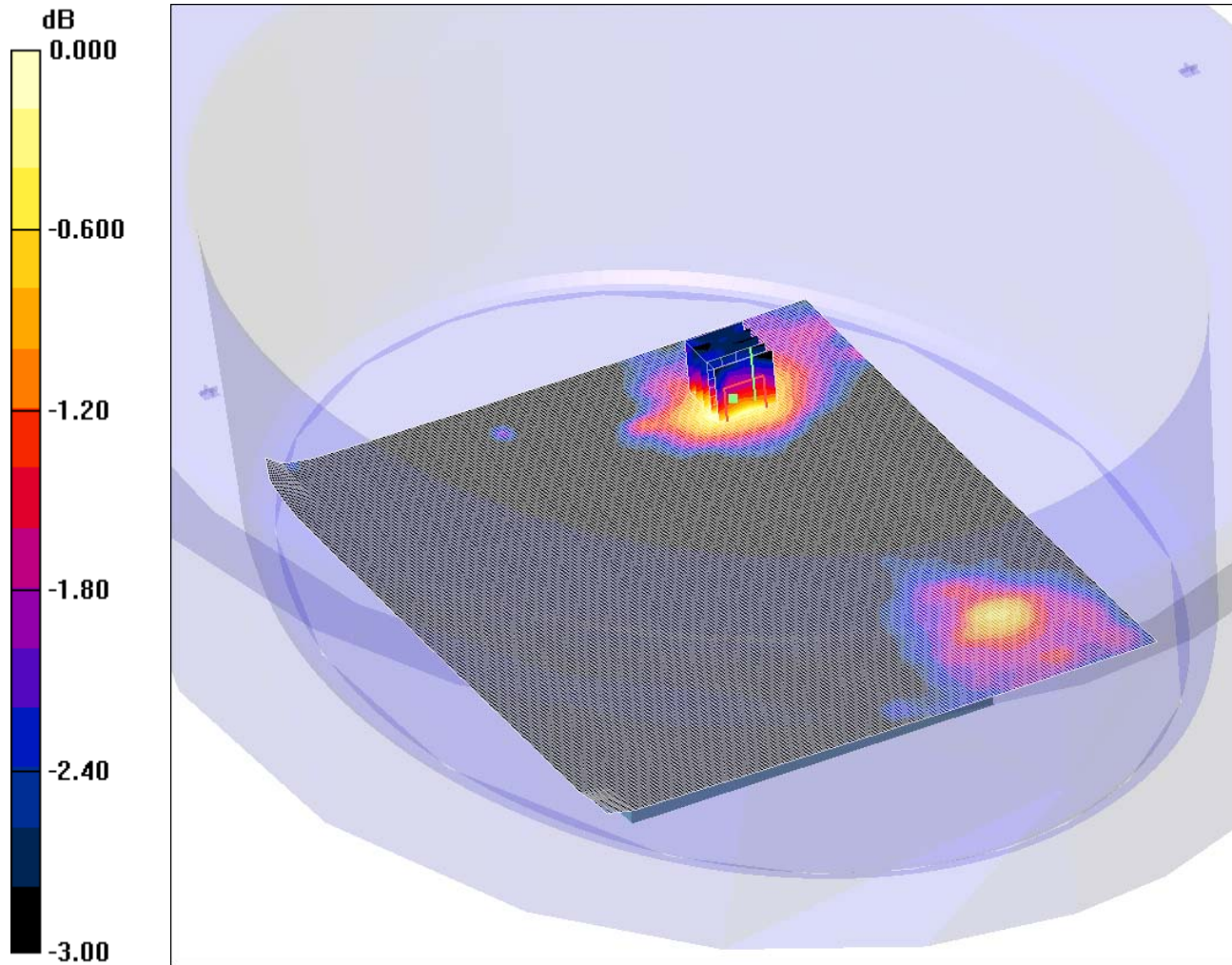

0 dB = 0.011mW/g

Communication System: UMTS-FDD V; Frequency: 836.6 MHz; Duty Cycle: 1:1

Medium: 900 MHz MSL Medium parameters used (interpolated): $f = 836.6$ MHz; $\sigma = 0.968$ mho/m; $\epsilon_r = 53.7$; $\rho = 1000$ kg/m³

Phantom section: basin Section

DASY4 Configuration:

- Probe: EX3DV3 - SN3508; ConvF(9.99, 9.99, 9.99); Calibrated: 26/06/2009

- Sensor-Surface: 4mm (Mechanical Surface Detection)

- Electronics: DAE3 Sn450; Calibrated: 30/04/2009

- Phantom: basin; Type: 3mm; Serial: **Not Specified**

- Measurement SW: DASY4, V4.7 Build 55; Postprocessing SW: SEMCAD, V1.8 Build 176

Base of EUT Facing Phantom - Middle /Area Scan (201x261x1): Measurement grid: dx=15mm, dy=15mm

Maximum value of SAR (interpolated) = 0.011 mW/g

Base of EUT Facing Phantom - Middle /Zoom Scan (5x5x7) (5x5x7)/Cube 0: Measurement grid: dx=8mm, dy=8mm, dz=5mm

Reference Value = 2.04 V/m; Power Drift = -0.155 dB

Peak SAR (extrapolated) = 0.014 W/kg

SAR(1 g) = 0.011 mW/g; SAR(10 g) = 0.00911 mW/g

Maximum value of SAR (measured) = 0.011 mW/g

Test of: Dell Latitude E4200 Notebook PC

To: OET Bulletin 65 Supplement C: (2001-01)

SCN/75978JD11/007: Base of EUT Facing Phantom GPRS CH660

Date 18/09/2009

DUT: DELL Mini Cooper CAM H2; Type: LATITUDE E4200; Serial: 00440100304320

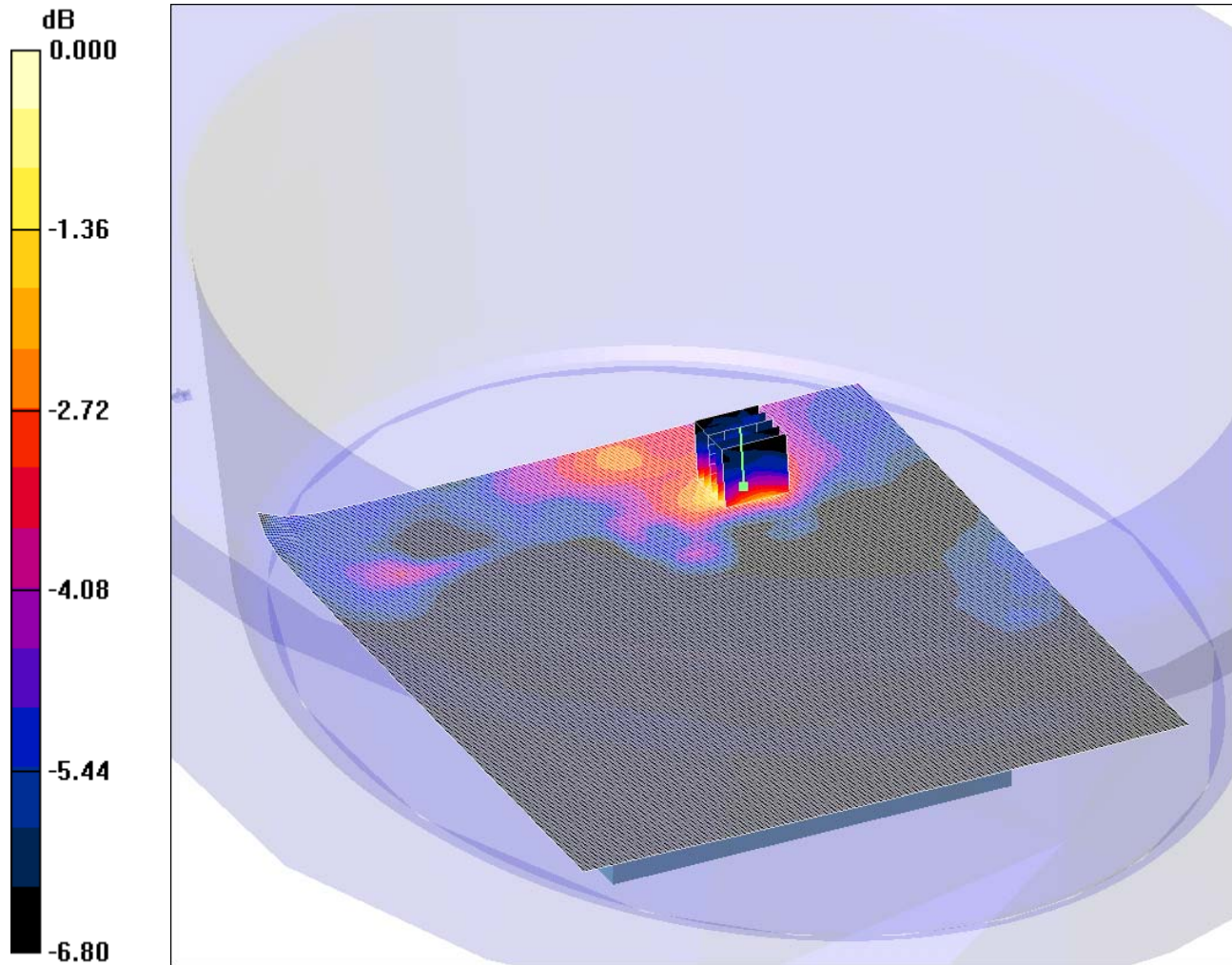

Communication System: GPRS 1900; Frequency: 1879.8 MHz; Duty Cycle: 1:4

Medium: 1900 MHz MSL Medium parameters used (interpolated): $f = 1879.8$ MHz; $\sigma = 1.56$ mho/m; $\epsilon_r = 53.5$; $\rho = 1000$ kg/m³

Phantom section: basin Section

DASY4 Configuration:

- Probe: EX3DV3 - SN3508; ConvF(8.23, 8.23, 8.23); Calibrated: 26/06/2009

- Sensor-Surface: 4mm (Mechanical Surface Detection)

- Electronics: DAE3 Sn450; Calibrated: 30/04/2009

- Phantom: basin; Type: 3mm; Serial: **Not Specified**

- Measurement SW: DASY4, V4.7 Build 55; Postprocessing SW: SEMCAD, V1.8 Build 176

Base of EUT Facing Phantom - Middle /Area Scan (201x261x1): Measurement grid: dx=15mm, dy=15mm

Maximum value of SAR (interpolated) = 0.051 mW/g

Base of EUT Facing Phantom - Middle /Zoom Scan (5x5x7) (5x5x7)/Cube 0: Measurement grid: dx=8mm, dy=8mm, dz=5mm

Reference Value = 1.99 V/m; Power Drift = 0.459 dB

Peak SAR (extrapolated) = 0.067 W/kg

SAR(1 g) = 0.047 mW/g; SAR(10 g) = 0.032 mW/g

Maximum value of SAR (measured) = 0.049 mW/g

Test of: Dell Latitude E4200 Notebook PC

To: OET Bulletin 65 Supplement C: (2001-01)

SCN/75978JD11/008: Base of EUT Facing Phantom EGPRS CH660

Date 17/09/2009

DUT: DELL Mini Cooper CAM H2; Type: LATITUDE E4200; Serial: 00440100304320

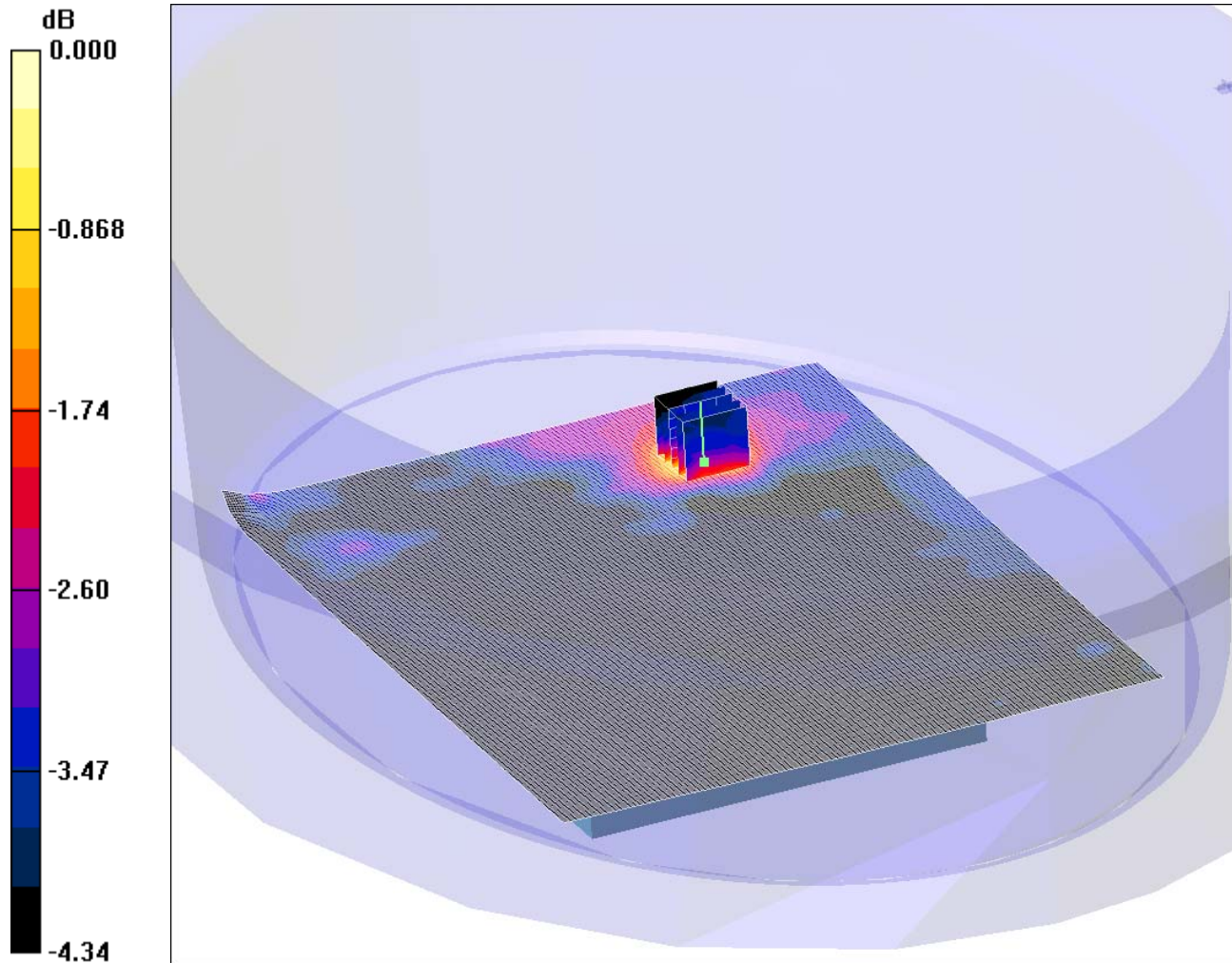

0 dB = 0.050mW/g

Communication System: EGPRS 1900; Frequency: 1879.8 MHz; Duty Cycle: 1:4

Medium: 1900 MHz MSL Medium parameters used (interpolated): $f = 1879.8$ MHz; $\sigma = 1.56$ mho/m; $\epsilon_r = 53.5$; $\rho = 1000$ kg/m³

Phantom section: basin Section

DASY4 Configuration:

- Probe: EX3DV3 - SN3508; ConvF(8.23, 8.23, 8.23); Calibrated: 26/06/2009

- Sensor-Surface: 4mm (Mechanical Surface Detection)

- Electronics: DAE3 Sn450; Calibrated: 30/04/2009

- Phantom: basin; Type: 3mm; Serial: **Not Specified**

- Measurement SW: DASY4, V4.7 Build 55; Postprocessing SW: SEMCAD, V1.8 Build 176

Base of EUT Facing Phantom - Middle /Area Scan (201x261x1): Measurement grid: dx=15mm, dy=15mm

Maximum value of SAR (interpolated) = 0.054 mW/g

Base of EUT Facing Phantom - Middle /Zoom Scan (5x5x7) (5x5x7)/Cube 0: Measurement grid: dx=8mm, dy=8mm, dz=5mm

Reference Value = 2.86 V/m; Power Drift = 0.202 dB

Peak SAR (extrapolated) = 0.063 W/kg

SAR(1 g) = 0.047 mW/g; SAR(10 g) = 0.036 mW/g

Maximum value of SAR (measured) = 0.050 mW/g

Test of: Dell Latitude E4200 Notebook PC

To: OET Bulletin 65 Supplement C: (2001-01)

SCN/75978JD11/009: Base of EUT SKU-900 Facing Phantom EGPRS CH660

Date 30/09/2009

DUT: DELL Mini Cooper CAM H2; Type: LATITUDE E4200; Serial: 00440100304320

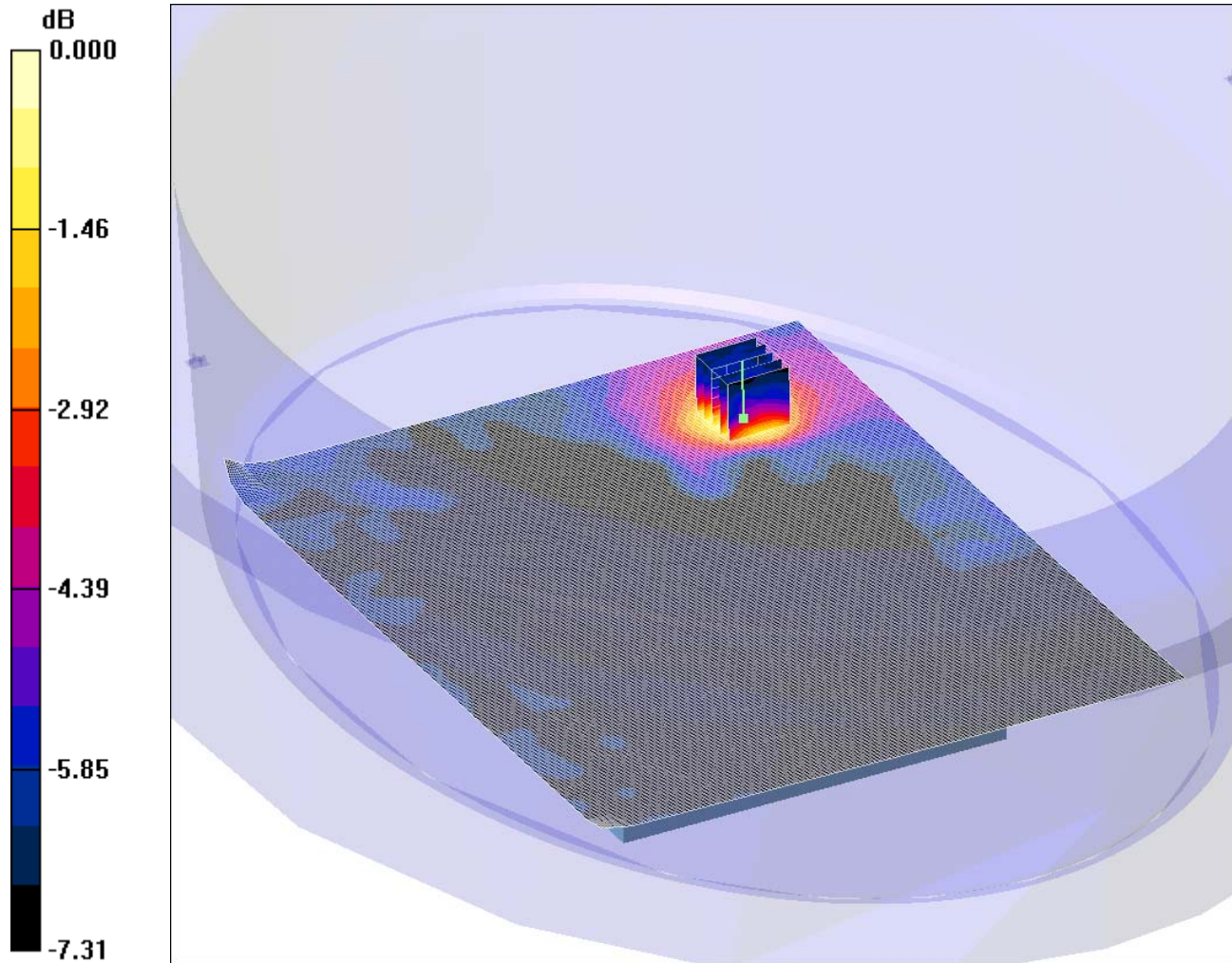

0 dB = 0.045mW/g

Communication System: EGPRS 1900; Frequency: 1879.8 MHz; Duty Cycle: 1:4

Medium: 1900 MHz MSL Medium parameters used (interpolated): $f = 1879.8$ MHz; $\sigma = 1.55$ mho/m; $\epsilon_r = 51.1$; $\rho = 1000$ kg/m³

Phantom section: basin Section

DASY4 Configuration:

- Probe: EX3DV3 - SN3508; ConvF(8.23, 8.23, 8.23); Calibrated: 26/06/2009

- Sensor-Surface: 4mm (Mechanical Surface Detection)

- Electronics: DAE3 Sn450; Calibrated: 30/04/2009

- Phantom: basin; Type: 3mm; Serial: **Not Specified**

- Measurement SW: DASY4, V4.7 Build 55; Postprocessing SW: SEMCAD, V1.8 Build 176

Base of EUT Facing Phantom - Middle/Area Scan (201x261x1): Measurement grid: dx=15mm, dy=15mm

Maximum value of SAR (interpolated) = 0.046 mW/g

Base of EUT Facing Phantom - Middle/Zoom Scan (5x5x7) (5x5x7)/Cube 0: Measurement grid: dx=8mm, dy=8mm, dz=5mm

Reference Value = 2.32 V/m; Power Drift = 0.153 dB

Peak SAR (extrapolated) = 0.063 W/kg

SAR(1 g) = 0.043 mW/g; SAR(10 g) = 0.029 mW/g

Maximum value of SAR (measured) = 0.045 mW/g

Test of: Dell Latitude E4200 Notebook PC

To: OET Bulletin 65 Supplement C: (2001-01)

SCN/75978JD11/010: Base of EUT Facing Phantom FDD II CH9400

Date 28/09/2009

DUT: DELL Mini Cooper CAM H2; Type: LATITUDE E4200; Serial: 00440100304320

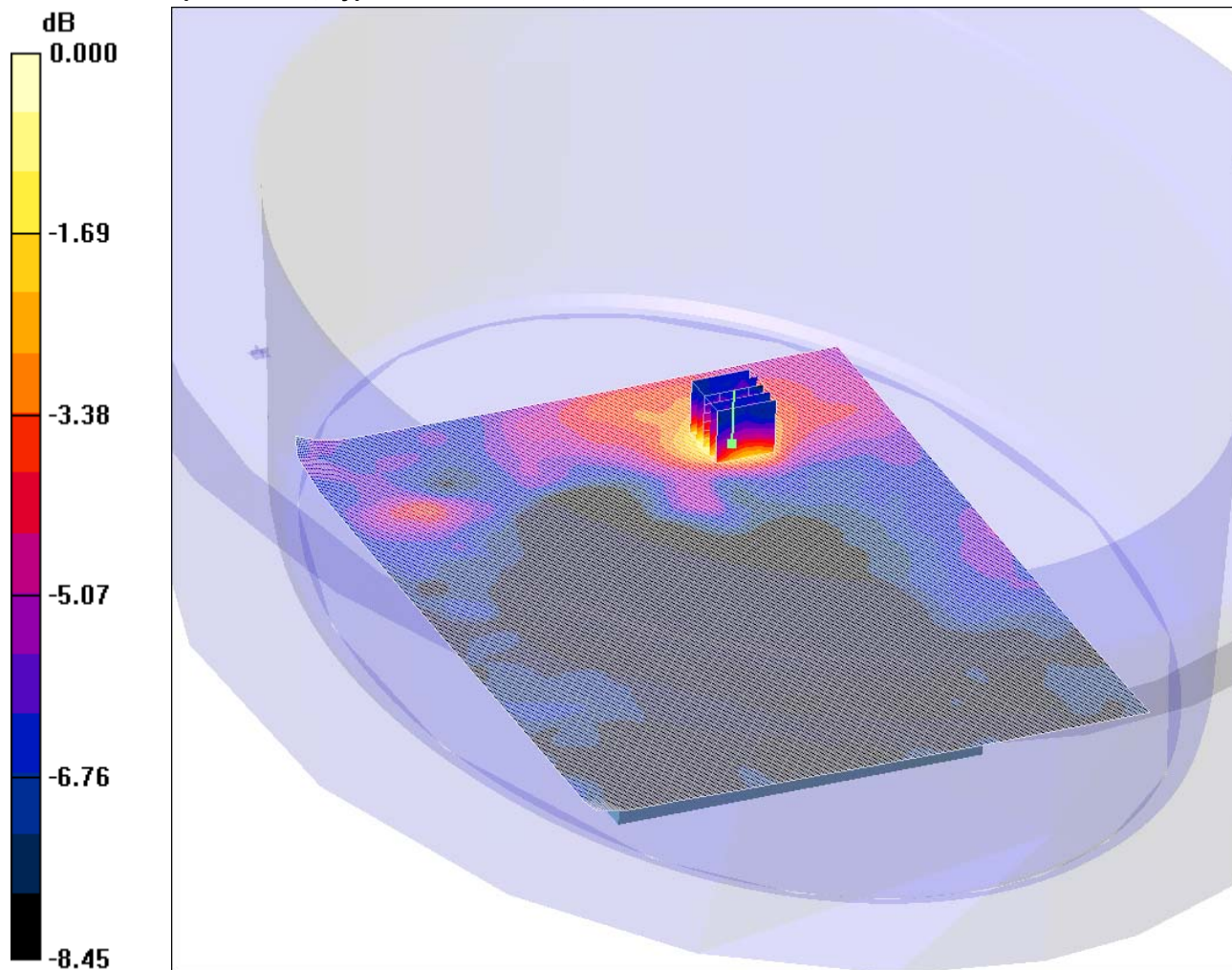

0 dB = 0.043mW/g

Communication System: UMTS-FDD II; Frequency: 1880 MHz; Duty Cycle: 1:1

Medium: 1900 MHz MSL Medium parameters used (interpolated): $f = 1880$ MHz; $\sigma = 1.5$ mho/m; $\epsilon_r = 51$; $\rho = 1000$ kg/m³

Phantom section: basin Section

DASY4 Configuration:

- Probe: EX3DV3 - SN3508; ConvF(8.23, 8.23, 8.23); Calibrated: 26/06/2009

- Sensor-Surface: 4mm (Mechanical Surface Detection)

- Electronics: DAE3 Sn450; Calibrated: 30/04/2009

- Phantom: basin; Type: 3mm; Serial: **Not Specified**

- Measurement SW: DASY4, V4.7 Build 55; Postprocessing SW: SEMCAD, V1.8 Build 176

Base of EUT Facing Phantom - Middle/Area Scan (201x261x1): Measurement grid: dx=15mm, dy=15mm

Maximum value of SAR (interpolated) = 0.043 mW/g

Base of EUT Facing Phantom - Middle/Zoom Scan (5x5x7) (5x5x7)/Cube 0: Measurement grid: dx=8mm, dy=8mm, dz=5mm

Reference Value = 1.81 V/m; Power Drift = 0.596 dB

Peak SAR (extrapolated) = 0.063 W/kg

SAR(1 g) = 0.041 mW/g; SAR(10 g) = 0.028 mW/g

Maximum value of SAR (measured) = 0.043 mW/g

Test of: Dell Latitude E4200 Notebook PC

To: OET Bulletin 65 Supplement C: (2001-01)

SCN/75978JD11/011: Base of EUT Facing Phantom FDD II + HSDPA CH9400

Date 28/09/2009

DUT: DELL Mini Cooper CAM H2; Type: LATITUDE E4200; Serial: 00440100304320

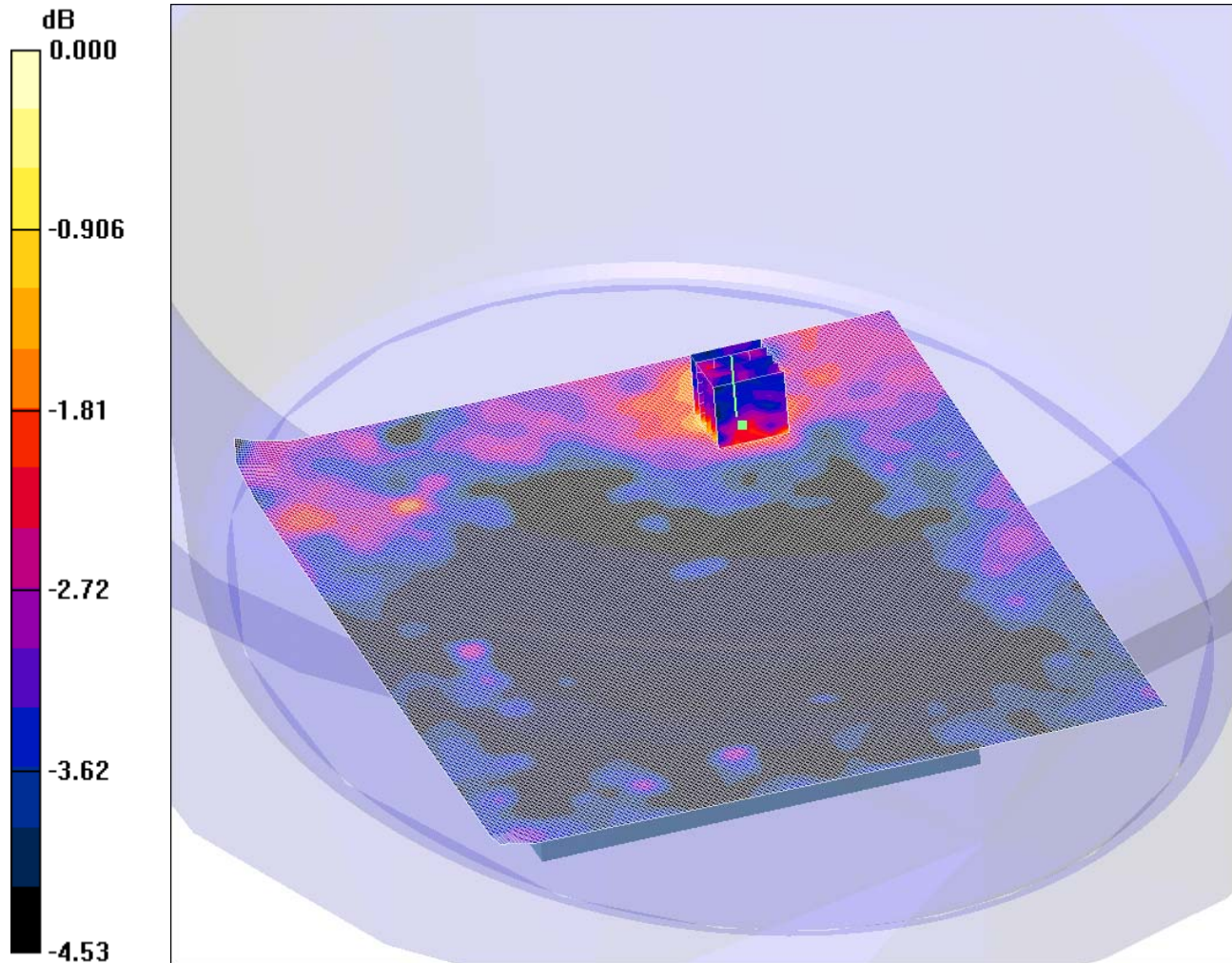

0 dB = 0.015mW/g

Communication System: UMTS-FDD II; Frequency: 1880 MHz; Duty Cycle: 1:1

Medium: 1900 MHz MSL Medium parameters used (interpolated): $f = 1880$ MHz; $\sigma = 1.5$ mho/m; $\epsilon_r = 51$; $\rho = 1000$ kg/m³

Phantom section: basin Section

DASY4 Configuration:

- Probe: EX3DV3 - SN3508; ConvF(8.23, 8.23, 8.23); Calibrated: 26/06/2009

- Sensor-Surface: 4mm (Mechanical Surface Detection)

- Electronics: DAE3 Sn450; Calibrated: 30/04/2009

- Phantom: basin; Type: 3mm; Serial: **Not Specified**

- Measurement SW: DASY4, V4.7 Build 55; Postprocessing SW: SEMCAD, V1.8 Build 176

Base of EUT Facing Phantom - Middle/Area Scan (201x261x1): Measurement grid: dx=15mm, dy=15mm

Maximum value of SAR (interpolated) = 0.015 mW/g

Base of EUT Facing Phantom - Middle/Zoom Scan (5x5x7) (5x5x7)/Cube 0: Measurement grid: dx=8mm, dy=8mm, dz=5mm

Reference Value = 2.22 V/m; Power Drift = -0.482 dB

Peak SAR (extrapolated) = 0.026 W/kg

SAR(1 g) = 0.014 mW/g; SAR(10 g) = 0.011 mW/g

Maximum value of SAR (measured) = 0.015 mW/g

Test of: Dell Latitude E4200 Notebook PC

To: OET Bulletin 65 Supplement C: (2001-01)

SCN/75978JD11/012: Base of EUT Facing Phantom FDD II + HSPA CH9400

Date 25/09/2009

DUT: DELL Mini Cooper CAM H2; Type: LATITUDE E4200; Serial: 00440100304320

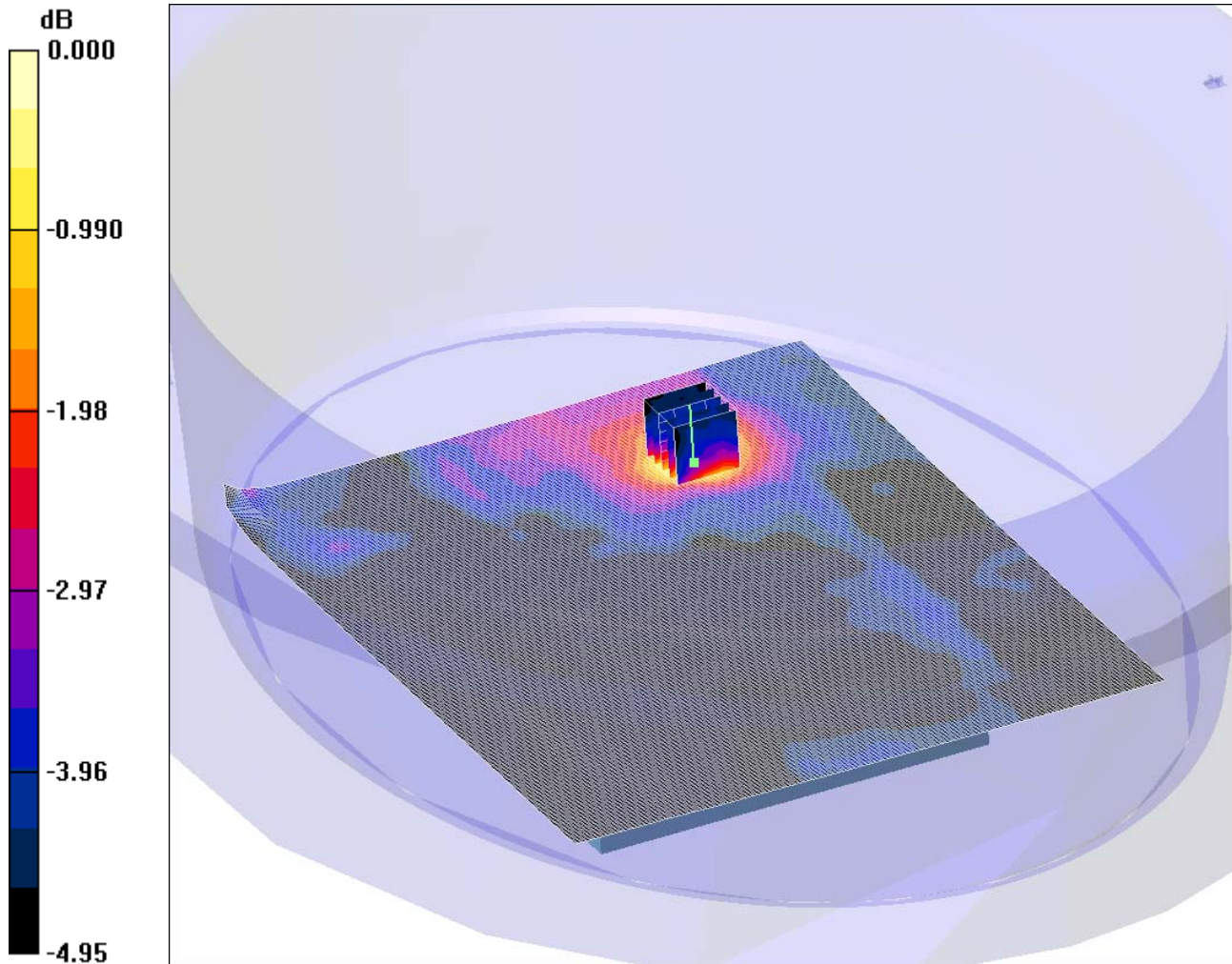

0 dB = 0.033mW/g

Communication System: UMTS-FDD II; Frequency: 1880 MHz; Duty Cycle: 1:1

Medium: 1900 MHz MSL Medium parameters used (interpolated): $f = 1880$ MHz; $\sigma = 1.54$ mho/m; $\epsilon_r = 51.6$; $\rho = 1000$ kg/m³

Phantom section: basin Section

DASY4 Configuration:

- Probe: EX3DV3 - SN3508; ConvF(8.23, 8.23, 8.23); Calibrated: 26/06/2009

- Sensor-Surface: 4mm (Mechanical Surface Detection)

- Electronics: DAE3 Sn450; Calibrated: 30/04/2009

- Phantom: basin; Type: 3mm; Serial: **Not Specified**

- Measurement SW: DASY4, V4.7 Build 55; Postprocessing SW: SEMCAD, V1.8 Build 176

Base of EUT Facing Phantom - Middle/Area Scan (201x261x1): Measurement grid: dx=15mm, dy=15mm

Maximum value of SAR (interpolated) = 0.036 mW/g

Base of EUT Facing Phantom - Middle/Zoom Scan (5x5x7) (5x5x7)/Cube 0: Measurement grid: dx=8mm, dy=8mm, dz=5mm

Reference Value = 2.11 V/m; Power Drift = 0.003 dB

Peak SAR (extrapolated) = 0.047 W/kg

SAR(1 g) = 0.032 mW/g; SAR(10 g) = 0.023 mW/g

Maximum value of SAR (measured) = 0.033 mW/g

Test of: Dell Latitude E4200 Notebook PC

To: OET Bulletin 65 Supplement C: (2001-01)

SCN/75978JD11/013: Base of EUT SKU-900 Facing Phantom FDD II CH9400

Date 01/10/2009

DUT: DELL Mini Cooper CAM H2; Type: LATITUDE E4200; Serial: 00440100304320

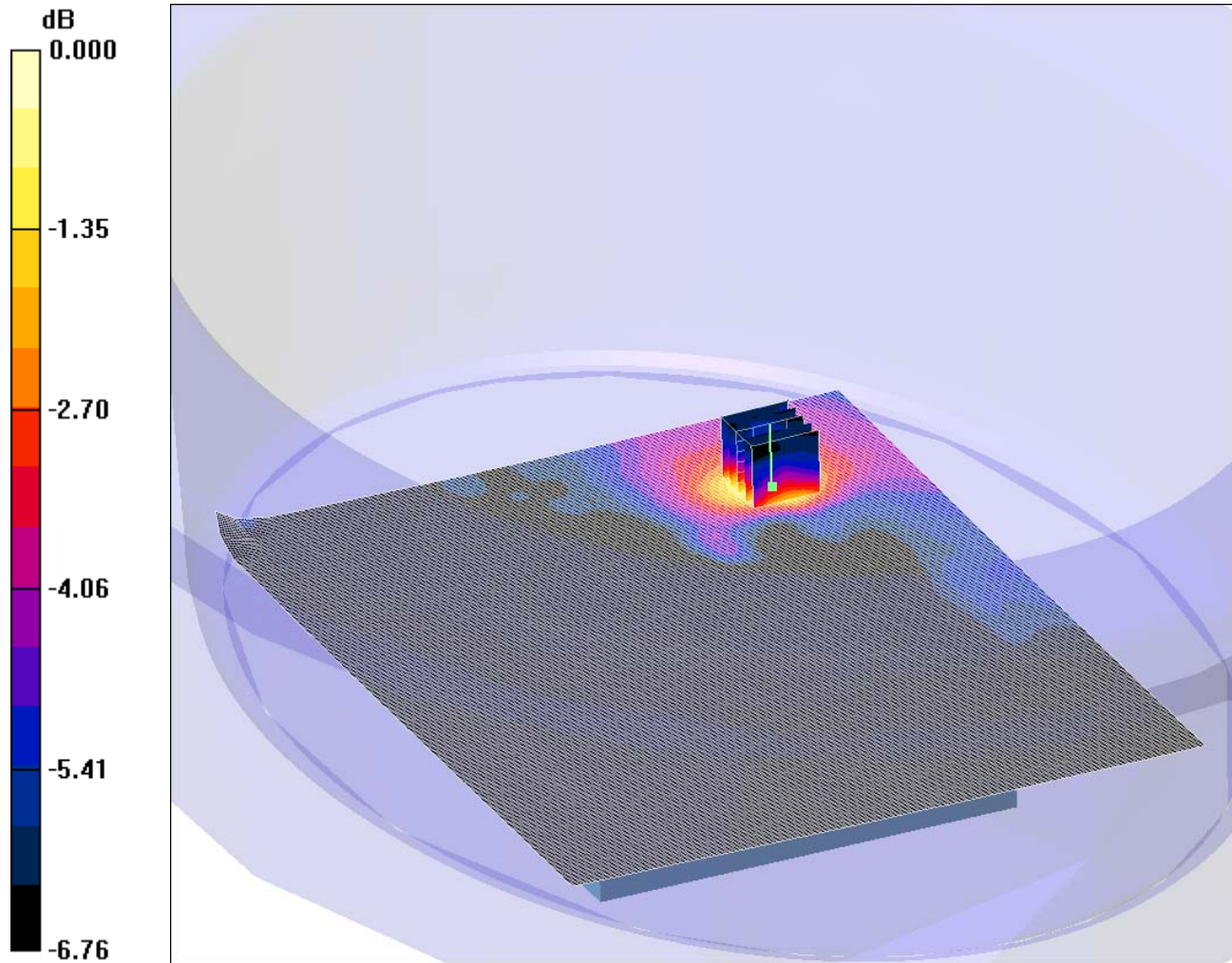

0 dB = 0.052mW/g

Communication System: UMTS-FDD II; Frequency: 1880 MHz; Duty Cycle: 1:1

Medium: 1900 MHz MSL Medium parameters used (interpolated): $f = 1880$ MHz; $\sigma = 1.55$ mho/m; $\epsilon_r = 51.1$; $\rho = 1000$ kg/m³

Phantom section: basin Section

DASY4 Configuration:

- Probe: EX3DV3 - SN3508; ConvF(8.23, 8.23, 8.23); Calibrated: 26/06/2009

- Sensor-Surface: 4mm (Mechanical Surface Detection)

- Electronics: DAE3 Sn450; Calibrated: 30/04/2009

- Phantom: basin; Type: 3mm; Serial: **Not Specified**

- Measurement SW: DASY4, V4.7 Build 55; Postprocessing SW: SEMCAD, V1.8 Build 176

Base of EUT Facing Phantom - Middle/Area Scan (201x261x1): Measurement grid: dx=15mm, dy=15mm

Maximum value of SAR (interpolated) = 0.053 mW/g

Base of EUT Facing Phantom - Middle/Zoom Scan (5x5x7) (5x5x7)/Cube 0: Measurement grid: dx=8mm, dy=8mm, dz=5mm

Reference Value = 1.95 V/m; Power Drift = 0.490 dB

Peak SAR (extrapolated) = 0.075 W/kg

SAR(1 g) = 0.049 mW/g; SAR(10 g) = 0.034 mW/g

Maximum value of SAR (measured) = 0.052 mW/g

Test of: Dell Latitude E4200 Notebook PC

To: OET Bulletin 65 Supplement C: (2001-01)

SCN/75978JD11/014: System Performance Check 1900MHz Body 17 09 09

Date 17/09/2009

DUT: Dipole 1900 MHz; Type: D1900V2; Serial: SN540

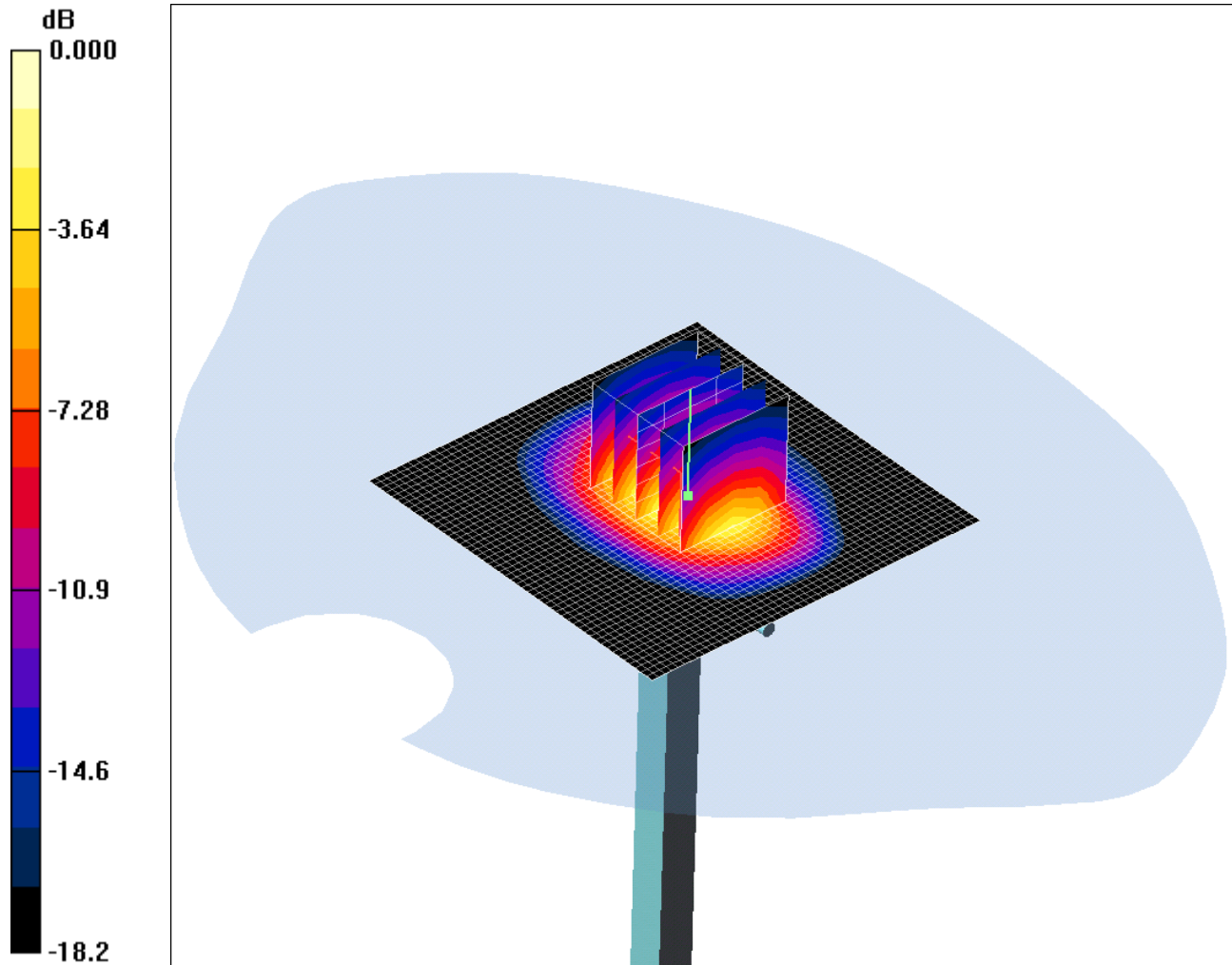

0 dB = 12.0mW/g

Communication System: CW; Frequency: 1900 MHz; Duty Cycle: 1:1

Medium: 1900 MHz MSL Medium parameters used: $f = 1900$ MHz; $\sigma = 1.58$ mho/m; $\epsilon_r = 53.4$; $\rho = 1000$ kg/m³

Phantom section: Flat Section

DASY4 Configuration:

- Probe: EX3DV3 - SN3508; ConvF(8.23, 8.23, 8.23); Calibrated: 26/06/2009

- Sensor-Surface: 4mm (Mechanical Surface Detection)

- Electronics: DAE3 Sn450; Calibrated: 30/04/2009

- Phantom: SAM 12b; Type: SAM 4.0; Serial: TP:1197

- Measurement SW: DASY4, V4.7 Build 55; Postprocessing SW: SEMCAD, V1.8 Build 176

d=10mm, Pin=250mW/Area Scan (51x51x1): Measurement grid: dx=20mm, dy=20mm

Maximum value of SAR (interpolated) = 14.6 mW/g

d=10mm, Pin=250mW/Zoom Scan (5x5x7) (5x5x7)/Cube 0: Measurement grid: dx=8mm, dy=8mm, dz=5mm

Reference Value = 83.6 V/m; Power Drift = 0.048 dB

Peak SAR (extrapolated) = 19.8 W/kg

SAR(1 g) = 10.6 mW/g; SAR(10 g) = 5.38 mW/g

Maximum value of SAR (measured) = 12.0 mW/g

Test of: Dell Latitude E4200 Notebook PC

To: OET Bulletin 65 Supplement C: (2001-01)

SCN/75978JD11/015: System Performance Check 1900MHz Body 18 09 09

Date 18/09/2009

DUT: Dipole 1900 MHz; Type: D1900V2; Serial: SN540

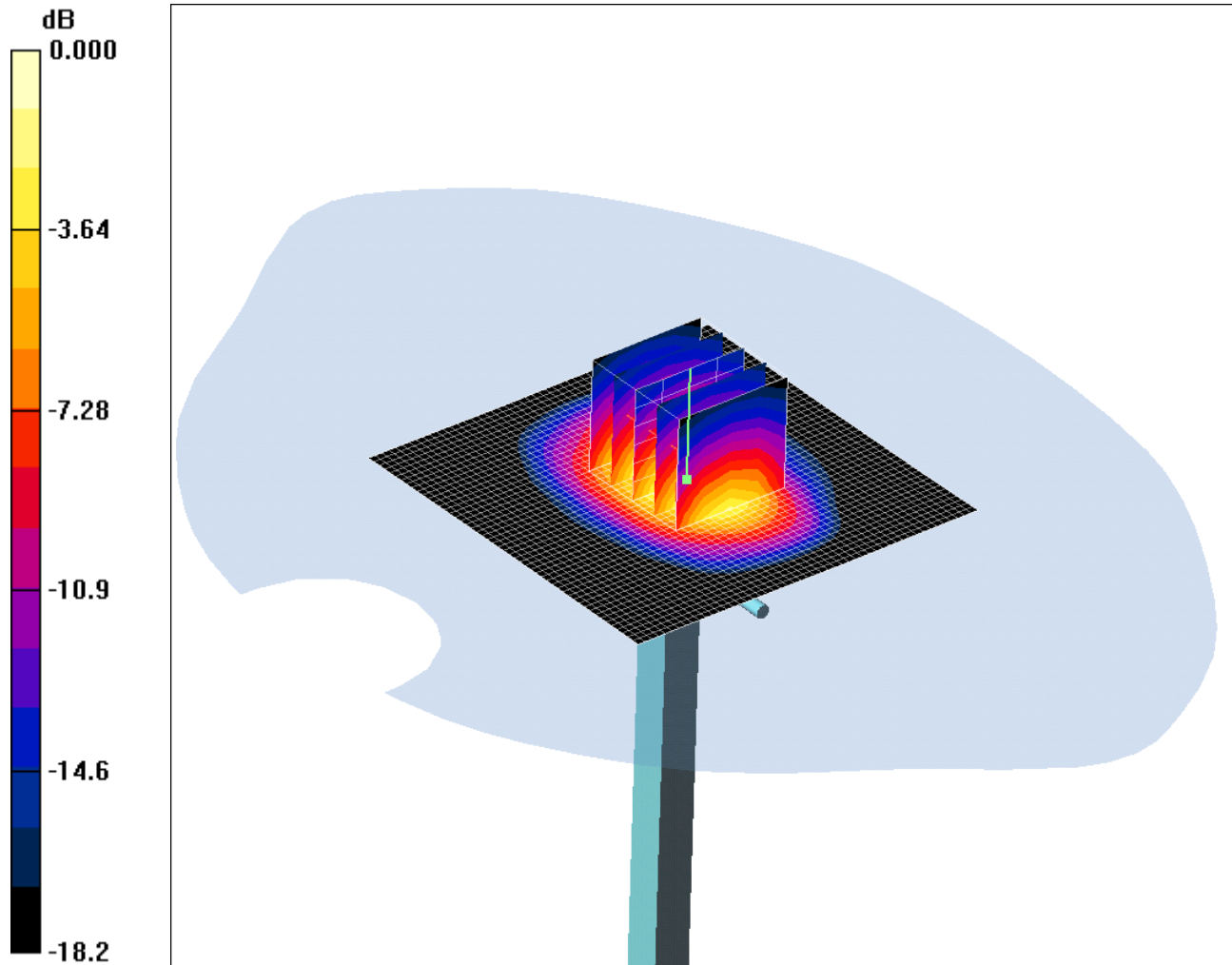

0 dB = 12.0mW/g

Communication System: CW; Frequency: 1900 MHz; Duty Cycle: 1:1

Medium: 1900 MHz MSL Medium parameters used: $f = 1900$ MHz; $\sigma = 1.58$ mho/m; $\epsilon_r = 53.4$; $\rho = 1000$ kg/m³

Phantom section: Flat Section

DASY4 Configuration:

- Probe: EX3DV3 - SN3508; ConvF(8.23, 8.23, 8.23); Calibrated: 26/06/2009

- Sensor-Surface: 4mm (Mechanical Surface Detection)

- Electronics: DAE3 Sn450; Calibrated: 30/04/2009

- Phantom: SAM 12b; Type: SAM 4.0; Serial: TP:1197

- Measurement SW: DASY4, V4.7 Build 55; Postprocessing SW: SEMCAD, V1.8 Build 176

d=10mm, Pin=250mW/Area Scan (51x51x1): Measurement grid: dx=20mm, dy=20mm

Maximum value of SAR (interpolated) = 14.9 mW/g

d=10mm, Pin=250mW/Zoom Scan (5x5x7) (5x5x7)/Cube 0: Measurement grid: dx=8mm, dy=8mm, dz=5mm

Reference Value = 83.5 V/m; Power Drift = 0.004 dB

Peak SAR (extrapolated) = 20.0 W/kg

SAR(1 g) = 10.6 mW/g; SAR(10 g) = 5.41 mW/g

Maximum value of SAR (measured) = 12.0 mW/g

Test of: Dell Latitude E4200 Notebook PC

To: OET Bulletin 65 Supplement C: (2001-01)

SCN/75978JD11/016: System Performance Check 1900MHz Body 25 09 09

Date 25/09/2009

DUT: Dipole 1900 MHz; Type: D1900V2; Serial: SN540

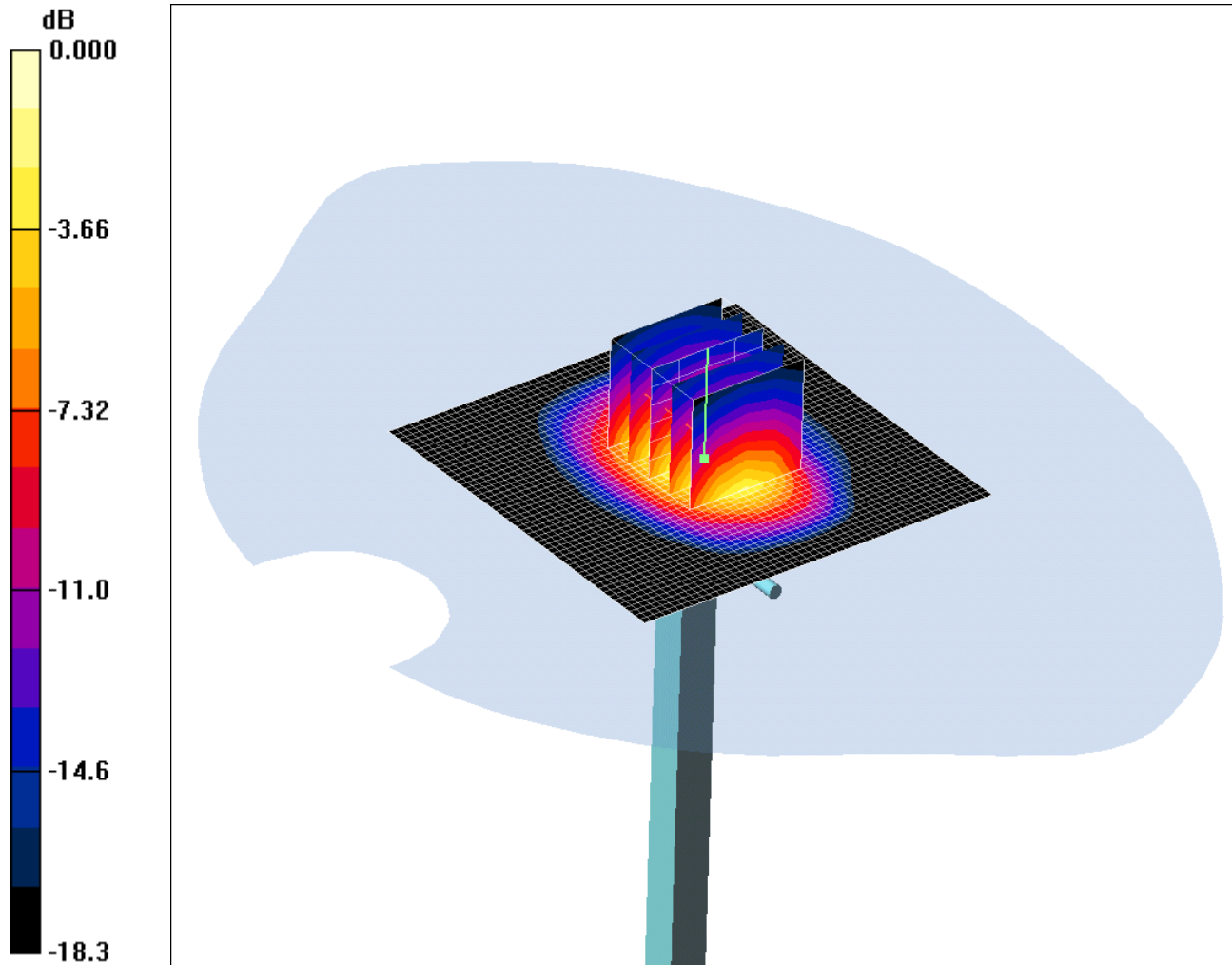

0 dB = 11.8mW/g

Communication System: CW; Frequency: 1900 MHz; Duty Cycle: 1:1

Medium: 1900 MHz MSL Medium parameters used: $f = 1900$ MHz; $\sigma = 1.56$ mho/m; $\epsilon_r = 51.5$; $\rho = 1000$ kg/m³

Phantom section: Flat Section

DASY4 Configuration:

- Probe: EX3DV3 - SN3508; ConvF(8.23, 8.23, 8.23); Calibrated: 26/06/2009

- Sensor-Surface: 4mm (Mechanical Surface Detection)

- Electronics: DAE3 Sn450; Calibrated: 30/04/2009

- Phantom: SAM 12b; Type: SAM 4.0; Serial: TP:1197

- Measurement SW: DASY4, V4.7 Build 55; Postprocessing SW: SEMCAD, V1.8 Build 176

d=10mm, Pin=250mW/Area Scan (51x51x1): Measurement grid: dx=20mm, dy=20mm

Maximum value of SAR (interpolated) = 14.5 mW/g

d=10mm, Pin=250mW/Zoom Scan (5x5x7) (5x5x7)/Cube 0: Measurement grid: dx=8mm, dy=8mm, dz=5mm

Reference Value = 83.6 V/m; Power Drift = 0.051 dB

Peak SAR (extrapolated) = 19.6 W/kg

SAR(1 g) = 10.4 mW/g; SAR(10 g) = 5.29 mW/g

Maximum value of SAR (measured) = 11.8 mW/g

Test of: Dell Latitude E4200 Notebook PC

To: OET Bulletin 65 Supplement C: (2001-01)

SCN/75978JD11/017: System Performance Check 1900MHz Body 28 09 09

Date 28/09/2009

DUT: Dipole 1900 MHz; Type: D1900V2; Serial: SN540

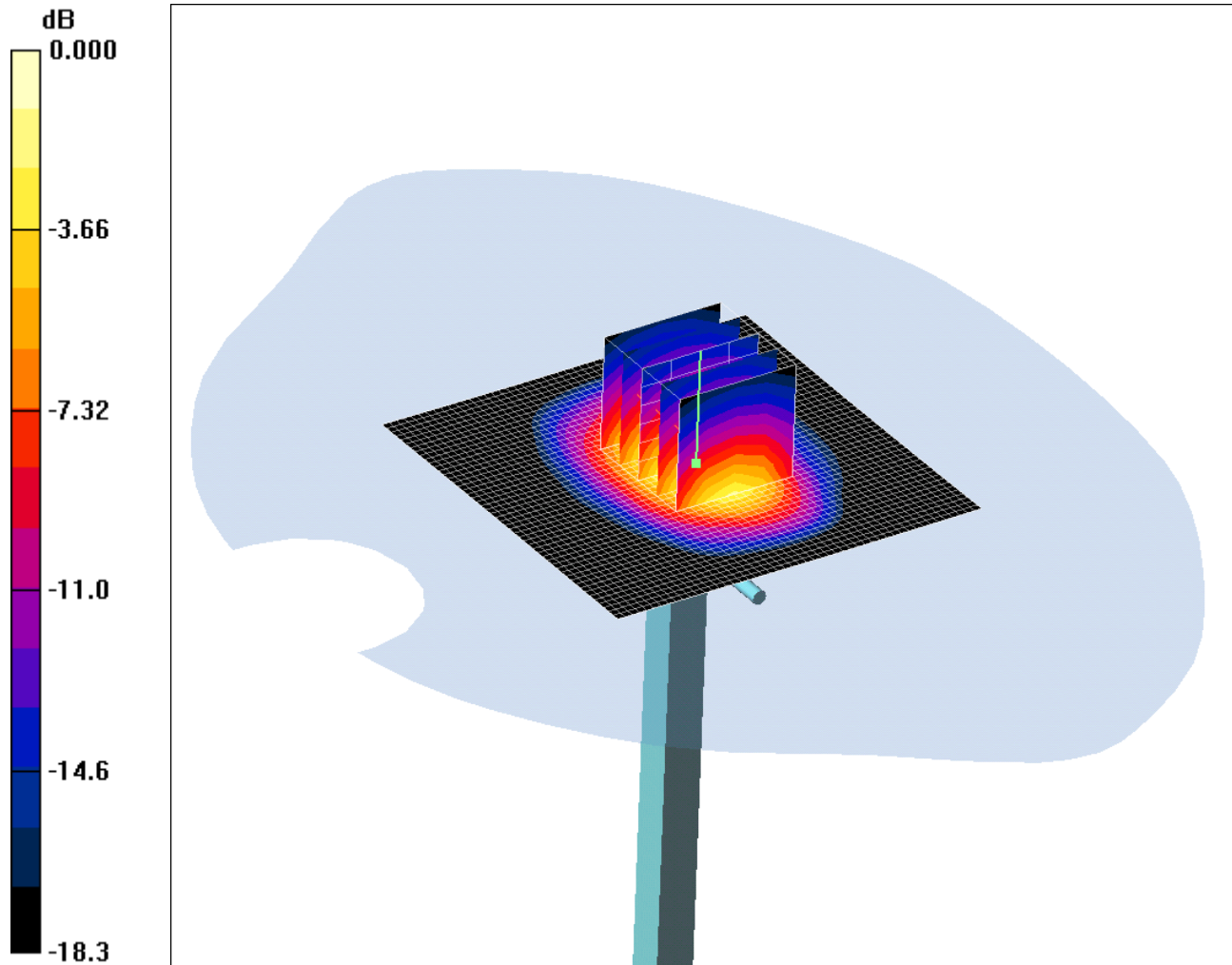

0 dB = 11.5mW/g

Communication System: CW; Frequency: 1900 MHz; Duty Cycle: 1:1

Medium: 1900 MHz MSL Medium parameters used: $f = 1900$ MHz; $\sigma = 1.53$ mho/m; $\epsilon_r = 50.8$; $\rho = 1000$ kg/m³

Phantom section: Flat Section

DASY4 Configuration:

- Probe: EX3DV3 - SN3508; ConvF(8.23, 8.23, 8.23); Calibrated: 26/06/2009

- Sensor-Surface: 4mm (Mechanical Surface Detection)

- Electronics: DAE3 Sn450; Calibrated: 30/04/2009

- Phantom: SAM 12b; Type: SAM 4.0; Serial: TP:1197

- Measurement SW: DASY4, V4.7 Build 55; Postprocessing SW: SEMCAD, V1.8 Build 176

d=10mm, Pin=250mW/Area Scan (51x51x1): Measurement grid: dx=20mm, dy=20mm

Maximum value of SAR (interpolated) = 14.0 mW/g

d=10mm, Pin=250mW/Zoom Scan (5x5x7) (5x5x7)/Cube 0: Measurement grid: dx=8mm, dy=8mm, dz=5mm

Reference Value = 83.8 V/m; Power Drift = 0.003 dB

Peak SAR (extrapolated) = 19.3 W/kg

SAR(1 g) = 10.2 mW/g; SAR(10 g) = 5.2 mW/g

Maximum value of SAR (measured) = 11.5 mW/g

Test of: Dell Latitude E4200 Notebook PC

To: OET Bulletin 65 Supplement C: (2001-01)

SCN/75978JD11/018: System Performance Check 900MHz Body 28 09 09

Date 28/09/2009

DUT: Dipole 900 MHz; Type: D900V2; Serial: SN185

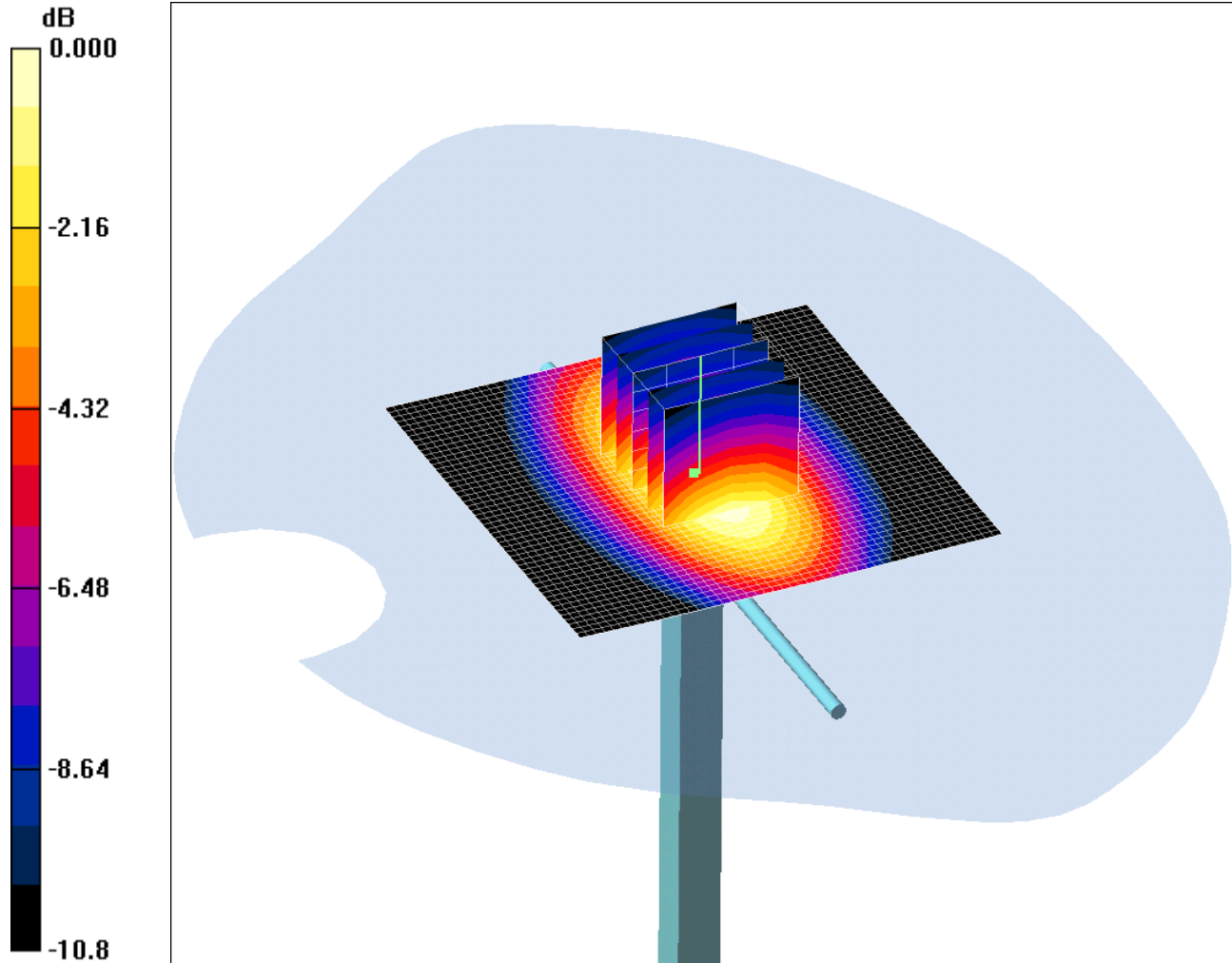

0 dB = 3.08mW/g

Communication System: CW; Frequency: 900 MHz; Duty Cycle: 1:1

Medium: 900 MHz MSL Medium parameters used: $f = 900$ MHz; $\sigma = 1.06$ mho/m; $\epsilon_r = 53.2$; $\rho = 1000$ kg/m³

Phantom section: Flat Section

DASY4 Configuration:

- Probe: EX3DV3 - SN3508; ConvF(9.99, 9.99, 9.99); Calibrated: 26/06/2009

- Sensor-Surface: 4mm (Mechanical Surface Detection)

- Electronics: DAE3 Sn450; Calibrated: 30/04/2009

- Phantom: SAM 12a; Type: SAM 4.0; Serial: TP:1193

- Measurement SW: DASY4, V4.7 Build 55; Postprocessing SW: SEMCAD, V1.8 Build 176

d=15mm, Pin=250mW/Area Scan (51x51x1): Measurement grid: dx=20mm, dy=20mm

Maximum value of SAR (interpolated) = 3.16 mW/g

d=15mm, Pin=250mW/Zoom Scan (5x5x7) (5x5x7)/Cube 0: Measurement grid: dx=8mm, dy=8mm, dz=5mm

Reference Value = 53.9 V/m; Power Drift = 0.010 dB

Peak SAR (extrapolated) = 4.28 W/kg

SAR(1 g) = 2.85 mW/g; SAR(10 g) = 1.85 mW/g

Maximum value of SAR (measured) = 3.08 mW/g

Test of: Dell Latitude E4200 Notebook PC

To: OET Bulletin 65 Supplement C: (2001-01)

SCN/75978JD11/019: System Performance Check 900MHz Body 29 09 09

Date 29/09/2009

DUT: Dipole 900 MHz; Type: D900V2; Serial: SN185

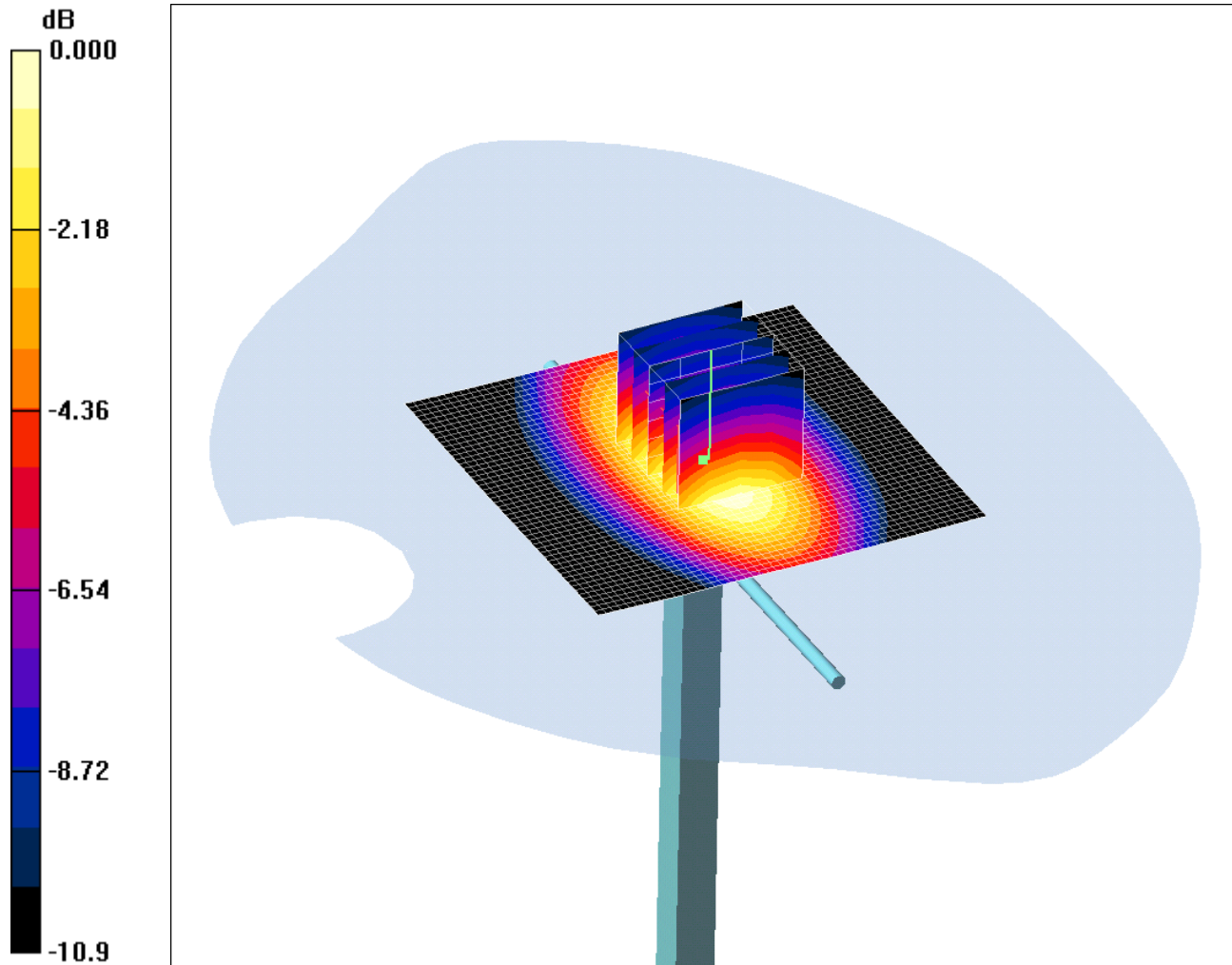

0 dB = 3.05mW/g

Communication System: CW; Frequency: 900 MHz; Duty Cycle: 1:1

Medium: 900 MHz MSL Medium parameters used: $f = 900$ MHz; $\sigma = 1.06$ mho/m; $\epsilon_r = 53.2$; $\rho = 1000$ kg/m³

Phantom section: Flat Section

DASY4 Configuration:

- Probe: EX3DV3 - SN3508; ConvF(9.99, 9.99, 9.99); Calibrated: 26/06/2009

- Sensor-Surface: 4mm (Mechanical Surface Detection)

- Electronics: DAE3 Sn450; Calibrated: 30/04/2009

- Phantom: SAM 12a; Type: SAM 4.0; Serial: TP:1193

- Measurement SW: DASY4, V4.7 Build 55; Postprocessing SW: SEMCAD, V1.8 Build 176

d=15mm, Pin=250mW/Area Scan (51x51x1): Measurement grid: dx=20mm, dy=20mm

Maximum value of SAR (interpolated) = 3.18 mW/g

d=15mm, Pin=250mW/Zoom Scan (5x5x7) (5x5x7)/Cube 0: Measurement grid: dx=8mm, dy=8mm, dz=5mm

Reference Value = 54.1 V/m; Power Drift = 0.001 dB

Peak SAR (extrapolated) = 4.27 W/kg

SAR(1 g) = 2.84 mW/g; SAR(10 g) = 1.85 mW/g

Maximum value of SAR (measured) = 3.05 mW/g

Test of: Dell Latitude E4200 Notebook PC

To: OET Bulletin 65 Supplement C: (2001-01)

SCN/75978JD11/020: System Performance Check 900MHz Body 30 09 09

Date 30/09/2009

DUT: Dipole 900 MHz; Type: D900V2; Serial: SN185

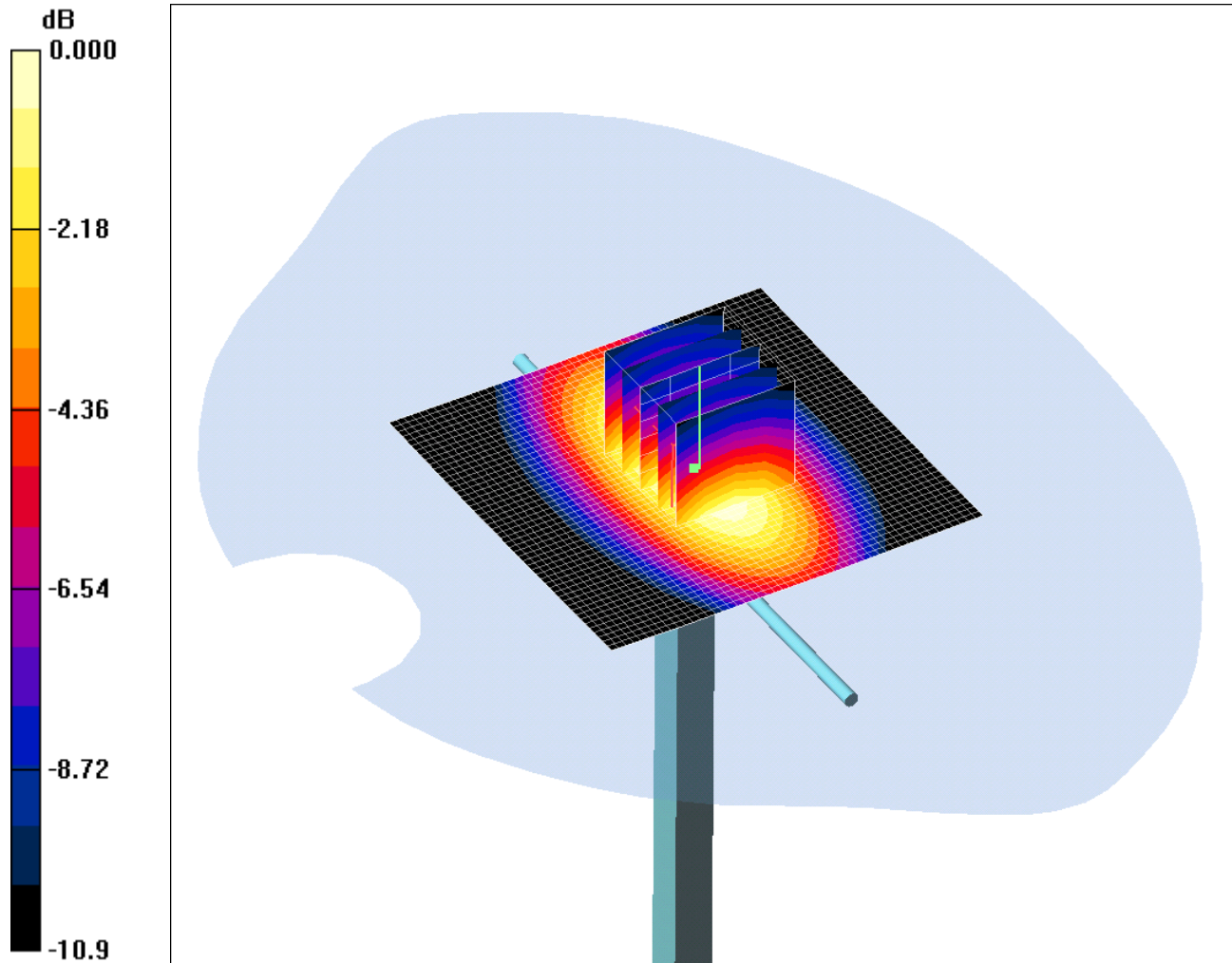

0 dB = 2.99mW/g

Communication System: CW; Frequency: 900 MHz; Duty Cycle: 1:1

Medium: 900 MHz MSL Medium parameters used: $f = 900$ MHz; $\sigma = 1.03$ mho/m; $\epsilon_r = 53.5$; $\rho = 1000$ kg/m³

Phantom section: Flat Section

DASY4 Configuration:

- Probe: EX3DV3 - SN3508; ConvF(9.99, 9.99, 9.99); Calibrated: 26/06/2009

- Sensor-Surface: 4mm (Mechanical Surface Detection)

- Electronics: DAE3 Sn450; Calibrated: 30/04/2009

- Phantom: SAM 12a; Type: SAM 4.0; Serial: TP:1193

- Measurement SW: DASY4, V4.7 Build 55; Postprocessing SW: SEMCAD, V1.8 Build 176

d=15mm, Pin=250mW/Area Scan (51x51x1): Measurement grid: dx=20mm, dy=20mm

Maximum value of SAR (interpolated) = 3.11 mW/g

d=15mm, Pin=250mW/Zoom Scan (5x5x7) (5x5x7)/Cube 0: Measurement grid: dx=8mm, dy=8mm, dz=5mm

Reference Value = 54.0 V/m; Power Drift = 0.018 dB

Peak SAR (extrapolated) = 4.19 W/kg

SAR(1 g) = 2.79 mW/g; SAR(10 g) = 1.81 mW/g

Maximum value of SAR (measured) = 2.99 mW/g

Test of: Dell Latitude E4200 Notebook PC

To: OET Bulletin 65 Supplement C: (2001-01)

SCN/75978JD11/021: System Performance Check 1900MHz Body 30 09 09

Date 30/09/2009

DUT: Dipole 1900 MHz; Type: D1900V2; Serial: SN540

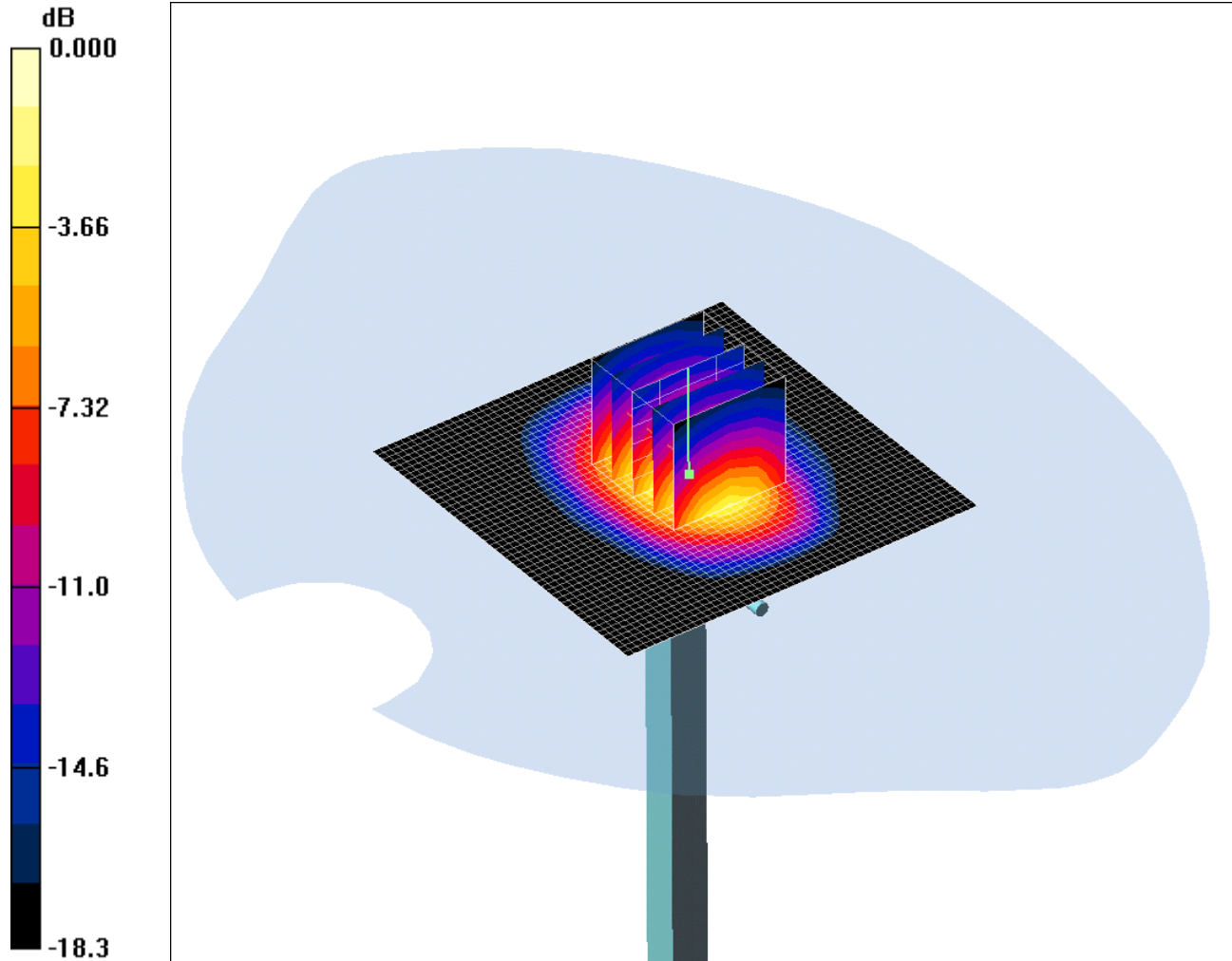

0 dB = 11.9mW/g

Communication System: CW; Frequency: 1900 MHz; Duty Cycle: 1:1

Medium: 1900 MHz MSL Medium parameters used: $f = 1900$ MHz; $\sigma = 1.58$ mho/m; $\epsilon_r = 51$; $\rho = 1000$ kg/m³

Phantom section: Flat Section

DASY4 Configuration:

- Probe: EX3DV3 - SN3508; ConvF(8.23, 8.23, 8.23); Calibrated: 26/06/2009

- Sensor-Surface: 4mm (Mechanical Surface Detection)

- Electronics: DAE3 Sn450; Calibrated: 30/04/2009

- Phantom: SAM 12b; Type: SAM 4.0; Serial: TP:1197

- Measurement SW: DASY4, V4.7 Build 55; Postprocessing SW: SEMCAD, V1.8 Build 176

d=10mm, Pin=250mW/Area Scan (51x51x1): Measurement grid: dx=20mm, dy=20mm

Maximum value of SAR (interpolated) = 14.7 mW/g

d=10mm, Pin=250mW/Zoom Scan (5x5x7) (5x5x7)/Cube 0: Measurement grid: dx=8mm, dy=8mm, dz=5mm

Reference Value = 83.9 V/m; Power Drift = -0.036 dB

Peak SAR (extrapolated) = 19.9 W/kg

SAR(1 g) = 10.5 mW/g; SAR(10 g) = 5.35 mW/g

Maximum value of SAR (measured) = 11.9 mW/g

Test of: Dell Latitude E4200 Notebook PC

To: OET Bulletin 65 Supplement C: (2001-01)

SCN/75978JD11/022: System Performance Check 1900MHz Body 01 10 09

Date 01/10/2009

DUT: Dipole 1900 MHz; Type: D1900V2; Serial: SN540

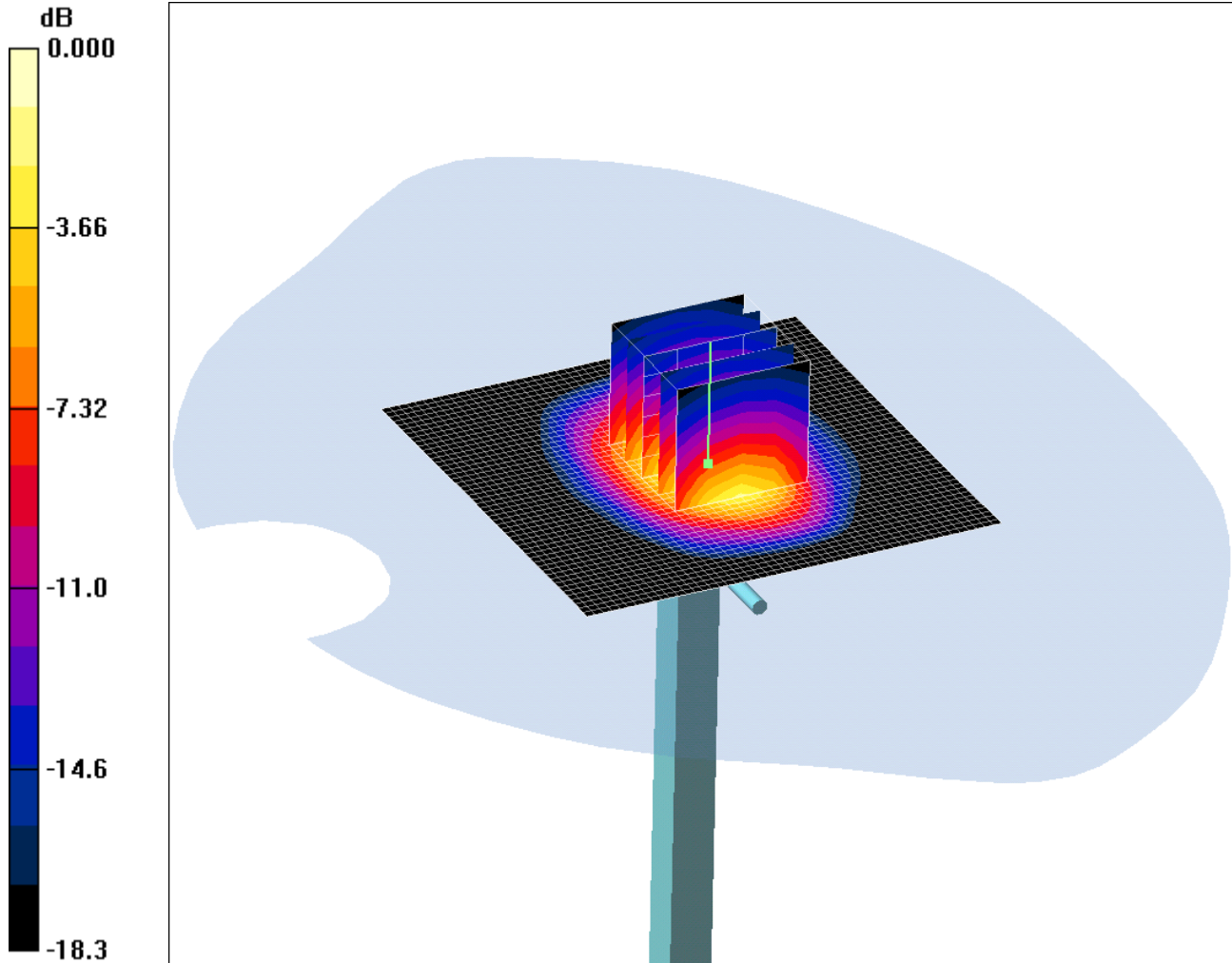

0 dB = 11.9mW/g

Communication System: CW; Frequency: 1900 MHz; Duty Cycle: 1:1

Medium: 1900 MHz MSL Medium parameters used: $f = 1900$ MHz; $\sigma = 1.58$ mho/m; $\epsilon_r = 51$; $\rho = 1000$ kg/m³

Phantom section: Flat Section

DASY4 Configuration:

- Probe: EX3DV3 - SN3508; ConvF(8.23, 8.23, 8.23); Calibrated: 26/06/2009

- Sensor-Surface: 4mm (Mechanical Surface Detection)

- Electronics: DAE3 Sn450; Calibrated: 30/04/2009

- Phantom: SAM 12b; Type: SAM 4.0; Serial: TP:1197

- Measurement SW: DASY4, V4.7 Build 55; Postprocessing SW: SEMCAD, V1.8 Build 176

d=10mm, Pin=250mW/Area Scan (51x51x1): Measurement grid: dx=20mm, dy=20mm

Maximum value of SAR (interpolated) = 14.5 mW/g

d=10mm, Pin=250mW/Zoom Scan (5x5x7) (5x5x7)/Cube 0: Measurement grid: dx=8mm, dy=8mm, dz=5mm

Reference Value = 83.8 V/m; Power Drift = -0.016 dB

Peak SAR (extrapolated) = 19.9 W/kg

SAR(1 g) = 10.5 mW/g; SAR(10 g) = 5.35 mW/g

Maximum value of SAR (measured) = 11.9 mW/g

Test of: Dell Latitude E4200 Notebook PC

To: OET Bulletin 65 Supplement C: (2001-01)

Appendix 4. Photographs

This appendix contains the following photographs:

Photo Reference Number	Title
PHT/75978JD11/001	Test configuration for the measurement of Specific Absorption Rate (SAR)
PHT/75978JD11/002	Front View of EUT
PHT/75978JD11/003	Rear View of EUT
PHT/75978JD11/004	EUT With Display Open at 90 Degrees to Keyboard
PHT/75978JD11/005	Internal View of EUT
PHT/75978JD11/006	Battery View
PHT/75978JD11/007	Base of EUT with Display at 90 Degrees to Keyboard Facing Phantom
PHT/75978JD11/008	1900 MHz Body Fluid Level
PHT/75978JD11/009	900 MHz Body Fluid Level

Test of: Dell Latitude E4200 Notebook PC

To: OET Bulletin 65 Supplement C: (2001-01)

PHT/75978JD11/001: Test configuration for the measurement of Specific Absorption Rate (SAR)



Test of: Dell Latitude E4200 Notebook PC

To: OET Bulletin 65 Supplement C: (2001-01)

PHT/75978JD11/002: Front View of EUT



Test of: Dell Latitude E4200 Notebook PC

To: OET Bulletin 65 Supplement C: (2001-01)

PHT/75978JD11/003: Rear View of EUT



Test of: Dell Latitude E4200 Notebook PC

To: OET Bulletin 65 Supplement C: (2001-01)

PHT/75978JD11/004: EUT With Display Open at 90 Degrees to Keyboard



Test of: Dell Latitude E4200 Notebook PC

To: OET Bulletin 65 Supplement C: (2001-01)

PHT/75978JD11/005: Internal View of EUT



Test of: Dell Latitude E4200 Notebook PC

To: OET Bulletin 65 Supplement C: (2001-01)

PHT/75978JD11/006: Battery View



Test of: Dell Latitude E4200 Notebook PC

To: OET Bulletin 65 Supplement C: (2001-01)

PHT/75978JD11/007: Base of EUT with Display at 90 Degrees to Keyboard Facing Phantom



Test of: Dell Latitude E4200 Notebook PC

To: OET Bulletin 65 Supplement C: (2001-01)

PHT/75978JD11/008: 1900 MHz Body Fluid Level



Test of: Dell Latitude E4200 Notebook PC

To: OET Bulletin 65 Supplement C: (2001-01)

PHT/75978JD11/009: 900 MHz Body Fluid Level

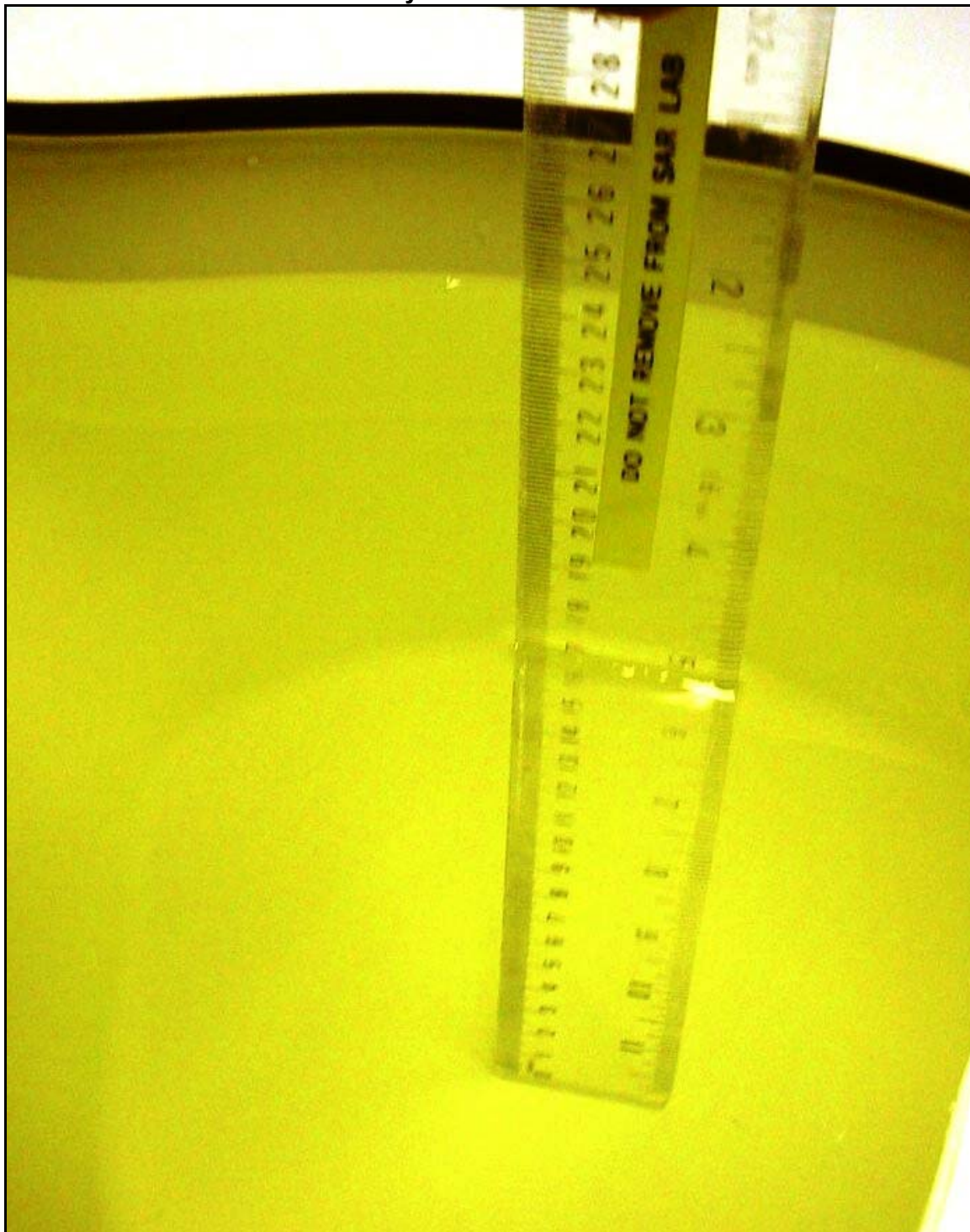

Test of: Dell Latitude E4200 Notebook PC

To: OET Bulletin 65 Supplement C: (2001-01)

Appendix 5. Validation of System

Prior to the assessment, the system was verified in the flat region of the phantom.

900 MHz and 1900 MHz dipoles were used. A forward power of 250 mW was applied to the dipole and the system was verified to a tolerance of $\pm 5\%$ for the 900 MHz and 1900 MHz dipole. The applicable verification (normalised to 1 Watt).

Date: 28/09/2009**Validation Dipole and Serial Number: D900V2 SN:124**

Simulant	Frequency (MHz)	Room Temperature	Liquid Temperature	Parameters	Target Value	Measured Value	Deviation (%)	Limit (%)
Body	900	25.0 °C	24.2 °C	ϵ_r	55.00	53.17	-3.33	5.00
				σ	1.05	1.06	0.52	5.00
				1g SAR	11.00	11.40	3.64	5.00
				10g SAR	7.16	7.40	3.35	5.00

Date: 29/09/2009**Validation Dipole and Serial Number: D900V2 SN:124**

Simulant	Frequency (MHz)	Room Temperature	Liquid Temperature	Parameters	Target Value	Measured Value	Deviation (%)	Limit (%)
Body	900	25.0 °C	24.2 °C	ϵ_r	55.00	53.17	-3.33	5.00
				σ	1.05	1.06	0.52	5.00
				1g SAR	11.00	11.36	3.27	5.00
				10g SAR	7.16	7.40	3.35	5.00

Date: 30/09/2009**Validation Dipole and Serial Number: D900V2 SN:124**

Simulant	Frequency (MHz)	Room Temperature	Liquid Temperature	Parameters	Target Value	Measured Value	Deviation (%)	Limit (%)
Body	900	24.0 °C	21.9 °C	ϵ_r	55.00	53.53	-2.68	5.00
				σ	1.05	1.03	-2.13	5.00
				1g SAR	11.00	11.16	1.45	5.00
				10g SAR	7.16	7.24	1.12	5.00

Test of: Dell Latitude E4200 Notebook PC

To: OET Bulletin 65 Supplement C: (2001-01)

Date: 17/09/2009**Validation Dipole and Serial Number: D1900V2:SN:540**

Simulant	Frequency (MHz)	Room Temperature	Liquid Temperature	Parameters	Target Value	Measured Value	Deviation (%)	Limit (%)
Body	1900	24.0 °C	24.0 °C	ϵ_r	53.30	53.44	0.27	5.00
				σ	1.52	1.58	3.75	5.00
				1g SAR	40.90	42.40	3.67	5.00
				10g SAR	21.50	21.52	0.09	5.00

Date: 25/09/2009**Validation Dipole and Serial Number: D1900V2:SN:540**

Simulant	Frequency (MHz)	Room Temperature	Liquid Temperature	Parameters	Target Value	Measured Value	Deviation (%)	Limit (%)
Body	1900	25.0 °C	23.4 °C	ϵ_r	53.30	51.55	-3.28	5.00
				σ	1.52	1.56	2.53	5.00
				1g SAR	40.90	41.60	1.71	5.00
				10g SAR	21.50	21.16	-1.58	5.00

Date:28/09/2009**Validation Dipole and Serial Number:D1900V2:SN:540**

Simulant	Frequency (MHz)	Room Temperature	Liquid Temperature	Parameters	Target Value	Measured Value	Deviation (%)	Limit (%)
Body	1900	25.0 °C	23.2 °C	ϵ_r	53.30	50.82	-4.65	5.00
				σ	1.52	1.53	0.46	5.00
				1g SAR	40.90	40.80	-0.24	5.00
				10g SAR	21.50	20.80	-3.26	5.00

Test of: Dell Latitude E4200 Notebook PC

To: OET Bulletin 65 Supplement C: (2001-01)

Date: 30/09/2009**Validation Dipole and Serial Number: D1900V2:SN:540**

Simulant	Frequency (MHz)	Room Temperature	Liquid Temperature	Parameters	Target Value	Measured Value	Deviation (%)	Limit (%)
Body	1900	24.0 °C	22.8 °C	ϵ_r	53.30	50.98	-4.36	5.00
				σ	1.52	1.58	3.71	5.00
				1g SAR	40.90	42.00	2.69	5.00
				10g SAR	21.50	21.40	-0.47	5.00

Date: 01/10/2009**Validation Dipole and Serial Number: D1900V2:SN:540**

Simulant	Frequency (MHz)	Room Temperature	Liquid Temperature	Parameters	Target Value	Measured Value	Deviation (%)	Limit (%)
Body	1900	24.0 °C	22.8 °C	ϵ_r	53.30	50.98	-4.36	5.00
				σ	1.52	1.58	3.71	5.00
				1g SAR	40.90	42.00	2.69	5.00
				10g SAR	21.50	21.40	-0.47	5.00

Test of: Dell Latitude E4200 Notebook PC

To: OET Bulletin 65 Supplement C: (2001-01)

Statement for 900MHz Dipole Validation and Probe

The test frequencies are properly matched as this is a cellular band. The probe calibration for permittivity and conductivity is within +/-5%, were the probe calibrated centre frequency at 900MHz has permittivity and conductivity of 55.0 and 1.05 respectively. At the probe extreme frequencies the following are true: at 800 MHz the permittivity and conductivity are 52.3 and 0.92 respectively. At 1000 MHz the permittivity and conductivity are 57.8 and 1.1 respectively. The probe was calibrated at these parameters in order to cover the frequency range 800 MHz to 1000 MHz.

The target permittivity and conductivity at 835 MHz is 55.2 and 0.97 respectively which is within the calibrated range of the probe parameter.

The following parameters are declared in the probe calibration certificate on page 8:

f [MHz]	Validity [MHz] ^c	TSL	Permittivity	Conductivity	Alpha	Depth	ConvF	Uncertainty
450	± 50 / ± 100	Head	43.5 ± 5%	0.87 ± 5%	0.23	1.00	10.49	± 13.3% (k=2)
900	± 50 / ± 100	Head	41.5 ± 5%	0.97 ± 5%	0.48	0.72	9.76	± 11.0% (k=2)
1750	± 50 / ± 100	Head	40.1 ± 5%	1.37 ± 5%	0.57	0.63	8.82	± 11.0% (k=2)
1900	± 50 / ± 100	Head	40.0 ± 5%	1.40 ± 5%	0.53	0.65	8.58	± 11.0% (k=2)
2150	± 50 / ± 101	Head	39.7 ± 5%	1.53 ± 5%	0.36	0.69	8.33	± 11.0% (k=2)
2450	± 50 / ± 100	Head	39.2 ± 5%	1.80 ± 5%	0.36	0.75	7.77	± 11.0% (k=2)
450	± 50 / ± 100	Body	56.7 ± 5%	0.94 ± 5%	0.30	0.51	11.32	± 13.3% (k=2)
900	± 50 / ± 100	Body	55.0 ± 5%	1.05 ± 5%	0.45	0.75	9.99	± 11.0% (k=2)
1750	± 50 / ± 100	Body	53.4 ± 5%	1.49 ± 5%	0.55	0.63	8.59	± 11.0% (k=2)
1900	± 50 / ± 100	Body	53.3 ± 5%	1.52 ± 5%	0.48	0.68	8.23	± 11.0% (k=2)
2150	± 50 / ± 100	Body	53.0 ± 5%	1.75 ± 5%	0.30	0.92	8.27	± 11.0% (k=2)
2450	± 50 / ± 100	Body	52.7 ± 5%	1.95 ± 5%	0.25	1.02	8.06	± 11.0% (k=2)

^c The validity of ± 100 MHz only applies for DASy v4.4 and higher (see Page 2). The uncertainty is the RSS of the ConvF uncertainty at calibration frequency and the uncertainty for the indicated frequency band.

Test of: Dell Latitude E4200 Notebook PC

To: OET Bulletin 65 Supplement C: (2001-01)

The system manufacturer has carried out addition steps as detailed on page 4 of KDB450824. This is detailed in the calibration certificates. The measured SAR values in the report are all below 10% of the SAR limit.

The measured fluid dielectric parameters for 835 MHz, performed during test values were all within +/-5% of the 835 MHz Target value.

At 900 MHz were the probe was calibrated and validation performed, the tissue dielectric parameter measured for routine measurements at 900 MHz was less than the target parameter for 835 MHz ϵ and higher than the target parameter for 835 MHz σ .

frequency(MHz)	Measured Fluid Parameter Date: 28/09/2009		Measured Fluid Parameter Date: 30/09/2009		Target / Nominal Fluid Parameter used by System manufacturer in cal certificate	
	ϵ	σ	ϵ	σ	ϵ	σ
800	54.08	0.93	54.42	0.93	52.30	0.92
805	54.04	0.94	54.38	0.93	52.71	0.93
810	53.99	0.94	54.34	0.93	53.13	0.93
815	53.95	0.95	54.30	0.94	53.54	0.94
820	53.90	0.95	54.26	0.94	53.96	0.95
825	53.86	0.96	54.22	0.95	54.37	0.96
830	53.81	0.96	54.17	0.95	54.79	0.96
835	53.77	0.97	54.13	0.96	55.20	0.97
840	53.72	0.97	54.09	0.96	55.18	0.98
845	53.68	0.98	54.05	0.97	55.17	0.98
850	53.63	0.98	54.01	0.97	55.15	0.99
900	53.17	1.06	53.53	1.03	55.00	1.05

Test of: Dell Latitude E4200 Notebook PC

To: OET Bulletin 65 Supplement C: (2001-01)

Permittivity Indicating +/-5% tolerance

— Measured Fluid Parameter Date: 28/09/2009
— Measured Fluid Parameter Date: 30/09/2009
— Nominal Fluid Parameter used by System manufacturer in cal certificate

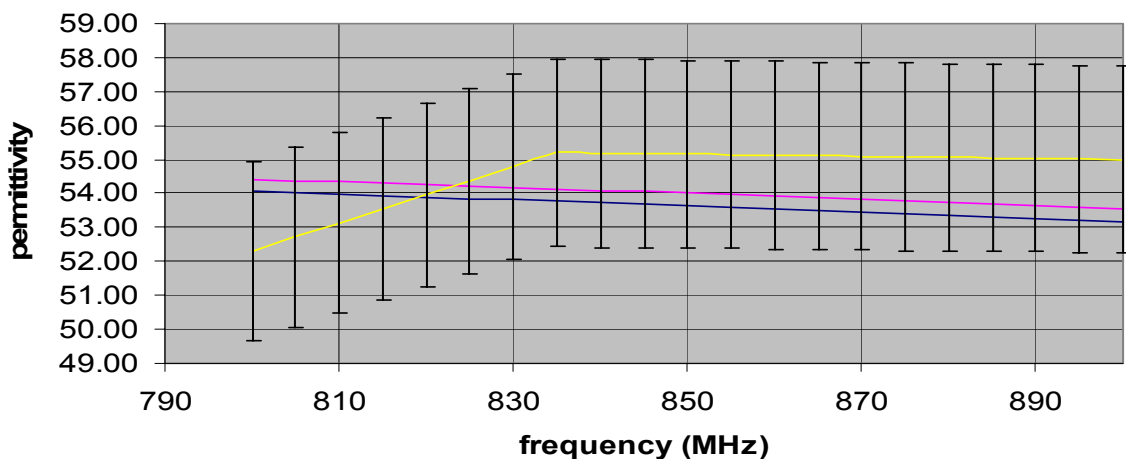

Conductivity Indicating +/-5% tolerance

— Measured Fluid Parameter Date: 28/09/2009
— Measured Fluid Parameter Date: 30/09/2009
— Nominal Fluid Parameter used by System manufacturer in cal certificate

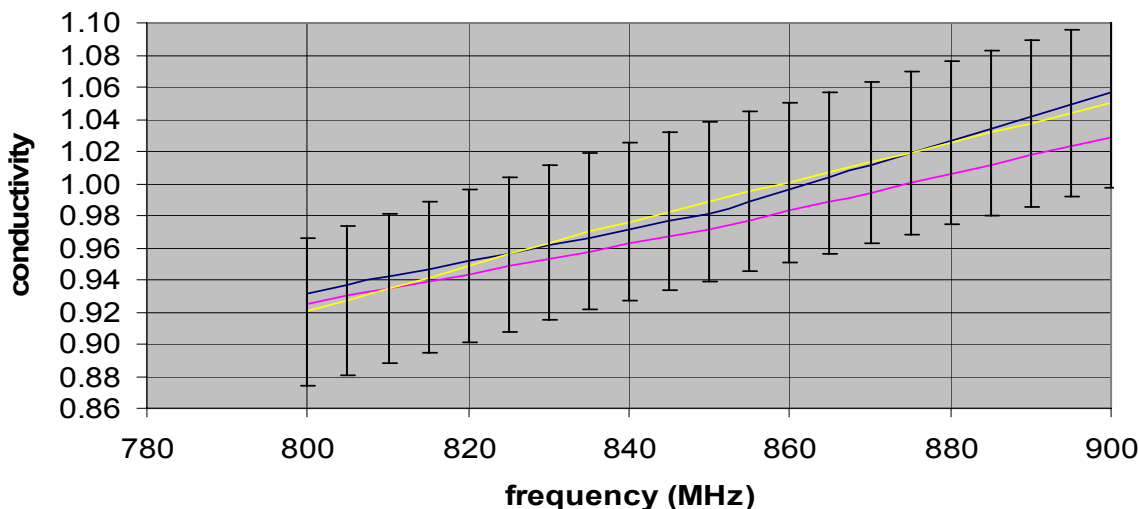

Test of: **Dell Latitude E4200 Notebook PC**

To: **OET Bulletin 65 Supplement C: (2001-01)**

The probe conversion factor and its frequency response, with respect to the tissue dielectric media used during the probe calibration and routine measurements was examined to determine if the effective frequency interval is adequate for the intended measurements to satisfy protocol requirements. The frequency range at which the probe is calibrated for at 900 MHz covered 800 MHz to 1000 MHz and the dielectric parameters required for 824 to 840 MHz were all within the calibrated range of the probe dielectric parameters.

Conversion					
Name:	900 (Body)			OK	
	X:	Y:	Z:	Cancel	
Conversion factor:	9.99	9.99	9.99		
Alpha:	0.45	0.45	0.45		
Delta:	0.75	0.75	0.75		
Frequency range:	800	to	1000	MHz	Calibrated for: 900 MHz
Permittivity range:	52.3	to	57.8		Calibrated for: 55
Conductivity range:	0.92	to	1.1	S/m	Calibrated for: 1.05 S/m

The measurement within the required frequency interval satisfy an expanded probe calibration uncertainty ($k=2$) $\leq 15\%$ for all measurement conditions. Please refer to probe and dipole calibration certificates produce by the system manufacturer.

Sensitivity in Tissue Simulating Liquid (Conversion Factors)

Please see Page 8.

Boundary Effect

TSL	900 MHz	Typical SAR gradient: 5 % per mm	
	Sensor Center to Phantom Surface Distance	2.0 mm	3.0 mm
	SAR _{be} [%] Without Correction Algorithm	7.8	4.6
	SAR _{be} [%] With Correction Algorithm	0.5	0.3
TSL	1750 MHz	Typical SAR gradient: 10 % per mm	
	Sensor Center to Phantom Surface Distance	2.0 mm	3.0 mm
	SAR _{be} [%] Without Correction Algorithm	5.8	2.7
	SAR _{be} [%] With Correction Algorithm	0.7	0.5

Sensor Offset

Probe Tip to Sensor Center **1.0 mm**

The reported uncertainty of measurement is stated as the standard uncertainty of measurement multiplied by the coverage factor $k=2$, which for a normal distribution corresponds to a coverage probability of approximately 95%.

Test of: Dell Latitude E4200 Notebook PC

To: OET Bulletin 65 Supplement C: (2001-01)

Appendix 6. Simulated Tissues

The body mixture consists of water and glycol. Visual inspection is made to ensure air bubbles are not trapped during the mixing process. The mixture is calibrated to obtain proper dielectric constant (permittivity) and conductivity of the tissue.

Ingredient	Frequency
	1800/1900 MHz Body
De-Ionised Water	69.79%
Diglycol Butyl Ether (DGBE)	30.00%
Salt	0.20%

ngredient	Frequency
	835/850/900 MHz Body
De-Ionised Water	50.75%
Sugar	48.21%
Salt	0.94%
Kathon	0.10%

Test of: Dell Latitude E4200 Notebook PC**To: OET Bulletin 65 Supplement C: (2001-01)**

Appendix 7. DASY4 System Details

A.7.1. DASY4 SAR Measurement System

RFI Global Services Ltd, SAR measurement facility utilises the Dosimetric Assessment System (DASY™) manufactured by Schmid & Partner Engineering AG (SPEAG™) of Zurich, Switzerland. The DASY4 system is comprised of the robot controller, computer, near-field probe, probe alignment sensor, and the SAM phantom containing brain or muscle equivalent material. The robot is a six-axis industrial robot performing precise movements to position the probe to the location (points) of maximum electromagnetic field (EMF). A cell controller system contains the power supply, robot controller; teach pendant (Joystick), and remote control. This is used to drive the robot motors. The Staubli robot is connected to the cell controller to allow software manipulation of the robot. The data acquisition electronics (DAE) performs signal amplification, signal multiplexing, AD-conversion, offset measurements, mechanical surface detection, collision detection etc. The DAE is connected to the Electro-optical coupler (EOC). The EOC performs the conversion from the optical into digital electric signal of the DAE and transfers data to the PC plug-in card. The DAE3 utilises a highly sensitive electrometer-grade preamplifier with auto-zeroing, a channel and gain-switching multiplexer, a fast 16-bit AD-converter and a command decoder and control logic unit. Transmission to the PC-card is accomplished through an optical downlink for data and status information and an optical uplink for commands and clock lines. The mechanical probe-mounting device includes two different sensor systems for frontal and sidewise probe contacts. They are also used for mechanical surface detection and probe collision detection. The robot uses its own controller with a built in VME-bus computer.

Test of: Dell Latitude E4200 Notebook PC

To: OET Bulletin 65 Supplement C: (2001-01)

A.7.2. DASY4 SAR System Specifications**Robot System**

Positioner:	Stäubli Unimation Corp. Robot Model: RX90L
Repeatability:	0.025 mm
No. of Axis:	6
Serial Number:	F00/SD89A1/A/01
Reach:	1185 mm
Payload:	3.5 kg
Control Unit:	CS7
Programming Language:	V+

Data Acquisition Electronic (DAE) System

Serial Number:	DAE3 SN:450
-----------------------	-------------

PC Controller

PC:	Dell Precision 340
Operating System:	Windows 2000
Data Card:	DASY4 Measurement Server
Serial Number:	1080

Data Converter

Features:	Signal Amplifier, multiplexer, A/D converted and control logic.
Software:	DASY4 Software
Connecting Lines:	Optical downlink for data and status info. Optical uplink for commands and clock.

PC Interface Card

Function:	24 bit (64 MHz) DSP for real time processing Link to DAE3 16 nit A/D converter for surface detection system serial link to robot direct emergency stop output for robot.
------------------	--

Test of: Dell Latitude E4200 Notebook PC

To: OET Bulletin 65 Supplement C: (2001-01)

DASY4 SAR System Specifications (Continued)**E-Field Probe**

Model:	EX3DV3
Serial No:	3508
Construction:	Triangular core
Frequency:	10 MHz to >6 GHz
Linearity:	±0.2 dB (30 MHz to 6 GHz)
Probe Length (mm):	330
Probe Diameter (mm):	12
Tip Length (mm):	20
Tip Diameter (mm):	2.5
Sensor X Offset (mm):	1
Sensor Y Offset (mm):	1
Sensor Z Offset (mm):	1

Phantom

Phantom:	OVAL Phantom
Shell Material:	Fibreglass
Thickness:	2.0 ±0.1 mm
