

YF INTERNATIONAL LIMITED	
Title	GPS_MODEL_84T
Size	Document Number
B	内存部分电路原理图
Date:	Tuesday, December 30, 2008
Sheet	3 of 16
Rev	V1

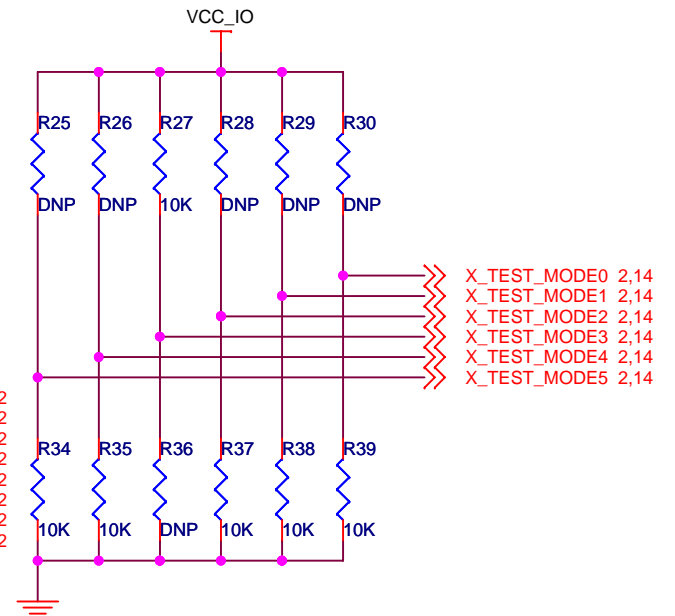
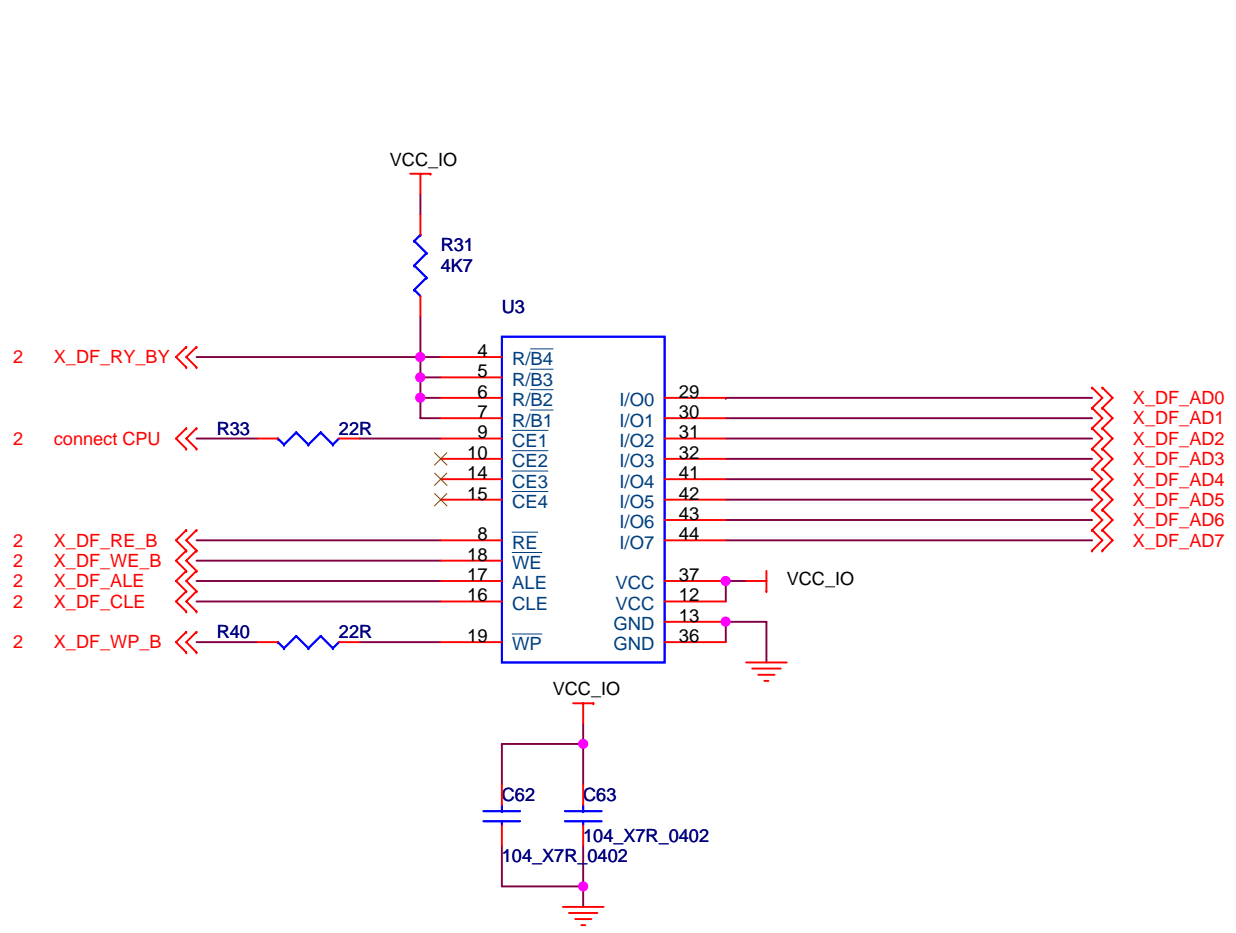

### Boot Configure for three options

Boot configuration	X_TEST_MODE[5:0]
Boundary Scan	6b110000
SLC Nand Boot 2KB Page 8 Bit	6b000101
<b>MLC Nand Boot 2KB Page 8 Bit(Default)</b>	<b>6b001000</b>
INAND Boot	6b001100
EFuse	6b110010

YF INTERNATIONAL LIMITED		
Title GPS_MODEL_84T		
Size Custom	Document Number FLASH部分电路原理图	Rev V1
Date: Wednesday, December 31, 2008	Sheet 4	of 16

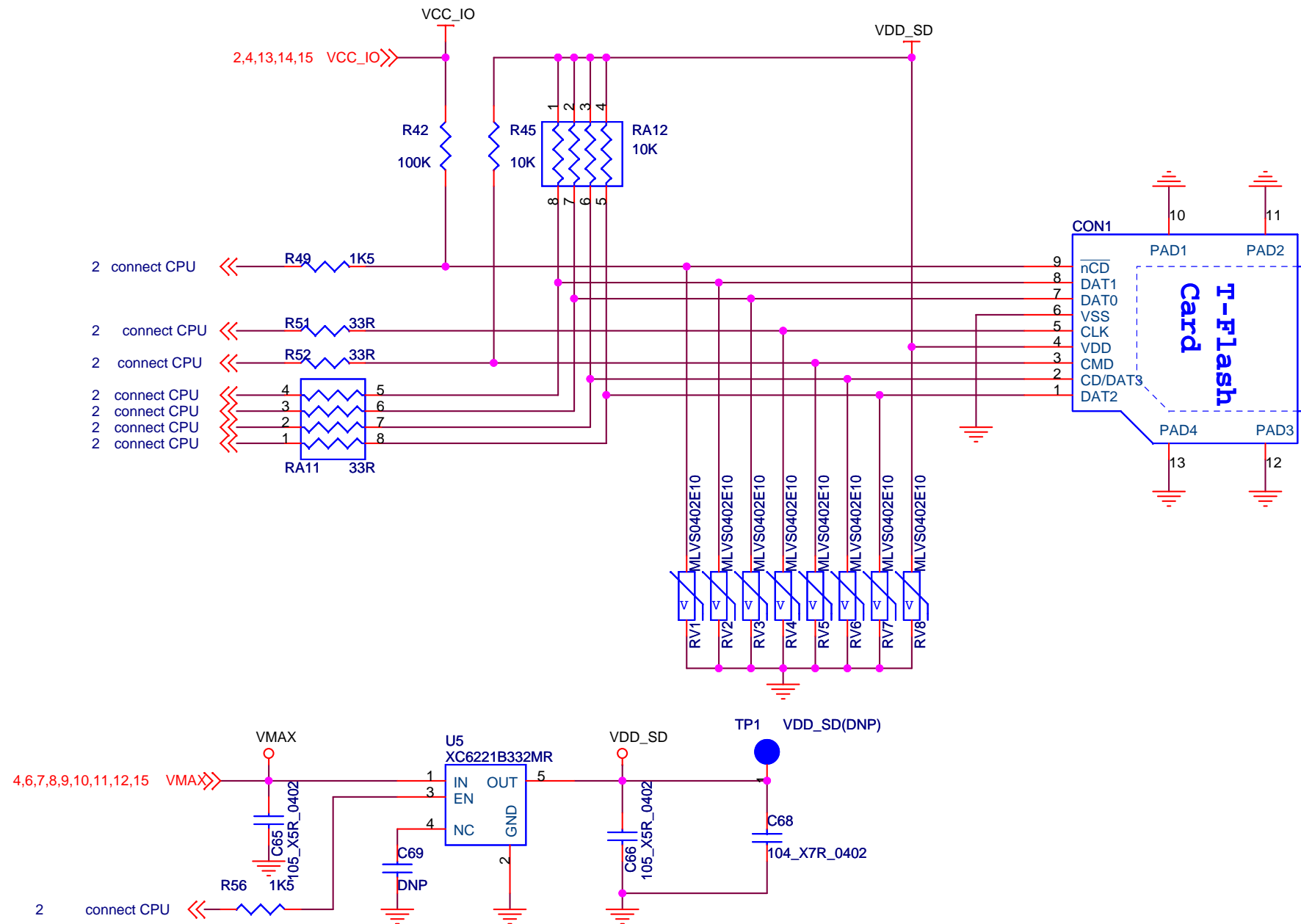

YF INTERNATIONAL LIMITED		
Title GPS_MODEL_84T		
Size A	Document Number T-FLASH部分电路原理图	Rev V1
Date:	Wednesday, December 31, 2008	Sheet 5 of 16

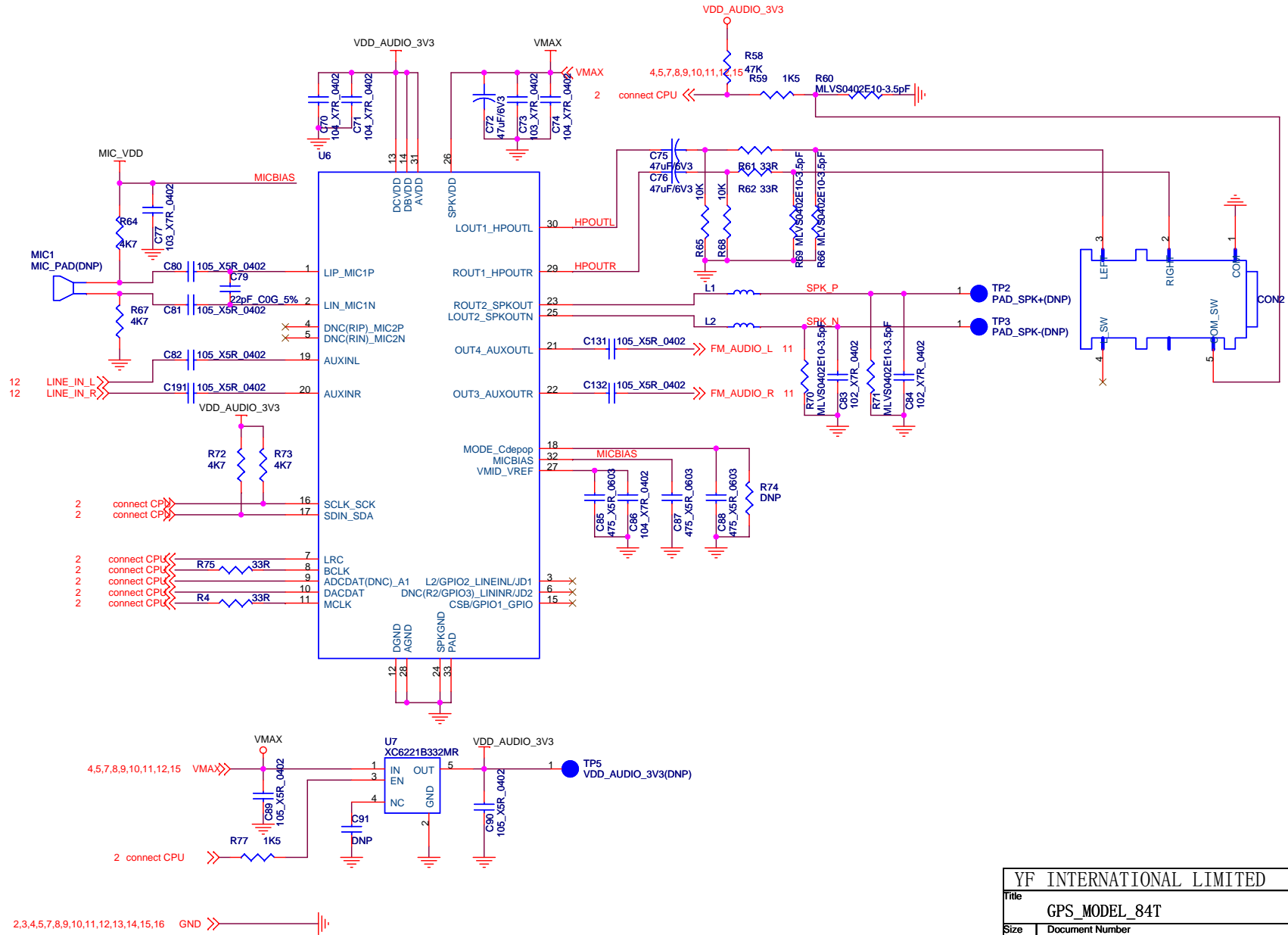

YF INTERNATIONAL LIMITED		
Title		
GPS_MODEL_84T		
Size	Document Number	Rev
B	音频部分电路原理图	V1
Date:	Wednesday, December 31, 2008	Sheet 6 of 16

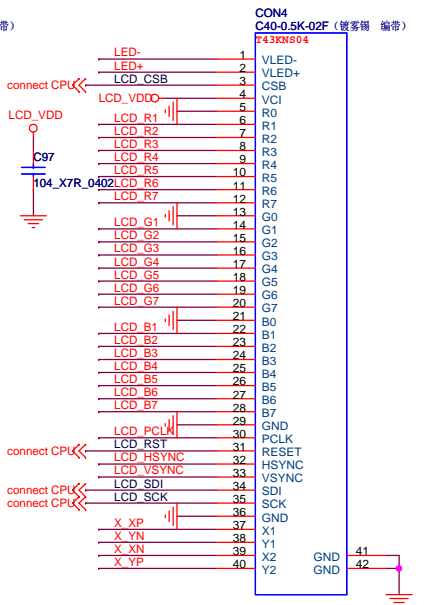
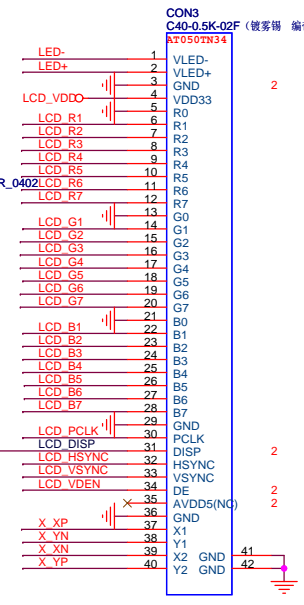
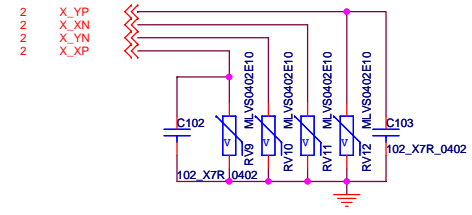
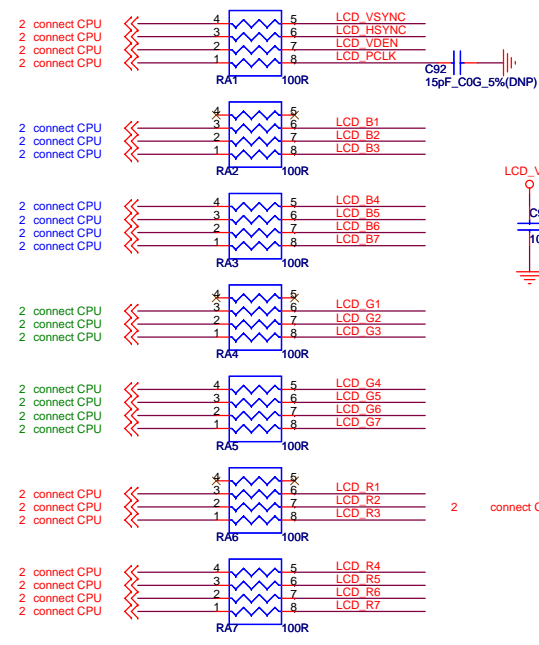
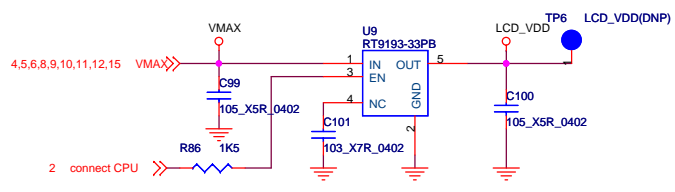
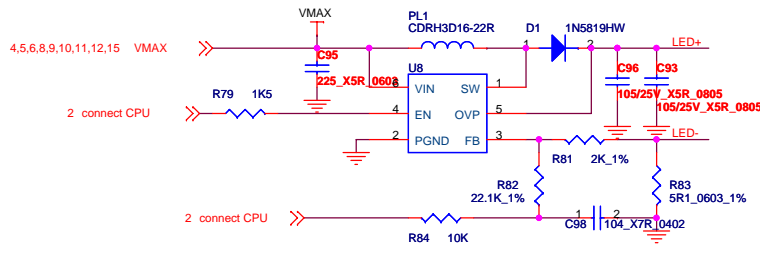

YF INTERNATIONAL LIMITED			
File GPS_MODEL_84T			
Size	Document Number	Rev V1	
Customer	LCD部分电路原理图		
Date:	Wednesday, December 31, 2008	Sheet	7 of 16

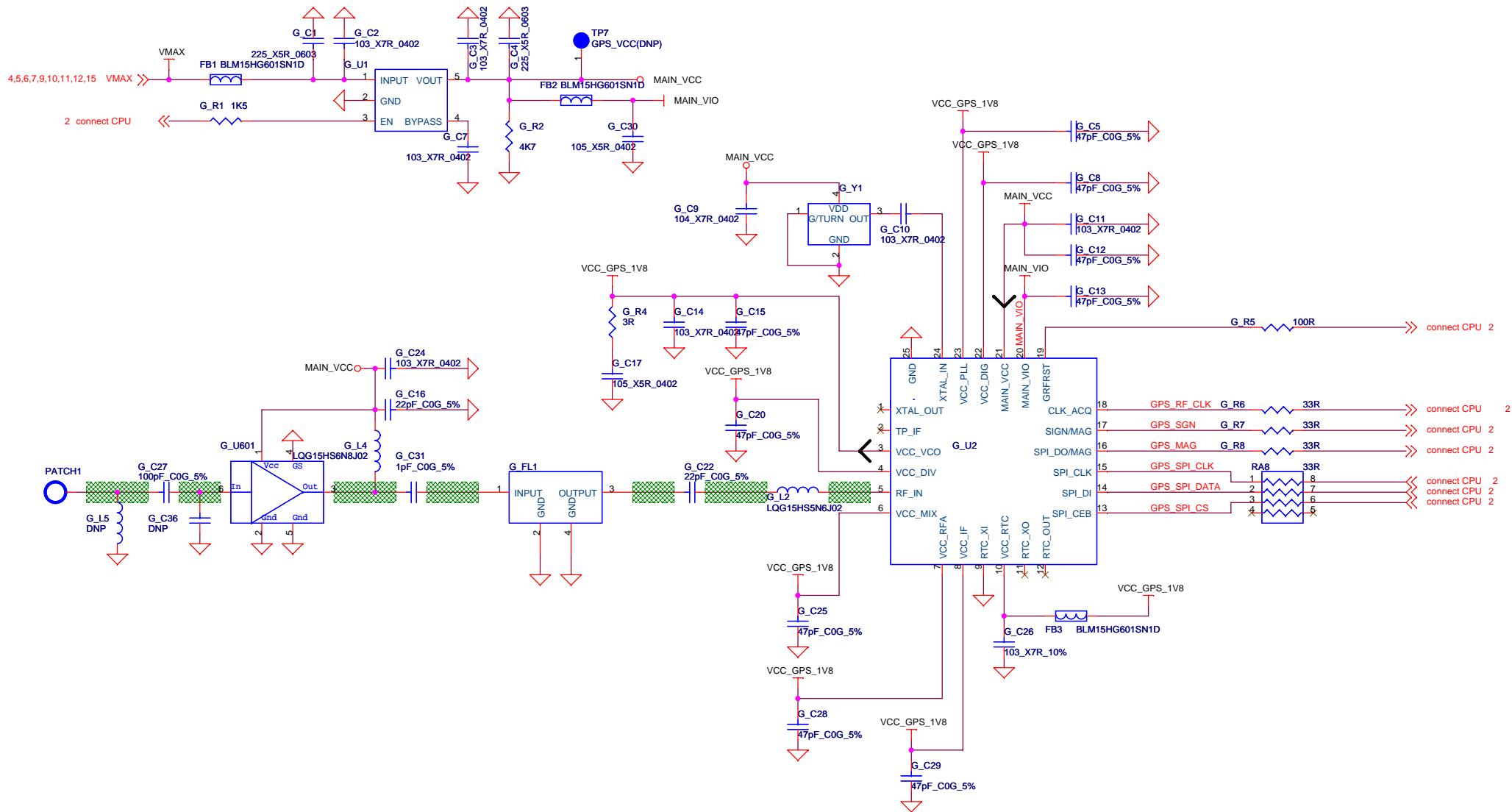

YF INTERNATIONAL LIMITED		
Title GPS_MODEL_84T		
Size Custom	Document Number GPS RF部分电路原理图	Rev V1
Date: Tuesday, December 30, 2008	Sheet 8	of 16

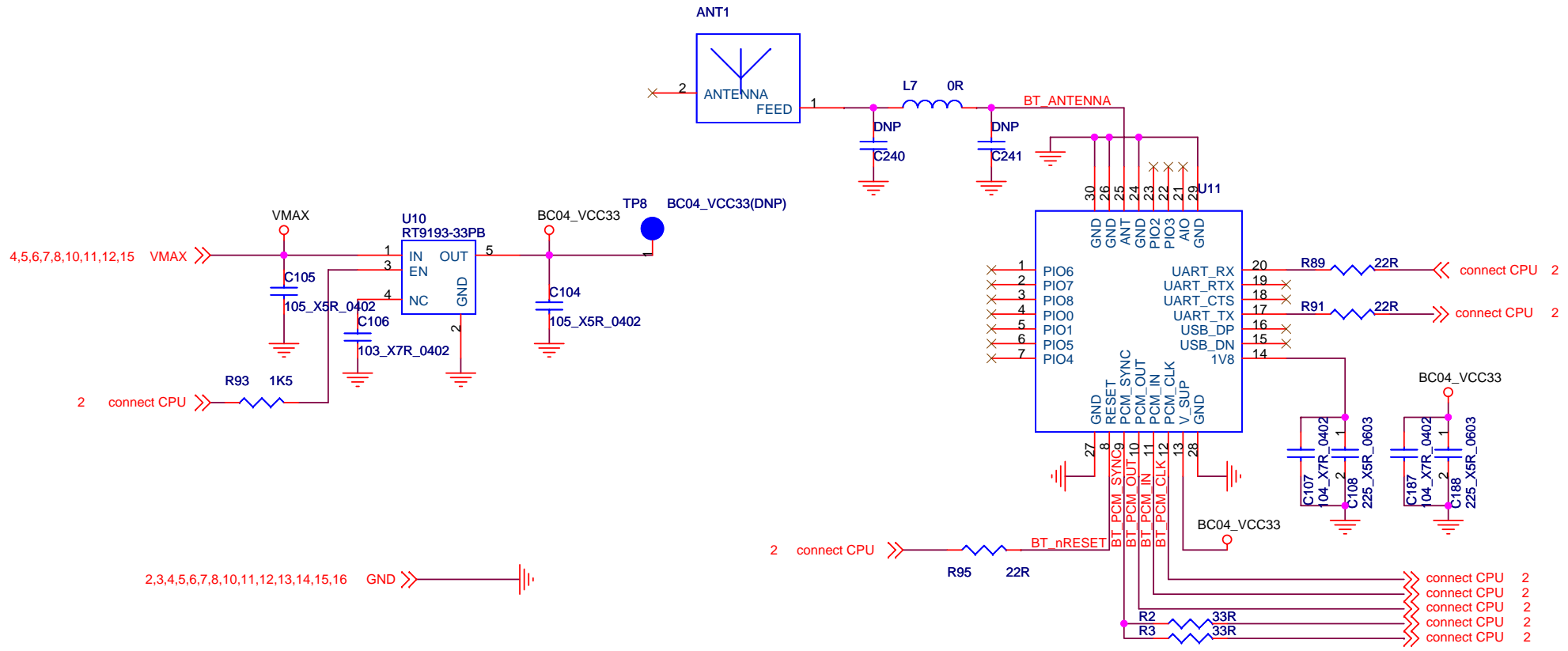

YF INTERNATIONAL LIMITED		
Title		
GPS_MODEL_84T		
Size	Document Number	Rev
Custom	蓝牙部分电路原理图	V1
Date:	Wednesday, December 31, 2008	Sheet 9 of 16



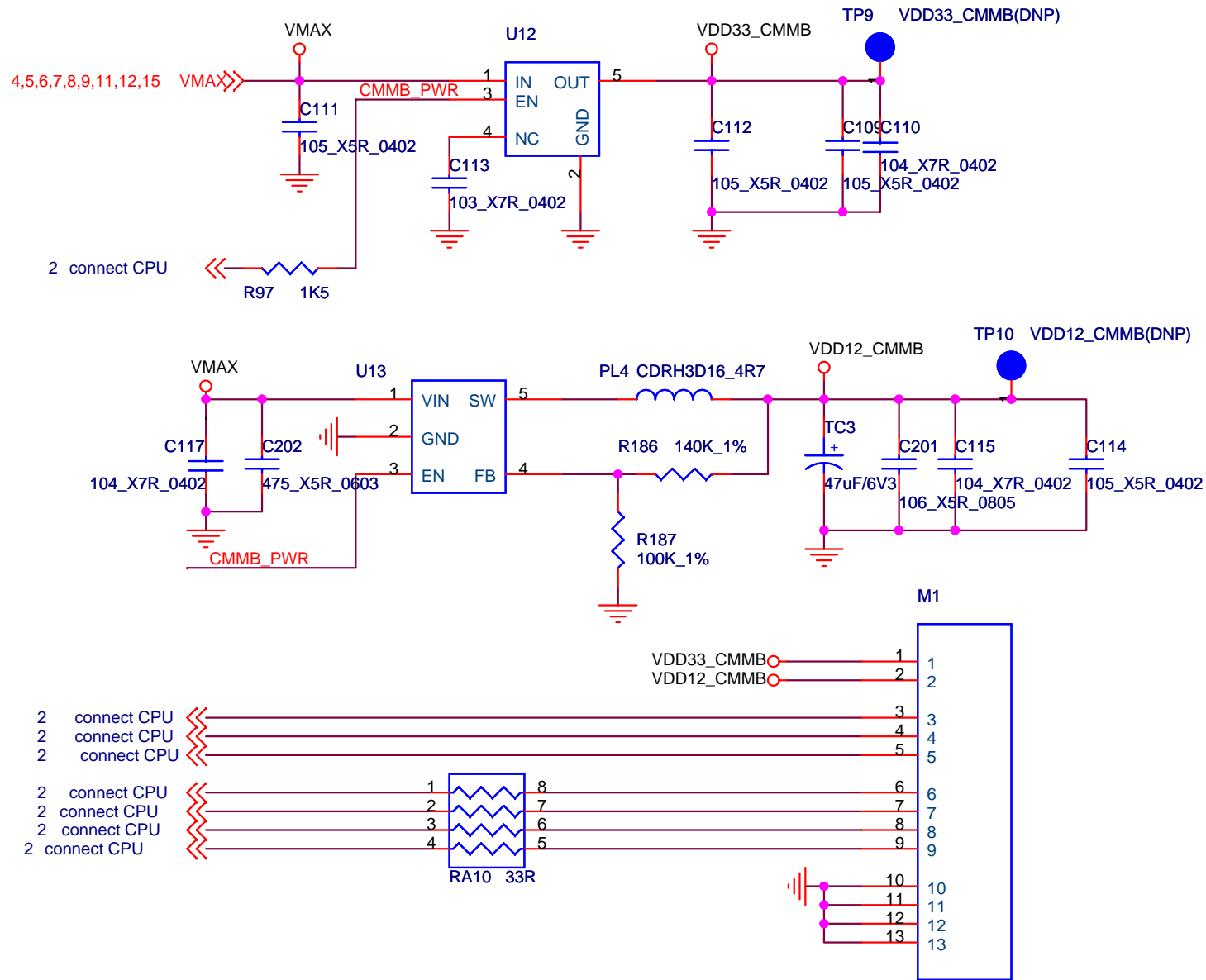

YF INTERNATIONAL LIMITED

Title

GPS\_MODEL\_84T

Size

Document Number

Custom

CMMB部分电路原理图

Rev

V1

Date:

Wednesday, December 31, 2008

Sheet

10

of

16

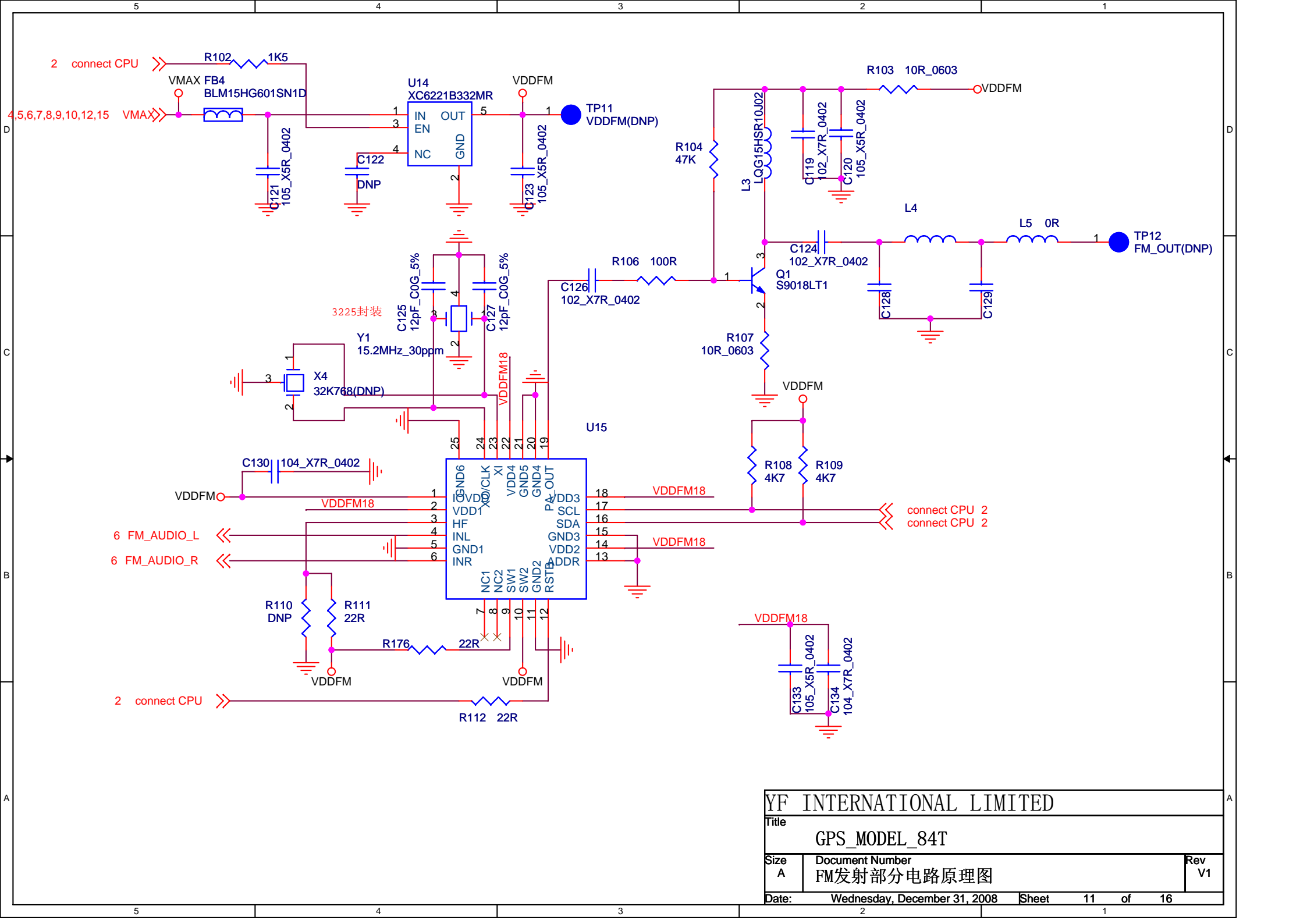

YF INTERNATIONAL LIMITED		
Title		
GPS_MODEL_84T		
Size	Document Number	Rev
A	FM发射部分电路原理图	V1
Date:	Wednesday, December 31, 2008	Sheet 11 of 16

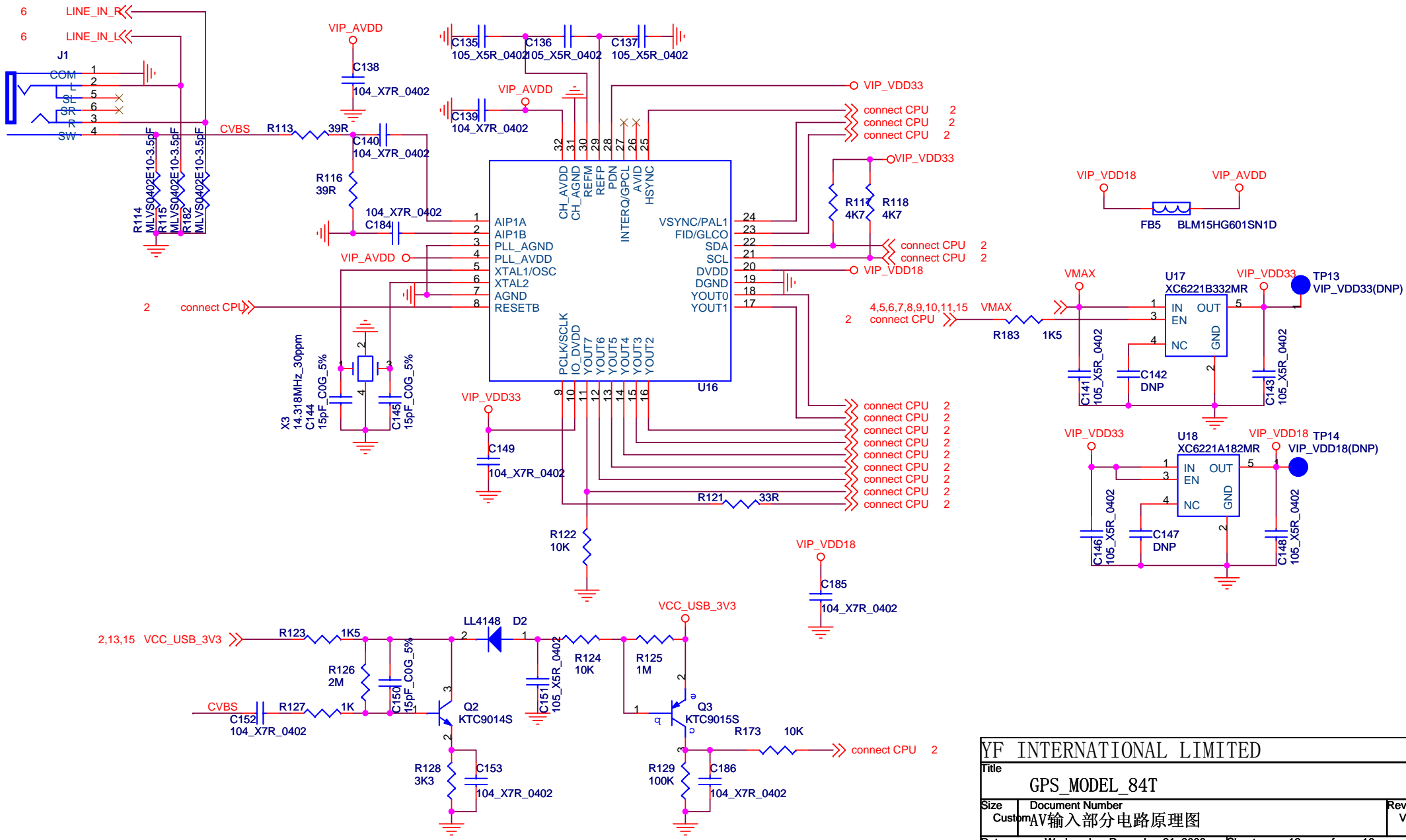

YF INTERNATIONAL LIMITED		
Title		
GPS_MODEL_84T		
Size	Document Number	Rev
Custom	AV输入部分电路原理图	V1
Date:	Wednesday, December 31, 2008	Sheet 12 of 16

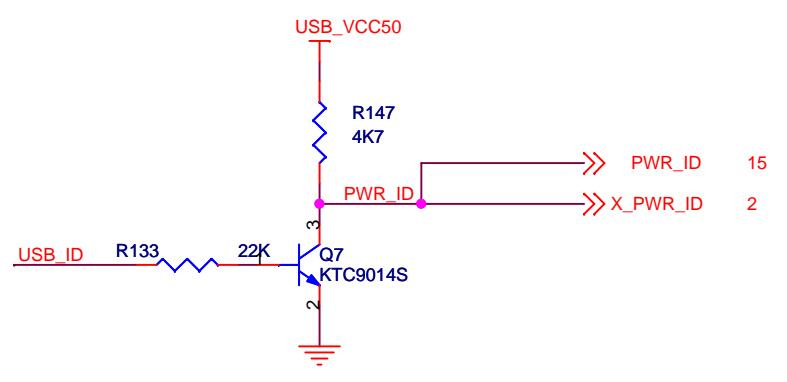
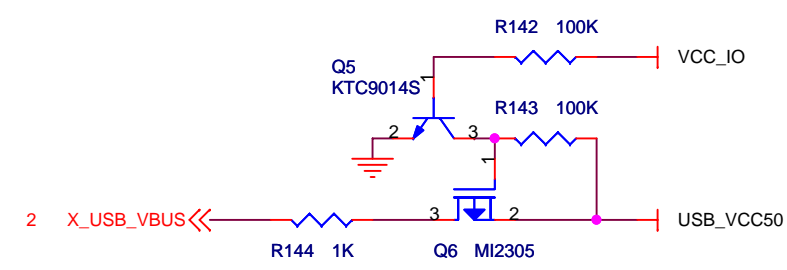
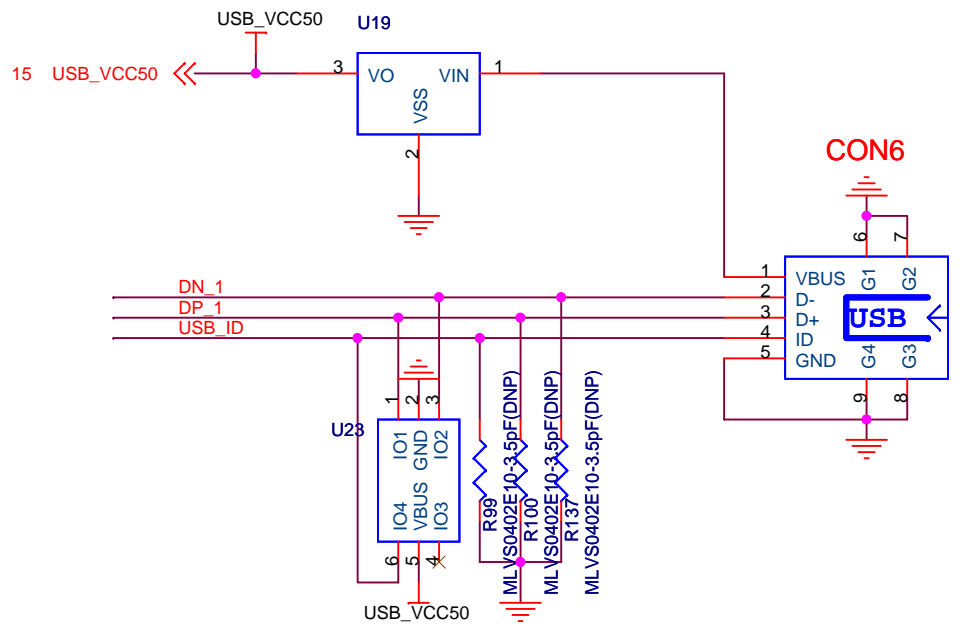
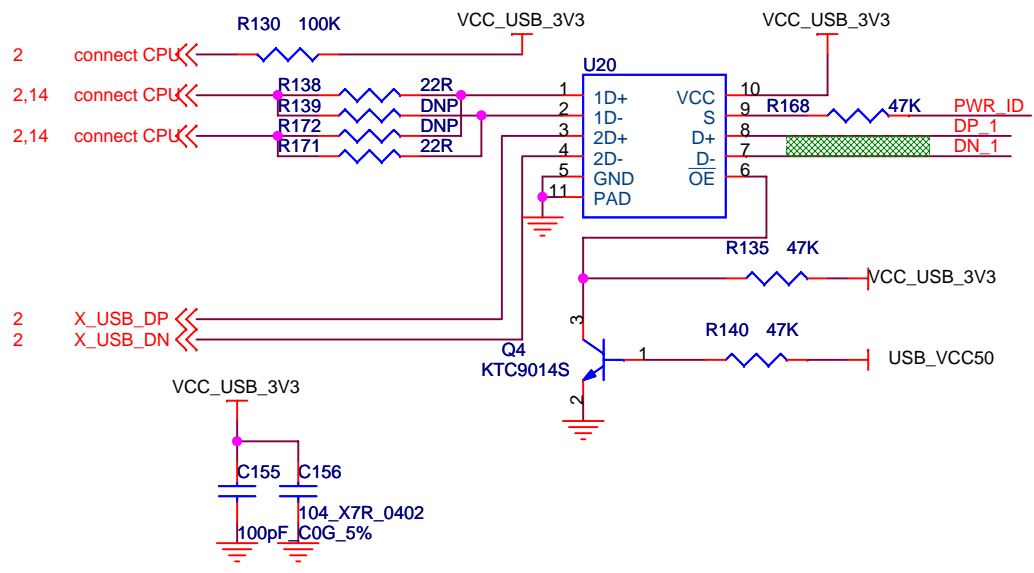

YF INTERNATIONAL LIMITED			
Title GPS_MODEL_84T			
Size Custom	Document Number USB_DEVICE部分电路原理图		Rev V1
Date:	Wednesday, December 31, 2008	Sheet	13 of 16

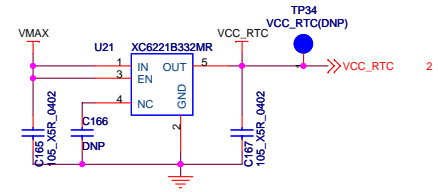
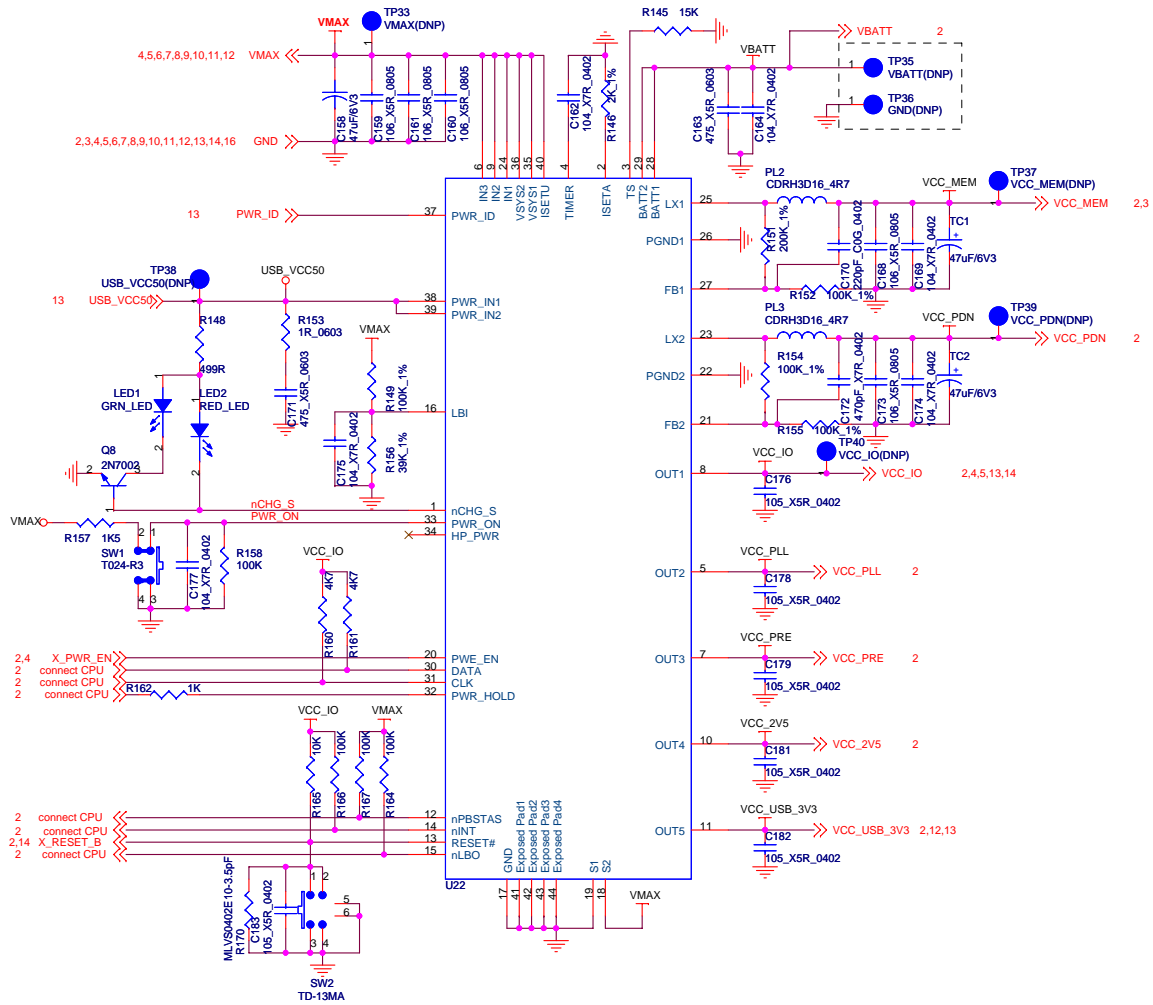

YF INTERNATIONAL LIMITED			
Title GPS_MODEL_84T			
Size	Document Number	Rev	
Custom	电源管理部分电路原理图	V1	
Date:	Wednesday, December 31, 2008	Sheet	15 of 16