



# SPORTON International Inc.

No. 52, Hwa Ya 1st Rd., Kwei-Shan Hsiang, TaoYuan Hsien, Taiwan, R.O.C.  
Ph: 886-3-327-3456 / FAX: 886-3-327-0973 / www.sporton.com.tw

## FCC RADIO TEST REPORT

Applicant's company	PEGATRON CORPORATION
Applicant Address	5F., NO. 76, LIGONG ST., BEITOU DISTRICT, TAIPEI CITY 112 Taiwan
FCC ID	VUIUPWL6031H2
Manufacturer's company	PEGATRON CORPORATION
Manufacturer Address	5F., NO. 76, LIGONG ST., BEITOU DISTRICT, TAIPEI CITY 112 Taiwan

Product Name	Wireless module
Brand Name	PEGATRON
Model Name	UPWL6031H2
Test Rule	47 CFR FCC Part 15 Subpart C § 15.247
Test Freq. Range	2400 ~ 2483.5MHz
Received Date	Dec. 13, 2012
Final Test Date	Dec. 31, 2012
Submission Type	Original Equipment

### Statement

**Test result included in this report is for the IEEE 802.11n and IEEE 802.11b/g part of the product.**

The test result in this report refers exclusively to the presented test model / sample.

Without written approval of SPORTON International Inc., the test report shall not be reproduced except in full.

The measurements and test results shown in this test report were made in accordance with the procedures and found in compliance with the limit given in **ANSI C63.10-2009, 47 CFR FCC Part 15 Subpart C, KDB 558074 D01 v02 and KDB 662911 D01 v01r02.**

The test equipment used to perform the test is calibrated and traceable to NML/ROC.



## Table of Contents

<b>1. CERTIFICATE OF COMPLIANCE .....</b>	<b>1</b>
<b>2. SUMMARY OF THE TEST RESULT .....</b>	<b>2</b>
<b>3. GENERAL INFORMATION .....</b>	<b>3</b>
3.1. Product Details.....	3
3.2. Accessories.....	5
3.3. Table for Filed Antenna.....	5
3.4. Table for Carrier Frequencies .....	6
3.5. Table for Test Modes .....	7
3.6. Table for Testing Locations.....	7
3.7. Table for Supporting Units .....	8
3.8. Table for Parameters of Test Software Setting .....	8
3.9. Test Configurations .....	9
<b>4. TEST RESULT .....</b>	<b>12</b>
4.1. AC Power Line Conducted Emissions Measurement.....	12
4.2. Maximum Conducted Output Power Measurement.....	16
4.3. Power Spectral Density Measurement .....	19
4.4. 6dB Spectrum Bandwidth Measurement .....	25
4.5. Radiated Emissions Measurement .....	30
4.6. Band Edge Emissions Measurement .....	48
4.7. Antenna Requirements .....	61
<b>5. LIST OF MEASURING EQUIPMENTS .....</b>	<b>62</b>
<b>6. TEST LOCATION.....</b>	<b>64</b>
<b>APPENDIX A. TEST PHOTOS .....</b>	<b>A1 ~ A6</b>
<b>APPENDIX B. MAXIMUM PERMISSIBLE EXPOSURE .....</b>	<b>B1 ~ B3</b>



## History of This Test Report

REPORT NO.	VERSION	DESCRIPTION	ISSUED DATE
FR2N3007	Rev. 01	Initial issue of report	Jan. 14, 2013



## 1. CERTIFICATE OF COMPLIANCE

Product Name : Wireless module  
Brand Name : PEGATRON  
Model Name : UPWL6031H2  
Applicant : PEGATRON CORPORATION  
Test Rule Part(s) : 47 CFR FCC Part 15 Subpart C § 15.247

Sporton International as requested by the applicant to evaluate the EMC performance of the product sample received on Dec. 13, 2012 would like to declare that the tested sample has been evaluated and found to be in compliance with the tested rule parts. The data recorded as well as the test configuration specified is true and accurate for showing the sample's EMC nature.

*Sam Chen*

Sam Chen

SPORTON INTERNATIONAL INC.

## 2. SUMMARY OF THE TEST RESULT

Applied Standard: 47 CFR FCC Part 15 Subpart C				
Part	Rule Section	Description of Test	Result	Under Limit
4.1	15.207	AC Power Line Conducted Emissions	Complies	17.89 dB
4.2	15.247(b)(3)	Maximum Conducted Output Power	Complies	2.22 dB
4.3	15.247(e)	Power Spectral Density	Complies	7.5 dB
4.4	15.247(a)(2)	6dB Spectrum Bandwidth	Complies	-
4.5	15.247(d)	Radiated Emissions	Complies	0.46 dB
4.6	15.247(d)	Band Edge Emissions	Complies	0.04 dB
4.7	15.203	Antenna Requirements	Complies	-

Test Items	Uncertainty	Remark
AC Power Line Conducted Emissions	±2.3dB	Confidence levels of 95%
Maximum Conducted Output Power	±0.8dB	Confidence levels of 95%
Power Spectral Density	±0.5dB	Confidence levels of 95%
6dB Spectrum Bandwidth	±8.5×10 <sup>-8</sup>	Confidence levels of 95%
Radiated Emissions (9kHz~30MHz)	±0.8dB	Confidence levels of 95%
Radiated Emissions (30MHz~1000MHz)	±1.9dB	Confidence levels of 95%
Radiated / Band Edge Emissions (1GHz~18GHz)	±1.9dB	Confidence levels of 95%
Radiated Emissions (18GHz~40GHz)	±1.9dB	Confidence levels of 95%
Temperature	±0.7°C	Confidence levels of 95%
Humidity	±3.2%	Confidence levels of 95%
DC / AC Power Source	±1.4%	Confidence levels of 95%

### 3. GENERAL INFORMATION

#### 3.1. Product Details

##### IEEE 802.11n

Items	Description
Product Type	WLAN (3TX, 3RX)
Radio Type	Intentional Transceiver
Power Type	From Host System
Modulation	see the below table for IEEE 802.11n
Data Modulation	OFDM (BPSK / QPSK / 16QAM / 64QAM)
Data Rate (Mbps)	see the below table for IEEE 802.11n
Frequency Range	2400 ~ 2483.5MHz
Channel Number	11 for 20MHz bandwidth ; 7 for 40MHz bandwidth
Channel Band Width (99%)	MCS0 (20MHz): 18.24 MHz ; MCS0 (40MHz): 35.36 MHz
Maximum Conducted Output Power	MCS0 (20MHz): 27.78 dBm ; MCS0 (40MHz): 23.41 dBm
Carrier Frequencies	Please refer to section 3.4
Antenna	Please refer to section 3.3

##### IEEE 802.11b/g

Items	Description
Product Type	802.11b/g :WLAN (1TX, 3RX)
Radio Type	Intentional Transceiver
Power Type	From Host System
Modulation	DSSS for IEEE 802.11b ; OFDM for IEEE 802.11g
Data Modulation	DSSS (BPSK / QPSK / CCK) ; OFDM (BPSK / QPSK / 16QAM / 64QAM)
Data Rate (Mbps)	DSSS (1/ 2/ 5.5/11) ; OFDM (6/9/12/18/24/36/48/54)
Frequency Range	2400 ~ 2483.5MHz
Channel Number	11
Channel Band Width (99%)	11b: 12.32 MHz ; 11g: 17.44 MHz
Maximum Conducted Output Power	11b: 26.21 dBm ; 11g: 24.02 dBm
Carrier Frequencies	Please refer to section 3.4
Antenna	Please refer to section 3.3

**Antenna & Band width**

Antenna	Single (TX)		Three (TX)	
	20 MHz	40 MHz	20 MHz	40 MHz
IEEE 802.11b	V	X	X	X
IEEE 802.11g	V	X	X	X
IEEE 802.11n	X	X	V	V

**IEEE 802.11n spec**
**IEEE 802.11n spec**

MCS index	Spatial streams	Modulation type	Coding rate	Data rate (Mbit/s)			
				20 MHz channel		40 MHz channel	
				800 ns GI	400 ns GI	800 ns GI	400 ns GI
0	1	BPSK	1/2	6.5	7.2	13.5	15
1	1	QPSK	1/2	13	14.4	27	30
2	1	QPSK	3/4	19.5	21.7	40.5	45
3	1	16-QAM	1/2	26	28.9	54	60
4	1	16-QAM	3/4	39	43.3	81	90
5	1	64-QAM	2/3	52	57.8	108	120
6	1	64-QAM	3/4	58.5	65	121.5	135
7	1	64-QAM	5/6	65	72.2	135	150
8	2	BPSK	1/2	13	14.4	27	30
9	2	QPSK	1/2	26	28.9	54	60
10	2	QPSK	3/4	39	43.3	81	90
11	2	16-QAM	1/2	52	57.8	108	120
12	2	16-QAM	3/4	78	86.7	162	180
13	2	64-QAM	2/3	104	115.6	216	240
14	2	64-QAM	3/4	117	130	243	270
15	2	64-QAM	5/6	130	144.4	270	300
16	3	BPSK	1/2	19.5	21.7	40.5	45
17	3	QPSK	1/2	39	43.3	81	90
18	3	QPSK	3/4	58.5	65	121.5	135
19	3	16-QAM	1/2	78	86.7	162	180
20	3	16-QAM	3/4	117	130	243	270
21	3	64-QAM	2/3	156	173.3	324	360
22	3	64-QAM	3/4	175.5	195	364.5	405
23	3	64-QAM	5/6	195	216.7	405	450

Symbol	Explanation
NSS	Number of spatial streams
R	Code rate
NBPS	Number of coded bits per single carrier
NCBPS	Number of coded bits per symbol
NDBPS	Number of data bits per symbol
GI	guard interval

### 3.2. Accessories

N/A

### 3.3. Table for Filed Antenna

Chain	Ant.	Brand	Part Number	Antenna Type	Connector	Gain (dBi)	Remark
1	1	WNC	81.EZY15.GBR	PCB	U.FL	3	TX/RX
2	2	WNC	81.EZY15.GBR	PCB	U.FL	3	TX/RX
3	3	WNC	81.EZY15.GBR	PCB	U.FL	3	TX/RX

Note: The EUT has three antennas.

#### For IEEE 802.11b/g mode (1TX/3RX):

Chain 1 can be used as transmitting antenna.

Chain 1, Chain 2 and Chain 3 can be used as receiving antenna.

#### For IEEE 802.11n mode (3TX/3RX):

Chain 1, Chain 2 and Chain 3 will transmit/receive the signal simultaneously.

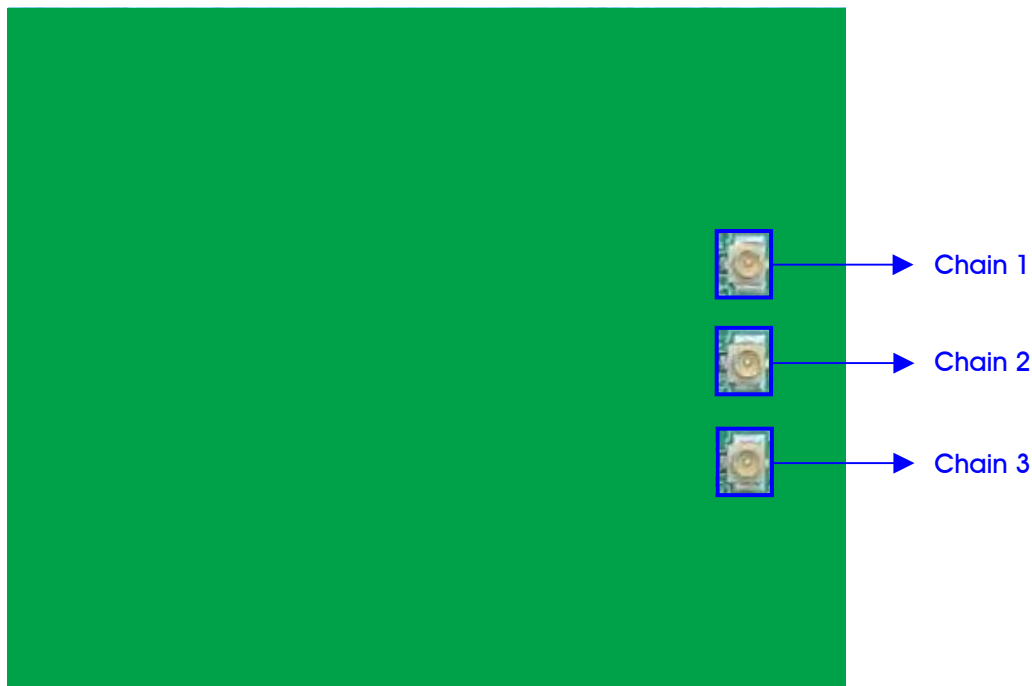



### 3.4. Table for Carrier Frequencies

For IEEE 802.11b/g, use Channel 1~Channel 11.

There are two bandwidth systems for IEEE 802.11n.

For both 20MHz bandwidth systems, use Channel 1~Channel 11.

For both 40MHz bandwidth systems, use Channel 3~Channel 9.

Frequency Band	Channel No.	Frequency	Channel No.	Frequency
2400~2483.5MHz	1	2412 MHz	7	2442 MHz
	2	2417 MHz	8	2447 MHz
	3	2422 MHz	9	2452 MHz
	4	2427 MHz	10	2457 MHz
	5	2432 MHz	11	2462 MHz
	6	2437 MHz	-	-

### 3.5. Table for Test Modes

Preliminary tests were performed in different data rate to find the worst radiated emission. The data rate shown in the table below is the worst-case rate with respect to the specific test item. Investigation has been done on all the possible configurations for searching the worst cases. The following table is a list of the test modes shown in this test report.

Test Items	Mode	Data Rate	Channel	Antenna
AC Power Line Conducted Emissions	Normal Link	-	-	-
Maximum Conducted Output Power	MCS0/20MHz	7.2 Mbps	1/6/11	1/2/3/1+2+3
	MCS0/40MHz	15 Mbps	3/6/9	1/2/3/1+2+3
	11b/CCK	1 Mbps	1/6/11	1
	11g/BPSK	6 Mbps	1/6/11	1
Power Spectral Density	MCS0/20MHz	7.2 Mbps	1/6/11	1/2/3
	MCS0/40MHz	15 Mbps	3/6/9	1/2/3
	11b/CCK	1 Mbps	1/6/11	1
	11g/BPSK	6 Mbps	1/6/11	1
6dB Spectrum Bandwidth	MCS0/20MHz	7.2 Mbps	1/6/11	1+2+3
	MCS0/40MHz	15 Mbps	3/6/9	1+2+3
	11b/CCK	1 Mbps	1/6/11	1
	11g/BPSK	6 Mbps	1/6/11	1
Radiated Emissions Below 1GHz	Normal Link	-	-	-
Radiated Emissions Above 1GHz	MCS0/20MHz	7.2 Mbps	1/6/11	1+2+3
	MCS0/40MHz	15 Mbps	3/6/9	1+2+3
	11b/CCK	1 Mbps	1/6/11	1
	11g/BPSK	6 Mbps	1/6/11	1
Band Edge Emissions	MCS0/20MHz	7.2 Mbps	1/11	1+2+3
	MCS0/40MHz	15 Mbps	3/9	1+2+3
	11b/CCK	1 Mbps	1/11	1
	11g/BPSK	6 Mbps	1/11	1

### 3.6. Table for Testing Locations

Test Site No.	Site Category	Location	FCC Reg. No.	IC File No.
03CH01-CB	SAC	Hsin Chu	262045	IC 4086D
CO01-CB	Conduction	Hsin Chu	262045	IC 4086D
TH01-CB	OVEN Room	Hsin Chu	-	-

Open Area Test Site (OATS); Semi Anechoic Chamber (SAC).

Please refer section 6 for Test Site Address.

### 3.7. Table for Supporting Units

#### <Conducted Emissions>

Support Unit	Brand	Model	FCC ID
Notebook	DELL	E6220	N/A
Earphone	SHYARO CHI	MIC-04	N/A
Wireless AP	BELKIN	WG7016G22-LF-AK	DoC
Mouse	iCooky	AMS0706W	DoC

#### < Radiated Emissions>

Support Unit	Brand	Model	FCC ID
Notebook	DELL	E6220	N/A
Earphone	SHYARO CHI	MIC-04	N/A
Wireless AP	BELKIN	WG7016G22-LF-AK	DoC
Mouse	Logitech	M-U0026	DoC

### 3.8. Table for Parameters of Test Software Setting

During testing, Channel & Power Controlling Software provided by the customer was used to control the operating channel as well as the output power level. The RF output power selection is for the setting of RF output power expected by the customer and is going to be fixed on the firmware of the final end product.

#### Power Parameters of IEEE 802.11n

Test Software Version	Manual Tool : 1.0.0.9		
Frequency	2412 MHz	2437 MHz	2462 MHz
20MHz / MCS0	57	92	52
Frequency	2422 MHz	2437 MHz	2452 MHz
40MHz / MCS0	43	68	64

#### Power Parameters of IEEE 802.11b/g

Test Software Version	Manual Tool : 1.0.0.9		
Frequency	2412 MHz	2437 MHz	2462 MHz
IEEE 802.11b / 1Mbps	88	100	83
IEEE 802.11g / 6Mbps	65	92	59

During the test, "Manual Tool : 1.0.0.9" under WIN XP was executed the test program to control the EUT continuously transmit RF signal.

### 3.9. Test Configurations

#### 3.9.1. Radiation Emissions Test Configuration

Test Configuration: 30MHz~1GHz

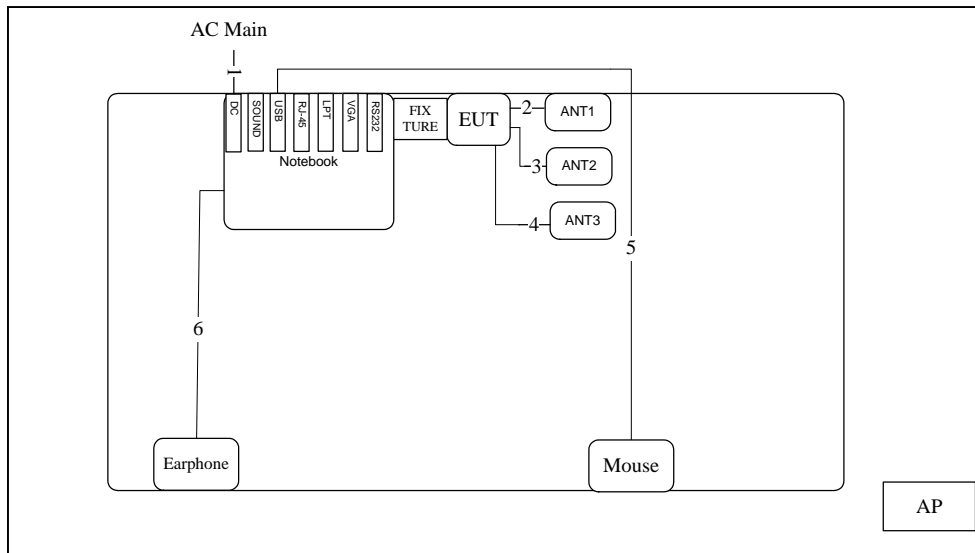

Item	Connection	Shield	Length	Remark
1	Power cable	No	2.6m	-
2	Ant. cable	Yes	0.07m	-
3	Ant. cable	Yes	0.07m	-
4	Ant. cable	Yes	0.07m	-
5	USB cable	No	1.8m	-
6	Audio cable	No	1.2m	-

Test Configuration: above 1GHz

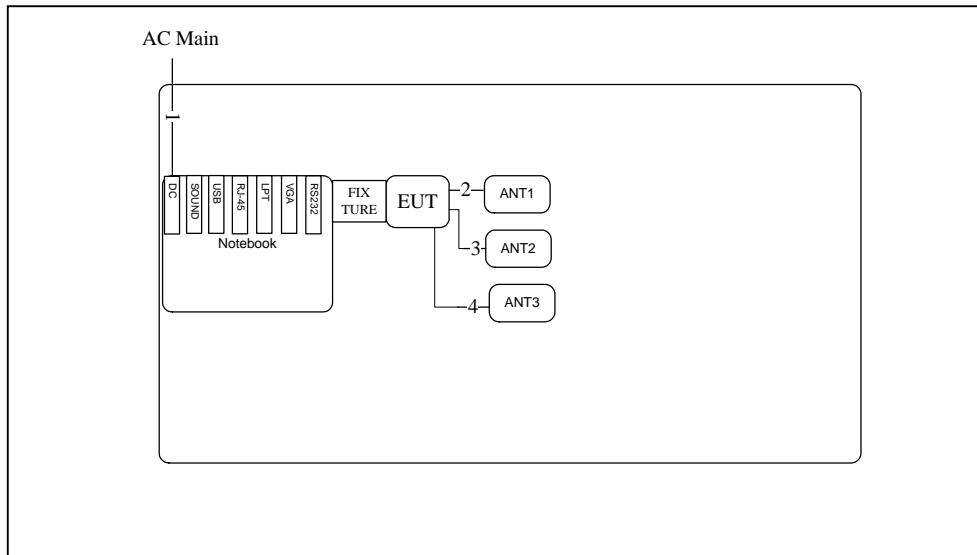

Item	Connection	Shield	Length	Remark
1	Power cable	No	2.6m	-
2	Ant. cable	Yes	0.07m	-
3	Ant. cable	Yes	0.07m	-
4	Ant. cable	Yes	0.07m	-

### 3.9.2. AC Power Line Conduction Emissions Test Configuration

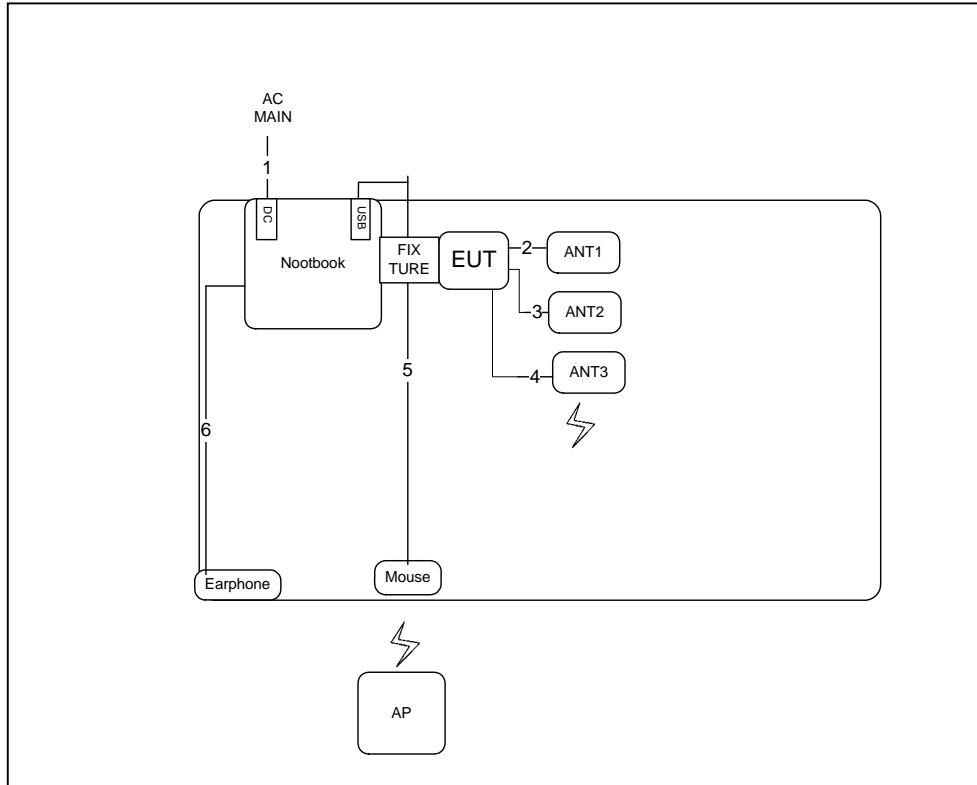

Item	Connection	Shield	Length	Remark
1	Power cable	No	2.6m	-
2	Ant. cable	Yes	0.07m	-
3	Ant. cable	Yes	0.07m	-
4	Ant. cable	Yes	0.07m	-
5	USB cable	No	1.8m	-
6	Audio cable	No	1.2m	-

## 4. TEST RESULT

### 4.1. AC Power Line Conducted Emissions Measurement

#### 4.1.1. Limit

For this product which is designed to be connected to the AC power line, the radio frequency voltage that is conducted back onto the AC power line on any frequency or frequencies within the band 150 kHz to 30 MHz shall not exceed below limits table.

Frequency (MHz)	QP Limit (dBuV)	AV Limit (dBuV)
0.15~0.5	66~56	56~46
0.5~5	56	46
5~30	60	50

#### 4.1.2. Measuring Instruments and Setting

Please refer to section 5 of equipments list in this report. The following table is the setting of the receiver.

Receiver Parameters	Setting
Attenuation	10 dB
Start Frequency	0.15 MHz
Stop Frequency	30 MHz
IF Bandwidth	9 KHz

#### 4.1.3. Test Procedures

1. Configure the EUT according to ANSI C63.10. The EUT or host of EUT has to be placed 0.4 meter far from the conducting wall of the shielding room and at least 80 centimeters from any other grounded conducting surface.
2. Connect EUT or host of EUT to the power mains through a line impedance stabilization network (LISN).
3. All the support units are connected to the other LISNs. The LISN should provide 50uH/50ohms coupling impedance.
4. The frequency range from 150 KHz to 30 MHz was searched.
5. Set the test-receiver system to Peak Detect Function and Specified Bandwidth with Maximum Hold Mode.
6. The measurement has to be done between each power line and ground at the power terminal.

#### 4.1.4. Test Setup Layout

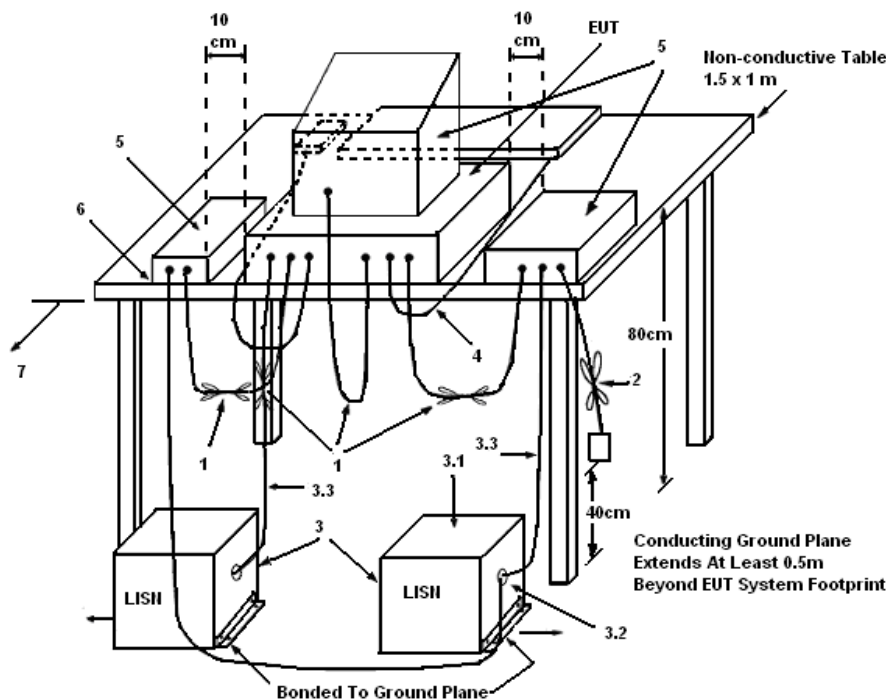

#### LEGEND:

- (1) Interconnecting cables that hang closer than 40 cm to the ground plane shall be folded back and forth in the center forming a bundle 30 to 40 cm long.
- (2) I/O cables that are not connected to a peripheral shall be bundled in the center. The end of the cable may be terminated, if required, using the correct terminating impedance. The overall length shall not exceed 1 m.
- (3) EUT connected to one LISN. Unused LISN measuring port connectors shall be terminated in 50  $\Omega$ . LISN can be placed on top of, or immediately beneath, reference ground plane.
  - (3.1) All other equipment powered from additional LISN(s).
  - (3.2) Multiple outlet strip can be used for multiple power cords of non-EUT equipment.
  - (3.3) LISN at least 80 cm from nearest part of EUT chassis.
- (4) Cables of hand-operated devices, such as keyboards, mice, etc., shall be placed as for normal use.
- (5) Non-EUT components of EUT system being tested.
- (6) Rear of EUT, including peripherals, shall all be aligned and flush with rear of tabletop.
- (7) Rear of tabletop shall be 40 cm removed from a vertical conducting plane that is bonded to the ground plane.

#### 4.1.5. Test Deviation

There is no deviation with the original standard.

#### 4.1.6. EUT Operation during Test

The EUT was placed on the test table and programmed in normal function.



4.1.7. Results of AC Power Line Conducted Emissions Measurement

Temperature	22°C	Humidity	61%
Test Engineer	Sollo Luo	Phase	Line
Configuration	Normal Link		

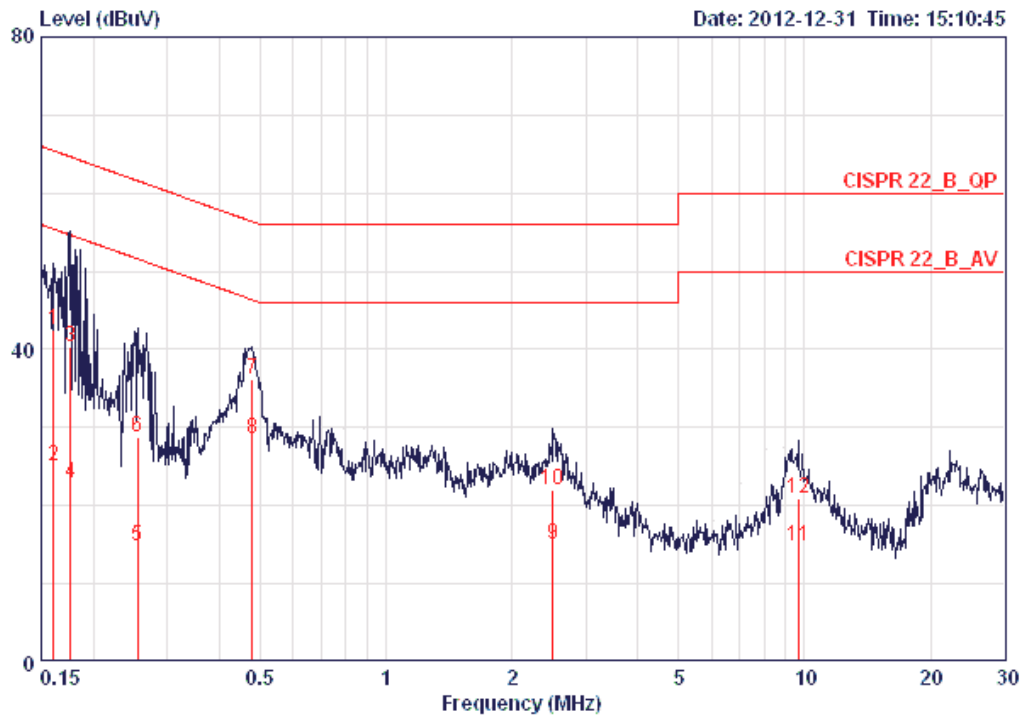

	Freq	Level	Over Limit	Limit Line	Read Level	LISN Factor	Cable Loss	Remark
	MHz	dBuV	dB	dBuV	dBuV	dB	dB	
1	0.16070	42.53	-22.89	65.43	42.19	0.16	0.18	QP
2	0.16070	25.11	-30.31	55.43	24.77	0.16	0.18	AVERAGE
3	0.17584	40.42	-24.26	64.68	40.08	0.15	0.19	QP
4	0.17584	22.87	-31.81	54.68	22.53	0.15	0.19	AVERAGE
5	0.25480	14.78	-36.82	51.60	14.43	0.15	0.20	AVERAGE
6	0.25480	28.85	-32.75	61.60	28.50	0.15	0.20	QP
7	0.47865	36.26	-20.10	56.36	35.91	0.15	0.20	QP
8	0.47865	28.47	-17.89	46.36	28.12	0.15	0.20	AVERAGE
9	2.500	15.01	-30.99	46.00	14.57	0.20	0.24	AVERAGE
10	2.500	22.00	-34.00	56.00	21.56	0.20	0.24	QP
11	9.654	14.87	-35.13	50.00	14.20	0.33	0.33	AVERAGE
12	9.654	20.92	-39.08	60.00	20.25	0.33	0.33	QP

Temperature	22°C	Humidity	61%
Test Engineer	Sollo Luo	Phase	Neutral
Configuration	Normal Link		

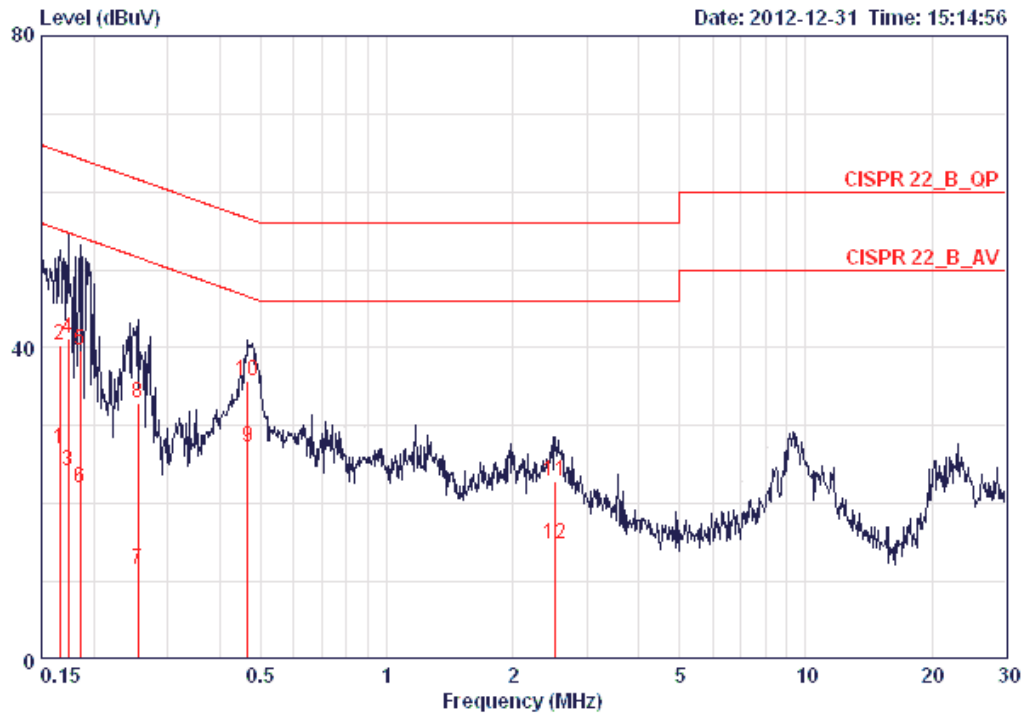

	Freq	Level	Over Limit	Limit Line	Read Level	LISN Factor	Cable Loss	Remark
	MHz	dBuV	dB	dBuV	dBuV	dB	dB	
1	0.16589	26.98	-28.19	55.16	26.71	0.08	0.19	AVERAGE
2	0.16589	40.25	-24.92	65.16	39.98	0.08	0.19	QP
3	0.17399	24.14	-30.63	54.77	23.87	0.08	0.19	AVERAGE
4	0.17399	41.17	-23.60	64.77	40.90	0.08	0.19	QP
5	0.18541	39.68	-24.56	64.24	39.41	0.08	0.19	QP
6	0.18541	22.10	-32.14	54.24	21.83	0.08	0.19	AVERAGE
7	0.25480	11.62	-39.98	51.60	11.34	0.08	0.20	AVERAGE
8	0.25480	33.02	-28.58	61.60	32.74	0.08	0.20	QP
9	0.46614	27.14	-19.44	46.58	26.86	0.08	0.20	AVERAGE
10	0.46614	35.71	-20.87	56.58	35.43	0.08	0.20	QP
11	2.513	22.88	-33.12	56.00	22.52	0.12	0.24	QP
12	2.513	14.77	-31.23	46.00	14.41	0.12	0.24	AVERAGE

Note:

Level = Read Level + LISN Factor + Cable Loss.

## 4.2. Maximum Conducted Output Power Measurement

### 4.2.1. Limit

For systems using digital modulation in the 2400-2483.5MHz, the limit for output power is 30dBm. The limited has to be reduced by the amount in dB that the gain of the antenna exceed 6dBi. In case of point-to-point operation, the limit has to be reduced by 1dB for every 3dB that the directional gain of the antenna exceeds 6dBi.

### 4.2.2. Measuring Instruments and Setting

Please refer to section 5 of equipments list in this report. The following table is the setting of the power meter.

Power Meter Parameter	Setting
Bandwidth	50MHz bandwidth is greater than the EUT emission bandwidth
Detector	Average

### 4.2.3. Test Procedures

1. Test procedures refer KDB558074 v01 r02 section 8.2.3 option 3.
2. This procedure provides an alternative for determining the RMS output power using a broadband RF average power meter with a thermocouple detector.

### 4.2.4. Test Setup Layout

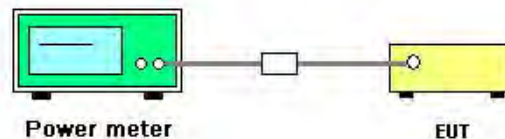

### 4.2.5. Test Deviation

There is no deviation with the original standard.

### 4.2.6. EUT Operation during Test

The EUT was programmed to be in continuously transmitting mode.

#### 4.2.7. Test Result of Maximum Conducted Output Power

Temperature	25°C	Humidity	56%
Test Engineer	Robert Chang	Configurations	IEEE 802.11n
Test Date	Dec. 28, 2012		

##### Configuration IEEE 802.11n MCS0 20MHz / Ant. 1 + Ant. 2 + Ant. 3

Channel	Frequency	Conducted Power (dBm)			Total Conducted Power (dBm)	Max. Limit (dBm)	Result
		Ant. 1	Ant. 2	Ant. 3			
1	2412 MHz	15.33	15.12	16.21	20.35	30.00	Complies
6	2437 MHz	23.07	22.97	22.99	27.78	30.00	Complies
11	2462 MHz	14.34	14.23	15.33	19.43	30.00	Complies

##### Configuration IEEE 802.11n MCS0 40MHz / Ant. 1 + Ant. 2 + Ant. 3

Channel	Frequency	Conducted Power (dBm)			Total Conducted Power (dBm)	Max. Limit (dBm)	Result
		Ant. 1	Ant. 2	Ant. 3			
3	2422 MHz	12.23	12.63	13.28	17.51	30.00	Complies
6	2437 MHz	18.52	18.44	18.95	23.41	30.00	Complies
9	2452 MHz	17.57	17.93	18.17	22.67	30.00	Complies

<b>Temperature</b>	25°C	<b>Humidity</b>	56%
<b>Test Engineer</b>	Robert Chang	<b>Configurations</b>	IEEE 802.11b/g
<b>Test Date</b>	Dec. 28, 2012		

**Configuration IEEE 802.11b / Ant. 1**

Channel	Frequency	Conducted Power (dBm)	Max. Limit (dBm)	Result
1	2412 MHz	23.23	30.00	<b>Complies</b>
6	2437 MHz	26.21	30.00	<b>Complies</b>
11	2462 MHz	22.43	30.00	<b>Complies</b>

**Configuration IEEE 802.11g / Ant. 1**

Channel	Frequency	Conducted Power (dBm)	Max. Limit (dBm)	Result
1	2412 MHz	17.67	30.00	<b>Complies</b>
6	2437 MHz	24.02	30.00	<b>Complies</b>
11	2462 MHz	16.57	30.00	<b>Complies</b>

### 4.3. Power Spectral Density Measurement

#### 4.3.1. Limit

For digitally modulated systems, the power spectral density conducted from the intentional radiator to the antenna shall not be greater than 8 dBm in any 3 kHz band during any time interval of continuous transmission.

#### 4.3.2. Measuring Instruments and Setting

Please refer to section 5 of equipments list in this report. The following table is the setting of the spectrum analyzer.

Spectrum Parameter	Setting
Attenuation	Auto
Span Frequency	Set the span to 1.5 times the DTS channel bandwidth.
RB	100 kHz
VB	300 kHz
Detector	Peak
Trace	Max Hold
Sweep Time	Auto couple

#### 4.3.3. Test Procedures

1. Test procedures refer KDB558074 v01 r02 section 9.1 option 1
2. Spectrum analyzer must be capable of utilizing a number of measurement points in each sweep that is greater than or equal to twice the span/RBW in order to ensure bin-to-bin spacing of  $\leq RBW/2$  so that narrowband signals are not lost between frequency bins.
3. Use this procedure when the maximum conducted output power in the fundamental emission is used to demonstrate compliance. The EUT must be configured to transmit continuously at full power over the measurement duration.
4. Ensure that the number of measurement points in the sweep  $\geq 2 \times \text{span}/\text{RBW}$  (use of a greater number of measurement points than this minimum requirement is recommended).
5. Use the peak marker function to determine the maximum level in any 100 kHz band segment within the fundamental EBW.
6. Scale the observed power level to an equivalent level in 3 kHz by adjusting (reducing) the measured power by a bandwidth correction factor (BWCF) where:  $BWCF = 10\log(3 \text{ kHz}/100 \text{ kHz} = -15.2 \text{ dB})$ .
7. The resulting PSD level must be  $\leq 8 \text{ dBm}$ .
8. When measuring power spectral density with multiple antenna systems, add every result of the values by mathematic formula.

#### 4.3.4. Test Setup Layout

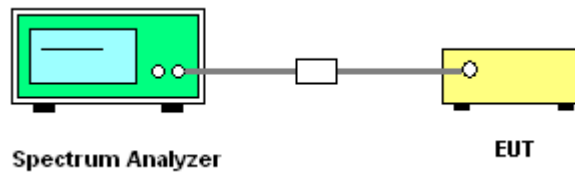

#### 4.3.5. Test Deviation

There is no deviation with the original standard.

#### 4.3.6. EUT Operation during Test

The EUT was programmed to be in continuously transmitting mode.

#### 4.3.7. Test Result of Power Spectral Density

Temperature	25°C	Humidity	56%
Test Engineer	Robert Chang	Configurations	IEEE 802.11n
Test Date	Dec. 28, 2012		

##### Configuration IEEE 802.11n MCS0 20MHz / Ant. 1 + Ant. 2 + Ant. 3

Channel	Frequency	Power Density (dBm/100kHz)			BWCF factor (100KHz to 3KHz)	Power Density (dBm/3kHz)			Single Port Limit (dBm/3kHz)	Result
		Ant. 1	Ant. 2	Ant. 3		Ant. 1	Ant. 2	Ant. 3		
1	2412 MHz	2.74	2.72	3.88	-15.23	-12.49	-12.51	-11.35	3.23	Complies
6	2437 MHz	11.35	11.61	11.51	-15.23	-3.88	-3.62	-3.72	3.23	Complies
11	2462 MHz	1.76	1.52	2.72	-15.23	-13.47	-13.71	-12.51	3.23	Complies

Note: PSD Limit = (8dBm/MHz - (10log(3))) = 3.23dBm/MHz

##### Configuration IEEE 802.11n MCS0 40MHz / Ant. 1 + Ant. 2 + Ant. 3

Channel	Frequency	Power Density (dBm/100kHz)			BWCF factor (100KHz to 3KHz)	Power Density (dBm/3kHz)			Single Port Limit (dBm/3kHz)	Result
		Ant. 1	Ant. 2	Ant. 3		Ant. 1	Ant. 2	Ant. 3		
3	2422 MHz	-2.03	-2.05	-0.94	-15.23	-17.26	-17.28	-16.17	3.23	Complies
6	2437 MHz	4.15	4.52	4.94	-15.23	-11.08	-10.71	-10.29	3.23	Complies
9	2452 MHz	3.06	4.09	3.71	-15.23	-12.17	-11.14	-11.52	3.23	Complies

Note: PSD Limit = (8dBm/MHz - (10log(3))) = 3.23dBm/MHz



<b>Temperature</b>	25°C	<b>Humidity</b>	56%
<b>Test Engineer</b>	Robert Chang	<b>Configurations</b>	IEEE 802.11b/g
<b>Test Date</b>	Dec. 28, 2012		

**Configuration IEEE 802.11b / Ant. 1**

Channel	Frequency	Power Density (dBm/100kHz)	BWCF factor (100KHz to 3KHz)	Power Density (dBm/3kHz)	Max. Limit (dBm/3kHz)	Result
1	2412 MHz	13.90	-15.23	-1.33	8.00	<b>Complies</b>
6	2437 MHz	15.73	-15.23	0.50	8.00	<b>Complies</b>
11	2462 MHz	13.44	-15.23	-1.79	8.00	<b>Complies</b>

**Configuration IEEE 802.11g / Ant. 1**

Channel	Frequency	Power Density (dBm/100kHz)	BWCF factor (100KHz to 3KHz)	Power Density (dBm/3kHz)	Max. Limit (dBm/3kHz)	Result
1	2412 MHz	5.48	-15.23	-9.75	8.00	<b>Complies</b>
6	2437 MHz	12.28	-15.23	-2.95	8.00	<b>Complies</b>
11	2462 MHz	4.50	-15.23	-10.73	8.00	<b>Complies</b>

Note: All the test values were listed in the report.

For plots, only the channel with maximum results was shown.

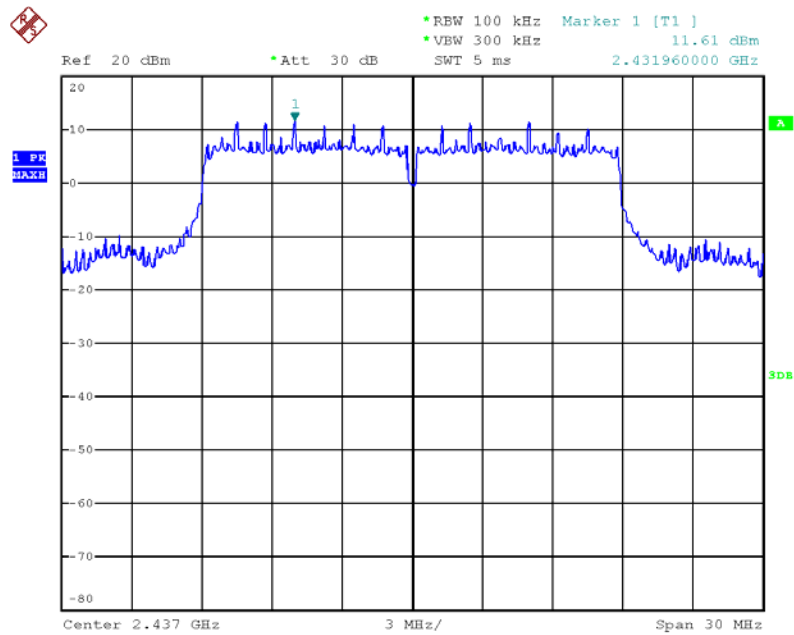
**Power Density Plot on Configuration IEEE 802.11n MCS0 20MHz / 2437 MHz / Ant. 2**

Date: 28.DEC.2012 17:40:44

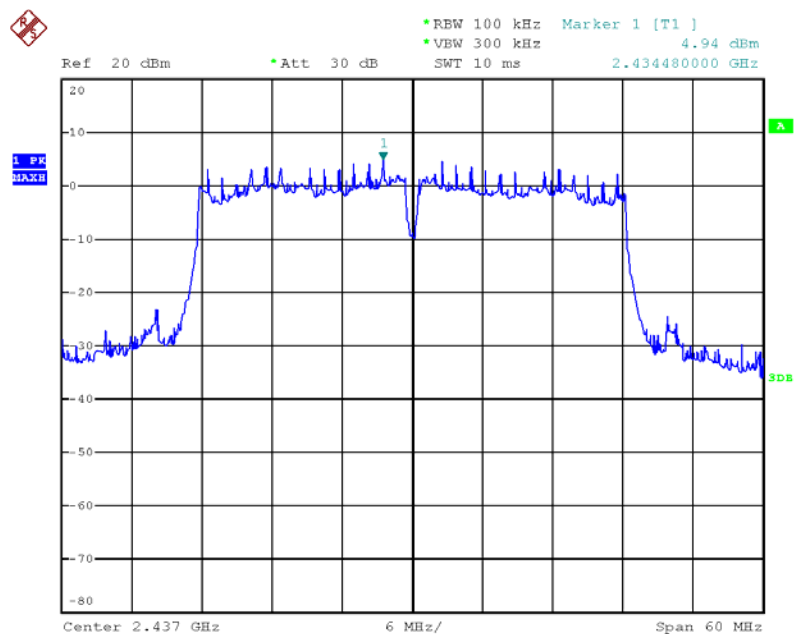
**Power Density Plot on Configuration IEEE 802.11n MCS0 40MHz / 2437 MHz / Ant. 3**

Date: 28.DEC.2012 17:49:05

### Power Density Plot on Configuration IEEE 802.11b / 2437 MHz / Ant. 1

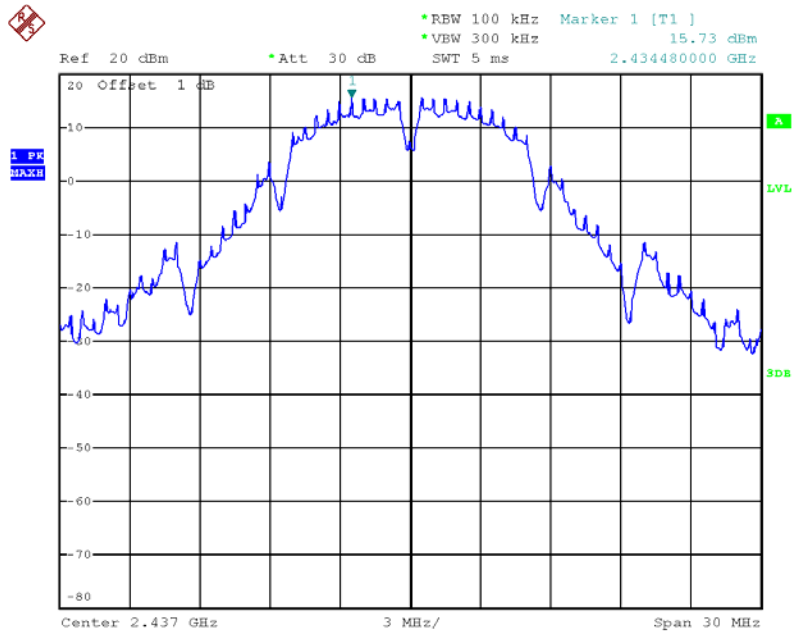

Date: 28.DEC.2012 17:10:28

### Power Density Plot on Configuration IEEE 802.11g / 2437 MHz / Ant. 1

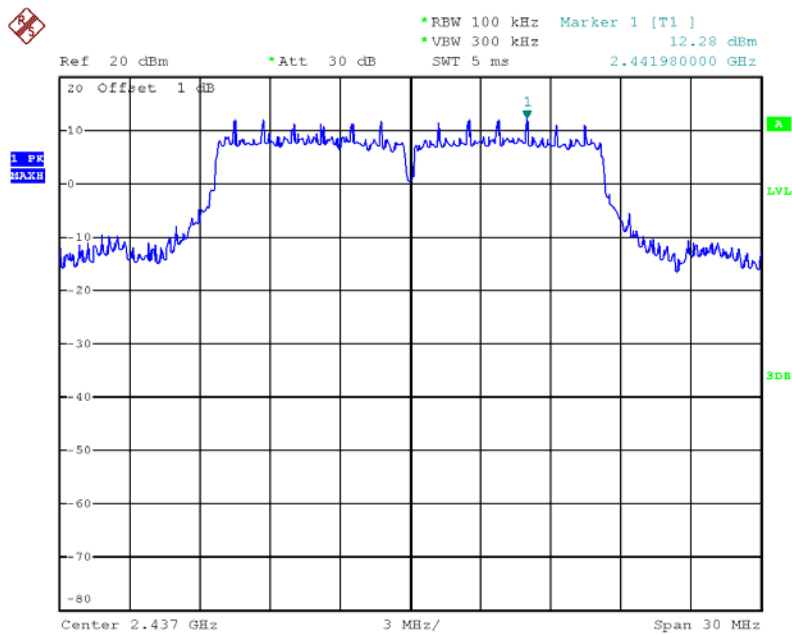

Date: 28.DEC.2012 17:12:45

#### 4.4. 6dB Spectrum Bandwidth Measurement

##### 4.4.1. Limit

For digital modulation systems, the minimum 6 dB bandwidth shall be at least 500 kHz.

##### 4.4.2. Measuring Instruments and Setting

Please refer to section 5 of equipments list in this report. The following table is the setting of the Spectrum Analyzer.

Spectrum Parameters	Setting
Attenuation	Auto
Span Frequency	> 6dB Bandwidth
RB	1-5 % or DTS BW, not exceed 100KHz
VB	$\geq 3 \times \text{RBW}$
Detector	Peak
Trace	Max Hold
Sweep Time	Auto

##### 4.4.3. Test Procedures

1. The transmitter output (antenna port) was connected to the spectrum analyzer in peak hold mode.
2. Test was performed in accordance with KDB 558074 Guidance for Performing Compliance Measurements on Digital Transmission Systems (DTS) Operating Under §15.247 section 5.1.1 EBW Measurement Procedure
3. Multiple antenna system was performed in accordance with KDB 662911 Emissions Testing of Transmitters with Multiple Outputs in the Same Band.
4. Measured the spectrum width with power higher than 6dB below carrier.

##### 4.4.4. Test Setup Layout

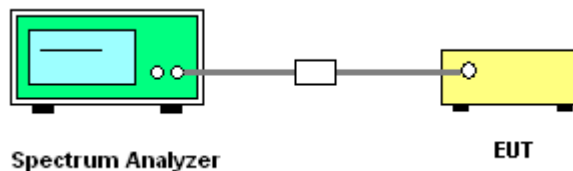

##### 4.4.5. Test Deviation

There is no deviation with the original standard.

##### 4.4.6. EUT Operation during Test

The EUT was programmed to be in continuously transmitting mode.

#### 4.4.7. Test Result of 6dB Spectrum Bandwidth

Temperature	25°C	Humidity	56%
Test Engineer	Robert Chang	Configurations	IEEE 802.11n
Test Date	Dec. 28, 2012		

##### Configuration IEEE 802.11n MCS0 20MHz / Ant. 1 + Ant. 2 + Ant. 3

Channel	Frequency	6dB Bandwidth (MHz)	99% Occupied Bandwidth (MHz)	Min. Limit (kHz)	Test Result
1	2412 MHz	12.00	17.44	500	Complies
6	2437 MHz	11.44	18.24	500	Complies
11	2462 MHz	11.36	17.28	500	Complies

##### Configuration IEEE 802.11n MCS0 40MHz / Ant. 1 + Ant. 2 + Ant. 3

Channel	Frequency	6dB Bandwidth (MHz)	99% Occupied Bandwidth (MHz)	Min. Limit (kHz)	Test Result
3	2422 MHz	30.40	35.20	500	Complies
6	2437 MHz	30.08	35.36	500	Complies
9	2452 MHz	31.52	35.36	500	Complies

<b>Temperature</b>	25°C	<b>Humidity</b>	56%
<b>Test Engineer</b>	Robert Chang	<b>Configurations</b>	IEEE 802.11b/g
<b>Test Date</b>	Dec. 28, 2012		

**Configuration IEEE 802.11b / Ant. 1**

Channel	Frequency	6dB Bandwidth (MHz)	99% Occupied Bandwidth (MHz)	Min. Limit (kHz)	Test Result
1	2412 MHz	8.08	10.24	500	Complies
6	2437 MHz	8.64	12.32	500	Complies
11	2462 MHz	8.08	10.16	500	Complies

**Configuration IEEE 802.11g / Ant. 1**

Channel	Frequency	6dB Bandwidth (MHz)	99% Occupied Bandwidth (MHz)	Min. Limit (kHz)	Test Result
1	2412 MHz	16.48	16.64	500	Complies
6	2437 MHz	16.40	17.44	500	Complies
11	2462 MHz	16.40	16.64	500	Complies

Note: All the test values were listed in the report.

For plots, only the channel with maximum results was shown.

6 dB Bandwidth Plot on Configuration IEEE 802.11n MCS0 20MHz / 2462 MHz / Ant. 1 + Ant. 2 + Ant. 3

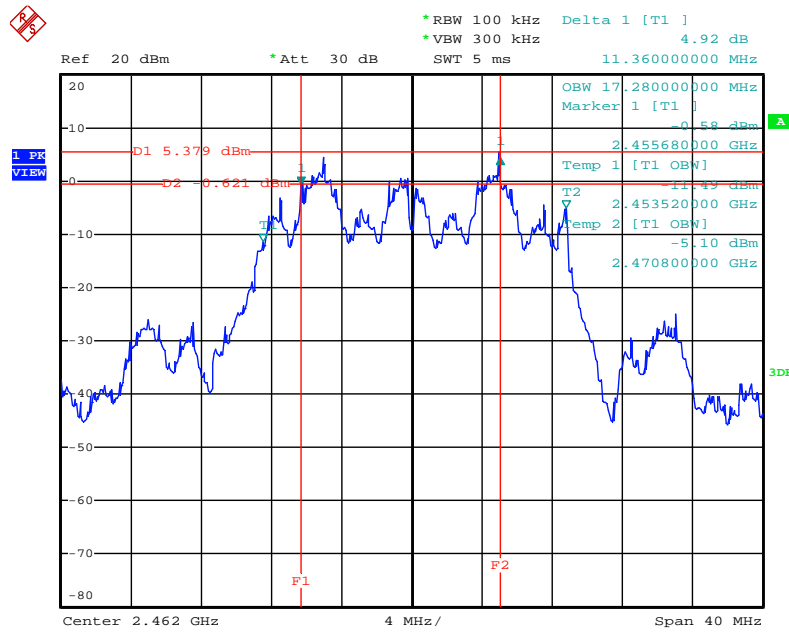

Date: 28.DEC.2012 18:23:05

6 dB Bandwidth Plot on Configuration IEEE 802.11n MCS0 40MHz / 2437 MHz / Ant. 1 + Ant. 2 + Ant. 3

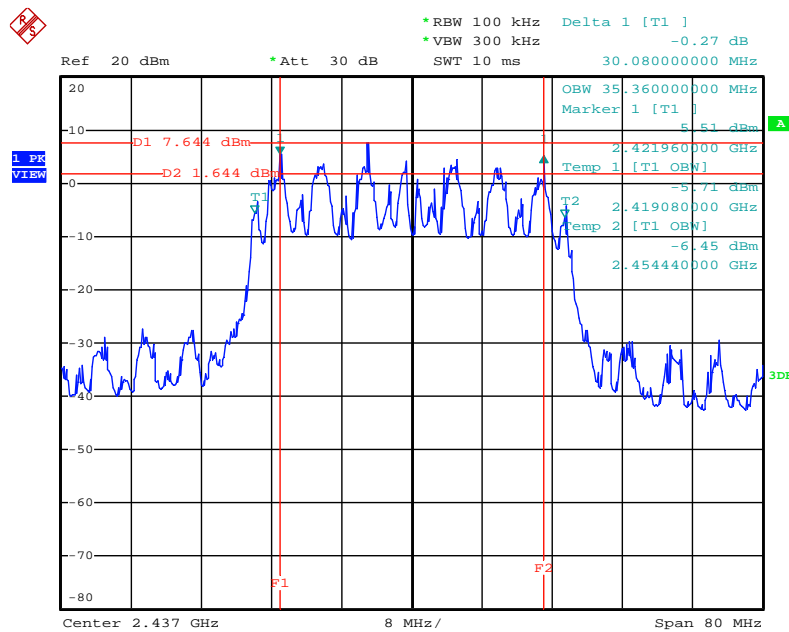

Date: 28.DEC.2012 18:24:52

### 6 dB Bandwidth Plot on Configuration IEEE 802.11b / 2412 MHz / Ant. 1

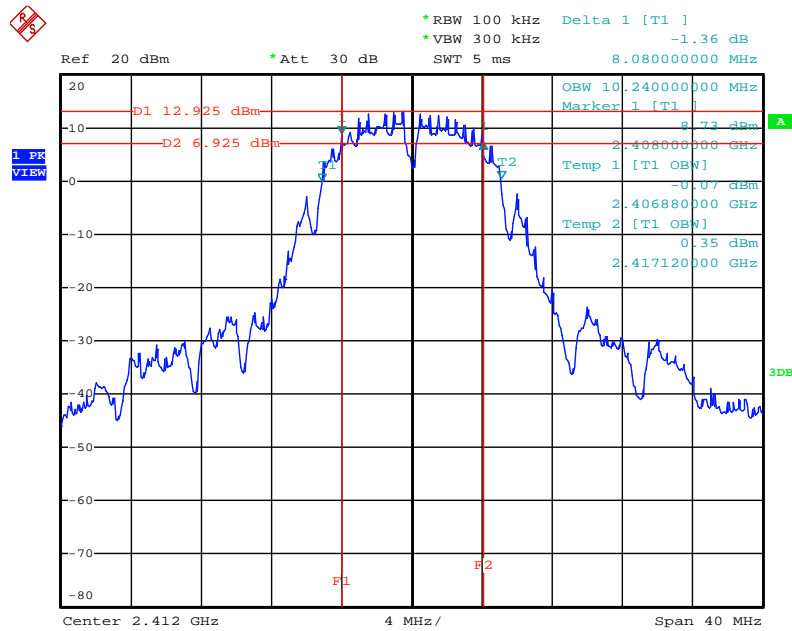

Date: 28.DEC.2012 17:28:26

### 6 dB Bandwidth Plot on Configuration IEEE 802.11g / 2437 MHz / Ant. 1

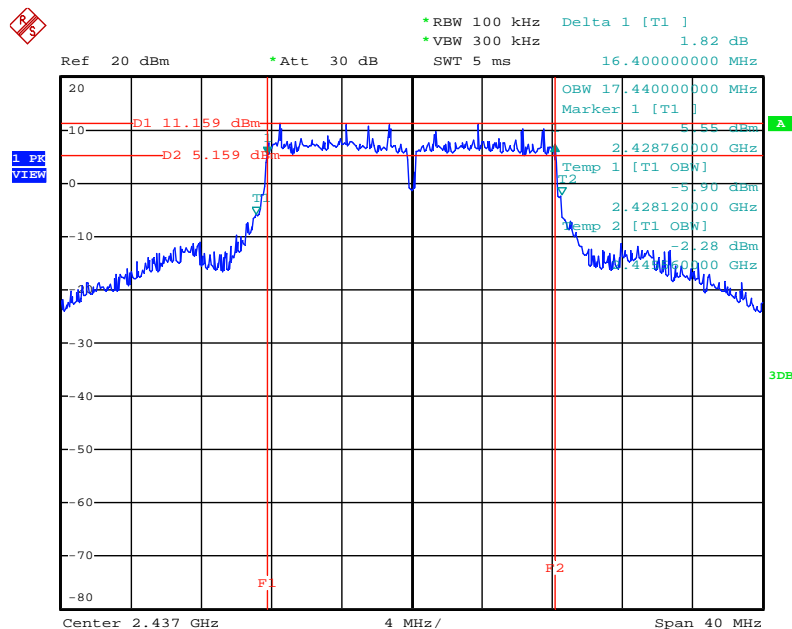

Date: 28.DEC.2012 17:30:54



## 4.5. Radiated Emissions Measurement

### 4.5.1. Limit

30dBc in any 100 kHz bandwidth outside the operating frequency band. In case the emission fall within the restricted band specified on 15.205(a), then the 15.209(a) limit in the table below has to be followed.

Frequencies (MHz)	Field Strength (micorvolts/meter)	Measurement Distance (meters)
0.009~0.490	2400/F(KHz)	300
0.490~1.705	24000/F(KHz)	30
1.705~30.0	30	30
30~88	100	3
88~216	150	3
216~960	200	3
Above 960	500	3

### 4.5.2. Measuring Instruments and Setting

Please refer to section 5 of equipments list in this report. The following table is the setting of spectrum analyzer and receiver.

Spectrum Parameter	Setting
Attenuation	Auto
Start Frequency	1000 MHz
Stop Frequency	10th carrier harmonic
RB / VB (Emission in restricted band)	1 MHz / 3MHz for Peak, 1 MHz / 10Hz for Average
RB / VB (Emission in non-restricted band)	1MHz / 3MHz for peak

Receiver Parameter	Setting
Attenuation	Auto
Start ~ Stop Frequency	9kHz~150kHz / RB 200Hz for QP
Start ~ Stop Frequency	150kHz~30MHz / RB 9kHz for QP
Start ~ Stop Frequency	30MHz~1000MHz / RB 120kHz for QP

#### 4.5.3. Test Procedures

1. Configure the EUT according to ANSI C63.10. The EUT was placed on the top of the turntable 0.8 meter above ground. The phase center of the receiving antenna mounted on the top of a height-variable antenna tower was placed 3 meters far away from the turntable.
2. Power on the EUT and all the supporting units. The turntable was rotated by 360 degrees to determine the position of the highest radiation.
3. The height of the broadband receiving antenna was varied between one meter and four meters above ground to find the maximum emissions field strength of both horizontal and vertical polarization.
4. For each suspected emissions, the antenna tower was scan (from 1 m to 4 m) and then the turntable was rotated (from 0 degree to 360 degrees) to find the maximum reading.
5. Set the test-receiver system to Peak or CISPR quasi-peak Detect Function with specified bandwidth under Maximum Hold Mode.
6. For emissions above 1GHz, use 1MHz VBW and 3MHz RBW for peak reading. Then 1MHz RBW and 10Hz VBW for average reading in spectrum analyzer.
7. When the radiated emissions limits are expressed in terms of the average value of the emissions, and pulsed operation is employed, the measurement field strength shall be determined by averaging over one complete pulse train, including blanking intervals, as long as the pulse train does not exceed 0.1 seconds. As an alternative (provided the transmitter operates for longer than 0.1 seconds) or in cases where the pulse train exceeds 0.1 seconds, the measured field strength shall be determined from the average absolute voltage during a 0.1 second interval during which the field strength is at its maximum value.
8. If the emissions level of the EUT in peak mode was 3 dB lower than the average limit specified, then testing will be stopped and peak values of EUT will be reported, otherwise, the emissions which do not have 3 dB margin will be repeated one by one using the quasi-peak method for below 1GHz.
9. For testing above 1GHz, the emissions level of the EUT in peak mode was lower than average limit (that means the emissions level in peak mode also complies with the limit in average mode), then testing will be stopped and peak values of EUT will be reported, otherwise, the emissions will be measured in average mode again and reported.
10. In case the emission is lower than 30MHz, loop antenna has to be used for measurement and the recorded data should be QP measured by receiver. High – Low scan is not required in this case.

#### 4.5.4. Test Setup Layout

For Radiated Emissions below 1GHz

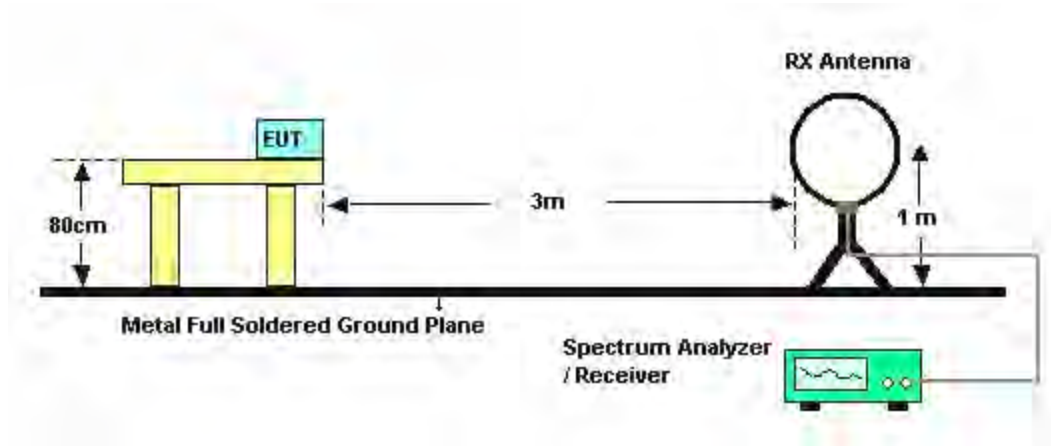

For Radiated Emissions above 1GHz

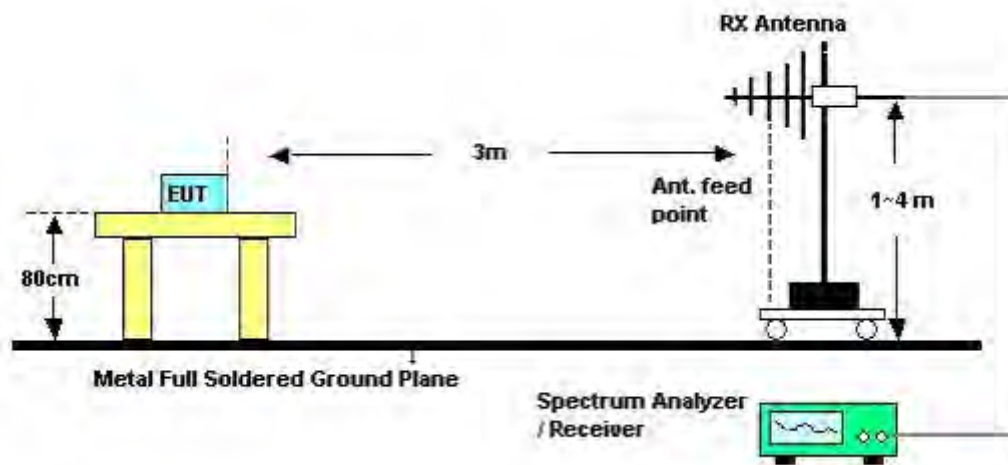

#### 4.5.5. Test Deviation

There is no deviation with the original standard.

#### 4.5.6. EUT Operation during Test

The EUT was programmed to be in continuously transmitting mode.

#### 4.5.7. Results of Radiated Emissions (9kHz~30MHz)

Temperature	26°C	Humidity	60%
Test Engineer	Magic Lai	Configurations	Normal Link
Test Date	Dec. 20, 2012		

Freq. (MHz)	Level (dBuV)	Over Limit (dB)	Limit Line (dBuV)	Remark
-	-	-	-	See Note

**Note:**

The amplitude of spurious emissions which are attenuated by more than 20 dB below the permissible value has no need to be reported.

Distance extrapolation factor =  $40 \log(\text{specific distance} / \text{test distance})$  (dB);

Limit line = specific limits (dBuV) + distance extrapolation factor.

4.5.8. Results of Radiated Emissions (30MHz~1GHz)

Temperature	26°C	Humidity	60%
Test Engineer	Magic Lai	Configurations	Normal Link

Horizontal

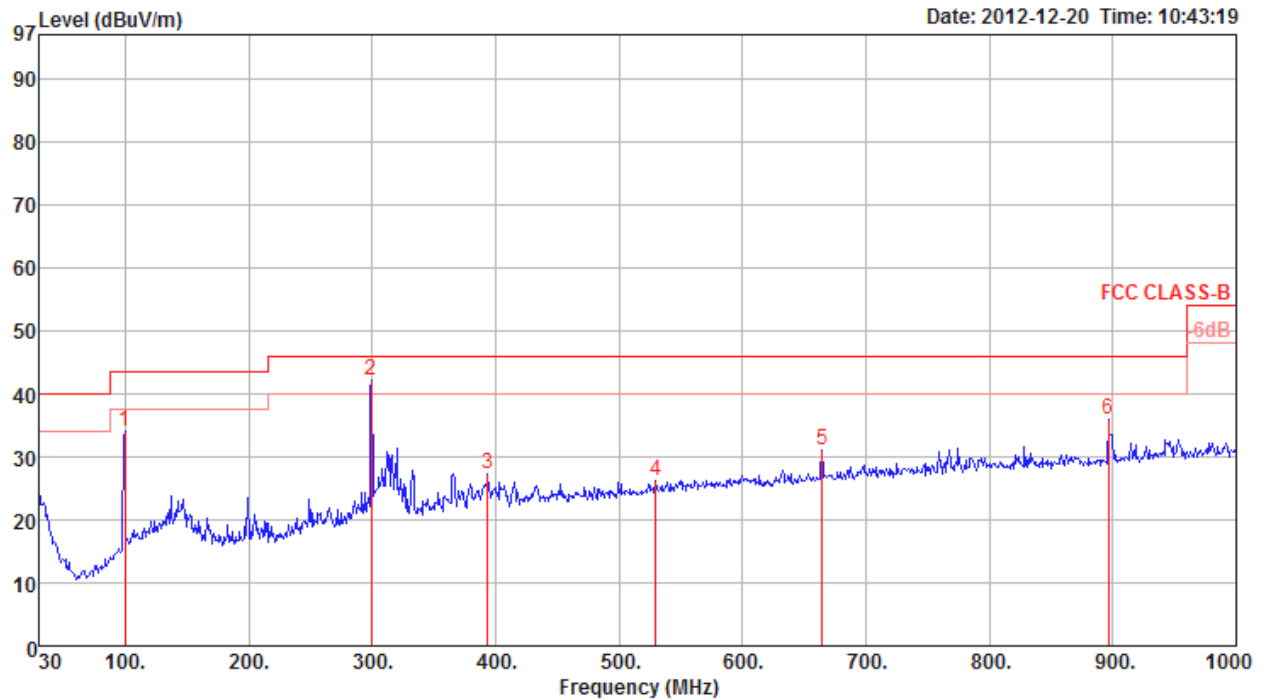

	Freq	Level	Limit	Over	Read	Cable	Preamp	Antenna	Remark	T/Pos	A/Pos	Pol/Phase
	MHz	dBuV/m	dBuV/m	dB	dBuV	dB	dB	dB/m		deg	cm	
1	99.84	34.16	43.50	-9.34	49.08	1.50	27.82	11.40	Peak	0	400	HORIZONTAL
2	299.66	42.23	46.00	-3.77	52.75	2.51	26.83	13.80	Peak	0	400	HORIZONTAL
3	393.75	27.18	46.00	-18.82	35.27	2.96	27.41	16.36	Peak	0	400	HORIZONTAL
4	529.55	26.12	46.00	-19.88	32.16	3.47	27.90	18.39	Peak	0	400	HORIZONTAL
5	664.38	31.16	46.00	-14.84	34.88	3.98	27.42	19.72	Peak	0	400	HORIZONTAL
6	896.21	35.81	46.00	-10.19	36.59	4.58	26.84	21.48	Peak	0	400	HORIZONTAL

**Vertical**

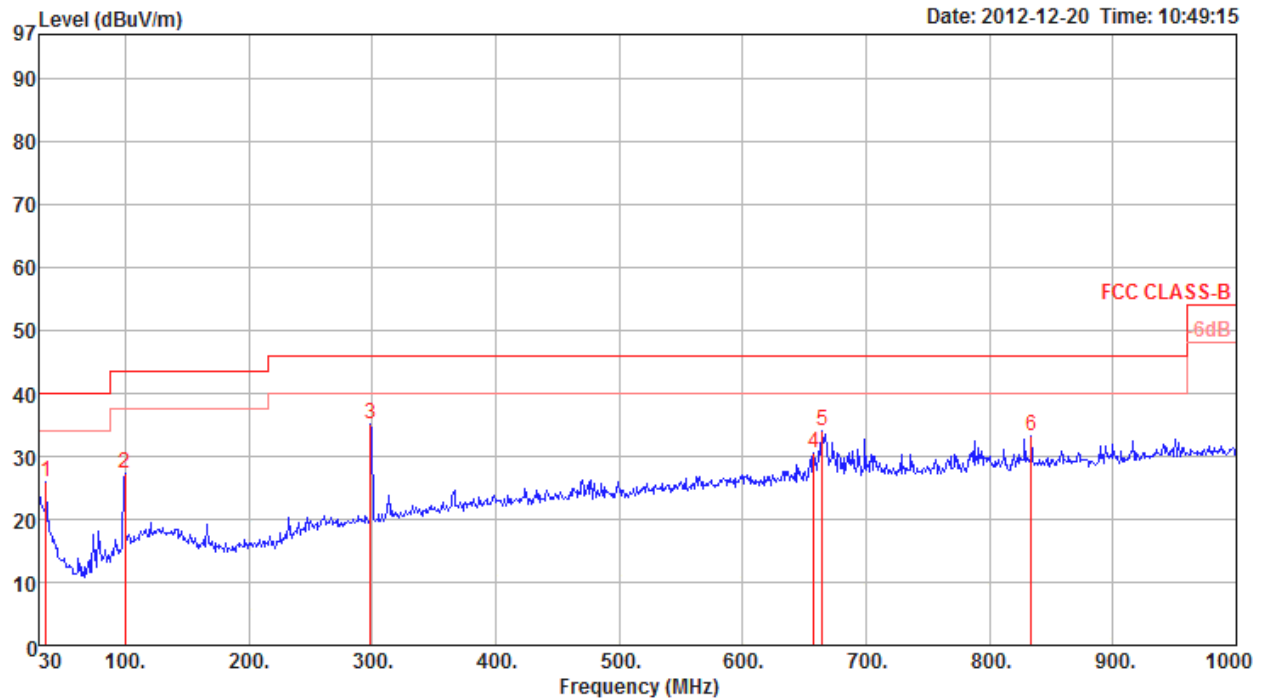

	Freq	Level	Limit	Over	Read	Cable	Preamp	Antenna	Remark	T/Pos	A/Pos	Pol/Phase
	MHz	dBuV/m	dBuV/m	dB	dBuV	dB	dB	dB/m		deg	cm	
1	35.82	26.01	40.00	-13.99	36.82	0.93	28.00	16.26	Peak	0	100	VERTICAL
2	99.84	27.18	43.50	-16.32	42.10	1.50	27.82	11.40	Peak	0	100	VERTICAL
3	298.69	35.15	46.00	-10.85	45.67	2.51	26.83	13.80	Peak	0	100	VERTICAL
4	657.59	30.60	46.00	-15.40	34.49	3.94	27.49	19.66	Peak	0	100	VERTICAL
5	664.38	33.92	46.00	-12.08	37.64	3.98	27.42	19.72	Peak	0	100	VERTICAL
6	834.13	33.17	46.00	-12.83	34.59	4.41	26.90	21.07	Peak	0	100	VERTICAL

**Note:**

The amplitude of spurious emissions which are attenuated by more than 20 dB below the permissible value has no need to be reported.

Emission level (dBuV/m) = 20 log Emission level (uV/m).

Corrected Reading: Antenna Factor + Cable Loss + Read Level - Preamp Factor = Level.

**4.5.9. Results for Radiated Emissions (1GHz~10<sup>th</sup> Harmonic)**

<b>Temperature</b>	26°C	<b>Humidity</b>	60%
<b>Test Engineer</b>	Magic Lai	<b>Configurations</b>	IEEE 802.11n MCS0 20MHz Ch 1 / Ant. 1 + Ant. 2 + Ant. 3
<b>Test Date</b>	Dec. 13, 2012		

**Horizontal**

	Freq	Level	Limit Line	Over Limit	Read Level	CableAntenna Loss	Antenna Factor	Preamp Factor	Remark	A/Pos	T/Pos	Pol/Phase
	MHz	dBuV/m	dBuV/m	dB	dBuV	dB	dB/m	dB		cm	deg	
1	4823.80	45.87	74.00	-28.13	41.41	6.27	33.39	35.20	Peak	100	277	HORIZONTAL
2	4824.00	33.44	54.00	-20.56	28.98	6.27	33.39	35.20	Average	100	277	HORIZONTAL

**Vertical**

	Freq	Level	Limit Line	Over Limit	Read Level	CableAntenna Loss	Antenna Factor	Preamp Factor	Remark	A/Pos	T/Pos	Pol/Phase
	MHz	dBuV/m	dBuV/m	dB	dBuV	dB	dB/m	dB		cm	deg	
1	4824.40	52.30	74.00	-21.70	47.84	6.27	33.39	35.20	Peak	184	271	VERTICAL
2	4824.48	40.04	54.00	-13.96	35.58	6.27	33.39	35.20	Average	184	271	VERTICAL

<b>Temperature</b>	26°C	<b>Humidity</b>	60%
<b>Test Engineer</b>	Magic Lai	<b>Configurations</b>	IEEE 802.11n MCS0 20MHz Ch 6 / Ant. 1 + Ant. 2 + Ant. 3
<b>Test Date</b>	Dec. 13, 2012		

#### Horizontal

	Freq	Level	Limit Line	Over Limit	Read Level	Cable Loss	Antenna Factor	Preamp Factor	Remark	A/Pos	T/Pos	Pol/Phase
	MHz	dBuV/m	dBuV/m	dB	dBuV	dB	dB/m	dB		cm	deg	
1	4870.89	33.45	54.00	-20.55	31.99	3.33	33.16	35.03	Average	100	339	HORIZONTAL
2	4878.39	43.95	74.00	-30.05	42.49	3.33	33.16	35.03	Peak	100	339	HORIZONTAL
3	7307.30	35.35	54.00	-18.65	30.77	4.06	35.92	35.40	Average	100	74	HORIZONTAL
4	7314.43	46.46	74.00	-27.54	41.84	4.06	35.96	35.40	Peak	100	74	HORIZONTAL

#### Vertical

	Freq	Level	Limit Line	Over Limit	Read Level	Cable Loss	Antenna Factor	Preamp Factor	Remark	A/Pos	T/Pos	Pol/Phase
	MHz	dBuV/m	dBuV/m	dB	dBuV	dB	dB/m	dB		cm	deg	
1	4874.17	39.52	54.00	-14.48	38.06	3.33	33.16	35.03	Average	111	234	VERTICAL
2	4874.80	52.80	74.00	-21.20	51.34	3.33	33.16	35.03	Peak	111	234	VERTICAL
3	7306.96	59.29	74.00	-14.71	54.71	4.06	35.92	35.40	Peak	130	248	VERTICAL
4	7307.68	45.54	54.00	-8.46	40.92	4.06	35.96	35.40	Average	130	248	VERTICAL



<b>Temperature</b>	26°C	<b>Humidity</b>	60%
<b>Test Engineer</b>	Magic Lai	<b>Configurations</b>	IEEE 802.11n MCS0 20MHz Ch11 / Ant. 1 + Ant. 2 + Ant. 3
<b>Test Date</b>	Dec. 13, 2012		

### Horizontal

	Freq	Level	Limit Line	Over Limit	Read Level	CableAntenna Loss	Antenna Factor	Preamp Factor	Remark	A/Pos	T/Pos	Pol/Phase
	MHz	dBuV/m	dBuV/m	dB	dBuV	dB	dB/m	dB		cm	deg	
1	4914.24	32.85	54.00	-21.15	28.16	6.35	33.54	35.20	Average	100	47	HORIZONTAL
2	4914.36	43.87	74.00	-30.13	39.18	6.35	33.54	35.20	Peak	100	47	HORIZONTAL
3	7391.64	48.58	74.00	-25.42	39.79	7.64	36.61	35.46	Peak	100	126	HORIZONTAL
4	7393.00	35.47	54.00	-18.53	26.65	7.64	36.64	35.46	Average	100	126	HORIZONTAL

### Vertical

	Freq	Level	Limit Line	Over Limit	Read Level	CableAntenna Loss	Antenna Factor	Preamp Factor	Remark	A/Pos	T/Pos	Pol/Phase
	MHz	dBuV/m	dBuV/m	dB	dBuV	dB	dB/m	dB		cm	deg	
1	4920.88	36.53	54.00	-17.47	31.84	6.35	33.54	35.20	Average	180	264	VERTICAL
2	4925.36	49.12	74.00	-24.88	44.39	6.35	33.58	35.20	Peak	180	264	VERTICAL
3	7379.64	48.05	74.00	-25.95	39.28	7.61	36.61	35.45	Peak	100	175	VERTICAL
4	7392.40	35.48	54.00	-18.52	26.69	7.64	36.61	35.46	Average	100	175	VERTICAL

<b>Temperature</b>	26°C	<b>Humidity</b>	60%
<b>Test Engineer</b>	Magic Lai	<b>Configurations</b>	IEEE 802.11n MCS0 40MHz Ch 3 / Ant. 1 + Ant. 2 + Ant. 3
<b>Test Date</b>	Dec. 13, 2012		

### Horizontal

	Freq	Level	Limit	Over	Read	CableAntenna	Preamp	Remark	A/Pos	T/Pos	Pol/Phase
	MHz	dBuV/m	dBuV/m	dB	dBuV	dB	dB/m	dB	cm	deg	
1	4844.24	31.65	54.00	-22.35	27.14	6.29	33.42	35.20 Average	100	313	HORIZONTAL
2	4849.80	44.46	74.00	-29.54	39.95	6.29	33.42	35.20 Peak	100	313	HORIZONTAL

### Vertical

	Freq	Level	Limit	Over	Read	CableAntenna	Preamp	Remark	A/Pos	T/Pos	Pol/Phase
	MHz	dBuV/m	dBuV/m	dB	dBuV	dB	dB/m	dB	cm	deg	
1	4834.88	31.94	54.00	-22.06	27.48	6.27	33.39	35.20 Average	100	229	VERTICAL
2	4851.20	44.52	74.00	-29.48	40.01	6.29	33.42	35.20 Peak	100	229	VERTICAL

<b>Temperature</b>	26°C	<b>Humidity</b>	60%
<b>Test Engineer</b>	Magic Lai	<b>Configurations</b>	IEEE 802.11n MCS0 40MHz Ch 6 / Ant. 1 + Ant. 2 + Ant. 3
<b>Test Date</b>	Dec. 13, 2012		

#### Horizontal

	Freq	Level	Limit	Over	Read	CableAntenna	Preamp	Remark	A/Pos	T/Pos	Pol/Phase
	MHz	dBuV/m	dBuV/m	dB	dBuV	dB	dB/m	dB	cm	deg	
1	4881.92	43.92	74.00	-30.08	39.33	6.31	33.48	35.20 Peak	100	255	HORIZONTAL
2	4883.96	31.49	54.00	-22.51	26.90	6.31	33.48	35.20 Average	100	255	HORIZONTAL
3	7303.68	34.58	54.00	-19.42	26.01	7.51	36.48	35.42 Average	100	146	HORIZONTAL
4	7316.24	47.19	74.00	-26.81	38.57	7.54	36.51	35.43 Peak	100	146	HORIZONTAL

#### Vertical

	Freq	Level	Limit	Over	Read	CableAntenna	Preamp	Remark	A/Pos	T/Pos	Pol/Phase
	MHz	dBuV/m	dBuV/m	dB	dBuV	dB	dB/m	dB	cm	deg	
1	4870.52	52.29	74.00	-21.71	47.73	6.31	33.45	35.20 Peak	181	272	VERTICAL
2	4878.92	37.36	54.00	-16.64	32.77	6.31	33.48	35.20 Average	181	272	VERTICAL
3	7301.60	34.74	54.00	-19.26	26.17	7.51	36.48	35.42 Average	100	240	VERTICAL
4	7309.36	47.73	74.00	-26.27	39.14	7.51	36.51	35.43 Peak	100	240	VERTICAL

<b>Temperature</b>	26°C	<b>Humidity</b>	60%
<b>Test Engineer</b>	Magic Lai	<b>Configurations</b>	IEEE 802.11n MCS0 40MHz Ch 9 / Ant. 1 + Ant. 2 + Ant. 3
<b>Test Date</b>	Dec. 13, 2012		

### Horizontal

	Freq	Level	Limit	Over	Read	CableAntenna	Preamp	Remark	A/Pos	T/Pos	Pol/Phase
	MHz	dBuV/m	dBuV/m	dB	dBuV	dB	dB/m	dB	cm	deg	
1	4904.04	32.45	54.00	-21.55	27.81	6.33	33.51	35.20 Average	40	326	HORIZONTAL
2	4904.56	45.07	74.00	-28.93	40.43	6.33	33.51	35.20 Peak	100	326	HORIZONTAL
3	7362.12	34.98	54.00	-19.02	26.27	7.57	36.59	35.45 Average	100	152	HORIZONTAL
4	7364.00	46.87	74.00	-27.13	38.12	7.61	36.59	35.45 Peak	100	152	HORIZONTAL

### Vertical

	Freq	Level	Limit	Over	Read	CableAntenna	Preamp	Remark	A/Pos	T/Pos	Pol/Phase
	MHz	dBuV/m	dBuV/m	dB	dBuV	dB	dB/m	dB	cm	deg	
1	4904.08	37.67	54.00	-16.33	33.03	6.33	33.51	35.20 Average	178	263	VERTICAL
2	4906.08	50.32	74.00	-23.68	45.65	6.33	33.54	35.20 Peak	178	263	VERTICAL
3	7348.40	35.03	54.00	-18.97	26.34	7.57	36.56	35.44 Average	100	248	VERTICAL
4	7350.52	47.35	74.00	-26.65	38.66	7.57	36.56	35.44 Peak	100	248	VERTICAL

<b>Temperature</b>	26°C	<b>Humidity</b>	60%
<b>Test Engineer</b>	Magic Lai	<b>Configurations</b>	IEEE 802.11b CH 1 / Ant. 1
<b>Test Date</b>	Dec. 13, 2012		

### Horizontal

	Freq	Level	Limit Line	Over Limit	Read Level	CableAntenna Loss	Antenna Factor	Preamp Factor	Remark	A/Pos	T/Pos	Pol/Phase
	MHz	dBuV/m	dBuV/m	dB	dBuV	dB	dB/m	dB		cm	deg	
1	4823.92	53.86	74.00	-20.14	52.52	3.31	33.06	35.03	Peak	153	314	HORIZONTAL
2	4823.97	51.62	54.00	-2.38	50.28	3.31	33.06	35.03	Average	153	314	HORIZONTAL

### Vertical

	Freq	Level	Limit Line	Over Limit	Read Level	CableAntenna Loss	Antenna Factor	Preamp Factor	Remark	A/Pos	T/Pos	Pol/Phase
	MHz	dBuV/m	dBuV/m	dB	dBuV	dB	dB/m	dB		cm	deg	
1	4823.97	53.54	54.00	-0.46	52.20	3.31	33.06	35.03	Average	155	231	VERTICAL
2	4823.97	55.96	74.00	-18.04	54.62	3.31	33.06	35.03	Peak	155	231	VERTICAL

<b>Temperature</b>	26°C	<b>Humidity</b>	60%
<b>Test Engineer</b>	Magic Lai	<b>Configurations</b>	IEEE 802.11b CH 6 / Ant. 1
<b>Test Date</b>	Dec. 13, 2012		

### Horizontal

	Freq	Level	Limit Line	Over Limit	Read Level	Cable Loss	Antenna Factor	Preamp Factor	Remark	A/Pos	T/Pos	Pol/Phase
	MHz	dBuV/m	dBuV/m	dB	dBuV	dB	dB/m	dB		cm	deg	
1	4873.99	51.80	54.00	-2.20	50.34	3.33	33.16	35.03	Average	180	289	HORIZONTAL
2	4874.00	54.60	74.00	-19.40	53.14	3.33	33.16	35.03	Peak	180	289	HORIZONTAL
3	7309.57	46.37	74.00	-27.63	41.75	4.06	35.96	35.40	Peak	100	178	HORIZONTAL
4	7310.19	33.46	54.00	-20.54	28.84	4.06	35.96	35.40	Average	100	178	HORIZONTAL

### Vertical

	Freq	Level	Limit Line	Over Limit	Read Level	Cable Loss	Antenna Factor	Preamp Factor	Remark	A/Pos	T/Pos	Pol/Phase
	MHz	dBuV/m	dBuV/m	dB	dBuV	dB	dB/m	dB		cm	deg	
1	4873.95	55.74	74.00	-18.26	54.28	3.33	33.16	35.03	Peak	112	252	VERTICAL
2	4873.96	53.32	54.00	-0.68	51.86	3.33	33.16	35.03	Average	112	252	VERTICAL
3	7309.49	46.60	74.00	-27.40	41.98	4.06	35.96	35.40	Peak	100	21	VERTICAL
4	7309.81	37.21	54.00	-16.79	32.59	4.06	35.96	35.40	Average	100	21	VERTICAL

<b>Temperature</b>	26°C	<b>Humidity</b>	60%
<b>Test Engineer</b>	Magic Lai	<b>Configurations</b>	IEEE 802.11b CH 11 / Ant. 1
<b>Test Date</b>	Dec. 13, 2012		

### Horizontal

	Freq	Level	Limit Line	Over Limit	Read Level	CableAntenna Loss	Antenna Factor	Preamp Factor	Remark	A/Pos	T/Pos	Pol/Phase
	MHz	dBuV/m	dBuV/m	dB	dBuV	dB	dB/m	dB		cm	deg	
1	4923.98	47.32	54.00	-6.68	45.72	3.35	33.26	35.01	Average	208	23	HORIZONTAL
2	4924.04	51.00	74.00	-23.00	49.40	3.35	33.26	35.01	Peak	208	23	HORIZONTAL
3	7383.72	45.98	74.00	-28.02	41.23	4.06	36.09	35.40	Peak	100	227	HORIZONTAL
4	7383.77	32.95	54.00	-21.05	28.20	4.06	36.09	35.40	Average	100	227	HORIZONTAL

### Vertical

	Freq	Level	Limit Line	Over Limit	Read Level	CableAntenna Loss	Antenna Factor	Preamp Factor	Remark	A/Pos	T/Pos	Pol/Phase
	MHz	dBuV/m	dBuV/m	dB	dBuV	dB	dB/m	dB		cm	deg	
1	4923.97	51.70	54.00	-2.30	50.10	3.35	33.26	35.01	Average	108	239	VERTICAL
2	4923.98	54.41	74.00	-19.59	52.81	3.35	33.26	35.01	Peak	108	239	VERTICAL
3	7384.78	34.90	54.00	-19.10	30.15	4.06	36.09	35.40	Average	100	94	VERTICAL
4	7388.37	46.01	74.00	-27.99	41.26	4.06	36.09	35.40	Peak	100	94	VERTICAL

<b>Temperature</b>	26°C	<b>Humidity</b>	60%
<b>Test Engineer</b>	Magic Lai	<b>Configurations</b>	IEEE 802.11g CH 1 / Ant. 1
<b>Test Date</b>	Dec. 13, 2012		

### Horizontal

	Freq	Level	Limit Line	Over Limit	Read Level	CableAntenna Loss	Antenna Factor	Preamp Factor	Remark	A/Pos	T/Pos	Pol/Phase
	MHz	dBuV/m	dBuV/m	dB	dBuV	dB	dB/m	dB		cm	deg	
1	4818.92	44.51	74.00	-29.49	40.08	6.27	33.36	35.20	Peak	100	245	HORIZONTAL
2	4825.16	32.06	54.00	-21.94	27.60	6.27	33.39	35.20	Average	100	245	HORIZONTAL

### Vertical

	Freq	Level	Limit Line	Over Limit	Read Level	CableAntenna Loss	Antenna Factor	Preamp Factor	Remark	A/Pos	T/Pos	Pol/Phase
	MHz	dBuV/m	dBuV/m	dB	dBuV	dB	dB/m	dB		cm	deg	
1	4823.80	36.90	54.00	-17.10	32.44	6.27	33.39	35.20	Average	168	271	VERTICAL
2	4826.44	49.22	74.00	-24.78	44.76	6.27	33.39	35.20	Peak	168	271	VERTICAL



<b>Temperature</b>	26°C	<b>Humidity</b>	60%
<b>Test Engineer</b>	Magic Lai	<b>Configurations</b>	IEEE 802.11g CH 6 / Ant. 1
<b>Test Date</b>	Dec. 13, 2012		

### Horizontal

	Freq	Level	Limit Line	Over Limit	Read Level	CableAntenna Loss	Antenna Factor	Preamp Factor	Remark	A/Pos	T/Pos	Pol/Phase
	MHz	dBuV/m	dBuV/m	dB	dBuV	dB	dB/m	dB		cm	deg	
1	4869.16	45.35	74.00	-28.65	40.79	6.31	33.45	35.20	Peak	100	307	HORIZONTAL
2	4874.92	33.25	54.00	-20.75	28.66	6.31	33.48	35.20	Average	100	307	HORIZONTAL
3	7301.44	34.87	54.00	-19.13	26.30	7.51	36.48	35.42	Average	100	256	HORIZONTAL
4	7305.36	47.34	74.00	-26.66	38.77	7.51	36.48	35.42	Peak	100	256	HORIZONTAL

### Vertical

	Freq	Level	Limit Line	Over Limit	Read Level	CableAntenna Loss	Antenna Factor	Preamp Factor	Remark	A/Pos	T/Pos	Pol/Phase
	MHz	dBuV/m	dBuV/m	dB	dBuV	dB	dB/m	dB		cm	deg	
1	4871.36	39.41	54.00	-14.59	34.82	6.31	33.48	35.20	Average	184	270	VERTICAL
2	4874.68	52.75	74.00	-21.25	48.16	6.31	33.48	35.20	Peak	184	270	VERTICAL
3	7309.92	34.97	54.00	-19.03	26.38	7.51	36.51	35.43	Average	100	251	VERTICAL
4	7315.88	47.04	74.00	-26.96	38.42	7.54	36.51	35.43	Peak	100	251	VERTICAL

<b>Temperature</b>	26°C	<b>Humidity</b>	60%
<b>Test Engineer</b>	Magic Lai	<b>Configurations</b>	IEEE 802.11g CH 11 / Ant. 1
<b>Test Date</b>	Dec. 13, 2012		

### Horizontal

	Freq	Level	Limit Line	Over Limit	Read Level	Cable Loss	Antenna Factor	Preamp Factor	Remark	A/Pos	T/Pos	Pol/Phase
	MHz	dBuV/m	dBuV/m	dB	dBuV	dB	dB/m	dB		cm	deg	
1	4917.32	31.69	54.00	-22.31	27.00	6.35	33.54	35.20	Average	100	187	HORIZONTAL
2	4919.16	43.78	74.00	-30.22	39.09	6.35	33.54	35.20	Peak	100	187	HORIZONTAL
3	7384.52	47.93	74.00	-26.07	39.17	7.61	36.61	35.46	Peak	100	328	HORIZONTAL
4	7395.20	35.50	54.00	-18.50	26.68	7.64	36.64	35.46	Average	100	328	HORIZONTAL

### Vertical

	Freq	Level	Limit Line	Over Limit	Read Level	Cable Loss	Antenna Factor	Preamp Factor	Remark	A/Pos	T/Pos	Pol/Phase
	MHz	dBuV/m	dBuV/m	dB	dBuV	dB	dB/m	dB		cm	deg	
1	4914.56	44.79	74.00	-29.21	40.10	6.35	33.54	35.20	Peak	100	272	VERTICAL
2	4917.96	32.81	54.00	-21.19	28.12	6.35	33.54	35.20	Average	100	272	VERTICAL
3	7377.16	47.64	74.00	-26.36	38.87	7.61	36.61	35.45	Peak	100	275	VERTICAL
4	7384.36	35.34	54.00	-18.66	26.58	7.61	36.61	35.46	Average	100	275	VERTICAL

### Note:

The amplitude of spurious emissions that are attenuated by more than 20dB below the permissible value has no need to be reported.

Emission level (dBuV/m) = 20 log Emission level (uV/m).

Corrected Reading: Antenna Factor + Cable Loss + Read Level - Preamp Factor = Level.

## 4.6. Band Edge Emissions Measurement

### 4.6.1. Limit

30dBc in any 100 kHz bandwidth outside the operating frequency band. In case the emission fall within the restricted band specified on 15.205(a), then the 15.209(a) limit in the table below has to be followed.

Frequencies (MHz)	Field Strength (micovolts/meter)	Measurement Distance (meters)
0.009~0.490	2400/F(KHz)	300
0.490~1.705	24000/F(KHz)	30
1.705~30.0	30	30
30~88	100	3
88~216	150	3
216~960	200	3
Above 960	500	3

### 4.6.2. Measuring Instruments and Setting

Please refer to section 5 of equipments list in this report. The following table is the setting of the spectrum analyzer.

Spectrum Parameter	Setting
Attenuation	Auto
Span Frequency	100 MHz
RB / VB (Emission in restricted band)	1 MHz / 3MHz for Peak, 1 MHz / 10Hz for Average
RB / VB (Emission in non-restricted band)	100 KHz / 300 KHz for Peak

### 4.6.3. Test Procedures

The test procedure is the same as section 4.5.3, only the frequency range investigated is limited to 100MHz around bandedges.

### 4.6.4. Test Setup Layout

This test setup layout is the same as that shown in section 4.5.4.

### 4.6.5. Test Deviation

There is no deviation with the original standard.

### 4.6.6. EUT Operation during Test

The EUT was programmed to be in continuously transmitting mode.

#### 4.6.7. Test Result of Band Edge and Fundamental Emissions

Temperature	26°C	Humidity	60%
Test Engineer	Magic Lai	Configurations	IEEE 802.11n MCS0 20MHz Ch 1, 6, 11 / Ant. 1 + Ant. 2 + Ant. 3
Test Date	Dec. 15, 2012		

##### Channel 1

	Freq	Level	Limit	Over	Read	CableAntenna	Preamp		A/Pos	T/Pos	
	MHz	dBuV/m	dBuV/m	dB	dBuV	Loss	Factor	Factor	cm	deg	Pol/Phase
1	2388.80	53.96	54.00	-0.04	21.57	4.34	28.05	0.00	232	57	HORIZONTAL
2	2389.00	70.22	74.00	-3.78	37.83	4.34	28.05	0.00	232	57	HORIZONTAL
3	2403.80	100.43	54.00			4.34	28.09	0.00	232	57	HORIZONTAL
4	2406.80	111.28	74.00			4.34	28.09	0.00	232	57	HORIZONTAL

Item 3, 4 are the fundamental frequency at 2412 MHz.

##### Channel 6

	Freq	Level	Limit	Over	Read	CableAntenna	Preamp		A/Pos	T/Pos	
	MHz	dBuV/m	dBuV/m	dB	dBuV	Loss	Factor	Factor	cm	deg	Pol/Phase
1	2387.12	59.76	74.00	-14.24	29.38	2.21	28.17	0.00	151	121	HORIZONTAL
2	2387.44	46.14	54.00	-7.86	15.76	2.21	28.17	0.00	151	121	HORIZONTAL
3	2431.87	104.20	54.00			2.23	28.25	0.00	151	121	HORIZONTAL
4	2431.87	114.47	74.00			2.23	28.25	0.00	151	121	HORIZONTAL
5	2483.50	46.61	54.00	-7.39	15.97	2.26	28.38	0.00	151	121	HORIZONTAL
6	2487.35	61.28	74.00	-12.72	30.60	2.26	28.42	0.00	151	121	HORIZONTAL

Item 3, 4 are the fundamental frequency at 2437MHz.

##### Channel 11

	Freq	Level	Limit	Over	Read	CableAntenna	Preamp		A/Pos	T/Pos	
	MHz	dBuV/m	dBuV/m	dB	dBuV	Loss	Factor	Factor	cm	deg	Pol/Phase
1	2458.20	112.40	74.00			4.38	28.22	0.00	227	54	HORIZONTAL
2	2458.60	101.61	54.00			4.38	28.22	0.00	227	54	HORIZONTAL
3	2483.50	53.90	54.00	-0.10	21.24	4.40	28.26	0.00	227	54	HORIZONTAL
4	2484.10	69.30	74.00	-4.70	36.64	4.40	28.26	0.00	227	54	HORIZONTAL

Item 1, 2 are the fundamental frequency at 2462 MHz.

<b>Temperature</b>	26°C	<b>Humidity</b>	60%
<b>Test Engineer</b>	Magic Lai	<b>Configurations</b>	IEEE 802.11n MCS0 40MHz Ch 3, 6, 9 / Ant. 1 + Ant. 2 + Ant. 3
<b>Test Date</b>	Dec. 15, 2012		

**Channel 3**

	Freq	Level	Limit Line	Over Limit	Read Level	CableAntenna Loss	Antenna Factor	Preamp Factor	Remark	A/Pos	T/Pos	Pol/Phase
	MHz	dBuV/m	dBuV/m	dB	dBuV	dB	dB/m	dB		cm	deg	
1	2388.72	67.86	74.00	-6.14	37.48	2.21	28.17	0.00	Peak	192	140	HORIZONTAL
2	2389.36	53.62	54.00	-0.38	23.24	2.21	28.17	0.00	Average	192	140	HORIZONTAL
3	2423.92	92.83	54.00			2.23	28.25	0.00	Average	192	140	HORIZONTAL
4	2424.56	103.30	74.00			2.23	28.25	0.00	Peak	192	140	HORIZONTAL

Item 3, 4 are the fundamental frequency at 2422 MHz.

**Channel 6**

	Freq	Level	Limit Line	Over Limit	Read Level	CableAntenna Loss	Antenna Factor	Preamp Factor	Remark	A/Pos	T/Pos	Pol/Phase
	MHz	dBuV/m	dBuV/m	dB	dBuV	dB	dB/m	dB		cm	deg	
1	2388.72	51.89	54.00	-2.11	21.51	2.21	28.17	0.00	Average	221	126	HORIZONTAL
2	2389.36	67.57	74.00	-6.43	37.19	2.21	28.17	0.00	Peak	221	126	HORIZONTAL
3	2433.80	109.70	74.00			2.23	28.25	0.00	Peak	221	126	HORIZONTAL
4	2434.12	98.12	54.00			2.23	28.29	0.00	Average	221	126	HORIZONTAL
5	2484.14	53.86	54.00	-0.14	23.22	2.26	28.38	0.00	Average	221	126	HORIZONTAL
6	2484.46	70.41	74.00	-3.59	39.77	2.26	28.38	0.00	Peak	221	126	HORIZONTAL

Item 3, 4 are the fundamental frequency at 2437MHz.

**Channel 9**

	Freq	Level	Limit Line	Over Limit	Read Level	CableAntenna Loss	Antenna Factor	Preamp Factor	Remark	A/Pos	T/Pos	Pol/Phase
	MHz	dBuV/m	dBuV/m	dB	dBuV	dB	dB/m	dB		cm	deg	
1	2453.28	96.88	54.00			2.24	28.33	0.00	Average	228	100	HORIZONTAL
2	2453.28	107.70	74.00			2.24	28.33	0.00	Peak	228	100	HORIZONTAL
3	2483.50	72.62	74.00	-1.38	41.98	2.26	28.38	0.00	Peak	228	100	HORIZONTAL
4	2488.31	53.67	54.00	-0.33	22.99	2.26	28.42	0.00	Average	228	100	HORIZONTAL

Item 1, 2 are the fundamental frequency at 2452 MHz.

<b>Temperature</b>	26°C	<b>Humidity</b>	60%
<b>Test Engineer</b>	Magic Lai	<b>Configurations</b>	IEEE 802.11b CH 1, 6, 11 / Ant. 1
<b>Test Date</b>	Dec. 15, 2012		

**Channel 1**

	Freq	Level	Limit Line	Over Limit	Read Level	Cable Loss	Antenna Factor	Preamp Factor	Remark	A/Pos	T/Pos	Pol/Phase
	MHz	dBuV/m	dBuV/m	dB	dBuV	dB	dB/m	dB		cm	deg	
1	2387.20	53.78	54.00	-0.22	21.41	4.32	28.05	0.00	Average	200	82	HORIZONTAL
2	2387.80	62.31	74.00	-11.69	29.92	4.34	28.05	0.00	Peak	200	82	HORIZONTAL
3	2411.00	111.49	74.00			4.34	28.09	0.00	Peak	200	82	HORIZONTAL
4	2411.20	107.63	54.00			4.34	28.09	0.00	Average	200	82	HORIZONTAL

Item 3, 4 are the fundamental frequency at 2412 MHz.

**Channel 6**

	Freq	Level	Limit Line	Over Limit	Read Level	Cable Loss	Antenna Factor	Preamp Factor	Remark	A/Pos	T/Pos	Pol/Phase
	MHz	dBuV/m	dBuV/m	dB	dBuV	dB	dB/m	dB		cm	deg	
1	2376.40	60.90	74.00	-13.10	28.57	4.32	28.01	0.00	Peak	194	84	HORIZONTAL
2	2377.60	48.66	54.00	-5.34	16.33	4.32	28.01	0.00	Average	194	84	HORIZONTAL
3	2436.20	110.84	54.00			4.36	28.18	0.00	Average	194	84	HORIZONTAL
4	2438.20	114.80	74.00			4.38	28.18	0.00	Peak	194	84	HORIZONTAL
5	2496.00	60.81	74.00	-13.19	28.09	4.42	28.30	0.00	Peak	194	84	HORIZONTAL
6	2497.60	49.42	54.00	-4.58	16.70	4.42	28.30	0.00	Average	194	84	HORIZONTAL

Item 3, 4 are the fundamental frequency at 2437MHz.

**Channel 11**

	Freq	Level	Limit Line	Over Limit	Read Level	Cable Loss	Antenna Factor	Preamp Factor	Remark	A/Pos	T/Pos	Pol/Phase
	MHz	dBuV/m	dBuV/m	dB	dBuV	dB	dB/m	dB		cm	deg	
1	2461.20	109.03	54.00			4.38	28.22	0.00	Average	200	86	HORIZONTAL
2	2461.20	112.92	74.00			4.38	28.22	0.00	Peak	200	86	HORIZONTAL
3	2483.50	53.17	54.00	-0.83	20.51	4.40	28.26	0.00	Average	40	86	HORIZONTAL
4	2483.50	61.47	74.00	-12.53	28.81	4.40	28.26	0.00	Peak	200	86	HORIZONTAL

Item 1, 2 are the fundamental frequency at 2462 MHz.

<b>Temperature</b>	26°C	<b>Humidity</b>	60%
<b>Test Engineer</b>	Magic Lai	<b>Configurations</b>	IEEE 802.11g CH 1, 6, 11 / Ant. 1
<b>Test Date</b>	Dec. 15, 2012		

**Channel 1**

	Freq	Level	Limit Line	Over Limit	Read Level	CableAntenna Loss	Antenna Factor	Preamp Factor	Remark	A/Pos	T/Pos	Pol/Phase
	MHz	dBuV/m	dBuV/m	dB	dBuV	dB	dB/m	dB		cm	deg	
1	2389.80	69.33	74.00	-4.67	36.94	4.34	28.05	0.00	Peak	205	80	HORIZONTAL
2	2390.00	53.91	54.00	-0.09	21.52	4.34	28.05	0.00	Average	205	80	HORIZONTAL
3	2404.40	97.39	54.00			4.34	28.09	0.00	Average	205	80	HORIZONTAL
4	2407.80	107.78	74.00			4.34	28.09	0.00	Peak	205	80	HORIZONTAL

Item 3, 4 are the fundamental frequency at 2412 MHz.

**Channel 6**

	Freq	Level	Limit Line	Over Limit	Read Level	CableAntenna Loss	Antenna Factor	Preamp Factor	Remark	A/Pos	T/Pos	Pol/Phase
	MHz	dBuV/m	dBuV/m	dB	dBuV	dB	dB/m	dB		cm	deg	
1	2389.04	59.89	74.00	-14.11	29.51	2.21	28.17	0.00	Peak	190	355	HORIZONTAL
2	2390.00	47.11	54.00	-6.89	16.72	2.22	28.17	0.00	Average	190	355	HORIZONTAL
3	2432.51	111.66	74.00			2.23	28.25	0.00	Peak	190	355	HORIZONTAL
4	2433.15	100.71	54.00			2.23	28.25	0.00	Average	190	355	HORIZONTAL
5	2483.50	46.68	54.00	-7.32	16.04	2.26	28.38	0.00	Average	190	355	HORIZONTAL
6	2484.14	61.11	74.00	-12.89	30.47	2.26	28.38	0.00	Peak	190	355	HORIZONTAL

Item 3, 4 are the fundamental frequency at 2437 MHz.

**Channel 11**

	Freq	Level	Limit Line	Over Limit	Read Level	CableAntenna Loss	Antenna Factor	Preamp Factor	Remark	A/Pos	T/Pos	Pol/Phase
	MHz	dBuV/m	dBuV/m	dB	dBuV	dB	dB/m	dB		cm	deg	
1	2466.40	98.00	54.00			4.40	28.22	0.00	Average	190	83	HORIZONTAL
2	2466.40	108.73	74.00			4.40	28.22	0.00	Peak	190	83	HORIZONTAL
3	2483.50	53.69	54.00	-0.31	21.03	4.40	28.26	0.00	Average	190	83	HORIZONTAL
4	2483.70	66.25	74.00	-7.75	33.59	4.40	28.26	0.00	Peak	190	83	HORIZONTAL

Item 1, 2 are the fundamental frequency at 2462 MHz.

Note:

Emission level (dBuV/m) = 20 log Emission level (uV/m).

Corrected Reading: Antenna Factor + Cable Loss + Read Level - Preamp Factor = Level.

**For Emission not in Restricted Band**

**Plot on Configuration IEEE 802.11n MCS0 20MHz / Reference Level**

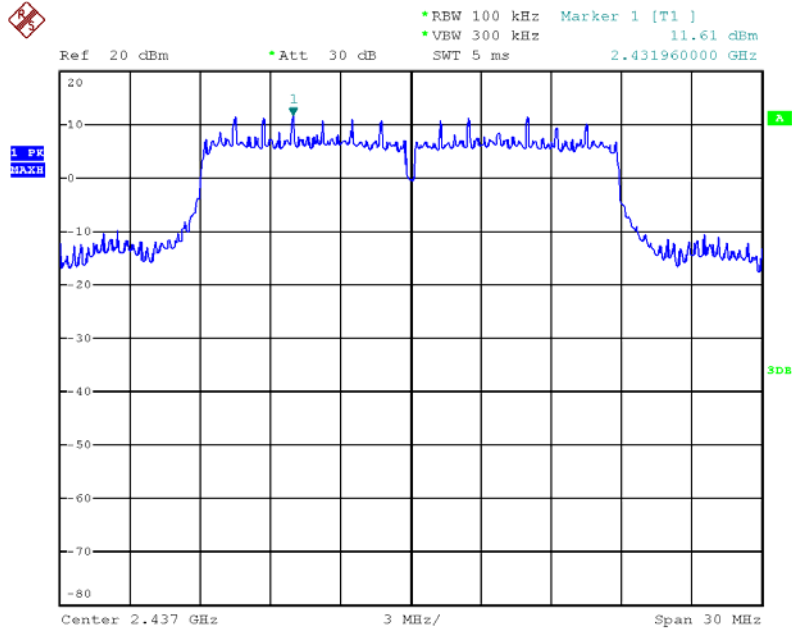

Date: 28.DEC.2012 17:40:44

**Plot on Configuration IEEE 802.11n MCS0 20MHz / CH 1 (down 30dBc)**

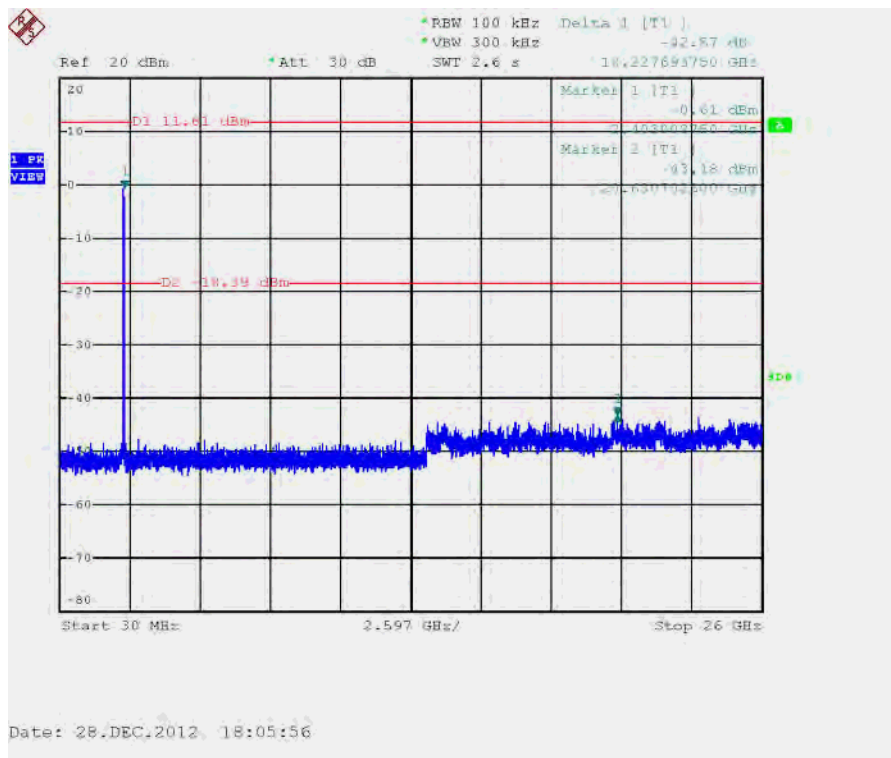



Plot on Configuration IEEE 802.11n MCS0 20MHz / CH 6 (down 30dBc)

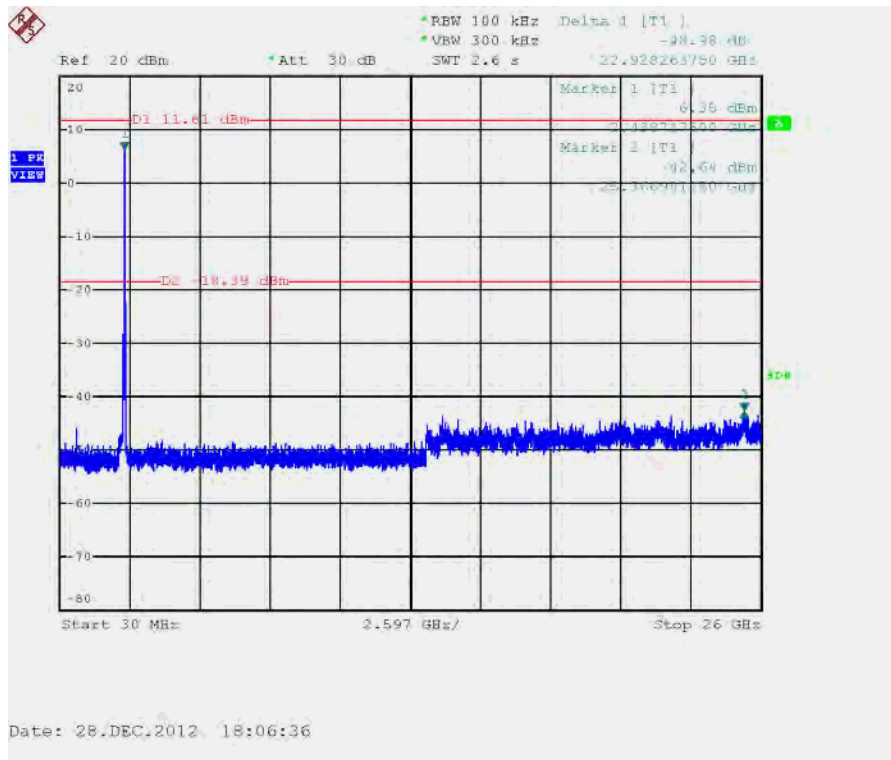

Plot on Configuration IEEE 802.11n MCS0 20MHz / CH 11 (down 30dBc)

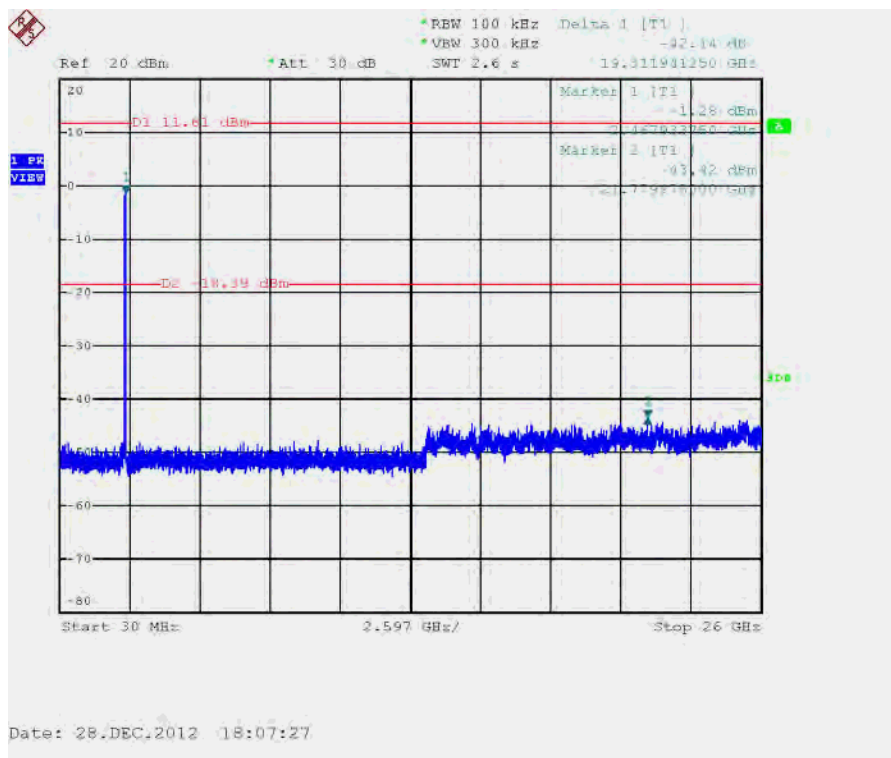

Plot on Configuration IEEE 802.11n MCS0 40MHz / Reference Level

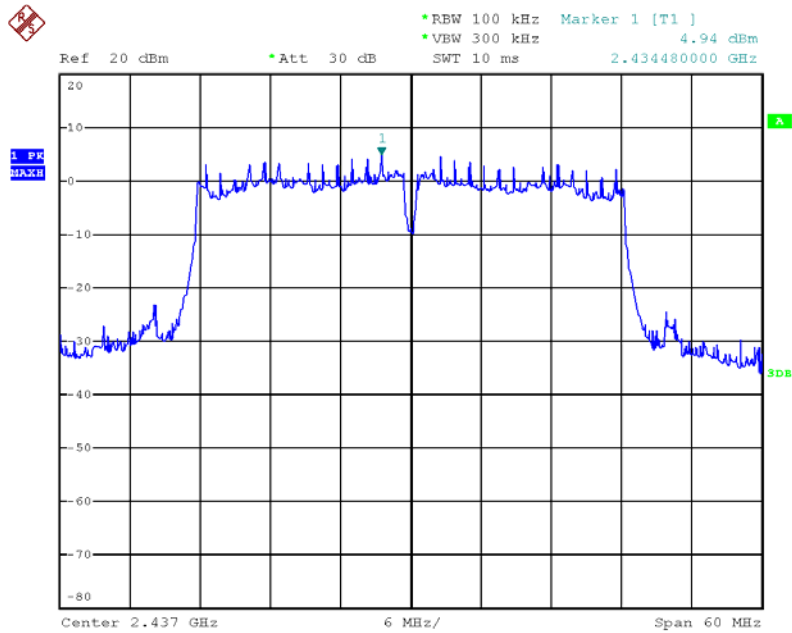

Date: 28.DEC.2012 17:49:05

Plot on Configuration IEEE 802.11n MCS0 40MHz / CH 3 (down 30dBc)

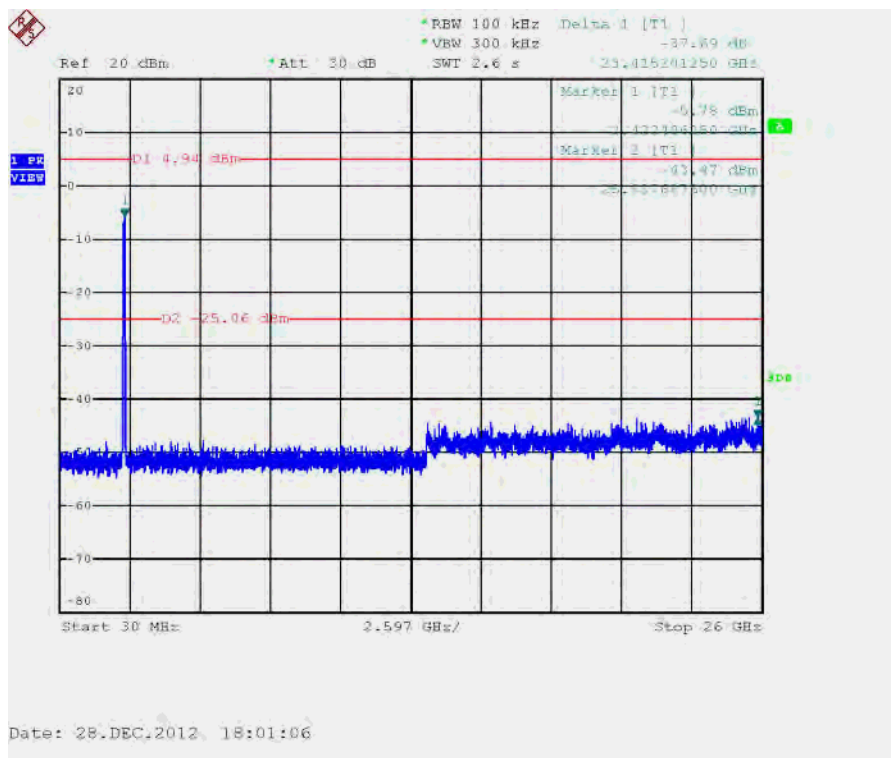

Date: 28.DEC.2012 18:01:06

Plot on Configuration IEEE 802.11n MCS0 40MHz / CH 6 (down 30dBc)

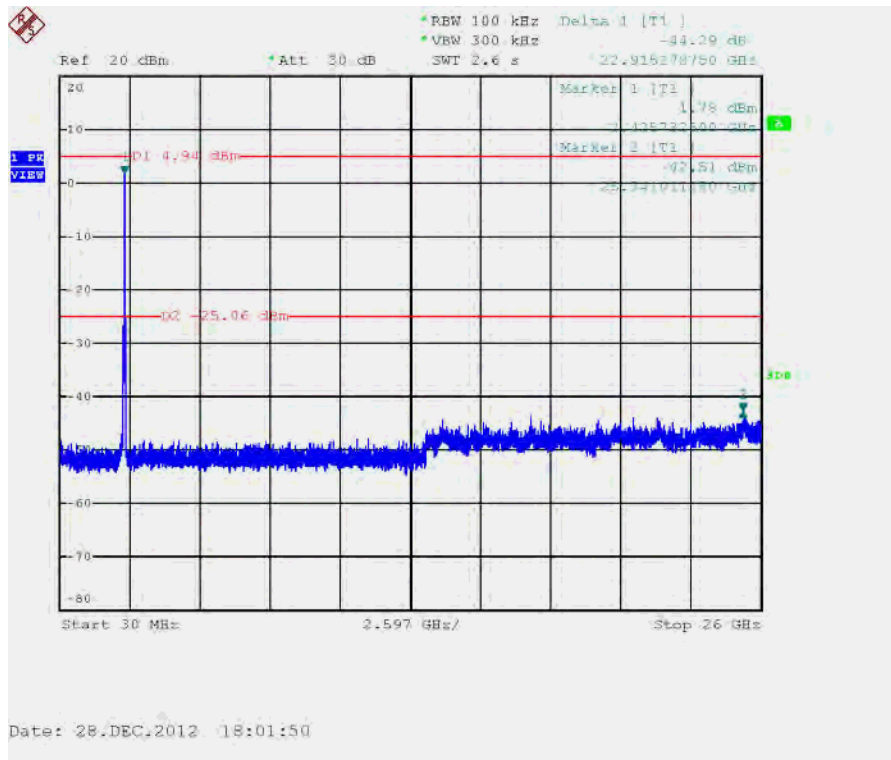

Plot on Configuration IEEE 802.11n MCS0 40MHz / CH 9 (down 30dBc)

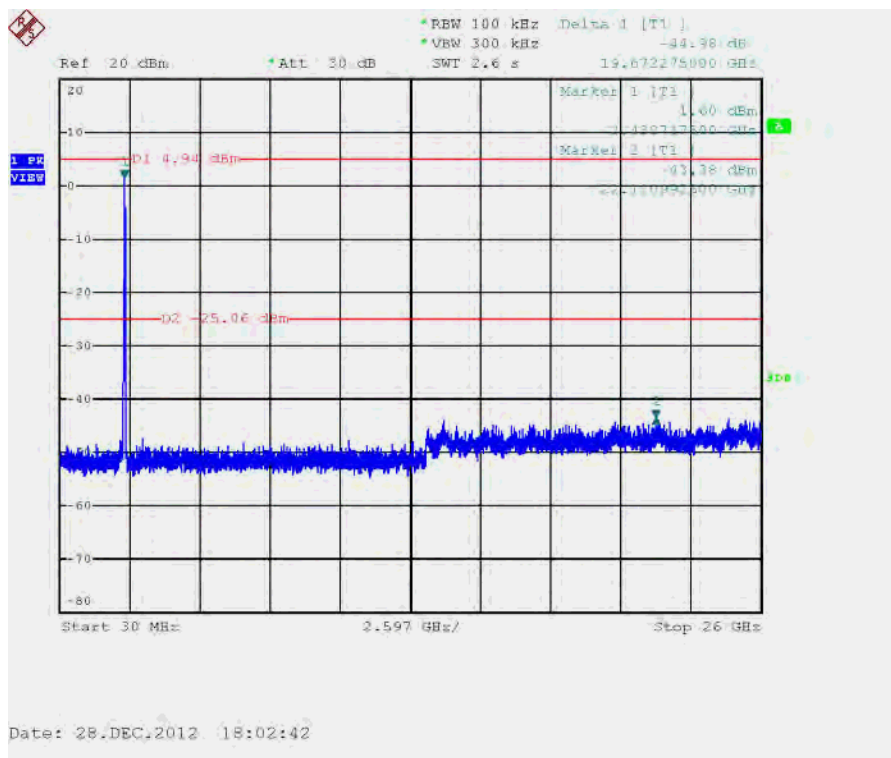

Plot on Configuration IEEE 802.11b / Reference Level

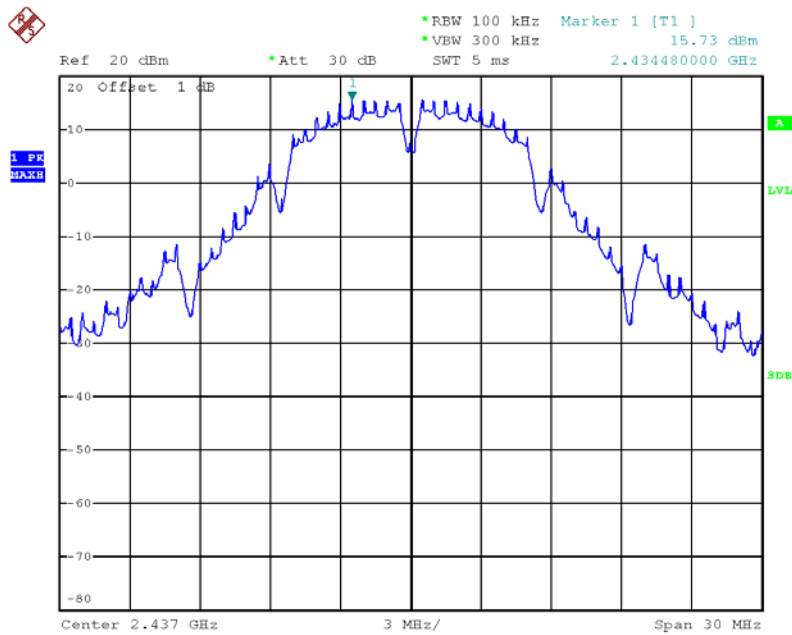

Date: 28.DEC.2012 17:10:28

Plot on Configuration IEEE 802.11b / CH 1 (down 30dBc)

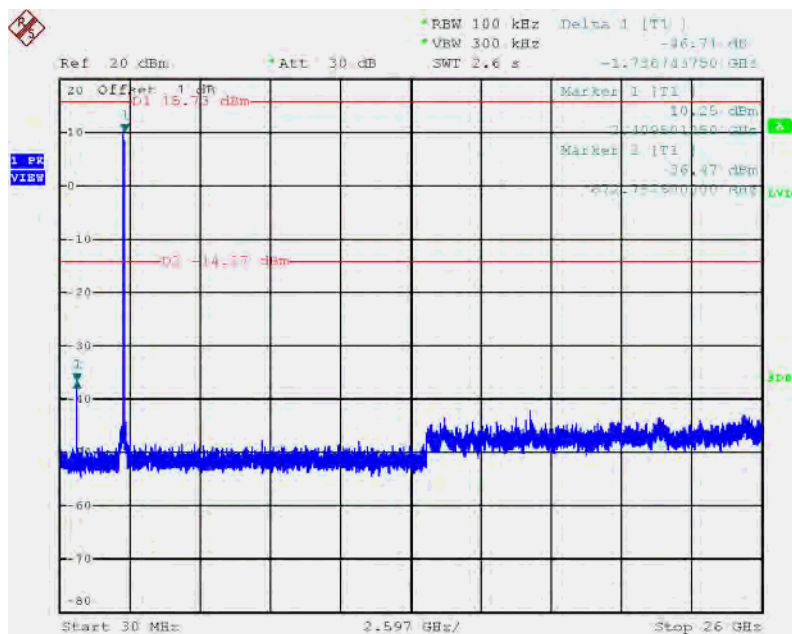

Date: 28.DEC.2012 17:23:43

Plot on Configuration IEEE 802.11b / CH 6 (down 30dBc)

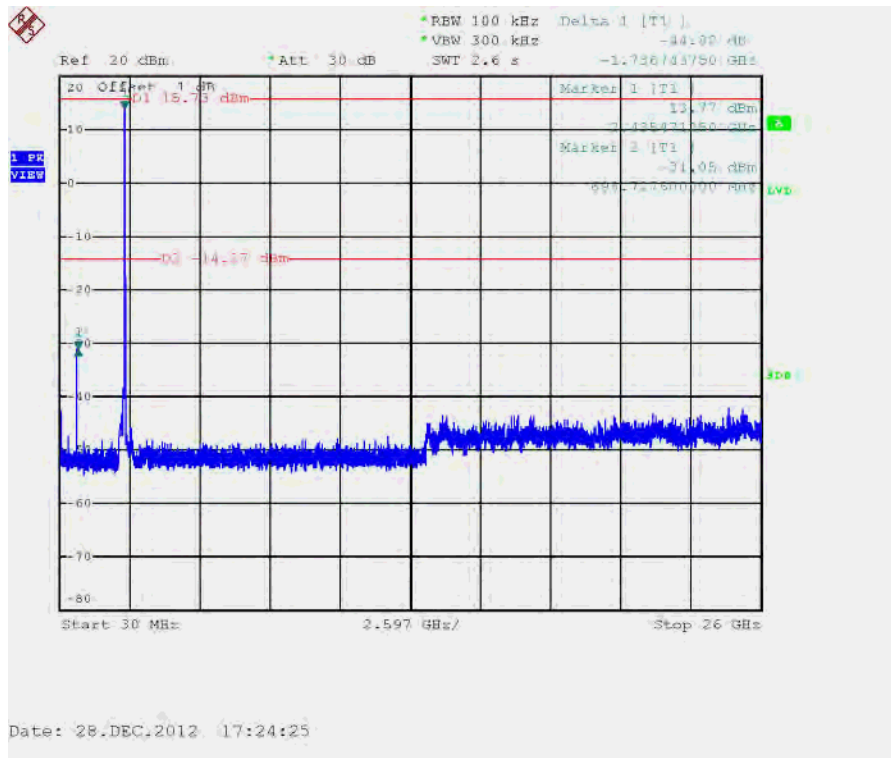

Plot on Configuration IEEE 802.11b / CH 11 (down 30dBc)

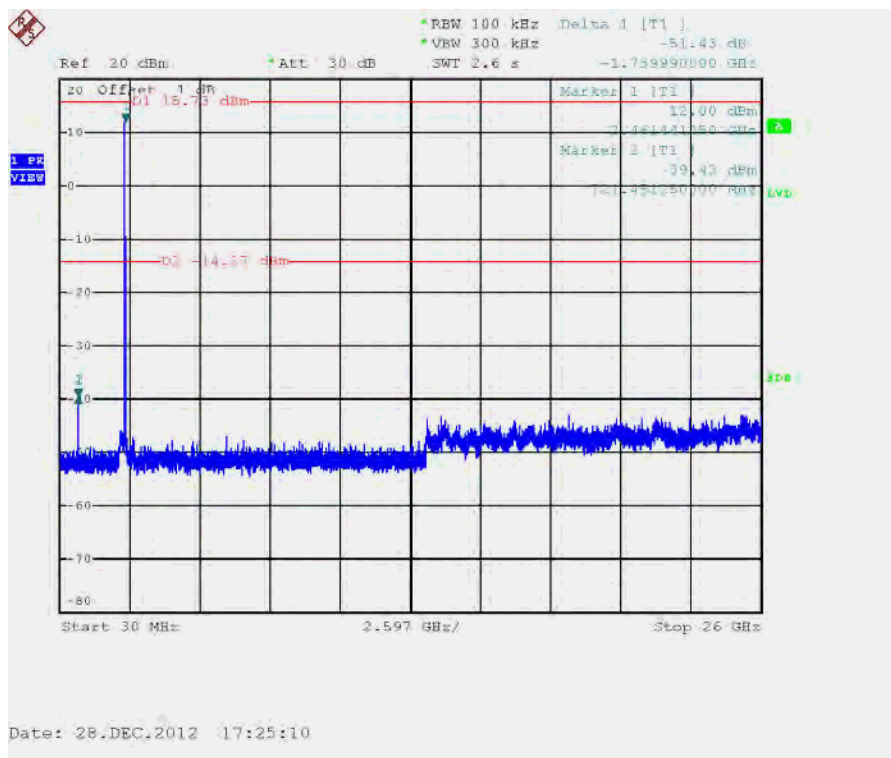

Plot on Configuration IEEE 802.11g / Reference Level

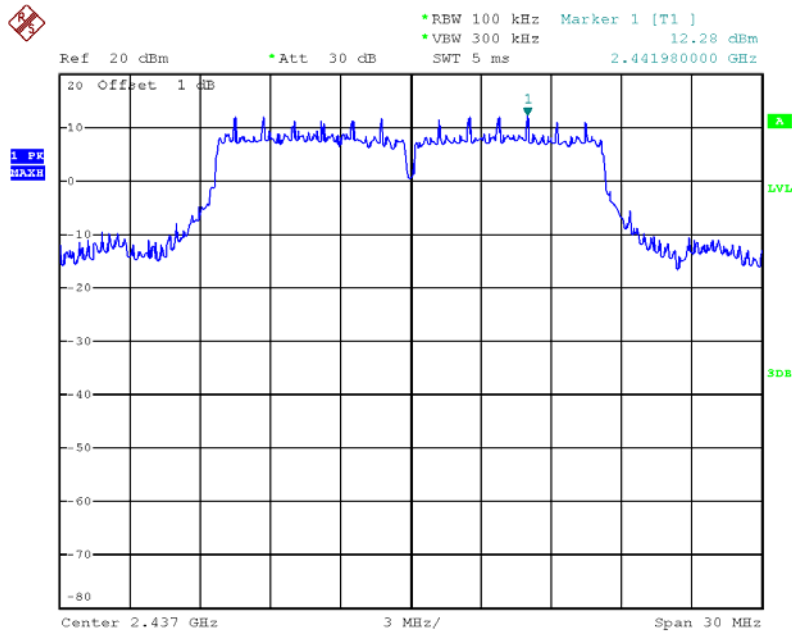

Date: 28.DEC.2012 17:12:45

Plot on Configuration IEEE 802.11g / CH 1 (down 30dBc)

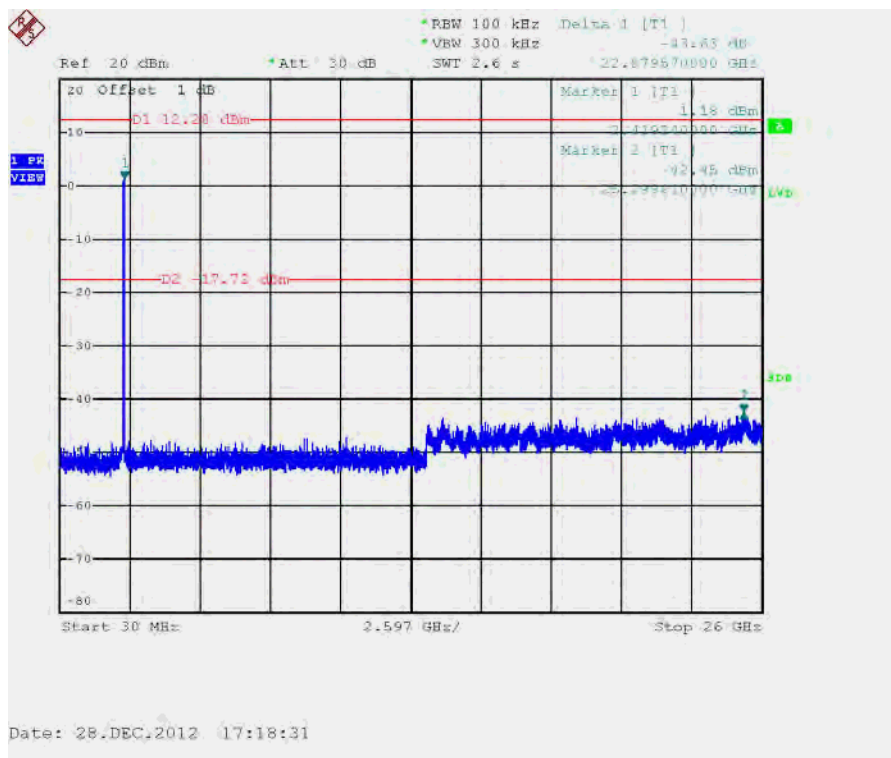

Plot on Configuration IEEE 802.11g / CH 6 (down 30dBc)

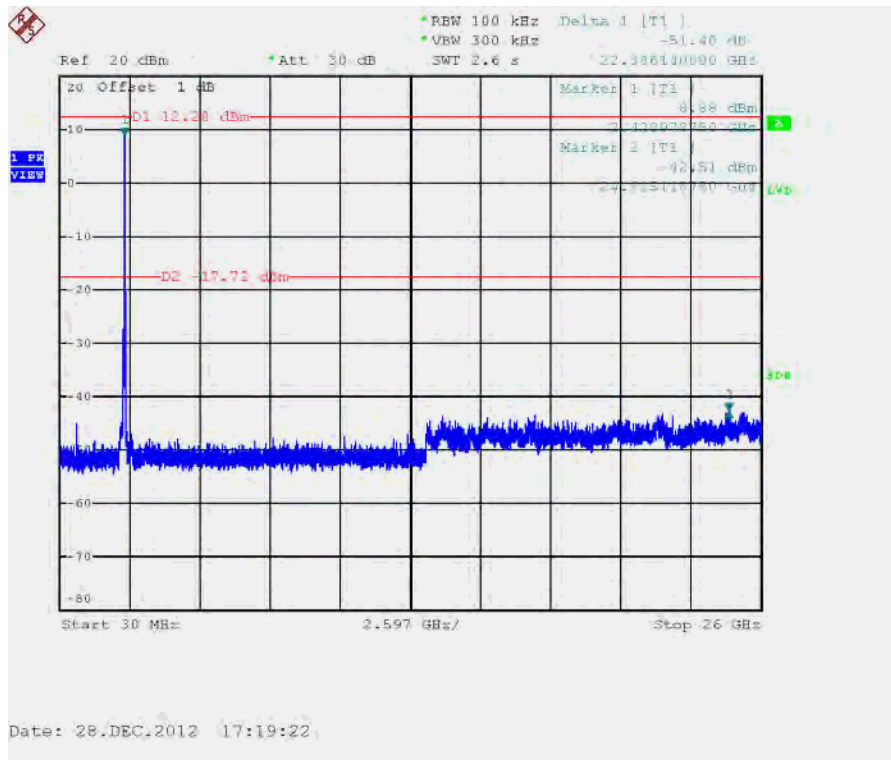

Plot on Configuration IEEE 802.11g / CH 11 (down 30dBc)

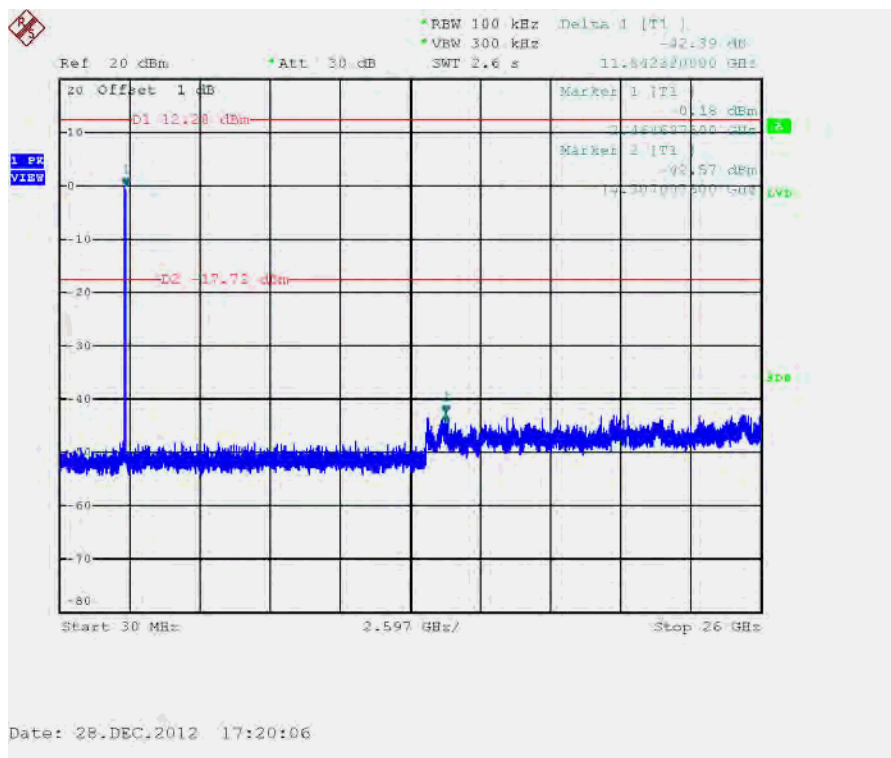

## 4.7. Antenna Requirements

### 4.7.1. Limit

Except for special regulations, the Low-power Radio-frequency Devices must not be equipped with any jacket for installing an antenna with extension cable. An intentional radiator shall be designed to ensure that no antenna other than that furnished by the responsible party shall be used with the device. The use of a permanently attached antenna or of an antenna that uses a unique coupling to the intentional radiator shall be considered sufficient to comply with the provisions of this Section. The manufacturer may design the unit so that the user can replace a broken antenna, but the use of a standard antenna jack or electrical connector is prohibited. Further, this requirement does not apply to intentional radiators that must be professionally installed.

### 4.7.2. Antenna Connector Construction

Please refer to section 3.3 in this test report; antenna connector complied with the requirements.



## 5. LIST OF MEASURING EQUIPMENTS

Instrument	Manufacturer	Model No.	Serial No.	Characteristics	Calibration Date	Remark
EMI Test Receiver	R&S	ESCS 30	100377	9kHz ~ 2.75GHz	Oct. 23, 2012	Conduction (CO01-CB)
LISN	F.C.C.	FCC-LISN-50-16-2	04083	150kHz ~ 100MHz	Nov. 26, 2012	Conduction (CO01-CB)
V- LISN	Schwarzbeck	NSLK 8127	8127-478	9kHz ~ 30MHz	Jun. 22, 2012	Conduction (CO01-CB)
Impulsbegrenzer Pulse Limiter	Rohde&Schwarz	ESH3-Z2	100430	9kHz~30MHz	Feb. 03, 2012	Conduction (CO01-CB)
COND Cable	Woken	Cable	01	0.15MHz~30MHz	Dec. 04, 2012	Conduction (CO01-CB)
BILOG ANTENNA	Schaffner	CBL6112D	22021	20MHz ~ 2GHz	Jan. 11, 2012	Radiation (03CH01-CB)
Horn Antenna	EMCO	3115	00075790	750MHz~18GHz	Nov. 27, 2012	Radiation (03CH01-CB)
Horn Antenna	SCHWARZBEAK	BBHA 9170	BBHA9170252	15GHz ~ 40GHz	Nov. 23, 2012	Radiation (03CH01-CB)
Pre-Amplifier	Agilent	8447D	2944A10991	0.1MHz ~ 1.3GHz	Nov. 27, 2012	Radiation (03CH01-CB)
Pre-Amplifier	Agilent	8449B	3008A02310	1GHz ~ 26.5GHz	Nov. 23, 2012	Radiation (03CH01-CB)
Pre-Amplifier	WM	TF-130N-R1	923365	26.5GHz ~ 40GHz	Jul. 31, 2012	Radiation (03CH01-CB)
Spectrum analyzer	R&S	FSP40	100056	9KHz~40GHz	Nov. 16, 2012	Radiation (05CH01-CB)
EMI Test Receiver	R&S	ESCS 30	100355	9KHz ~ 2.75GHz	Mar. 20, 2012	Radiation (03CH01-CB)
Turn Table	INN CO	CO 2000	N/A	0 ~ 360 degree	N.C.R	Radiation (03CH01-CB)
Antenna Mast	INN CO	CO2000	N/A	1 m - 4 m	N.C.R	Radiation (03CH01-CB)
RF Cable-low	Woken	Low Cable-1	N/A	30 MHz - 1 GHz	Nov. 18, 2012	Radiation (03CH01-CB)
RF Cable-high	Woken	High Cable-1	N/A	1 GHz – 26.5 GHz	Nov. 18, 2012	Radiation (03CH01-CB)
RF Cable-high	Woken	High Cable-2	N/A	1 GHz – 26.5 GHz	Nov. 18, 2012	Radiation (03CH01-CB)
RF Cable-high	Woken	High Cable-3	N/A	1 GHz - 40 GHz	Nov. 18, 2012	Radiation (03CH01-CB)
RF Cable-high	Woken	High Cable-4	N/A	1 GHz - 40 GHz	Nov. 18, 2012	Radiation (03CH01-CB)
Loop Antenna	Teseq	HLA 6120	24155	9 kHz - 30 MHz	Nov. 05, 2012*	Radiation (03CH01-CB)
Signal analyzer	R&S	FSV40	100979	9KHz~40GHz	Oct. 08, 2012	Conducted (TH01-CB)
Temp. and Humidity Chamber	Ten Billion	TTH-D3SP	TBN-931011	-30~100 degree	Jun. 05, 2012	Conducted (TH01-CB)
RF Power Divider	Woken	2 Way	0120A02056002D	2GHz ~ 18GHz	Nov. 18, 2012	Conducted (TH01-CB)
RF Power Divider	Woken	3 Way	MDC2366	2GHz ~ 18GHz	Nov. 18, 2012	Conducted (TH01-CB)
RF Power Divider	Woken	4 Way	0120A04056002D	2GHz ~ 18GHz	Nov. 18, 2012	Conducted (TH01-CB)

Instrument	Manufacturer	Model No.	Serial No.	Characteristics	Calibration Date	Remark
RF Cable-high	Woken	High Cable-7	-	1 GHz – 26.5 GHz	Nov. 19, 2012	Conducted (TH01-CB)
RF Cable-high	Woken	High Cable-8	-	1 GHz – 26.5 GHz	Nov. 19, 2012	Conducted (TH01-CB)
RF Cable-high	Woken	High Cable-9	-	1 GHz – 26.5 GHz	Nov. 19, 2012	Conducted (TH01-CB)
RF Cable-high	Woken	High Cable-10	-	1 GHz – 26.5 GHz	Nov. 19, 2012	Conducted (TH01-CB)
RF Cable-high	Woken	High Cable-11	-	1 GHz – 26.5 GHz	Nov. 19, 2012	Conducted (TH01-CB)
Power Sensor	Anritsu	MA2411B	0917223	300MHz~40GHz	Nov. 28, 2012	Conducted (TH01-CB)
Power Meter	Anritsu	ML2495A	1035008	300MHz~40GHz	Nov. 27, 2012	Conducted (TH01-CB)

Note: Calibration Interval of instruments listed above is one year.

\* Calibration Interval of instruments listed above is two year.

N.C.R. means Non-Calibration required.

## 6. TEST LOCATION

SHIJR	ADD : 6Fl., No. 106, Sec. 1, Shintai 5th Rd., Shijr City, Taipei, Taiwan 221, R.O.C. TEL : 886-2-2696-2468 FAX : 886-2-2696-2255
HWA YA	ADD : No. 52, Hwa Ya 1st Rd., Kwei-Shan Hsiang, Tao Yuan Hsien, Taiwan, R.O.C. TEL : 886-3-327-3456 FAX : 886-3-318-0055
LINKOU	ADD : No. 30-2, Dingfu Tsuen, Linkou Shiang, Taipei, Taiwan 244, R.O.C TEL : 886-2-2601-1640 FAX : 886-2-2601-1695
DUNGHU	ADD : No. 3, Lane 238, Kangle St., Neihu Chiu, Taipei, Taiwan 114, R.O.C. TEL : 886-2-2631-4739 FAX : 886-2-2631-9740
JUNGHE	ADD : 7Fl., No. 758, Jungjeng Rd., Junghe City, Taipei, Taiwan 235, R.O.C. TEL : 886-2-8227-2020 FAX : 886-2-8227-2626
NEIHU	ADD : 4Fl., No. 339, Hsin Hu 2 <sup>nd</sup> Rd., Taipei 114, Taiwan, R.O.C. TEL : 886-2-2794-8886 FAX : 886-2-2794-9777
JHUBEI	ADD : No.8, Lane 724, Bo-ai St., Jhubei City, HsinChu County 302, Taiwan, R.O.C. TEL : 886-3-656-9065 FAX : 886-3-656-9085