



# SPORTON International Inc.

No. 52, Hwa Ya 1st Rd., Kwei-Shan Hsiang, TaoYuan Hsien, Taiwan, R.O.C.  
Ph: 886-3-327-3456 / FAX: 886-3-327-0973 / www.sporton.com.tw

## FCC RADIO TEST REPORT

Applicant's company	PEGATRON CORPORATION
Applicant Address	5F., NO. 76, LIGONG ST., BEITOU DISTRICT, TAIPEI CITY 112 Taiwan
FCC ID	VUIUPWL6031C
Manufacturer's company	PEGATRON CORPORATION
Manufacturer Address	5F., NO. 76, LIGONG ST., BEITOU DISTRICT, TAIPEI CITY 112 Taiwan

Product Name	Wireless module
Brand Name	PEGATRON
Model Name.	UPWL6031C
Test Rule Part(s)	47 CFR FCC Part 15 Subpart E § 15.407
Test Freq. Range	5150 ~ 5350MHz / 5470 ~ 5725MHz
Received Date	Feb. 08, 2013
Final Test Date	Apr. 09, 2013
Submission Type	Original Equipment
Operating Mode	Client (without radar detection function)

### Statement

Test result included is for the IEEE 802.11n and IEEE 802.11a (5150 ~ 5350MHz / 5470 ~ 5725MHz) of the product.

The test result in this report refers exclusively to the presented test model / sample.

Without written approval of SPORTON International Inc., the test report shall not be reproduced except in full.

The measurements and test results shown in this test report were made in accordance with the procedures and found in compliance with the limit given in ANSI C63.10-2009, 47 CFR FCC Part 15 Subpart E, KDB 789033 D01 v01r02 and KDB 662911 D01 v01r02.

The test equipment used to perform the test is calibrated and traceable to NML/ROC.



## Table of Contents

<b>1. CERTIFICATE OF COMPLIANCE .....</b>	<b>1</b>
<b>2. SUMMARY OF THE TEST RESULT .....</b>	<b>2</b>
<b>3. GENERAL INFORMATION .....</b>	<b>3</b>
3.1. Product Details.....	3
3.2. Accessories.....	4
3.3. Table for Filed Antenna.....	5
3.4. Table for Carrier Frequencies .....	7
3.5. Table for Test Modes.....	8
3.6. Table for Testing Locations.....	10
3.7. Table for Supporting Units .....	10
3.8. Table for Parameters of Test Software Setting .....	11
3.9. Test Configurations .....	12
<b>4. TEST RESULT .....</b>	<b>15</b>
4.1. AC Power Line Conducted Emissions Measurement.....	15
4.2. 26dB Bandwidth Measurement.....	19
4.3. Maximum Conducted Output Power Measurement.....	35
4.4. Power Spectral Density Measurement .....	39
4.5. Peak Excursion Measurement .....	48
4.6. Radiated Emissions Measurement .....	56
4.7. Band Edge Emissions Measurement .....	87
4.8. Frequency Stability Measurement .....	97
4.9. Antenna Requirements .....	99
<b>5. LIST OF MEASURING EQUIPMENTS .....</b>	<b>100</b>
<b>6. TEST LOCATION.....</b>	<b>102</b>
<b>APPENDIX A. TEST PHOTOS .....</b>	<b>A1 ~ A5</b>
<b>APPENDIX B. MAXIMUM PERMISSIBLE EXPOSURE .....</b>	<b>B1 ~ B3</b>



### History of This Test Report

REPORT NO.	VERSION	DESCRIPTION	ISSUED DATE
FR320831AB	Rev. 01	Initial issue of report	Apr. 15, 2013



## 1. CERTIFICATE OF COMPLIANCE

Product Name : Wireless module  
Brand Name : PEGATRON  
Model Name : UPWL6031C  
Applicant : PEGATRON CORPORATION  
Test Rule Part(s) : 47 CFR FCC Part 15 Subpart E § 15.407

Sporton International as requested by the applicant to evaluate the EMC performance of the product sample received on Feb. 08, 2013 would like to declare that the tested sample has been evaluated and found to be in compliance with the tested rule parts. The data recorded as well as the test configuration specified is true and accurate for showing the sample's EMC nature.

A handwritten signature in blue ink, appearing to read "Sam Chen", is written over a horizontal line.

Sam Chen

SPORTON INTERNATIONAL INC.

## 2. SUMMARY OF THE TEST RESULT

Applied Standard: 47 CFR FCC Part 15 Subpart E				
Part	Rule Section	Description of Test	Result	Under Limit
4.1	15.207	AC Power Line Conducted Emissions	Complies	13.43 dB
4.2	15.407(a)	26dB Spectrum Bandwidth	Complies	-
4.3	15.407(a)	Maximum Conducted Output Power	Complies	0.11 dB
4.4	15.407(a)	Power Spectral Density	Complies	0.11 dB
4.5	15.407(a)	Peak Excursion	Complies	3.50 dB
4.6	15.407(b)	Radiated Emissions	Complies	3.02 dB
4.7	15.407(b)	Band Edge Emissions	Complies	0.25 dB
4.8	15.407(g)	Frequency Stability	Complies	-
4.9	15.203	Antenna Requirements	Complies	-

Test Items	Uncertainty	Remark
AC Power Line Conducted Emissions	±2.3dB	Confidence levels of 95%
Maximum Conducted Output Power	±0.5dB	Confidence levels of 95%
Power Spectral Density	±0.5dB	Confidence levels of 95%
Peak Excursion	±0.5dB	Confidence levels of 95%
26dB Spectrum Bandwidth / Frequency Stability	±8.5×10 <sup>-8</sup>	Confidence levels of 95%
Radiated Emissions (9kHz~30MHz)	±0.8dB	Confidence levels of 95%
Radiated Emissions (30MHz~1000MHz)	±1.9dB	Confidence levels of 95%
Radiated / Band Edge Emissions (1GHz~18GHz)	±1.9dB	Confidence levels of 95%
Radiated Emissions (18GHz~40GHz)	±1.9dB	Confidence levels of 95%
Temperature	±0.7°C	Confidence levels of 95%
Humidity	±3.2%	Confidence levels of 95%
DC / AC Power Source	±1.4%	Confidence levels of 95%

### 3. GENERAL INFORMATION

#### 3.1. Product Details

##### IEEE 802.11n

Items	Description
Product Type	WLAN (3TX, 3RX)
Radio Type	Intentional Transceiver
Power Type	From Host System
Modulation	see the below table for IEEE 802.11n
Data Modulation	OFDM (BPSK / QPSK / 16QAM / 64QAM)
Data Rate (Mbps)	see the below table for IEEE 802.11n
Frequency Range	5150 ~ 5350MHz / 5470 ~ 5725MHz
Channel Number	16 for 20MHz bandwidth ; 7 for 40MHz bandwidth
Channel Band Width (99%)	MCS0 (20MHz): 20.32 MHz ; MCS0 (40MHz): 43.84 MHz
Maximum Conducted Output Power	Band 1: MCS0 (20MHz): 15.74 dBm ; MCS0 (40MHz): 16.75 dBm Band 2: MCS0 (20MHz): 22.58 dBm ; MCS0 (40MHz): 23.72 dBm Band 3: MCS0 (20MHz): 21.76 dBm ; MCS0 (40MHz): 23.33 dBm
Carrier Frequencies	Please refer to section 3.4
Antenna	Please refer to section 3.3

##### IEEE 802.11a

Items	Description
Product Type	WLAN (1TX, 3RX)
Radio Type	Intentional Transceiver
Power Type	From Host System
Modulation	OFDM for IEEE 802.11a
Data Modulation	OFDM (BPSK / QPSK / 16QAM / 64QAM)
Data Rate (Mbps)	OFDM (6/9/12/18/24/36/48/54)
Frequency Range	5150 ~ 5350MHz / 5470 ~ 5725MHz
Channel Number	16
Channel Band Width (99%)	11a: 37.92 MHz
Maximum Conducted Output Power	Band 1: 16.89 dBm ; Band 2: 22.91 dBm ; Band 3: 21.42 dBm
Carrier Frequencies	Please refer to section 3.4
Antenna	Please refer to section 3.3

**Antenna & Band width**

Antenna	Single (TX)		Three (TX)	
	20 MHz	40 MHz	20 MHz	40 MHz
IEEE 802.11a	V	X	X	X
IEEE 802.11n	X	X	V	V

**IEEE 11n Spec.**

Protocol	Number of Transmit Chains (NTX)	Data Rate / MCS
802.11n (HT20)	3	M0-23
802.11n (HT40)	3	M0-23

Note 1: IEEE Std. 802.11n modulation consists of HT20 and HT40 (HT: High Throughput). Then EUT support HT20 and HT40.

Note 2: Modulation modes consist of below configuration:  
HT20/HT40: IEEE 802.11n

**3.2. Accessories**

N/A

### 3.3. Table for Filed Antenna

Ant.	Brand Holder	Model Name	Antenna Type	Connector	Gain (dBi)	
					2.4GHz	5GHz
1	HL Technology	260-26021	PCB Antenna	I-PEX	3.34	-
2	HL Technology	260-26022	PCB Antenna	I-PEX	2.32	2.52
3	HL Technology	260-26023	PCB Antenna	I-PEX	4.64	2.73
4	HL Technology	260-26027	PCB Antenna	I-PEX	3.57	-
5	HL Technology	260-26028	PCB Antenna	I-PEX	2.58	-
6	HL Technology	260-26029	PCB Antenna	I-PEX	2.7	-
7	HL Technology	260-26030	PCB Antenna	I-PEX	2.06	2.68
8	HL Technology	260-26031	PCB Antenna	I-PEX	3.88	2.77
9	HL Technology	260-26032	PCB Antenna	I-PEX	3.65	2.56
10	HL Technology	260-26033	PCB Antenna	I-PEX	3.34	-
11	HL Technology	260-26034	PCB Antenna	I-PEX	2.65	-
12	HL Technology	260-26035	PCB Antenna	I-PEX	4.22	-
13	HL Technology	260-26038	PCB Antenna	I-PEX	2.2	2.65
14	HL Technology	260-26039	PCB Antenna	I-PEX	1.92	2.49
15	Wanshih Electronic Co., Ltd.	UC3WFI0095	PCB Antenna	I-PEX	4.45	2.76
16	Wanshih Electronic Co., Ltd.	UC3WFI0063	PCB Antenna	I-PEX	2.04	2.68
17	Wanshih Electronic Co., Ltd.	UC3WFI0064	PCB Antenna	I-PEX	3.9	2.73

Note1:

**For 2.4GHz Function:**

Ant.1~17 are the same antenna type in the antenna list, antenna 3 is the highest gain antenna.

It was selected to perform the test and recorded in this report.

**For 5GHz Function:**

Ant.2~3, 7~9 and 13~17 are the same antenna type in the antenna list, antenna 8 is the highest gain antenna.

It was selected to perform the test and recorded in this report.



Note2:

**For IEEE 802.11b/g mode (1TX/3RX):**

Only Chain. 1 can be use as transmit antenna.

Chain. 1, Chain. 2 and Chain. 3 could both receive simultaneously.

**For IEEE 802.11a mode (1TX/3RX):**

Only Chain. 1 can be use as transmit antenna.

Chain. 1, Chain. 2 and Chain. 3 could both receive simultaneously.

**For IEEE 802.11n mode (3TX/3RX):**

Chain. 1, Chain. 2 and Chain. 3 can be used as transmitting/receiving antenna.

Chain. 1, Chain. 2 and Chain. 3 could both transmit/receive simultaneously.

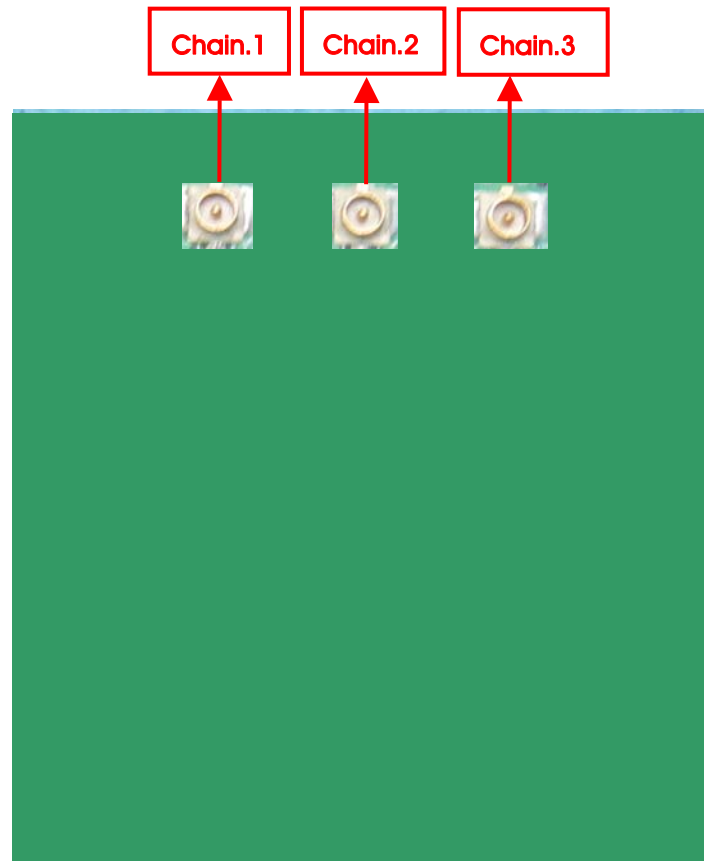

### 3.4. Table for Carrier Frequencies

The EUT has two bandwidth system.

For 20MHz bandwidth systems, use Channel 36, 40, 44, 48, 52, 56, 60, 64, 100, 104, 108, 112, 116, 132, 136, 140.

For 40MHz bandwidth systems, use Channel 38, 46, 54, 62, 102, 110, 134.

Frequency Band	Channel No.	Frequency	Channel No.	Frequency
5150~5250 MHz Band 1	36	5180 MHz	44	5220 MHz
	38	5190 MHz	46	5230 MHz
	40	5200 MHz	48	5240 MHz
5250~5350 MHz Band 2	52	5260 MHz	60	5300 MHz
	54	5270 MHz	62	5310 MHz
	56	5280 MHz	64	5320 MHz
5470~5725 MHz Band 3	100	5500 MHz	116	5580 MHz
	102	5510MHz	132	5660 MHz
	104	5520 MHz	134	5670 MHz
	108	5540 MHz	136	5680 MHz
	110	5550 MHz	140	5700 MHz
	112	5560 MHz	-	-

### 3.5. Table for Test Modes

Preliminary tests were performed in different data rate to find the worst radiated emission. The data rate shown in the table below is the worst-case rate with respect to the specific test item. Investigation has been done on all the possible configurations for searching the worst cases. The following table is a list of the test modes shown in this test report.

Test Items	Mode		Data Rate	Channel	Chain
AC Power Conducted Emission	Normal Link		Auto	-	-
Max. Conducted Output Power	11n 20MHz	Band 1~2	MCS0	36/40/48/52/60/64	1+2+3
		Band 3	MCS0	100/116/140	1+2+3
	11n 40MHz	Band 1~2	MCS0	38/46/54/62	1+2+3
		Band 3	MCS0	102/110 /134	1+2+3
	11a/BPSK	Band 1~2	6Mbps	36/40/48/52/60/64	1
		Band 3	6Mbps	100/116/140	1
Power Spectral Density	11n 20MHz	Band 1~2	MCS0	36/40/48/52/60/64	1+2+3
		Band 3	MCS0	100/116/140	1+2+3
	11n 40MHz	Band 1~2	MCS0	38/46/54/62	1+2+3
		Band 3	MCS0	102/110 /134	1+2+3
	11a/BPSK	Band 1~2	6Mbps	36/40/48/52/60/64	1
		Band 3	6Mbps	100/116/140	1
26dB Spectrum Bandwidth 99% Occupied Bandwidth Measurement Peak Excursion	11n 20MHz	Band 1~2	MCS0	36/40/48/52/60/64	1+2+3
		Band 3	MCS0	100/116/140	1+2+3
	11n 40MHz	Band 1~2	MCS0	38/46/54/62	1+2+3
		Band 3	MCS0	102/110 /134	1+2+3
	11a/BPSK	Band 1~2	6Mbps	36/40/48/52/60/64	1
		Band 3	6Mbps	100/116/140	1
Radiated Emission Below 1GHz	Normal Link		Auto	-	-
Radiated Emission Above 1GHz	11n 20MHz	Band 1~2	MCS0	36/40/48/52/60/64	1+2+3
		Band 3	MCS0	100/116/140	1+2+3
	11n 40MHz	Band 1~2	MCS0	38/46/54/62	1+2+3
		Band 3	MCS0	102/110 /134	1+2+3
	11a/BPSK	Band 1~2	6Mbps	36/40/48/52/60/64	1
		Band 3	6Mbps	100/116/140	1

Band Edge Emission	11n 20MHz	Band 1~2	MCS0	36/40/48/52/60/64	1+2+3
		Band 3	MCS0	100/116/140	1+2+3
	11n 40MHz	Band 1~2	MCS0	38/46/54/62	1+2+3
		Band 3	MCS0	102/110 /134	1+2+3
	11a/BPSK	Band 1~2	6Mbps	36/40/48/52/60/64	1
		Band 3	6Mbps	100/140	1
Frequency Stability	Un-modulation		-	40	N/A

The following test modes were performed for all tests:

**For Conducted Emission test:**

Mode 1. Normal Link for 2.4GHz

Mode 2. Normal Link for 5GHz

Due to Mode 2 generated the worst test result, it was recorded in this report.

**For Radiated Emission test:**

< Below 1G >

Mode 1. Normal Link for 2.4GHz

Mode 2. Normal Link for 5GHz

Due to Mode 1 generated the worst test result, it was recorded in this report.

< Above 1G >

Mode 1. CTX

### 3.6. Table for Testing Locations

Test Site No.	Site Category	Location	FCC Reg. No.	IC File No.
03CH01-CB	SAC	Hsin Chu	262045	IC 4086D
CO01-CB	Conduction	Hsin Chu	262045	IC 4086D
TH01-CB	OVEN Room	Hsin Chu	-	-

Open Area Test Site (OATS); Semi Anechoic Chamber (SAC).

Please refer section 6 for Test Site Address.

### 3.7. Table for Supporting Units

For Test Site No : 03CH01-CB / CO01-CB

Support Unit	Brand	Model	FCC ID
Notebook	DELL	E6220	QDS-BRCM1049LE
Mouse	Logitech	M-U0026	DoC
Earphone	SHYARO CHI	MIC-04	N/A
Wireless AP	BELKIN	WG7016G22-LF-AK	DoC

For Test Site No : TH01-CB

Support Unit	Brand	Model	FCC ID
Notebook	DELL	M1330	E2KWM3945ABG

### 3.8. Table for Parameters of Test Software Setting

During testing, Channel & Power Controlling Software provided by the customer was used to control the operating channel as well as the output power level. The RF output power selection is for the setting of RF output power expected by the customer and is going to be fixed on the firmware of the final end product.

#### Power Parameters of IEEE 802.11n MCS0 20MHz

Test Software Version	Manual Tool Version : 1.0.0.9								
Frequency	5180 MHz	5200 MHz	5240 MHz	5260 MHz	5300 MHz	5320 MHz	5500 MHz	5580 MHz	5700 MHz
MCS0 20MHz	37	36	36	68	68	64	39	66	59

#### Power Parameters of IEEE 802.11n MCS0 40MHz

Test Software Version	Manual Tool Version : 1.0.0.9						
Frequency	5190 MHz	5230 MHz	5270 MHz	5310 MHz	5510 MHz	5550 MHz	5670 MHz
MCS0 40MHz	38	38	72	38	36	72	66

#### Power Parameters of IEEE 802.11a

Test Software Version	Manual Tool Version : 1.0.0.9								
Frequency	5180 MHz	5200 MHz	5240 MHz	5260 MHz	5300 MHz	5320 MHz	5500 MHz	5580 MHz	5700 MHz
IEEE 802.11a	60	61	61	100	82	72	70	100	64

### 3.9. Test Configurations

#### 3.9.1. AC Power Line Conduction Emissions Test Configuration

Test Mode : Mode 2

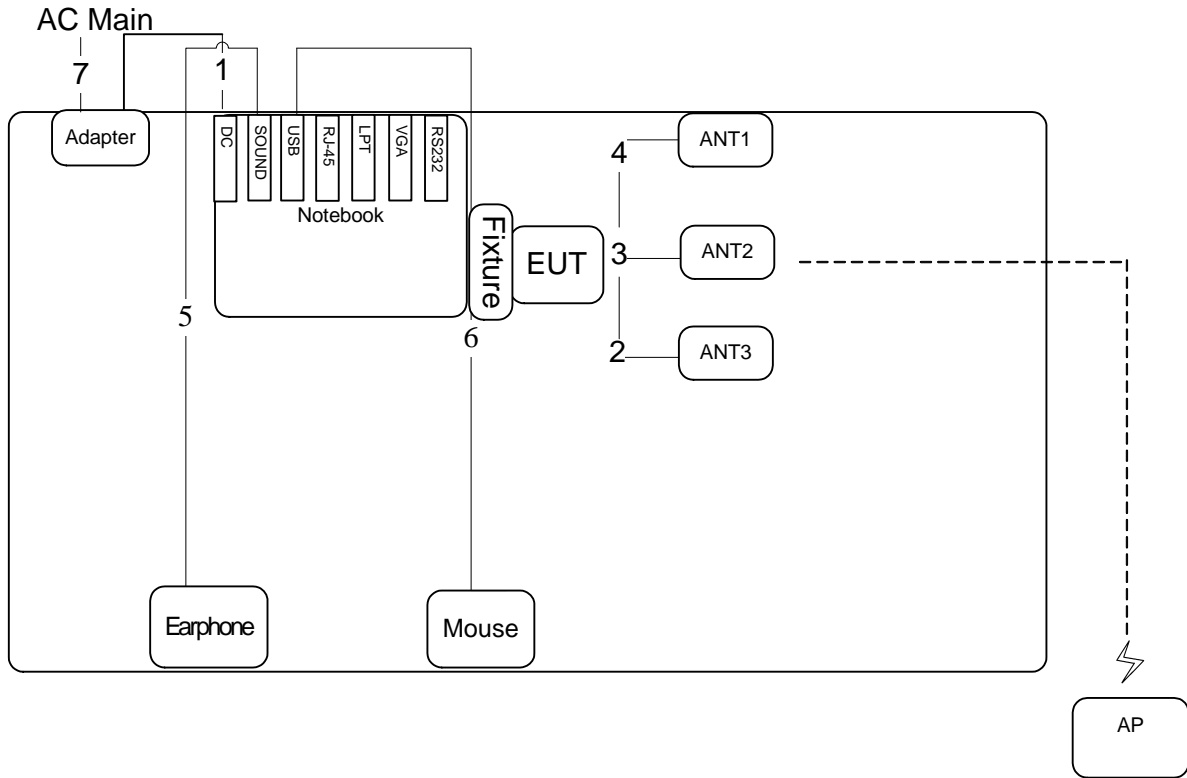

Item	Connection	Shield	Length
1	DC Power Cable	No	0.8m
2	Ant Cable	Yes	0.12m
3	Ant Cable	Yes	0.12m
4	Ant Cable	Yes	0.12m
5	Audio Cable	No	1.1m
6	USB Cable	No	1.5m
7	AC Power Cable	No	1.8m

### 3.9.2. Radiation Emissions Test Configuration

Test Configuration: 30MHz ~ 1GHz

Test Mode : Mode 1

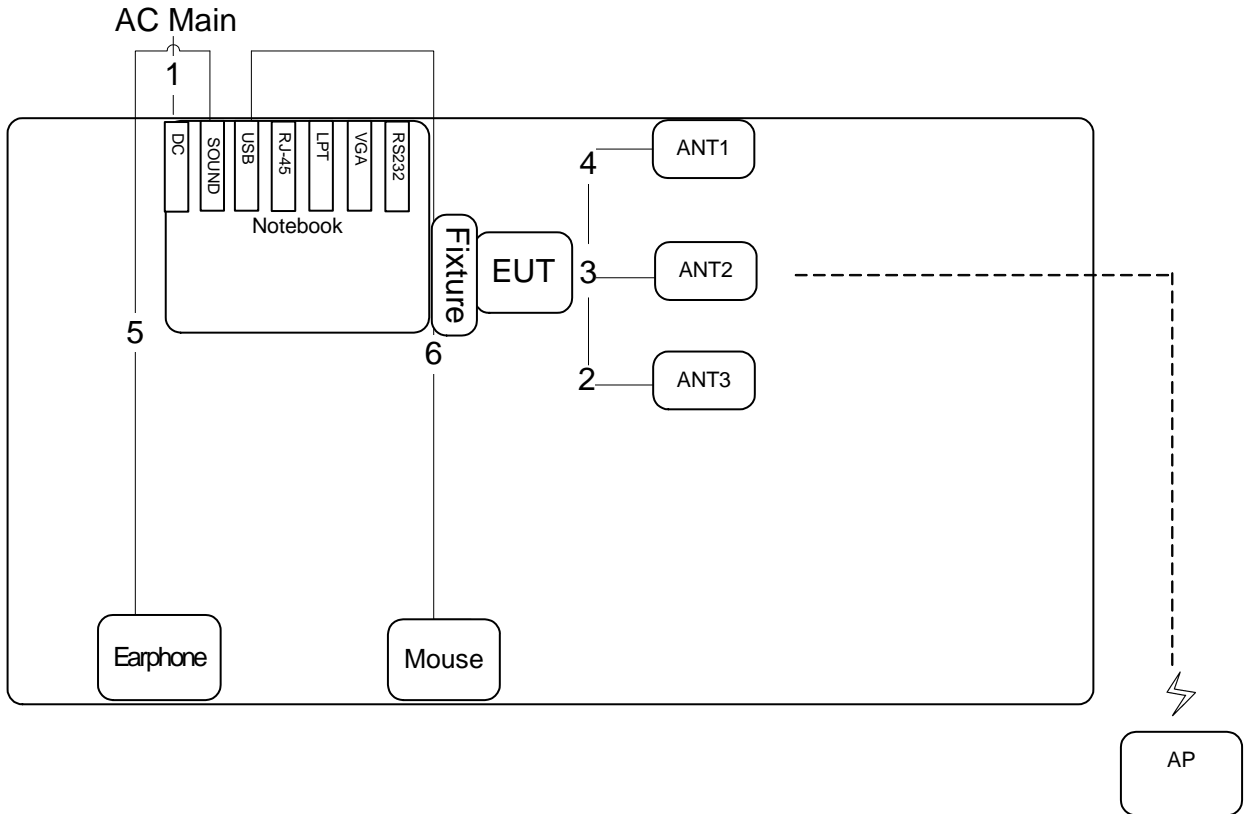

Item	Connection	Shield	Length
1	AC Power Cable	No	1.8m
2	Ant Cable	Yes	0.12m
3	Ant Cable	Yes	0.12m
4	Ant Cable	Yes	0.12m
5	Audio Cable	No	1.1m
6	USB Cable	No	1.5m



Test Configuration: above 1GHz

Test Mode : Mode 1

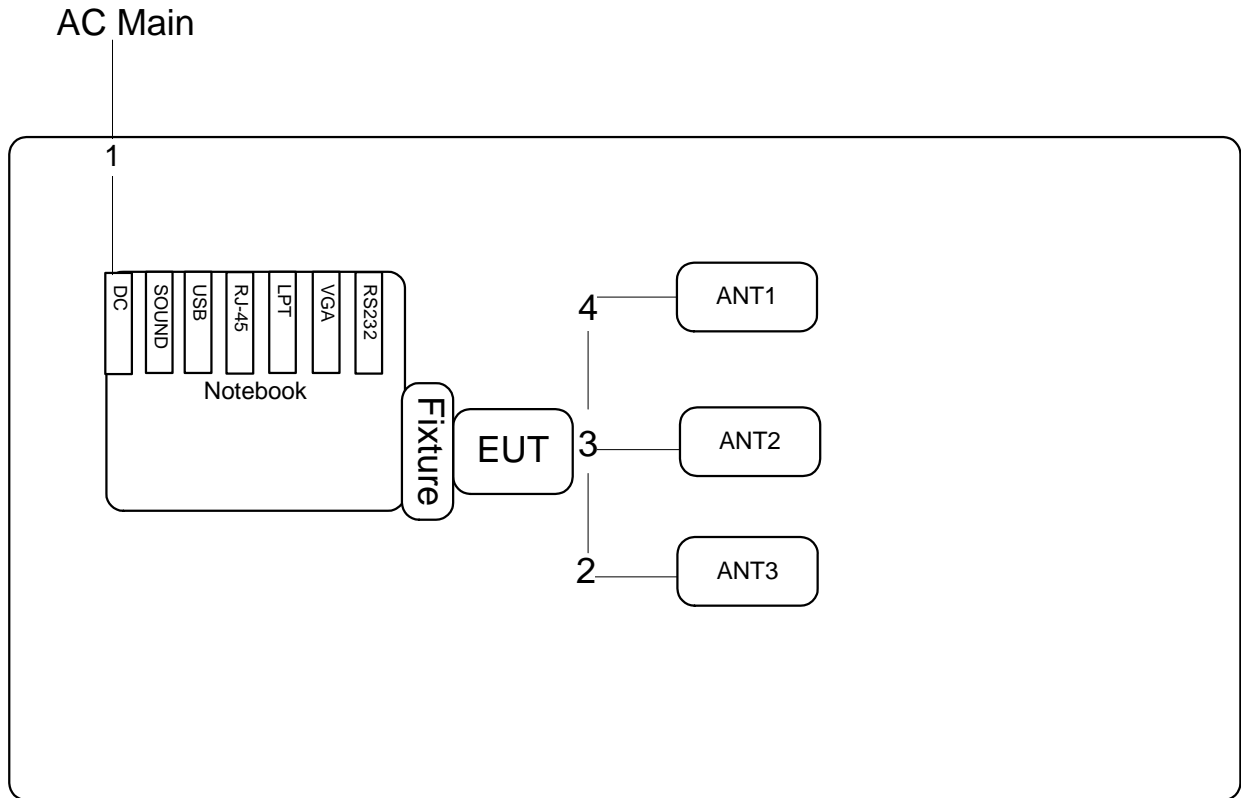

Item	Connection	Shield	Length
1	AC Power Cable	No	1.8m
2	Ant Cable	Yes	0.12m
3	Ant Cable	Yes	0.12m
4	Ant Cable	Yes	0.12m

## 4. TEST RESULT

### 4.1. AC Power Line Conducted Emissions Measurement

#### 4.1.1. Limit

For this product that is designed to connect to the AC power line, the radio frequency voltage that is conducted back onto the AC power line on any frequency or frequencies within the band 150 kHz to 30 MHz shall not exceed below limits table.

Frequency (MHz)	QP Limit (dBuV)	AV Limit (dBuV)
0.15~0.5	66~56	56~46
0.5~5	56	46
5~30	60	50

#### 4.1.2. Measuring Instruments and Setting

Please refer to section 5 of equipments list in this report. The following table is the setting of the receiver.

Receiver Parameters	Setting
Attenuation	10 dB
Start Frequency	0.15 MHz
Stop Frequency	30 MHz
IF Bandwidth	9 KHz

#### 4.1.3. Test Procedures

1. Configure the EUT according to ANSI C63.10. The EUT or host of EUT has to be placed 0.4 meter far from the conducting wall of the shielding room and at least 80 centimeters from any other grounded conducting surface.
2. Connect EUT or host of EUT to the power mains through a line impedance stabilization network (LISN).
3. All the support units are connected to the other LISNs. The LISN should provide 50uH/50ohms coupling impedance.
4. The frequency range from 150 KHz to 30 MHz was searched.
5. Set the test-receiver system to Peak Detect Function and Specified Bandwidth with Maximum Hold Mode.
6. The measurement has to be done between each power line and ground at the power terminal.

#### 4.1.4. Test Setup Layout

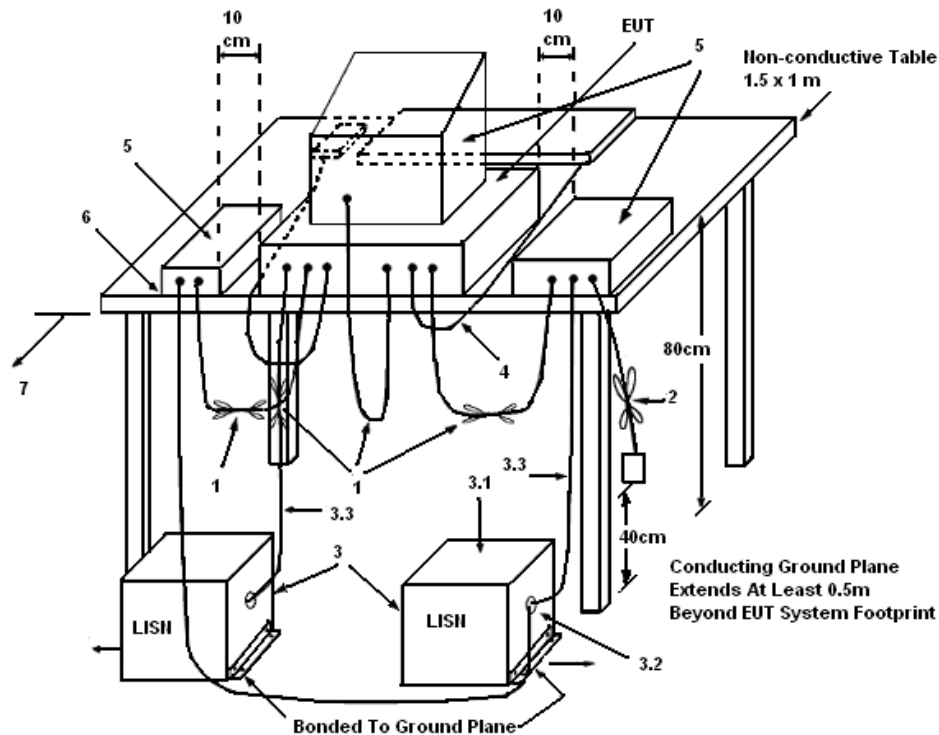

#### LEGEND:

- (1) Interconnecting cables that hang closer than 40 cm to the ground plane shall be folded back and forth in the center forming a bundle 30 to 40 cm long.
- (2) I/O cables that are not connected to a peripheral shall be bundled in the center. The end of the cable may be terminated, if required, using the correct terminating impedance. The overall length shall not exceed 1 m.
- (3) EUT connected to one LISN. Unused LISN measuring port connectors shall be terminated in 50  $\Omega$ . LISN can be placed on top of, or immediately beneath, reference ground plane.
  - (3.1) All other equipment powered from additional LISN(s).
  - (3.2) Multiple outlet strip can be used for multiple power cords of non-EUT equipment.
  - (3.3) LISN at least 80 cm from nearest part of EUT chassis.
- (4) Cables of hand-operated devices, such as keyboards, mice, etc., shall be placed as for normal use.
- (5) Non-EUT components of EUT system being tested.
- (6) Rear of EUT, including peripherals, shall all be aligned and flush with rear of tabletop.
- (7) Rear of tabletop shall be 40 cm removed from a vertical conducting plane that is bonded to the ground plane.

#### 4.1.5. Test Deviation

There is no deviation with the original standard.

#### 4.1.6. EUT Operation during Test

The EUT was placed on the test table and programmed in normal function.

4.1.7. Results of AC Power Line Conducted Emissions Measurement

Temperature	21°C	Humidity	59%
Test Engineer	Ryo Fan	Phase	Line
Configuration	Normal Link / Mode 2		

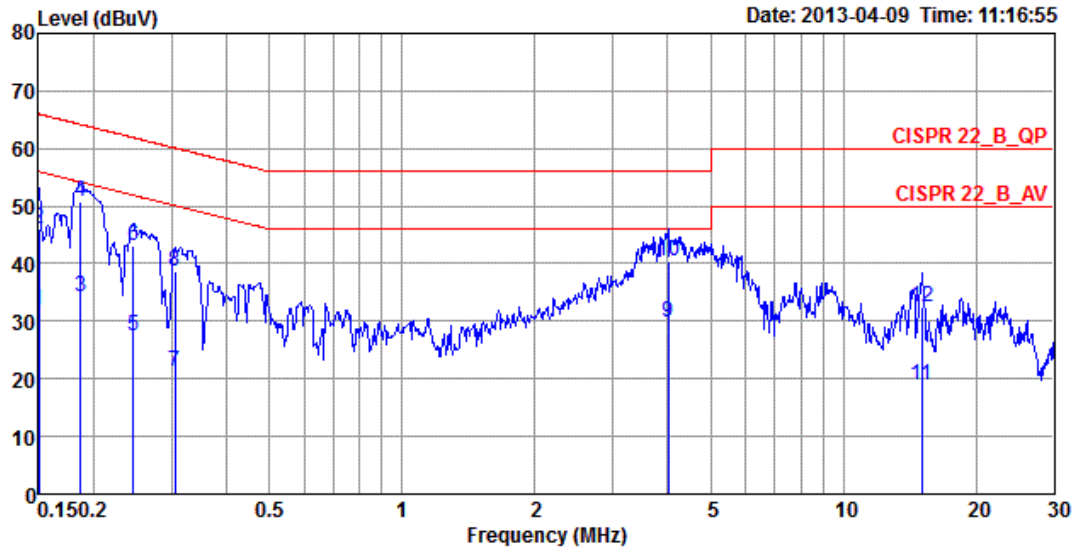

	Freq	Level	Over Limit	Limit Line	Read Level	LISN Factor	Cable Loss	Remark
	MHz	dBuV	dB	dBuV	dBuV	dB	dB	
1	0.15	31.94	-24.06	56.00	31.67	0.22	0.05	Average
2	0.15	46.10	-19.90	66.00	45.83	0.22	0.05	QP
3	0.19	34.38	-19.82	54.20	34.10	0.21	0.07	Average
4	pp	0.19	50.77	-13.43	64.20	50.49	0.21	QP
5	0.25	27.50	-24.41	51.91	27.23	0.21	0.06	Average
6	0.25	43.24	-18.67	61.91	42.97	0.21	0.06	QP
7	0.31	21.32	-28.78	50.10	21.04	0.22	0.06	Average
8	0.31	38.55	-21.55	60.10	38.27	0.22	0.06	QP
9	av	4.01	29.74	-16.26	46.00	29.32	0.29	Average
10	4.01	40.52	-15.48	56.00	40.10	0.29	0.13	QP
11	15.07	18.87	-31.13	50.00	18.15	0.61	0.11	Average
12	15.07	32.49	-27.51	60.00	31.77	0.61	0.11	QP

Temperature	21°C	Humidity	59%
Test Engineer	Ryo Fan	Phase	Neutral
Configuration	Normal Link / Mode 2		

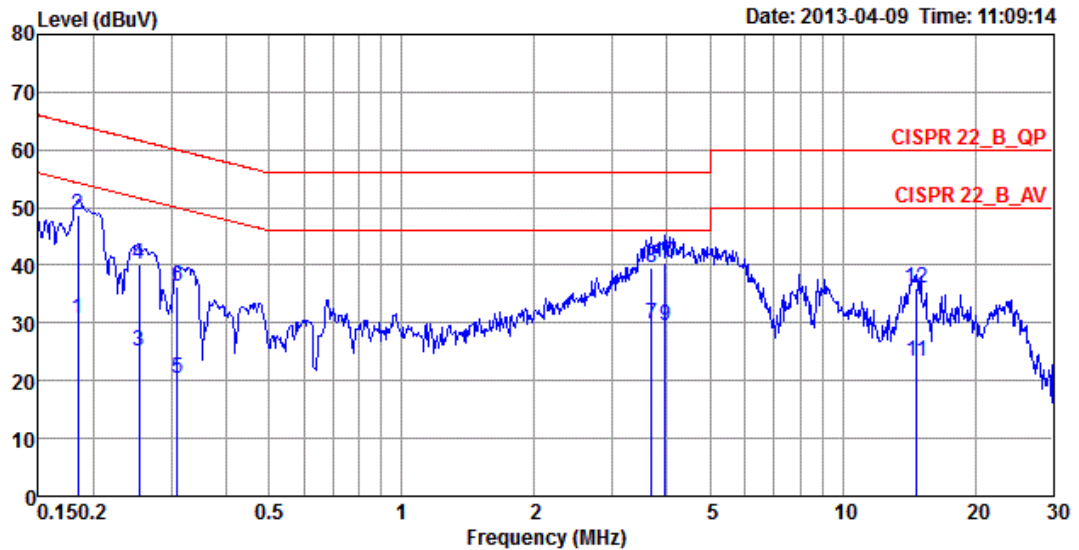

	Freq	Level	Over Limit	Limit Line	Read Level	LISN Factor	Cable Loss	Remark
	MHz	dBuV	dB	dBuV	dBuV	dB	dB	
1	0.18	30.60	-23.68	54.28	30.45	0.08	0.07	Average
2	0.18	48.69	-15.59	64.28	48.54	0.08	0.07	QP
3	0.25	25.17	-26.47	51.64	25.04	0.07	0.06	Average
4	0.25	40.29	-21.35	61.64	40.16	0.07	0.06	QP
5	0.31	20.28	-29.69	49.97	20.14	0.08	0.06	Average
6	0.31	36.32	-23.65	59.97	36.18	0.08	0.06	QP
7 av	3.68	29.75	-16.25	46.00	29.48	0.15	0.12	Average
8	3.68	39.52	-16.48	56.00	39.25	0.15	0.12	QP
9	3.96	29.62	-16.38	46.00	29.34	0.15	0.13	Average
10 pp	3.96	40.58	-15.42	56.00	40.30	0.15	0.13	QP
11	14.75	23.35	-26.65	50.00	22.84	0.40	0.11	Average
12	14.75	36.03	-23.97	60.00	35.52	0.40	0.11	QP

Note:

Level = Read Level + LISN Factor + Cable Loss.

## 4.2. 26dB Bandwidth Measurement

### 4.2.1. Limit

No restriction limits.

### 4.2.2. Measuring Instruments and Setting

Please refer to section 5 of equipments list in this report. The following table is the setting of the spectrum analyzer.

Spectrum Parameters	Setting
Attenuation	Auto
Span Frequency	> 26dB Bandwidth
RB	Approximately 1% of the emission bandwidth
VB	VBW > RBW
Detector	Peak
Trace	Max Hold
Sweep Time	Auto

### 4.2.3. Test Procedures

1. The transmitter output (antenna port) was connected to the spectrum analyzer in peak hold mode.
2. Measure the maximum width of the emission that is 26 dB down from the peak of the emission. Compare this with the RBW setting of the analyzer. Readjust RBW and repeat measurement as needed until the RBW/EBW ratio is approximately 1%.

### 4.2.4. Test Setup Layout

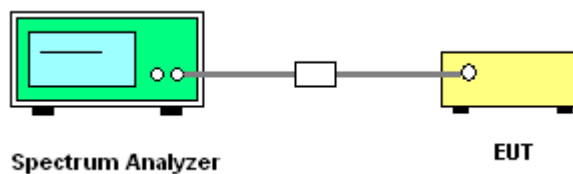

### 4.2.5. Test Deviation

There is no deviation with the original standard.

### 4.2.6. EUT Operation during Test

The EUT was programmed to be in continuously transmitting mode.

#### 4.2.7. Test Result of 26dB Bandwidth

Temperature	25°C	Humidity	56%
Test Engineer	Benson Peng	Configurations	IEEE 802.11n

##### Configuration IEEE 802.11n MCS0 20MHz / Chain 1 + Chain 2 + Chain 3

Channel	Frequency	26dB Bandwidth (MHz)	99% Occupied Bandwidth (MHz)
36	5180 MHz	19.84	17.60
40	5200 MHz	19.84	17.44
48	5240 MHz	20.00	17.60
52	5260 MHz	36.00	19.68
60	5300 MHz	35.52	20.32
64	5320 MHz	30.88	18.56
100	5500 MHz	23.04	17.92
116	5580 MHz	35.68	18.88
140	5700 MHz	30.24	17.92

##### Configuration IEEE 802.11n MCS0 40MHz / Chain 1 + Chain 2 + Chain 3

Channel	Frequency	26dB Bandwidth (MHz)	99% Occupied Bandwidth (MHz)
38	5190 MHz	38.40	35.84
46	5230 MHz	38.72	35.52
54	5270 MHz	66.24	40.32
62	5310 MHz	38.72	35.84
102	5510MHz	39.36	36.80
110	5550 MHz	79.04	43.84
134	5670 MHz	70.40	36.80

<b>Temperature</b>	25°C	<b>Humidity</b>	56%
<b>Test Engineer</b>	Benson Peng	<b>Configurations</b>	IEEE 802.11a

**Configuration IEEE 802.11a / Chain 1**

Channel	Frequency	26dB Bandwidth (MHz)	99% Occupied Bandwidth (MHz)
36	5180 MHz	28.32	17.44
40	5200 MHz	28.32	17.44
48	5240 MHz	28.80	17.60
52	5260 MHz	53.76	37.92
60	5300 MHz	41.28	24.96
64	5320 MHz	33.44	18.72
100	5500 MHz	32.00	18.08
116	5580 MHz	44.96	29.76
140	5700 MHz	30.40	17.44



**26 dB Bandwidth Plot on Configuration IEEE 802.11n MCS0 20MHz / Chain 1 + Chain 2 + Chain 3 / 5180 MHz**

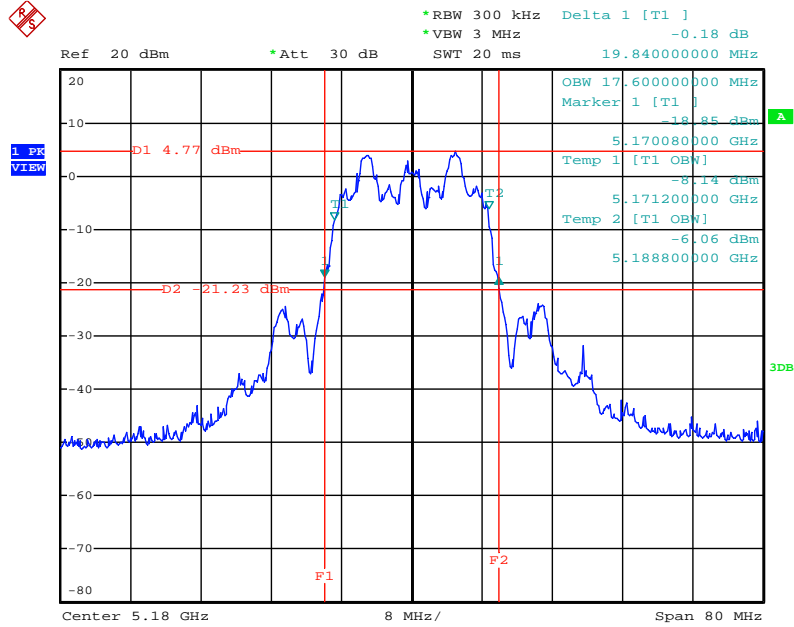

Date: 26.MAR.2013 15:21:23

**26 dB Bandwidth Plot on Configuration IEEE 802.11n MCS0 20MHz / Chain 1 + Chain 2 + Chain 3 / 5200 MHz**

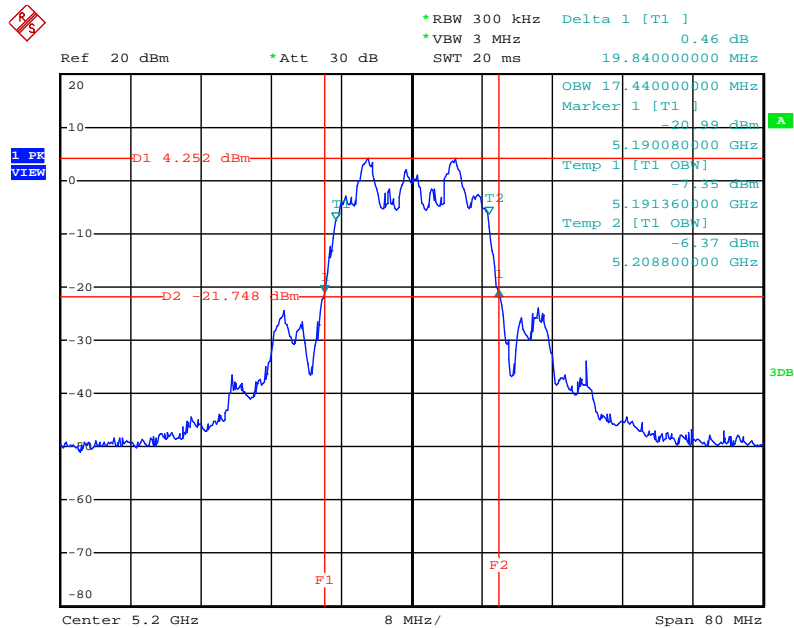

Date: 26.MAR.2013 15:21:52

**26 dB Bandwidth Plot on Configuration IEEE 802.11n MCS0 20MHz / Chain 1 + Chain 2 + Chain 3 / 5240 MHz**

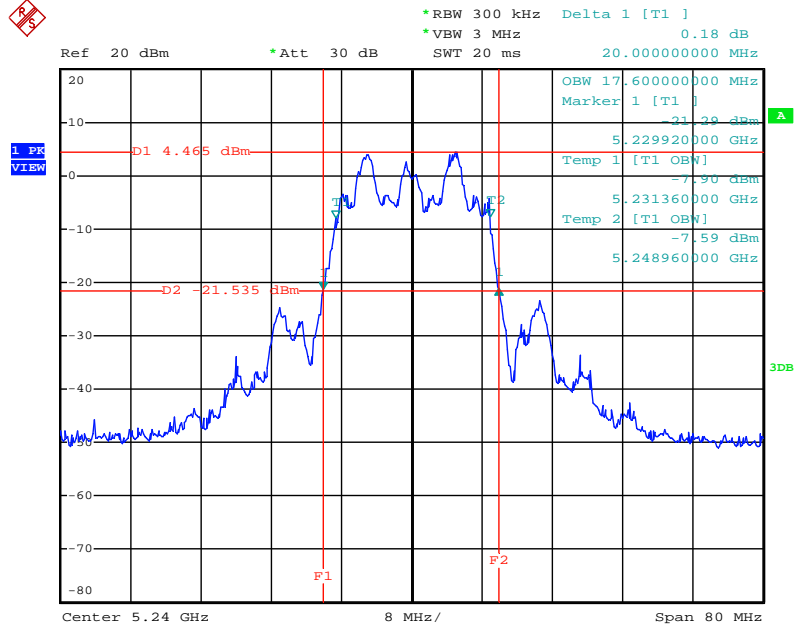

Date: 26.MAR.2013 15:22:28

**26 dB Bandwidth Plot on Configuration IEEE 802.11n MCS0 20MHz / Chain 1 + Chain 2 + Chain 3 / 5260 MHz**

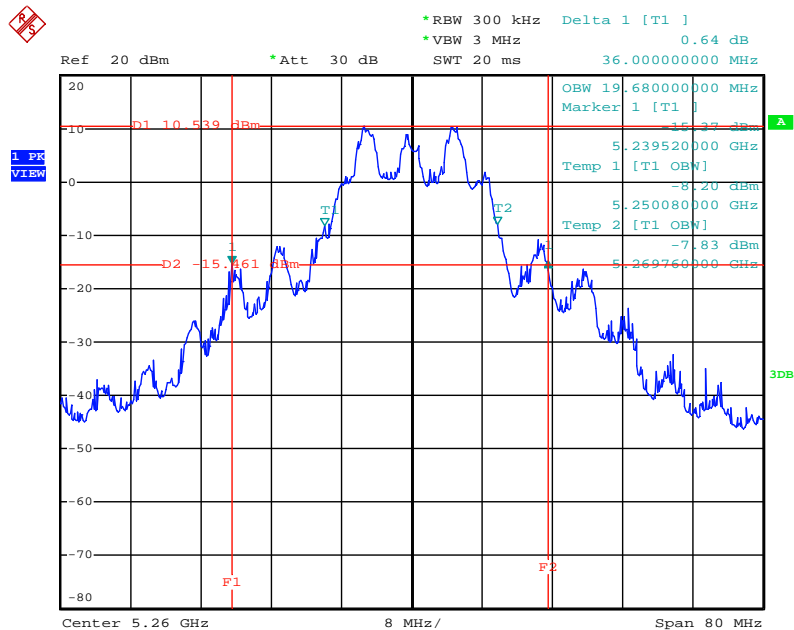

Date: 26.MAR.2013 15:24:57

**26 dB Bandwidth Plot on Configuration IEEE 802.11n MCS0 20MHz / Chain 1 + Chain 2 + Chain 3 / 5300 MHz**

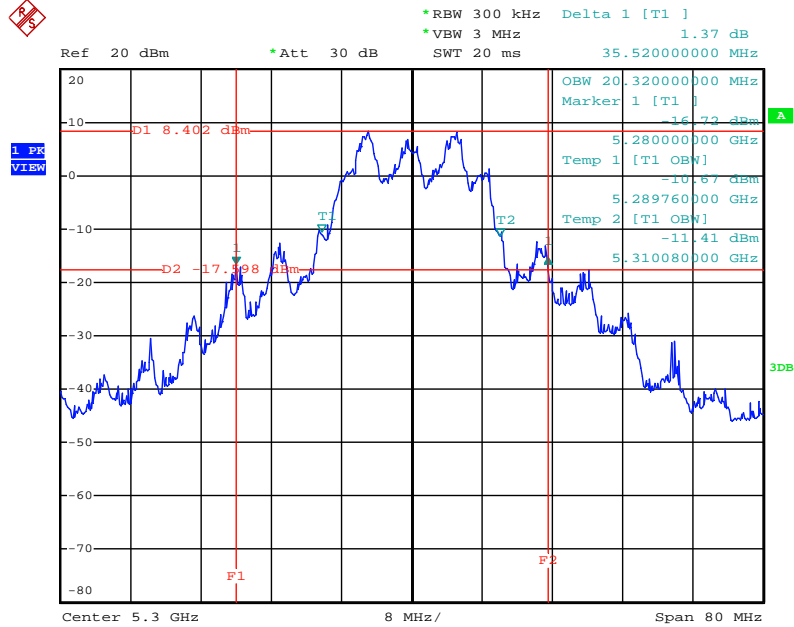

Date: 26.MAR.2013 15:24:16

**26 dB Bandwidth Plot on Configuration IEEE 802.11n MCS0 20MHz / Chain 1 + Chain 2 + Chain 3 / 5320 MHz**

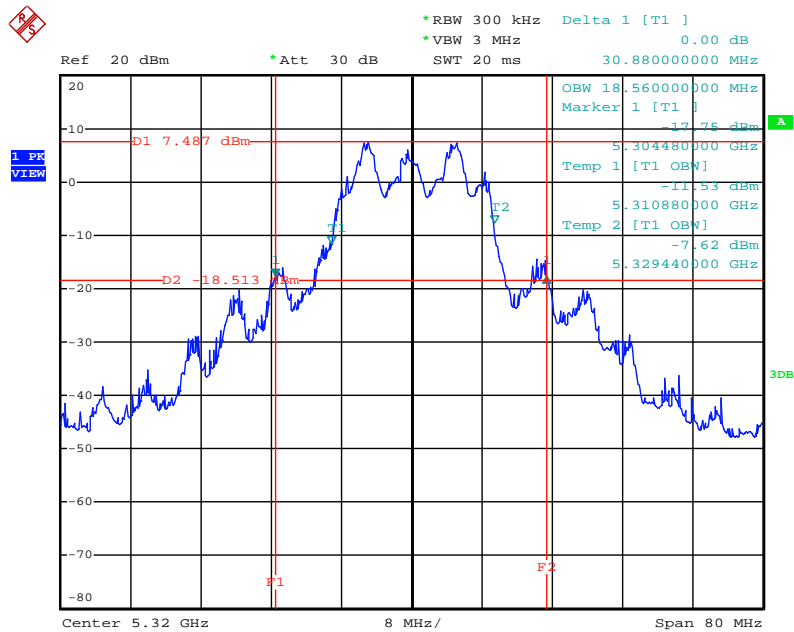

Date: 26.MAR.2013 15:25:24

26 dB Bandwidth Plot on Configuration IEEE 802.11n MCS0 20MHz / Chain 1 + Chain 2 + Chain 3 / 5500 MHz

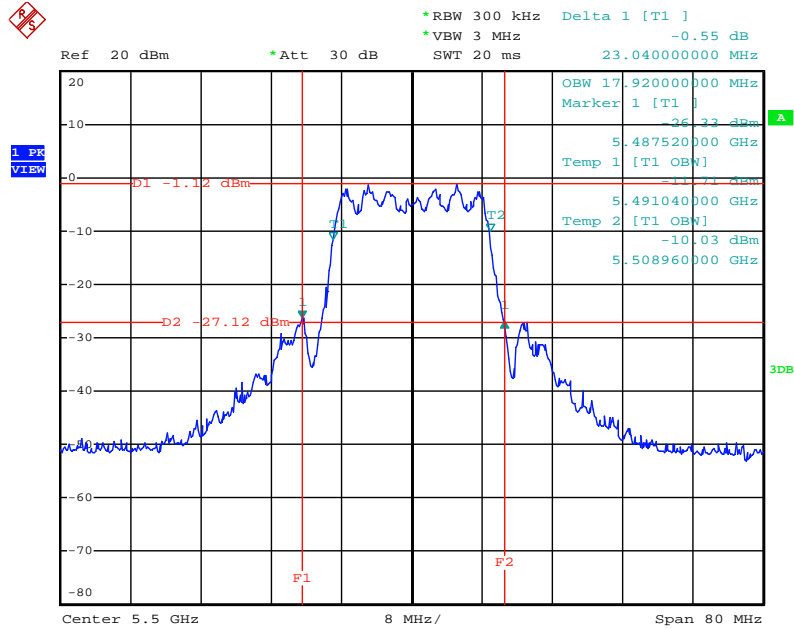

Date: 26.MAR.2013 15:25:54

26 dB Bandwidth Plot on Configuration IEEE 802.11n MCS0 20MHz / Chain 1 + Chain 2 + Chain 3 / 5580 MHz

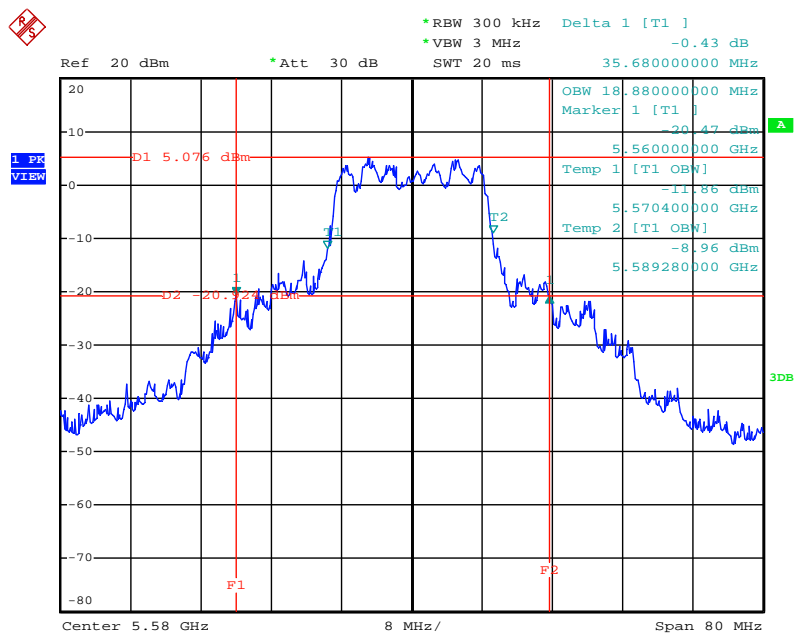

Date: 26.MAR.2013 15:27:07

**26 dB Bandwidth Plot on Configuration IEEE 802.11n MCS0 20MHz / Chain 1 + Chain 2 + Chain 3 / 5700 MHz**

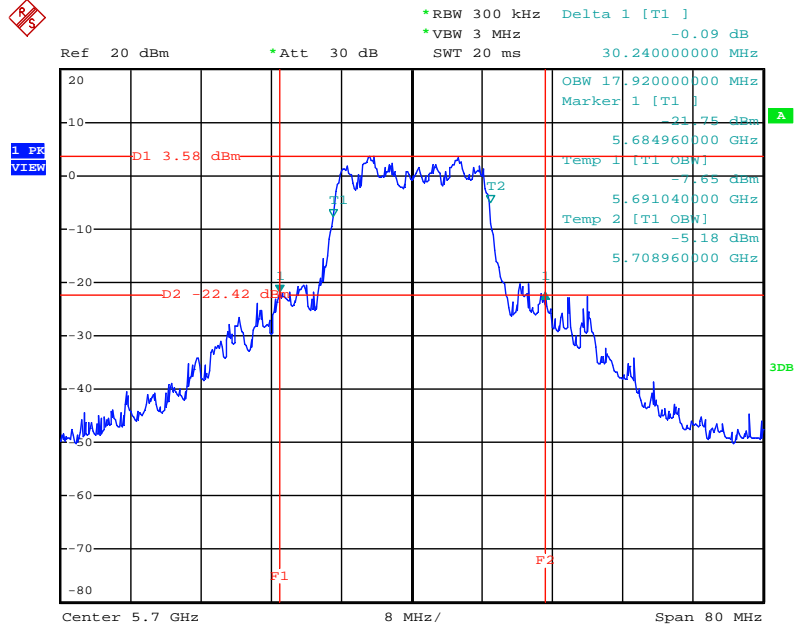

Date: 26.MAR.2013 15:27:45

**26 dB Bandwidth Plot on Configuration IEEE 802.11n MCS0 40MHz / Chain 1 + Chain 2 + Chain 3 / 5190 MHz**

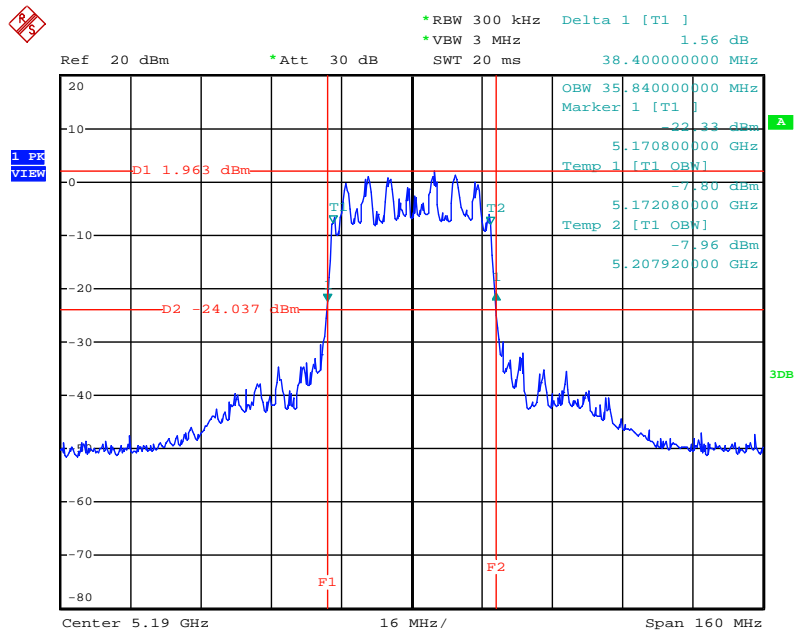

Date: 26.MAR.2013 15:29:34

**26 dB Bandwidth Plot on Configuration IEEE 802.11n MCS0 40MHz / Chain 1 + Chain 2 + Chain 3 / 5230 MHz**

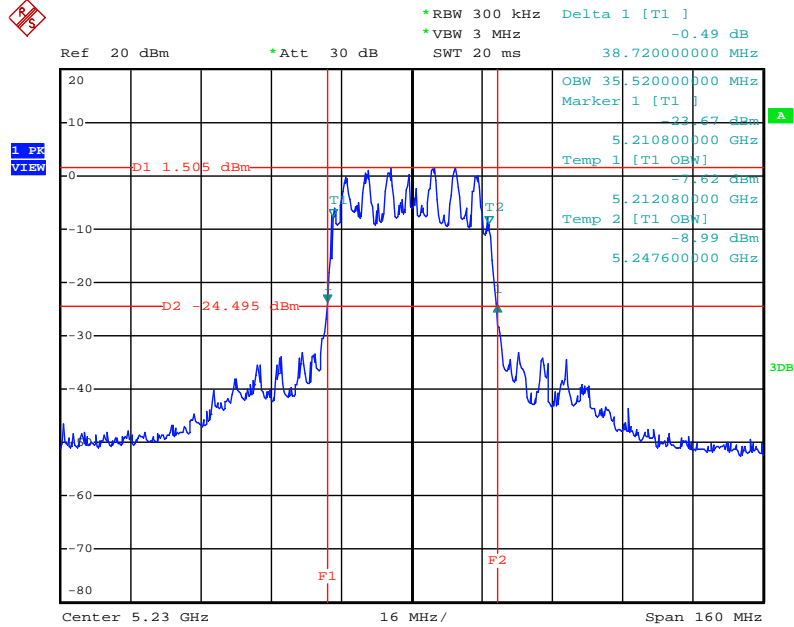

Date: 26.MAR.2013 15:30:02

**26 dB Bandwidth Plot on Configuration IEEE 802.11n MCS0 40MHz / Chain 1 + Chain 2 + Chain 3 / 5270 MHz**

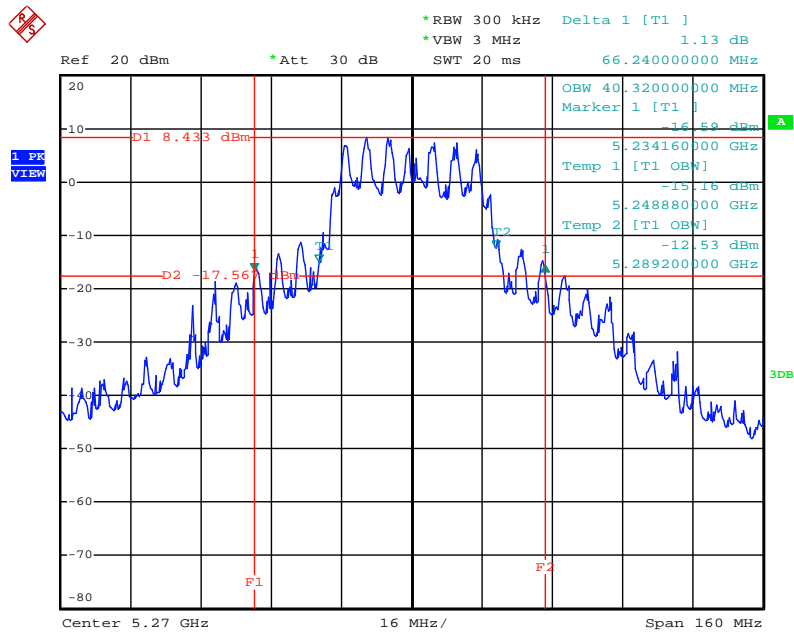

Date: 26.MAR.2013 15:30:49

**26 dB Bandwidth Plot on Configuration IEEE 802.11n MCS0 40MHz / Chain 1 + Chain 2 + Chain 3 / 5310 MHz**

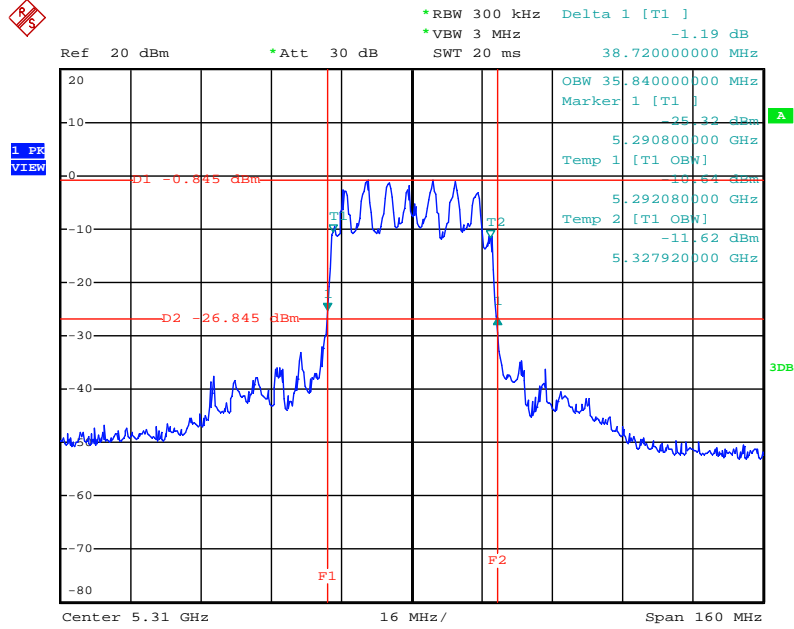

Date: 26.MAR.2013 15:31:19

**26 dB Bandwidth Plot on Configuration IEEE 802.11n MCS0 40MHz / Chain 1 + Chain 2 + Chain 3 / 5510MHz**

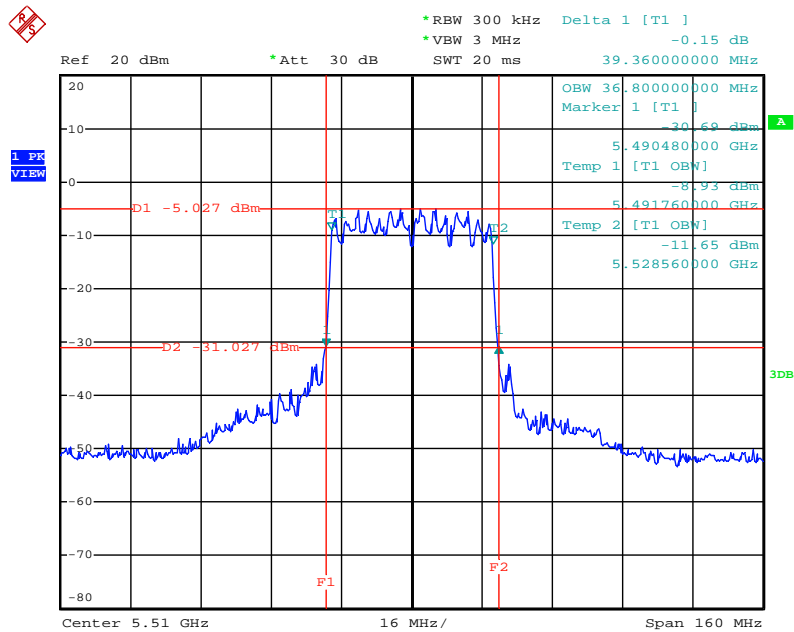

Date: 26.MAR.2013 15:31:48

**26 dB Bandwidth Plot on Configuration IEEE 802.11n MCS0 40MHz / Chain 1 + Chain 2 + Chain 3 / 5550 MHz**

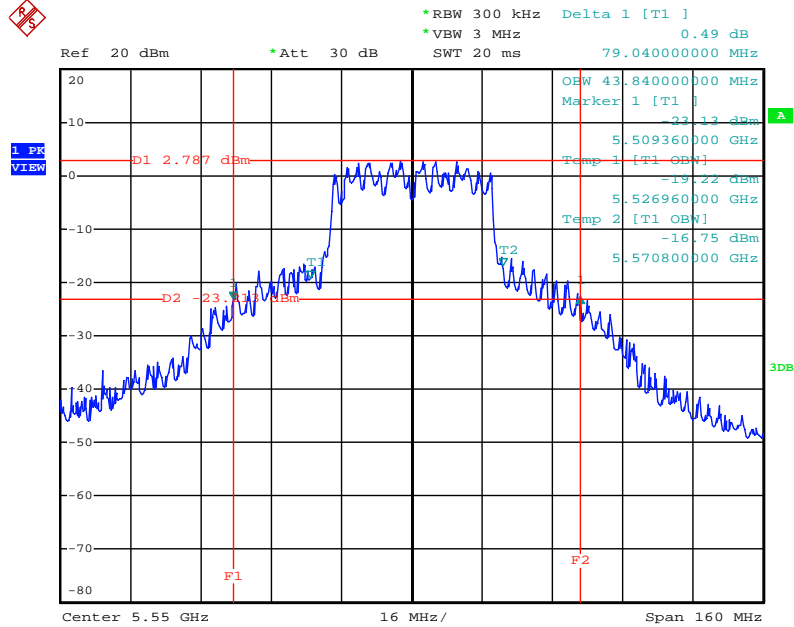

Date: 26.MAR.2013 15:34:21

**26 dB Bandwidth Plot on Configuration IEEE 802.11n MCS0 40MHz / Chain 1 + Chain 2 + Chain 3 / 5670 MHz**

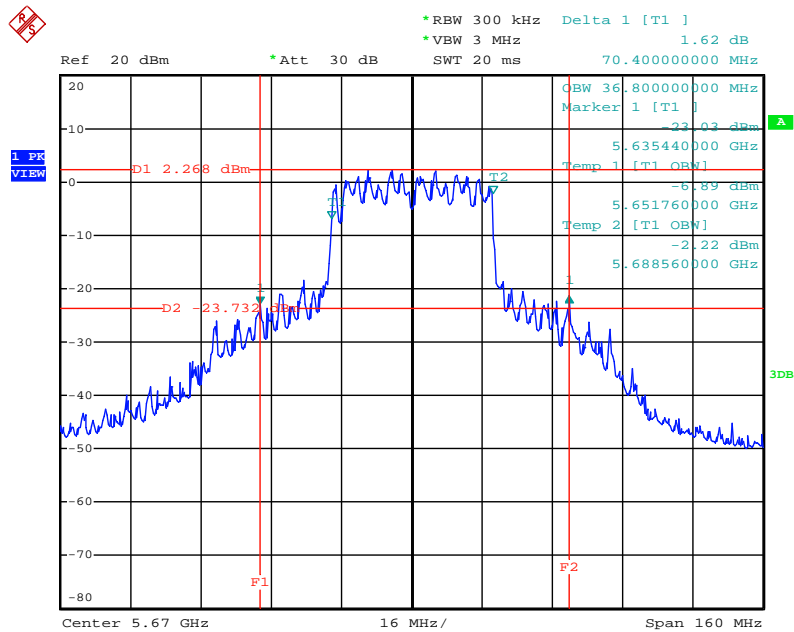

Date: 26.MAR.2013 15:34:48



### 26 dB Bandwidth Plot on Configuration IEEE 802.11a / Chain 1 / 5180 MHz

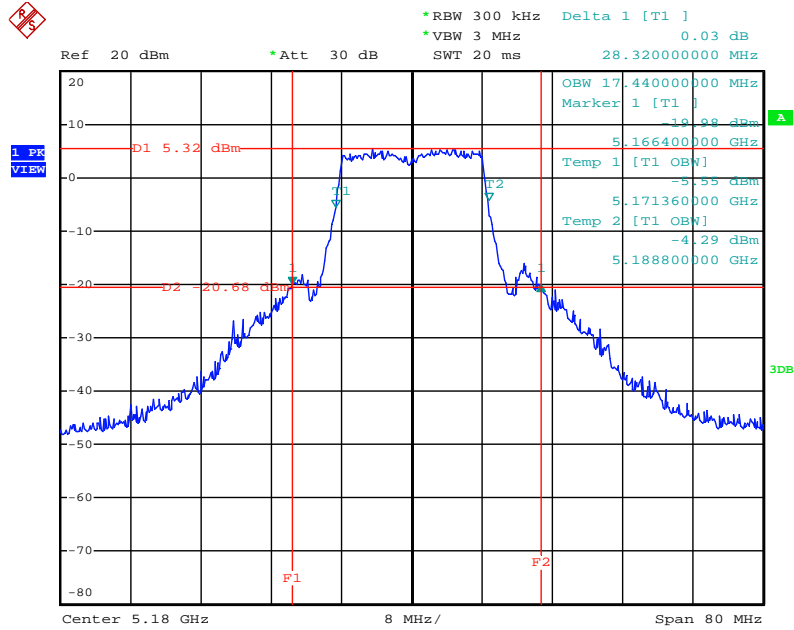

Date: 26.MAR.2013 15:36:03

### 26 dB Bandwidth Plot on Configuration IEEE 802.11a / Chain 1 / 5200 MHz

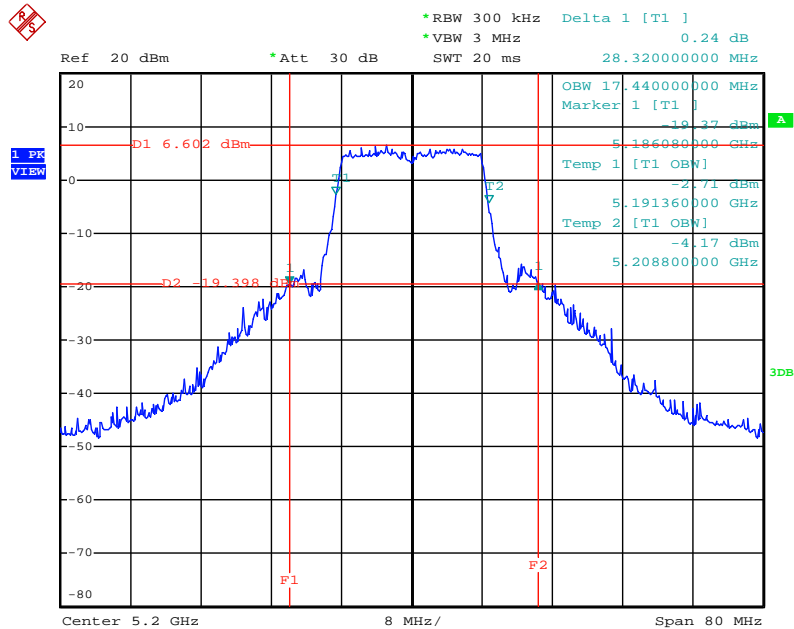

Date: 26.MAR.2013 15:36:35

26 dB Bandwidth Plot on Configuration IEEE 802.11a / Chain 1 / 5240 MHz

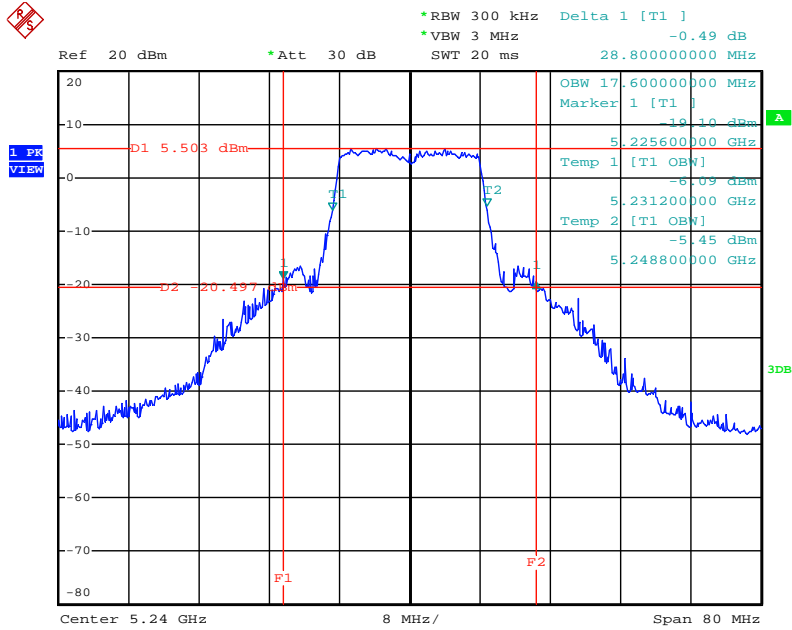

Date: 26.MAR.2013 15:36:56

26 dB Bandwidth Plot on Configuration IEEE 802.11a / Chain 1 / 5260 MHz

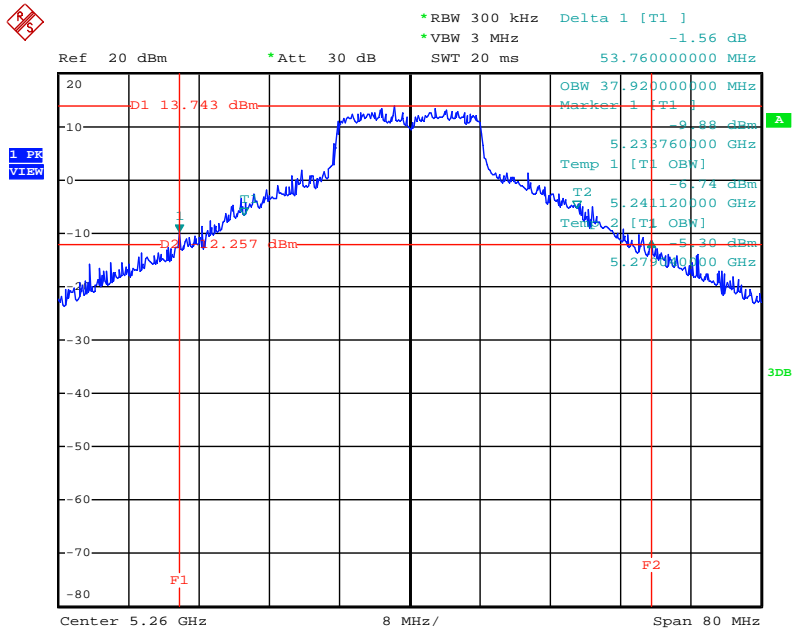

Date: 26.MAR.2013 15:37:23

26 dB Bandwidth Plot on Configuration IEEE 802.11a / Chain 1 / 5300 MHz

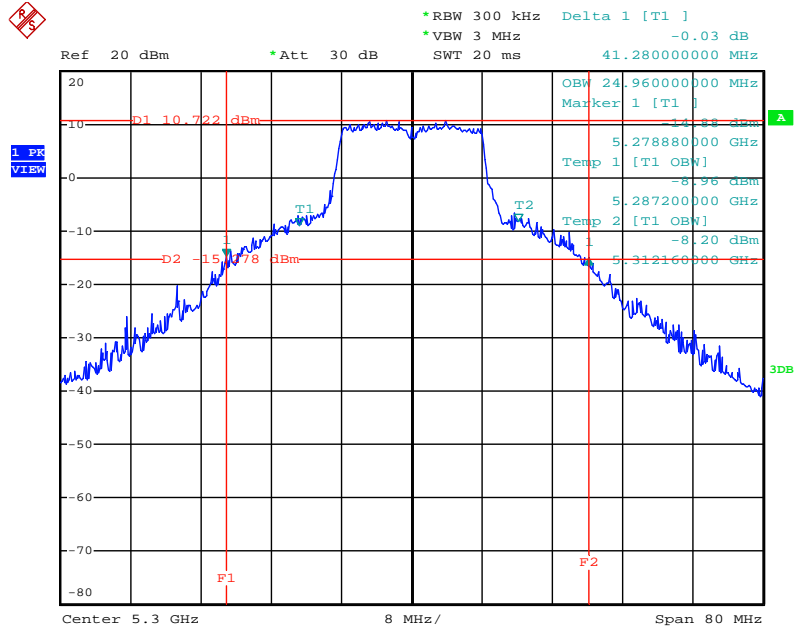

Date: 26.MAR.2013 15:38:00

26 dB Bandwidth Plot on Configuration IEEE 802.11a / Chain 1 / 5320 MHz

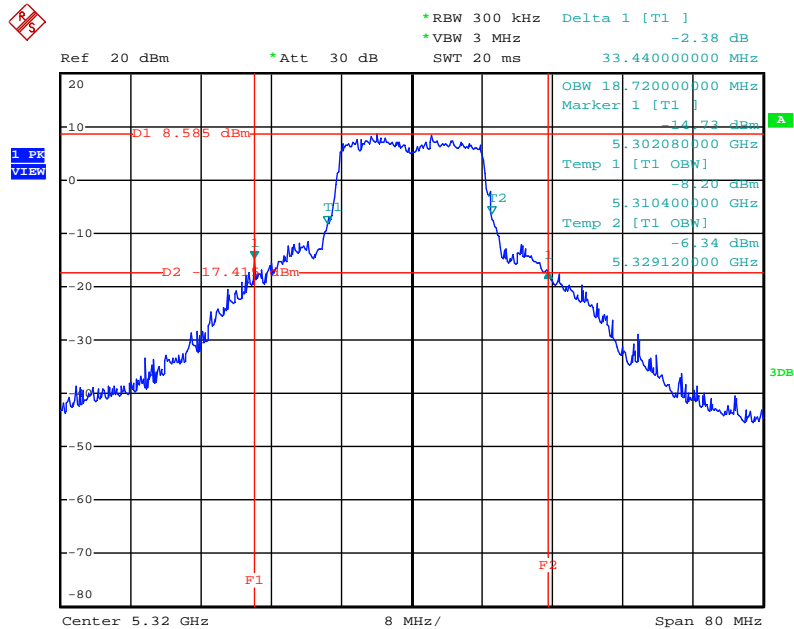

Date: 26.MAR.2013 15:38:24

26 dB Bandwidth Plot on Configuration IEEE 802.11a / Chain 1 / 5500 MHz

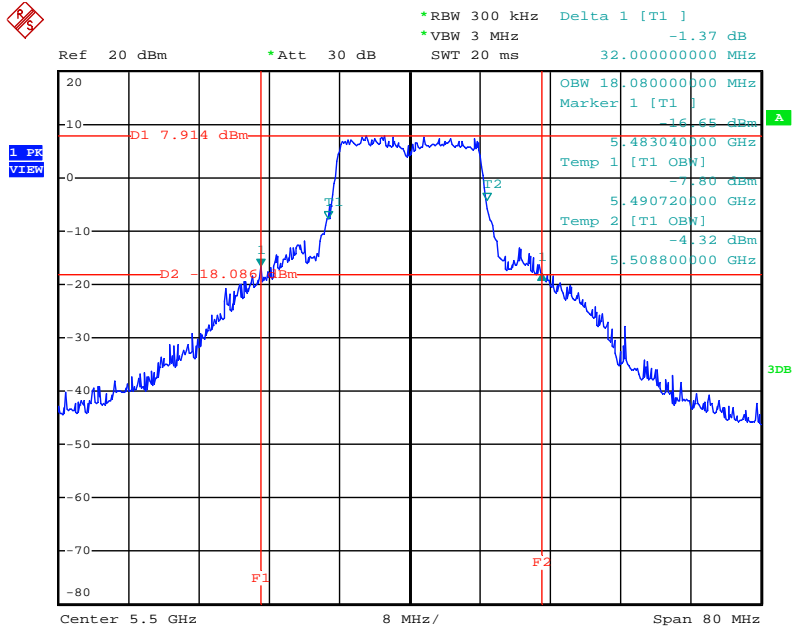

Date: 26.MAR.2013 15:38:51

26 dB Bandwidth Plot on Configuration IEEE 802.11a / Chain 1 / 5580 MHz

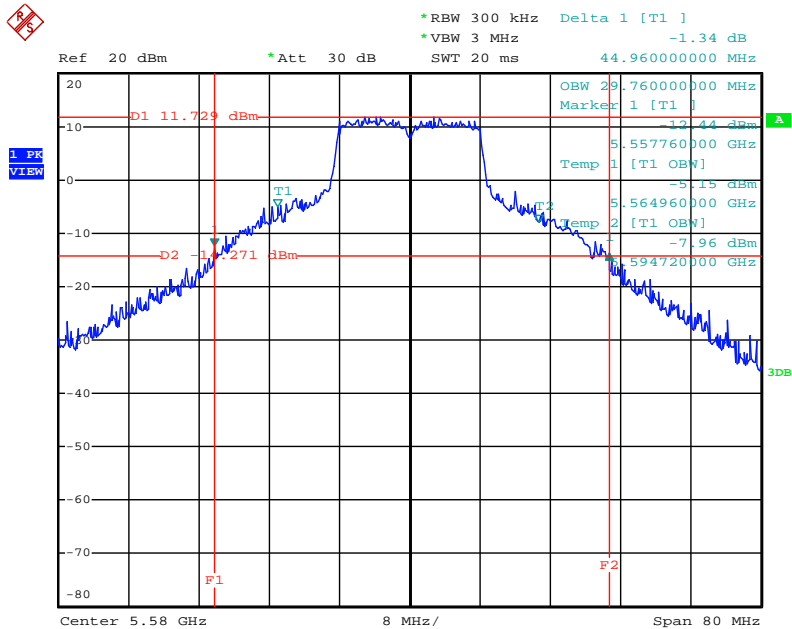

Date: 26.MAR.2013 15:39:20

26 dB Bandwidth Plot on Configuration IEEE 802.11a / Chain 1 / 5700 MHz

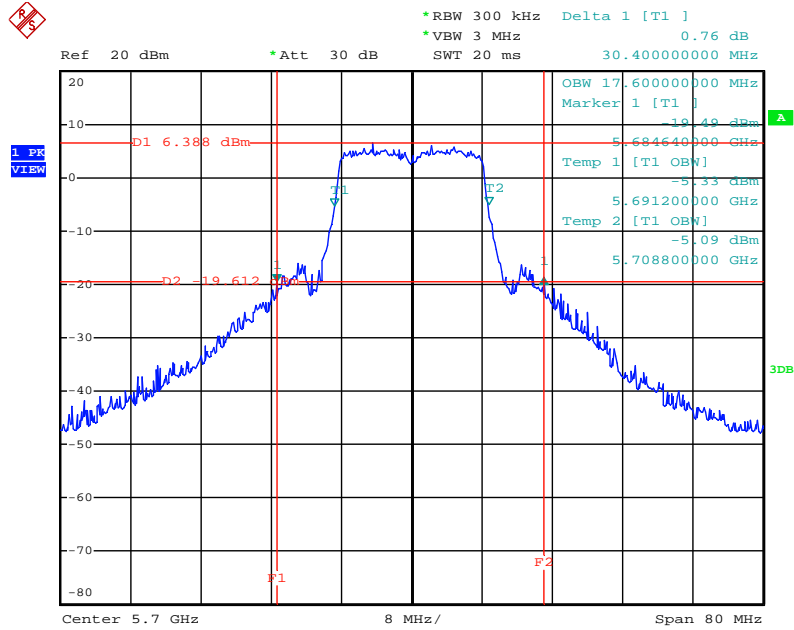

Date: 26.MAR.2013 15:39:46

### 4.3. Maximum Conducted Output Power Measurement

#### 4.3.1. Limit

For the band 5.15~5.25 GHz, the maximum conducted output power over the frequency band of operation shall not exceed the lesser of 50 mW (17dBm) or  $4 \text{ dBm} + 10\log B$ , where B is the 26 dB emissions bandwidth in MHz. If transmitting antennas of directional gain greater than 6 dBi are used, both the maximum conducted output power and the peak power spectral density shall be reduced by the amount in dB that the directional gain of the antenna exceeds 6 dBi.

For the 5.25-5.35 GHz and 5.470-5.725 GHz bands, the maximum conducted output power over the frequency bands of operation shall not exceed the lesser of 250 mW (24dBm) or  $11 \text{ dBm} + 10\log B$ , where B is the 26-dB emission bandwidth in MHz. If transmitting antennas of directional gain greater than 6 dBi are used, both the maximum conducted output power and the peak power spectral density shall be reduced by the amount in dB that the directional gain of the antenna exceeds 6 dBi.

#### 4.3.2. Measuring Instruments and Setting

The following table is the setting of the peak power meter.

Power Meter Parameter	Setting
Bandwidth	50MHz bandwidth is greater than the EUT emission bandwidth
Detector	AVERAGE

#### 4.3.3. Test Procedures

1. The transmitter output (antenna port) was connected to the power meter.
2. Test was performed in accordance with KDB 789033 Guidelines for Compliance Testing of Unlicensed National Information Infrastructure (U-NII) Devices - Part 15, Subpart E, section (C) Maximum conducted output power =>(4) Method PM (Measurement using an RF average power meter) Multiple antenna systems was performed in accordance with KDB 662911 Emissions Testing of Transmitters with Multiple Outputs in the Same Band.
3. When measuring maximum conducted output power with multiple antenna systems, add every result of the values by mathematic formula.

#### 4.3.4. Test Setup Layout

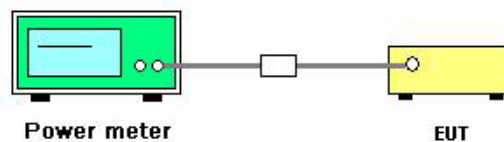

#### 4.3.5. Test Deviation

There is no deviation with the original standard.

#### 4.3.6. EUT Operation during Test

The EUT was programmed to be in continuously transmitting mode.

#### 4.3.7. Test Result of Maximum Conducted Output Power

Temperature	25°C	Humidity	56%
Test Engineer	Benson Peng	Configurations	IEEE 802.11n
Test Date	Mar. 26, 2013		

##### Configuration IEEE 802.11n MCS0 20MHz / Chain 1 + Chain 2 + Chain 3

Channel	Frequency	Conducted Power (dBm)			Total Conducted Output Power (dBm)	Max. Limit (dBm)	Result
		Chain 1	Chain 2	Chain 3			
36	5180 MHz	10.20	11.45	11.15	15.74	16.98	Complies
40	5200 MHz	10.08	11.19	11.40	15.70	16.98	Complies
48	5240 MHz	9.73	11.22	10.86	15.42	17.00	Complies
52	5260 MHz	17.10	18.25	18.00	22.58	24.00	Complies
60	5300 MHz	17.01	18.07	17.99	22.49	24.00	Complies
64	5320 MHz	16.18	17.17	17.14	21.62	24.00	Complies
100	5500 MHz	10.94	10.76	11.67	15.91	24.00	Complies
116	5580 MHz	16.71	16.93	17.30	21.76	24.00	Complies
140	5700 MHz	15.30	15.35	15.56	20.18	24.00	Complies

Note: 17dBm or 4 dBm + 10log B, where B is the 26-dB emission bandwidth, so ch 36 and ch40 power limit= 16.98dBm

##### Configuration IEEE 802.11n MCS0 40MHz / Chain 1 + Chain 2 + Chain 3

Channel	Frequency	Conducted Power (dBm)			Total Conducted Output Power (dBm)	Max. Limit (dBm)	Result
		Chain 1	Chain 2	Chain 3			
38	5190 MHz	11.66	12.05	12.22	16.75	17.00	Complies
46	5230 MHz	11.66	11.80	11.90	16.56	17.00	Complies
54	5270 MHz	19.00	18.96	18.90	23.72	24.00	Complies
62	5310 MHz	11.12	11.55	10.80	15.94	24.00	Complies
102	5510MHz	10.32	11.21	10.56	15.48	24.00	Complies
110	5550 MHz	18.50	18.64	18.54	23.33	24.00	Complies
134	5670 MHz	17.42	17.10	17.30	22.05	24.00	Complies



<b>Temperature</b>	25°C	<b>Humidity</b>	56%
<b>Test Engineer</b>	Benson Peng	<b>Configurations</b>	IEEE 802.11a
<b>Test Date</b>	Mar. 26, 2013		

**Configuration IEEE 802.11a / Chain 1**

<b>Channel</b>	<b>Frequency</b>	<b>Conducted Power (dBm)</b>	<b>Max. Limit (dBm)</b>	<b>Result</b>
36	5180 MHz	16.85	17.00	<b>Complies</b>
40	5200 MHz	16.87	17.00	<b>Complies</b>
48	5240 MHz	16.89	17.00	<b>Complies</b>
52	5260 MHz	22.91	24.00	<b>Complies</b>
60	5300 MHz	20.94	24.00	<b>Complies</b>
64	5320 MHz	18.66	24.00	<b>Complies</b>
100	5500 MHz	18.48	24.00	<b>Complies</b>
116	5580 MHz	21.42	24.00	<b>Complies</b>
140	5700 MHz	17.16	24.00	<b>Complies</b>

## 4.4. Power Spectral Density Measurement

### 4.4.1. Limit

The power spectral density is defined as the highest level of power in dBm per MHz generated by the transmitter within the power envelope. The following table is power spectral density limits and decrease power density limit rule refer to section 4.3.1.

Frequency Range	Power Spectral Density limit (dBm/MHz)
5.15~5.25 GHz	4
5.25-5.35 GHz	11
5470-5725	11

### 4.4.2. Measuring Instruments and Setting

Please refer to section 5 of equipments list in this report. The following table is the setting of the spectrum analyzer.

Spectrum Parameter	Setting
Attenuation	Auto
Span Frequency	Encompass the entire emissions bandwidth (EBW) of the signal
RB	1000 kHz
VB	3000 kHz
Detector	RMS
Trace	AVERAGE
Sweep Time	Auto
Trace Average	100 times

### 4.4.3. Test Procedures

1. The transmitter output (antenna port) was connected RF switch to the spectrum analyzer.
2. Test was performed in accordance with KDB 789033 Guidelines for Compliance Testing of Unlicensed National Information Infrastructure (U-NII) Devices - Part 15, Subpart E, section (C) Maximum conducted output power => (d) Method SA-2 (trace averaging across on and off times of the EUT transmissions, followed by duty cycle correction).
3. Multiple antenna systems was performed in accordance with KDB 662911 in-Band Power Spectral Density (PSD) Measurements (1) Measure and sum the spectra across the outputs.
4. When measuring first spectral bin of output 1 is summed with that in the first spectral bin of output 2 and that from the first spectral bin of output 3 and so on up to the Nth output to obtain the value for the first frequency bin of the summed spectrum. The summed spectrum value for each of the other frequency bins is computed in the same way.

#### 4.4.4. Test Setup Layout

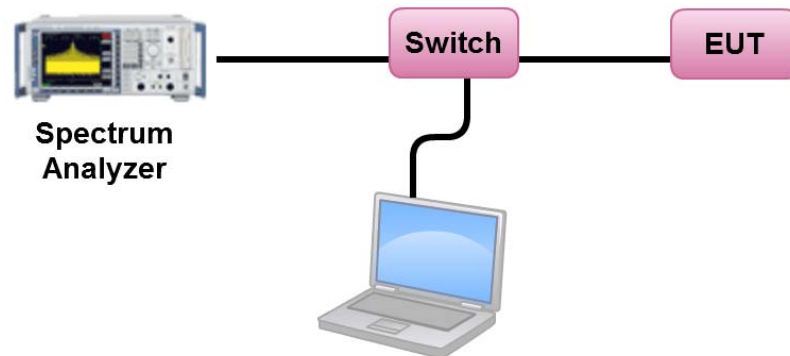

#### 4.4.5. Test Deviation

There is no deviation with the original standard.

#### 4.4.6. EUT Operation during Test

The EUT was programmed to be in continuously transmitting mode.

#### 4.4.7. Test Result of Power Spectral Density

Temperature	25°C	Humidity	56%
Test Engineer	Benson Peng	Configurations	IEEE 802.11n
Test Date	Mar. 26, 2013		

##### Configuration IEEE 802.11n MCS0 20MHz / Chain 1 + Chain 2 + Chain 3

Channel	Frequency	Total Power Density (dBm/MHz)	Max. Limit (dBm/MHz)	Result
36	5180 MHz	2.35	2.46	Complies
40	5200 MHz	2.34	2.46	Complies
48	5240 MHz	2.35	2.46	Complies
52	5260 MHz	9.29	9.46	Complies
60	5300 MHz	9.14	9.46	Complies
64	5320 MHz	8.21	9.46	Complies
100	5500 MHz	2.59	9.46	Complies
116	5580 MHz	9.29	9.46	Complies
140	5700 MHz	6.06	9.46	Complies

Note: Directional gain =  $G_{ANT} + 10 \log(N_{ANT}/N_{SS}) = 7.54 \text{ dBi} > 6 \text{ dBi}$ , So Band 1 Limit =  $4 - (7.54 - 6) = 2.46 \text{ dBm/MHz}$

Note: Directional gain =  $G_{ANT} + 10 \log(N_{ANT}/N_{SS}) = 7.54 \text{ dBi} > 6 \text{ dBi}$ , So Band 2~Band 3 Limit =  $11 - (7.54 - 6) = 9.46 \text{ dBm/MHz}$

##### Configuration IEEE 802.11n MCS0 40MHz / Chain 1 + Chain 2 + Chain 3

Channel	Frequency	Total Power Density (dBm/MHz)	Max. Limit (dBm/MHz)	Result
38	5190 MHz	0.39	2.46	Complies
46	5230 MHz	1.23	2.46	Complies
54	5270 MHz	8.71	9.46	Complies
62	5310 MHz	1.28	9.46	Complies
102	5510 MHz	1.09	9.46	Complies
110	5550 MHz	8.74	9.46	Complies
134	5670 MHz	6.78	9.46	Complies

Note: Directional gain =  $G_{ANT} + 10 \log(N_{ANT}/N_{SS}) = 7.54 \text{ dBi} > 6 \text{ dBi}$ , So Band 1 Limit =  $4 - (7.54 - 6) = 2.46 \text{ dBm/MHz}$

Note: Directional gain =  $G_{ANT} + 10 \log(N_{ANT}/N_{SS}) = 7.54 \text{ dBi} > 6 \text{ dBi}$ , So Band 2~Band 3 Limit =  $11 - (7.54 - 6) = 9.46 \text{ dBm/MHz}$

<b>Temperature</b>	25°C	<b>Humidity</b>	56%
<b>Test Engineer</b>	Benson Peng	<b>Configurations</b>	IEEE 802.11a
<b>Test Date</b>	Mar. 26, 2013		

**Configuration IEEE 802.11a / Chain 1**

Channel	Frequency	Total Power Density (dBm/MHz)	Max. Limit (dBm/MHz)	Result
36	5180 MHz	2.37	4.00	Complies
40	5200 MHz	2.53	4.00	Complies
48	5240 MHz	2.75	4.00	Complies
52	5260 MHz	9.78	11.00	Complies
60	5300 MHz	6.90	11.00	Complies
64	5320 MHz	4.40	11.00	Complies
100	5500 MHz	3.84	11.00	Complies
116	5580 MHz	8.46	11.00	Complies
140	5700 MHz	2.11	11.00	Complies

Note: All the test values were listed in the report.

For plots, only the channel with maximum results was shown.

Power Density Plot on Configuration IEEE 802.11n MCS0 20MHz / Chain 1 + Chain 2 + Chain 3  
/ 5180 MHz

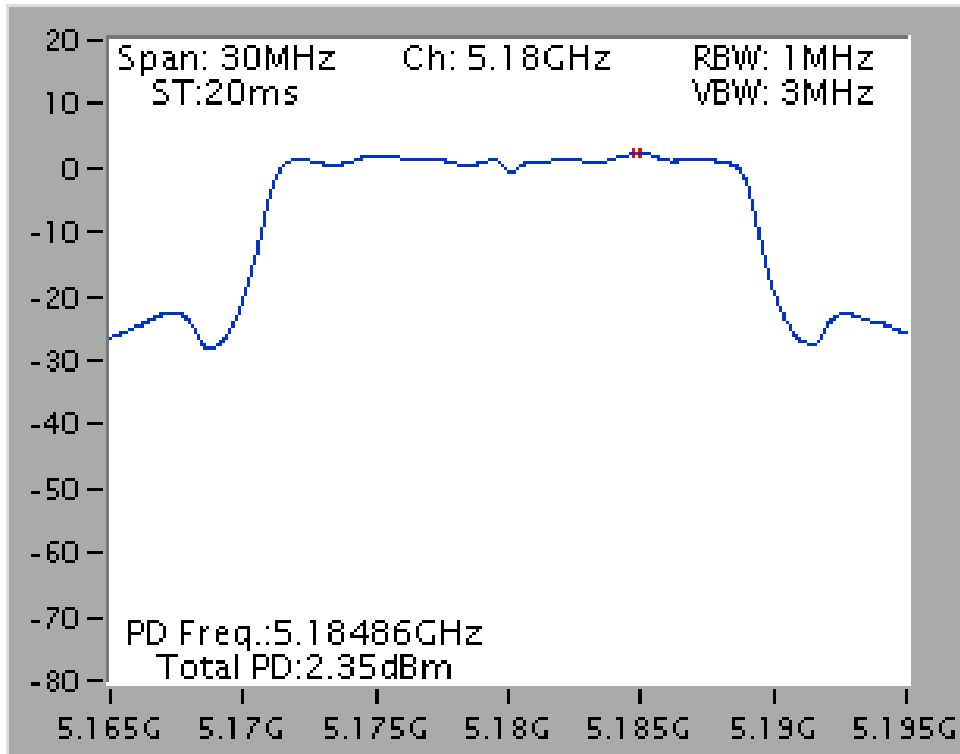

Power Density Plot on Configuration IEEE 802.11n MCS0 20MHz / Chain 1 + Chain 2 + Chain 3  
/ 5260 MHz

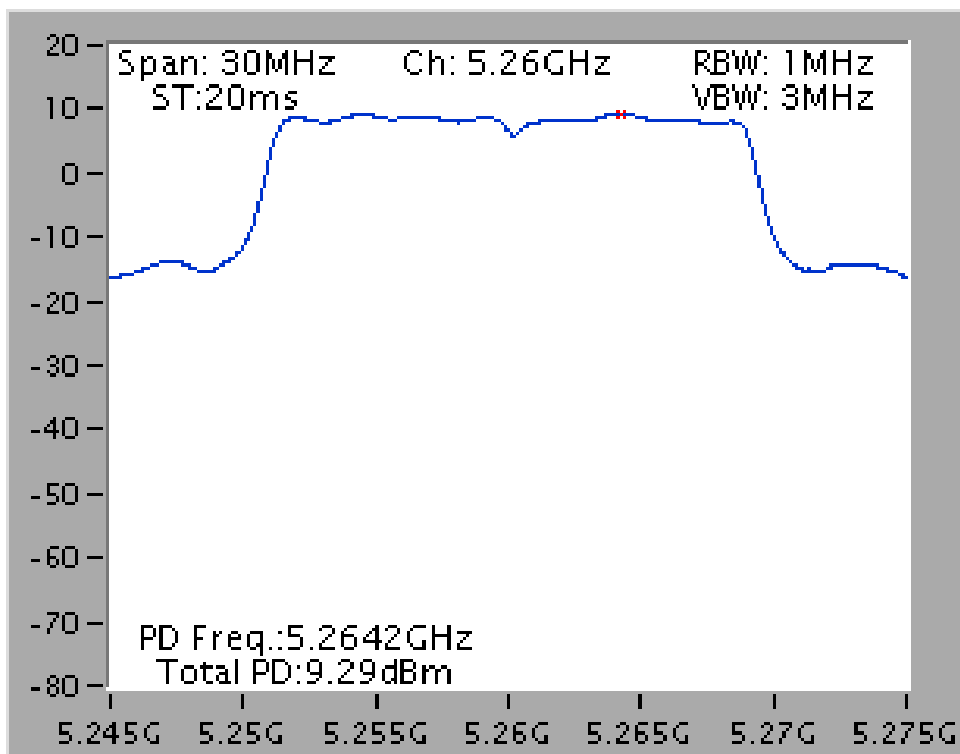

Power Density Plot on Configuration IEEE 802.11n MCS0 20MHz / Chain 1 + Chain 2 + Chain 3  
/ 5580 MHz

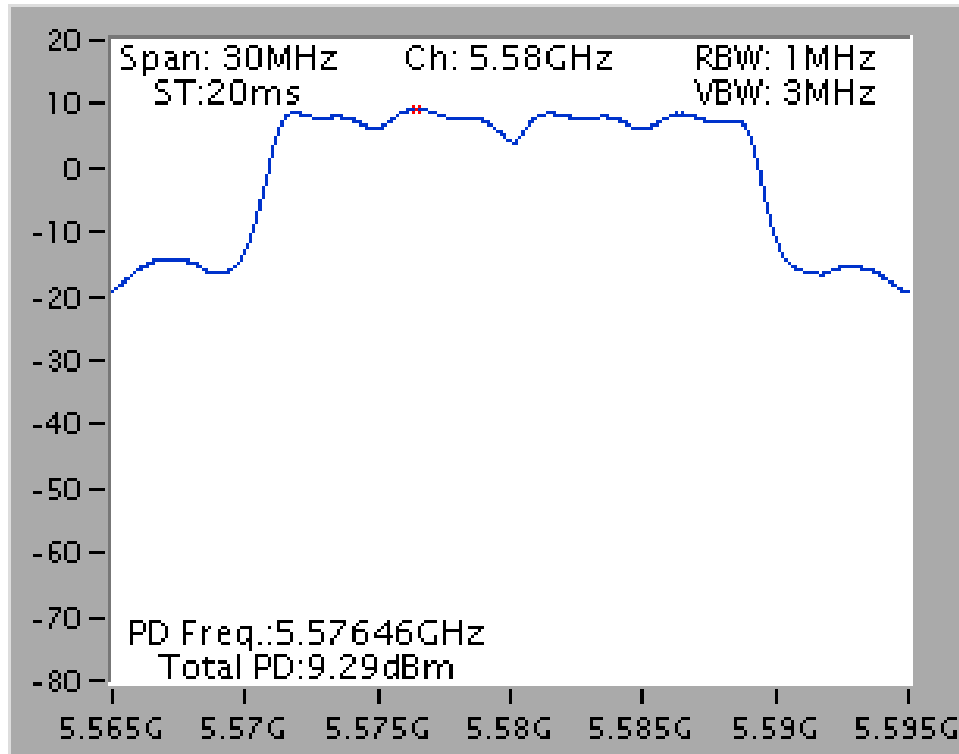

Power Density Plot on Configuration IEEE 802.11n MCS0 40MHz / Chain 1 + Chain 2 + Chain 3  
/ 5230 MHz

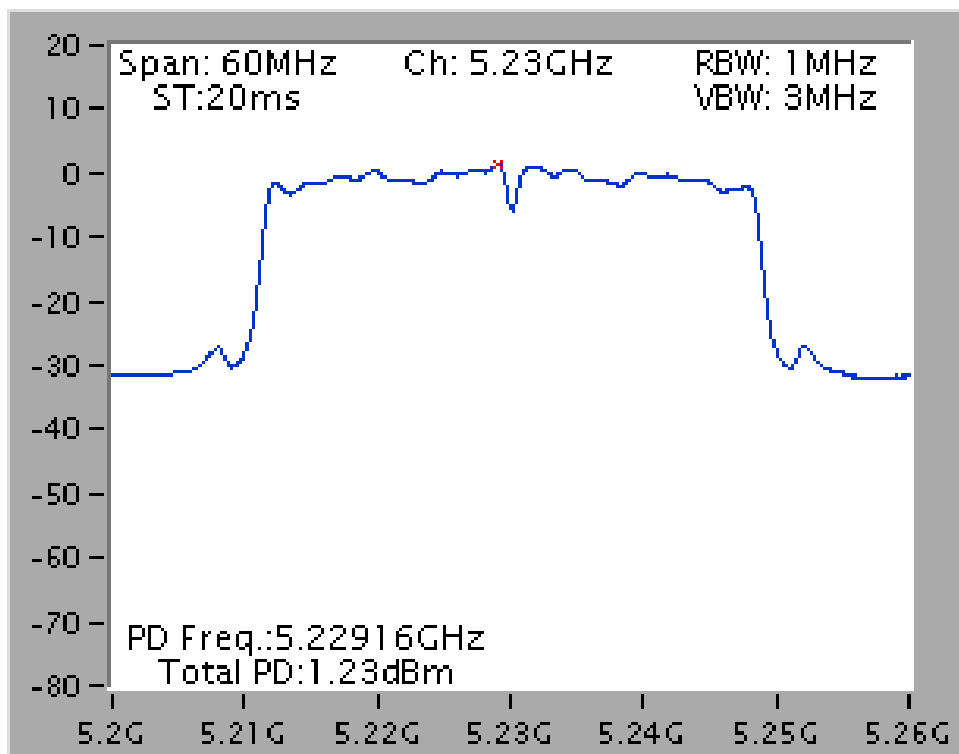

Power Density Plot on Configuration IEEE 802.11n MCS0 40MHz / Chain 1 + Chain 2 + Chain 3  
/ 5270 MHz

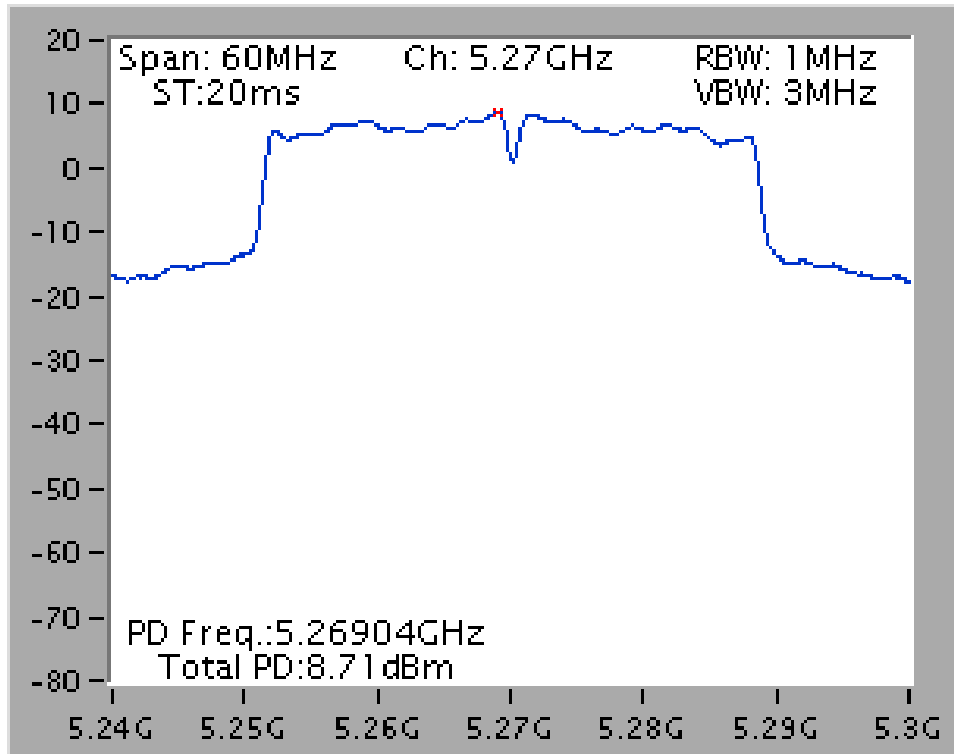

Power Density Plot on Configuration IEEE 802.11n MCS0 40MHz / Chain 1 + Chain 2 + Chain 3  
/ 5550 MHz

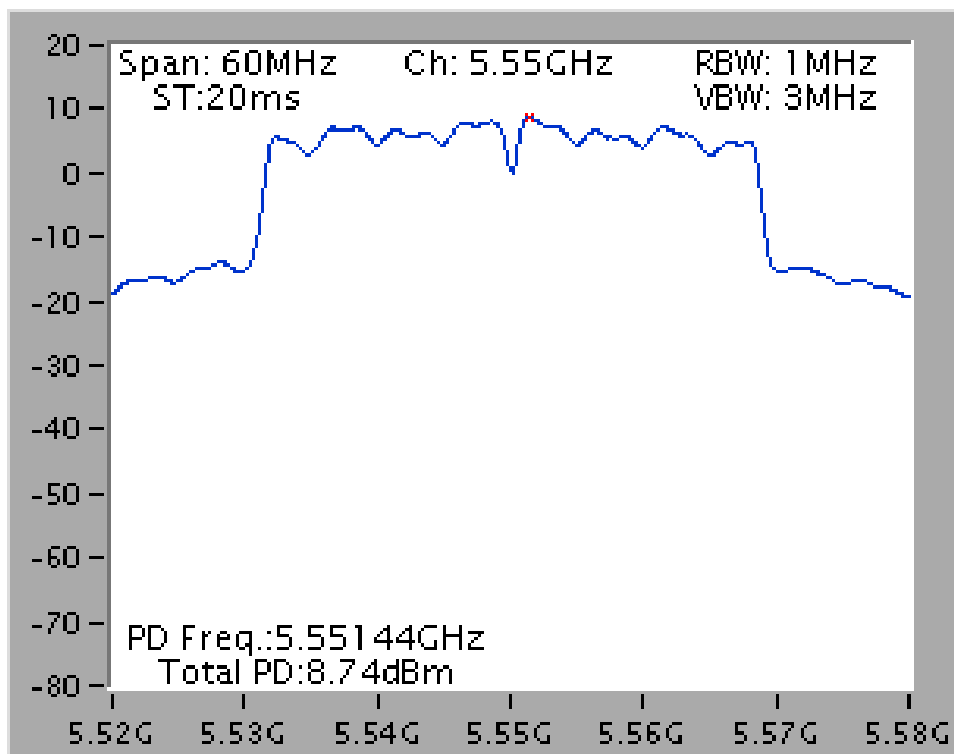



Power Density Plot on Configuration IEEE 802.11a / Chain 1 / 5240 MHz

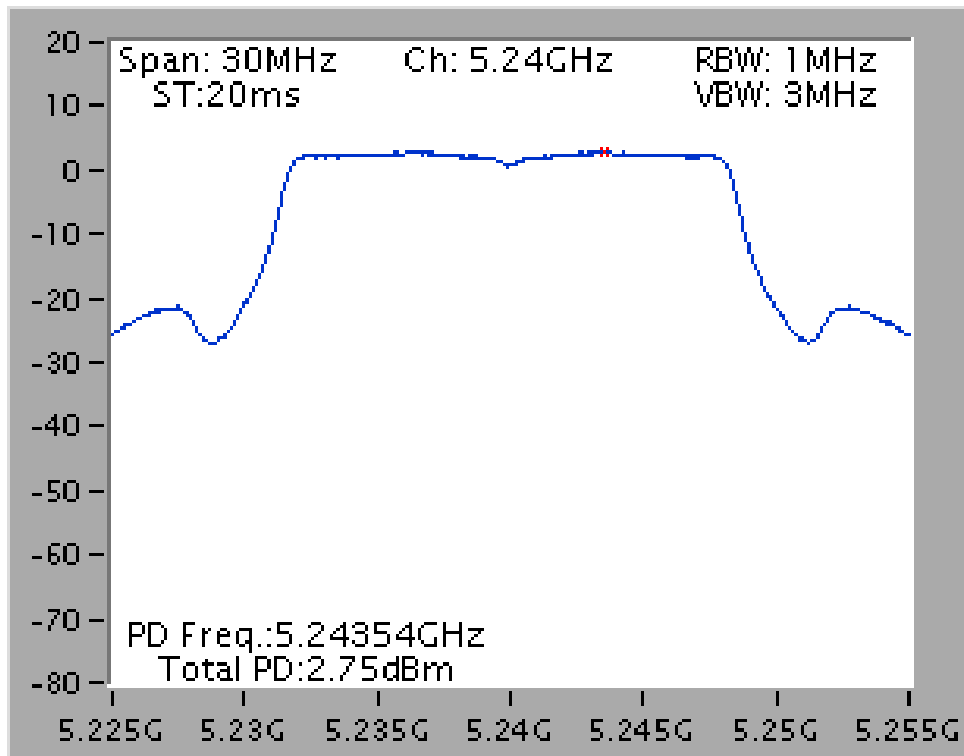

Power Density Plot on Configuration IEEE 802.11a / Chain 1 / 5260 MHz

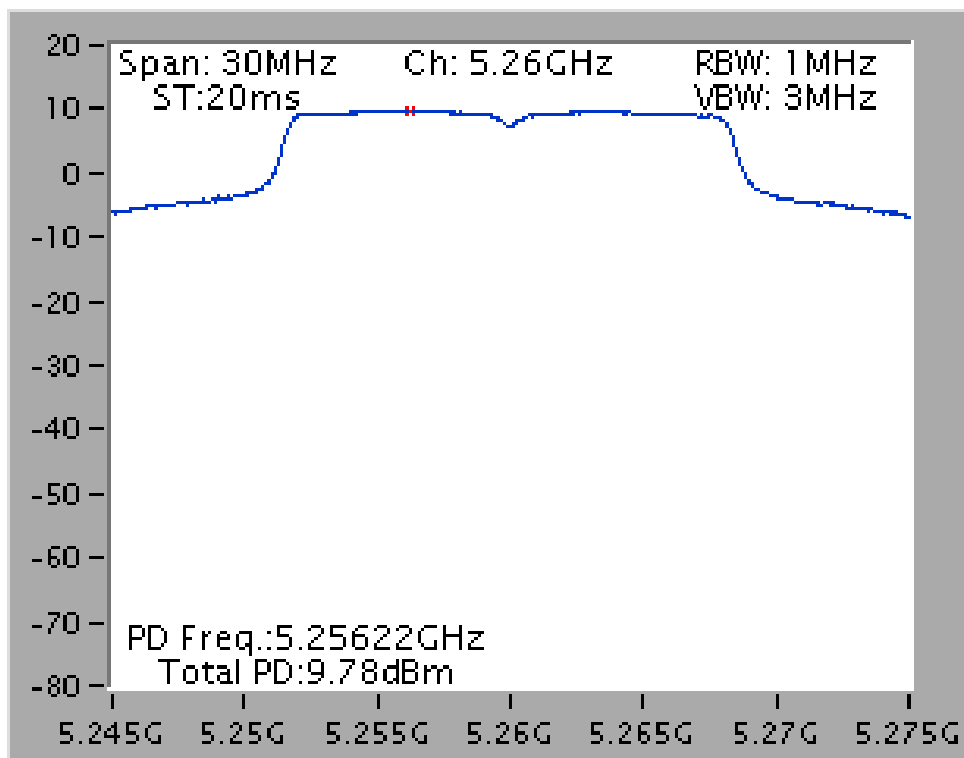

Power Density Plot on Configuration IEEE 802.11a / Chain 1 / 5580 MHz

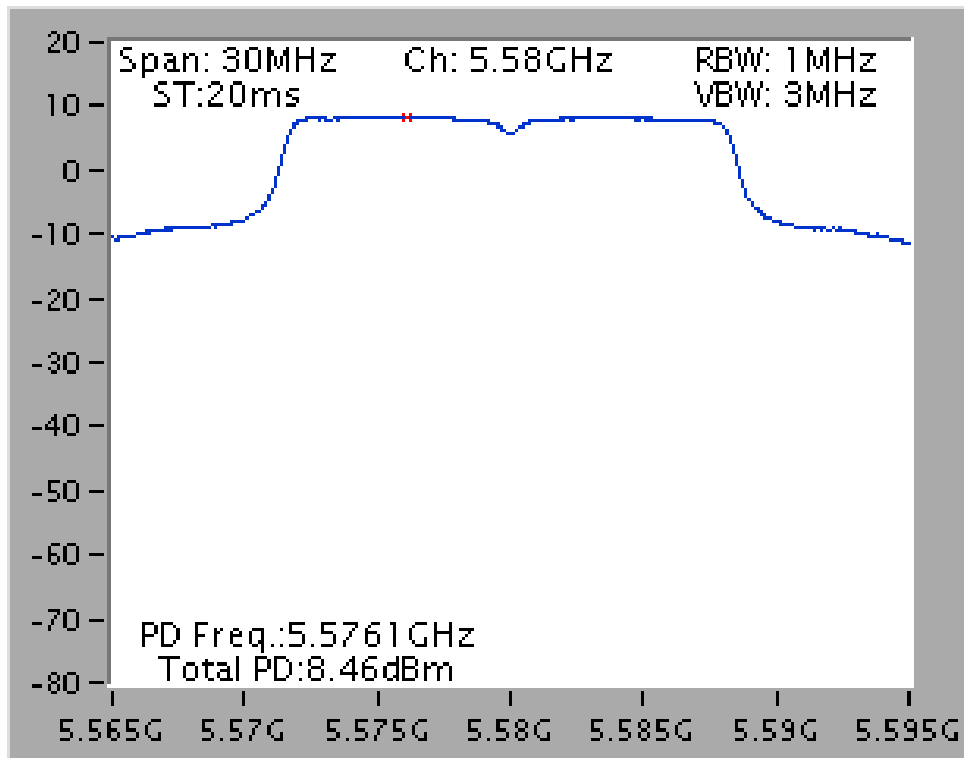

## 4.5. Peak Excursion Measurement

### 4.5.1. Limit

The ratio of the peak excursion of the modulation envelope (measured using a peak hold function) to the maximum conducted output power (measured as specified above) shall not exceed 13 dB across any 1 MHz bandwidth or the emissions bandwidth whichever is less.

### 4.5.2. Measuring Instruments and Setting

Please refer to section 5 of equipments list in this report. The following table is the setting of the spectrum analyzer.

Spectrum Parameter	Setting
Attenuation	Auto
Span Frequency	Encompass the entire emissions bandwidth (EBW) of the signal
RB	1MHz (Peak Trace) / 1MHz (Average Trace)
VB	3MHz (Peak Trace) / 3MHz (Average Trace)
Detector	Peak (Peak Trace) / RMS (Average Trace)
Trace	Peak : Trace :Max hold/Average: Trace Average Sweep Count 100
Sweep Time	AUTO

### 4.5.3. Test Procedures

1. The test procedure is the same as section 4.6.3.
2. Trace A, Set RBW = 1MHz, VBW = 3MHz, Span >26dB bandwidth, Max. hold.
3. Delta Mark trace A Maximum frequency and trace B same frequency.
4. Repeat the above procedure until measurements for all frequencies were complete.

### 4.5.4. Test Setup Layout

This test setup layout is the same as that shown in section 4.6.4.

### 4.5.5. Test Deviation

There is no deviation with the original standard.

### 4.5.6. EUT Operation during Test

The EUT was programmed to be in continuously transmitting mode.

#### 4.5.7. Test Result of Peak Excursion

<b>Temperature</b>	25°C	<b>Humidity</b>	56%
<b>Test Engineer</b>	Benson Peng	<b>Configurations</b>	IEEE 802.11n

##### Configuration IEEE 802.11n MCS0 20MHz / Chain 1 + Chain 2 + Chain 3

Channel	Frequency	Peak Excursion (dB)	Max. Limit (dB)	Result
36	5180 MHz	8.25	13	Complies
52	5260 MHz	9.17	13	Complies
116	5580 MHz	8.06	13	Complies

##### Configuration IEEE 802.11n MCS0 40MHz / Chain 1 + Chain 2 + Chain 3

Channel	Frequency	Peak Excursion (dB)	Max. Limit (dB)	Result
38	5190 MHz	8.88	13	Complies
54	5270 MHz	8.48	13	Complies
110	5550 MHz	8.75	13	Complies

<b>Temperature</b>	25°C	<b>Humidity</b>	56%
<b>Test Engineer</b>	Benson Peng	<b>Configurations</b>	IEEE 802.11a

**Configuration IEEE 802.11a / Chain 1**

<b>Channel</b>	<b>Frequency</b>	<b>Peak Excursion (dB)</b>	<b>Max. Limit (dB)</b>	<b>Result</b>
48	5240 MHz	8.88	13	<b>Complies</b>
52	5260 MHz	9.38	13	<b>Complies</b>
116	5580 MHz	9.50	13	<b>Complies</b>

Note: All the test values were listed in the report.

For plots, only the channel with maximum results was shown.

**Peak Excursion Plot on Configuration IEEE 802.11n MCS0 20MHz / Chain 1 + Chain 2 + Chain 3 / 5180 MHz**

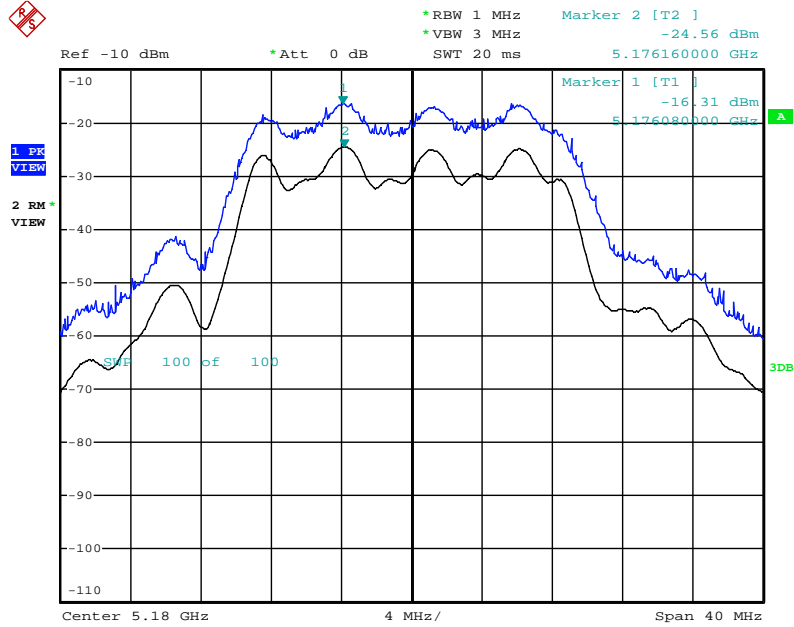

Date: 26.MAR.2013 15:50:01

**Peak Excursion Plot on Configuration IEEE 802.11n MCS0 20MHz / Chain 1 + Chain 2 + Chain 3 / 5260 MHz**

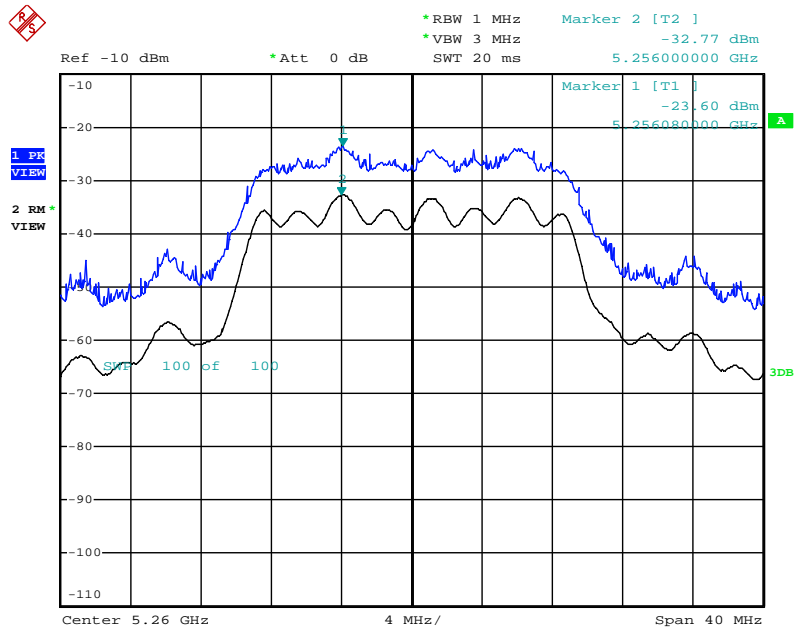

Date: 26.MAR.2013 15:52:59

**Peak Excursion Plot on Configuration IEEE 802.11n MCS0 20MHz / Chain 1 + Chain 2 + Chain 3 / 5580 MHz**

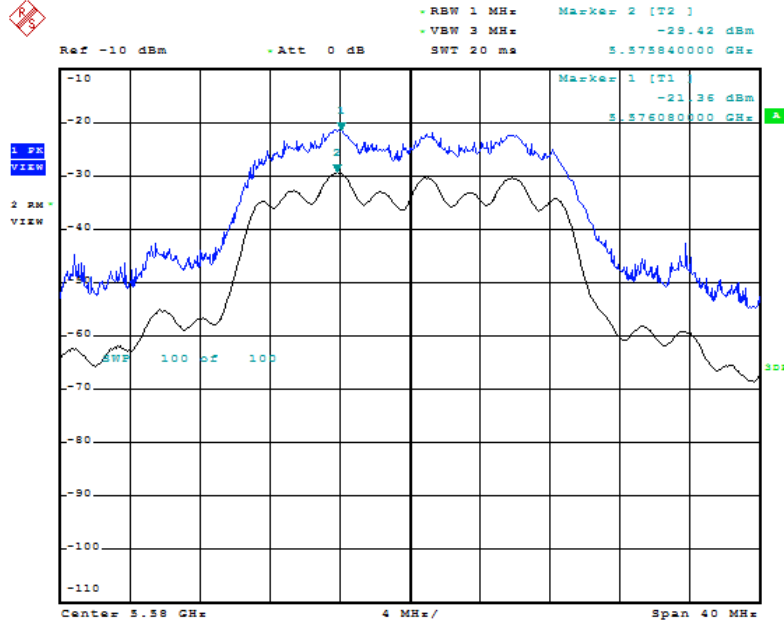

Date: 26.MAR.2013 15:53:42

**Peak Excursion Plot on Configuration IEEE 802.11n MCS0 40MHz / Chain 1 + Chain 2 + Chain 3 / 5190 MHz**

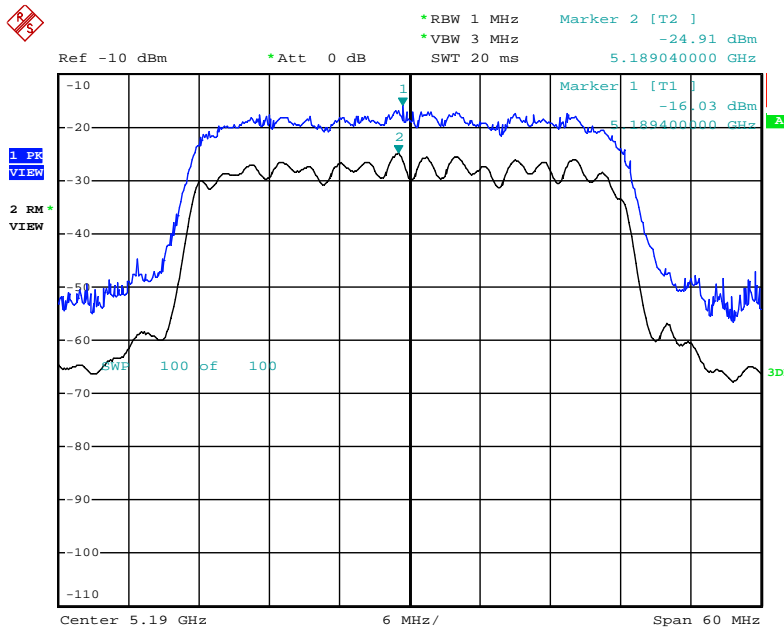

Date: 26.MAR.2013 15:54:43

**Peak Excursion Plot on Configuration IEEE 802.11n MCS0 40MHz / Chain 1 + Chain 2 + Chain 3  
/ 5270 MHz**

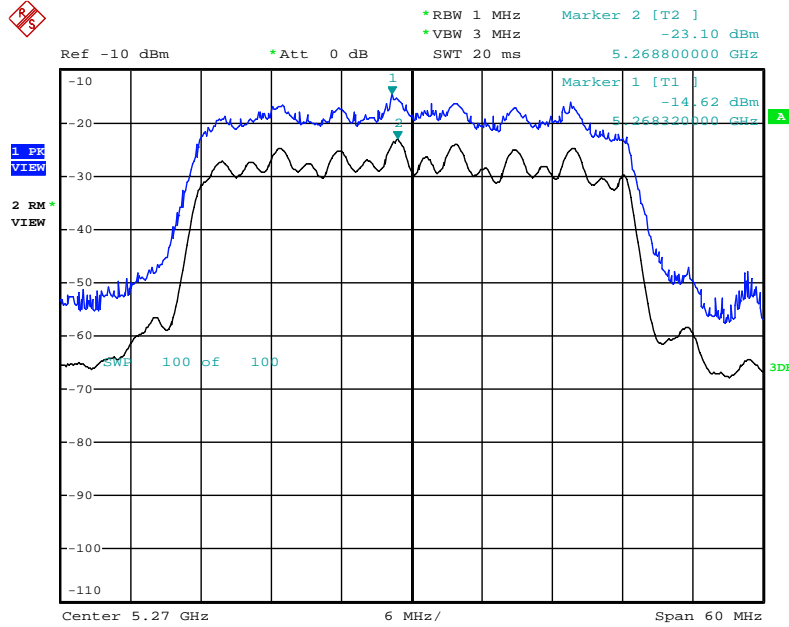

Date: 26.MAR.2013 15:55:33

**Peak Excursion Plot on Configuration IEEE 802.11n MCS0 40MHz / Chain 1 + Chain 2 + Chain 3  
/ 5550 MHz**

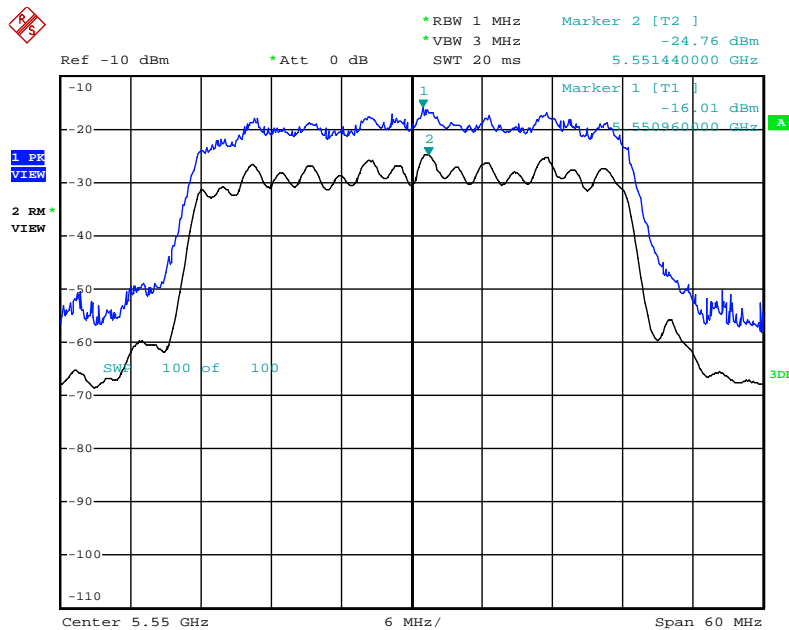

Date: 26.MAR.2013 15:56:13



Peak Excursion Plot on Configuration IEEE 802.11a / Chain 1 / 5240 MHz

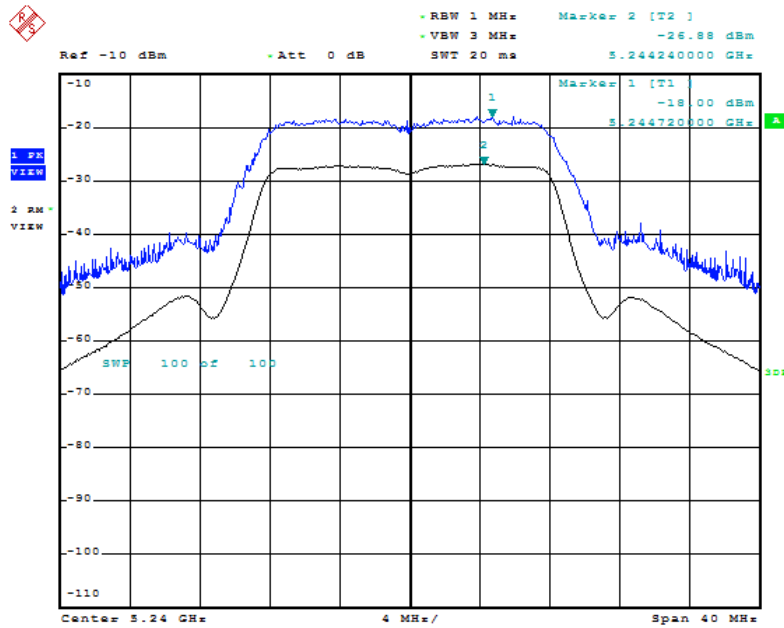

Date: 26.MAR.2013 15:46:43

Peak Excursion Plot on Configuration IEEE 802.11a / Chain 1 / 5260 MHz

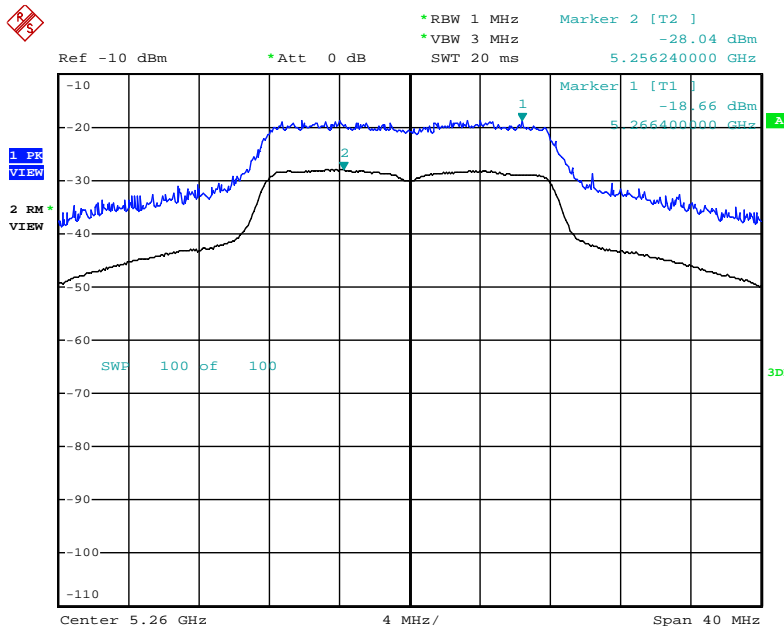

Date: 26.MAR.2013 15:47:56

Peak Excursion Plot on Configuration IEEE 802.11a / Chain 1 / 5580 MHz

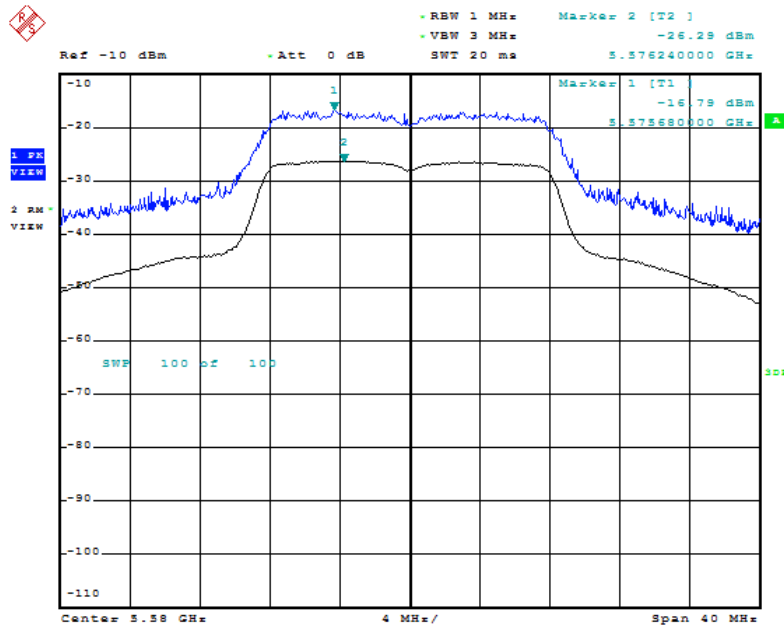

Date: 26.MAR.2013 15:48:43

## 4.6. Radiated Emissions Measurement

### 4.6.1. Limit

For transmitters operating in the 5.15-5.35 GHz band: all emissions outside of the 5.15-5.35 GHz band shall not exceed a -27dBm peak limit or average and peak limits of 15.209. For transmitters operating in the 5.470-5.725 GHz band: all emissions outside of the 5.470-5.725 GHz band shall not exceed a -27dBm peak limit or average and peak limits of 15.209. In addition, In case the emission fall within the restricted band specified on 15.205(a), then the 15.209(a) limit in the table below has to be followed.

Frequencies (MHz)	Field Strength (micровolts/meter)	Measurement Distance (meters)
0.009~0.490	2400/F(KHz)	300
0.490~1.705	24000/F(KHz)	30
1.705~30.0	30	30
30~88	100	3
88~216	150	3
216~960	200	3
Above 960	500	3

### 4.6.2. Measuring Instruments and Setting

Please refer to section 5 of equipments list in this report. The following table is the setting of spectrum analyzer and receiver.

Spectrum Parameter	Setting
Attenuation	Auto
Start Frequency	1000 MHz
Stop Frequency	40 GHz
RB / VB (Emission in restricted band)	1 MHz / 3MHz for Peak, 1 MHz / 10Hz for Average
RB / VB (Emission in non-restricted band)	1 MHz / 3MHz for peak

Receiver Parameter	Setting
Attenuation	Auto
Start ~ Stop Frequency	9kHz~150kHz / RB 200Hz for QP
Start ~ Stop Frequency	150kHz~30MHz / RB 9kHz for QP
Start ~ Stop Frequency	30MHz~1000MHz / RB 120kHz for QP

#### 4.6.3. Test Procedures

1. Configure the EUT according to ANSI C63.10. The EUT was placed on the top of the turntable 0.8 meter above ground. The phase center of the receiving antenna mounted on the top of a height-variable antenna tower was placed 3 meters far away from the turntable.
2. Power on the EUT and all the supporting units. The turntable was rotated by 360 degrees to determine the position of the highest radiation.
3. The height of the broadband receiving antenna was varied between one meter and four meters above ground to find the maximum emissions field strength of both horizontal and vertical polarization.
4. For each suspected emissions, the antenna tower was scan (from 1 M to 4 M) and then the turntable was rotated (from 0 degree to 360 degrees) to find the maximum reading.
5. Set the test-receiver system to Peak or CISPR quasi-peak Detect Function with specified bandwidth under Maximum Hold Mode.
6. For emissions above 1GHz, use 1MHz VBW and RBW for peak reading. Then 1MHz RBW and 10Hz VBW for average reading in spectrum analyzer.
7. When the radiated emissions limits are expressed in terms of the average value of the emissions, and pulsed operation is employed, the measurement field strength shall be determined by averaging over one complete pulse train, including blanking intervals, as long as the pulse train does not exceed 0.1 seconds. As an alternative (provided the transmitter operates for longer than 0.1 seconds) or in cases where the pulse train exceeds 0.1 seconds, the measured field strength shall be determined from the average absolute voltage during a 0.1 second interval during which the field strength is at its maximum value.
8. If the emissions level of the EUT in peak mode was 3 dB lower than the average limit specified, then testing will be stopped and peak values of EUT will be reported, otherwise, the emissions which do not have 3 dB margin will be repeated one by one using the quasi-peak method for below 1GHz.
9. For testing above 1GHz, the emissions level of the EUT in peak mode was lower than average limit (that means the emissions level in peak mode also complies with the limit in average mode), then testing will be stopped and peak values of EUT will be reported, otherwise, the emissions will be measured in average mode again and reported.
10. In case the emission is lower than 30MHz, loop antenna has to be used for measurement and the recorded data should be QP measured by receiver. High – Low scan is not required in this case.

#### 4.6.4. Test Setup Layout

For radiated emissions below 1GHz

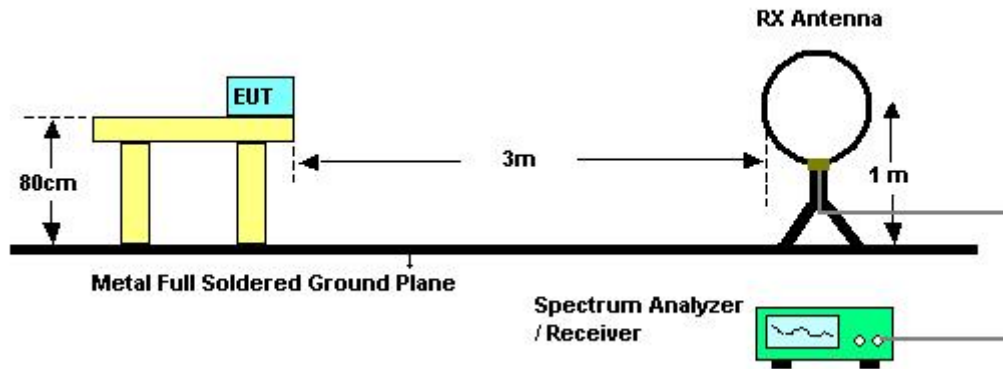

For radiated emissions above 1GHz

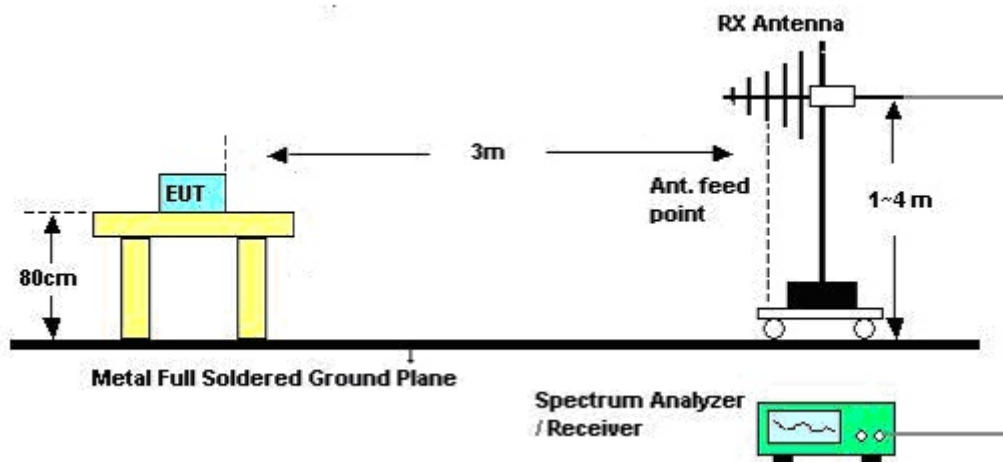

#### 4.6.5. Test Deviation

There is no deviation with the original standard.

#### 4.6.6. Results of Radiated Emissions (9kHz~30MHz)

<b>Temperature</b>	20°C	<b>Humidity</b>	63%
<b>Test Engineer</b>	Serway Li	<b>Configurations</b>	Normal Link
<b>Test Date</b>	Mar. 16, 2013		

<b>Freq. (MHz)</b>	<b>Level (dBuV)</b>	<b>Over Limit (dB)</b>	<b>Limit Line (dBuV)</b>	<b>Remark</b>
-	-	-	-	See Note

Note:

The amplitude of spurious emissions that are attenuated by more than 20dB below the permissible value has no need to be reported.

Distance extrapolation factor =  $40 \log(\text{specific distance} / \text{test distance})$  (dB);

Limit line = specific limits (dBuV) + distance extrapolation factor.

4.6.7. Results of Radiated Emissions (30MHz~1GHz)

Temperature	20°C	Humidity	63%
Test Engineer	Jim Huang	Configurations	Normal Link

Horizontal

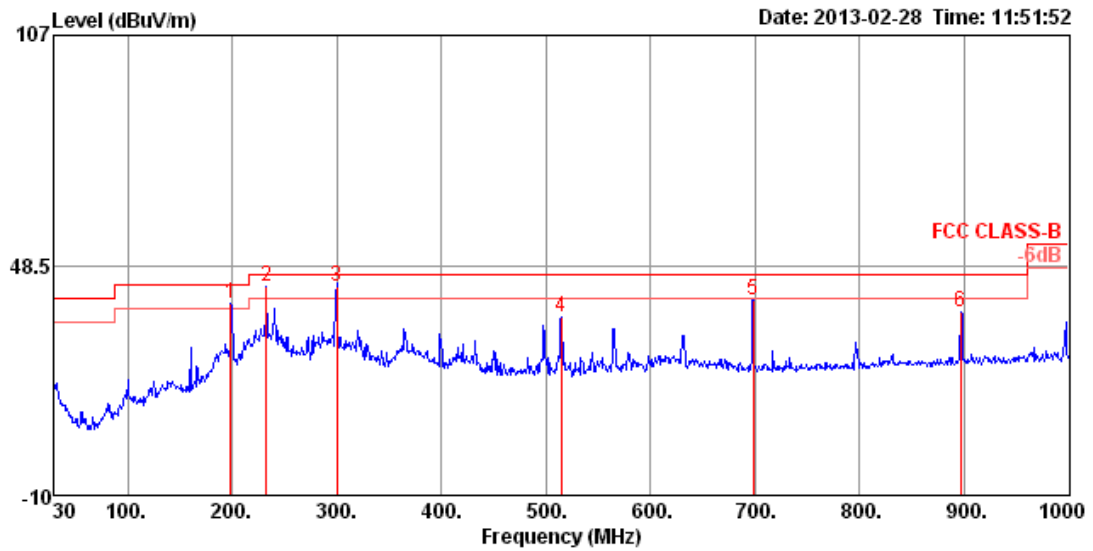

	Freq	Level	Limit	Over	Read	Cable	Antenna	Preamp	A/Pos	T/Pos	Pol/Phase	Remark
	MHz	dBuV/m	dBuV/m	dB	dBuV	dB	dB/m	dB	cm	deg		
1 !	198.78	38.64	43.50	-4.86	59.70	1.70	8.75	31.51	150	336	HORIZONTAL	Peak
2 !	232.73	42.91	46.00	-3.09	62.50	1.84	10.02	31.45	125	357	HORIZONTAL	Peak
3 pp	299.66	42.98	46.00	-3.02	59.25	2.13	13.02	31.42	125	215	HORIZONTAL	Peak
4	515.00	35.35	46.00	-10.65	46.60	2.86	17.30	31.41	200	346	HORIZONTAL	Peak
5	698.33	39.75	46.00	-6.25	48.73	3.41	18.92	31.31	150	219	HORIZONTAL	Peak
6	896.21	36.66	46.00	-9.34	43.27	3.97	20.61	31.19	125	262	HORIZONTAL	Peak

**Vertical**

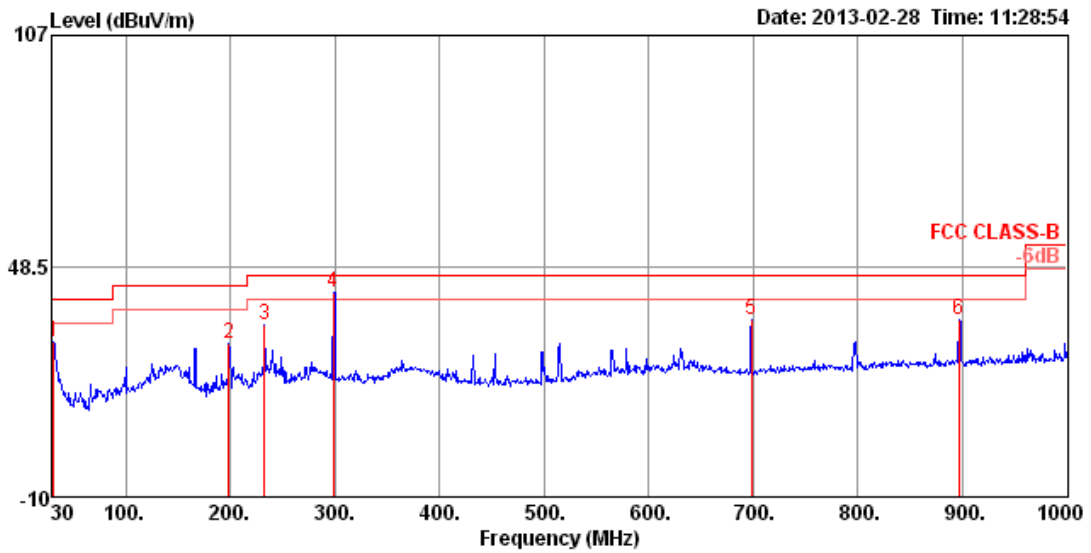

	Freq	Level	Limit	Over	Read	Cable	Antenna	Preamp	A/Pos	T/Pos	Pol/Phase	Remark
	MHz	dBuV/m	dBuV/m	dB	dBuV	dB	dB/m	dB	cm	deg		
1	30.97	29.30	40.00	-10.70	43.03	0.65	17.44	31.82	100	83	VERTICAL	Peak
2	198.78	28.94	43.50	-14.56	50.00	1.70	8.75	31.51	200	289	VERTICAL	Peak
3	232.73	33.80	46.00	-12.20	53.39	1.84	10.02	31.45	125	268	VERTICAL	Peak
4 pp	298.69	41.96	46.00	-4.04	58.29	2.12	12.98	31.43	150	263	VERTICAL	Peak
5	698.33	34.76	46.00	-11.24	43.74	3.41	18.92	31.31	100	53	VERTICAL	Peak
6	896.21	34.89	46.00	-11.11	41.50	3.97	20.61	31.19	150	304	VERTICAL	Peak

**Note:**

The amplitude of spurious emissions that are attenuated by more than 20dB below the permissible value has no need to be reported.

Emission level (dBuV/m) = 20 log Emission level (uV/m).

Corrected Reading: Antenna Factor + Cable Loss + Read Level - Preamp Factor = Level.



## 4.6.8. Results for Radiated Emissions (1GHz~40GHz)

<b>Temperature</b>	20°C	<b>Humidity</b>	63%
<b>Test Engineer</b>	Serway Li	<b>Configurations</b>	IEEE 802.11n MCS0 20MHz Ch 36 / Chain 1 + Chain 2 + Chain 3
<b>Test Date</b>	Mar. 16, 2013		

**Horizontal**

	Freq	Level	Limit Line	Over Limit	Read Level	Cable Loss	Preamp Factor	Antenna Factor	Remark	T/Pos	A/Pos	Pol/Phase
	MHz	dBuV/m	dBuV/m	dB	dBuV	dB	dB	dB/m		deg	cm	
1 a	15539.77	40.36	54.00	-13.64	28.81	7.85	34.79	38.49	Average	306	100	HORIZONTAL
2 p	15540.25	53.20	74.00	-20.80	41.65	7.85	34.79	38.49	Peak	306	100	HORIZONTAL

**Vertical**

	Freq	Level	Limit Line	Over Limit	Read Level	Cable Loss	Preamp Factor	Antenna Factor	Remark	T/Pos	A/Pos	Pol/Phase
	MHz	dBuV/m	dBuV/m	dB	dBuV	dB	dB	dB/m		deg	cm	
1 a	15539.54	40.23	54.00	-13.77	28.68	7.85	34.79	38.49	Average	126	100	VERTICAL
2 p	15540.19	53.10	74.00	-20.90	41.55	7.85	34.79	38.49	Peak	126	100	VERTICAL

<b>Temperature</b>	20°C	<b>Humidity</b>	63%
<b>Test Engineer</b>	Serway Li	<b>Configurations</b>	IEEE 802.11n MCS0 20MHz Ch 40 / Chain 1 + Chain 2 + Chain 3
<b>Test Date</b>	Mar. 16, 2013		

### Horizontal

	Freq	Level	Limit	Over	Read	Cable	Preamp	Antenna	Remark	T/Pos	A/Pos	Pol/Phase
	MHz	dBuV/m	dBuV/m	dB	dBuV	dB	dB	dB/m		deg	cm	
1 a	15598.96	39.97	54.00	-14.03	28.47	7.88	34.86	38.48	Average	152	100	HORIZONTAL
2 p	15600.24	52.44	74.00	-21.56	40.94	7.88	34.86	38.48	Peak	152	100	HORIZONTAL

### Vertical

	Freq	Level	Limit	Over	Read	Cable	Preamp	Antenna	Remark	T/Pos	A/Pos	Pol/Phase
	MHz	dBuV/m	dBuV/m	dB	dBuV	dB	dB	dB/m		deg	cm	
1 p	15600.24	53.03	74.00	-20.97	41.53	7.88	34.86	38.48	Peak	277	100	VERTICAL
2 a	15600.46	40.03	54.00	-13.97	28.53	7.88	34.86	38.48	Average	277	100	VERTICAL

<b>Temperature</b>	20°C	<b>Humidity</b>	63%
<b>Test Engineer</b>	Serway Li	<b>Configurations</b>	IEEE 802.11n MCS0 20MHz Ch 48 / Chain 1 + Chain 2 + Chain 3
<b>Test Date</b>	Mar. 16, 2013		

### Horizontal

	Freq	Level	Limit	Over	Read	Cable	Preamp	Antenna	Remark	T/Pos	A/Pos	Pol/Phase
	MHz	dBuV/m	dBuV/m	dB	dBuV	dB	dB	dB/m		deg	cm	
1 a	15719.58	40.18	54.00	-13.82	28.74	7.92	34.94	38.46	Average	239	100	HORIZONTAL
2 p	15720.38	52.74	74.00	-21.26	41.30	7.92	34.94	38.46	Peak	239	100	HORIZONTAL

### Vertical

	Freq	Level	Limit	Over	Read	Cable	Preamp	Antenna	Remark	T/Pos	A/Pos	Pol/Phase
	MHz	dBuV/m	dBuV/m	dB	dBuV	dB	dB	dB/m		deg	cm	
1 p	15719.72	53.67	74.00	-20.33	42.23	7.92	34.94	38.46	Peak	104	100	VERTICAL
2 a	15719.89	40.23	54.00	-13.77	28.79	7.92	34.94	38.46	Average	104	100	VERTICAL

<b>Temperature</b>	20°C	<b>Humidity</b>	63%
<b>Test Engineer</b>	Serway Li	<b>Configurations</b>	IEEE 802.11n MCS0 20MHz Ch 52 / Chain 1 + Chain 2 + Chain 3
<b>Test Date</b>	Mar. 16, 2013		

### Horizontal

	Freq	Level	Limit Line	Over Limit	Read Level	Cable Loss	Preamp Factor	Antenna Factor	Remark	T/Pos	A/Pos	Pol/Phase
	MHz	dBuV/m	dBuV/m	dB	dBuV	dB	dB	dB/m		deg	cm	
1 a	15779.54	40.40	54.00	-13.60	29.04	7.93	35.01	38.44	Average	226	100	HORIZONTAL
2 p	15780.40	53.24	74.00	-20.76	41.88	7.93	35.01	38.44	Peak	226	100	HORIZONTAL

### Vertical

	Freq	Level	Limit Line	Over Limit	Read Level	Cable Loss	Preamp Factor	Antenna Factor	Remark	T/Pos	A/Pos	Pol/Phase
	MHz	dBuV/m	dBuV/m	dB	dBuV	dB	dB	dB/m		deg	cm	
1 a	15779.93	40.51	54.00	-13.49	29.15	7.93	35.01	38.44	Average	91	100	VERTICAL
2 p	15780.28	53.70	74.00	-20.30	42.34	7.93	35.01	38.44	Peak	91	100	VERTICAL



<b>Temperature</b>	20°C	<b>Humidity</b>	63%
<b>Test Engineer</b>	Serway Li	<b>Configurations</b>	IEEE 802.11n MCS0 20MHz Ch 60 / Chain 1 + Chain 2 + Chain 3
<b>Test Date</b>	Mar. 16, 2013		

**Horizontal**

	Freq	Level	Limit Line	Over Limit	Read Level	Cable Loss	Preamp Factor	Antenna Factor	Remark	T/Pos	A/Pos	Pol/Phase
	MHz	dBuV/m	dBuV/m	dB	dBuV	dB	dB	dB/m		deg	cm	
1 a	10600.32	36.96	54.00	-17.04	27.00	6.60	35.12	38.48	Average	228	100	HORIZONTAL
2 p	10600.64	49.26	74.00	-24.74	39.30	6.60	35.12	38.48	Peak	228	100	HORIZONTAL

**Vertical**

	Freq	Level	Limit Line	Over Limit	Read Level	Cable Loss	Preamp Factor	Antenna Factor	Remark	T/Pos	A/Pos	Pol/Phase
	MHz	dBuV/m	dBuV/m	dB	dBuV	dB	dB	dB/m		deg	cm	
1 p	10600.30	48.11	74.00	-25.89	38.15	6.60	35.12	38.48	Peak	102	117	VERTICAL
2 a	10600.30	37.34	54.00	-16.66	27.38	6.60	35.12	38.48	Average	102	117	VERTICAL



<b>Temperature</b>	20°C	<b>Humidity</b>	63%
<b>Test Engineer</b>	Serway Li	<b>Configurations</b>	IEEE 802.11n MCS0 20MHz Ch 64 / Chain 1 + Chain 2 + Chain 3
<b>Test Date</b>	Mar. 16, 2013		

**Horizontal**

	Freq	Level	Limit Line	Over Limit	Read Level	Cable Loss	Preamp Factor	Antenna Factor	Remark	T/Pos	A/Pos	Pol/Phase
	MHz	dBuV/m	dBuV/m	dB	dBuV	dB	dB	dB/m		deg	cm	
1 a	10639.90	37.35	54.00	-16.65	27.37	6.59	35.08	38.47	Average	164	100	HORIZONTAL
2 p	10640.37	50.48	74.00	-23.52	40.50	6.59	35.08	38.47	Peak	164	100	HORIZONTAL

**Vertical**

	Freq	Level	Limit Line	Over Limit	Read Level	Cable Loss	Preamp Factor	Antenna Factor	Remark	T/Pos	A/Pos	Pol/Phase
	MHz	dBuV/m	dBuV/m	dB	dBuV	dB	dB	dB/m		deg	cm	
1 a	10640.21	37.90	54.00	-16.10	27.92	6.59	35.08	38.47	Average	324	100	VERTICAL
2 p	10640.35	51.09	74.00	-22.91	41.11	6.59	35.08	38.47	Peak	324	100	VERTICAL



<b>Temperature</b>	20°C	<b>Humidity</b>	63%
<b>Test Engineer</b>	Serway Li	<b>Configurations</b>	IEEE 802.11n MCS0 20MHz Ch 100 / Chain 1 + Chain 2 + Chain 3
<b>Test Date</b>	Mar. 16, 2013		

**Horizontal**

	Freq	Level	Limit Line	Over Limit	Read Level	Cable Loss	Preamp Factor	Antenna Factor	Remark	T/Pos	A/Pos	Pol/Phase
	MHz	dBuV/m	dBuV/m	dB	dBuV	dB	dB	dB/m		deg	cm	
1 a	11000.08	37.84	54.00	-16.16	27.79	6.46	34.81	38.40	Average	46	100	HORIZONTAL
2 p	11000.25	50.25	74.00	-23.75	40.20	6.46	34.81	38.40	Peak	46	100	HORIZONTAL

**Vertical**

	Freq	Level	Limit Line	Over Limit	Read Level	Cable Loss	Preamp Factor	Antenna Factor	Remark	T/Pos	A/Pos	Pol/Phase
	MHz	dBuV/m	dBuV/m	dB	dBuV	dB	dB	dB/m		deg	cm	
1 p	10999.73	50.51	74.00	-23.49	40.46	6.46	34.81	38.40	Peak	180	100	VERTICAL
2 a	11000.02	37.73	54.00	-16.27	27.68	6.46	34.81	38.40	Average	180	100	VERTICAL

<b>Temperature</b>	20°C	<b>Humidity</b>	63%
<b>Test Engineer</b>	Serway Li	<b>Configurations</b>	IEEE 802.11n MCS0 20MHz Ch 116 / Chain 1 + Chain 2 + Chain 3
<b>Test Date</b>	Mar. 16, 2013		

### Horizontal

	Freq	Level	Limit	Over	Read	Cable	Preamp	Antenna	Remark	T/Pos	A/Pos	Pol/Phase
	MHz	dBuV/m	dBuV/m	dB	dBuV	dB	dB	dB/m		deg	cm	
1 a	11158.80	42.73	54.00	-11.27	32.55	6.56	34.81	38.43	Average	103	121	HORIZONTAL
2 p	11159.08	56.98	74.00	-17.02	46.80	6.56	34.81	38.43	Peak	103	121	HORIZONTAL

### Vertical

	Freq	Level	Limit	Over	Read	Cable	Preamp	Antenna	Remark	T/Pos	A/Pos	Pol/Phase
	MHz	dBuV/m	dBuV/m	dB	dBuV	dB	dB	dB/m		deg	cm	
1 a	11158.08	43.62	54.00	-10.38	33.44	6.56	34.81	38.43	Average	358	100	VERTICAL
2 p	11162.60	56.34	74.00	-17.66	46.16	6.56	34.81	38.43	Peak	358	100	VERTICAL





<b>Temperature</b>	20°C	<b>Humidity</b>	63%
<b>Test Engineer</b>	Serway Li	<b>Configurations</b>	IEEE 802.11n MCS0 20MHz Ch 140 / Chain 1 + Chain 2 + Chain 3
<b>Test Date</b>	Mar. 16, 2013		

**Horizontal**

	Freq	Level	Limit Line	Over Limit	Read Level	Cable Loss	Preamp Factor	Antenna Factor	Remark	T/Pos	A/Pos	Pol/Phase
	MHz	dBuV/m	dBuV/m	dB	dBuV	dB	dB	dB/m		deg	cm	
1 a	11405.12	38.70	54.00	-15.30	28.35	6.69	34.82	38.48	Average	191	100	HORIZONTAL
2 p	11405.20	50.84	74.00	-23.16	40.49	6.69	34.82	38.48	Peak	191	100	HORIZONTAL

**Vertical**

	Freq	Level	Limit Line	Over Limit	Read Level	Cable Loss	Preamp Factor	Antenna Factor	Remark	T/Pos	A/Pos	Pol/Phase
	MHz	dBuV/m	dBuV/m	dB	dBuV	dB	dB	dB/m		deg	cm	
1 a	11398.32	39.82	54.00	-14.18	29.47	6.69	34.82	38.48	Average	25	100	VERTICAL
2 p	11403.88	51.39	74.00	-22.61	41.04	6.69	34.82	38.48	Peak	25	100	VERTICAL



<b>Temperature</b>	20°C	<b>Humidity</b>	63%
<b>Test Engineer</b>	Serway Li	<b>Configurations</b>	IEEE 802.11n MCS0 40MHz Ch 38 / Chain 1 + Chain 2 + Chain 3
<b>Test Date</b>	Mar. 16, 2013		

**Horizontal**

	Freq	Level	Limit Line	Over Limit	Read Level	Cable Loss	Preamp Factor	Antenna Factor	Remark	T/Pos	A/Pos	Pol/Phase
	MHz	dBuV/m	dBuV/m	dB	dBuV	dB	dB	dB/m		deg	cm	
1 a	15570.09	40.47	54.00	-13.53	28.93	7.86	34.81	38.49	Average	139	100	HORIZONTAL
2 p	15570.20	53.24	74.00	-20.76	41.70	7.86	34.81	38.49	Peak	139	100	HORIZONTAL

**Vertical**

	Freq	Level	Limit Line	Over Limit	Read Level	Cable Loss	Preamp Factor	Antenna Factor	Remark	T/Pos	A/Pos	Pol/Phase
	MHz	dBuV/m	dBuV/m	dB	dBuV	dB	dB	dB/m		deg	cm	
1 a	15569.98	40.34	54.00	-13.66	28.80	7.86	34.81	38.49	Average	249	100	VERTICAL
2 p	15570.13	53.51	74.00	-20.49	41.97	7.86	34.81	38.49	Peak	249	100	VERTICAL



<b>Temperature</b>	20°C	<b>Humidity</b>	63%
<b>Test Engineer</b>	Serway Li	<b>Configurations</b>	IEEE 802.11n MCS0 40MHz Ch 46 / Chain 1 + Chain 2 + Chain 3
<b>Test Date</b>	Mar. 16, 2013		

**Horizontal**

	Freq	Level	Limit Line	Over Limit	Read Level	Cable Loss	Preamp Factor	Antenna Factor	Remark	T/Pos	A/Pos	Pol/Phase
	MHz	dBuV/m	dBuV/m	dB	dBuV	dB	dB	dB/m		deg	cm	
1 a	15689.57	41.04	54.00	-12.96	29.60	7.90	34.92	38.46	Average	280	100	HORIZONTAL
2 p	15690.34	53.66	74.00	-20.34	42.22	7.90	34.92	38.46	Peak	280	100	HORIZONTAL

**Vertical**

	Freq	Level	Limit Line	Over Limit	Read Level	Cable Loss	Preamp Factor	Antenna Factor	Remark	T/Pos	A/Pos	Pol/Phase
	MHz	dBuV/m	dBuV/m	dB	dBuV	dB	dB	dB/m		deg	cm	
1 a	15690.38	41.79	54.00	-12.21	30.35	7.90	34.92	38.46	Average	154	100	VERTICAL
2 p	15690.40	54.07	74.00	-19.93	42.63	7.90	34.92	38.46	Peak	154	100	VERTICAL



<b>Temperature</b>	20°C	<b>Humidity</b>	63%
<b>Test Engineer</b>	Serway Li	<b>Configurations</b>	IEEE 802.11n MCS0 40MHz Ch 54 / Chain 1 + Chain 2 + Chain 3
<b>Test Date</b>	Mar. 16, 2013		

**Horizontal**

	Freq	Level	Limit	Over	Read	Cable	Preamp	Antenna	Remark	T/Pos	A/Pos	Pol/Phase
	MHz	dBuV/m	dBuV/m	dB	dBuV	dB	dB	dB/m		deg	cm	
1 p	10539.68	50.21	74.00	-23.79	40.25	6.63	35.16	38.49	Peak	210	100	HORIZONTAL
2 a	10540.24	38.47	54.00	-15.53	28.51	6.63	35.16	38.49	Average	210	100	HORIZONTAL

**Vertical**

	Freq	Level	Limit	Over	Read	Cable	Preamp	Antenna	Remark	T/Pos	A/Pos	Pol/Phase
	MHz	dBuV/m	dBuV/m	dB	dBuV	dB	dB	dB/m		deg	cm	
1 p	10522.80	52.10	74.00	-21.90	42.15	6.63	35.18	38.50	Peak	43	100	VERTICAL
2 a	10547.60	39.62	54.00	-14.38	29.67	6.62	35.16	38.49	Average	43	100	VERTICAL

<b>Temperature</b>	20°C	<b>Humidity</b>	63%
<b>Test Engineer</b>	Serway Li	<b>Configurations</b>	IEEE 802.11n MCS0 40MHz Ch 62 / Chain 1 + Chain 2 + Chain 3
<b>Test Date</b>	Mar. 16, 2013		

### Horizontal

	Freq	Level	Limit	Over	Read	Cable	Preamp	Antenna	Remark	T/Pos	A/Pos	Pol/Phase
	MHz	dBuV/m	dBuV/m	dB	dBuV	dB	dB	dB/m		deg	cm	
1 p	10619.74	50.72	74.00	-23.28	40.74	6.60	35.10	38.48	Peak	203	100	HORIZONTAL
2 a	10619.79	37.06	54.00	-16.94	27.08	6.60	35.10	38.48	Average	203	100	HORIZONTAL

### Vertical

	Freq	Level	Limit	Over	Read	Cable	Preamp	Antenna	Remark	T/Pos	A/Pos	Pol/Phase
	MHz	dBuV/m	dBuV/m	dB	dBuV	dB	dB	dB/m		deg	cm	
1 p	10619.69	49.77	74.00	-24.23	39.79	6.60	35.10	38.48	Peak	293	100	VERTICAL
2 a	10619.99	37.12	54.00	-16.88	27.14	6.60	35.10	38.48	Average	293	100	VERTICAL

<b>Temperature</b>	20°C	<b>Humidity</b>	63%
<b>Test Engineer</b>	Serway Li	<b>Configurations</b>	IEEE 802.11n MCS0 40MHz Ch 102 / Chain 1 + Chain 2 + Chain 3
<b>Test Date</b>	Mar. 16, 2013		

### Horizontal

	Freq	Level	Limit	Over	Read	Cable	Preamp	Antenna	Remark	T/Pos	A/Pos	Pol/Phase
	MHz	dBuV/m	dBuV/m	dB	dBuV	dB	dB	dB/m		deg	cm	
1 p	11019.60	51.55	74.00	-22.45	41.49	6.47	34.81	38.40	Peak	133	100	HORIZONTAL
2 a	11020.50	37.99	54.00	-16.01	27.93	6.47	34.81	38.40	Average	133	100	HORIZONTAL

### Vertical

	Freq	Level	Limit	Over	Read	Cable	Preamp	Antenna	Remark	T/Pos	A/Pos	Pol/Phase
	MHz	dBuV/m	dBuV/m	dB	dBuV	dB	dB	dB/m		deg	cm	
1 a	11019.73	37.75	54.00	-16.25	27.69	6.47	34.81	38.40	Average	218	100	VERTICAL
2 p	11020.35	50.80	74.00	-23.20	40.74	6.47	34.81	38.40	Peak	218	100	VERTICAL



<b>Temperature</b>	20°C	<b>Humidity</b>	63%
<b>Test Engineer</b>	Serway Li	<b>Configurations</b>	IEEE 802.11n MCS0 40MHz Ch 110 / Chain 1 + Chain 2 + Chain 3
<b>Test Date</b>	Mar. 16, 2013		

**Horizontal**

	Freq	Level	Limit Line	Over Limit	Read Level	Cable Loss	Preamp Factor	Antenna Factor	Remark	T/Pos	A/Pos	Pol/Phase
	MHz	dBuV/m	dBuV/m	dB	dBuV	dB	dB	dB/m		deg	cm	
1 a	11099.00	38.36	54.00	-15.64	28.23	6.52	34.81	38.42	Average	111	100	HORIZONTAL
2 p	11105.90	50.88	74.00	-23.12	40.75	6.52	34.81	38.42	Peak	111	100	HORIZONTAL

**Vertical**

	Freq	Level	Limit Line	Over Limit	Read Level	Cable Loss	Preamp Factor	Antenna Factor	Remark	T/Pos	A/Pos	Pol/Phase
	MHz	dBuV/m	dBuV/m	dB	dBuV	dB	dB	dB/m		deg	cm	
1 a	11097.80	39.75	54.00	-14.25	29.62	6.52	34.81	38.42	Average	355	100	VERTICAL
2 p	11104.80	52.75	74.00	-21.25	42.62	6.52	34.81	38.42	Peak	355	100	VERTICAL

<b>Temperature</b>	20°C	<b>Humidity</b>	63%
<b>Test Engineer</b>	Serway Li	<b>Configurations</b>	IEEE 802.11n MCS0 40MHz Ch 134 / Chain 1 + Chain 2 + Chain 3
<b>Test Date</b>	Mar. 16, 2013		

### Horizontal

	Freq	Level	Limit	Over	Read	Cable	Preamp	Antenna	Remark	T/Pos	A/Pos	Pol/Phase
	MHz	dBuV/m	dBuV/m	dB	dBuV	dB	dB	dB/m		deg	cm	
1 a	11351.00	38.60	54.00	-15.40	28.29	6.66	34.82	38.47	Average	213	100	HORIZONTAL
2 p	11353.30	50.14	74.00	-23.86	39.83	6.66	34.82	38.47	Peak	213	100	HORIZONTAL

### Vertical

	Freq	Level	Limit	Over	Read	Cable	Preamp	Antenna	Remark	T/Pos	A/Pos	Pol/Phase
	MHz	dBuV/m	dBuV/m	dB	dBuV	dB	dB	dB/m		deg	cm	
1 p	11339.59	50.52	74.00	-23.48	40.22	6.65	34.82	38.47	Peak	93	100	VERTICAL
2 a	11340.26	38.70	54.00	-15.30	28.40	6.65	34.82	38.47	Average	93	100	VERTICAL

### Note:

The amplitude of spurious emissions that are attenuated by more than 20dB below the permissible value has no need to be reported.

Emission level (dBuV/m) = 20 log Emission level (uV/m).

Corrected Reading: Antenna Factor + Cable Loss + Read Level - Preamp Factor = Level.





<b>Temperature</b>	20°C	<b>Humidity</b>	63%
<b>Test Engineer</b>	Serway Li	<b>Configurations</b>	IEEE 802.11a Ch 36 / Chain 1
<b>Test Date</b>	Mar. 16, 2013		

**Horizontal**

	Freq	Level	Limit Line	Over Limit	Read Level	Cable Loss	Preamp Factor	Antenna Factor	Remark	T/Pos	A/Pos	Pol/Phase
	MHz	dBuV/m	dBuV/m	dB	dBuV	dB	dB	dB/m		deg	cm	
1 a	15539.58	40.36	54.00	-13.64	28.81	7.85	34.79	38.49	Average	323	100	HORIZONTAL
2 p	15539.77	53.19	74.00	-20.81	41.64	7.85	34.79	38.49	Peak	323	100	HORIZONTAL

**Vertical**

	Freq	Level	Limit Line	Over Limit	Read Level	Cable Loss	Preamp Factor	Antenna Factor	Remark	T/Pos	A/Pos	Pol/Phase
	MHz	dBuV/m	dBuV/m	dB	dBuV	dB	dB	dB/m		deg	cm	
1 a	15539.76	39.92	54.00	-14.08	28.37	7.85	34.79	38.49	Average	162	100	VERTICAL
2 p	15539.99	52.69	74.00	-21.31	41.14	7.85	34.79	38.49	Peak	162	100	VERTICAL



<b>Temperature</b>	20°C	<b>Humidity</b>	63%
<b>Test Engineer</b>	Serway Li	<b>Configurations</b>	IEEE 802.11a Ch 40 / Chain 1
<b>Test Date</b>	Mar. 16, 2013		

**Horizontal**

	Freq	Level	Limit Line	Over Limit	Read Level	Cable Loss	Preamp Factor	Antenna Factor	Remark	T/Pos	A/Pos	Pol/Phase
	MHz	dBuV/m	dBuV/m	dB	dBuV	dB	dB	dB/m		deg	cm	
1 p	15600.24	52.96	74.00	-21.04	41.46	7.88	34.86	38.48	Peak	179	100	HORIZONTAL
2 a	15600.34	40.04	54.00	-13.96	28.54	7.88	34.86	38.48	Average	179	100	HORIZONTAL

**Vertical**

	Freq	Level	Limit Line	Over Limit	Read Level	Cable Loss	Preamp Factor	Antenna Factor	Remark	T/Pos	A/Pos	Pol/Phase
	MHz	dBuV/m	dBuV/m	dB	dBuV	dB	dB	dB/m		deg	cm	
1 p	15600.05	52.90	74.00	-21.10	41.40	7.88	34.86	38.48	Peak	327	100	VERTICAL
2 a	15600.32	40.62	54.00	-13.38	29.12	7.88	34.86	38.48	Average	327	100	VERTICAL



<b>Temperature</b>	20°C	<b>Humidity</b>	63%
<b>Test Engineer</b>	Serway Li	<b>Configurations</b>	IEEE 802.11a Ch 48 / Chain 1
<b>Test Date</b>	Mar. 16, 2013		

**Horizontal**

	Freq	Level	Limit Line	Over Limit	Read Level	Cable Loss	Preamp Factor	Antenna Factor	Remark	T/Pos	A/Pos	Pol/Phase
	MHz	dBuV/m	dBuV/m	dB	dBuV	dB	dB	dB/m		deg	cm	
1 p	15719.86	53.58	74.00	-20.42	42.14	7.92	34.94	38.46	Peak	255	100	HORIZONTAL
2 a	15720.16	40.35	54.00	-13.65	28.91	7.92	34.94	38.46	Average	255	100	HORIZONTAL

**Vertical**

	Freq	Level	Limit Line	Over Limit	Read Level	Cable Loss	Preamp Factor	Antenna Factor	Remark	T/Pos	A/Pos	Pol/Phase
	MHz	dBuV/m	dBuV/m	dB	dBuV	dB	dB	dB/m		deg	cm	
1 p	15719.53	53.21	74.00	-20.79	41.77	7.92	34.94	38.46	Peak	124	100	VERTICAL
2 a	15719.62	40.21	54.00	-13.79	28.77	7.92	34.94	38.46	Average	124	100	VERTICAL



<b>Temperature</b>	20°C	<b>Humidity</b>	63%
<b>Test Engineer</b>	Serway Li	<b>Configurations</b>	IEEE 802.11a Ch 52 / Chain 1
<b>Test Date</b>	Mar. 16, 2013		

**Horizontal**

	Freq	Level	Limit Line	Over Limit	Read Level	Cable Loss	Preamp Factor	Antenna Factor	Remark	T/Pos	A/Pos	Pol/Phase
	MHz	dBuV/m	dBuV/m	dB	dBuV	dB	dB	dB/m		deg	cm	
1 a	15779.71	41.92	54.00	-12.08	30.56	7.93	35.01	38.44	Average	98	100	HORIZONTAL
2 p	15779.88	54.21	74.00	-19.79	42.85	7.93	35.01	38.44	Peak	98	100	HORIZONTAL

**Vertical**

	Freq	Level	Limit Line	Over Limit	Read Level	Cable Loss	Preamp Factor	Antenna Factor	Remark	T/Pos	A/Pos	Pol/Phase
	MHz	dBuV/m	dBuV/m	dB	dBuV	dB	dB	dB/m		deg	cm	
1 a	15779.81	40.99	54.00	-13.01	29.63	7.93	35.01	38.44	Average	233	100	VERTICAL
2 p	15779.83	53.41	74.00	-20.59	42.05	7.93	35.01	38.44	Peak	233	100	VERTICAL



<b>Temperature</b>	20°C	<b>Humidity</b>	63%
<b>Test Engineer</b>	Serway Li	<b>Configurations</b>	IEEE 802.11a Ch 60 / Chain 1
<b>Test Date</b>	Mar. 16, 2013		

**Horizontal**

	Freq	Level	Limit Line	Over Limit	Read Level	Cable Loss	Preamp Factor	Antenna Factor	Remark	T/Pos	A/Pos	Pol/Phase
	MHz	dBuV/m	dBuV/m	dB	dBuV	dB	dB	dB/m		deg	cm	
1 p	10600.01	51.73	74.00	-22.27	41.77	6.60	35.12	38.48	Peak	112	121	HORIZONTAL
2 a	10600.01	40.94	54.00	-13.06	30.98	6.60	35.12	38.48	Average	112	121	HORIZONTAL

**Vertical**

	Freq	Level	Limit Line	Over Limit	Read Level	Cable Loss	Preamp Factor	Antenna Factor	Remark	T/Pos	A/Pos	Pol/Phase
	MHz	dBuV/m	dBuV/m	dB	dBuV	dB	dB	dB/m		deg	cm	
1 p	10600.64	52.27	74.00	-21.73	42.31	6.60	35.12	38.48	Peak	161	130	VERTICAL
2 a	10600.87	39.26	54.00	-14.74	29.28	6.60	35.10	38.48	Average	161	130	VERTICAL



<b>Temperature</b>	20°C	<b>Humidity</b>	63%
<b>Test Engineer</b>	Serway Li	<b>Configurations</b>	IEEE 802.11a Ch 64 / Chain 1
<b>Test Date</b>	Mar. 16, 2013		

**Horizontal**

	Freq	Level	Limit Line	Over Limit	Read Level	Cable Loss	Preamp Factor	Antenna Factor	Remark	T/Pos	A/Pos	Pol/Phase
	MHz	dBuV/m	dBuV/m	dB	dBuV	dB	dB	dB/m		deg	cm	
1 a	10639.94	37.28	54.00	-16.72	27.30	6.59	35.08	38.47	Average	144	100	HORIZONTAL
2 p	10639.94	50.07	74.00	-23.93	40.09	6.59	35.08	38.47	Peak	144	100	HORIZONTAL

**Vertical**

	Freq	Level	Limit Line	Over Limit	Read Level	Cable Loss	Preamp Factor	Antenna Factor	Remark	T/Pos	A/Pos	Pol/Phase
	MHz	dBuV/m	dBuV/m	dB	dBuV	dB	dB	dB/m		deg	cm	
1 p	10640.18	50.25	74.00	-23.75	40.27	6.59	35.08	38.47	Peak	245	100	VERTICAL
2 a	10640.24	37.46	54.00	-16.54	27.48	6.59	35.08	38.47	Average	245	100	VERTICAL



<b>Temperature</b>	20°C	<b>Humidity</b>	63%
<b>Test Engineer</b>	Serway Li	<b>Configurations</b>	IEEE 802.11a Ch 100 / Chain 1
<b>Test Date</b>	Mar. 16, 2013		

**Horizontal**

	Freq	Level	Limit Line	Over Limit	Read Level	Cable Loss	Preamp Factor	Antenna Factor	Remark	T/Pos	A/Pos	Pol/Phase
	MHz	dBuV/m	dBuV/m	dB	dBuV	dB	dB	dB/m		deg	cm	
1 p	10999.77	50.74	74.00	-23.26	40.69	6.46	34.81	38.40	Peak	83	100	HORIZONTAL
2 a	10999.91	38.05	54.00	-15.95	28.00	6.46	34.81	38.40	Average	83	100	HORIZONTAL

**Vertical**

	Freq	Level	Limit Line	Over Limit	Read Level	Cable Loss	Preamp Factor	Antenna Factor	Remark	T/Pos	A/Pos	Pol/Phase
	MHz	dBuV/m	dBuV/m	dB	dBuV	dB	dB	dB/m		deg	cm	
1 a	11000.11	38.54	54.00	-15.46	28.49	6.46	34.81	38.40	Average	219	100	VERTICAL
2 p	11000.27	50.24	74.00	-23.76	40.19	6.46	34.81	38.40	Peak	219	100	VERTICAL



<b>Temperature</b>	20°C	<b>Humidity</b>	63%
<b>Test Engineer</b>	Serway Li	<b>Configurations</b>	IEEE 802.11a Ch 116 / Chain 1
<b>Test Date</b>	Mar. 16, 2013		

**Horizontal**

	Freq	Level	Limit Line	Over Limit	Read Level	Cable Loss	Preamp Factor	Antenna Factor	Remark	T/Pos	A/Pos	Pol/Phase
	MHz	dBuV/m	dBuV/m	dB	dBuV	dB	dB	dB/m		deg	cm	
1 a	11159.92	41.20	54.00	-12.80	31.02	6.56	34.81	38.43	Average	129	116	HORIZONTAL
2 p	11160.84	54.82	74.00	-19.18	44.64	6.56	34.81	38.43	Peak	129	116	HORIZONTAL

**Vertical**

	Freq	Level	Limit Line	Over Limit	Read Level	Cable Loss	Preamp Factor	Antenna Factor	Remark	T/Pos	A/Pos	Pol/Phase
	MHz	dBuV/m	dBuV/m	dB	dBuV	dB	dB	dB/m		deg	cm	
1 p	11156.44	57.76	74.00	-16.24	47.59	6.55	34.81	38.43	Peak	3	100	VERTICAL
2 a	11159.20	44.93	54.00	-9.07	34.75	6.56	34.81	38.43	Average	3	100	VERTICAL





<b>Temperature</b>	20°C	<b>Humidity</b>	63%
<b>Test Engineer</b>	Serway Li	<b>Configurations</b>	IEEE 802.11a Ch 140 / Chain 1
<b>Test Date</b>	Mar. 16, 2013		

**Horizontal**

	Freq	Level	Limit Line	Over Limit	Read Level	Cable Loss	Preamp Factor	Antenna Factor	Remark	T/Pos	A/Pos	Pol/Phase
	MHz	dBuV/m	dBuV/m	dB	dBuV	dB	dB	dB/m		deg	cm	
1 p	11391.04	51.11	74.00	-22.89	40.77	6.68	34.82	38.48	Peak	151	100	HORIZONTAL
2 a	11391.44	38.41	54.00	-15.59	28.07	6.68	34.82	38.48	Average	151	100	HORIZONTAL

**Vertical**

	Freq	Level	Limit Line	Over Limit	Read Level	Cable Loss	Preamp Factor	Antenna Factor	Remark	T/Pos	A/Pos	Pol/Phase
	MHz	dBuV/m	dBuV/m	dB	dBuV	dB	dB	dB/m		deg	cm	
1 p	11399.85	51.73	74.00	-22.27	41.38	6.69	34.82	38.48	Peak	287	122	VERTICAL
2 a	11399.93	38.81	54.00	-15.19	28.46	6.69	34.82	38.48	Average	287	122	VERTICAL

**Note:**

The amplitude of spurious emissions that are attenuated by more than 20dB below the permissible value has no need to be reported.

Emission level (dBuV/m) = 20 log Emission level (uV/m).

Corrected Reading: Antenna Factor + Cable Loss + Read Level - Preamp Factor = Level.

## 4.7. Band Edge Emissions Measurement

### 4.7.1. Limit

For transmitters operating in the 5.15-5.35 GHz band: all emissions outside of the 5.15-5.35 GHz band shall not exceed a -27dBm peak limit or average and peak limits of 15.209. For transmitters operating in the 5.470-5.725 GHz band: all emissions outside of the 5.470-5.725 GHz band shall not exceed a -27dBm peak limit or average and peak limits of 15.209. In addition, In case the emission fall within the restricted band specified on 15.205(a), then the 15.209(a) limit in the table below has to be followed.

Frequencies (MHz)	Field Strength (micovolts/meter)	Measurement Distance (meters)
0.009~0.490	2400/F(KHz)	300
0.490~1.705	24000/F(KHz)	30
1.705~30.0	30	30
30~88	100	3
88~216	150	3
216~960	200	3
Above 960	500	3

### 4.7.2. Measuring Instruments and Setting

Please refer to section 5 of equipments list in this report. The following table is the setting of the spectrum analyzer.

Spectrum Parameter	Setting
Attenuation	Auto
Span Frequency	100 MHz
RB / VB (Emission in restricted band)	1 MHz / 3MHz for Peak, 1 MHz / 10Hz for Average
RB / VB (Emission in non-restricted band)	1 MHz / 3MHz for Peak

### 4.7.3. Test Procedures

- The test procedure is the same as section 4.6.3, only the frequency range investigated is limited to 100MHz around bandedges.

### 4.7.4. Test Setup Layout

This test setup layout is the same as that shown in section 4.6.4.

### 4.7.5. Test Deviation

There is no deviation with the original standard.

#### 4.7.6. Test Result of Band Edge and Fundamental Emissions

Temperature	20°C	Humidity	63%
Test Engineer	Serway Li	Configurations	IEEE 802.11n MCS0 20MHz Ch 36, 40, 48 / Chain 1 + Chain 2 + Chain 3
Test Date	Mar. 16, 2013		

##### Channel 36

	Freq	Level	Limit	Over	Read	Cable	Preamp	Antenna	Remark	T/Pos	A/Pos	Pol/Phase	
	MHz	dBuV/m	dBuV/m	dB	dBuV	dB	dB	dB/m		deg	cm		
1	5150.00	66.12	74.00	-7.88	28.64	4.34	0.00	33.14	Peak	90	154	HORIZONTAL	
2	!	5150.00	53.36	54.00	-0.64	15.88	4.34	0.00	33.14	Average	90	154	HORIZONTAL
3	p	5185.00	114.21		76.66	4.36	0.00	33.19	Peak	90	154	HORIZONTAL	
4	a	5185.00	105.28		67.73	4.36	0.00	33.19	Average	90	154	HORIZONTAL	

Item 3, 4 are the fundamental frequency at 5180 MHz.

##### Channel 40

	Freq	Level	Limit	Over	Read	Cable	Preamp	Antenna	Remark	T/Pos	A/Pos	Pol/Phase	
	MHz	dBuV/m	dBuV/m	dB	dBuV	dB	dB	dB/m		deg	cm		
1	5124.00	62.90	74.00	-11.10	25.46	4.33	0.00	33.11	Peak	89	154	HORIZONTAL	
2	!	5124.00	53.12	54.00	-0.88	15.68	4.33	0.00	33.11	Average	89	154	HORIZONTAL
3	p	5204.00	115.78		78.19	4.37	0.00	33.22	Peak	89	154	HORIZONTAL	
4	a	5205.00	105.47		67.88	4.37	0.00	33.22	Average	89	154	HORIZONTAL	

Item 3, 4 are the fundamental frequency at 5200 MHz.

##### Channel 48

	Freq	Level	Limit	Over	Read	Cable	Preamp	Antenna	Remark	T/Pos	A/Pos	Pol/Phase	
	MHz	dBuV/m	dBuV/m	dB	dBuV	dB	dB	dB/m		deg	cm		
1	5077.00	62.26	74.00	-11.74	24.93	4.30	0.00	33.03	Peak	102	136	HORIZONTAL	
2	!	5083.00	52.45	54.00	-1.55	15.12	4.30	0.00	33.03	Average	102	136	HORIZONTAL
3	p	5243.00	116.38		78.68	4.40	0.00	33.30	Peak	102	136	HORIZONTAL	
4	a	5243.00	106.99		69.29	4.40	0.00	33.30	Average	102	136	HORIZONTAL	
5	5353.00	60.21	74.00	-13.79	22.28	4.47	0.00	33.46	Peak	102	136	HORIZONTAL	
6	!	5353.00	49.01	54.00	-4.99	11.08	4.47	0.00	33.46	Average	102	136	HORIZONTAL

Item 3, 4 are the fundamental frequency at 5240 MHz.

<b>Temperature</b>	20°C	<b>Humidity</b>	63%
<b>Test Engineer</b>	Serway Li	<b>Configurations</b>	IEEE 802.11n MCS0 20MHz Ch 52, 60, 64 / Chain 1 + Chain 2 + Chain 3
<b>Test Date</b>	Mar. 16, 2013		

**Channel 52**

	Freq	Level	Limit	Over	Read	Cable	Preamp	Antenna	Remark	T/Pos	A/Pos	Pol/Phase
	MHz	dBuV/m	dBuV/m	dB	dBuV	dB	dB	dB/m		deg	cm	
1	5101.00	61.28	74.00	-12.72	23.91	4.31	0.00	33.06	Peak	110	140	HORIZONTAL
2 !	5101.00	50.40	54.00	-3.60	13.03	4.31	0.00	33.06	Average	110	140	HORIZONTAL
3 a	5256.00	109.95			72.25	4.40	0.00	33.30	Average	110	140	HORIZONTAL
4 p	5257.00	118.89			81.19	4.40	0.00	33.30	Peak	110	140	HORIZONTAL
5	5356.00	60.99	74.00	-13.01	23.06	4.47	0.00	33.46	Peak	110	140	HORIZONTAL
6 !	5377.00	50.44	54.00	-3.56	12.47	4.48	0.00	33.49	Average	110	140	HORIZONTAL

Item 3, 4 are the fundamental frequency at 5260 MHz.

**Channel 60**

	Freq	Level	Limit	Over	Read	Cable	Preamp	Antenna	Remark	T/Pos	A/Pos	Pol/Phase
	MHz	dBuV/m	dBuV/m	dB	dBuV	dB	dB	dB/m		deg	cm	
1 p	5296.00	115.29			77.47	4.44	0.00	33.38	Peak	114	152	HORIZONTAL
2 a	5296.00	104.15			66.33	4.44	0.00	33.38	Average	114	152	HORIZONTAL
3 !	5376.00	53.40	54.00	-0.60	15.43	4.48	0.00	33.49	Average	114	152	HORIZONTAL
4	5386.00	64.53	74.00	-9.47	26.53	4.49	0.00	33.51	Peak	114	152	HORIZONTAL

Item 1, 2 are the fundamental frequency at 5300 MHz.

**Channel 64**

	Freq	Level	Limit	Over	Read	Cable	Preamp	Antenna	Remark	T/Pos	A/Pos	Pol/Phase
	MHz	dBuV/m	dBuV/m	dB	dBuV	dB	dB	dB/m		deg	cm	
1 p	5316.00	115.63			77.77	4.45	0.00	33.41	Peak	110	140	HORIZONTAL
2 a	5316.00	105.07			67.21	4.45	0.00	33.41	Average	110	140	HORIZONTAL
3 !	5351.00	71.44	74.00	-2.56	33.51	4.47	0.00	33.46	Peak	110	140	HORIZONTAL
4 !	5396.00	53.22	54.00	-0.78	15.18	4.50	0.00	33.54	Average	110	140	HORIZONTAL

Item 1, 2 are the fundamental frequency at 5320 MHz.

<b>Temperature</b>	20°C	<b>Humidity</b>	63%
<b>Test Engineer</b>	Serway Li	<b>Configurations</b>	IEEE 802.11n MCS0 20MHz Ch 100, 116, 140 / Chain 1 + Chain 2 + Chain 3
<b>Test Date</b>	Mar. 16, 2013		

**Channel 100**

	Freq	Level	Limit	Over	Read	Cable	Antenna	Preamp	Remark	A/Pos	T/Pos	Pol/Phase
	MHz	dBuV/m	dBuV/m	dB	dBuV	Loss	Factor	Factor		cm	deg	
1	5416.00	53.57	54.00	-0.43	12.85	6.16	34.56	0.00	Average	147	102	HORIZONTAL
2	5416.40	64.71	74.00	-9.29	23.99	6.16	34.56	0.00	Peak	147	102	HORIZONTAL
3	5468.80	60.35	74.00	-13.65	19.48	6.20	34.67	0.00	Peak	147	102	HORIZONTAL
4	5470.00	47.23	54.00	-6.77	6.36	6.20	34.67	0.00	Average	147	102	HORIZONTAL
5	5496.00	100.77			59.86	6.21	34.70	0.00	Average	147	102	HORIZONTAL
6	5496.00	111.16			70.25	6.21	34.70	0.00	Peak	147	102	HORIZONTAL

Item 5, 6 are the fundamental frequency at 5500 MHz.

**Channel 116**

	Freq	Level	Limit	Over	Read	Cable	Preamp	Antenna	Remark	T/Pos	A/Pos	Pol/Phase
	MHz	dBuV/m	dBuV/m	dB	dBuV	Loss	Factor	Factor		deg	cm	
1	5168.00	65.20	74.00	-8.80	27.68	4.35	0.00	33.17	Peak	106	148	HORIZONTAL
2	5214.00	53.54	54.00	-0.46	15.91	4.38	0.00	33.25	Average	106	148	HORIZONTAL
3	5466.00	59.53	74.00	-14.47	21.33	4.55	0.00	33.65	Peak	106	148	HORIZONTAL
4	5466.00	49.82	54.00	-4.18	11.62	4.55	0.00	33.65	Average	106	148	HORIZONTAL
5	5576.00	117.63			79.10	4.62	0.00	33.91	Peak	106	148	HORIZONTAL
6	5576.00	108.78			70.25	4.62	0.00	33.91	Average	106	148	HORIZONTAL

Item 5, 6 are the fundamental frequency at 5580 MHz.

**Channel 140**

	Freq	Level	Limit	Over	Read	Cable	Preamp	Antenna	Remark	T/Pos	A/Pos	Pol/Phase
	MHz	dBuV/m	dBuV/m	dB	dBuV	Loss	Factor	Factor		deg	cm	
1	5696.00	100.53			61.56	4.70	0.00	34.27	Average	218	147	HORIZONTAL
2	5696.40	110.77			71.80	4.70	0.00	34.27	Peak	218	147	HORIZONTAL
3	5725.00	69.12	74.00	-4.88	30.03	4.72	0.00	34.37	Peak	218	147	HORIZONTAL
4	5725.80	53.56	54.00	-0.44	14.47	4.72	0.00	34.37	Average	218	147	HORIZONTAL

Item 1, 2 are the fundamental frequency at 5700 MHz.

<b>Temperature</b>	20°C	<b>Humidity</b>	63%
<b>Test Engineer</b>	Serway Li	<b>Configurations</b>	IEEE 802.11n MCS0 40MHz Ch 38, 46 / Chain 1 + Chain 2 + Chain 3
<b>Test Date</b>	Mar. 16, 2013		

**Channel 38**

	Freq	Level	Limit	Over	Read	Cable	Preamp	Antenna	Remark	T/Pos	A/Pos	Pol/Phase
	MHz	dBuV/m	dBuV/m	dB	dBuV	dB	dB	dB/m		deg	cm	
1	5149.60	53.75	54.00	-0.25	16.27	4.34	0.00	33.14	Average	89	151	HORIZONTAL
2	5150.00	67.74	74.00	-6.26	30.26	4.34	0.00	33.14	Peak	89	151	HORIZONTAL
3 p	5179.60	107.32			69.77	4.36	0.00	33.19	Peak	89	151	HORIZONTAL
4 a	5194.80	95.89			58.30	4.37	0.00	33.22	Average	89	151	HORIZONTAL

Item 3, 4 are the fundamental frequency at 5190 MHz.

**Channel 46**

	Freq	Level	Limit	Over	Read	Cable	Preamp	Antenna	Remark	T/Pos	A/Pos	Pol/Phase
	MHz	dBuV/m	dBuV/m	dB	dBuV	dB	dB	dB/m		deg	cm	
1	5150.00	67.16	74.00	-6.84	29.68	4.34	0.00	33.14	Peak	123	152	HORIZONTAL
2	5150.00	53.69	54.00	-0.31	16.21	4.34	0.00	33.14	Average	123	152	HORIZONTAL
3 p	5225.00	115.15			77.49	4.39	0.00	33.27	Peak	123	152	HORIZONTAL
4 a	5229.00	105.96			68.30	4.39	0.00	33.27	Average	123	152	HORIZONTAL

Item 3, 4 are the fundamental frequency at 5230 MHz.

<b>Temperature</b>	20°C	<b>Humidity</b>	63%
<b>Test Engineer</b>	Serway Li	<b>Configurations</b>	IEEE 802.11n MCS0 40MHz Ch 54, 62 / Chain 1 + Chain 2 + Chain 3
<b>Test Date</b>	Mar. 16, 2013		

**Channel 54**

	Freq	Level	Limit	Over	Read	Cable	Preamp	Antenna	Remark	T/Pos	A/Pos	Pol/Phase
	MHz	dBuV/m	dBuV/m	dB	dBuV	dB	dB	dB/m		deg	cm	
1 a	5268.00	103.83			66.08	4.42	0.00	33.33	Average	99	150	HORIZONTAL
2 p	5273.00	115.20			77.45	4.42	0.00	33.33	Peak	99	150	HORIZONTAL
3 !	5353.00	69.80	74.00	-4.20	31.87	4.47	0.00	33.46	Peak	99	150	HORIZONTAL
4 !	5353.00	53.43	54.00	-0.57	15.50	4.47	0.00	33.46	Average	99	150	HORIZONTAL

Item 1, 2 are the fundamental frequency at 5270 MHz.

**Channel 62**

	Freq	Level	Limit	Over	Read	Cable	Preamp	Antenna	Remark	T/Pos	A/Pos	Pol/Phase
	MHz	dBuV/m	dBuV/m	dB	dBuV	dB	dB	dB/m		deg	cm	
1 p	5311.20	109.04			71.18	4.45	0.00	33.41	Peak	111	143	HORIZONTAL
2 a	5311.20	97.13			59.27	4.45	0.00	33.41	Average	111	143	HORIZONTAL
3	5350.80	66.70	74.00	-7.30	28.77	4.47	0.00	33.46	Peak	111	143	HORIZONTAL
4 !	5351.20	53.28	54.00	-0.72	15.35	4.47	0.00	33.46	Average	111	143	HORIZONTAL

Item 1, 2 are the fundamental frequency at 5310 MHz.





<b>Temperature</b>	20°C	<b>Humidity</b>	63%
<b>Test Engineer</b>	Serway Li	<b>Configurations</b>	IEEE 802.11n MCS0 40MHz Ch 102, 110, 134 / Chain 1 + Chain 2 + Chain 3
<b>Test Date</b>	Mar. 16, 2013		

**Channel 102**

	Freq	Level	Limit Line	Over Limit	Read Level	Cable Loss	Preamp Factor	Antenna Factor	Remark	T/Pos	A/Pos	Pol/Phase
	MHz	dBuV/m	dBuV/m	dB	dBuV	dB	dB	dB/m		deg	cm	
1	5459.60	62.36	74.00	-11.64	24.20	4.54	0.00	33.62	Peak	109	149	HORIZONTAL
2 !	5460.00	48.28	54.00	-5.72	10.12	4.54	0.00	33.62	Average	109	149	HORIZONTAL
3 !	5466.40	69.00	74.00	-5.00	30.80	4.55	0.00	33.65	Peak	109	149	HORIZONTAL
4 !	5470.00	53.63	54.00	-0.37	15.43	4.55	0.00	33.65	Average	109	149	HORIZONTAL
5 p	5511.20	108.07			69.80	4.57	0.00	33.70	Peak	109	149	HORIZONTAL
6 a	5511.20	95.99			57.72	4.57	0.00	33.70	Average	109	149	HORIZONTAL

Item 5, 6 are the fundamental frequency at 5510MHz.

**Channel 110**

	Freq	Level	Limit Line	Over Limit	Read Level	Cable Loss	Preamp Factor	Antenna Factor	Remark	T/Pos	A/Pos	Pol/Phase
	MHz	dBuV/m	dBuV/m	dB	dBuV	dB	dB	dB/m		deg	cm	
1	5376.00	64.03	74.00	-9.97	26.06	4.48	0.00	33.49	Peak	108	148	HORIZONTAL
2 !	5391.00	53.33	54.00	-0.67	15.33	4.49	0.00	33.51	Average	108	148	HORIZONTAL
3 !	5466.00	52.55	54.00	-1.45	14.35	4.55	0.00	33.65	Average	108	148	HORIZONTAL
4	5470.00	66.17	74.00	-7.83	27.97	4.55	0.00	33.65	Peak	108	148	HORIZONTAL
5 p	5551.00	115.54			77.08	4.60	0.00	33.86	Peak	108	148	HORIZONTAL
6 a	5551.00	103.74			65.28	4.60	0.00	33.86	Average	108	148	HORIZONTAL

Item 5, 6 are the fundamental frequency at 5550 MHz.

**Channel 134**

	Freq	Level	Limit Line	Over Limit	Read Level	Cable Loss	Preamp Factor	Antenna Factor	Remark	T/Pos	A/Pos	Pol/Phase
	MHz	dBuV/m	dBuV/m	dB	dBuV	dB	dB	dB/m		deg	cm	
1 a	5670.80	101.75			62.85	4.68	0.00	34.22	Average	106	143	HORIZONTAL
2 p	5671.60	113.49			74.59	4.68	0.00	34.22	Peak	106	143	HORIZONTAL
3 !	5725.80	53.75	54.00	-0.25	14.66	4.72	0.00	34.37	Average	106	143	HORIZONTAL
4 !	5726.20	71.83	74.00	-2.17	32.74	4.72	0.00	34.37	Peak	106	143	HORIZONTAL

Item 1, 2 are the fundamental frequency at 5670 MHz.

Note:

Emission level (dBuV/m) = 20 log Emission level (uV/m)

Corrected Reading: Antenna Factor + Cable Loss + Read Level - Preamp Factor = Level





Temperature	20°C	Humidity	63%
Test Engineer	Serway Li	Configurations	IEEE 802.11a Ch 36, 40, 48 / Chain 1
Test Date	Mar. 16, 2013		

**Channel 36**

	Freq	Level	Limit Line	Over Limit	Read Level	Cable Loss	Preamp Factor	Antenna Factor	Remark	T/Pos	A/Pos	Pol/Phase
	MHz	dBuV/m	dBuV/m	dB	dBuV	dB	dB	dB/m		deg	cm	
1 !	5149.60	71.98	74.00	-2.02	34.50	4.34	0.00	33.14	Peak	93	154	HORIZONTAL
2 !	5150.00	53.14	54.00	-0.86	15.66	4.34	0.00	33.14	Average	93	154	HORIZONTAL
3 p	5176.80	112.09			74.54	4.36	0.00	33.19	Peak	93	154	HORIZONTAL
4 a	5183.60	100.53			62.98	4.36	0.00	33.19	Average	93	154	HORIZONTAL

Item 3, 4 are the fundamental frequency at 5180 MHz.

**Channel 40**

	Freq	Level	Limit Line	Over Limit	Read Level	Cable Loss	Preamp Factor	Antenna Factor	Remark	T/Pos	A/Pos	Pol/Phase
	MHz	dBuV/m	dBuV/m	dB	dBuV	dB	dB	dB/m		deg	cm	
1	5148.40	62.74	74.00	-11.26	25.26	4.34	0.00	33.14	Peak	248	141	HORIZONTAL
2 !	5150.00	48.74	54.00	-5.26	11.26	4.34	0.00	33.14	Average	248	141	HORIZONTAL
3 a	5204.00	101.46			63.87	4.37	0.00	33.22	Average	248	141	HORIZONTAL
4 p	5204.40	113.18			75.59	4.37	0.00	33.22	Peak	248	141	HORIZONTAL

Item 3, 4 are the fundamental frequency at 5200 MHz.

**Channel 48**

	Freq	Level	Limit Line	Over Limit	Read Level	Cable Loss	Preamp Factor	Antenna Factor	Remark	T/Pos	A/Pos	Pol/Phase
	MHz	dBuV/m	dBuV/m	dB	dBuV	dB	dB	dB/m		deg	cm	
1	5148.00	44.69	54.00	-9.31	7.21	4.34	0.00	33.14	Average	248	138	HORIZONTAL
2	5149.00	58.12	74.00	-15.88	20.64	4.34	0.00	33.14	Peak	248	138	HORIZONTAL
3 a	5244.00	100.90			63.20	4.40	0.00	33.30	Average	248	138	HORIZONTAL
4 p	5245.00	111.59			73.89	4.40	0.00	33.30	Peak	248	138	HORIZONTAL
5	5353.00	44.22	54.00	-9.78	6.29	4.47	0.00	33.46	Average	248	138	HORIZONTAL
6	5354.00	56.29	74.00	-17.71	18.36	4.47	0.00	33.46	Peak	248	138	HORIZONTAL

Item 3, 4 are the fundamental frequency at 5240 MHz.



Temperature	20°C	Humidity	63%
Test Engineer	Serway Li	Configurations	IEEE 802.11a Ch 52, 60, 64 / Chain 1
Test Date	Mar. 16, 2013		

**Channel 52**

	Freq	Level	Limit Line	Over Limit	Read Level	Cable Loss	Preamp Factor	Antenna Factor	Remark	T/Pos	A/Pos	Pol/Phase
	MHz	dBuV/m	dBuV/m	dB	dBuV	dB	dB	dB/m		deg	cm	
1	5147.00	46.92	54.00	-7.08	9.44	4.34	0.00	33.14	Average	252	145	HORIZONTAL
2	5148.00	59.52	74.00	-14.48	22.04	4.34	0.00	33.14	Peak	252	145	HORIZONTAL
3 a	5256.00	102.41			64.71	4.40	0.00	33.30	Average	252	145	HORIZONTAL
4 p	5262.00	114.03			76.28	4.42	0.00	33.33	Peak	252	145	HORIZONTAL
5	5359.00	60.31	74.00	-13.69	22.38	4.47	0.00	33.46	Peak	252	145	HORIZONTAL
6	5373.00	45.72	54.00	-8.28	7.75	4.48	0.00	33.49	Average	252	145	HORIZONTAL

Item 3, 4 are the fundamental frequency at 5260 MHz.

**Channel 60**

	Freq	Level	Limit Line	Over Limit	Read Level	Cable Loss	Preamp Factor	Antenna Factor	Remark	T/Pos	A/Pos	Pol/Phase
	MHz	dBuV/m	dBuV/m	dB	dBuV	dB	dB	dB/m		deg	cm	
1 p	5296.00	114.16			76.34	4.44	0.00	33.38	Peak	122	148	HORIZONTAL
2 a	5303.60	102.30			64.48	4.44	0.00	33.38	Average	122	148	HORIZONTAL
3 !	5350.00	49.15	54.00	-4.85	11.22	4.47	0.00	33.46	Average	122	148	HORIZONTAL
4	5352.00	64.41	74.00	-9.59	26.48	4.47	0.00	33.46	Peak	122	148	HORIZONTAL

Item 1, 2 are the fundamental frequency at 5300 MHz.

**Channel 64**

	Freq	Level	Limit Line	Over Limit	Read Level	Cable Loss	Preamp Factor	Antenna Factor	Remark	T/Pos	A/Pos	Pol/Phase
	MHz	dBuV/m	dBuV/m	dB	dBuV	dB	dB	dB/m		deg	cm	
1 p	5316.20	112.09			74.23	4.45	0.00	33.41	Peak	114	138	HORIZONTAL
2 a	5323.20	100.39			62.53	4.45	0.00	33.41	Average	114	138	HORIZONTAL
3 !	5350.00	53.14	54.00	-0.86	15.21	4.47	0.00	33.46	Average	114	138	HORIZONTAL
4 !	5352.20	73.68	74.00	-0.32	35.75	4.47	0.00	33.46	Peak	114	138	HORIZONTAL

Item 1, 2 are the fundamental frequency at 5320 MHz



<b>Temperature</b>	20°C	<b>Humidity</b>	63%
<b>Test Engineer</b>	Serway Li	<b>Configurations</b>	IEEE 802.11a Ch 100, 140 / Chain 1
<b>Test Date</b>	Mar. 16, 2013		

**Channel 100**

	Freq	Level	Limit Line	Over Limit	Read Level	Cable Loss	Preamp Factor	Antenna Factor	Remark	T/Pos	A/Pos	Pol/Phase
	MHz	dBuV/m	dBuV/m	dB	dBuV	dB	dB	dB/m		deg	cm	
1 !	5422.40	49.53	54.00	-4.47	11.44	4.52	0.00	33.57	Average	115	147	HORIZONTAL
2	5457.60	64.78	74.00	-9.22	26.62	4.54	0.00	33.62	Peak	115	147	HORIZONTAL
3 !	5466.80	70.89	74.00	-3.11	32.69	4.55	0.00	33.65	Peak	115	147	HORIZONTAL
4 !	5470.00	53.29	54.00	-0.71	15.09	4.55	0.00	33.65	Average	115	147	HORIZONTAL
5 p	5502.80	110.34			72.07	4.57	0.00	33.70	Peak	115	147	HORIZONTAL
6 a	5503.60	99.40			61.13	4.57	0.00	33.70	Average	115	147	HORIZONTAL

Item 5, 6 are the fundamental frequency at 5500 MHz.

**Channel 140**

	Freq	Level	Limit Line	Over Limit	Read Level	Cable Loss	Preamp Factor	Antenna Factor	Remark	T/Pos	A/Pos	Pol/Phase
	MHz	dBuV/m	dBuV/m	dB	dBuV	dB	dB	dB/m		deg	cm	
1 a	5692.40	97.64			58.67	4.70	0.00	34.27	Average	102	137	HORIZONTAL
2 p	5695.60	109.43			70.46	4.70	0.00	34.27	Peak	102	137	HORIZONTAL
3 !	5725.00	53.38	54.00	-0.62	14.29	4.72	0.00	34.37	Average	102	137	HORIZONTAL
4 !	5725.40	70.25	74.00	-3.75	31.16	4.72	0.00	34.37	Peak	102	137	HORIZONTAL

Item 1, 2 are the fundamental frequency at 5700 MHz.

Note:

Emission level (dBuV/m) = 20 log Emission level (uV/m)

Corrected Reading: Antenna Factor + Cable Loss + Read Level - Preamp Factor = Level

## 4.8. Frequency Stability Measurement

### 4.8.1. Limit

Manufacturers of U-NII devices are responsible for ensuring frequency stability such that an emissions is maintained within the band of operation under all conditions of normal operation as specified in the user's manual or  $\pm 20\text{ppm}$  (IEEE 802.11 specification).

### 4.8.2. Measuring Instruments and Setting

Please refer to section 5 of equipments list in this report. The following table is the setting of the spectrum analyzer.

Spectrum Parameter	Setting
Attenuation	Auto
Span Frequency	Entire absence of modulation emissions bandwidth
RB	10 kHz
VB	10 kHz
Sweep Time	Auto

### 4.8.3. Test Procedures

1. The transmitter output (antenna port) was connected to the spectrum analyzer.
2. EUT have transmitted absence of modulation signal and fixed channelize.
3. Set the spectrum analyzer span to view the entire absence of modulation emissions bandwidth.
4. Set RBW = 10 kHz, VBW = 10 kHz with peak detector and maxhold settings.
5.  $f_c$  is declaring of channel frequency. Then the frequency error formula is  $(f_c - f) / f_c \times 10^6$  ppm and the limit is less than  $\pm 20\text{ppm}$  (IEEE 802.11 specification).
6. The test extreme voltage is to change the primary supply voltage from 85 to 115 percent of the nominal value
7. Extreme temperature rule is  $-30^\circ\text{C} \sim 50^\circ\text{C}$ .

### 4.8.4. Test Setup Layout

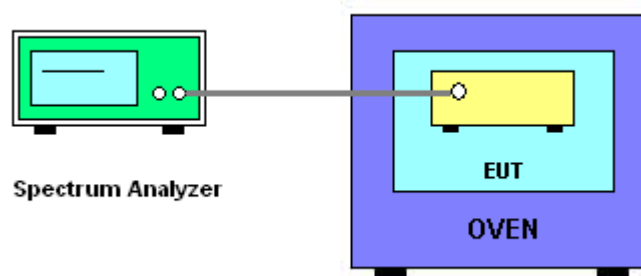

#### 4.8.5. Test Deviation

There is no deviation with the original standard.

#### 4.8.6. EUT Operation during Test

The EUT was programmed to be in continuously un-modulation transmitting mode.

#### 4.8.7. Test Result of Frequency Stability

##### Voltage vs. Frequency Stability

Voltage	Measurement Frequency (MHz)		
	5200	5300	5500
(V)			
126.50	5200.0082	5300.0064	5500.0062
110.00	5200.0060	5300.0062	5500.0044
93.50	5200.0078	5300.0080	5500.0026
Max. Deviation (MHz)	0.008200	0.008000	0.006200
Max. Deviation (ppm)	<b>1.58</b>	<b>1.51</b>	<b>1.13</b>

##### Temperature vs. Frequency Stability

Temperature	Measurement Frequency (MHz)		
	5200	5300	5500
(°C)			
-30	5199.9948	5299.9964	5499.9952
-20	5199.9940	5299.9956	5499.9948
-10	5199.9936	5299.9988	5499.9936
0	5199.9950	5299.9966	5499.9936
10	5199.9936	5299.9956	5499.9928
20	5199.9942	5299.9948	5499.9930
30	5200.0240	5300.0232	5500.0226
40	5200.0248	5300.0220	5500.0236
50	5200.0221	5300.0252	5500.0250
Max. Deviation (MHz)	0.024800	0.025200	0.025000
Max. Deviation (ppm)	<b>4.77</b>	<b>4.75</b>	<b>4.55</b>

## 4.9. Antenna Requirements

### 4.9.1. Limit

Except for special regulations, the Low-power Radio-frequency Devices must not be equipped with any jacket for installing an antenna with extension cable. An intentional radiator shall be designed to ensure that no antenna other than that furnished by the responsible party shall be used with the device. The use of a permanently attached antenna or of an antenna that uses a unique coupling to the intentional radiator shall be considered sufficient to comply with the provisions of this Section. The manufacturer may design the unit so that the user can replace a broken antenna, but the use of a standard antenna jack or electrical connector is prohibited. Further, this requirement does not apply to intentional radiators that must be professionally installed.

### 4.9.2. Antenna Connector Construction

Please refer to section 3.3 in this test report; antenna connector complied with the requirements.

## 5. LIST OF MEASURING EQUIPMENTS

Instrument	Manufacturer	Model No.	Serial No.	Characteristics	Calibration Date	Remark
BILOG ANTENNA	Schaffner	CBL6112D	22021	20MHz ~ 2GHz	Jan. 11, 2013	Radiation (03CH01-CB)
Loop Antenna	Teseq	HLA 6120	24155	9 kHz - 30 MHz	Nov. 05, 2012*	Radiation (03CH01-CB)
Horn Antenna	EMCO	3115	00075790	750MHz~18GHz	Nov. 27, 2012	Radiation (03CH01-CB)
Horn Antenna	SCHWARZBEAK	BBHA 9170	BBHA9170252	15GHz ~ 40GHz	Nov. 23, 2012	Radiation (03CH01-CB)
Pre-Amplifier	Agilent	8447D	2944A10991	0.1MHz ~ 1.3GHz	Nov. 27, 2012	Radiation (03CH01-CB)
Pre-Amplifier	Agilent	8449B	3008A02310	1GHz ~ 26.5GHz	Nov. 23, 2012	Radiation (03CH01-CB)
Pre-Amplifier	WM	TF-130N-R1	923365	26.5GHz ~ 40GHz	Jul. 31, 2012	Radiation (03CH01-CB)
Spectrum analyzer	R&S	FSP40	100056	9KHz~40GHz	Nov. 16, 2012	Radiation (03CH01-CB)
EMI Test Receiver	R&S	ESCS 30	100355	9KHz ~ 2.75GHz	Mar. 20, 2012	Radiation (03CH01-CB)
Turn Table	INN CO	CO 2000	N/A	0 ~ 360 degree	N.C.R	Radiation (03CH01-CB)
Antenna Mast	INN CO	CO2000	N/A	1 m - 4 m	N.C.R	Radiation (03CH01-CB)
RF Cable-low	Woken	Low Cable-1	N/A	30 MHz - 1 GHz	Nov. 18, 2012	Radiation (03CH01-CB)
RF Cable-high	Woken	High Cable-1	N/A	1 GHz - 26.5 GHz	Nov. 18, 2012	Radiation (03CH01-CB)
RF Cable-high	Woken	High Cable-2	N/A	1 GHz - 26.5 GHz	Nov. 18, 2012	Radiation (03CH01-CB)
RF Cable-high	Woken	High Cable-3	N/A	1 GHz - 40 GHz	Nov. 18, 2012	Radiation (03CH01-CB)
RF Cable-high	Woken	High Cable-4	N/A	1 GHz - 40 GHz	Nov. 18, 2012	Radiation (03CH01-CB)
Temp. and Humidity Chamber	Ten Billion	TTH-D3SP	TBN-931011	-30~100 degree	Jun. 05, 2012	Conducted (TH01-CB)
Signal Generator	R&S	SMR40	100302	10MHz-40GHz	Nov. 27, 2012	Conducted (TH01-CB)
RF Power Divider	Woken	2 Way	0120A02056002D	2GHz ~ 18GHz	Nov. 18, 2012	Conducted (TH01-CB)
RF Power Divider	Woken	3 Way	MDC2366	2GHz ~ 18GHz	Nov. 18, 2012	Conducted (TH01-CB)
RF Power Divider	Woken	4 Way	0120A04056002D	2GHz ~ 18GHz	Nov. 18, 2012	Conducted (TH01-CB)
RF Cable-high	Woken	High Cable-7	-	1 GHz - 26.5 GHz	Nov. 19, 2012	Conducted (TH01-CB)
RF Cable-high	Woken	High Cable-8	-	1 GHz - 26.5 GHz	Nov. 19, 2012	Conducted (TH01-CB)
RF Cable-high	Woken	High Cable-9	-	1 GHz - 26.5 GHz	Nov. 19, 2012	Conducted (TH01-CB)
RF Cable-high	Woken	High Cable-10	-	1 GHz - 26.5 GHz	Nov. 19, 2012	Conducted (TH01-CB)
RF Cable-high	Woken	High Cable-11	-	1 GHz - 26.5 GHz	Nov. 19, 2012	Conducted (TH01-CB)
Power Sensor	Anritsu	MA2411B	0917223	300MHz~40GHz	Nov. 28, 2012	Conducted (TH01-CB)
Power Meter	Anritsu	ML2495A	1035008	300MHz~40GHz	Nov. 27, 2012	Conducted (TH01-CB)

Instrument	Manufacturer	Model No.	Serial No.	Characteristics	Calibration Date	Remark
EMI Test Receiver	R&S	ESCS 30	100377	9kHz ~ 2.75GHz	Oct. 23, 2012	Conduction (CO01-CB)
LISN	F.C.C.	FCC-LISN-50-16-2	04083	150kHz ~ 100MHz	Nov. 26, 2012	Conduction (CO01-CB)
V- LISN	Schwarzbeck	NSLK 8127	8127-478	9kHz ~ 30MHz	Jun. 22, 2012	Conduction (CO01-CB)
Impulsbegrenzer Pulse Limiter	Rohde&Schwarz	ESH3-Z2	100430	9kHz~30MHz	Feb. 21, 2013	Conduction (CO01-CB)
COND Cable	Woken	Cable	01	0.15MHz~30MHz	Dec. 04, 2012	Conduction (CO01-CB)
Software	Audix	E3	5.410e	-	-	Conduction (CO01-CB)

Note: Calibration Interval of instruments listed above is one year.

“\*” Calibration Interval of instruments listed above is two years.

N.C.R. means Non-Calibration required.



## 6. TEST LOCATION

SHIJR	ADD : 6Fl., No. 106, Sec. 1, Shintai 5th Rd., Shijr City, Taipei, Taiwan 221, R.O.C. TEL : 886-2-2696-2468 FAX : 886-2-2696-2255
HWA YA	ADD : No. 52, Hwa Ya 1st Rd., Kwei-Shan Hsiang, Tao Yuan Hsien, Taiwan, R.O.C. TEL : 886-3-327-3456 FAX : 886-3-318-0055
LINKOU	ADD : No. 30-2, Dingfu Tsuen, Linkou Shiang, Taipei, Taiwan 244, R.O.C TEL : 886-2-2601-1640 FAX : 886-2-2601-1695
DUNGHU	ADD : No. 3, Lane 238, Kangle St., Neihu Chiu, Taipei, Taiwan 114, R.O.C. TEL : 886-2-2631-4739 FAX : 886-2-2631-9740
JUNGHE	ADD : 7Fl., No. 758, Jungjeng Rd., Junghe City, Taipei, Taiwan 235, R.O.C. TEL : 886-2-8227-2020 FAX : 886-2-8227-2626
NEIHU	ADD : 4Fl., No. 339, Hsin Hu 2 <sup>nd</sup> Rd., Taipei 114, Taiwan, R.O.C. TEL : 886-2-2794-8886 FAX : 886-2-2794-9777
JHUBEI	ADD : No.8, Lane 724, Bo-ai St., Jhubei City, HsinChu County 302, Taiwan, R.O.C. TEL : 886-3-656-9065 FAX : 886-3-656-9085