



SPORTON International Inc.

No. 52, Hwa Ya 1st Rd., Kwei-Shan Hsiang, TaoYuan Hsien, Taiwan, R.O.C.
Ph: 886-3-327-3456 / FAX: 886-3-327-0973 / www.sporton.com.tw

FCC RADIO TEST REPORT

Applicant's company	PEGATRON CORPORATION
Applicant Address	5F., NO. 76, LIGONG ST., BEITOU DISTRICT, TAIPEI CITY 112 Taiwan
FCC ID	VUIUPWL6031C
Manufacturer's company	PEGATRON CORPORATION
Manufacturer Address	5F., NO. 76, LIGONG ST., BEITOU DISTRICT, TAIPEI CITY 112 Taiwan

Product Name	Wireless module
Brand Name	PEGATRON
Model Name	UPWL6031C
Test Rule Part(s)	47 CFR FCC Part 15 Subpart C § 15.247
Test Freq. Range	2400 ~ 2483.5MHz / 5725 ~ 5850MHz
Received Date	Feb. 08, 2013
Final Test Date	Apr. 09, 2013
Submission Type	Original Equipment

Statement

Test result included is only for the IEEE 802.11n, IEEE 802.11b/g part and IEEE 802.11a (5725 ~ 5850MHz) of the product.

The test result in this report refers exclusively to the presented test model / sample.

Without written approval of SPORTON International Inc., the test report shall not be reproduced except in full.

The measurements and test results shown in this test report were made in accordance with the procedures and found in compliance with the limit given in ANSI C63.10-2009, 47 CFR FCC Part 15 Subpart C, KDB 558074 D01 v02 and KDB 662911 D01 v01r02.

The test equipment used to perform the test is calibrated and traceable to NML/ROC.



Table of Contents

1. CERTIFICATE OF COMPLIANCE	1
2. SUMMARY OF THE TEST RESULT	2
3. GENERAL INFORMATION	3
3.1. Product Details.....	3
3.2. Accessories.....	4
3.3. Table for Filed Antenna.....	5
3.4. Table for Carrier Frequencies	7
3.5. Table for Test Modes	8
3.6. Table for Testing Locations.....	10
3.7. Table for Supporting Units	10
3.8. Table for Parameters of Test Software Setting	11
3.9. Test Configurations	12
4. TEST RESULT	15
4.1. AC Power Line Conducted Emissions Measurement.....	15
4.2. Maximum Conducted Output Power Measurement.....	19
4.3. Power Spectral Density Measurement	22
4.4. 6dB Spectrum Bandwidth Measurement	30
4.5. Radiated Emissions Measurement	37
4.6. Emissions Measurement	63
4.7. Antenna Requirements	90
5. LIST OF MEASURING EQUIPMENTS	91
6. TEST LOCATION.....	93
APPENDIX A. TEST PHOTOS	A1 ~ A5
APPENDIX B. MAXIMUM PERMISSIBLE EXPOSURE	B1 ~ B3



History of This Test Report

REPORT NO.	VERSION	DESCRIPTION	ISSUED DATE
FR320831AA	Rev. 01	Initial issue of report	Apr. 15, 2013

1. CERTIFICATE OF COMPLIANCE

Product Name : Wireless module
Brand Name : PEGATRON
Model Name : UPWL6031C
Applicant : PEGATRON CORPORATION
Test Rule Part(s) : 47 CFR FCC Part 15 Subpart C § 15.247

Sporton International as requested by the applicant to evaluate the EMC performance of the product sample received on Feb. 08, 2013 would like to declare that the tested sample has been evaluated and found to be in compliance with the tested rule parts. The data recorded as well as the test configuration specified is true and accurate for showing the sample's EMC nature.

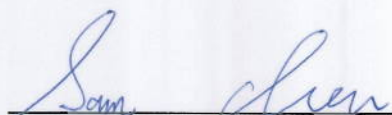

Sam Chen

SPORTON INTERNATIONAL INC.

2. SUMMARY OF THE TEST RESULT

Applied Standard: 47 CFR FCC Part 15 Subpart C				
Part	Rule Section	Description of Test	Result	Under Limit
4.1	15.207	AC Power Line Conducted Emissions	Complies	13.43 dB
4.2	15.247(b)(3)	Maximum Conducted Output Power	Complies	5.42 dB
4.3	15.247(e)	Power Spectral Density	Complies	8.42 dB
4.4	15.247(a)(2)	6dB Spectrum Bandwidth	Complies	-
4.5	15.247(d)	Radiated Emissions	Complies	0.13 dB
4.6	15.247(d)	Band Edge Emissions	Complies	0.23 dB
4.7	15.203	Antenna Requirements	Complies	-

Test Items	Uncertainty	Remark
AC Power Line Conducted Emissions	±2.3dB	Confidence levels of 95%
Maximum Conducted Output Power	±0.8dB	Confidence levels of 95%
Power Spectral Density	±0.5dB	Confidence levels of 95%
6dB Spectrum Bandwidth	±8.5×10 ⁻⁸	Confidence levels of 95%
Radiated Emissions (9kHz~30MHz)	±0.8dB	Confidence levels of 95%
Radiated Emissions (30MHz~1000MHz)	±1.9dB	Confidence levels of 95%
Radiated / Band Edge Emissions (1GHz~18GHz)	±1.9dB	Confidence levels of 95%
Radiated Emissions (18GHz~40GHz)	±1.9dB	Confidence levels of 95%
Temperature	±0.7°C	Confidence levels of 95%
Humidity	±3.2%	Confidence levels of 95%
DC / AC Power Source	±1.4%	Confidence levels of 95%

3. GENERAL INFORMATION

3.1. Product Details

IEEE 802.11n

Items	Description
Product Type	WLAN (3TX, 3RX)
Radio Type	Intentional Transceiver
Power Type	From Host System
Modulation	see the below table for IEEE 802.11n
Data Modulation	OFDM (BPSK / QPSK / 16QAM / 64QAM)
Data Rate (Mbps)	see the below table for IEEE 802.11n
Frequency Range	2400 ~ 2483.5MHz / 5725 ~ 5850MHz
Channel Number	For 2.4GHz Band: 11 for 20MHz bandwidth ; 7 for 40MHz bandwidth For 5GHz Band: 5 for 20MHz bandwidth ; 2 for 40MHz bandwidth
Channel Band Width (99%)	For 2.4GHz Band: MCS0 (20MHz): 18.80 MHz ; MCS0 (40MHz): 35.36 MHz For 5GHz Band: MCS0 (20MHz): 17.68 MHz ; MCS0 (40MHz): 36.32 MHz
Maximum Conducted Output Power	For 2.4GHz Band: MCS0 (20MHz): 24.58 dBm ; MCS0 (40MHz): 20.16 dBm For 5GHz Band: MCS0 (20MHz): 20.36 dBm ; MCS0 (40MHz): 20.04 dBm
Carrier Frequencies	Please refer to section 3.4
Antenna	Please refer to section 3.3

802.11a/b/g

Items	Description
Product Type	WLAN (1TX, 3RX)
Radio Type	Intentional Transceiver
Power Type	From Host System
Modulation	DSSS for IEEE 802.11b ; OFDM for IEEE 802.11a/g
Data Modulation	DSSS (BPSK / QPSK / CCK) ; OFDM (BPSK / QPSK / 16QAM / 64QAM)
Data Rate (Mbps)	DSSS (1/ 2/ 5.5/11) ; OFDM (6/9/12/18/24/36/48/54)
Frequency Range	2400 ~ 2483.5MHz / 5725 ~ 5850MHz
Channel Number	11b/g: 11 ; 11a: 5
Channel Band Width (99%)	11b: 10.32 MHz ; 11g: 24.80MHz ; 11a: 28.32 MHz
Maximum Conducted Output Power	11b: 19.43 dBm ; 11g: 22.11 dBm ; 11a: 21.46 dBm
Carrier Frequencies	Please refer to section 3.4
Antenna	Please refer to section 3.3

Antenna & Band width

Antenna	Single (TX)		Three (TX)	
	20 MHz	40 MHz	20 MHz	40 MHz
Band width Mode				
IEEE 802.11a	V	X	X	X
IEEE 802.11b	V	X	X	X
IEEE 802.11g	V	X	X	X
IEEE 802.11n	X	X	V	V

IEEE 11n Spec.

Protocol	Number of Transmit Chains (NTX)	Data Rate / MCS
802.11n (HT20)	3	MCS 0-23
802.11n (HT40)	3	MCS 0-23

Note 1: IEEE Std. 802.11n modulation consists of HT20 and HT40 (HT: High Throughput). Then EUT support HT20 and HT40.

Note 2: Modulation modes consist of below configuration:
HT20/HT40: IEEE 802.11n

3.2. Accessories

N/A

3.3. Table for Filed Antenna

Ant.	Brand Holder	Model Name	Antenna Type	Connector	Gain (dBi)	
					2.4GHz	5GHz
1	HL Technology	260-26021	PCB Antenna	I-PEX	3.34	-
2	HL Technology	260-26022	PCB Antenna	I-PEX	2.32	2.52
3	HL Technology	260-26023	PCB Antenna	I-PEX	4.64	2.73
4	HL Technology	260-26027	PCB Antenna	I-PEX	3.57	-
5	HL Technology	260-26028	PCB Antenna	I-PEX	2.58	-
6	HL Technology	260-26029	PCB Antenna	I-PEX	2.7	-
7	HL Technology	260-26030	PCB Antenna	I-PEX	2.06	2.68
8	HL Technology	260-26031	PCB Antenna	I-PEX	3.88	2.77
9	HL Technology	260-26032	PCB Antenna	I-PEX	3.65	2.56
10	HL Technology	260-26033	PCB Antenna	I-PEX	3.34	-
11	HL Technology	260-26034	PCB Antenna	I-PEX	2.65	-
12	HL Technology	260-26035	PCB Antenna	I-PEX	4.22	-
13	HL Technology	260-26038	PCB Antenna	I-PEX	2.2	2.65
14	HL Technology	260-26039	PCB Antenna	I-PEX	1.92	2.49
15	Wanshih Electronic Co., Ltd.	UC3WFI0095	PCB Antenna	I-PEX	4.45	2.76
16	Wanshih Electronic Co., Ltd.	UC3WFI0063	PCB Antenna	I-PEX	2.04	2.68
17	Wanshih Electronic Co., Ltd.	UC3WFI0064	PCB Antenna	I-PEX	3.9	2.73

Note1:

For 2.4GHz Function:

Ant.1~17 are the same antenna type in the antenna list, antenna 3 is the highest gain antenna.

It was selected to perform the test and recorded in this report.

For 5GHz Function:

Ant.2~3, 7~9 and 13~17 are the same antenna type in the antenna list, antenna 8 is the highest gain antenna.

It was selected to perform the test and recorded in this report.

Note2:

For IEEE 802.11b/g mode (1TX/3RX):

Only Chain. 1 can be use as transmit antenna.

Chain. 1, Chain. 2 and Chain. 3 could both receive simultaneously.

For IEEE 802.11a mode (1TX/3RX):

Only Chain. 1 can be use as transmit antenna.

Chain. 1, Chain. 2 and Chain. 3 could both receive simultaneously.

For IEEE 802.11n mode (3TX/3RX):

Chain. 1, Chain. 2 and Chain. 3 can be used as transmitting/receiving antenna.

Chain. 1, Chain. 2 and Chain. 3 could both transmit/receive simultaneously.

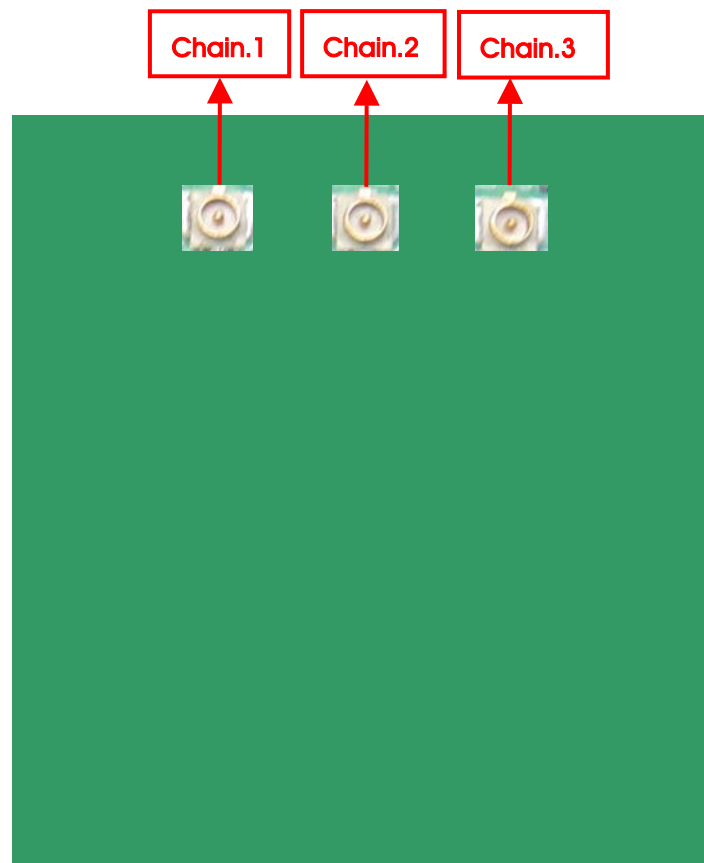

3.4. Table for Carrier Frequencies

For 2.4GHz Band:

For IEEE 802.11b/g, use Channel 1~Channel 11.

There are two bandwidth systems for IEEE 802.11n.

For both 20MHz bandwidth systems, use Channel 1~Channel 11.

For both 40MHz bandwidth systems, use Channel 3~Channel 9.

Frequency Band	Channel No.	Frequency	Channel No.	Frequency
2400~2483.5MHz	1	2412 MHz	7	2442 MHz
	2	2417 MHz	8	2447 MHz
	3	2422 MHz	9	2452 MHz
	4	2427 MHz	10	2457 MHz
	5	2432 MHz	11	2462 MHz
	6	2437 MHz	-	-

For 5GHz Band:

For IEEE 802.11a, use Channel 149, 153, 157, 161, 165.

There are two bandwidth systems for IEEE 802.11n.

For 20MHz bandwidth systems, use Channel 149, 153, 157, 161, 165.

For 40MHz bandwidth systems, use Channel 151, 159.

Frequency Band	Channel No.	Frequency	Channel No.	Frequency
5725~5850 MHz Band 4	149	5745 MHz	159	5795 MHz
	151	5755 MHz	161	5805 MHz
	153	5765 MHz	165	5825 MHz
	157	5785 MHz	-	-

3.5. Table for Test Modes

Preliminary tests were performed in different data rate to find the worst radiated emission. The data rate shown in the table below is the worst-case rate with respect to the specific test item. Investigation has been done on all the possible configurations for searching the worst cases. The following table is a list of the test modes shown in this test report.

For 2.4GHz Band

Test Items	Mode	Data Rate	Channel	Chain
AC Power Line Conducted Emissions	Normal Link	Auto	-	-
Maximum Conducted Output Power	11n 20MHz	MCS0	1/6/11	1+2+3
	11n 40MHz	MCS0	3/6/9	1+2+3
	11b/CCK	1 Mbps	1/6/11	1
	11g/BPSK	6 Mbps	1/6/11	1
Power Spectral Density	11n 20MHz	MCS0	1/6/11	1+2+3
	11n 40MHz	MCS0	3/6/9	1+2+3
	11b/CCK	1 Mbps	1/6/11	1
	11g/BPSK	6 Mbps	1/6/11	1
6dB Spectrum Bandwidth	11n 20MHz	MCS0	1/6/11	1+2+3
	11n 40MHz	MCS0	3/6/9	1+2+3
	11b/CCK	1 Mbps	1/6/11	1
	11g/BPSK	6 Mbps	1/6/11	1
Radiated Emissions Below 1GHz	Normal Link	Auto	-	-
Radiated Emissions Above 1GHz	11n 20MHz	MCS0	1/6/11	1+2+3
	11n 40MHz	MCS0	3/6/9	1+2+3
	11b/CCK	1 Mbps	1/6/11	1
	11g/BPSK	6 Mbps	1/6/11	1
Band Edge Emissions	11n 20MHz	MCS0	1/6/11	1+2+3
	11n 40MHz	MCS0	3/6/9	1+2+3
	11b/CCK	1 Mbps	1/6/11	1
	11g/BPSK	6 Mbps	1/6/11	1

For 5GHz Band

Test Items	Mode	Data Rate	Channel	Antenna
AC Power Line Conducted Emissions	Normal Link	Auto	-	-
Maximum Conducted Output Power	11n 20MHz	MCS0	149/157/165	1+2+3
	11n 40MHz	MCS0	151/159	1+2+3
	11a/BPSK	6 Mbps	149/157/165	1
Power Spectral Density	11n 20MHz	MCS0	149/157/165	1+2+3
	11n 40MHz	MCS0	151/159	1+2+3
	11a/BPSK	6 Mbps	149/157/165	1
6dB Spectrum Bandwidth	11n 20MHz	MCS0	149/157/165	1+2+3
	11n 40MHz	MCS0	151/159	1+2+3
	11a/BPSK	6 Mbps	149/157/165	1
Radiated Emissions Below 1GHz	Normal Link	Auto	-	-
Radiated Emissions Above 1GHz	11n 20MHz	MCS0	149/157/165	1+2+3
	11n 40MHz	MCS0	151/159	1+2+3
	11a/BPSK	6 Mbps	149/157/165	1
Band Edge Emissions	11n 20MHz	MCS0	149/157/165	1+2+3
	11n 40MHz	MCS0	151/159	1+2+3
	11a/BPSK	6 Mbps	149/157/165	1

The following test modes were performed for all tests:

For Conducted Emission test:

Mode 1. Normal Link for 2.4GHz

Mode 2. Normal Link for 5GHz

Due to Mode 2 generated the worst test result, it was recorded in this report.

For Radiated Emission test:

< Below 1G >

Mode 1. Normal Link for 2.4GHz

Mode 2. Normal Link for 5GHz

Due to Mode 1 generated the worst test result, it was recorded in this report.

< Above 1G >

Mode 1. CTX

3.6. Table for Testing Locations

Test Site No.	Site Category	Location	FCC Reg. No.	IC File No.
03CH01-CB	SAC	Hsin Chu	262045	IC 4086D
CO01-CB	Conduction	Hsin Chu	262045	IC 4086D
TH01-CB	OVEN Room	Hsin Chu	-	-

Open Area Test Site (OATS); Semi Anechoic Chamber (SAC).

Please refer section 6 for Test Site Address.

3.7. Table for Supporting Units

For Test Site No : 03CH01-CB / CO01-CB

Support Unit	Brand	Model	FCC ID
Notebook	DELL	E6220	QDS-BRCM1049LE
Mouse	Logitech	M-U0026	DoC
Earphone	SHYARO CHI	MIC-04	N/A
Wireless AP	BELKIN	WG7016G22-LF-AK	DoC

For Test Site No : TH01-CB

Support Unit	Brand	Model	FCC ID
Notebook	DELL	M1330	E2KWM3945ABG

3.8. Table for Parameters of Test Software Setting

During testing, Channel & Power Controlling Software provided by the customer was used to control the operating channel as well as the output power level. The RF output power selection is for the setting of RF output power expected by the customer and is going to be fixed on the firmware of the final end product.

For 2.4GHz Band

Power Parameters of IEEE 802.11n MCS0 20MHz

Test Software Version	Manual Tool Version : 1.0.0.9		
Frequency	2412 MHz	2437 MHz	2462 MHz
MCS0 20MHz	51	80	54

Power Parameters of IEEE 802.11n MCS0 40MHz

Test Software Version	Manual Tool Version : 1.0.0.9		
Frequency	2422 MHz	2437 MHz	2452 MHz
MCS0 40MHz	39	57	50

Power Parameters of IEEE 802.11b/g

Test Software Version	Manual Tool Version : 1.0.0.9		
Frequency	2412 MHz	2437 MHz	2462 MHz
IEEE 802.11b	76	77	78
IEEE 802.11g	67	90	66

For 5GHz Band

Power Parameters of IEEE 802.11n MCS0 20MHz

Test Software Version	Manual Tool Version : 1.0.0.9		
Frequency	5745 MHz	5785 MHz	5825 MHz
MCS0 20MHz	60	52	58

Power Parameters of IEEE 802.11n MCS0 40MHz

Test Software Version	Manual Tool Version : 1.0.0.9	
Frequency	5755 MHz	5795 MHz
MCS0 40MHz	57	52

Power Parameters of IEEE 802.11a

Test Software Version	Manual Tool Version : 1.0.0.9		
Frequency	5745 MHz	5785 MHz	5825 MHz
IEEE 802.11a	100	100	100

3.9. Test Configurations

3.9.1. AC Power Line Conduction Emissions Test Configuration

Test Mode : Mode 2

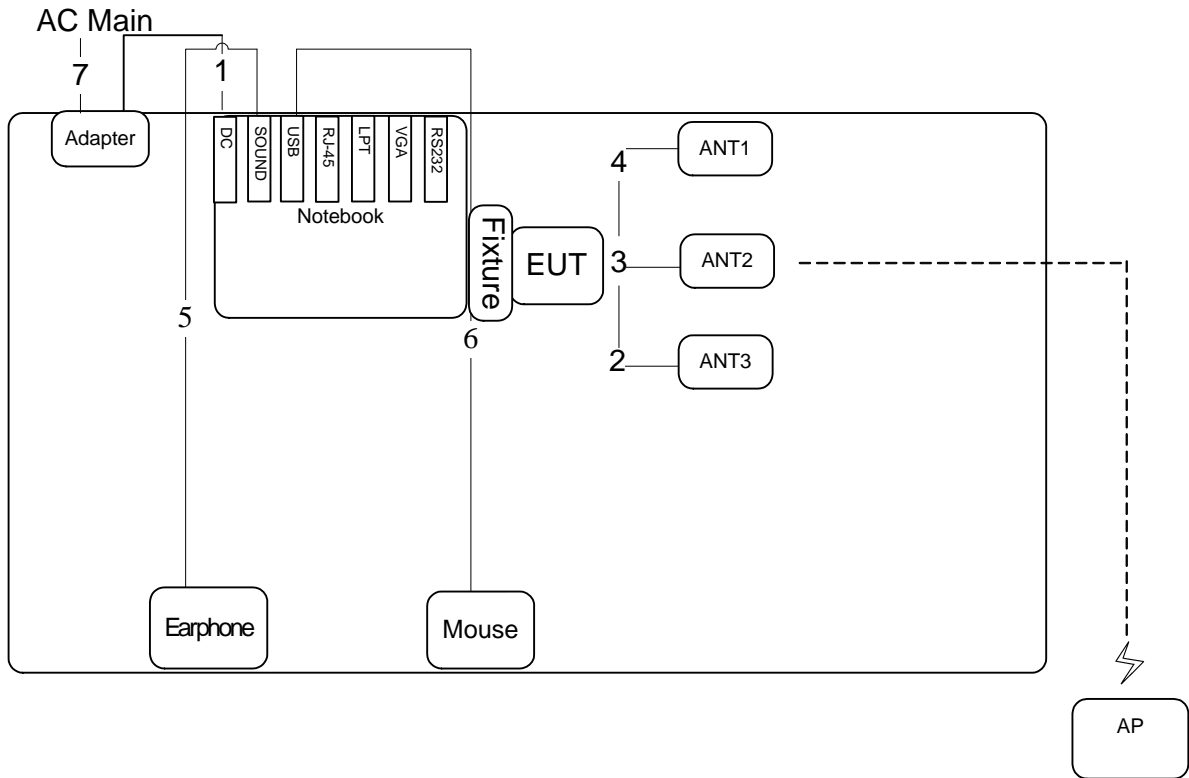

Item	Connection	Shield	Length
1	DC Power Cable	No	0.8m
2	Ant Cable	Yes	0.12m
3	Ant Cable	Yes	0.12m
4	Ant Cable	Yes	0.12m
5	Audio Cable	No	1.1m
6	USB Cable	No	1.5m
7	AC Power Cable	No	1.8m

3.9.2. Radiation Emissions Test Configuration

Test Configuration: 30MHz~1GHz

Test Mode : Mode 1

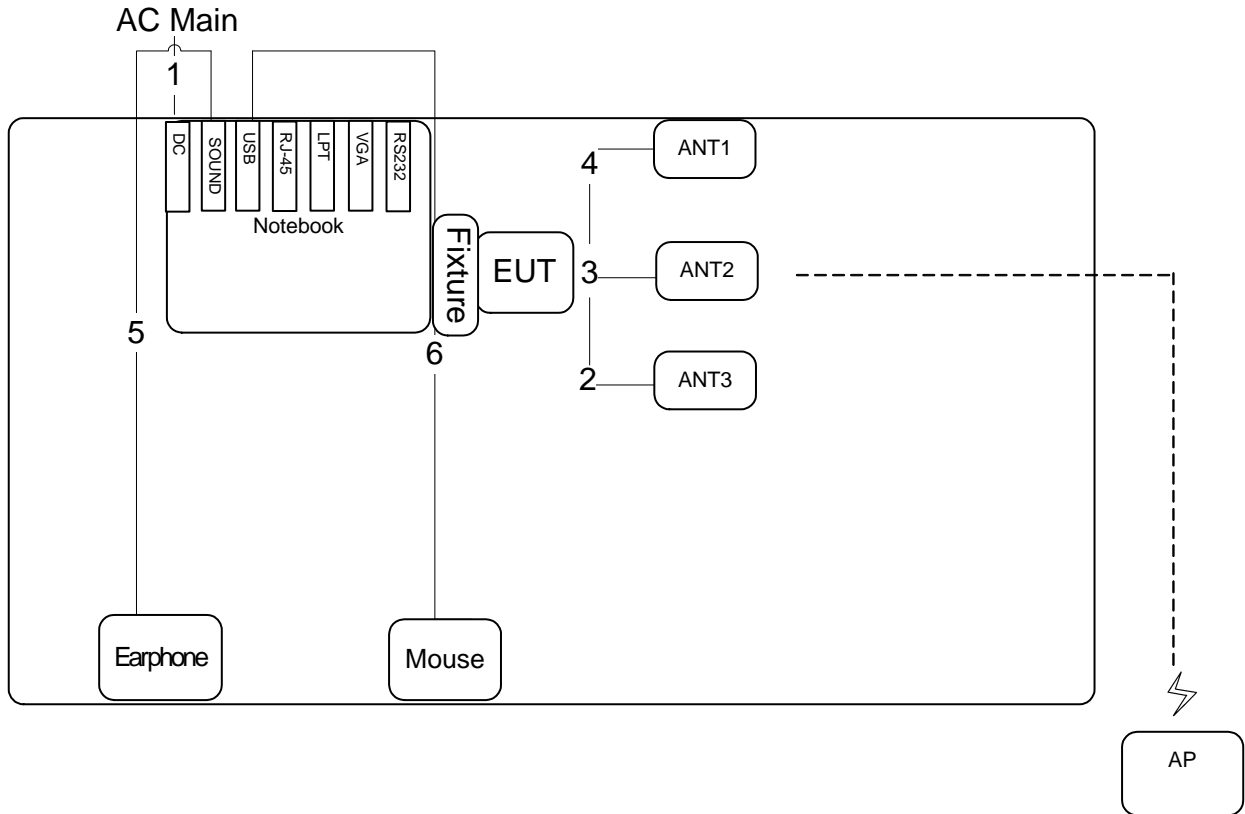

Item	Connection	Shield	Length
1	AC Power Cable	No	1.8m
2	Ant Cable	Yes	0.12m
3	Ant Cable	Yes	0.12m
4	Ant Cable	Yes	0.12m
5	Audio Cable	No	1.1m
6	USB Cable	No	1.5m

Test Configuration: above 1GHz

Test Mode : Mode 1

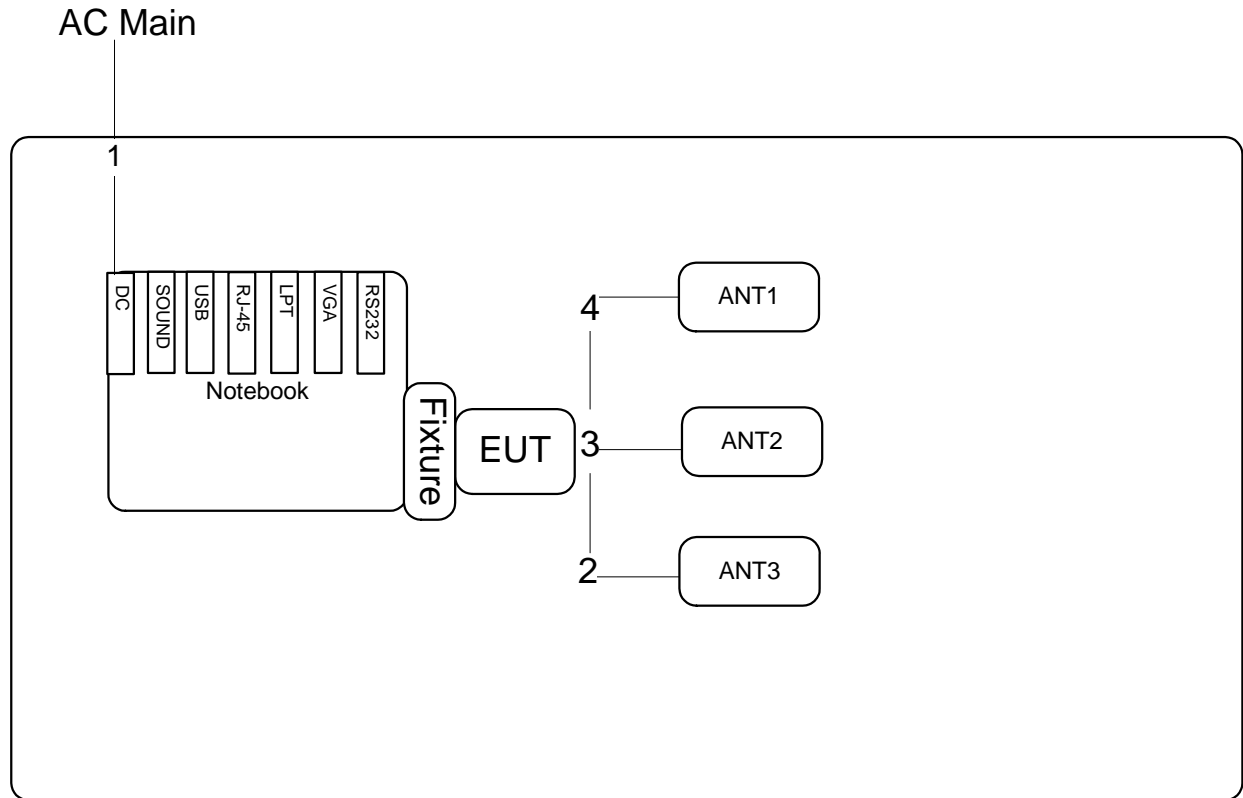

Item	Connection	Shield	Length
1	AC Power Cable	No	1.8m
2	Ant Cable	Yes	0.12m
3	Ant Cable	Yes	0.12m
4	Ant Cable	Yes	0.12m

4. TEST RESULT

4.1. AC Power Line Conducted Emissions Measurement

4.1.1. Limit

For this product which is designed to be connected to the AC power line, the radio frequency voltage that is conducted back onto the AC power line on any frequency or frequencies within the band 150 kHz to 30 MHz shall not exceed below limits table.

Frequency (MHz)	QP Limit (dBuV)	AV Limit (dBuV)
0.15~0.5	66~56	56~46
0.5~5	56	46
5~30	60	50

4.1.2. Measuring Instruments and Setting

Please refer to section 5 of equipments list in this report. The following table is the setting of the receiver.

Receiver Parameters	Setting
Attenuation	10 dB
Start Frequency	0.15 MHz
Stop Frequency	30 MHz
IF Bandwidth	9 KHz

4.1.3. Test Procedures

1. Configure the EUT according to ANSI C63.10. The EUT or host of EUT has to be placed 0.4 meter far from the conducting wall of the shielding room and at least 80 centimeters from any other grounded conducting surface.
2. Connect EUT or host of EUT to the power mains through a line impedance stabilization network (LISN).
3. All the support units are connected to the other LISNs. The LISN should provide 50uH/50ohms coupling impedance.
4. The frequency range from 150 KHz to 30 MHz was searched.
5. Set the test-receiver system to Peak Detect Function and Specified Bandwidth with Maximum Hold Mode.
6. The measurement has to be done between each power line and ground at the power terminal.

4.1.4. Test Setup Layout

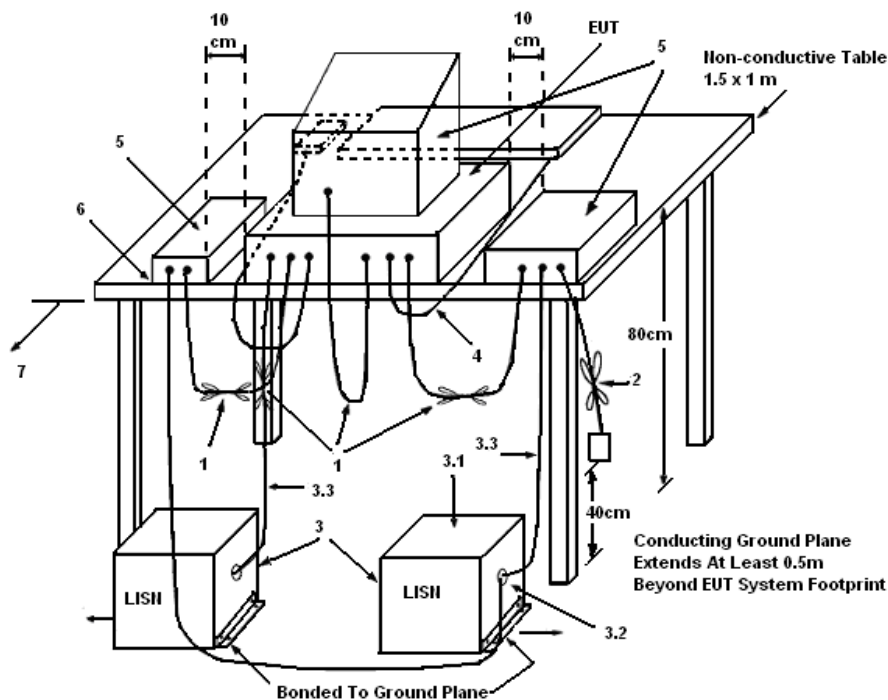

LEGEND:

- (1) Interconnecting cables that hang closer than 40 cm to the ground plane shall be folded back and forth in the center forming a bundle 30 to 40 cm long.
- (2) I/O cables that are not connected to a peripheral shall be bundled in the center. The end of the cable may be terminated, if required, using the correct terminating impedance. The overall length shall not exceed 1 m.
- (3) EUT connected to one LISN. Unused LISN measuring port connectors shall be terminated in 50 Ω . LISN can be placed on top of, or immediately beneath, reference ground plane.
- (3.1) All other equipment powered from additional LISN(s).
- (3.2) Multiple outlet strip can be used for multiple power cords of non-EUT equipment.
- (3.3) LISN at least 80 cm from nearest part of EUT chassis.
- (4) Cables of hand-operated devices, such as keyboards, mice, etc., shall be placed as for normal use.
- (5) Non-EUT components of EUT system being tested.
- (6) Rear of EUT, including peripherals, shall all be aligned and flush with rear of tabletop.
- (7) Rear of tabletop shall be 40 cm removed from a vertical conducting plane that is bonded to the ground plane.

4.1.5. Test Deviation

There is no deviation with the original standard.

4.1.6. EUT Operation during Test

The EUT was placed on the test table and programmed in normal function.

4.1.7. Results of AC Power Line Conducted Emissions Measurement

Temperature	21°C	Humidity	59%
Test Engineer	Ryo Fan	Phase	Line
Configuration	Normal Link / Mode 2		

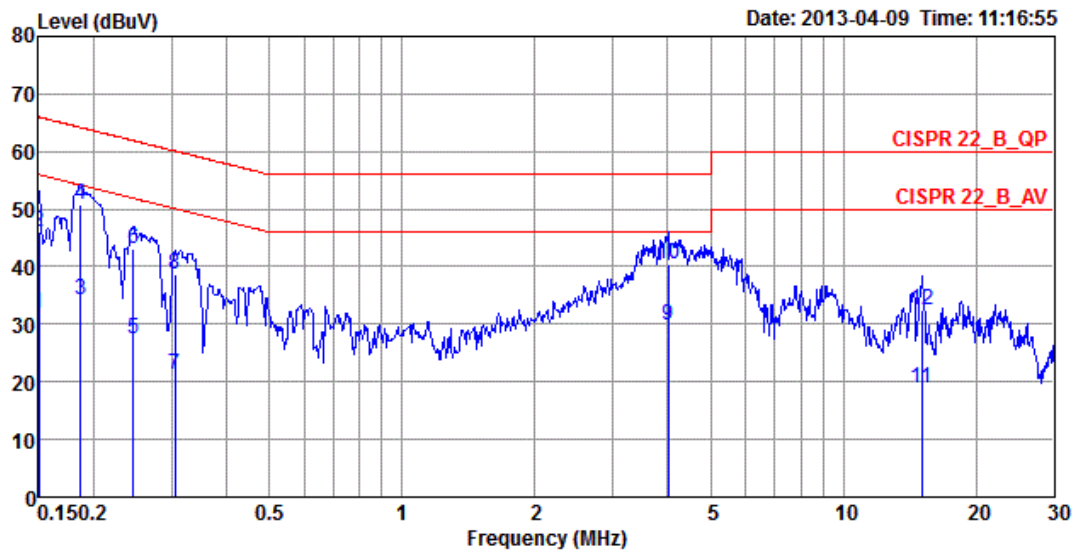

	Freq	Level	Over Limit	Limit Line	Read Level	LISN Factor	Cable Loss	Remark
	MHz	dBuV	dB	dBuV	dBuV	dB	dB	
1	0.15	31.94	-24.06	56.00	31.67	0.22	0.05	Average
2	0.15	46.10	-19.90	66.00	45.83	0.22	0.05	QP
3	0.19	34.38	-19.82	54.20	34.10	0.21	0.07	Average
4	pp	0.19	50.77	-13.43	64.20	0.21	0.07	QP
5	0.25	27.50	-24.41	51.91	27.23	0.21	0.06	Average
6	0.25	43.24	-18.67	61.91	42.97	0.21	0.06	QP
7	0.31	21.32	-28.78	50.10	21.04	0.22	0.06	Average
8	0.31	38.55	-21.55	60.10	38.27	0.22	0.06	QP
9	av	4.01	29.74	-16.26	46.00	0.29	0.13	Average
10	4.01	40.52	-15.48	56.00	40.10	0.29	0.13	QP
11	15.07	18.87	-31.13	50.00	18.15	0.61	0.11	Average
12	15.07	32.49	-27.51	60.00	31.77	0.61	0.11	QP

Temperature	21°C	Humidity	59%
Test Engineer	Ryo Fan	Phase	Neutral
Configuration	Normal Link / Mode 2		

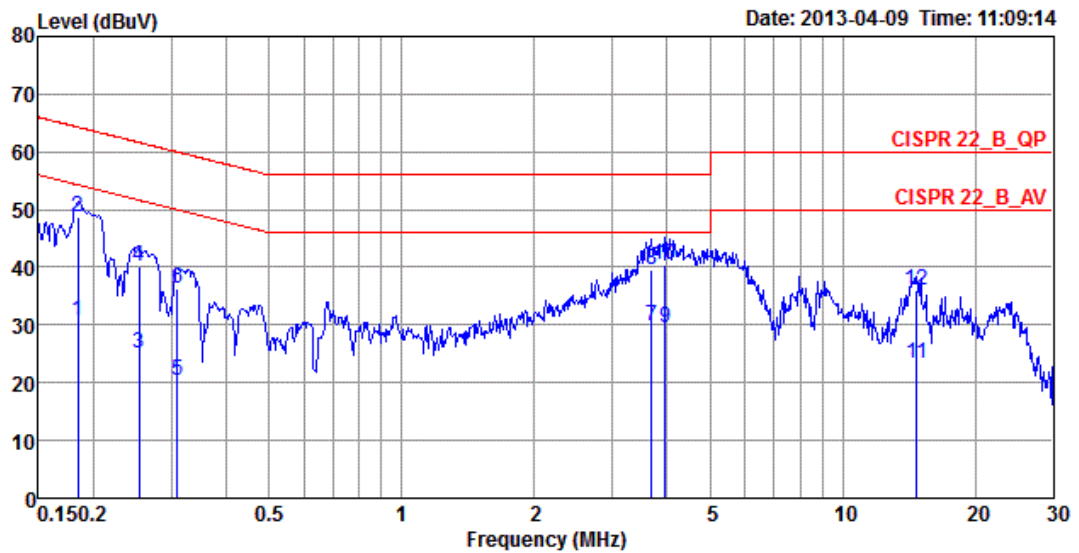

	Freq	Level	Over Limit	Limit Line	Read Level	LISN Factor	Cable Loss	Remark
	MHz	dBuV	dB	dBuV	dBuV	dB	dB	
1	0.18	30.60	-23.68	54.28	30.45	0.08	0.07	Average
2	0.18	48.69	-15.59	64.28	48.54	0.08	0.07	QP
3	0.25	25.17	-26.47	51.64	25.04	0.07	0.06	Average
4	0.25	40.29	-21.35	61.64	40.16	0.07	0.06	QP
5	0.31	20.28	-29.69	49.97	20.14	0.08	0.06	Average
6	0.31	36.32	-23.65	59.97	36.18	0.08	0.06	QP
7 av	3.68	29.75	-16.25	46.00	29.48	0.15	0.12	Average
8	3.68	39.52	-16.48	56.00	39.25	0.15	0.12	QP
9	3.96	29.62	-16.38	46.00	29.34	0.15	0.13	Average
10 pp	3.96	40.58	-15.42	56.00	40.30	0.15	0.13	QP
11	14.75	23.35	-26.65	50.00	22.84	0.40	0.11	Average
12	14.75	36.03	-23.97	60.00	35.52	0.40	0.11	QP

Note:

Level = Read Level + LISN Factor + Cable Loss

4.2. Maximum Conducted Output Power Measurement

4.2.1. Limit

For systems using digital modulation in the 2400-2483.5MHz, the limit for output power is 30dBm. The limited has to be reduced by the amount in dB that the gain of the antenna exceed 6dBi. In case of point-to-point operation, the limit has to be reduced by 1dB for every 3dB that the directional gain of the antenna exceeds 6dBi. Systems operating in the 5725-5850 MHz band that are used exclusively for fixed, point-to-point operations may employ transmitting antennas with directional gain greater than 6 dBi without any corresponding reduction in transmitter output power.

4.2.2. Measuring Instruments and Setting

Please refer to section 5 of equipments list in this report. The following table is the setting of the power meter.

Power Meter Parameter	Setting
Bandwidth	50MHz bandwidth is greater than the EUT emission bandwidth
Detector	Average

4.2.3. Test Procedures

1. Test procedures refer KDB558074 v01 r02 section 8.2.3 option 3.
2. This procedure provides an alternative for determining the RMS output power using a broadband RF average power meter with a thermocouple detector.

4.2.4. Test Setup Layout

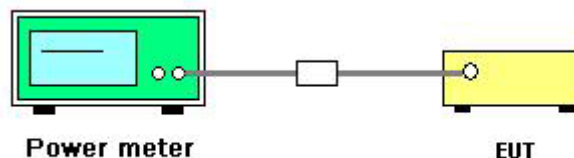

4.2.5. Test Deviation

There is no deviation with the original standard.

4.2.6. EUT Operation during Test

The EUT was programmed to be in continuously transmitting mode.

4.2.7. Test Result of Maximum Conducted Output Power

Temperature	25°C	Humidity	56%
Test Engineer	Magic Lai	Configurations	IEEE 802.11n
Test Date	Mar. 26, 2013		

For 2.4GHz Band

Configuration IEEE 802.11n MCS0 20MHz / Chain 1 + Chain 2 + Chain 3

Channel	Frequency	Conducted Power (dBm)			Total Conducted Power (dBm)	Max. Limit (dBm)	Result
		Chain 1	Chain 2	Chain 3			
1	2412 MHz	13.43	13.95	13.92	18.54	30.00	Complies
6	2437 MHz	19.57	19.98	19.87	24.58	30.00	Complies
11	2462 MHz	13.97	14.28	14.03	18.87	30.00	Complies

Configuration IEEE 802.11n MCS0 40MHz / Chain 1 + Chain 2 + Chain 3

Channel	Frequency	Conducted Power (dBm)			Total Conducted Power (dBm)	Max. Limit (dBm)	Result
		Chain 1	Chain 2	Chain 3			
3	2422 MHz	11.61	11.55	11.32	16.27	30.00	Complies
6	2437 MHz	15.37	15.57	15.23	20.16	30.00	Complies
9	2452 MHz	13.76	14.34	13.68	18.71	30.00	Complies

For 5GHz Band

Configuration IEEE 802.11n MCS0 20MHz / Chain 1 + Chain 2 + Chain 3

Channel	Frequency	Conducted Power (dBm)			Total Conducted Power (dBm)	Max. Limit (dBm)	Result
		Chain 1	Chain 2	Chain 3			
149	5745 MHz	15.52	15.44	15.80	20.36	30.00	Complies
157	5785 MHz	13.36	13.52	13.45	18.22	30.00	Complies
165	5825 MHz	15.38	14.91	15.31	19.98	30.00	Complies

Configuration IEEE 802.11n MCS0 40MHz / Chain 1 + Chain 2 + Chain 3

Channel	Frequency	Conducted Power (dBm)			Total Conducted Power (dBm)	Max. Limit (dBm)	Result
		Chain 1	Chain 2	Chain 3			
151	5755 MHz	15.38	15.06	15.36	20.04	30.00	Complies
159	5795 MHz	13.83	13.61	13.95	18.57	30.00	Complies

Temperature	25°C	Humidity	56%
Test Engineer	Magic Lai	Configurations	IEEE 802.11a/b/g
Test Date	Mar. 26, 2013		

Configuration IEEE 802.11b / Chain 1

Channel	Frequency	Conducted Power (dBm)	Max. Limit (dBm)	Result
1	2412 MHz	19.08	30.00	Complies
6	2437 MHz	19.21	30.00	Complies
11	2462 MHz	19.43	30.00	Complies

Configuration IEEE 802.11g / Chain 1

Channel	Frequency	Conducted Power (dBm)	Max. Limit (dBm)	Result
1	2412 MHz	17.23	30.00	Complies
6	2437 MHz	22.11	30.00	Complies
11	2462 MHz	16.72	30.00	Complies

Configuration IEEE 802.11a / Chain 1

Channel	Frequency	Conducted Power (dBm)	Max. Limit (dBm)	Result
149	5745 MHz	21.46	30.00	Complies
157	5785 MHz	21.32	30.00	Complies
165	5825 MHz	21.46	30.00	Complies

4.3. Power Spectral Density Measurement

4.3.1. Limit

For digitally modulated systems, the power spectral density conducted from the intentional radiator to the antenna shall not be greater than 8dBm in any 3 kHz band during any time interval of continuous transmission.

4.3.2. Measuring Instruments and Setting

Please refer to section 5 of equipments list in this report. The following table is the setting of the spectrum analyzer.

Spectrum Parameter	Setting
Attenuation	Auto
Span Frequency	Set the span to 1.5 times the DTS channel bandwidth.
RB	≥ 3 kHz
VB	$\geq 3 \times$ RBW
Detector	Peak
Trace	Max Hold
Sweep Time	Auto couple

4.3.3. Test Procedures

1. Test procedures refer KDB 558074 v01 r02 section 9.1 option 1 & KDB662911 D01 Multiple Transmitter Output v01r02 section In-Band Power Spectral Density (PSD) Measurements option (2) Measure and add $10 \log(NANT)$ dB.
2. Use this procedure when the maximum conducted output power in the fundamental emission is used to demonstrate compliance. The EUT must be configured to transmit continuously at full power over the measurement duration.
3. Ensure that the number of measurement points in the sweep $\geq 2 \times$ span/RBW (use of a greater number of measurement points than this minimum requirement is recommended).
4. Use the peak marker function to determine the maximum level in any 3 kHz band segment within the fundamental EBW.
5. The resulting PSD level must be ≤ 8 dBm.

4.3.4. Test Setup Layout

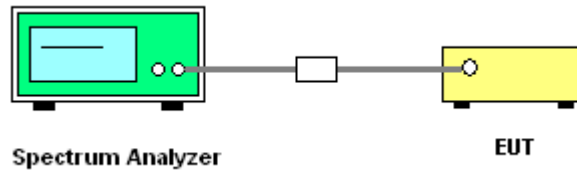

4.3.5. Test Deviation

There is no deviation with the original standard.

4.3.6. EUT Operation during Test

The EUT was programmed to be in continuously transmitting mode.

4.3.7. Test Result of Power Spectral Density

Temperature	25°C	Humidity	56%
Test Engineer	Magic Lai	Configurations	IEEE 802.11n

For 2.4GHz Band

Configuration IEEE 802.11n MCS0 20MHz / Chain 1 + Chain 2 + Chain 3

Channel	Frequency	Power Density (dBm/3kHz)			Single Port Limit (dBm/3kHz)	Result
		Chain1	Chain 2	Chain 3		
1	2412 MHz	-11.84	-11.48	-11.87	3.23	Complies
6	2437 MHz	-6.03	-6.41	-5.19	3.23	Complies
11	2462 MHz	-9.48	-9.63	-8.65	3.23	Complies

Note: PSD Limit $= (8\text{dBm} - (10\log(3))) = 3.23\text{dBm}/3\text{kHz}$

Configuration IEEE 802.11n MCS0 40MHz / Chain 1 + Chain 2 + Chain 3

Channel	Frequency	Power Density (dBm/3kHz)			Single Port Limit (dBm/3kHz)	Result
		Chain1	Chain 2	Chain 3		
3	2422 MHz	-16.81	-16.30	-16.87	3.23	Complies
6	2437 MHz	-13.21	-13.53	-12.08	3.23	Complies
9	2452 MHz	-13.95	-15.01	-14.50	3.23	Complies

Note: PSD Limit $= (8\text{dBm} - (10\log(3))) = 3.23\text{dBm}/3\text{kHz}$

For 5GHz Band

Configuration IEEE 802.11n MCS0 20MHz / Chain 1 + Chain 2 + Chain 3

Channel	Frequency	Power Density (dBm/3kHz)			Single Port Limit (dBm/3kHz)	Result
		Chain1	Chain 2	Chain 3		
149	5745 MHz	-9.60	-9.67	-9.83	3.23	Complies
157	5785 MHz	-11.68	-11.99	-11.72	3.23	Complies
165	5825 MHz	-10.81	-10.21	-10.35	3.23	Complies

Note: PSD Limit $= (8\text{dBm} - (10\log(3))) = 3.23\text{dBm}/3\text{kHz}$

Configuration IEEE 802.11n MCS0 40MHz / Chain 1 + Chain 2 + Chain 3

Channel	Frequency	Power Density (dBm/3kHz)			Single Port Limit (dBm/3kHz)	Result
		Chain1	Chain 2	Chain 3		
151	5755 MHz	-11.28	-11.46	-11.90	3.23	Complies
159	5795 MHz	-13.94	-13.92	-13.87	3.23	Complies

Note: PSD Limit $= (8\text{dBm} - (10\log(3))) = 3.23\text{dBm}/3\text{kHz}$

Temperature	25°C	Humidity	56%
Test Engineer	Magic Lai	Configurations	IEEE 802.11a/b/g

Configuration IEEE 802.11b / Chain 1

Channel	Frequency	Power Density (dBm/3kHz)	Max. Limit (dBm/3kHz)	Result
1	2412 MHz	-4.59	8.00	Complies
6	2437 MHz	-2.44	8.00	Complies
11	2462 MHz	-3.32	8.00	Complies

Configuration IEEE 802.11g / Chain 1

Channel	Frequency	Power Density (dBm/3kHz)	Max. Limit (dBm/3kHz)	Result
1	2412 MHz	-8.97	8.00	Complies
6	2437 MHz	-3.22	8.00	Complies
11	2462 MHz	-8.62	8.00	Complies

Configuration IEEE 802.11a / Chain 1

Channel	Frequency	Power Density (dBm/3kHz)	Max. Limit (dBm/3kHz)	Result
149	5745 MHz	-3.74	8.00	Complies
157	5785 MHz	-3.67	8.00	Complies
165	5825 MHz	-3.57	8.00	Complies

Note: All the test values were listed in the report.

For plots, only the channel with maximum results was shown.

Power Density Plot on Configuration IEEE 802.11n MCS0 20MHz / Chain 3 / CH 6 / 2437 MHz

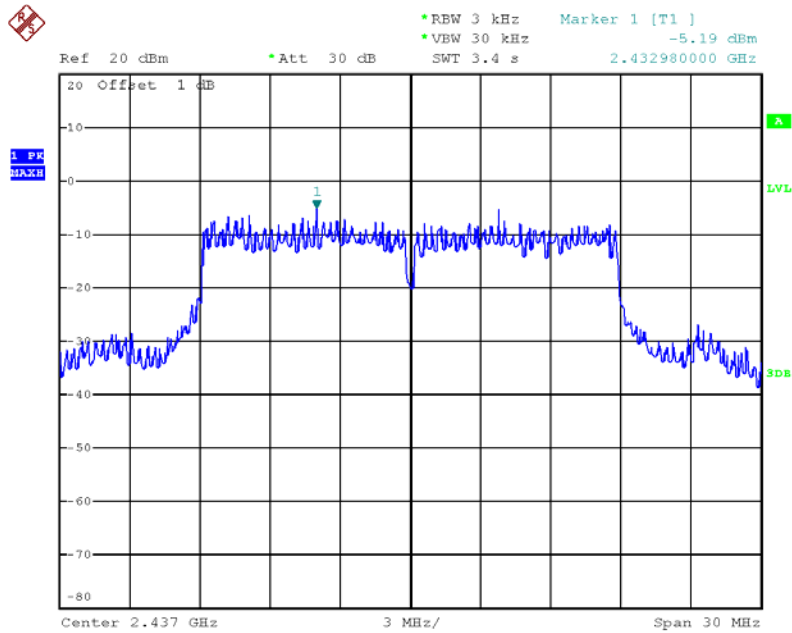

Date: 25.MAR.2013 18:01:21

Power Density Plot on Configuration IEEE 802.11n MCS0 40MHz / Chain 3 / CH 6 / 2437 MHz

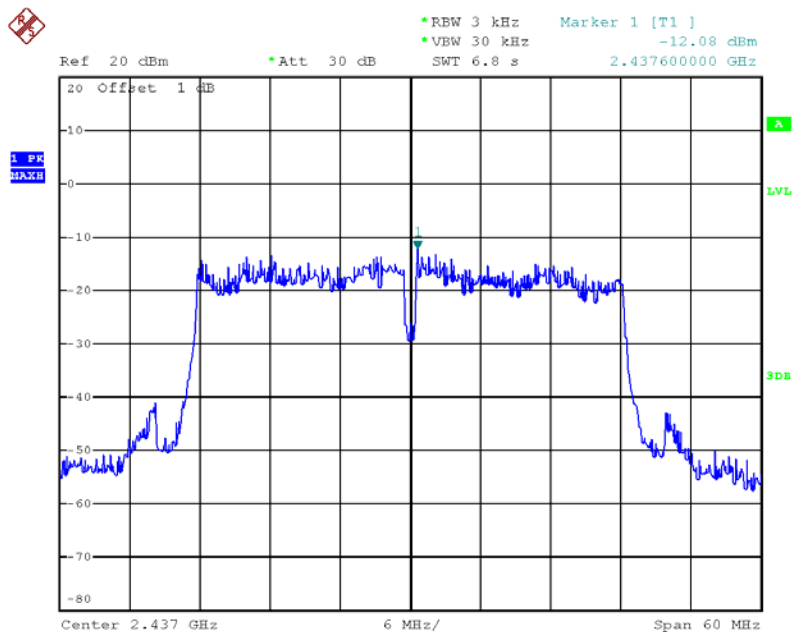

Date: 25.MAR.2013 18:11:02

Power Density Plot on Configuration IEEE 802.11n MCS0 20MHz / Chain 1 / CH 149 / 5745 MHz

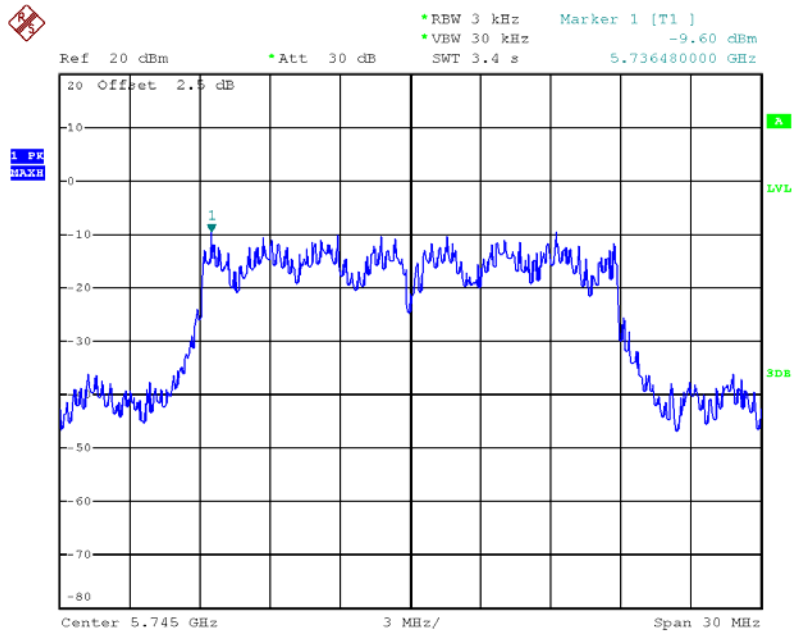

Date: 26.MAR.2013 16:07:34

Power Density Plot on Configuration IEEE 802.11n MCS0 40MHz / Chain 1 / CH 151 / 5755 MHz

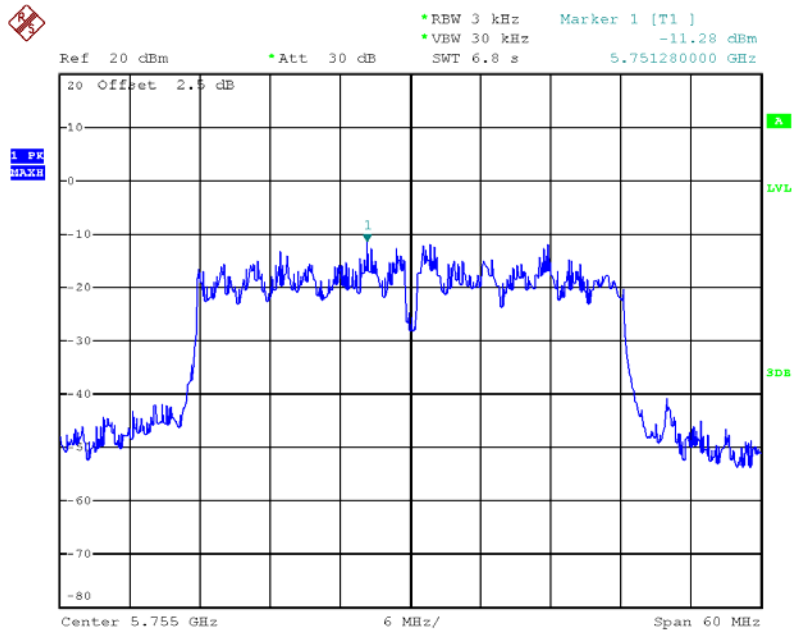

Date: 26.MAR.2013 16:12:59

Power Density Plot on Configuration IEEE 802.11b / Chain 1 / CH 6 / 2437 MHz

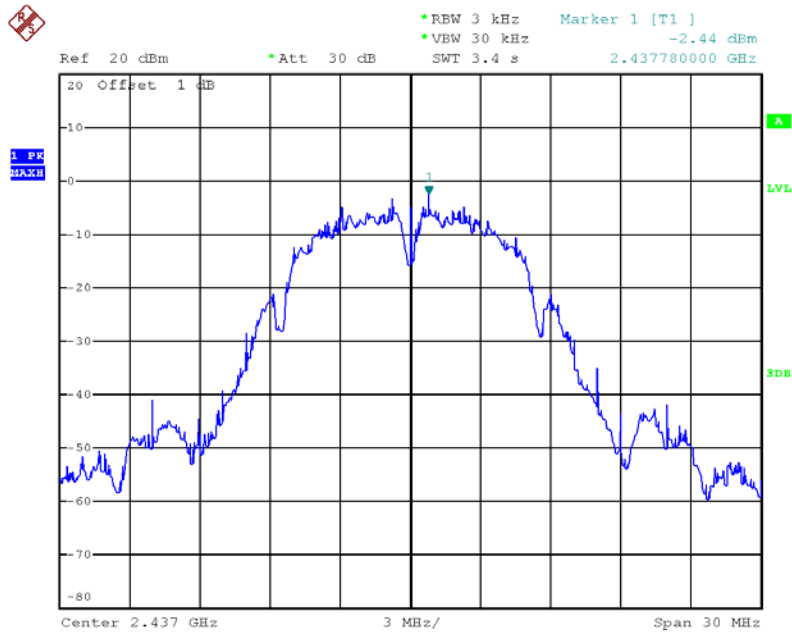

Date: 25.MAR.2013 17:49:13

Power Density Plot on Configuration IEEE 802.11g / Chain 1 / CH 6 / 2437 MHz

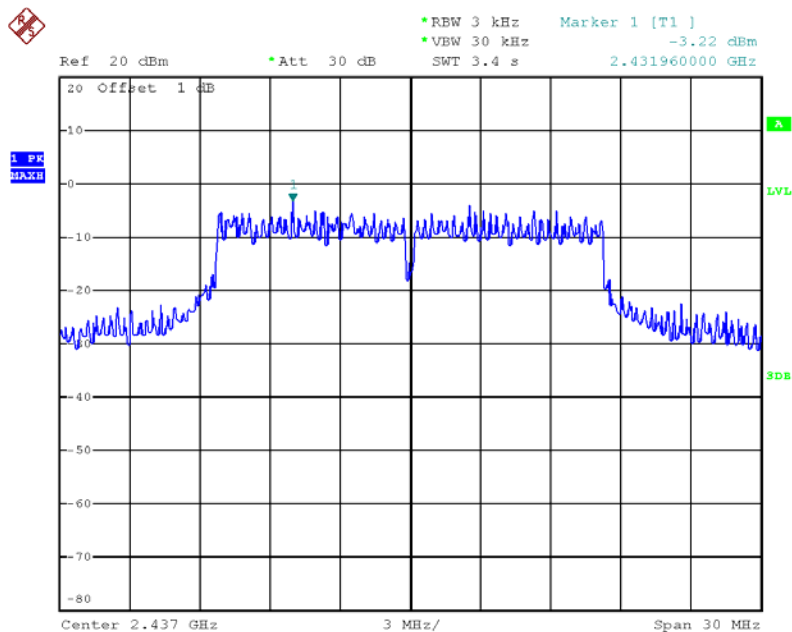

Date: 25.MAR.2013 17:53:53

Power Density Plot on Configuration IEEE 802.11a / Chain 1 / CH 165 / 5825 MHz

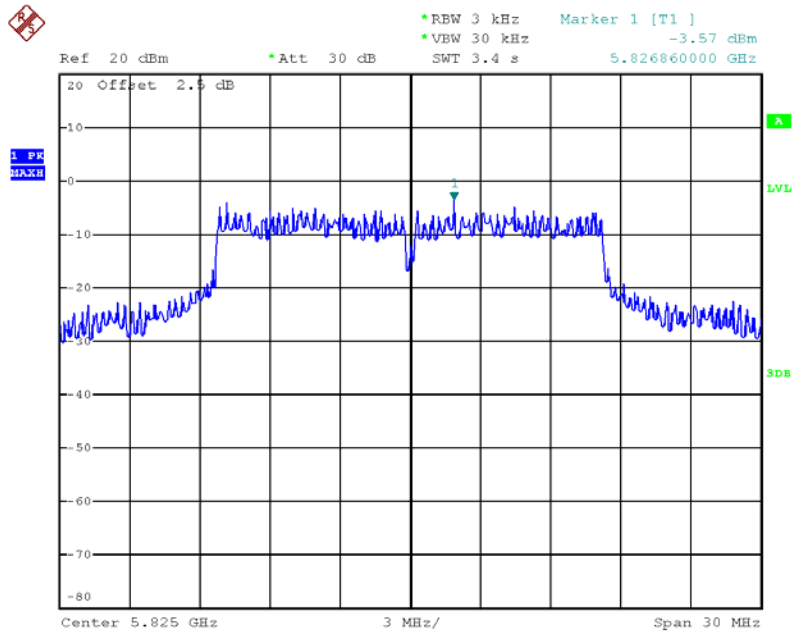

Date: 26.MAR.2013 16:06:04

4.4. 6dB Spectrum Bandwidth Measurement

4.4.1. Limit

For digital modulation systems, the minimum 6dB bandwidth shall be at least 500 kHz.

4.4.2. Measuring Instruments and Setting

Please refer to section 5 of equipments list in this report. The following table is the setting of the spectrum analyzer.

Spectrum Parameters	Setting
Attenuation	Auto
Span Frequency	> 6dB Bandwidth
RB	1-5 % or DTS BW, not exceed 100KHz
VB	$\geq 3 \times \text{RBW}$
Detector	Peak
Trace	Max Hold
Sweep Time	Auto

4.4.3. Test Procedures

1. The transmitter output (antenna port) was connected to the spectrum analyzer in peak hold mode.
2. Test was performed in accordance with KDB 558074 Guidance for Performing Compliance Measurements on Digital Transmission Systems (DTS) Operating Under §15.247 section 5.1.1 EBW Measurement Procedure
3. Multiple antenna system was performed in accordance with KDB 662911 Emissions Testing of Transmitters with Multiple Outputs in the Same Band.
4. Measured the spectrum width with power higher than 6dB below carrier.

4.4.4. Test Setup Layout

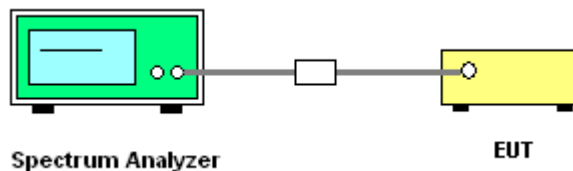

4.4.5. Test Deviation

There is no deviation with the original standard.

4.4.6. EUT Operation during Test

The EUT was programmed to be in continuously transmitting mode.

4.4.7. Test Result of 6dB Spectrum Bandwidth

Temperature	25°C	Humidity	56%
Test Engineer	Magic Lai	Configurations	IEEE 802.11n

For 2.4GHz Band

Configuration IEEE 802.11n MCS0 20MHz / Chain 1 + Chain 2 + Chain 3

Channel	Frequency	6dB Bandwidth (MHz)	99% Occupied Bandwidth (MHz)	Min. Limit (kHz)	Test Result
1	2412 MHz	15.28	17.68	500	Complies
6	2437 MHz	15.44	18.80	500	Complies
11	2462 MHz	15.20	17.68	500	Complies

Configuration IEEE 802.11n MCS0 40MHz / Chain 1 + Chain 2 + Chain 3

Channel	Frequency	6dB Bandwidth (MHz)	99% Occupied Bandwidth (MHz)	Min. Limit (kHz)	Test Result
3	2422 MHz	31.68	35.20	500	Complies
6	2437 MHz	31.52	35.36	500	Complies
9	2452 MHz	31.52	35.36	500	Complies

For 5GHz Band

Configuration IEEE 802.11n MCS0 20MHz / Chain 1 + Chain 2 + Chain 3

Channel	Frequency	6dB Bandwidth (MHz)	99% Occupied Bandwidth (MHz)	Min. Limit (kHz)	Test Result
149	5745 MHz	15.52	17.60	500	Complies
157	5785 MHz	15.68	17.60	500	Complies
165	5825 MHz	15.76	17.68	500	Complies

Configuration IEEE 802.11n MCS0 40MHz / Chain 1 + Chain 2 + Chain 3

Channel	Frequency	6dB Bandwidth (MHz)	99% Occupied Bandwidth (MHz)	Min. Limit (kHz)	Test Result
151	5755 MHz	32.96	36.32	500	Complies
159	5795 MHz	36.32	36.32	500	Complies

Temperature	25°C	Humidity	56%
Test Engineer	Magic Lai	Configurations	IEEE 802.11 a/b/g

Configuration IEEE 802.11b / Chain 1

Channel	Frequency	6dB Bandwidth (MHz)	99% Occupied Bandwidth (MHz)	Min. Limit (kHz)	Test Result
1	2412 MHz	7.84	10.24	500	Complies
6	2437 MHz	8.96	10.32	500	Complies
11	2462 MHz	8.08	10.32	500	Complies

Configuration IEEE 802.11g / Chain 1

Channel	Frequency	6dB Bandwidth (MHz)	99% Occupied Bandwidth (MHz)	Min. Limit (kHz)	Test Result
1	2412 MHz	16.48	16.72	500	Complies
6	2437 MHz	16.32	24.80	500	Complies
11	2462 MHz	16.32	16.64	500	Complies

Configuration IEEE 802.11a / Chain 1

Channel	Frequency	6dB Bandwidth (MHz)	99% Occupied Bandwidth (MHz)	Min. Limit (kHz)	Test Result
149	5745 MHz	16.40	28.24	500	Complies
157	5785 MHz	16.40	27.28	500	Complies
165	5825 MHz	16.32	28.32	500	Complies

Note: All the test values were listed in the report.

For plots, only the channel with maximum results was shown.

6 dB Bandwidth Plot on Configuration IEEE 802.11n MCS0 20MHz / Chain 1 + Chain 2 + Chain 3 / 2462 MHz

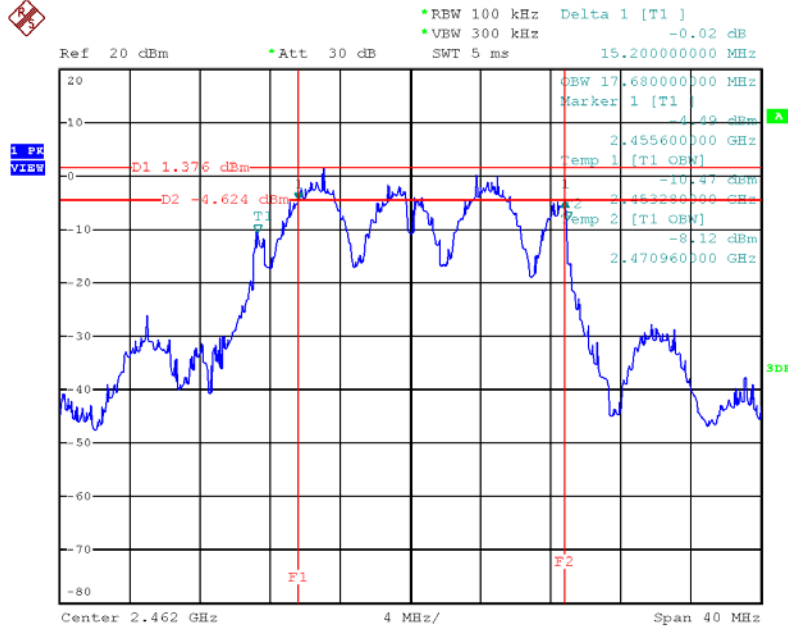

Date: 25.MAR.2013 18:26:38

6 dB Bandwidth Plot on Configuration IEEE 802.11n MCS0 40MHz / Chain 1 + Chain 2 + Chain 3 / 2437 MHz

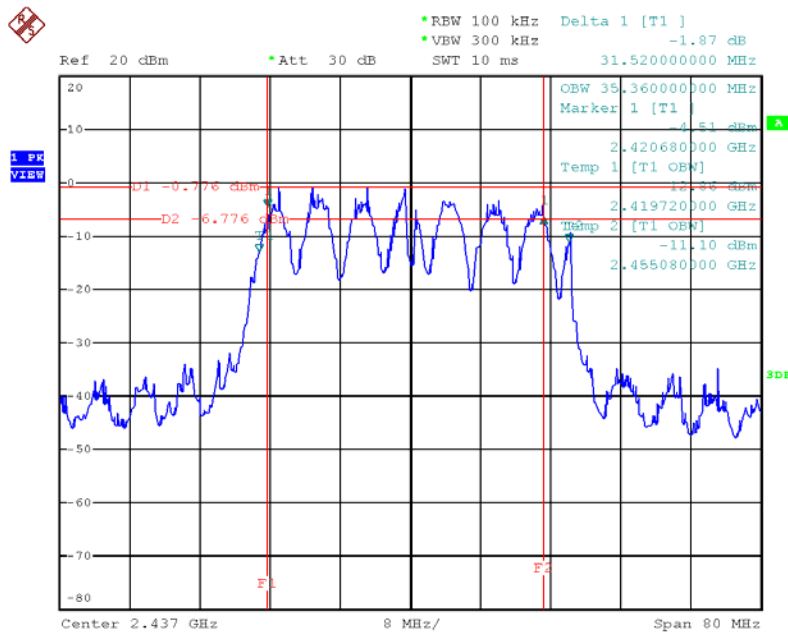

Date: 25.MAR.2013 18:28:50

6 dB Bandwidth Plot on Configuration IEEE 802.11n MCS0 20MHz / Chain 1 + Chain 2 + Chain 3 / 5745 MHz

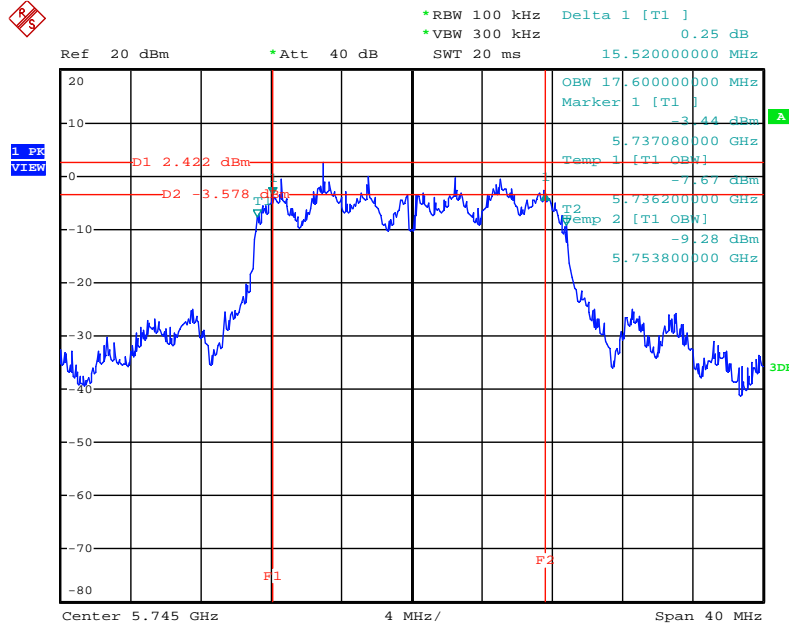

Date: 26.MAR.2013 14:42:18

6 dB Bandwidth Plot on Configuration IEEE 802.11n MCS0 40MHz / Chain 1 + Chain 2 + Chain 3 / 5755 MHz

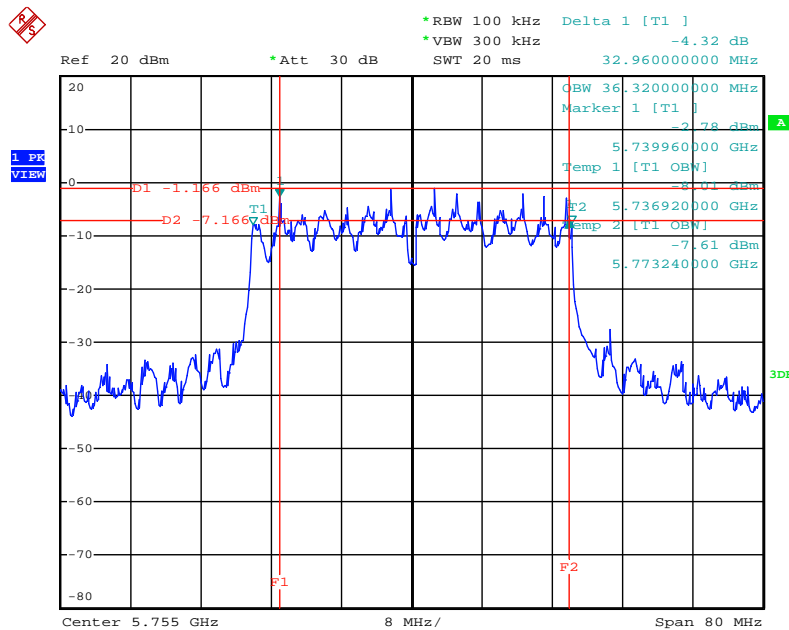

Date: 26.MAR.2013 14:43:22

6 dB Bandwidth Plot on Configuration IEEE 802.11b / Chain 1 / 2412 MHz

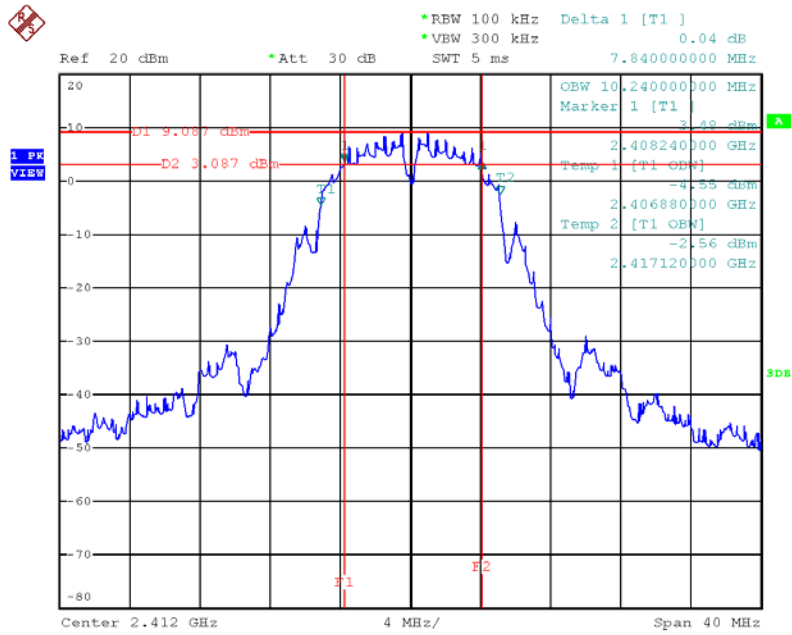

Date: 25.MAR.2013 18:33:46

6 dB Bandwidth Plot on Configuration IEEE 802.11g / Chain 1 / 2437 MHz

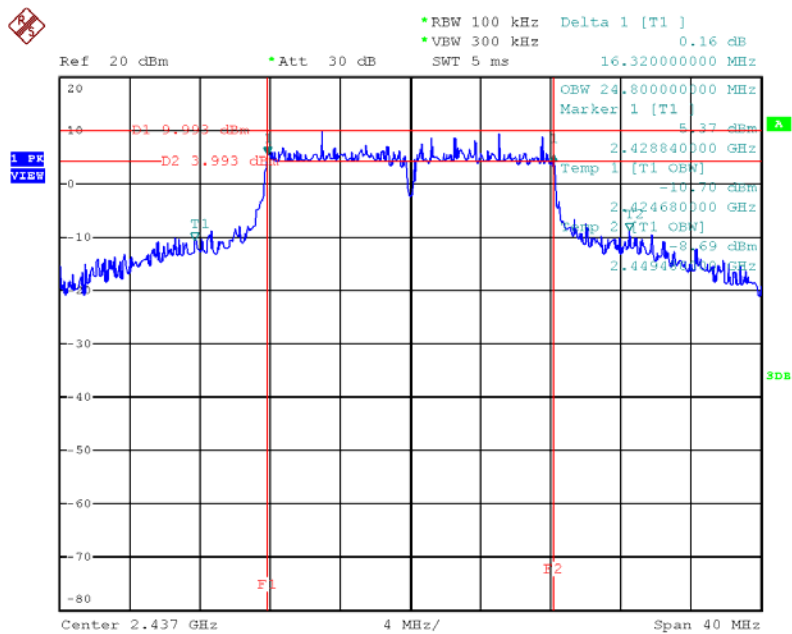

Date: 25.MAR.2013 18:37:02

6 dB Bandwidth Plot on Configuration IEEE 802.11a / Chain 1 / 5825 MHz

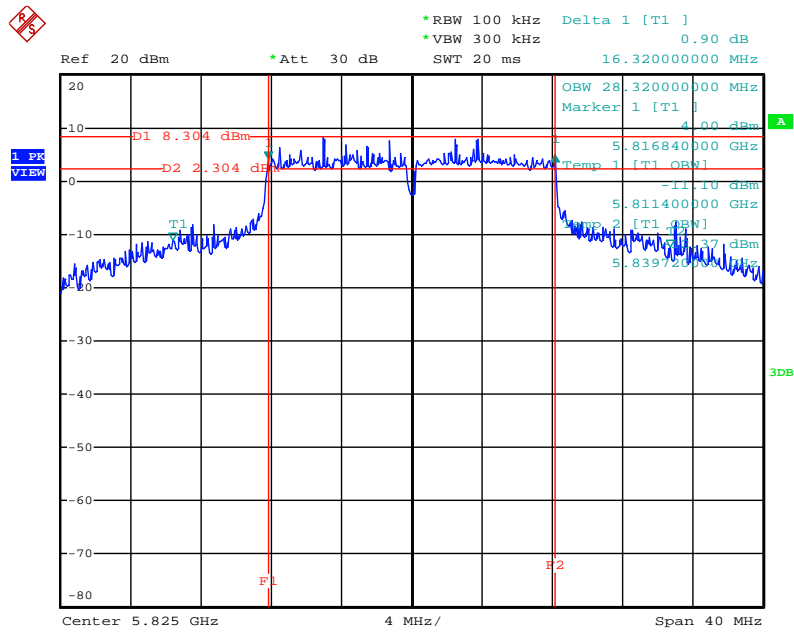

Date: 26.MAR.2013 14:37:51

4.5. Radiated Emissions Measurement

4.5.1. Limit

30dBc in any 100 kHz bandwidth outside the operating frequency band. In case the emission fall within the restricted band specified on 15.205(a), then the 15.209(a) limit in the table below has to be followed.

Frequencies (MHz)	Field Strength (microvolts/meter)	Measurement Distance (meters)
0.009~0.490	2400/F(KHz)	300
0.490~1.705	24000/F(KHz)	30
1.705~30.0	30	30
30~88	100	3
88~216	150	3
216~960	200	3
Above 960	500	3

4.5.2. Measuring Instruments and Setting

Please refer to section 5 of equipments list in this report. The following table is the setting of spectrum analyzer and receiver.

Spectrum Parameter	Setting
Attenuation	Auto
Start Frequency	1000 MHz
Stop Frequency	10th carrier harmonic
RB / VB (Emission in restricted band)	1MHz / 3MHz for Peak, 1MHz / 10Hz for Average
RB / VB (Emission in non-restricted band)	100kHz / 300kHz for peak

Receiver Parameter	Setting
Attenuation	Auto
Start ~ Stop Frequency	9kHz~150kHz / RB 200Hz for QP
Start ~ Stop Frequency	150kHz~30MHz / RB 9kHz for QP
Start ~ Stop Frequency	30MHz~1000MHz / RB 120kHz for QP

4.5.3. Test Procedures

1. Configure the EUT according to ANSI C63.10. The EUT was placed on the top of the turntable 0.8 meter above ground. The phase center of the receiving antenna mounted on the top of a height-variable antenna tower was placed 3 meters far away from the turntable.
2. Power on the EUT and all the supporting units. The turntable was rotated by 360 degrees to determine the position of the highest radiation.
3. The height of the broadband receiving antenna was varied between one meter and four meters above ground to find the maximum emissions field strength of both horizontal and vertical polarization.
4. For each suspected emissions, the antenna tower was scan (from 1 M to 4 M) and then the turntable was rotated (from 0 degree to 360 degrees) to find the maximum reading.
5. Set the test-receiver system to Peak or CISPR quasi-peak Detect Function with specified bandwidth under Maximum Hold Mode.
6. For emissions above 1GHz, use 1MHz VBW and 3MHz RBW for peak reading. Then 1MHz RBW and 10Hz VBW for average reading in spectrum analyzer.
7. When the radiated emissions limits are expressed in terms of the average value of the emissions, and pulsed operation is employed, the measurement field strength shall be determined by averaging over one complete pulse train, including blanking intervals, as long as the pulse train does not exceed 0.1 seconds. As an alternative (provided the transmitter operates for longer than 0.1 seconds) or in cases where the pulse train exceeds 0.1 seconds, the measured field strength shall be determined from the average absolute voltage during a 0.1 second interval during which the field strength is at its maximum value.
8. If the emissions level of the EUT in peak mode was 3 dB lower than the average limit specified, then testing will be stopped and peak values of EUT will be reported, otherwise, the emissions which do not have 3 dB margin will be repeated one by one using the quasi-peak method for below 1GHz.
9. For testing above 1GHz, the emissions level of the EUT in peak mode was lower than average limit (that means the emissions level in peak mode also complies with the limit in average mode), then testing will be stopped and peak values of EUT will be reported, otherwise, the emissions will be measured in average mode again and reported.
10. In case the emission is lower than 30MHz, loop antenna has to be used for measurement and the recorded data should be QP measured by receiver. High – Low scan is not required in this case.

4.5.4. Test Setup Layout

For radiated emissions below 1GHz

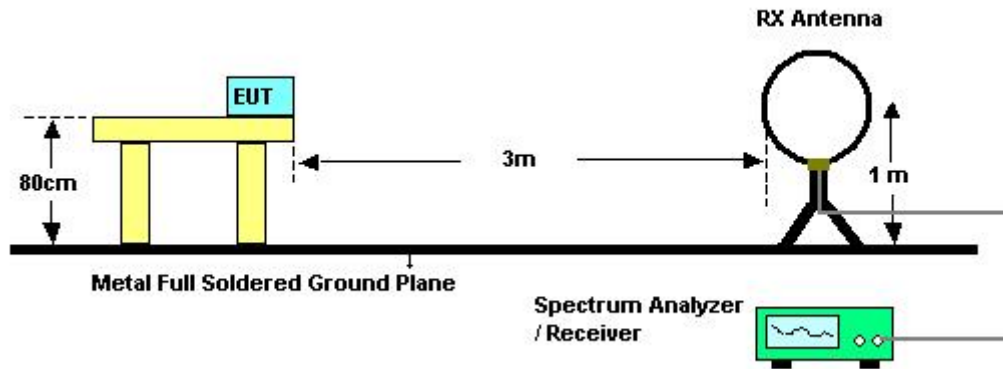

For radiated emissions above 1GHz

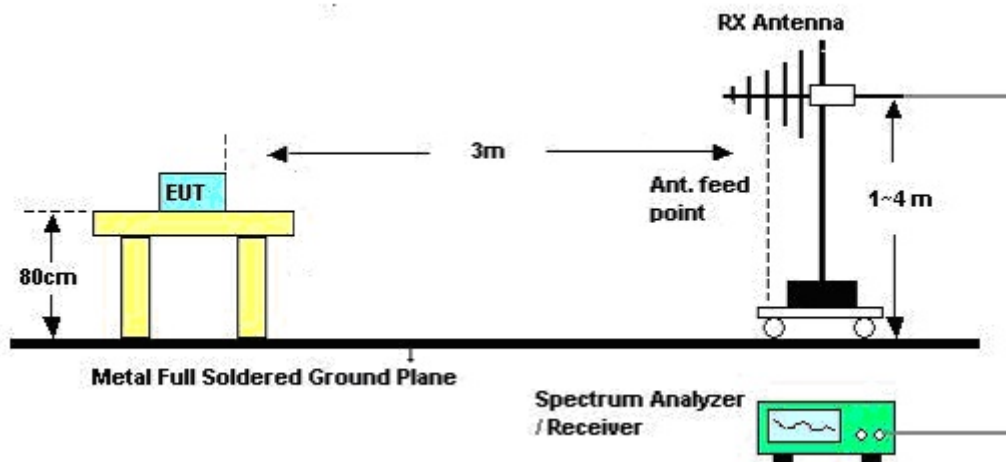

4.5.5. Test Deviation

There is no deviation with the original standard.

4.5.6. Results of Radiated Emissions (9kHz~30MHz)

Temperature	20°C	Humidity	63%
Test Engineer	Jim Huang	Configurations	Normal Link
Test Date	Mar. 07, 2013		

Freq. (MHz)	Level (dBuV)	Over Limit (dB)	Limit Line (dBuV)	Remark
-	-	-	-	See Note

Note:

The amplitude of spurious emissions that are attenuated by more than 20 dB below the permissible value has no need to be reported.

Distance extrapolation factor = $40 \log(\text{specific distance} / \text{test distance})$ (dB);

Limit line = specific limits (dBuV) + distance extrapolation factor.

4.5.7. Results of Radiated Emissions (30MHz~1GHz)

Temperature	20°C	Humidity	63%
Test Engineer	Jim Huang	Configurations	Normal Link

Horizontal

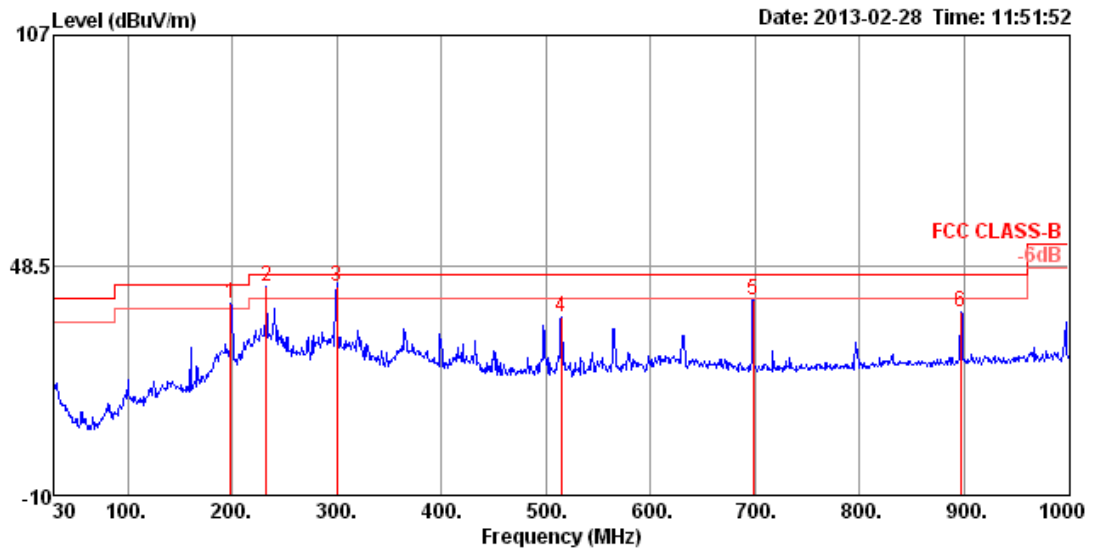

	Freq	Level	Limit Line	Over Limit	Read Level	Cable Loss	Antenna Factor	Preamp Factor	A/Pos	T/Pos	Pol/Phase	Remark
	MHz	dBuV/m	dBuV/m	dB	dBuV	dB	dB/m	dB	cm	deg		
1 !	198.78	38.64	43.50	-4.86	59.70	1.70	8.75	31.51	150	336	HORIZONTAL	Peak
2 !	232.73	42.91	46.00	-3.09	62.50	1.84	10.02	31.45	125	357	HORIZONTAL	Peak
3 pp	299.66	42.98	46.00	-3.02	59.25	2.13	13.02	31.42	125	215	HORIZONTAL	Peak
4	515.00	35.35	46.00	-10.65	46.60	2.86	17.30	31.41	200	346	HORIZONTAL	Peak
5	698.33	39.75	46.00	-6.25	48.73	3.41	18.92	31.31	150	219	HORIZONTAL	Peak
6	896.21	36.66	46.00	-9.34	43.27	3.97	20.61	31.19	125	262	HORIZONTAL	Peak

Vertical

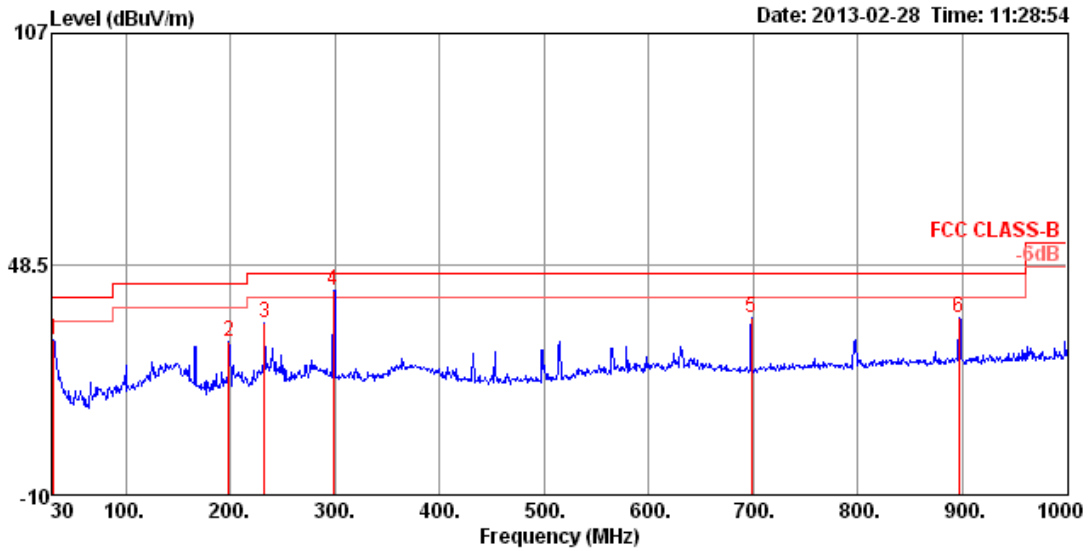

	Freq	Level	Limit	Over	Read	Cable	Antenna	Preamp	A/Pos	T/Pos	Pol/Phase	Remark
	MHz	dBuV/m	dBuV/m	dB	dBuV	dB	dB/m	dB	cm	deg		
1	30.97	29.30	40.00	-10.70	43.03	0.65	17.44	31.82	100	83	VERTICAL	Peak
2	198.78	28.94	43.50	-14.56	50.00	1.70	8.75	31.51	200	289	VERTICAL	Peak
3	232.73	33.80	46.00	-12.20	53.39	1.84	10.02	31.45	125	268	VERTICAL	Peak
4	298.69	41.96	46.00	-4.04	58.29	2.12	12.98	31.43	150	263	VERTICAL	Peak
5	698.33	34.76	46.00	-11.24	43.74	3.41	18.92	31.31	100	53	VERTICAL	Peak
6	896.21	34.89	46.00	-11.11	41.50	3.97	20.61	31.19	150	304	VERTICAL	Peak

Note:

The amplitude of spurious emissions that are attenuated by more than 20dB below the permissible value has no need to be reported.

Emission level (dBuV/m) = 20 log Emission level (uV/m).

Corrected Reading: Antenna Factor + Cable Loss + Read Level - Preamp Factor = Level.

4.5.8. Results for Radiated Emissions (1GHz~10th Harmonic)

Temperature	20°C	Humidity	63%
Test Engineer	Serway Li	Configurations	IEEE 802.11n MCS0 20MHz Ch 1 / Chain 1 + Chain 2 + Chain 3
Test Date	Mar. 07, 2013		

Horizontal

	Freq	Level	Limit Line	Over Limit	Read Level	Cable Loss	Preamp Factor	Antenna Factor	Remark	T/Pos	A/Pos	Pol/Phase
	MHz	dBuV/m	dBuV/m	dB	dBuV	dB	dB	dB/m		deg	cm	
1 a	4821.82	32.76	54.00	-21.24	30.68	4.21	34.69	32.56	Average	102	100	HORIZONTAL
2 p	4826.82	45.82	74.00	-28.18	43.74	4.21	34.69	32.56	Peak	102	100	HORIZONTAL

Vertical

	Freq	Level	Limit Line	Over Limit	Read Level	Cable Loss	Preamp Factor	Antenna Factor	Remark	T/Pos	A/Pos	Pol/Phase
	MHz	dBuV/m	dBuV/m	dB	dBuV	dB	dB	dB/m		deg	cm	
1 a	4820.41	31.69	54.00	-22.31	29.61	4.21	34.69	32.56	Average	288	100	VERTICAL
2 p	4823.84	45.05	74.00	-28.95	42.97	4.21	34.69	32.56	Peak	288	100	VERTICAL

Temperature	20°C	Humidity	63%
Test Engineer	Serway Li	Configurations	IEEE 802.11n MCS0 20MHz Ch 6 / Chain 1 + Chain 2 + Chain 3
Test Date	Mar. 07, 2013		

Horizontal

	Freq	Level	Limit	Over	Read	Cable	Preamp	Antenna	Remark	T/Pos	A/Pos	Pol/Phase
	MHz	dBuV/m	dBuV/m	dB	dBuV	dB	dB	dB/m		deg	cm	
1 a	4871.92	53.57	54.00	-0.43	51.36	4.22	34.67	32.66	Average	101	148	HORIZONTAL
2 p	4877.27	68.97	74.00	-5.03	66.76	4.22	34.67	32.66	Peak	101	148	HORIZONTAL

Vertical

	Freq	Level	Limit	Over	Read	Cable	Preamp	Antenna	Remark	T/Pos	A/Pos	Pol/Phase
	MHz	dBuV/m	dBuV/m	dB	dBuV	dB	dB	dB/m		deg	cm	
1 p	4869.83	60.86	74.00	-13.14	58.65	4.22	34.67	32.66	Peak	138	100	VERTICAL
2 a	4875.22	44.39	54.00	-9.61	42.18	4.22	34.67	32.66	Average	138	100	VERTICAL

Temperature	20°C	Humidity	63%
Test Engineer	Serway Li	Configurations	IEEE 802.11n MCS0 20MHz Ch11 / Chain 1 + Chain 2 + Chain 3
Test Date	Mar. 07, 2013		

Horizontal

	Freq	Level	Limit Line	Over Limit	Read Level	Cable Loss	Preamp Factor	Antenna Factor	Remark	T/Pos	A/Pos	Pol/Phase
	MHz	dBuV/m	dBuV/m	dB	dBuV	dB	dB	dB/m		deg	cm	
1 p	4923.39	51.51	74.00	-22.49	49.17	4.23	34.65	32.76	Peak	81	180	HORIZONTAL
2 a	4923.55	34.99	54.00	-19.01	32.65	4.23	34.65	32.76	Average	81	180	HORIZONTAL

Vertical

	Freq	Level	Limit Line	Over Limit	Read Level	Cable Loss	Preamp Factor	Antenna Factor	Remark	T/Pos	A/Pos	Pol/Phase
	MHz	dBuV/m	dBuV/m	dB	dBuV	dB	dB	dB/m		deg	cm	
1 p	4918.20	44.67	74.00	-29.33	42.37	4.22	34.65	32.73	Peak	200	100	VERTICAL
2 a	4923.55	31.97	54.00	-22.03	29.63	4.23	34.65	32.76	Average	200	100	VERTICAL

Temperature	20°C	Humidity	63%
Test Engineer	Serway Li	Configurations	IEEE 802.11n MCS0 40MHz Ch 3 / Chain 1 + Chain 2 + Chain 3
Test Date	Mar. 07, 2013		

Horizontal

	Freq	Level	Limit Line	Over Limit	Read Level	Cable Loss	Preamp Factor	Antenna Factor	Remark	T/Pos	A/Pos	Pol/Phase
	MHz	dBuV/m	dBuV/m	dB	dBuV	dB	dB	dB/m		deg	cm	
1 a	4844.66	30.45	54.00	-23.55	28.33	4.21	34.68	32.59	Average	183	100	HORIZONTAL
2 p	4844.67	43.10	74.00	-30.90	40.98	4.21	34.68	32.59	Peak	183	100	HORIZONTAL

Vertical

	Freq	Level	Limit Line	Over Limit	Read Level	Cable Loss	Preamp Factor	Antenna Factor	Remark	T/Pos	A/Pos	Pol/Phase
	MHz	dBuV/m	dBuV/m	dB	dBuV	dB	dB	dB/m		deg	cm	
1 a	4843.54	30.27	54.00	-23.73	28.15	4.21	34.68	32.59	Average	290	100	VERTICAL
2 p	4844.10	43.23	74.00	-30.77	41.11	4.21	34.68	32.59	Peak	290	100	VERTICAL

Temperature	20°C	Humidity	63%
Test Engineer	Serway Li	Configurations	IEEE 802.11n MCS0 40MHz Ch 6 / Chain 1 + Chain 2 + Chain 3
Test Date	Mar. 07, 2013		

Horizontal

	Freq	Level	Limit	Over	Read	Cable	Preamp	Antenna	Remark	T/Pos	A/Pos	Pol/Phase
	MHz	dBuV/m	dBuV/m	dB	dBuV	dB	dB	dB/m		deg	cm	
1 a	4866.89	38.27	54.00	-15.73	36.11	4.21	34.67	32.62	Average	100	179	HORIZONTAL
2 p	4867.17	54.91	74.00	-19.09	52.75	4.21	34.67	32.62	Peak	100	179	HORIZONTAL

Vertical

	Freq	Level	Limit	Over	Read	Cable	Preamp	Antenna	Remark	T/Pos	A/Pos	Pol/Phase
	MHz	dBuV/m	dBuV/m	dB	dBuV	dB	dB	dB/m		deg	cm	
1 a	4867.21	32.79	54.00	-21.21	30.63	4.21	34.67	32.62	Average	331	100	VERTICAL
2 p	4875.64	46.66	74.00	-27.34	44.45	4.22	34.67	32.66	Peak	331	100	VERTICAL

Temperature	20°C	Humidity	63%
Test Engineer	Serway Li	Configurations	IEEE 802.11n MCS0 40MHz Ch 9 / Chain 1 + Chain 2 + Chain 3
Test Date	Mar. 07, 2013		

Horizontal

	Freq	Level	Limit	Over	Read	Cable	Preamp	Antenna	Remark	T/Pos	A/Pos	Pol/Phase
	MHz	dBuV/m	dBuV/m	dB	dBuV	dB	dB	dB/m		deg	cm	
1 p	4903.96	43.39	74.00	-30.61	41.10	4.22	34.66	32.73	Peak	294	100	HORIZONTAL
2 a	4904.22	31.17	54.00	-22.83	28.88	4.22	34.66	32.73	Average	294	100	HORIZONTAL

Vertical

	Freq	Level	Limit	Over	Read	Cable	Preamp	Antenna	Remark	T/Pos	A/Pos	Pol/Phase
	MHz	dBuV/m	dBuV/m	dB	dBuV	dB	dB	dB/m		deg	cm	
1 a	4903.69	30.83	54.00	-23.17	28.54	4.22	34.66	32.73	Average	120	100	VERTICAL
2 p	4904.42	43.59	74.00	-30.41	41.30	4.22	34.66	32.73	Peak	120	100	VERTICAL

Temperature	20°C	Humidity	63%
Test Engineer	Serway Li	Configurations	IEEE 802.11n MCS0 20MHz CH 149 / Chain 1 + Chain 2 + Chain 3
Test Date	Mar. 16, 2013		

Horizontal

	Freq	Level	Limit	Over	Read	Cable	Preamp	Antenna	Remark	T/Pos	A/Pos	Pol/Phase
	MHz	dBuV/m	dBuV/m	dB	dBuV	dB	dB	dB/m		deg	cm	
1 a	5420.17	53.79	54.00	-0.21	50.32	4.52	34.62	33.57	Average	103	151	HORIZONTAL
2 p	5420.23	68.08	74.00	-5.92	64.61	4.52	34.62	33.57	Peak	103	151	HORIZONTAL

Vertical

	Freq	Level	Limit	Over	Read	Cable	Preamp	Antenna	Remark	T/Pos	A/Pos	Pol/Phase
	MHz	dBuV/m	dBuV/m	dB	dBuV	dB	dB	dB/m		deg	cm	
1 p	5368.00	64.06	74.00	-9.94	60.71	4.48	34.62	33.49	Peak	331	104	VERTICAL
2 a	5423.20	52.33	54.00	-1.67	48.86	4.52	34.62	33.57	Average	331	104	VERTICAL

Temperature	20°C	Humidity	63%
Test Engineer	Serway Li	Configurations	IEEE 802.11n MCS0 20MHz CH 157 / Chain 1 + Chain 2 + Chain 3
Test Date	Mar. 16, 2013		

Horizontal

	Freq	Level	Limit	Over	Read	Cable	Preamp	Antenna	Remark	T/Pos	A/Pos	Pol/Phase
	MHz	dBuV/m	dBuV/m	dB	dBuV	dB	dB	dB/m		deg	cm	
1 p	5392.46	68.07	74.00	-5.93	64.69	4.49	34.62	33.51	Peak	113	154	HORIZONTAL
2 a	5392.54	53.87	54.00	-0.13	50.49	4.49	34.62	33.51	Average	113	154	HORIZONTAL

Vertical

	Freq	Level	Limit	Over	Read	Cable	Preamp	Antenna	Remark	T/Pos	A/Pos	Pol/Phase
	MHz	dBuV/m	dBuV/m	dB	dBuV	dB	dB	dB/m		deg	cm	
1 a	5438.97	51.37	54.00	-2.63	47.87	4.53	34.62	33.59	Average	356	114	VERTICAL
2 p	5439.03	66.47	74.00	-7.53	62.97	4.53	34.62	33.59	Peak	356	114	VERTICAL

Temperature	20°C	Humidity	63%
Test Engineer	Serway Li	Configurations	IEEE 802.11n MCS0 20MHz CH 165 / Chain 1 + Chain 2 + Chain 3
Test Date	Mar. 16, 2013		

Horizontal

	Freq	Level	Limit	Over	Read	Cable	Preamp	Antenna	Remark	T/Pos	A/Pos	Pol/Phase
	MHz	dBuV/m	dBuV/m	dB	dBuV	dB	dB	dB/m		deg	cm	
1 p	5392.09	68.81	74.00	-5.19	65.43	4.49	34.62	33.51	Peak	106	154	HORIZONTAL
2 a	5392.41	53.68	54.00	-0.32	50.30	4.49	34.62	33.51	Average	106	154	HORIZONTAL

Vertical

	Freq	Level	Limit	Over	Read	Cable	Preamp	Antenna	Remark	T/Pos	A/Pos	Pol/Phase
	MHz	dBuV/m	dBuV/m	dB	dBuV	dB	dB	dB/m		deg	cm	
1 p	5449.07	65.70	74.00	-8.30	62.16	4.54	34.62	33.62	Peak	355	112	VERTICAL
2 a	5449.45	51.01	54.00	-2.99	47.47	4.54	34.62	33.62	Average	355	112	VERTICAL

Temperature	20°C	Humidity	63%
Test Engineer	Serway Li	Configurations	IEEE 802.11n MCS0 40MHz CH 151 / Chain 1 + Chain 2 + Chain 3
Test Date	Mar. 16, 2013		

Horizontal

	Freq	Level	Limit	Over	Read	Cable	Preamp	Antenna	Remark	T/Pos	A/Pos	Pol/Phase
	MHz	dBuV/m	dBuV/m	dB	dBuV	dB	dB	dB/m		deg	cm	
1 p	5388.84	68.23	74.00	-5.77	64.85	4.49	34.62	33.51	Peak	112	151	HORIZONTAL
2 a	5389.60	53.85	54.00	-0.15	50.47	4.49	34.62	33.51	Average	112	151	HORIZONTAL

Vertical

	Freq	Level	Limit	Over	Read	Cable	Preamp	Antenna	Remark	T/Pos	A/Pos	Pol/Phase
	MHz	dBuV/m	dBuV/m	dB	dBuV	dB	dB	dB/m		deg	cm	
1 a	5383.38	50.44	54.00	-3.56	47.06	4.49	34.62	33.51	Average	355	115	VERTICAL
2 p	5383.56	64.82	74.00	-9.18	61.44	4.49	34.62	33.51	Peak	355	115	VERTICAL

Temperature	20°C	Humidity	63%
Test Engineer	Serway Li	Configurations	IEEE 802.11n MCS0 40MHz CH 159 / Chain 1 + Chain 2 + Chain 3
Test Date	Mar. 16, 2013		

Horizontal

	Freq	Level	Limit	Over	Read	Cable	Preamp	Antenna	Remark	T/Pos	A/Pos	Pol/Phase
	MHz	dBuV/m	dBuV/m	dB	dBuV	dB	dB	dB/m		deg	cm	
1 a	5421.60	53.69	54.00	-0.31	50.22	4.52	34.62	33.57	Average	101	153	HORIZONTAL
2 p	5421.71	69.91	74.00	-4.09	66.44	4.52	34.62	33.57	Peak	101	153	HORIZONTAL

Vertical

	Freq	Level	Limit	Over	Read	Cable	Preamp	Antenna	Remark	T/Pos	A/Pos	Pol/Phase
	MHz	dBuV/m	dBuV/m	dB	dBuV	dB	dB	dB/m		deg	cm	
1 p	5421.60	66.16	74.00	-7.84	62.69	4.52	34.62	33.57	Peak	330	103	VERTICAL
2 a	5422.22	51.38	54.00	-2.62	47.91	4.52	34.62	33.57	Average	330	103	VERTICAL



Temperature	20°C	Humidity	63%
Test Engineer	Serway Li	Configurations	IEEE 802.11b CH 1 / Chain 1
Test Date	Mar. 07, 2013		

Horizontal

	Freq	Level	Limit Line	Over Limit	Read Level	Cable Loss	Antenna Factor	Preamp Factor	Remark	A/Pos	T/Pos	Pol/Phase
	MHz	dBuV/m	dBuV/m	dB	dBuV	dB	dB/m	dB		cm	deg	
1	4823.97	53.66	54.00	-0.34	52.32	3.31	33.06	35.03	Average	160	85	HORIZONTAL
2	4824.01	55.97	74.00	-18.03	54.63	3.31	33.06	35.03	Peak	160	85	HORIZONTAL

Vertical

	Freq	Level	Limit Line	Over Limit	Read Level	Cable Loss	Antenna Factor	Preamp Factor	Remark	A/Pos	T/Pos	Pol/Phase
	MHz	dBuV/m	dBuV/m	dB	dBuV	dB	dB/m	dB		cm	deg	
1	4823.97	50.02	54.00	-3.98	48.68	3.31	33.06	35.03	Average	102	341	VERTICAL
2	4823.99	52.88	74.00	-21.12	51.54	3.31	33.06	35.03	Peak	102	341	VERTICAL

Temperature	20°C	Humidity	63%
Test Engineer	Serway Li	Configurations	IEEE 802.11b CH 6 / Chain 1
Test Date	Mar. 07, 2013		

Horizontal

	Freq	Level	Limit Line	Over Limit	Read Level	Cable Loss	Antenna Factor	Preamp Factor	Remark	A/Pos	T/Pos	Pol/Phase
	MHz	dBuV/m	dBuV/m	dB	dBuV	dB	dB/m	dB		cm	deg	
1	4873.97	53.79	54.00	-0.21	52.33	3.33	33.16	35.03	Average	158	103	HORIZONTAL
2	4873.99	56.18	74.00	-17.82	54.72	3.33	33.16	35.03	Peak	158	103	HORIZONTAL
3	7310.20	37.54	54.00	-16.46	32.92	4.06	35.96	35.40	Average	137	101	HORIZONTAL
4	7311.02	48.46	74.00	-25.54	43.84	4.06	35.96	35.40	Peak	137	101	HORIZONTAL

Vertical

	Freq	Level	Limit Line	Over Limit	Read Level	Cable Loss	Antenna Factor	Preamp Factor	Remark	A/Pos	T/Pos	Pol/Phase
	MHz	dBuV/m	dBuV/m	dB	dBuV	dB	dB/m	dB		cm	deg	
1	4873.93	53.23	74.00	-20.77	51.77	3.33	33.16	35.03	Peak	102	349	VERTICAL
2	4873.97	50.13	54.00	-3.87	48.67	3.33	33.16	35.03	Average	102	349	VERTICAL
3	7311.73	46.13	74.00	-27.87	41.51	4.06	35.96	35.40	Peak	100	292	VERTICAL
4	7311.99	34.93	54.00	-19.07	30.31	4.06	35.96	35.40	Average	100	292	VERTICAL

Temperature	20°C	Humidity	63%
Test Engineer	Serway Li	Configurations	IEEE 802.11b CH 11 / Chain 1
Test Date	Mar. 07, 2013		

Horizontal

	Freq	Level	Limit Line	Over Limit	Read Level	Cable Loss	Antenna Factor	Preamp Factor	Remark	A/Pos	T/Pos	Pol/Phase
	MHz	dBuV/m	dBuV/m	dB	dBuV	dB	dB/m	dB		cm	deg	
1	4923.97	53.62	54.00	-0.38	52.02	3.35	33.26	35.01	Average	155	110	HORIZONTAL
2	4923.97	56.21	74.00	-17.79	54.61	3.35	33.26	35.01	Peak	155	110	HORIZONTAL
3	7386.71	39.91	54.00	-14.09	35.16	4.06	36.09	35.40	Average	155	206	HORIZONTAL
4	7386.94	49.52	74.00	-24.48	44.77	4.06	36.09	35.40	Peak	155	206	HORIZONTAL

Vertical

	Freq	Level	Limit Line	Over Limit	Read Level	Cable Loss	Antenna Factor	Preamp Factor	Remark	A/Pos	T/Pos	Pol/Phase
	MHz	dBuV/m	dBuV/m	dB	dBuV	dB	dB/m	dB		cm	deg	
1	4923.93	52.63	74.00	-21.37	51.03	3.35	33.26	35.01	Peak	102	356	VERTICAL
2	4923.98	49.49	54.00	-4.51	47.89	3.35	33.26	35.01	Average	102	356	VERTICAL
3	7385.02	47.44	74.00	-26.56	42.69	4.06	36.09	35.40	Peak	100	199	VERTICAL
4	7386.72	36.37	54.00	-17.63	31.62	4.06	36.09	35.40	Average	100	199	VERTICAL

Temperature	20°C	Humidity	63%
Test Engineer	Serway Li	Configurations	IEEE 802.11g CH 1 / Chain 1
Test Date	Mar. 07, 2013		

Horizontal

	Freq	Level	Limit Line	Over Limit	Read Level	Cable Loss	Preamp Factor	Antenna Factor	Remark	T/Pos	A/Pos	Pol/Phase
	MHz	dBuV/m	dBuV/m	dB	dBuV	dB	dB	dB/m		deg	cm	
1 p	4823.71	55.79	74.00	-18.21	53.71	4.21	34.69	32.56	Peak	99	148	HORIZONTAL
2 a	4823.90	39.49	54.00	-14.51	37.41	4.21	34.69	32.56	Average	99	148	HORIZONTAL

Vertical

	Freq	Level	Limit Line	Over Limit	Read Level	Cable Loss	Preamp Factor	Antenna Factor	Remark	T/Pos	A/Pos	Pol/Phase
	MHz	dBuV/m	dBuV/m	dB	dBuV	dB	dB	dB/m		deg	cm	
1 p	4823.14	48.37	74.00	-25.63	46.29	4.21	34.69	32.56	Peak	332	100	VERTICAL
2 a	4823.42	33.60	54.00	-20.40	31.52	4.21	34.69	32.56	Average	332	100	VERTICAL

Temperature	20°C	Humidity	63%
Test Engineer	Serway Li	Configurations	IEEE 802.11g CH 6 / Chain 1
Test Date	Mar. 07, 2013		

Horizontal

	Freq	Level	Limit	Over	Read	Cable	Preamp	Antenna	Remark	T/Pos	A/Pos	Pol/Phase
	MHz	dBuV/m	dBuV/m	dB	dBuV	dB	dB	dB/m		deg	cm	
1 p	4869.35	69.12	74.00	-4.88	66.91	4.22	34.67	32.66	Peak	103	162	HORIZONTAL
2 a	4874.56	53.46	54.00	-0.54	51.25	4.22	34.67	32.66	Average	103	162	HORIZONTAL

Vertical

	Freq	Level	Limit	Over	Read	Cable	Preamp	Antenna	Remark	T/Pos	A/Pos	Pol/Phase
	MHz	dBuV/m	dBuV/m	dB	dBuV	dB	dB	dB/m		deg	cm	
1 p	4871.84	61.18	74.00	-12.82	58.97	4.22	34.67	32.66	Peak	168	101	VERTICAL
2 a	4874.72	46.68	54.00	-7.32	44.47	4.22	34.67	32.66	Average	168	101	VERTICAL

Temperature	20°C	Humidity	63%
Test Engineer	Serway Li	Configurations	IEEE 802.11g CH 11 / Chain 1
Test Date	Mar. 07, 2013		

Horizontal

	Freq	Level	Limit Line	Over Limit	Read Level	Cable Loss	Preamp Factor	Antenna Factor	Remark	T/Pos	A/Pos	Pol/Phase
	MHz	dBuV/m	dBuV/m	dB	dBuV	dB	dB	dB/m		deg	cm	
1 a	4924.19	35.06	54.00	-18.94	32.72	4.23	34.65	32.76	Average	83	152	HORIZONTAL
2 p	4927.72	50.46	74.00	-23.54	48.12	4.23	34.65	32.76	Peak	83	152	HORIZONTAL

Vertical

	Freq	Level	Limit Line	Over Limit	Read Level	Cable Loss	Preamp Factor	Antenna Factor	Remark	T/Pos	A/Pos	Pol/Phase
	MHz	dBuV/m	dBuV/m	dB	dBuV	dB	dB	dB/m		deg	cm	
1 a	4923.90	32.50	54.00	-21.50	30.16	4.23	34.65	32.76	Average	200	100	VERTICAL
2 p	4924.01	45.68	74.00	-28.32	43.34	4.23	34.65	32.76	Peak	200	100	VERTICAL

Temperature	20°C	Humidity	63%
Test Engineer	Serway Li	Configurations	IEEE 802.11a CH 149 / Chain 1
Test Date	Mar. 16, 2013		

Horizontal

	Freq	Level	Limit Line	Over Limit	Read Level	Cable Loss	Preamp Factor	Antenna Factor	Remark	T/Pos	A/Pos	Pol/Phase
	MHz	dBuV/m	dBuV/m	dB	dBuV	dB	dB	dB/m		deg	cm	
1 a	11492.44	43.11	54.00	-10.89	32.69	6.74	34.82	38.50	Average	112	112	HORIZONTAL
2 p	11493.20	56.30	74.00	-17.70	45.88	6.74	34.82	38.50	Peak	112	112	HORIZONTAL

Vertical

	Freq	Level	Limit Line	Over Limit	Read Level	Cable Loss	Preamp Factor	Antenna Factor	Remark	T/Pos	A/Pos	Pol/Phase
	MHz	dBuV/m	dBuV/m	dB	dBuV	dB	dB	dB/m		deg	cm	
1 a	11490.16	43.58	54.00	-10.42	33.16	6.74	34.82	38.50	Average	10	178	VERTICAL
2 p	11491.40	57.45	74.00	-16.55	47.03	6.74	34.82	38.50	Peak	10	178	VERTICAL

Temperature	20°C	Humidity	63%
Test Engineer	Serway Li	Configurations	IEEE 802.11a CH 157 / Chain 1
Test Date	Mar. 16, 2013		

Horizontal

	Freq	Level	Limit Line	Over Limit	Read Level	Cable Loss	Preamp Factor	Antenna Factor	Remark	T/Pos	A/Pos	Pol/Phase
	MHz	dBuV/m	dBuV/m	dB	dBuV	dB	dB	dB/m		deg	cm	
1 a	11570.84	41.78	54.00	-12.22	31.36	6.77	34.85	38.50	Average	112	119	HORIZONTAL
2 p	11571.28	55.65	74.00	-18.35	45.23	6.77	34.85	38.50	Peak	112	119	HORIZONTAL

Vertical

	Freq	Level	Limit Line	Over Limit	Read Level	Cable Loss	Preamp Factor	Antenna Factor	Remark	T/Pos	A/Pos	Pol/Phase
	MHz	dBuV/m	dBuV/m	dB	dBuV	dB	dB	dB/m		deg	cm	
1 p	11569.52	54.54	74.00	-19.46	44.11	6.77	34.84	38.50	Peak	176	100	VERTICAL
2 a	11570.84	42.41	54.00	-11.59	31.99	6.77	34.85	38.50	Average	176	100	VERTICAL

Temperature	20°C	Humidity	63%
Test Engineer	Serway Li	Configurations	IEEE 802.11a CH 165 / Chain 1
Test Date	Mar. 16, 2013		

Horizontal

	Freq	Level	Limit Line	Over Limit	Read Level	Cable Loss	Preamp Factor	Antenna Factor	Remark	T/Pos	A/Pos	Pol/Phase
	MHz	dBuV/m	dBuV/m	dB	dBuV	dB	dB	dB/m		deg	cm	
1 p	11640.72	54.37	74.00	-19.63	43.93	6.80	34.86	38.50	Peak	137	132	HORIZONTAL
2 a	11650.28	41.43	54.00	-12.57	31.00	6.80	34.87	38.50	Average	137	132	HORIZONTAL

Vertical

	Freq	Level	Limit Line	Over Limit	Read Level	Cable Loss	Preamp Factor	Antenna Factor	Remark	T/Pos	A/Pos	Pol/Phase
	MHz	dBuV/m	dBuV/m	dB	dBuV	dB	dB	dB/m		deg	cm	
1 p	11645.28	56.37	74.00	-17.63	45.93	6.80	34.86	38.50	Peak	162	149	VERTICAL
2 a	11651.00	43.66	54.00	-10.34	33.23	6.80	34.87	38.50	Average	162	149	VERTICAL

Note:

The amplitude of spurious emissions that are attenuated by more than 20dB below the permissible value has no need to be reported.

Emission level (dBuV/m) = 20 log Emission level (uV/m).

Corrected Reading: Antenna Factor + Cable Loss + Read Level - Preamp Factor = Level.

4.6. Emissions Measurement

4.6.1. Limit

30dBc in any 100 kHz bandwidth outside the operating frequency band. In case the emission fall within the restricted band specified on 15.205(a), then the 15.209(a) limit in the table below has to be followed.

Frequencies (MHz)	Field Strength (micorvolts/meter)	Measurement Distance (meters)
0.009~0.490	2400/F(KHz)	300
0.490~1.705	24000/F(KHz)	30
1.705~30.0	30	30
30~88	100	3
88~216	150	3
216~960	200	3
Above 960	500	3

4.6.2. Measuring Instruments and Setting

Please refer to section 5 of equipments list in this report. The following table is the setting of the spectrum analyzer.

Spectrum Parameter	Setting
Attenuation	Auto
Span Frequency	100 MHz
RB / VB (Emission in restricted band)	1MHz / 3MHz for Peak, 1MHz / 10Hz for Average
RB / VB (Emission in non-restricted band)	100 kHz / 300 kHz for Peak

4.6.3. Test Procedures

For Radiated band edges Measurement:

- The test procedure is the same as section 4.5.3, only the frequency range investigated is limited to 100MHz around band edges.

For Conducted Out of Band Emission Measurement:

- Test was performed in accordance with KDB 558074 v02 Guidance for Performing Compliance Measurements on Digital Transmission Systems (DTS) Operating Under §15.247 section 10.1 Unwanted Emissions into Non-Restricted Frequency Bands Measurement Procedure
- The conducted emission test is performed on each TX port of operating mode without summing or adding $10\log(N)$ since the limit is relative emission limit. Only worst data of each operating mode is presented.

4.6.4. Test Setup Layout

For Radiated band edges Measurement:

This test setup layout is the same as that shown in section 4.5.4.

For Conducted Out of Band Emission Measurement:

This test setup layout is the same as that shown in section 4.4.4.

4.6.5. Test Deviation

There is no deviation with the original standard.

4.6.6. Test Result of Band Edge and Fundamental Emissions

Temperature	20°C	Humidity	63%
Test Engineer	Serway Li	Configurations	IEEE 802.11n MCS0 20MHz Ch 1, 6, 11 / Chain 1 + Chain 2 + Chain 3
Test date	Mar. 07, 2013		

Channel 1

	Freq	Level	Limit Line	Over Limit	Read Level	Cable Loss	Preamp Factor	Antenna Factor	Remark	T/Pos	A/Pos	Pol/Phase
	MHz	dBuV/m	dBuV/m	dB	dBuV	dB	dB	dB/m		deg	cm	
1 !	2389.84	71.02	74.00	-2.98	40.24	2.91	0.00	27.87	Peak	107	105	HORIZONTAL
2 !	2390.00	53.50	54.00	-0.50	22.72	2.91	0.00	27.87	Average	107	105	HORIZONTAL
3 a	2404.95	101.03			70.27	2.92	0.00	27.84	Average	107	105	HORIZONTAL
4 p	2405.11	111.01			80.25	2.92	0.00	27.84	Peak	107	105	HORIZONTAL

Item 3, 4 are the fundamental frequency at 2412 MHz.

Channel 6

	Freq	Level	Limit Line	Over Limit	Read Level	Cable Loss	Preamp Factor	Antenna Factor	Remark	T/Pos	A/Pos	Pol/Phase
	MHz	dBuV/m	dBuV/m	dB	dBuV	dB	dB	dB/m		deg	cm	
1	2388.08	65.38	74.00	-8.62	34.60	2.91	0.00	27.87	Peak	356	100	HORIZONTAL
2 !	2388.40	51.87	54.00	-2.13	21.09	2.91	0.00	27.87	Average	356	100	HORIZONTAL
3 p	2433.47	116.53			85.79	2.93	0.00	27.81	Peak	356	100	HORIZONTAL
4 a	2433.47	105.88			75.14	2.93	0.00	27.81	Average	356	100	HORIZONTAL
5 !	2483.50	51.58	54.00	-2.42	20.89	2.96	0.00	27.73	Average	356	100	HORIZONTAL
6	2483.82	66.82	74.00	-7.18	36.13	2.96	0.00	27.73	Peak	356	100	HORIZONTAL

Item 3, 4 are the fundamental frequency at 2437MHz.

Channel 11

	Freq	Level	Limit Line	Over Limit	Read Level	Cable Loss	Preamp Factor	Antenna Factor	Remark	T/Pos	A/Pos	Pol/Phase
	MHz	dBuV/m	dBuV/m	dB	dBuV	dB	dB	dB/m		deg	cm	
1 p	2453.83	112.26			81.55	2.95	0.00	27.76	Peak	54	157	HORIZONTAL
2 a	2458.47	101.57			70.86	2.95	0.00	27.76	Average	54	157	HORIZONTAL
3 !	2483.50	53.46	54.00	-0.54	22.77	2.96	0.00	27.73	Average	54	157	HORIZONTAL
4 !	2483.98	73.63	74.00	-0.37	42.94	2.96	0.00	27.73	Peak	54	157	HORIZONTAL

Item 1, 2 are the fundamental frequency at 2462 MHz.

Temperature	20°C	Humidity	63%
Test Engineer	Serway Li	Configurations	IEEE 802.11n MCS0 40MHz Ch 3, 6, 9 / Chain 1 + Chain 2 + Chain 3
Test date	Mar. 07, 2013		

Channel 3

	Freq	Level	Limit	Over	Read	Cable	Preamp	Antenna	Remark	T/Pos	A/Pos	Pol/Phase
	MHz	dBuV/m	dBuV/m	dB	dBuV	dB	dB	dB/m		deg	cm	
1	2389.68	67.79	74.00	-6.21	37.01	2.91	0.00	27.87	Peak	105	103	HORIZONTAL
2	2390.00	53.77	54.00	-0.23	22.99	2.91	0.00	27.87	Average	105	103	HORIZONTAL
3	2420.08	96.11			65.37	2.93	0.00	27.81	Average	105	103	HORIZONTAL
4	2420.40	107.66			76.92	2.93	0.00	27.81	Peak	105	103	HORIZONTAL

Item 3, 4 are the fundamental frequency at 2422 MHz.

Channel 6

	Freq	Level	Limit	Over	Read	Cable	Preamp	Antenna	Remark	T/Pos	A/Pos	Pol/Phase
	MHz	dBuV/m	dBuV/m	dB	dBuV	dB	dB	dB/m		deg	cm	
1	2388.08	68.27	74.00	-5.73	37.49	2.91	0.00	27.87	Peak	357	100	HORIZONTAL
2	2388.40	53.49	54.00	-0.51	22.71	2.91	0.00	27.87	Average	357	100	HORIZONTAL
3	2438.28	110.66			79.94	2.94	0.00	27.78	Peak	357	100	HORIZONTAL
4	2438.60	98.95			68.23	2.94	0.00	27.78	Average	357	100	HORIZONTAL
5	2483.50	68.93	74.00	-5.07	38.24	2.96	0.00	27.73	Peak	357	100	HORIZONTAL
6	2483.50	53.70	54.00	-0.30	23.01	2.96	0.00	27.73	Average	357	100	HORIZONTAL

Item 3, 4 are the fundamental frequency at 2437MHz.

Channel 9

	Freq	Level	Limit	Over	Read	Cable	Preamp	Antenna	Remark	T/Pos	A/Pos	Pol/Phase
	MHz	dBuV/m	dBuV/m	dB	dBuV	dB	dB	dB/m		deg	cm	
1	2453.60	96.39			65.68	2.95	0.00	27.76	Average	343	128	HORIZONTAL
2	2453.92	107.09			76.38	2.95	0.00	27.76	Peak	343	128	HORIZONTAL
3	2483.50	72.87	74.00	-1.13	42.18	2.96	0.00	27.73	Peak	343	128	HORIZONTAL
4	2483.82	53.72	54.00	-0.28	23.03	2.96	0.00	27.73	Average	343	128	HORIZONTAL

Item 1, 2 are the fundamental frequency at 2452 MHz.

Note:

Emission level (dBuV/m) = 20 log Emission level (uV/m).

Corrected Reading: Antenna Factor + Cable Loss + Read Level - Preamp Factor = Level.

Temperature	20°C	Humidity	63%
Test Engineer	Serway Li	Configurations	IEEE 802.11b CH 1, 6, 11 / Chain 1
Test Date	Mar. 07, 2013		

Channel 1

	Freq	Level	Limit Line	Over Limit	Read Level	Cable Loss	Antenna Factor	Preamp Factor	Remark	A/Pos	T/Pos	Pol/Phase
	MHz	dBuV/m	dBuV/m	dB	dBuV	dB	dB/m	dB		cm	deg	
1	2389.68	58.18	74.00	-15.82	27.80	2.21	28.17	0.00	Peak	100	327	VERTICAL
2	2390.00	48.15	54.00	-5.85	17.76	2.22	28.17	0.00	Average	100	327	VERTICAL
3	2411.04	108.24			77.81	2.22	28.21	0.00	Peak	100	327	VERTICAL
4	2411.20	104.45			74.02	2.22	28.21	0.00	Average	100	327	VERTICAL

Item 3, 4 are the fundamental frequency at 2412 MHz.

Channel 6

	Freq	Level	Limit Line	Over Limit	Read Level	Cable Loss	Preamp Factor	Antenna Factor	Remark	T/Pos	A/Pos	Pol/Phase
	MHz	dBuV/m	dBuV/m	dB	dBuV	dB	dB	dB/m		deg	cm	
1	2355.06	56.65	74.00	-17.35	25.84	2.89	0.00	27.92	Peak	90	100	HORIZONTAL
2	2356.81	45.23	54.00	-8.77	14.42	2.89	0.00	27.92	Average	90	100	HORIZONTAL
3 p	2436.04	109.74			79.00	2.93	0.00	27.81	Peak	90	100	HORIZONTAL
4 a	2436.04	105.91			75.17	2.93	0.00	27.81	Average	90	100	HORIZONTAL
5	2483.50	40.90	54.00	-13.10	10.21	2.96	0.00	27.73	Average	90	100	HORIZONTAL
6	2483.82	52.80	74.00	-21.20	22.11	2.96	0.00	27.73	Peak	90	100	HORIZONTAL

Item 3, 4 are the fundamental frequency at 2437 MHz.

Channel 11

	Freq	Level	Limit Line	Over Limit	Read Level	Cable Loss	Preamp Factor	Antenna Factor	Remark	T/Pos	A/Pos	Pol/Phase
	MHz	dBuV/m	dBuV/m	dB	dBuV	dB	dB	dB/m		deg	cm	
1 a	2460.24	104.78			74.07	2.95	0.00	27.76	Average	77	77	HORIZONTAL
2 p	2461.04	108.71			78.00	2.95	0.00	27.76	Peak	77	100	HORIZONTAL
3	2483.50	45.73	54.00	-8.27	15.04	2.96	0.00	27.73	Average	77	100	HORIZONTAL
4	2484.30	57.15	74.00	-16.85	26.46	2.96	0.00	27.73	Peak	77	100	HORIZONTAL

Item 1, 2 are the fundamental frequency at 2462 MHz.

Temperature	20°C	Humidity	63%
Test Engineer	Serway Li	Configurations	IEEE 802.11g CH 1, 6, 11 / Chain 1
Test Date	Mar. 07, 2013		

Channel 1

	Freq	Level	Limit Line	Over Limit	Read Level	Cable Loss	Preamp Factor	Antenna Factor	Remark	T/Pos	A/Pos	Pol/Phase
	MHz	dBuV/m	dBuV/m	dB	dBuV	dB	dB	dB/m		deg	cm	
1 !	2389.36	73.06	74.00	-0.94	42.28	2.91	0.00	27.87	Peak	89	103	HORIZONTAL
2 !	2390.00	53.74	54.00	-0.26	22.96	2.91	0.00	27.87	Average	89	103	HORIZONTAL
3 a	2404.47	98.71			67.95	2.92	0.00	27.84	Average	89	103	HORIZONTAL
4 p	2415.69	108.84			78.08	2.92	0.00	27.84	Peak	89	103	HORIZONTAL

Item 3, 4 are the fundamental frequency at 2412 MHz.

Channel 6

	Freq	Level	Limit Line	Over Limit	Read Level	Cable Loss	Preamp Factor	Antenna Factor	Remark	T/Pos	A/Pos	Pol/Phase
	MHz	dBuV/m	dBuV/m	dB	dBuV	dB	dB	dB/m		deg	cm	
1	2388.72	65.36	74.00	-8.64	34.58	2.91	0.00	27.87	Peak	88	107	HORIZONTAL
2 !	2390.00	52.75	54.00	-1.25	21.97	2.91	0.00	27.87	Average	88	107	HORIZONTAL
3 a	2440.53	104.90			74.18	2.94	0.00	27.78	Average	88	107	HORIZONTAL
4 p	2441.49	115.35			84.63	2.94	0.00	27.78	Peak	88	107	HORIZONTAL
5 !	2483.50	50.10	54.00	-3.90	19.41	2.96	0.00	27.73	Average	88	107	HORIZONTAL
6	2484.46	65.00	74.00	-9.00	34.31	2.96	0.00	27.73	Peak	88	107	HORIZONTAL

Item 3, 4 are the fundamental frequency at 2437 MHz.

Channel 11

	Freq	Level	Limit Line	Over Limit	Read Level	Cable Loss	Preamp Factor	Antenna Factor	Remark	T/Pos	A/Pos	Pol/Phase
	MHz	dBuV/m	dBuV/m	dB	dBuV	dB	dB	dB/m		deg	cm	
1 a	2454.47	97.19			66.48	2.95	0.00	27.76	Average	90	104	HORIZONTAL
2 p	2456.23	107.61			76.90	2.95	0.00	27.76	Peak	90	104	HORIZONTAL
3 !	2483.50	53.62	54.00	-0.38	22.93	2.96	0.00	27.73	Average	90	104	HORIZONTAL
4 !	2484.14	71.91	74.00	-2.09	41.22	2.96	0.00	27.73	Peak	90	104	HORIZONTAL

Item 1, 2 are the fundamental frequency at 2462 MHz.

For Emission not in Restricted Band

Plot on Configuration IEEE 802.11n MCS0 20MHz / Reference Level

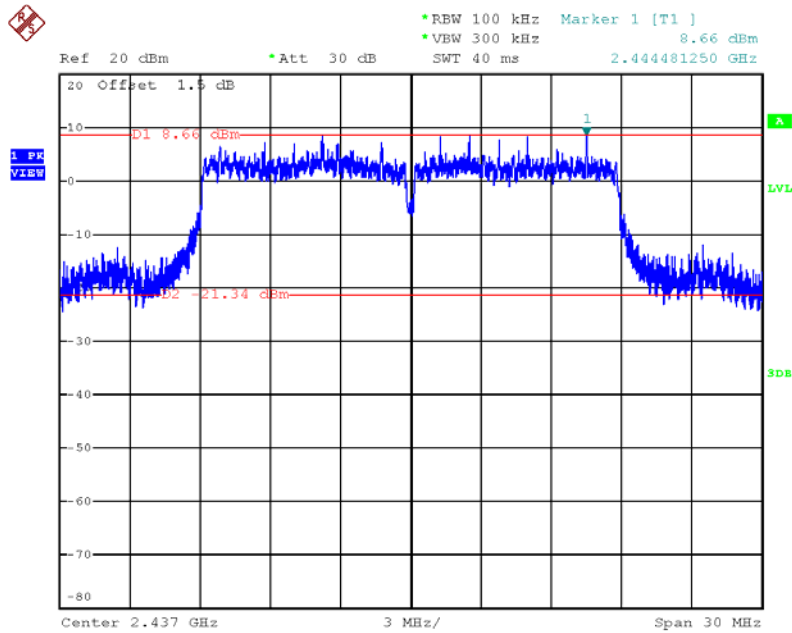

Date: 26.MAR.2013 14:10:42

Plot on Configuration IEEE 802.11n MCS0 20MHz / CH 1 / 30MHz~2400MHz (down 30dBc)

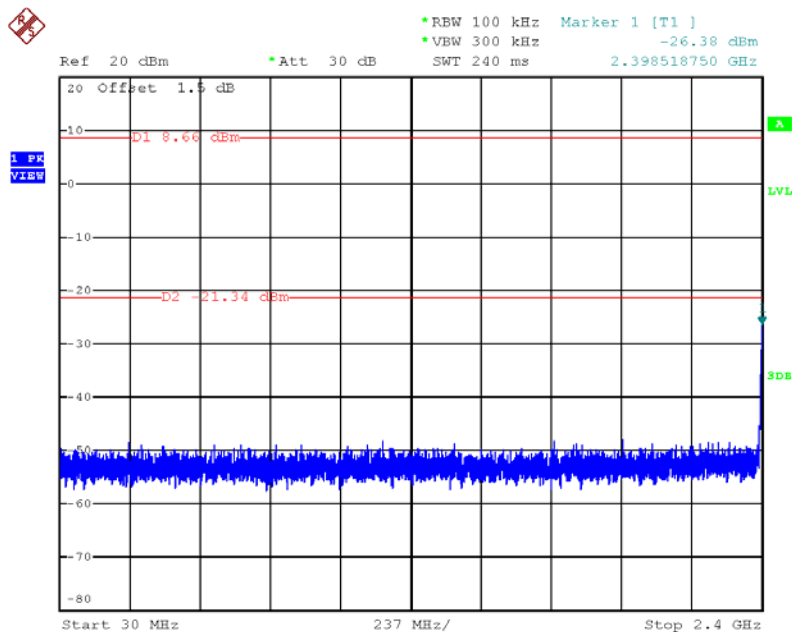

Date: 26.MAR.2013 14:11:28

Plot on Configuration IEEE 802.11n MCS0 20MHz / CH 1 / 2500MHz~26500MHz (down 30dBc)

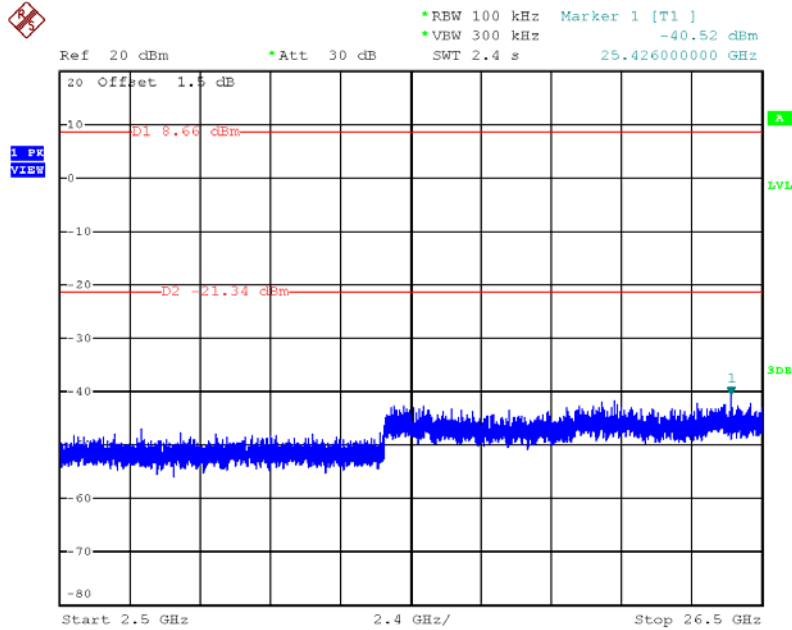

Date: 26.MAR.2013 14:11:52

Plot on Configuration IEEE 802.11n MCS0 20MHz / CH 11 / 30MHz~2400MHz (down 30dBc)

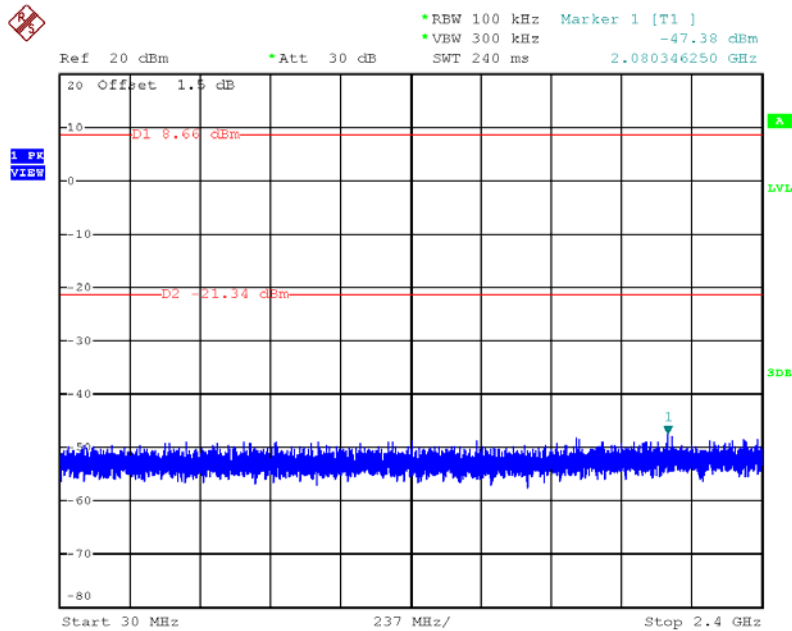

Date: 26.MAR.2013 14:13:17

Plot on Configuration IEEE 802.11n MCS0 20MHz / CH 11 / 2500MHz~26500MHz (down 30dBc)

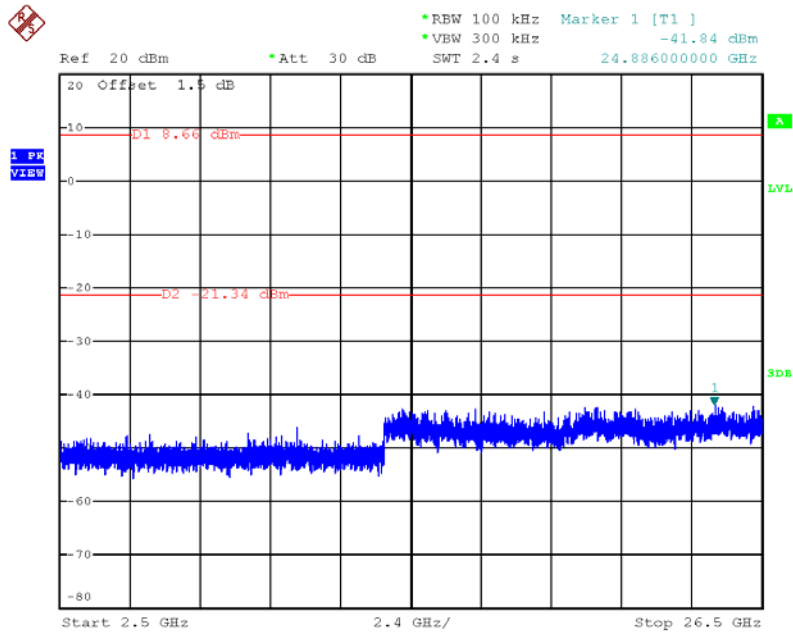

Date: 26.MAR.2013 14:12:55

Plot on Configuration IEEE 802.11n MCS0 40MHz / Reference Level

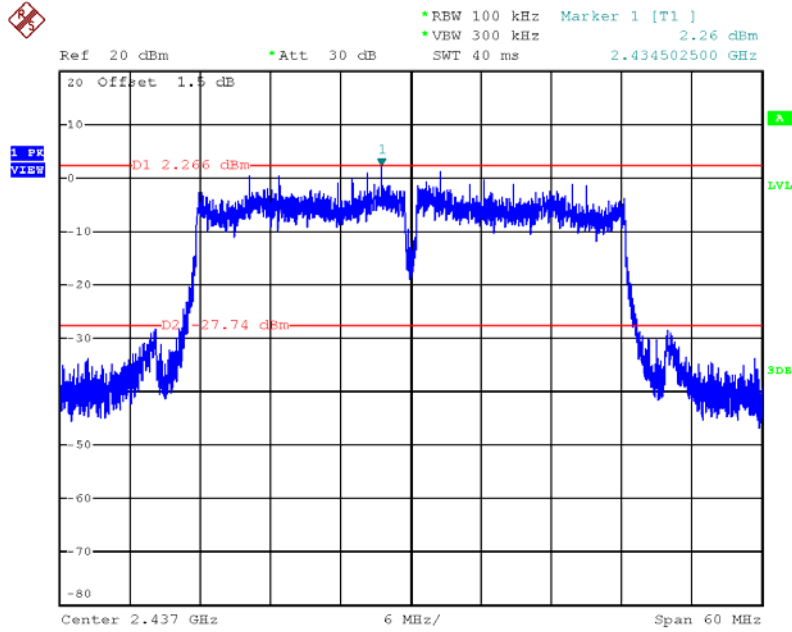

Date: 26.MAR.2013 14:15:01

Plot on Configuration IEEE 802.11n MCS0 40MHz / CH 3 / 30MHz~2400MHz (down 30dBc)

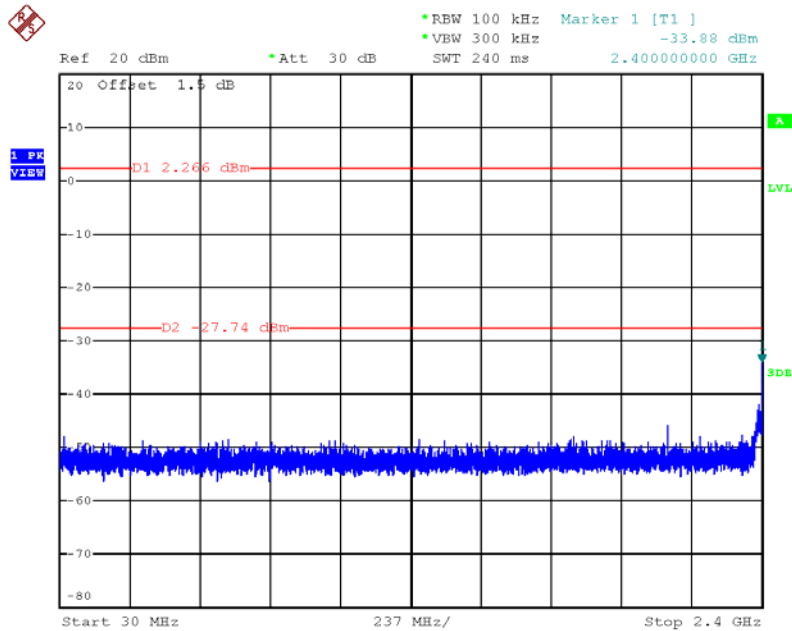

Date: 26.MAR.2013 14:15:59

Plot on Configuration IEEE 802.11n MCS0 40MHz / CH 3 / 2500MHz~26500MHz (down 30dBc)

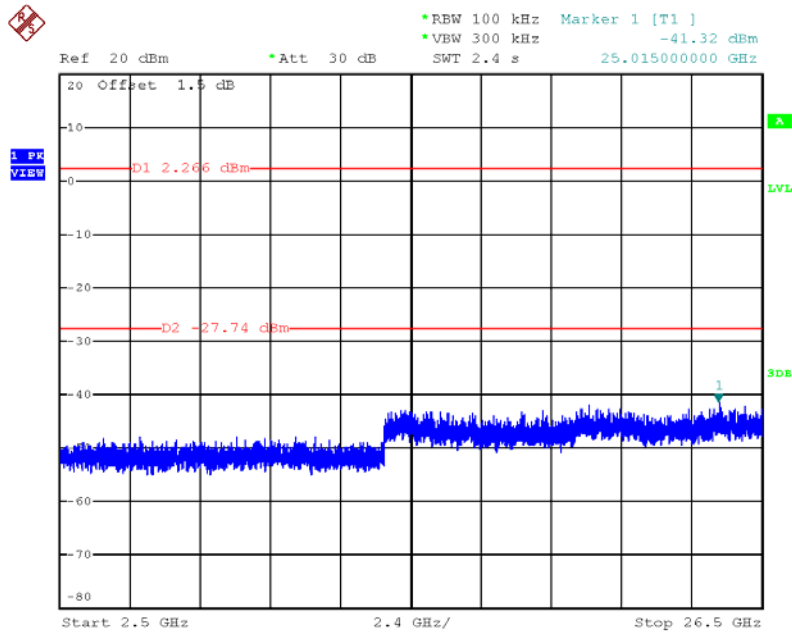

Date: 26.MAR.2013 14:16:37

Plot on Configuration IEEE 802.11n MCS0 40MHz / CH 9 / 30MHz~2400MHz (down 30dBc)

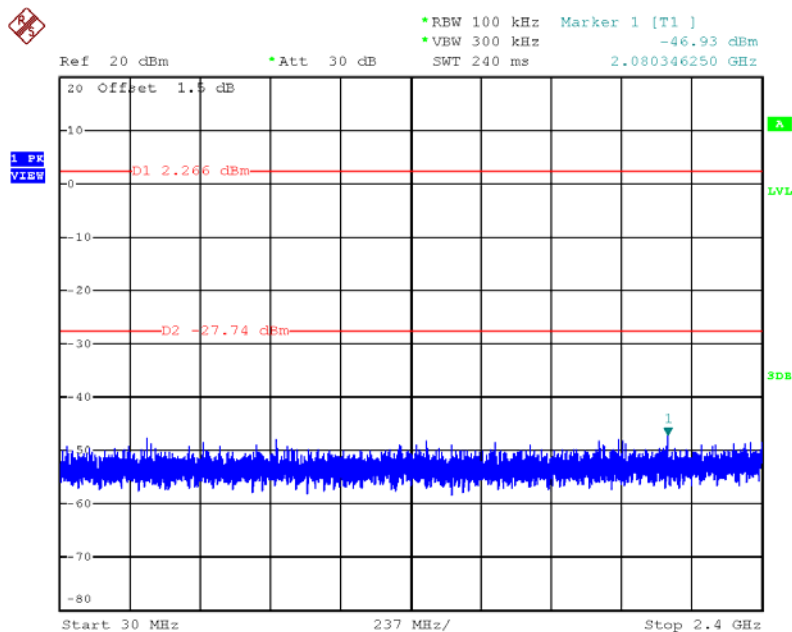

Date: 26.MAR.2013 14:17:23

Plot on Configuration IEEE 802.11n MCS0 40MHz / CH 9 / 2500MHz~26500MHz (down 30dBc)

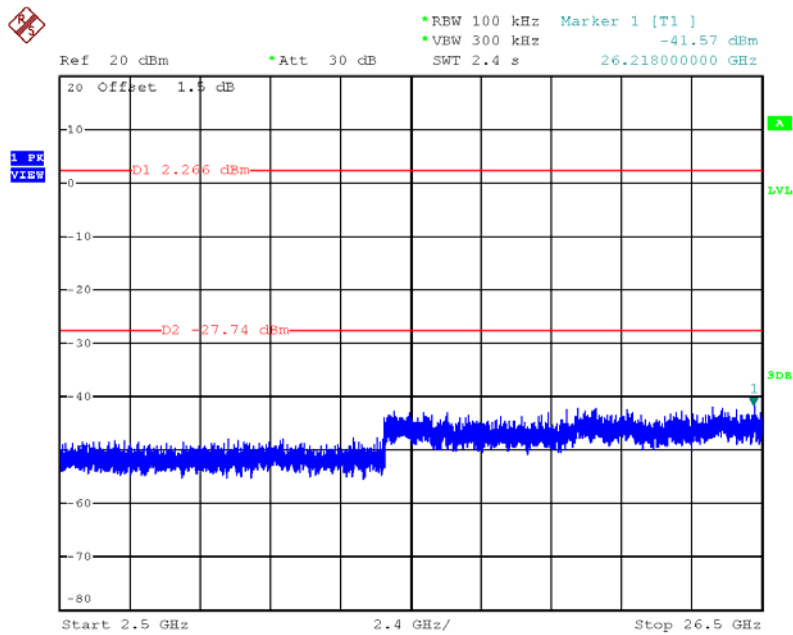

Date: 26.MAR.2013 14:17:08

Plot on Configuration IEEE 802.11n MCS0 20MHz / Reference Level

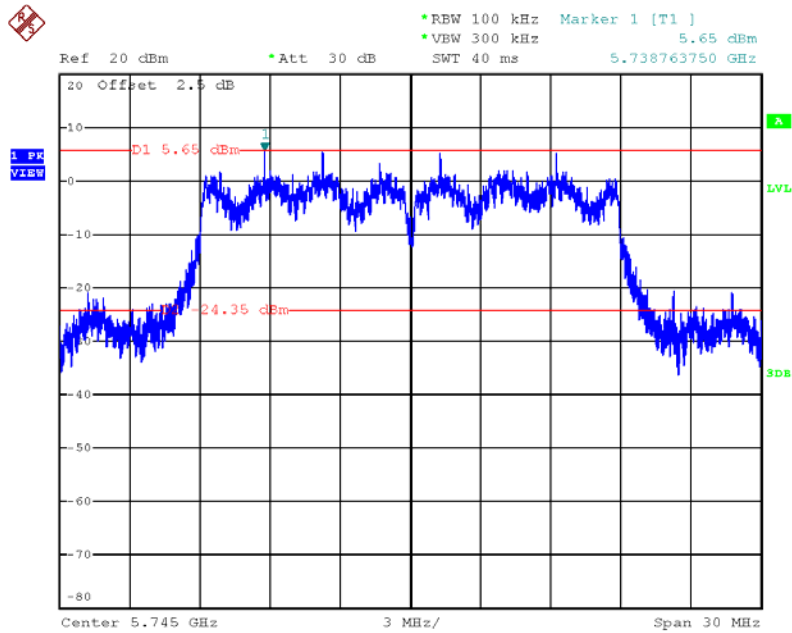

Date: 26.MAR.2013 16:25:57

Plot on Configuration IEEE 802.11n MCS0 20MHz / CH 149 / 30MHz~5725MHz (down 30dBc)

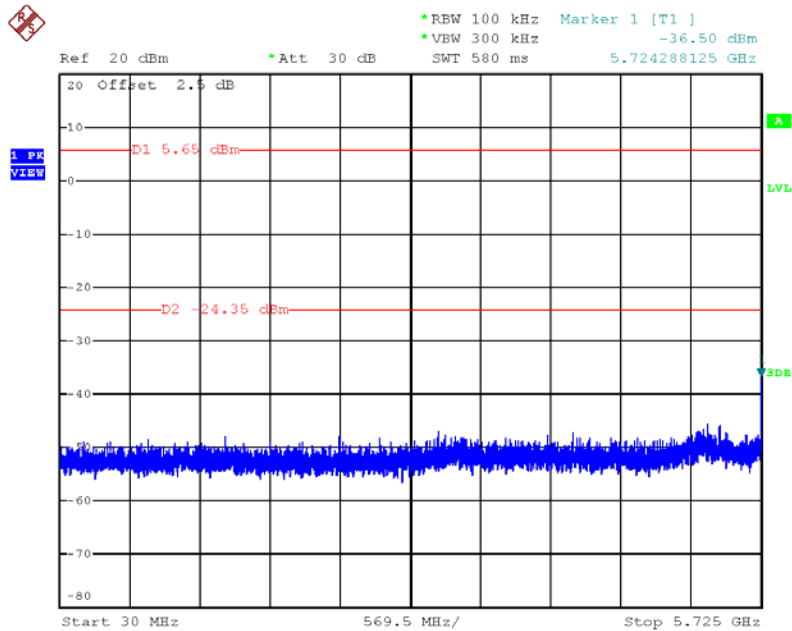

Date: 26.MAR.2013 16:26:27

Plot on Configuration IEEE 802.11n MCS0 20MHz / CH 149 / 5850MHz~40000MHz (down 30dBc)

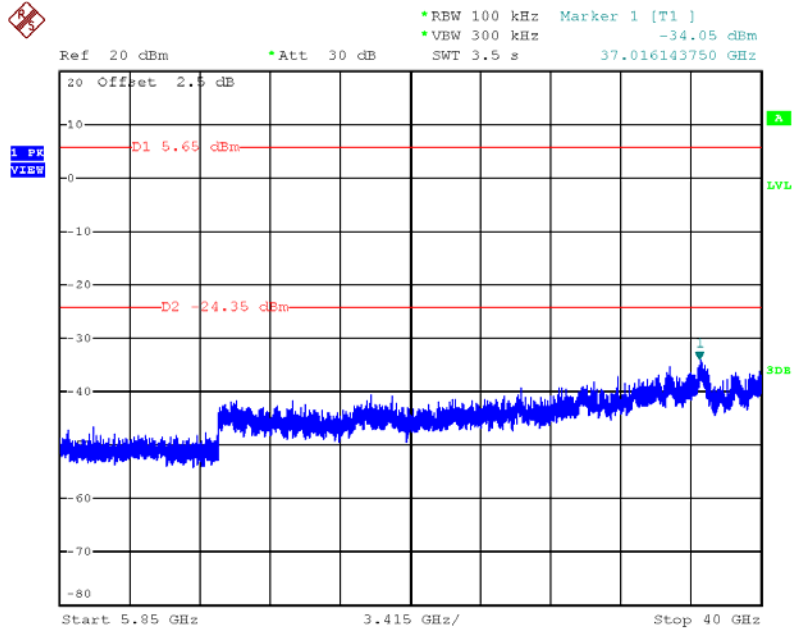

Date: 26.MAR.2013 16:26:42

Plot on Configuration IEEE 802.11n MCS0 20MHz / CH 165 / 30MHz~5725MHz (down 30dBc)

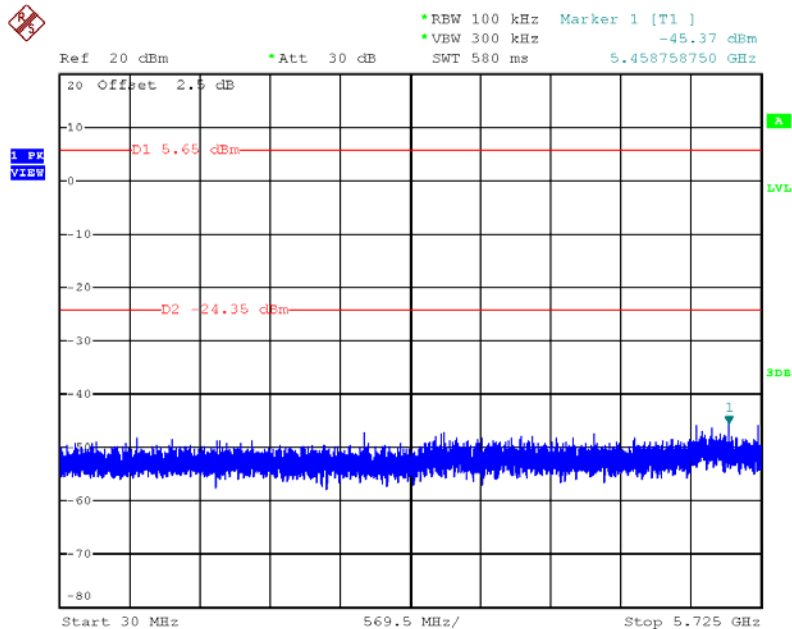

Date: 26.MAR.2013 16:27:55

Plot on Configuration IEEE 802.11n MCS0 20MHz / CH 165 / 5850MHz~40000MHz (down 30dBc)

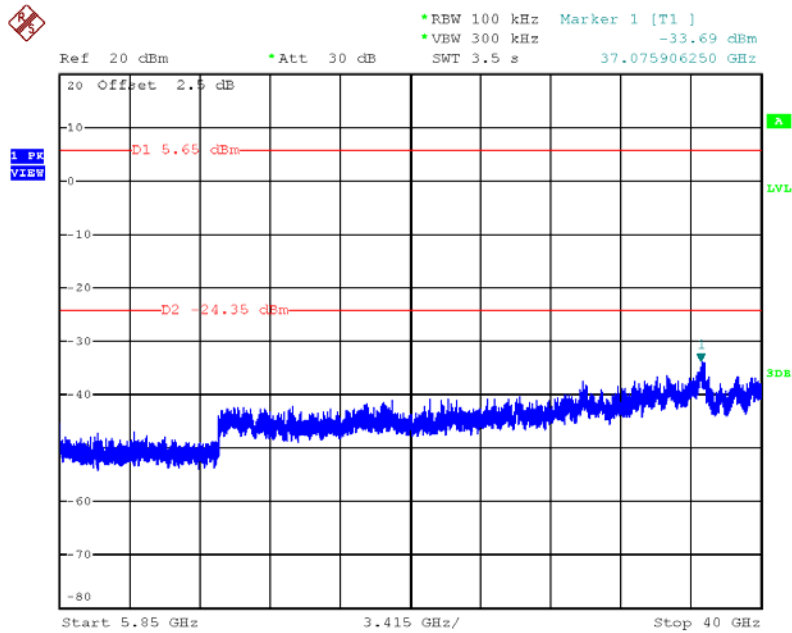

Date: 26.MAR.2013 16:27:39

Plot on Configuration IEEE 802.11n MCS0 40MHz / Reference Level

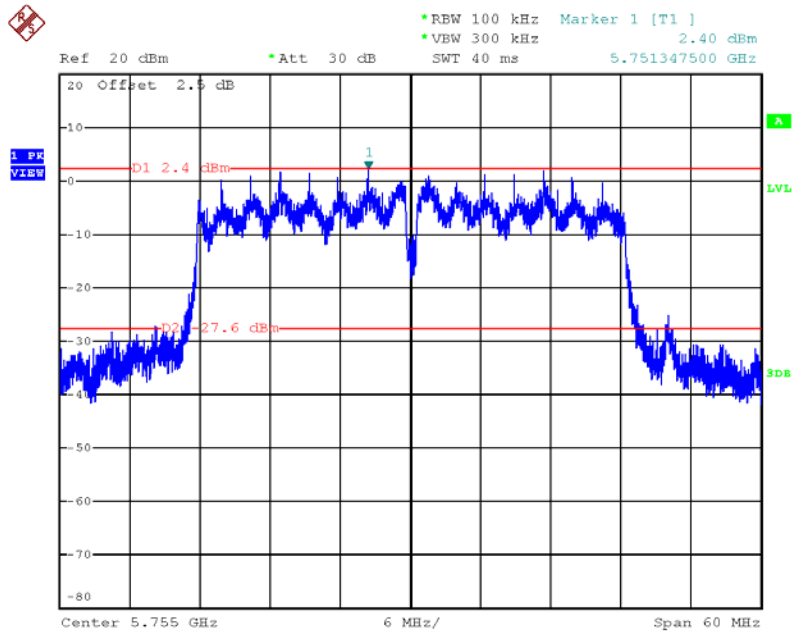

Date: 26.MAR.2013 16:29:14

Plot on Configuration IEEE 802.11n MCS0 40MHz / CH 151 / 30MHz~5725MHz (down 30dBc)

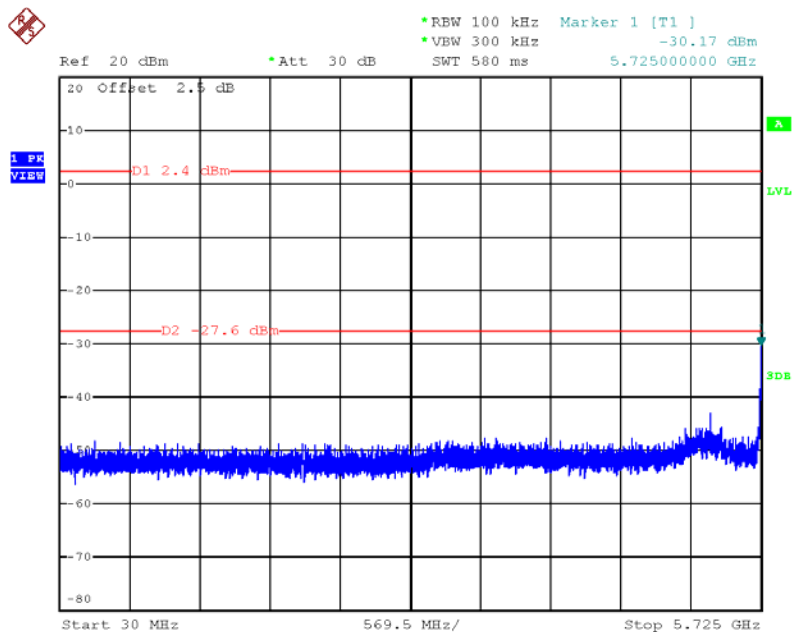

Date: 26.MAR.2013 16:29:52

Plot on Configuration IEEE 802.11n MCS0 40MHz / CH 151 / 5850MHz~40000MHz (down 30dBc)

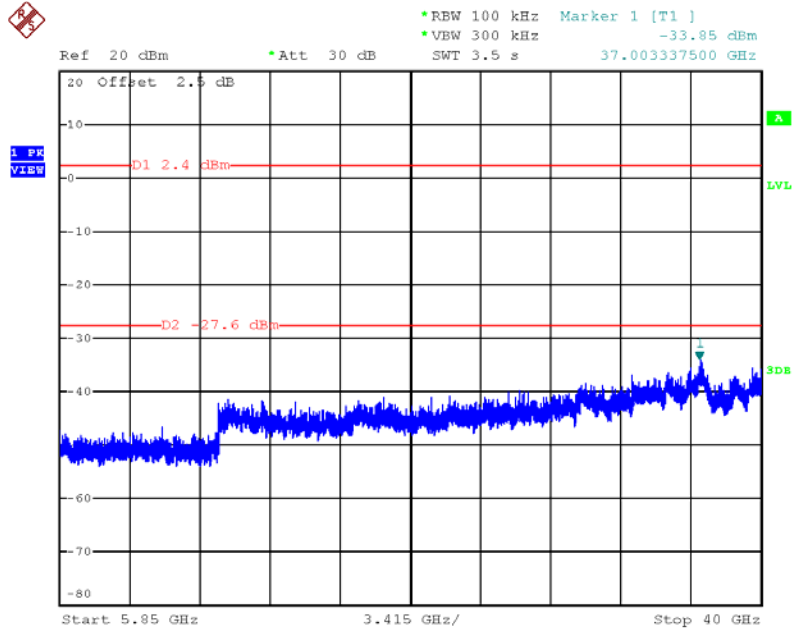

Date: 26.MAR.2013 16:30:07

Plot on Configuration IEEE 802.11n MCS0 40MHz / CH 159 / 30MHz~5725MHz (down 30dBc)

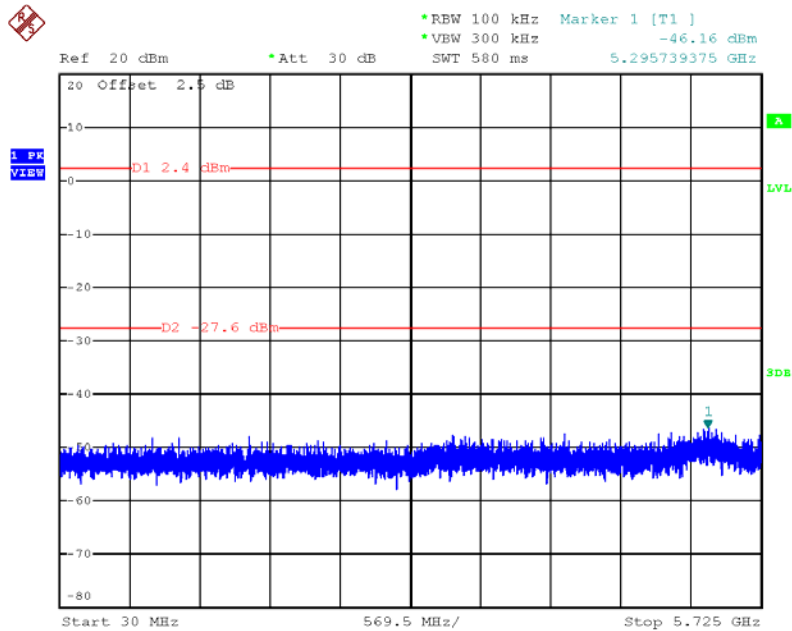

Date: 26.MAR.2013 16:31:11

Plot on Configuration IEEE 802.11n MCS0 40MHz / CH 159 / 5850MHz~40000MHz (down 30dBc)

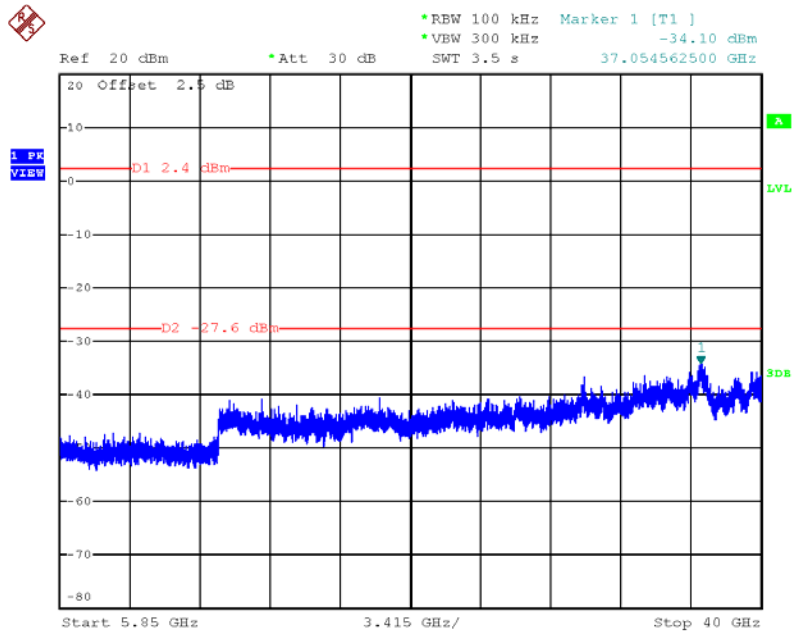

Date: 26.MAR.2013 16:30:57

Plot on Configuration IEEE 802.11b / Reference Level

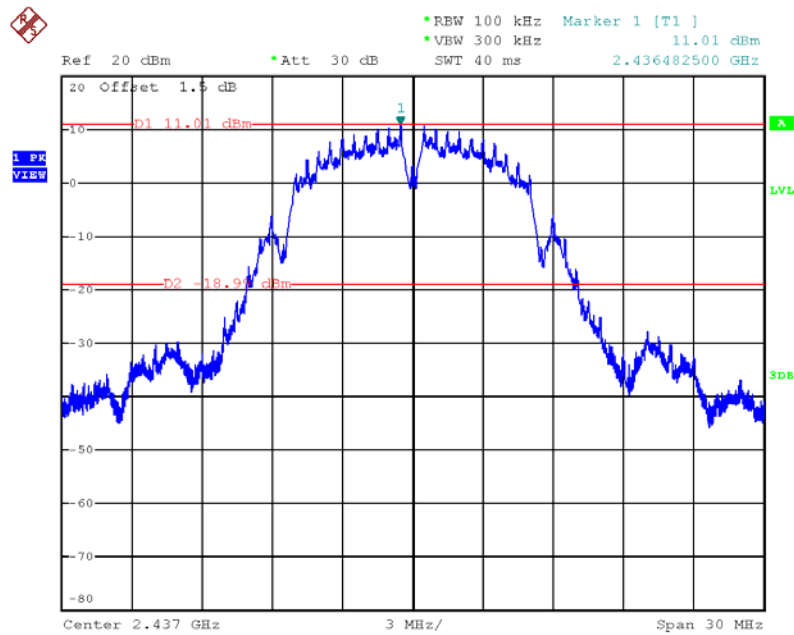

Date: 26.MAR.2013 13:09:24

Plot on Configuration IEEE 802.11b / CH 1 / 30MHz~2400MHz (down 30dBc)

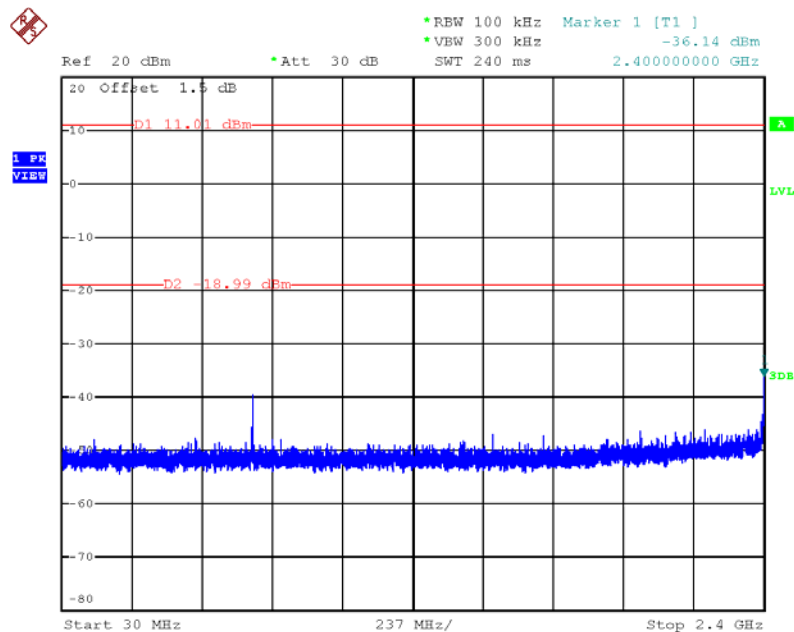

Date: 26.MAR.2013 13:10:32

Plot on Configuration IEEE 802.11b / CH 1 / 2500MHz~26500MHz (down 30dBc)

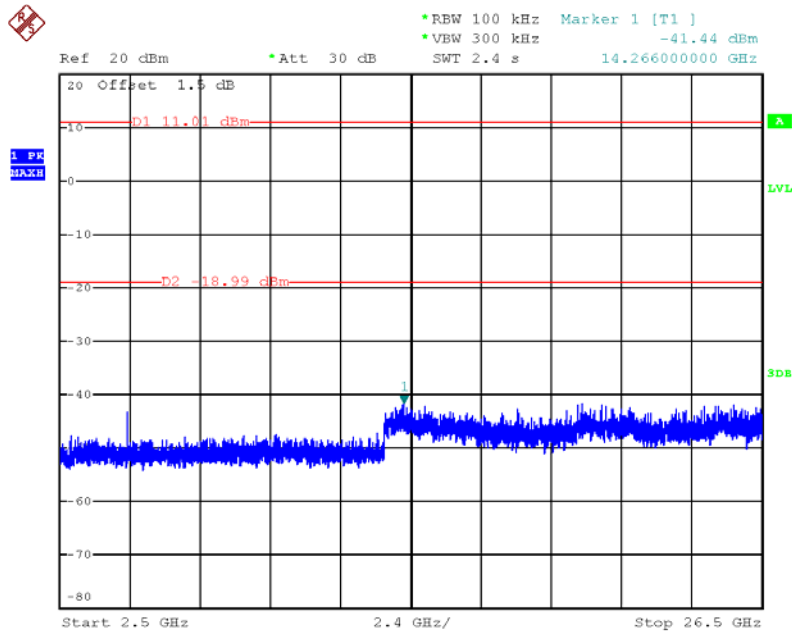

Date: 26.MAR.2013 13:25:57

Plot on Configuration IEEE 802.11b / CH 11 / 30MHz~2400MHz (down 30dBc)

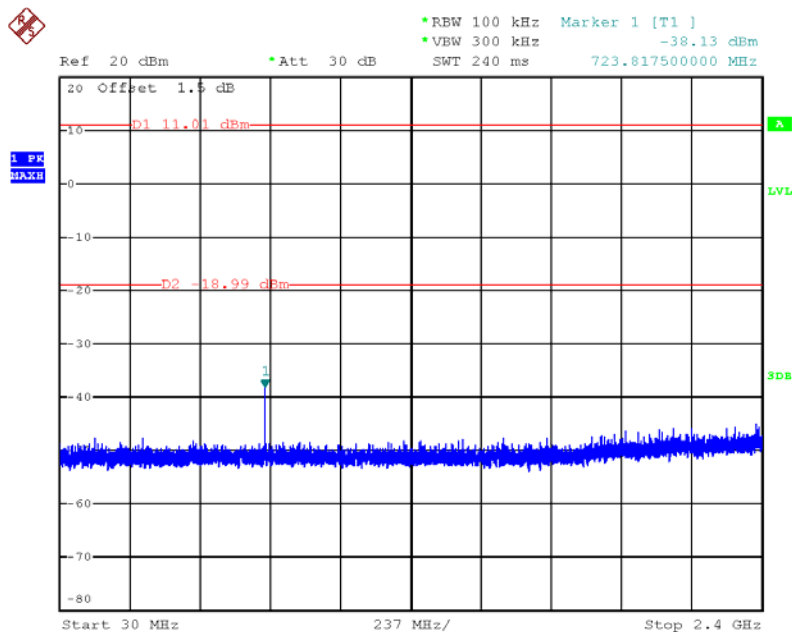

Date: 26.MAR.2013 13:22:04

Plot on Configuration IEEE 802.11b / CH 11 / 2500MHz~26500MHz (down 30dBc)

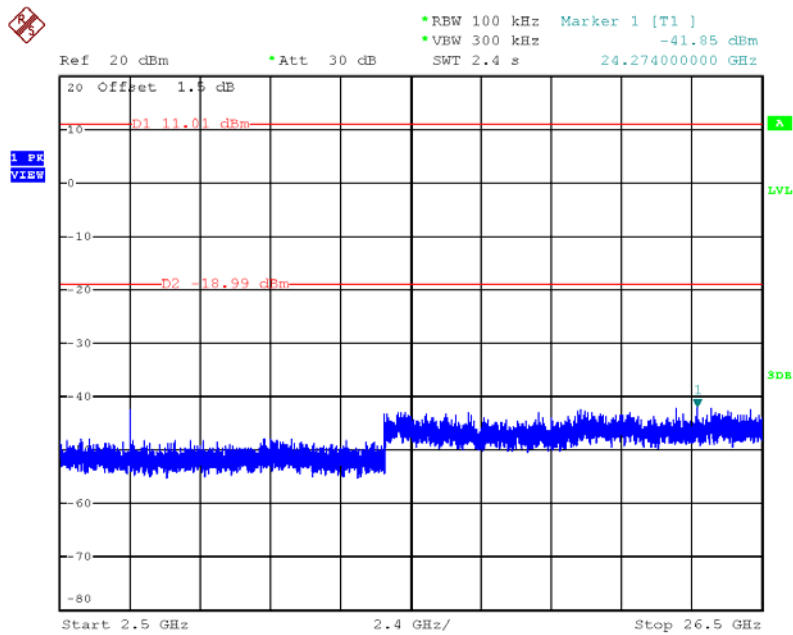

Date: 26.MAR.2013 13:21:23

Plot on Configuration IEEE 802.11g / Reference Level

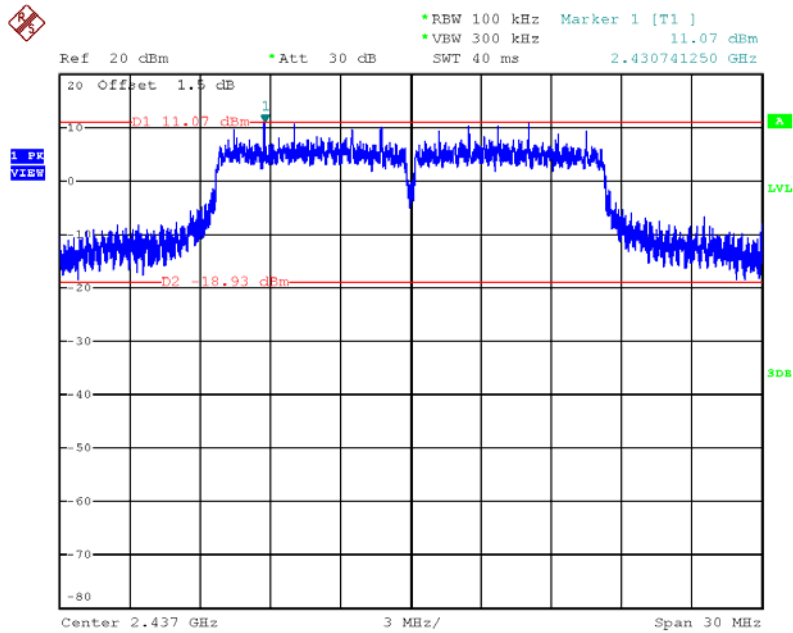

Date: 26.MAR.2013 14:03:13

Plot on Configuration IEEE 802.11g / CH 1 / 30MHz~2400MHz (down 30dBc)

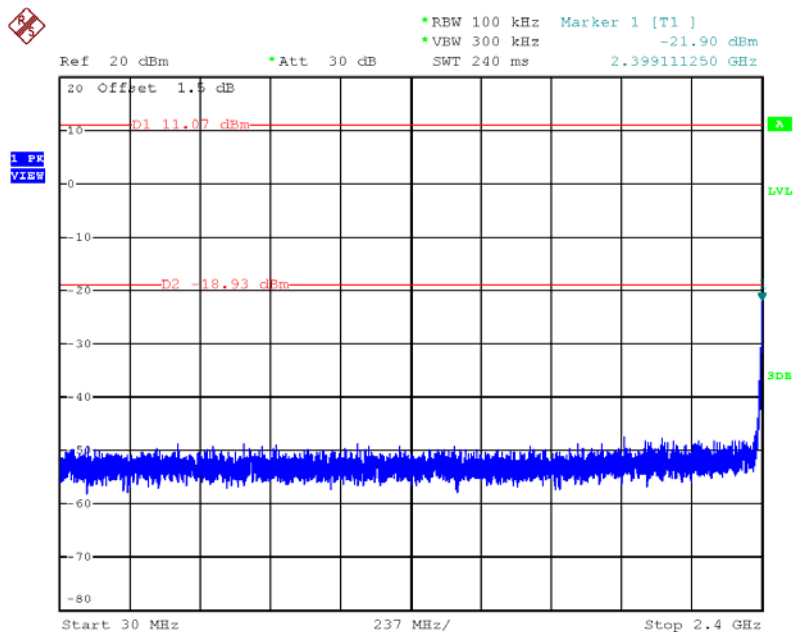

Date: 26.MAR.2013 14:04:42

Plot on Configuration IEEE 802.11g / CH 1 / 2500MHz~26500MHz (down 30dBc)

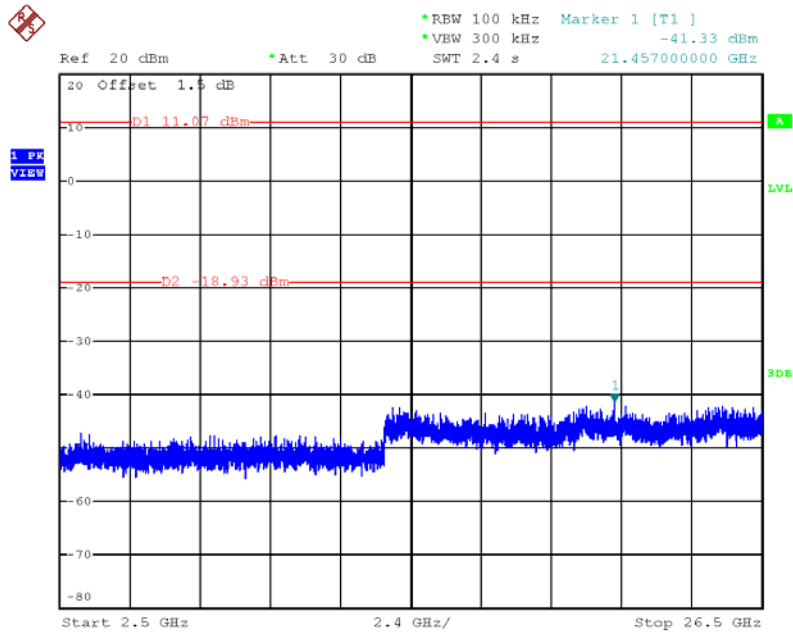

Date: 26.MAR.2013 14:05:24

Plot on Configuration IEEE 802.11g / CH 11 / 30MHz~2400MHz (down 30dBc)

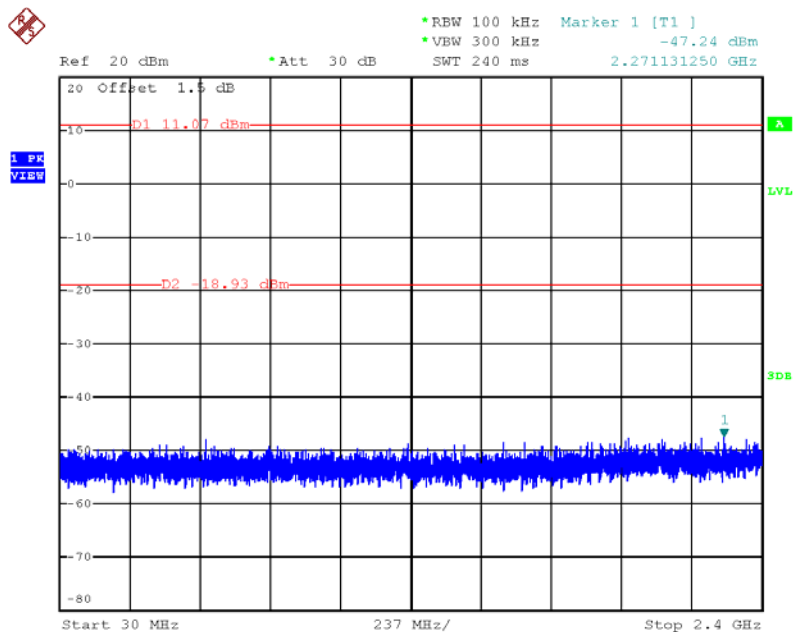

Date: 26.MAR.2013 14:06:46

Plot on Configuration IEEE 802.11g / CH 11 / 2500MHz~26500MHz (down 30dBc)

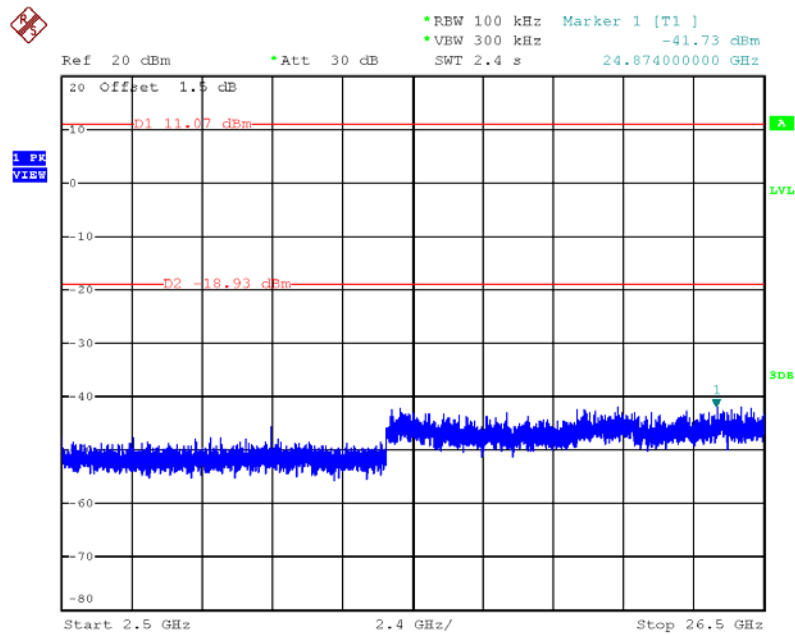

Date: 26.MAR.2013 14:06:19

Plot on Configuration IEEE 802.11a / Reference Level

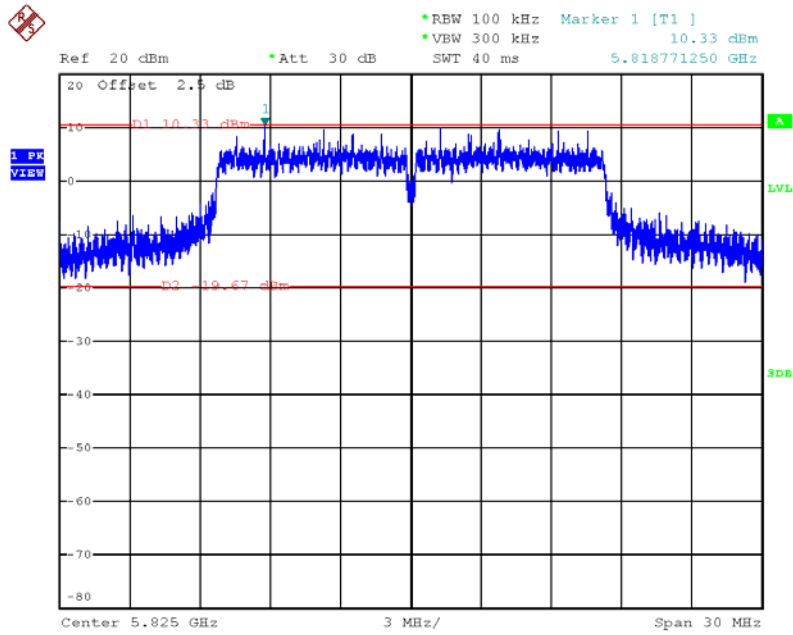

Date: 26.MAR.2013 16:20:27

Plot on Configuration IEEE 802.11a / CH 149 / 30MHz~5725MHz (down 30dBc)

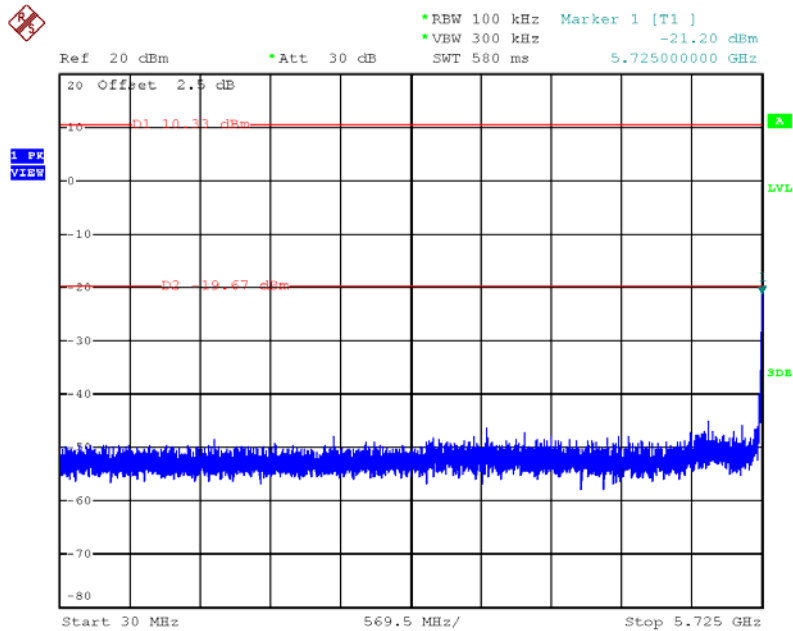

Date: 26.MAR.2013 16:21:13

Plot on Configuration IEEE 802.11a / CH 149 / 5850MHz~4000MHz (down 30dBc)

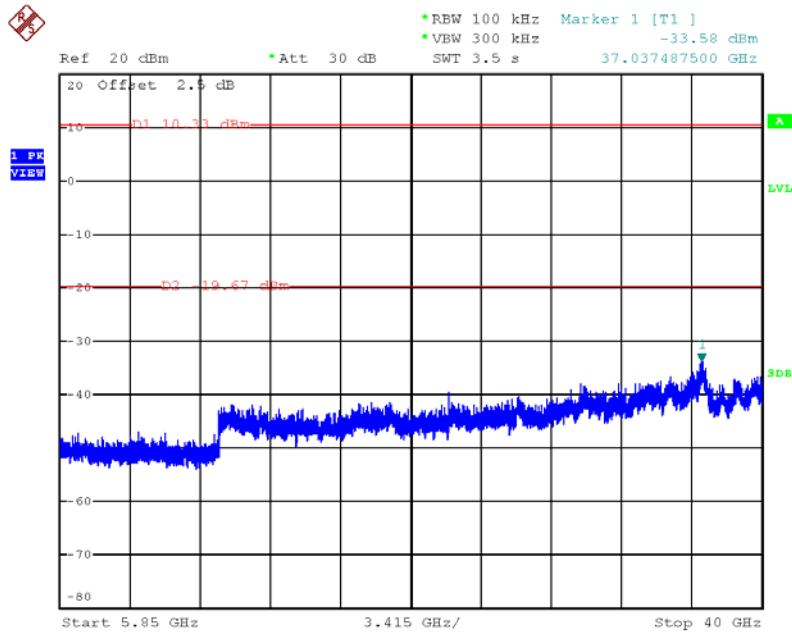

Date: 26.MAR.2013 16:21:53

Plot on Configuration IEEE 802.11a / CH 165 / 30MHz~5725MHz (down 30dBc)

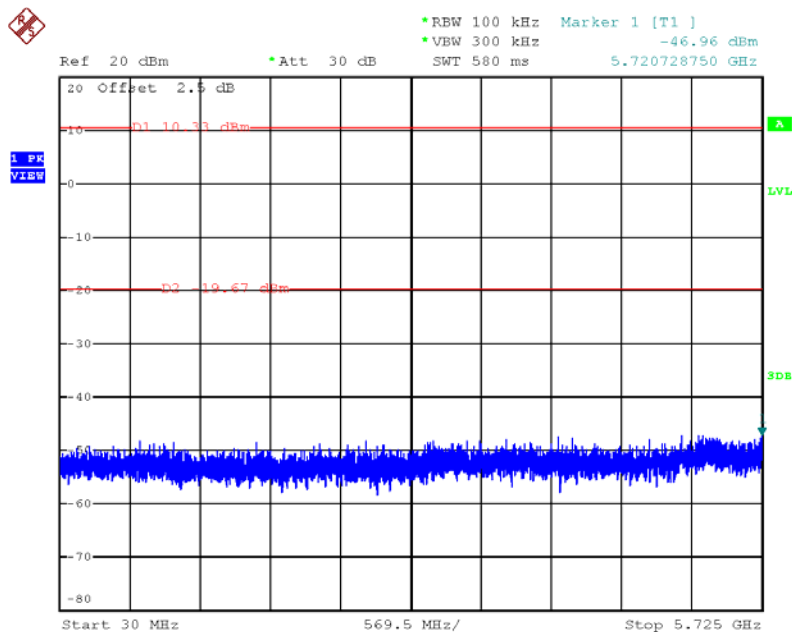

Date: 26.MAR.2013 16:23:47

Plot on Configuration IEEE 802.11a / CH 165 / 5850MHz~4000MHz (down 30dBc)

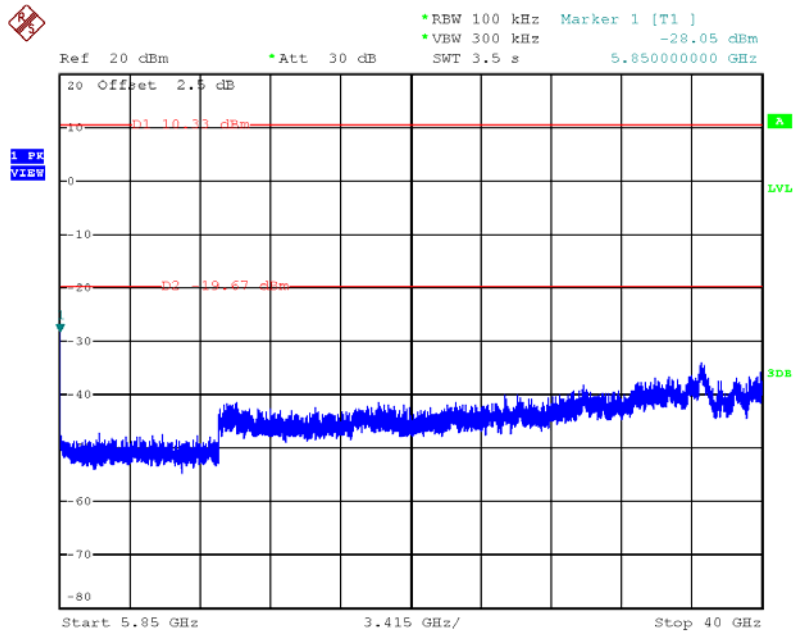

Date: 26.MAR.2013 16:22:39

4.7. Antenna Requirements

4.7.1. Limit

Except for special regulations, the Low-power Radio-frequency Devices must not be equipped with any jacket for installing an antenna with extension cable. An intentional radiator shall be designed to ensure that no antenna other than that furnished by the responsible party shall be used with the device. The use of a permanently attached antenna or of an antenna that uses a unique coupling to the intentional radiator shall be considered sufficient to comply with the provisions of this Section. The manufacturer may design the unit so that the user can replace a broken antenna, but the use of a standard antenna jack or electrical connector is prohibited. Further, this requirement does not apply to intentional radiators that must be professionally installed.

4.7.2. Antenna Connector Construction

Please refer to section 3.3 in this test report; antenna connector complied with the requirements.

5. LIST OF MEASURING EQUIPMENTS

Instrument	Manufacturer	Model No.	Serial No.	Characteristics	Calibration Date	Remark
BILOG ANTENNA	Schaffner	CBL6112D	22021	20MHz ~ 2GHz	Jan. 11, 2013	Radiation (03CH01-CB)
Loop Antenna	Teseq	HLA 6120	24155	9 kHz - 30 MHz	Nov. 05, 2012*	Radiation (03CH01-CB)
Horn Antenna	EMCO	3115	00075790	750MHz~18GHz	Nov. 27, 2012	Radiation (03CH01-CB)
Horn Antenna	SCHWARZBEAK	BBHA 9170	BBHA9170252	15GHz ~ 40GHz	Nov. 23, 2012	Radiation (03CH01-CB)
Pre-Amplifier	Agilent	8447D	2944A10991	0.1MHz ~ 1.3GHz	Nov. 27, 2012	Radiation (03CH01-CB)
Pre-Amplifier	Agilent	8449B	3008A02310	1GHz ~ 26.5GHz	Nov. 23, 2012	Radiation (03CH01-CB)
Pre-Amplifier	WM	TF-130N-R1	923365	26.5GHz ~ 40GHz	Jul. 31, 2012	Radiation (03CH01-CB)
Spectrum analyzer	R&S	FSP40	100056	9KHz~40GHz	Nov. 16, 2012	Radiation (03CH01-CB)
EMI Test Receiver	R&S	ESCS 30	100355	9KHz ~ 2.75GHz	Mar. 20, 2012	Radiation (03CH01-CB)
Turn Table	INN CO	CO 2000	N/A	0 ~ 360 degree	N.C.R	Radiation (03CH01-CB)
Antenna Mast	INN CO	CO2000	N/A	1 m - 4 m	N.C.R	Radiation (03CH01-CB)
RF Cable-low	Woken	Low Cable-1	N/A	30 MHz - 1 GHz	Nov. 18, 2012	Radiation (03CH01-CB)
RF Cable-high	Woken	High Cable-1	N/A	1 GHz - 26.5 GHz	Nov. 18, 2012	Radiation (03CH01-CB)
RF Cable-high	Woken	High Cable-2	N/A	1 GHz - 26.5 GHz	Nov. 18, 2012	Radiation (03CH01-CB)
RF Cable-high	Woken	High Cable-3	N/A	1 GHz - 40 GHz	Nov. 18, 2012	Radiation (03CH01-CB)
RF Cable-high	Woken	High Cable-4	N/A	1 GHz - 40 GHz	Nov. 18, 2012	Radiation (03CH01-CB)
Signal analyzer	R&S	FSV40	100979	9KHz~40GHz	Oct. 08, 2012	Conducted (TH01-CB)
Temp. and Humidity Chamber	Ten Billion	TTH-D3SP	TBN-931011	-30~100 degree	Jun. 05, 2012	Conducted (TH01-CB)
RF Power Divider	Woken	2 Way	0120A02056002D	2GHz ~ 18GHz	Nov. 18, 2012	Conducted (TH01-CB)
RF Power Divider	Woken	3 Way	MDC2366	2GHz ~ 18GHz	Nov. 18, 2012	Conducted (TH01-CB)
RF Power Divider	Woken	4 Way	0120A04056002D	2GHz ~ 18GHz	Nov. 18, 2012	Conducted (TH01-CB)
RF Cable-high	Woken	High Cable-7	-	1 GHz - 26.5 GHz	Nov. 19, 2012	Conducted (TH01-CB)
RF Cable-high	Woken	High Cable-8	-	1 GHz - 26.5 GHz	Nov. 19, 2012	Conducted (TH01-CB)
RF Cable-high	Woken	High Cable-9	-	1 GHz - 26.5 GHz	Nov. 19, 2012	Conducted (TH01-CB)
RF Cable-high	Woken	High Cable-10	-	1 GHz - 26.5 GHz	Nov. 19, 2012	Conducted (TH01-CB)
RF Cable-high	Woken	High Cable-11	-	1 GHz - 26.5 GHz	Nov. 19, 2012	Conducted (TH01-CB)
Power Sensor	Anritsu	MA2411B	0917223	300MHz~40GHz	Nov. 28, 2012	Conducted (TH01-CB)
Power Meter	Anritsu	ML2495A	1035008	300MHz~40GHz	Nov. 27, 2012	Conducted (TH01-CB)
EMI Test Receiver	R&S	ESCS 30	100377	9kHz ~ 2.75GHz	Oct. 23, 2012	Conduction (CO01-CB)

Instrument	Manufacturer	Model No.	Serial No.	Characteristics	Calibration Date	Remark
LISN	F.C.C.	FCC-LISN-50-16-2	04083	150kHz ~ 100MHz	Nov. 26, 2012	Conduction (CO01-CB)
V- LISN	Schwarzbeck	NSLK 8127	8127-478	9kHz ~ 30MHz	Jun. 22, 2012	Conduction (CO01-CB)
Impulsbegrenzer Pulse Limiter	Rohde&Schwarz	ESH3-Z2	100430	9kHz~30MHz	Feb. 21, 2013	Conduction (CO01-CB)
COND Cable	Woken	Cable	01	0.15MHz~30MHz	Dec. 04, 2012	Conduction (CO01-CB)
Software	Audix	E3	5.410e	-	-	Conduction (CO01-CB)

Note: Calibration Interval of instruments listed above is one year.

“*” Calibration Interval of instruments listed above is two years.

N.C.R. means Non-Calibration required.

6. TEST LOCATION

SHIJR	ADD : 6Fl., No. 106, Sec. 1, Shintai 5th Rd., Shijr City, Taipei, Taiwan 221, R.O.C. TEL : 886-2-2696-2468 FAX : 886-2-2696-2255
HWA YA	ADD : No. 52, Hwa Ya 1st Rd., Kwei-Shan Hsiang, Tao Yuan Hsien, Taiwan, R.O.C. TEL : 886-3-327-3456 FAX : 886-3-318-0055
LINKOU	ADD : No. 30-2, Dingfu Tsuen, Linkou Shiang, Taipei, Taiwan 244, R.O.C TEL : 886-2-2601-1640 FAX : 886-2-2601-1695
DUNGHU	ADD : No. 3, Lane 238, Kangle St., Neihu Chiu, Taipei, Taiwan 114, R.O.C. TEL : 886-2-2631-4739 FAX : 886-2-2631-9740
JUNGHE	ADD : 7Fl., No. 758, Jungjeng Rd., Junghe City, Taipei, Taiwan 235, R.O.C. TEL : 886-2-8227-2020 FAX : 886-2-8227-2626
NEIHU	ADD : 4Fl., No. 339, Hsin Hu 2 nd Rd., Taipei 114, Taiwan, R.O.C. TEL : 886-2-2794-8886 FAX : 886-2-2794-9777
JHUBEI	ADD : No.8, Lane 724, Bo-ai St., Jhubei City, HsinChu County 302, Taiwan, R.O.C. TEL : 886-3-656-9065 FAX : 886-3-656-9085