

VIII. Section 15.407(a)(6): Peak Excursion Measurement

8.1 Test Condition & Setup

The tests below are running with the EUT transmitter set at high power mode. The EUT is needed to force selection of output power level and channel number. While testing, the EUT was set to transmit continuously and to be tested by the contact manner with the spectrum analyzer.

The test is performed accordance with FCC Public Notice: APPENDIX A Guidelines for Assessing Unlicensed National Information Infrastructure (U-NII) Devices – Part 15, Subpart E, August 2002.(FCC Public Notice DA02-2138A1)

The transmitter output operates continuously therefore 2nd trace of Method # 3 is used.

8.2 Test Instruments Configuration

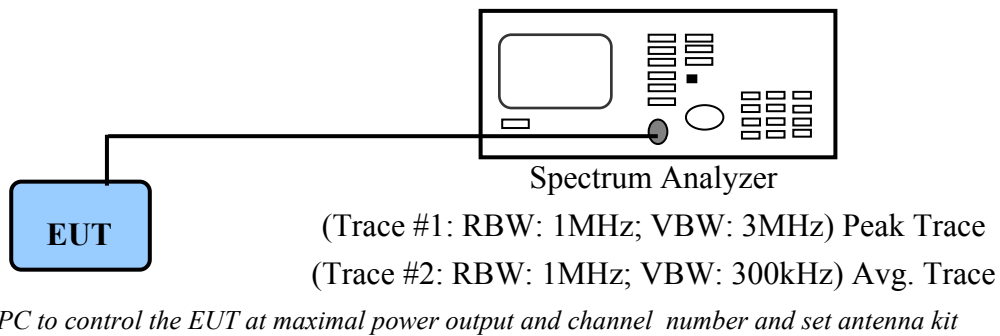

8.3 List of Test Instruments

Instrument Name	Model No.	Brand	Serial No.	Next time
Spectrum Analyzer	MS2665C	ANRITSU	6200175476	12/19/09

8.4 Test Result of Peak Excursion

The following table shows a summary of the test results of the Peak Excursion.

IEEE 802.11a: Operated at 5150 MHz to 5250 MHz

Antenna#1

Frequency (MHz)	Peak Excursion (dB)	Limit (dB)	Margin (dB)
5180	8.53	13.00	-4.47
5200	8.40	13.00	-4.60
5240	7.76	13.00	-5.24

Antenna#2

Frequency (MHz)	Peak Excursion (dB)	Limit (dB)	Margin (dB)
5180	8.43	13.00	-4.57
5200	8.64	13.00	-4.36
5240	7.92	13.00	-5.08

IEEE 802.11a 20M

Antenna#1

Frequency (MHz)	Peak Excursion (dB)	Limit (dB)	Margin (dB)
5180	7.40	13.00	-5.60
5200	7.95	13.00	-5.05
5240	7.37	13.00	-5.63

Antenna#2

Frequency (MHz)	Peak Excursion (dB)	Limit (dB)	Margin (dB)
5180	7.88	13.00	-5.12
5200	7.80	13.00	-5.20
5240	8.21	13.00	-4.79

IEEE 802.11a 40M

Antenna#1

Frequency (MHz)	Peak Excursion (dB)	Limit (dB)	Margin (dB)
5190	7.19	13.00	-5.81
5230	7.69	13.00	-5.31

Antenna#2

Frequency (MHz)	Peak Excursion (dB)	Limit (dB)	Margin (dB)
5190	7.15	13.00	-5.85
5230	6.96	13.00	-6.04

IEEE 802.11a: Operated at 5725 MHz to 5825 MHz

Antenna#1

Frequency (MHz)	Peak Excursion (dB)	Limit (dB)	Margin (dB)
5745	8.56	13.00	-4.44
5785	8.62	13.00	-4.38
5805	8.68	13.00	-4.32

Antenna#2

Frequency (MHz)	Peak Excursion (dB)	Limit (dB)	Margin (dB)
5745	8.89	13.00	-4.11
5785	8.82	13.00	-4.18
5805	8.75	13.00	-4.25

IEEE 802.11a 20M

Antenna#1

Frequency (MHz)	Peak Excursion (dB)	Limit (dB)	Margin (dB)
5745	7.21	13.00	-5.79
5785	7.18	13.00	-5.82
5805	7.38	13.00	-5.62

Antenna#2

Frequency (MHz)	Peak Excursion (dB)	Limit (dB)	Margin (dB)
5745	8.20	13.00	-4.80
5785	7.39	13.00	-5.61
5805	8.26	13.00	-4.74

IEEE 802.11a 40M

Antenna#1

Frequency (MHz)	Peak Excursion (dB)	Limit (dB)	Margin (dB)
5755	6.94	13.00	-6.06
5795	7.37	13.00	-5.63

Antenna#2

Frequency (MHz)	Peak Excursion (dB)	Limit (dB)	Margin (dB)
5755	7.28	13.00	-5.72
5795	6.51	13.00	-6.49

Note:

1. The following pages show the results of spectrum reading.

Peak Excursion for IEEE 802.11a, 5180MHz

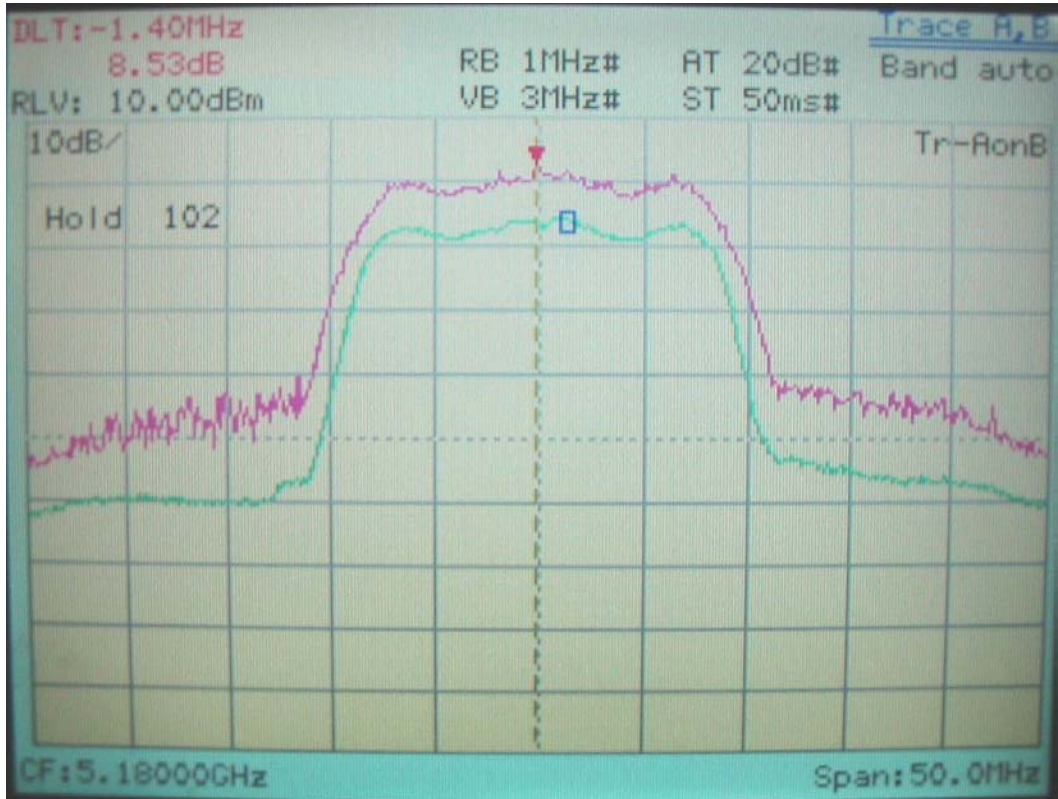

Ant#1

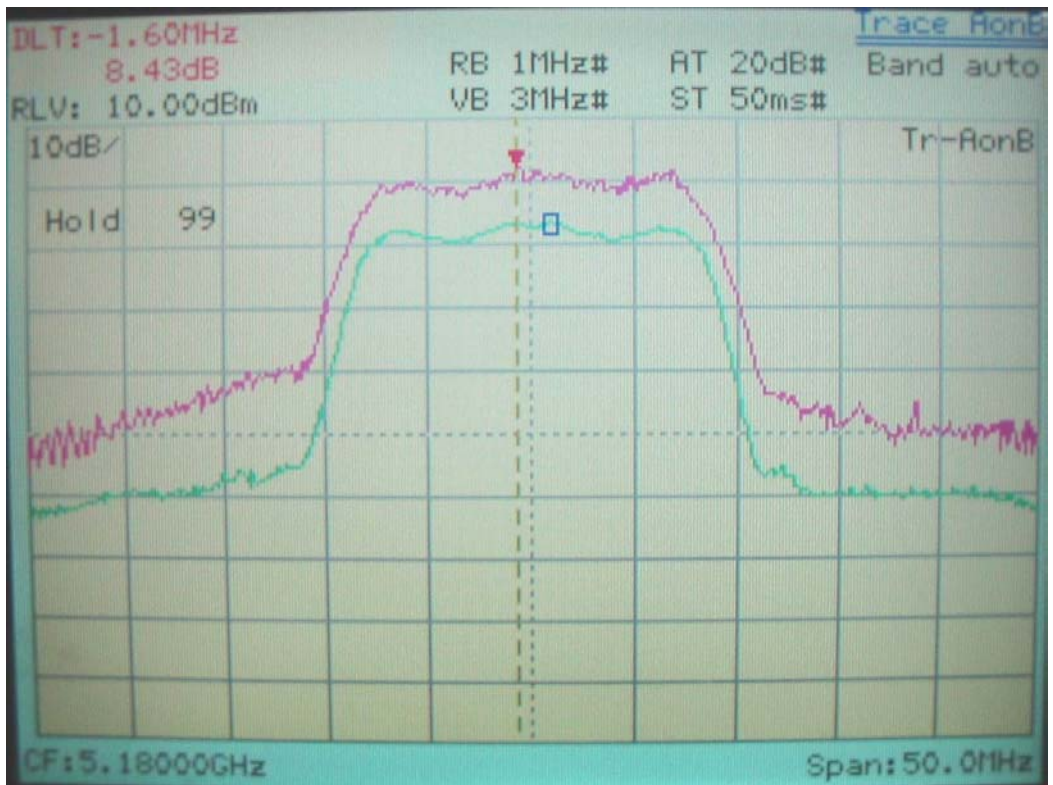

Ant#2

Peak Excursion for IEEE 802.11a, 5200MHz

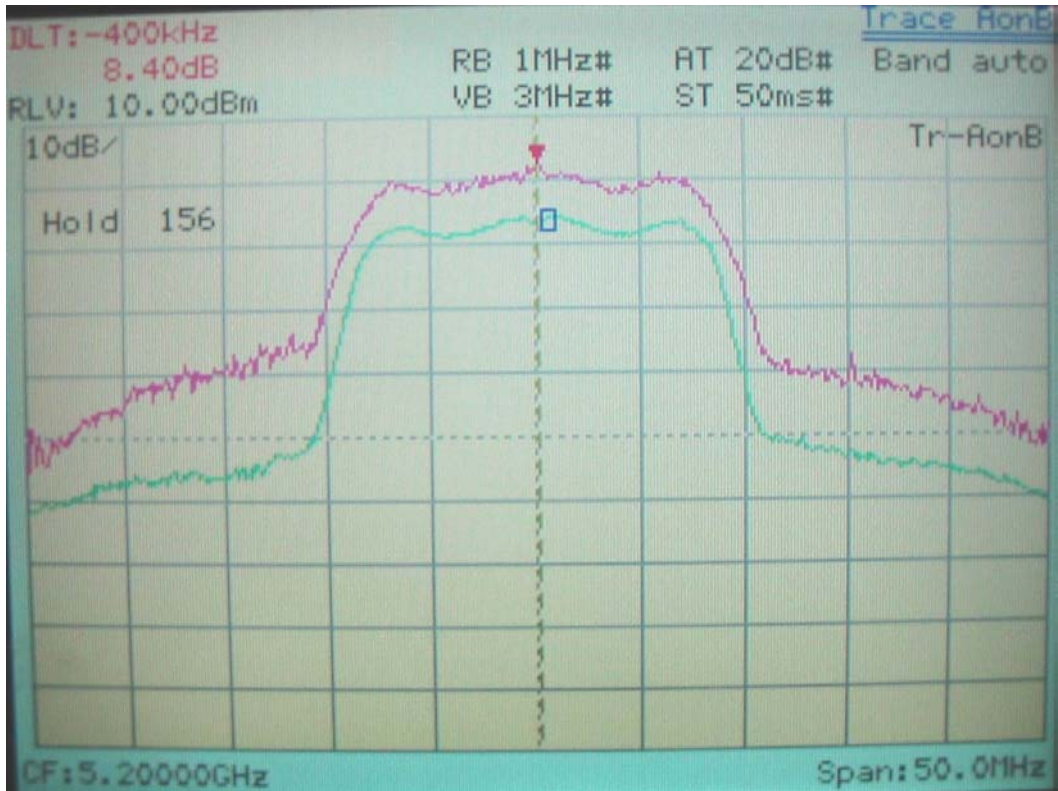

Ant#1



Ant#2

Peak Excursion for IEEE 802.11a, 5240MHz

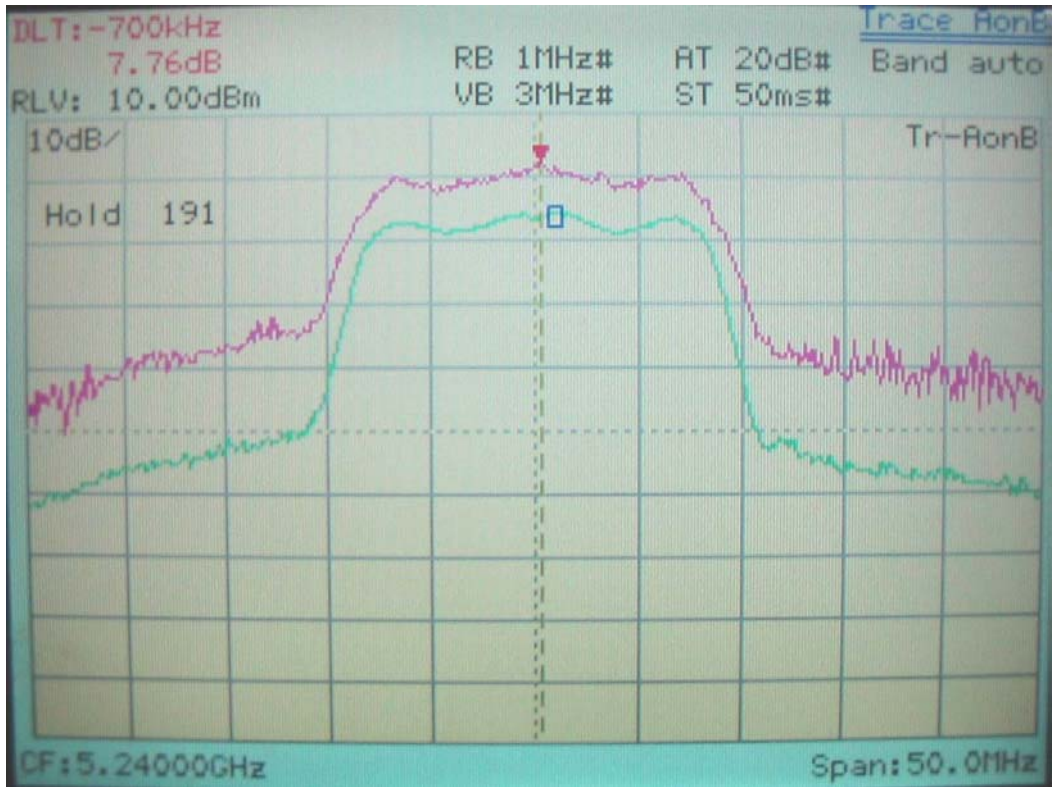

Ant#1

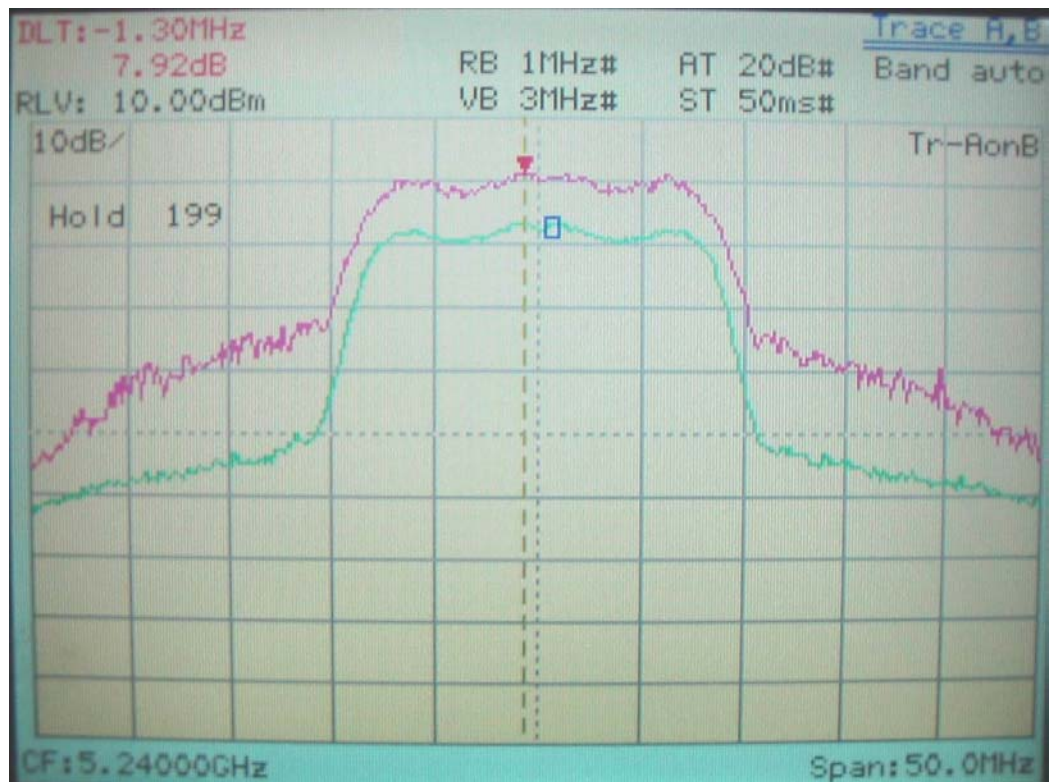

Ant#2

Peak Excursion for IEEE 802.11a 20M, 5180MHz

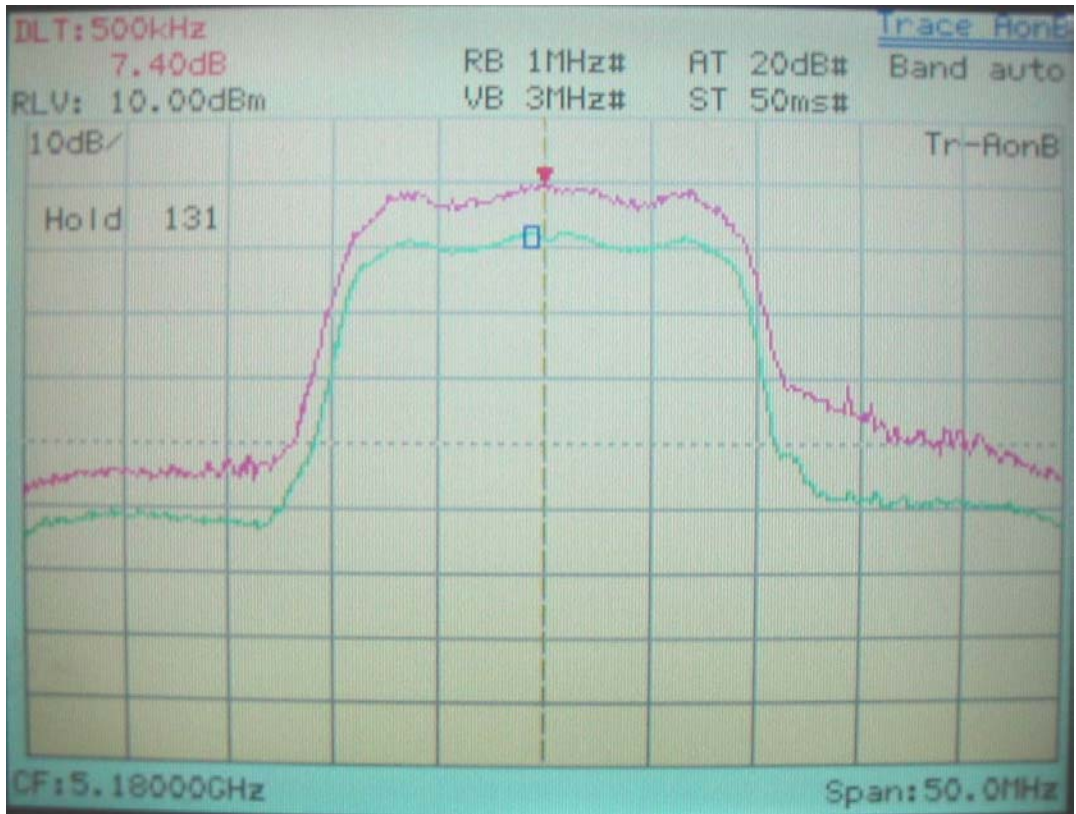

Ant#1

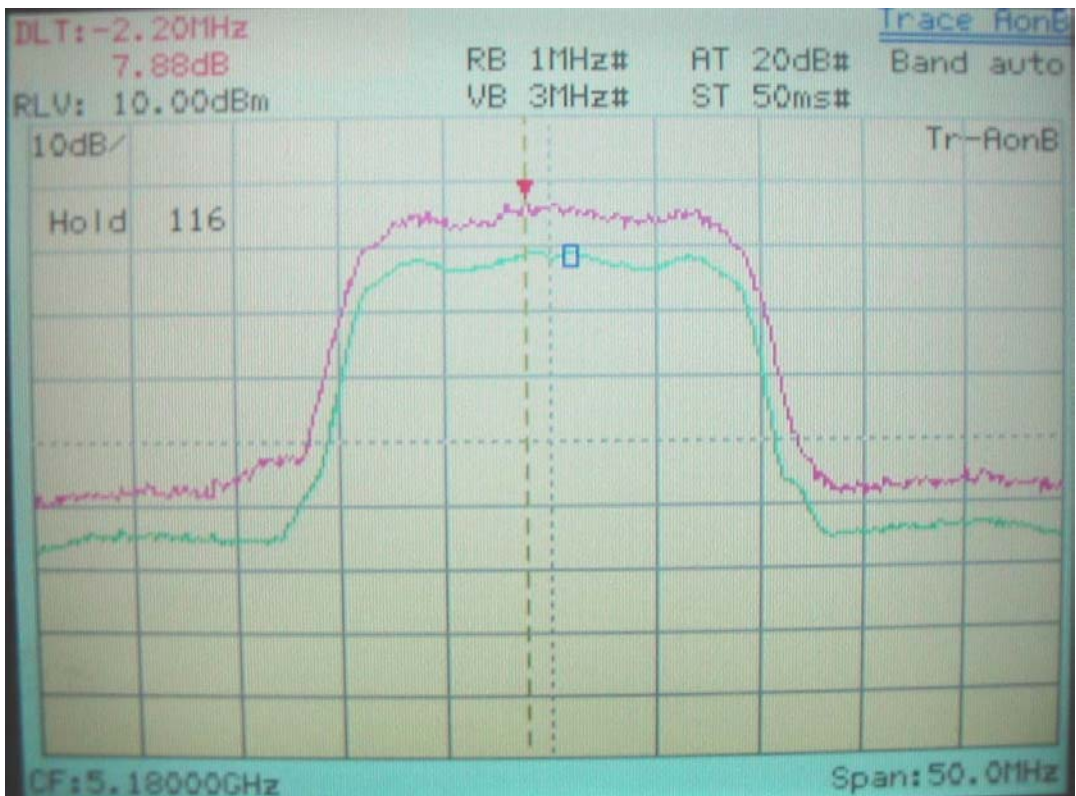

Ant#2

Peak Excursion for IEEE 802.11a 20M, 5200MHz

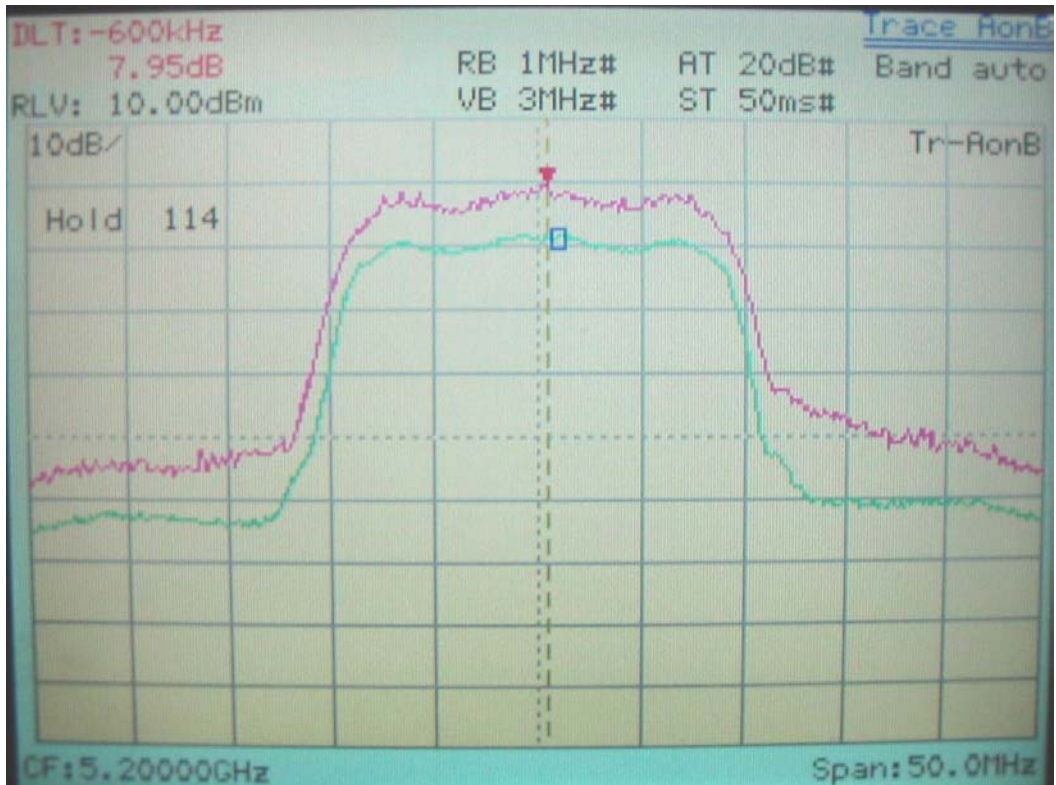

Ant#1

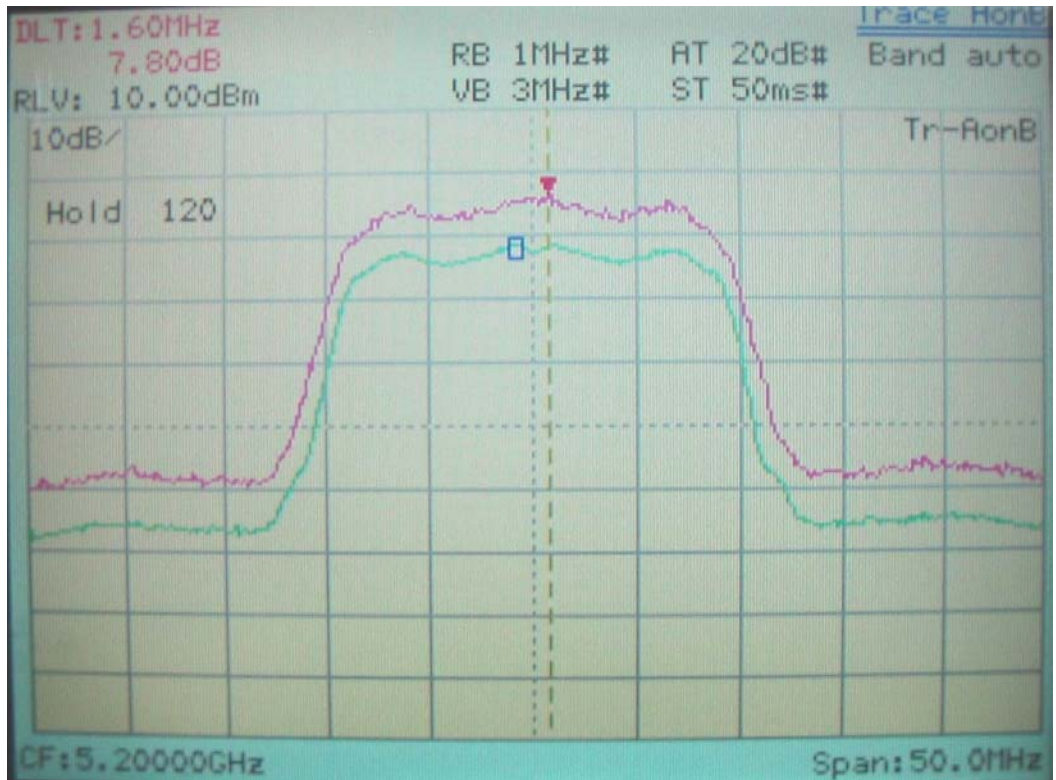

Ant#2

Peak Excursion for IEEE 802.11a 20M, 5240MHz



Ant#1

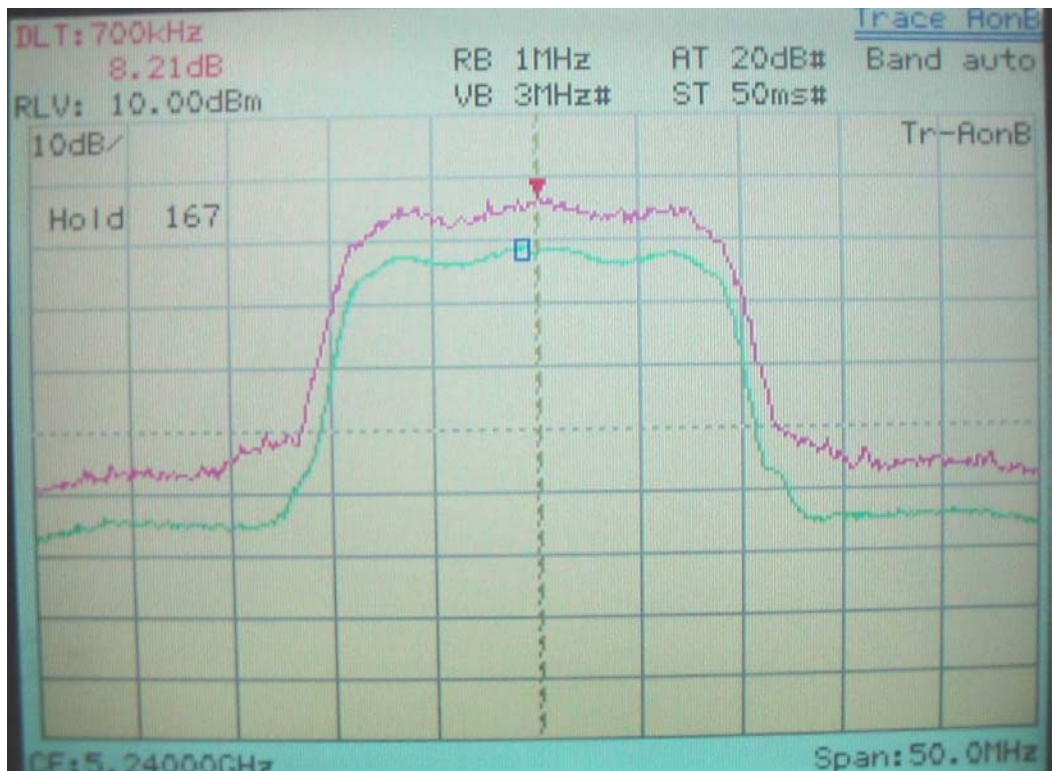

Ant#2

Peak Excursion for IEEE 802.11a 40M, 5190MHz



Ant#1



Ant#2

Peak Excursion for IEEE 802.11a 40M, 5230MHz

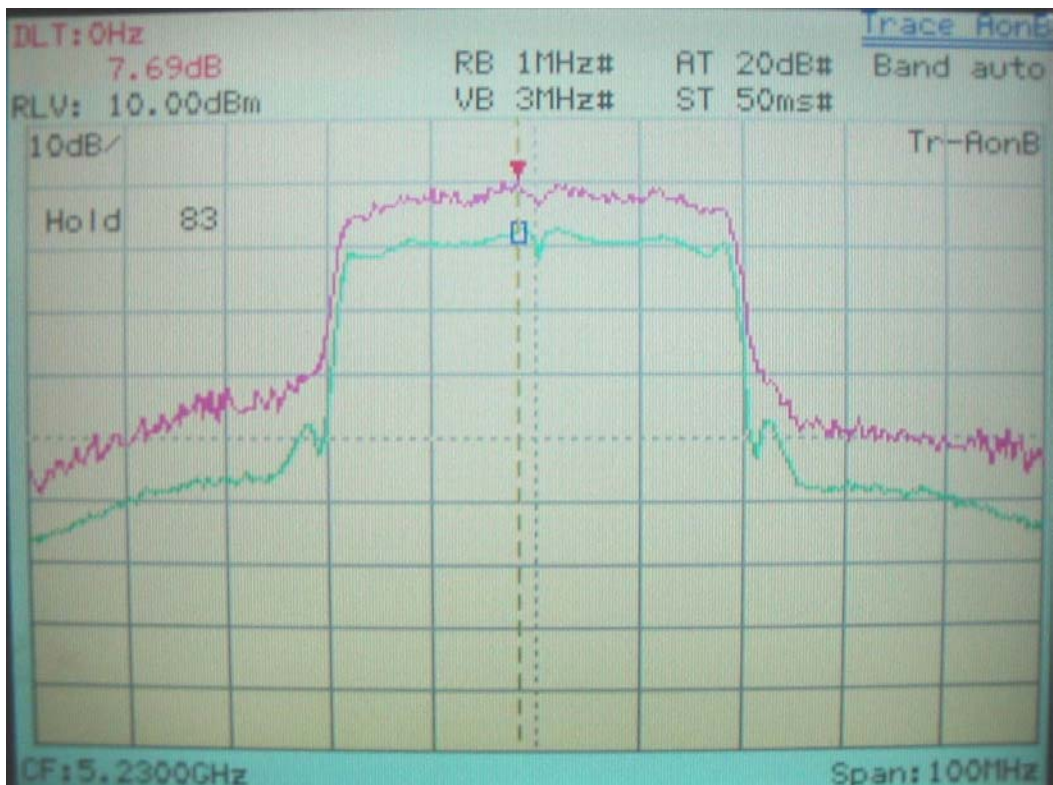

Ant#1

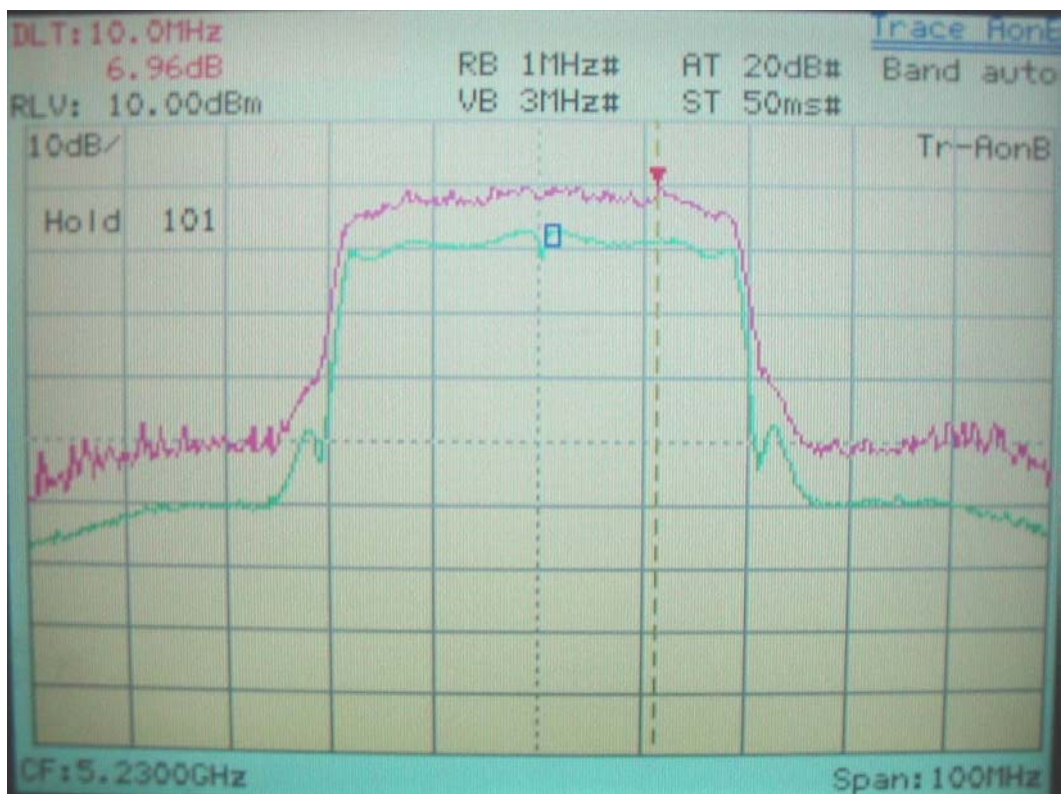

Ant#2

Peak Excursion for IEEE 802.11a, 5745MHz

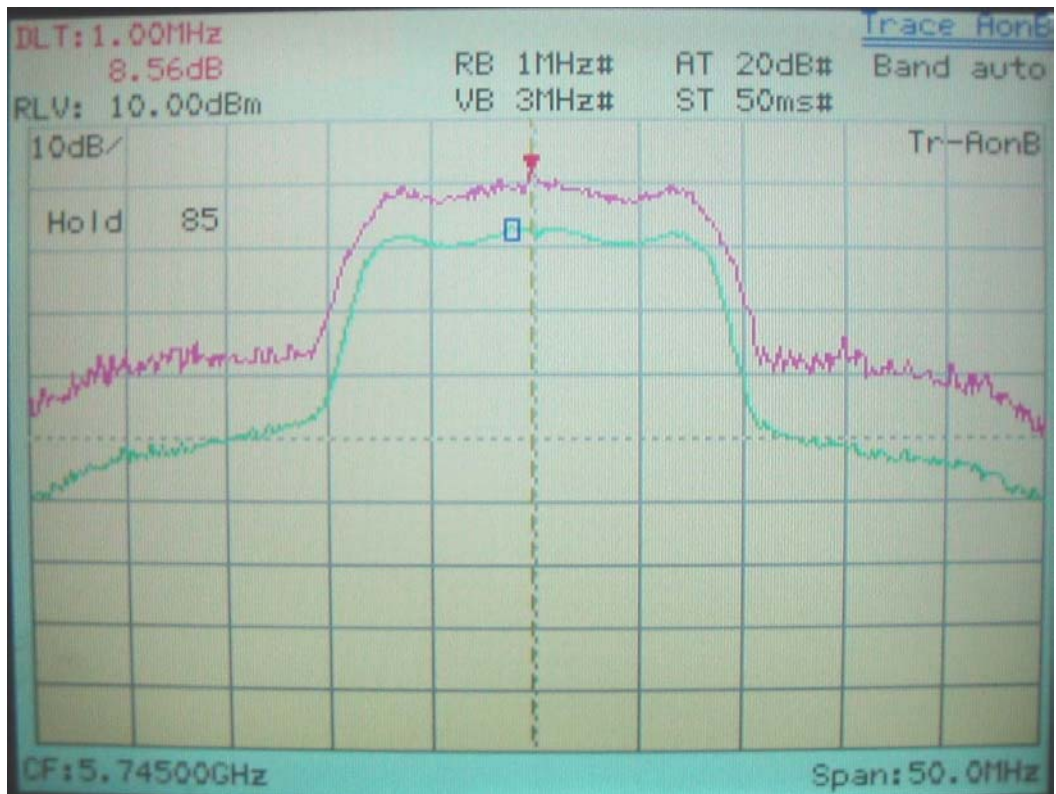

Ant#1

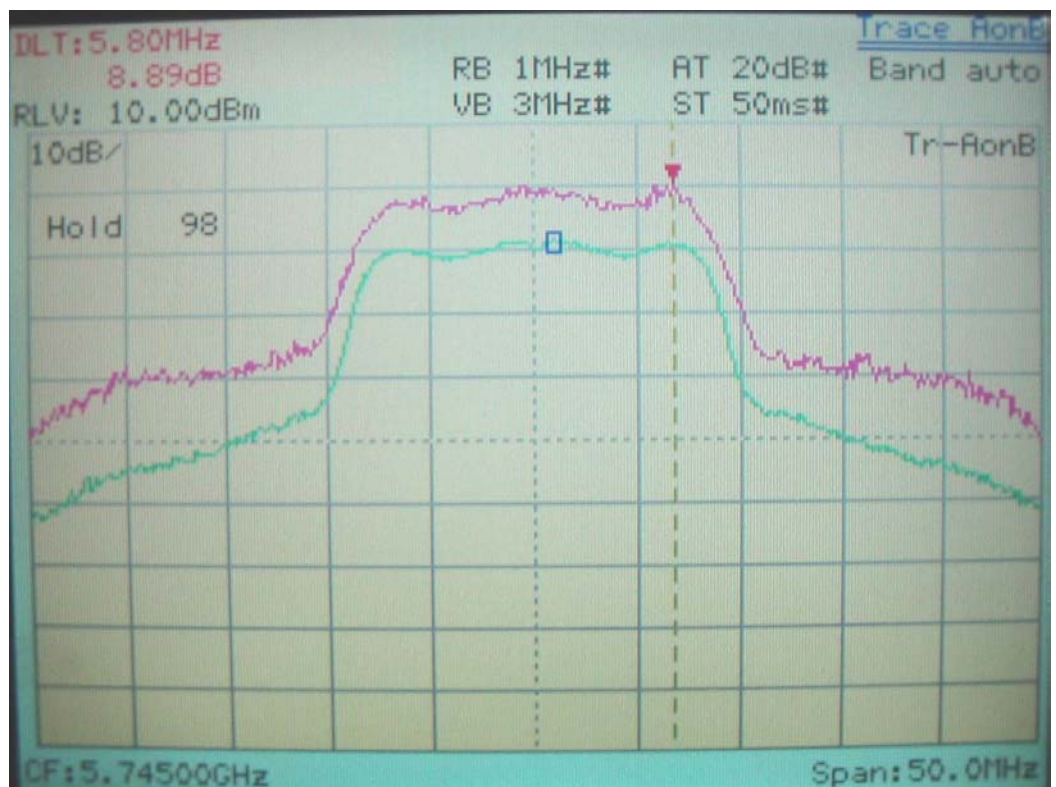

Ant#2

Peak Excursion for IEEE 802.11a, 5785MHz

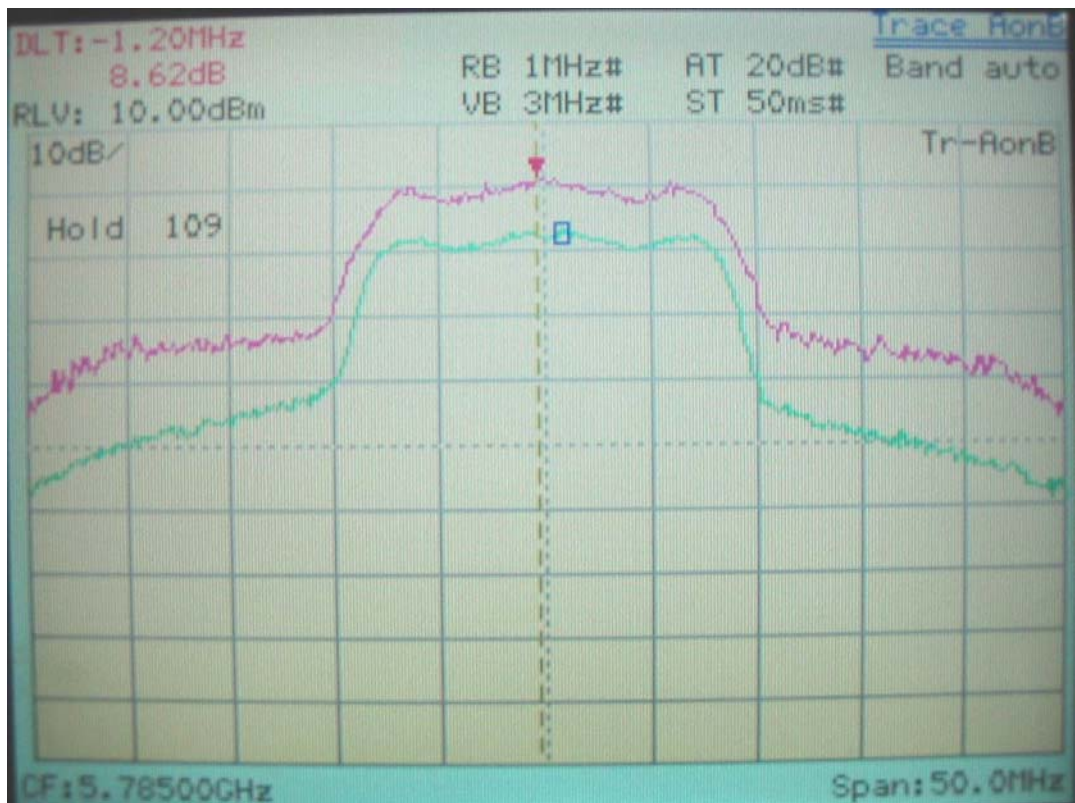

Ant#1

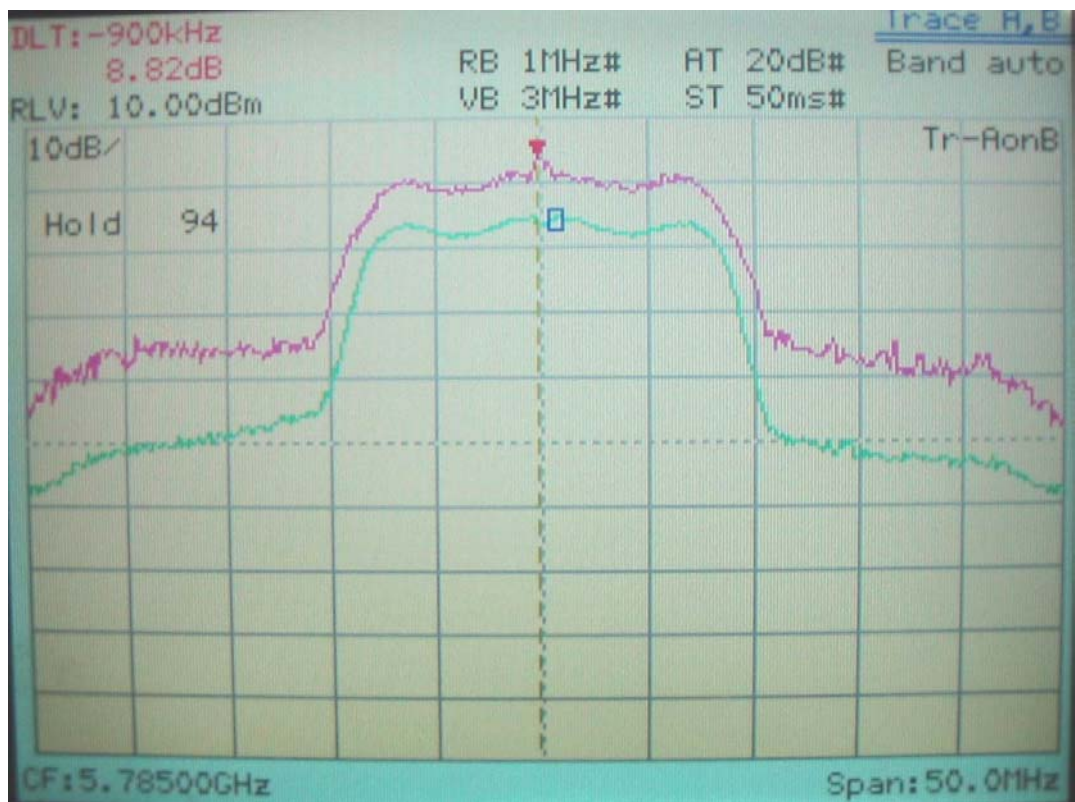

Ant#2

Peak Excursion for IEEE 802.11a, 5805MHz

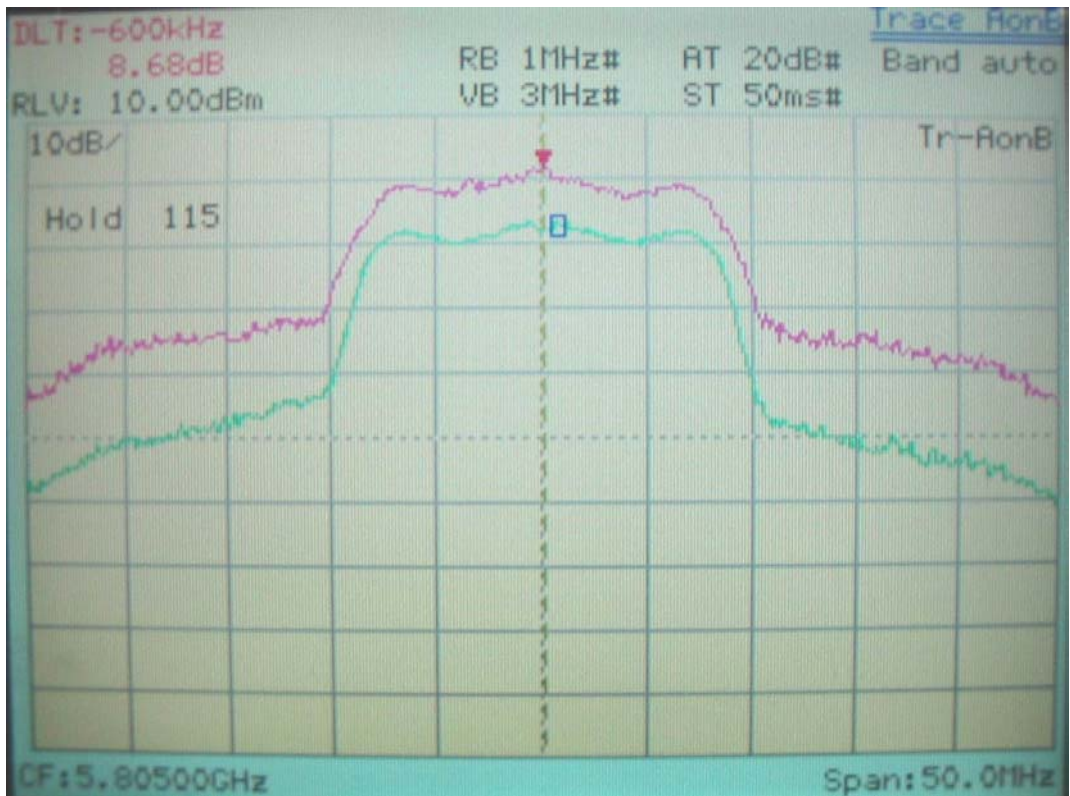

Ant#1

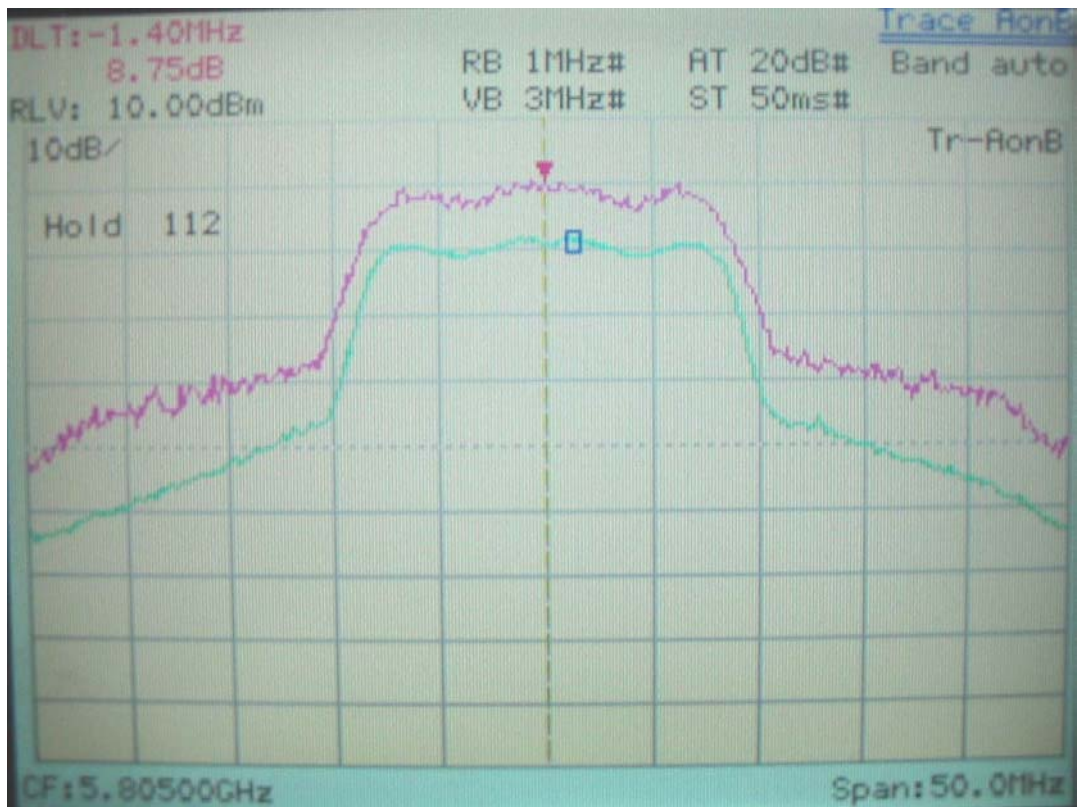

Ant#2

Peak Excursion for IEEE 802.11a 20M, 5745MHz

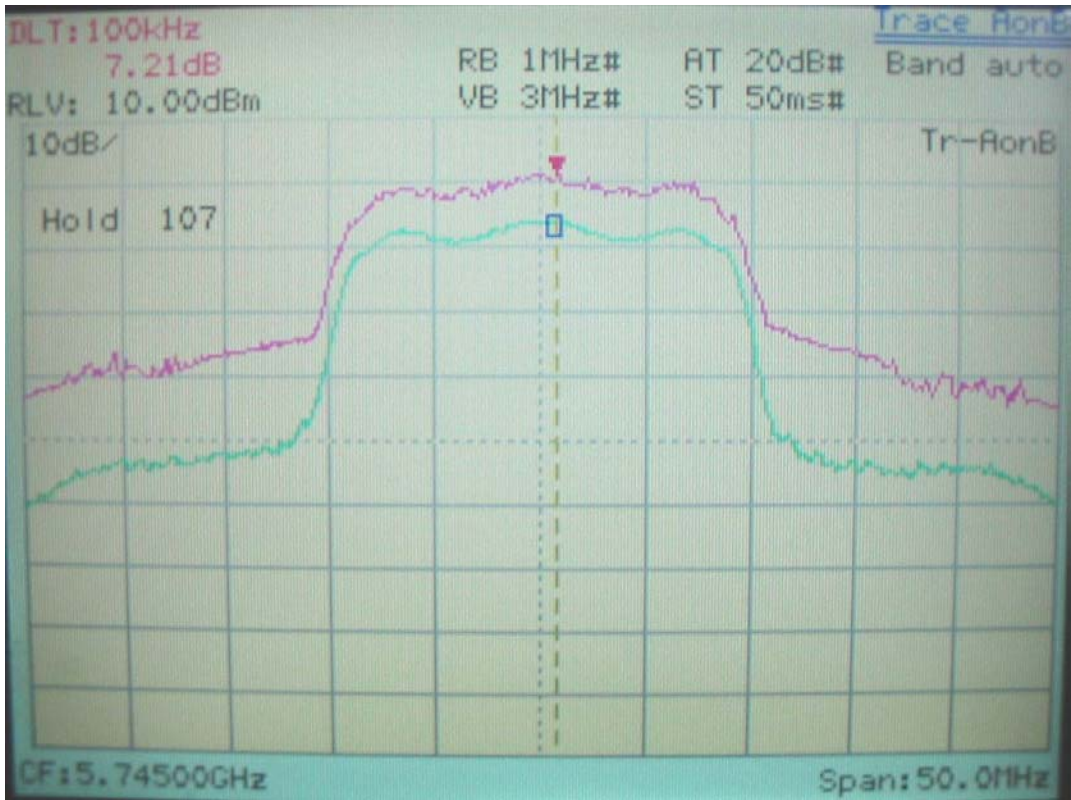

Ant#1

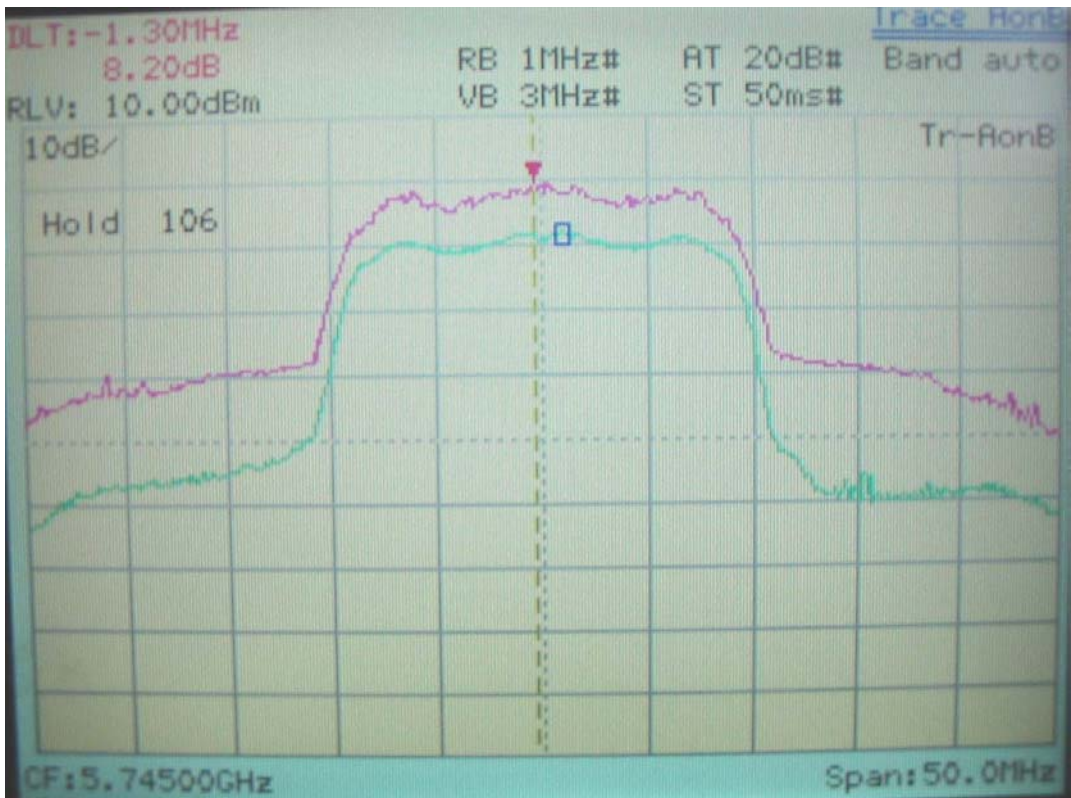

Ant#2

Peak Excursion for IEEE 802.11a 20M, 5785MHz

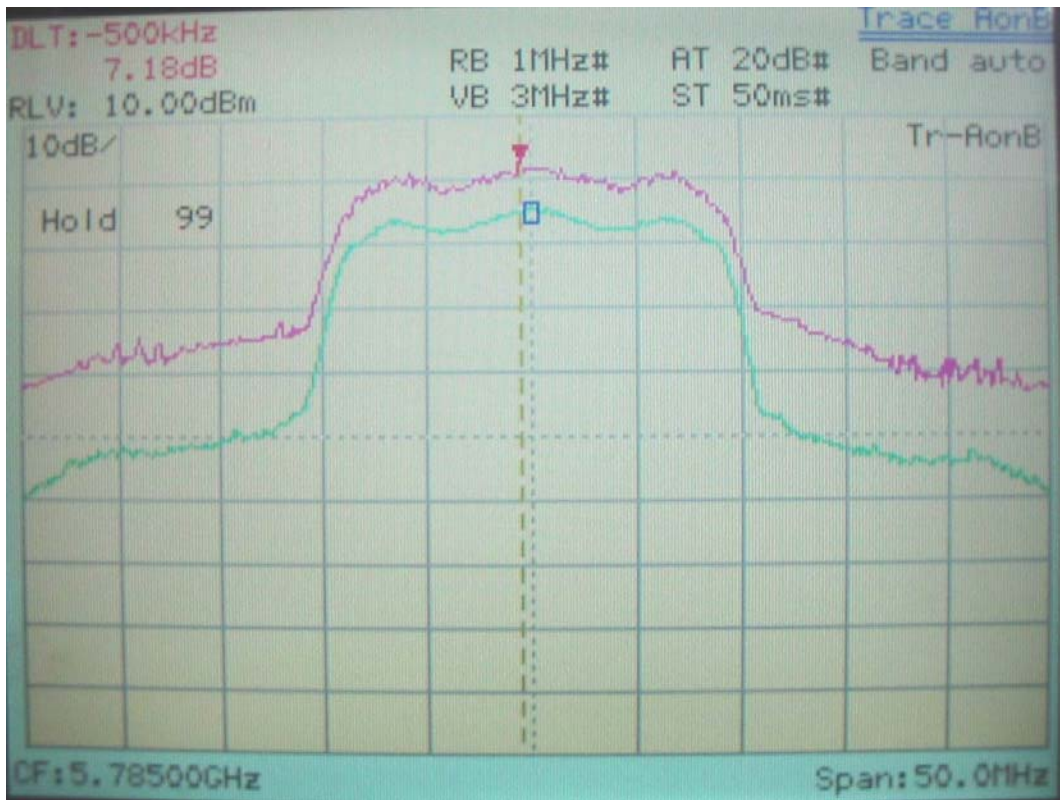

Ant#1

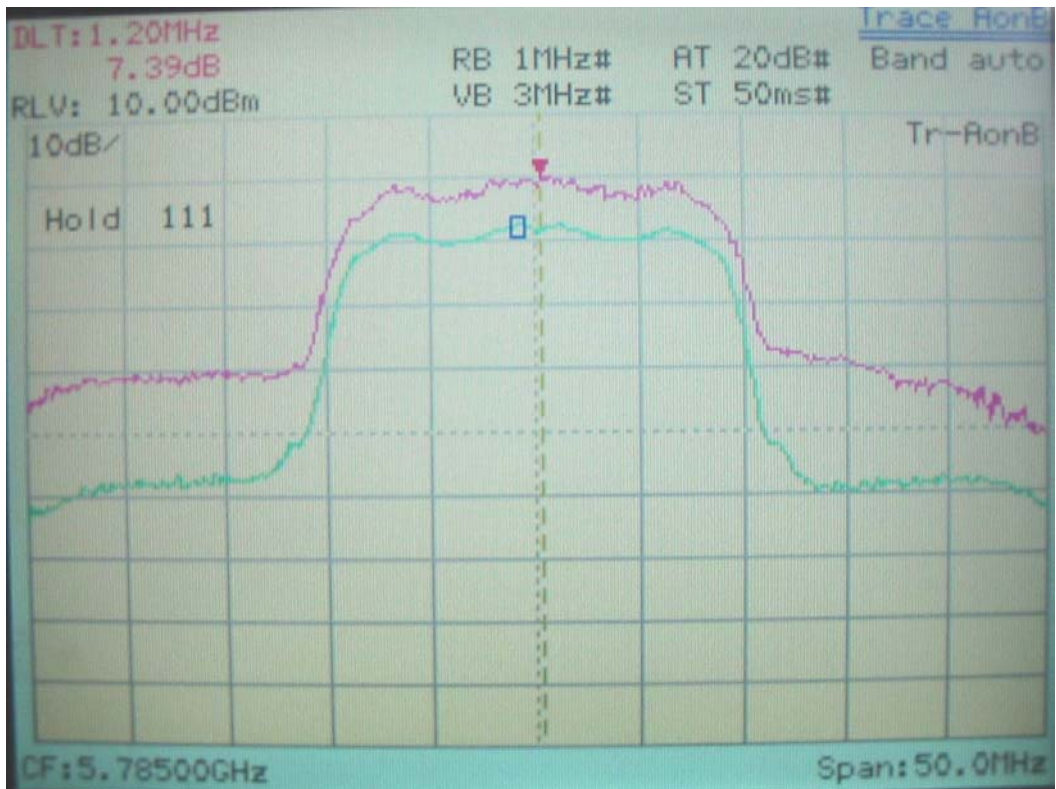

Ant#2

Peak Excursion for IEEE 802.11a 20M, 5805MHz

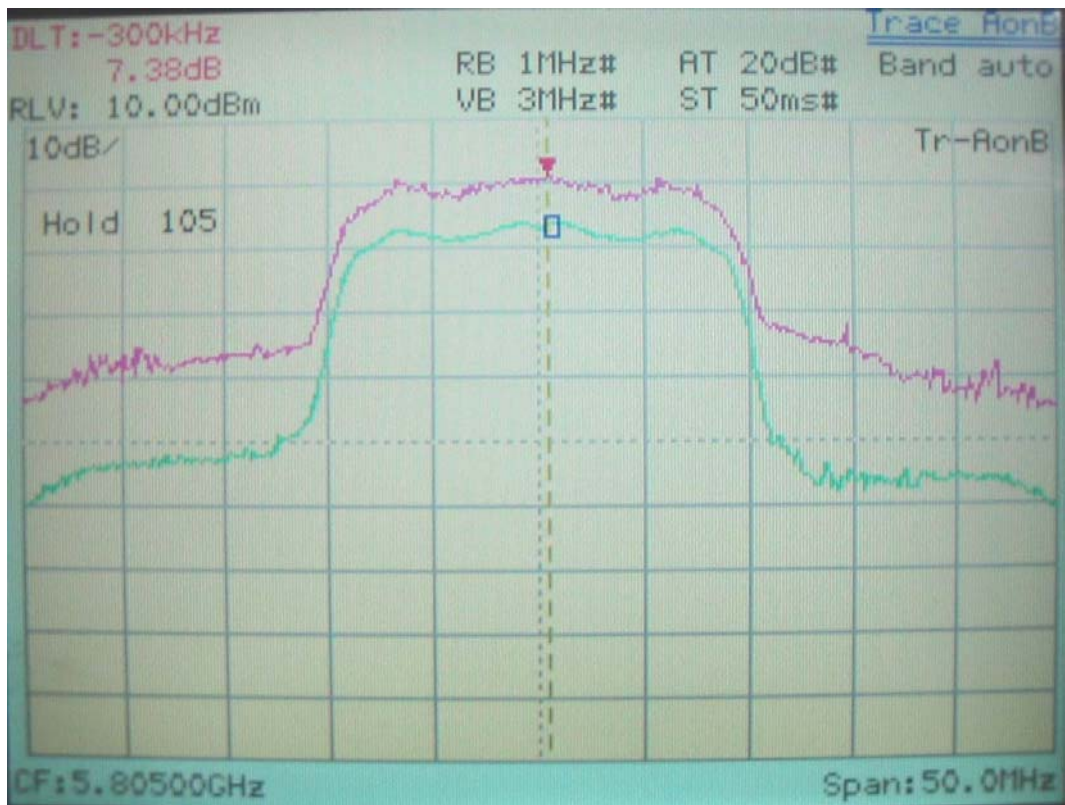

Ant#1



Ant#2

Peak Excursion for IEEE 802.11a 40M, 5755MHz



Ant#1

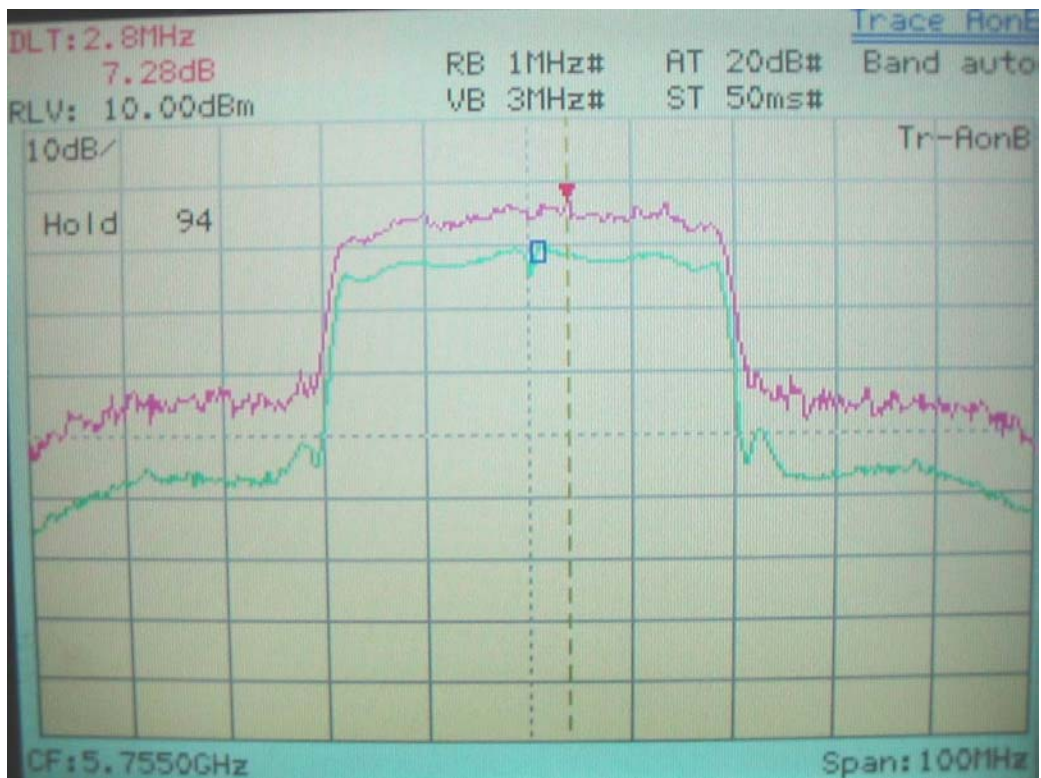

Ant#2

Peak Excursion for IEEE 802.11a 40M, 5795MHz

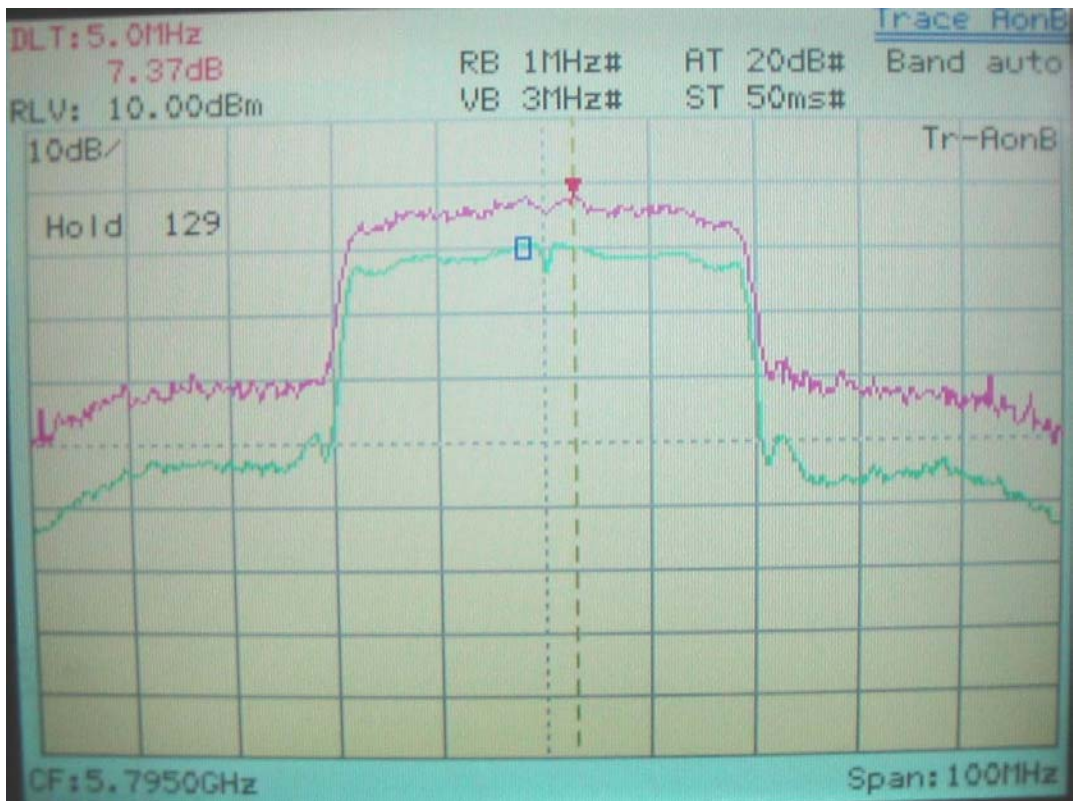

Ant#1



Ant#2

IX. Section 15.407(b)(1), (b)(7): Undesirable Emission and Bandedge

9.1 Undesirable Emission

Limited: For transmitters operating in the 5.15 - 5.25 GHz band – all emissions outside of the 5.15 to 5.35 GHz band shall not exceed an EIRP of -27 dBm / MHz.

For transmitters operating in the 5.725 - 5.825 GHz band – all emissions within the frequency range from the band edge to 10 MHz above or below the band edge shall not exceed an EIRP of -17 dBm / MHz; for frequencies 10 MHz or greater above or below the band edge, emissions shall not exceed and EIRP of -27 dBm.

9.1.1 Test Condition & Setup

The tests below are running with the EUT transmitter set at high power mode. The EUT is needed to force selection of output power level and channel number. While testing, the EUT was set to transmit continuously and to be tested by the contact manner with the spectrum analyzer.

We perform this section by the conducted manner, the RBW is set to RBW= VBW= 1MHz. We'd made the observation up to 40GHz and the criterion is all the harmonic/spurious emissions must be -27dBm/MHz below the highest emission level measured.

9.1.2 Test Instruments Configuration

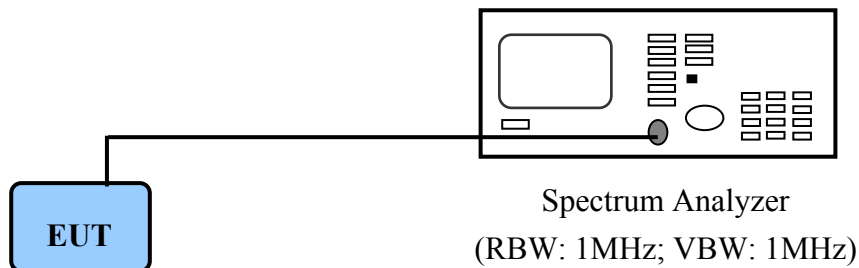

PC to control the EUT at maximal power output and channel number and set antenna kit

9.1.3 List of Test Instruments

Instrument Name	Model No.	Brand	Serial No.	Next time
Spectrum Analyzer	MS2665C	ANRITSU	6200175476	12/19/09

9.1.4 Test Result of Undesirable Emission

IEEE 802.11a

Antenna#1

Frequency (MHz)	Max Read Value (dBm/MHz)	Cable Loss (dB)	Correction Value (dBm/MHz)	Limit (dBm/MHz)	Margin (dB)
5180	-42.67	1.50	-41.17	-27.00	-14.17
5200	-42.00	1.50	-40.50	-27.00	-13.50
5240	-42.33	1.50	-40.83	-27.00	-13.83

Antenna#2

Frequency (MHz)	Max Read Value (dBm/MHz)	Cable Loss (dB)	Correction Value (dBm/MHz)	Limit (dBm/MHz)	Margin (dB)
5180	-42.83	1.50	-41.33	-27.00	-14.33
5200	-42.50	1.50	-41.00	-27.00	-14.00
5240	-42.67	1.50	-41.17	-27.00	-14.17

Note:

1. The following pages show the results of spectrum reading.
2. Correction Value: spectrum read power density (using peak search mode),
Correction Value: actual peak power density in the spread spectrum band.
3. Correction Value = Max Read Value + Cable Loss

IEEE 802.11a 20M

Antenna#1

Frequency (MHz)	Max Read Value (dBm/MHz)	Cable Loss (dB)	Correction Value (dBm/MHz)	Limit (dBm/MHz)	Margin (dB)
5180	-42.17	1.50	-40.67	-27.00	-13.67
5200	-41.83	1.50	-40.33	-27.00	-13.33
5240	-42.33	1.50	-40.83	-27.00	-13.83

Antenna#2

Frequency (MHz)	Max Read Value (dBm/MHz)	Cable Loss (dB)	Correction Value (dBm/MHz)	Limit (dBm/MHz)	Margin (dB)
5180	-42.17	1.50	-40.67	-27.00	-13.67
5200	-41.83	1.50	-40.33	-27.00	-13.33
5240	-42.67	1.50	-41.17	-27.00	-14.17

IEEE 802.11a 40M

Antenna#1

Frequency (MHz)	Max Read Value (dBm/MHz)	Cable Loss (dB)	Correction Value (dBm/MHz)	Limit (dBm/MHz)	Margin (dB)
5190	-42.33	1.50	-40.83	-27.00	-13.83
5230	-42.83	1.50	-41.33	-27.00	-14.33

Antenna#2

Frequency (MHz)	Max Read Value (dBm/MHz)	Cable Loss (dB)	Correction Value (dBm/MHz)	Limit (dBm/MHz)	Margin (dB)
5190	-42.50	1.50	-41.00	-27.00	-14.00
5230	-42.17	1.50	-40.67	-27.00	-13.67

IEEE 802.11a

Antenna#1

Frequency (MHz)	Max Read Value (dBm/MHz)	Cable Loss (dB)	Correction Value (dBm/MHz)	Limit (dBm/MHz)	Margin (dB)
5745	-41.83	1.50	-40.33	-27.00	-13.33
5785	-42.67	1.50	-41.17	-27.00	-14.17
5805	-42.67	1.50	-41.17	-27.00	-14.17

Antenna#2

Frequency (MHz)	Max Read Value (dBm/MHz)	Cable Loss (dB)	Correction Value (dBm/MHz)	Limit (dBm/MHz)	Margin (dB)
5745	-42.50	1.50	-41.00	-27.00	-14.00
5785	-42.17	1.50	-40.67	-27.00	-13.67
5805	-42.50	1.50	-41.00	-27.00	-14.00

IEEE 802.11a 20M

Antenna#1

Frequency (MHz)	Max Read Value (dBm/MHz)	Cable Loss (dB)	Correction Value (dBm/MHz)	Limit (dBm/MHz)	Margin (dB)
5745	-42.00	1.50	-40.50	-27.00	-13.50
5785	-42.67	1.50	-41.17	-27.00	-14.17
5805	-41.67	1.50	-40.17	-27.00	-13.17

Antenna#2

Frequency (MHz)	Max Read Value (dBm/MHz)	Cable Loss (dB)	Correction Value (dBm/MHz)	Limit (dBm/MHz)	Margin (dB)
5745	-42.17	1.50	-40.67	-27.00	-13.67
5785	-42.17	1.50	-40.67	-27.00	-13.67
5805	-42.50	1.50	-41.00	-27.00	-14.00

IEEE 802.11a 40M

Antenna#1

Frequency (MHz)	Max Read Value (dBm/MHz)	Cable Loss (dB)	Correction Value (dBm/MHz)	Limit (dBm/MHz)	Margin (dB)
5755	-42.33	1.50	-40.83	-27.00	-13.83
5795	-42.83	1.50	-41.33	-27.00	-14.33

Antenna#2

Frequency (MHz)	Max Read Value (dBm/MHz)	Cable Loss (dB)	Correction Value (dBm/MHz)	Limit (dBm/MHz)	Margin (dB)
5755	-42.33	1.50	-40.83	-27.00	-13.83
5795	-41.00	1.50	-39.50	-27.00	-12.50

IEEE 802.11a, 5180MHz (Antenna#1)
30MHz-1GHz

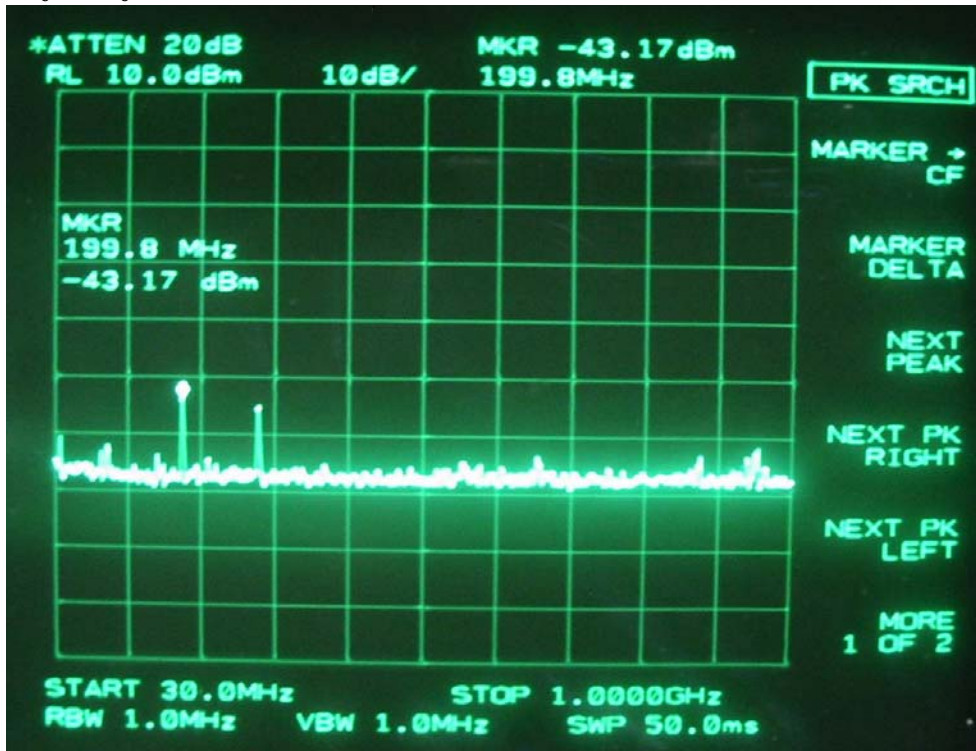

1GHz-10GHz

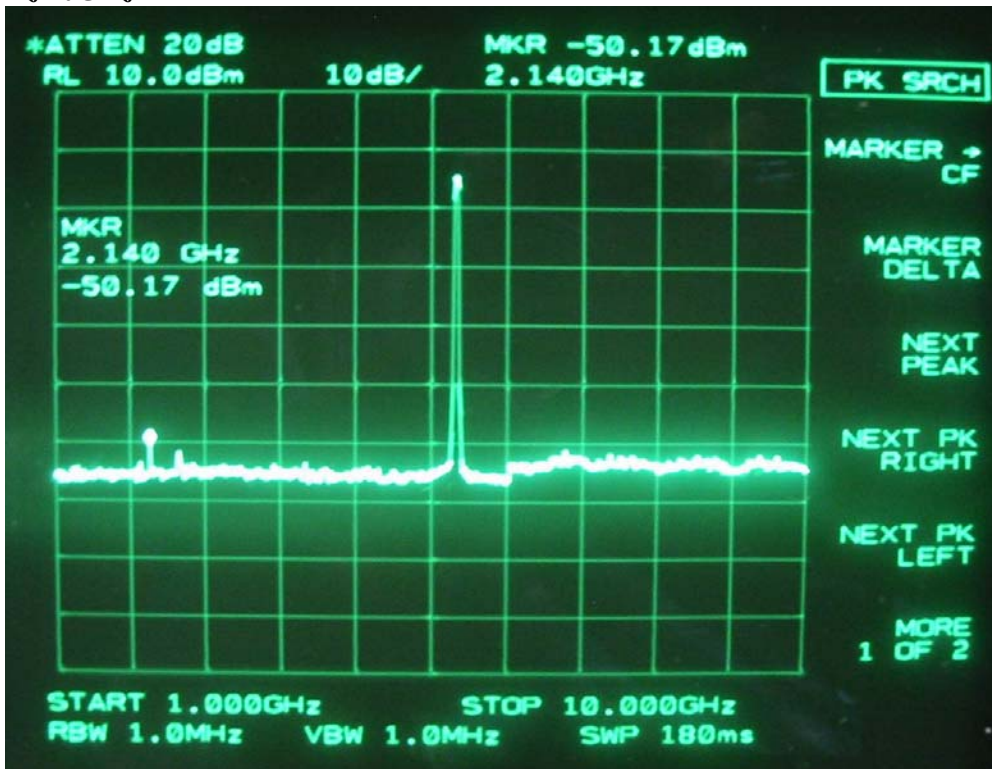

10GHz-25GHz

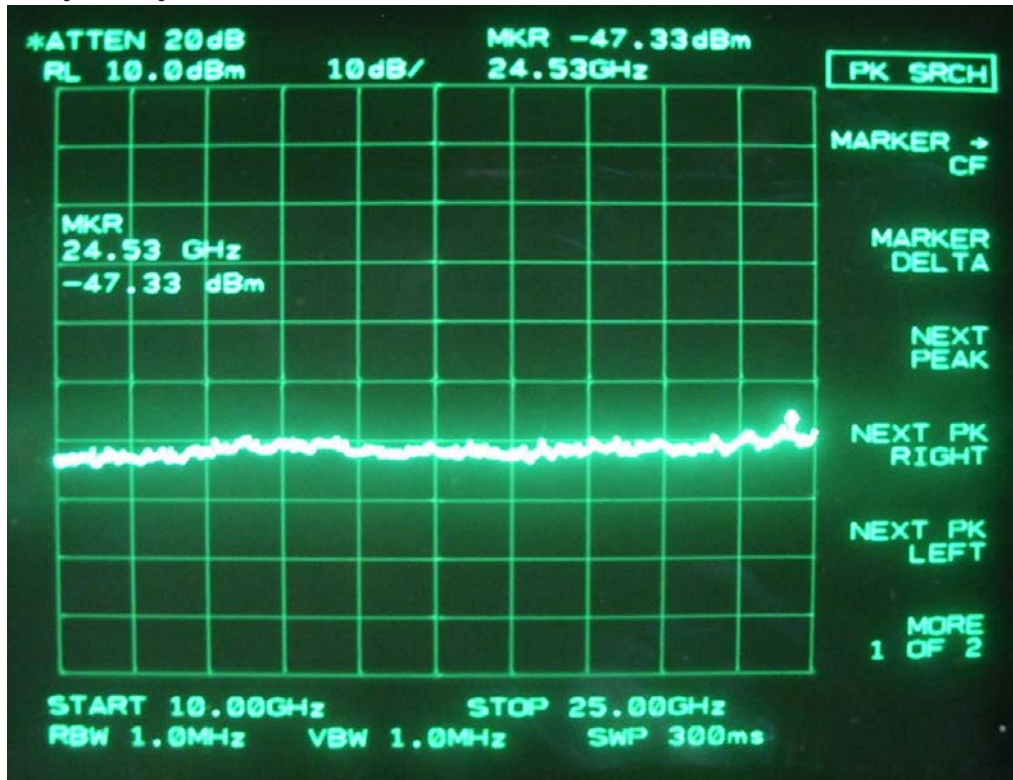

25GHz-40GHz

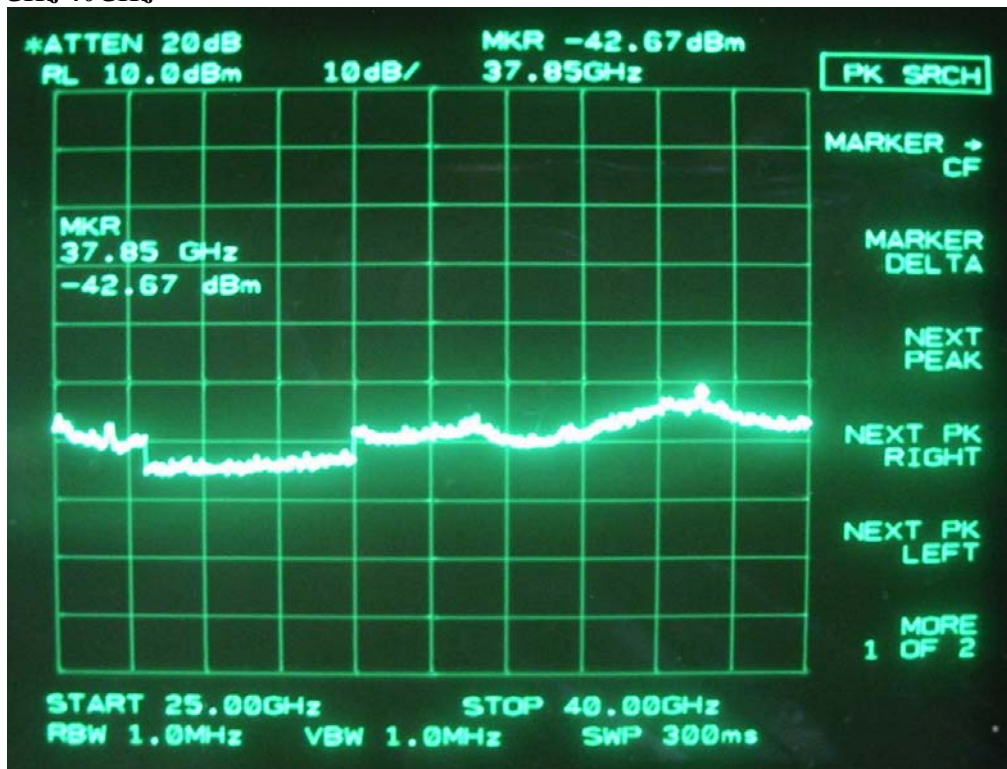

IEEE 802.11a, 5180MHz (Antenna#2)

30MHz-1GHz

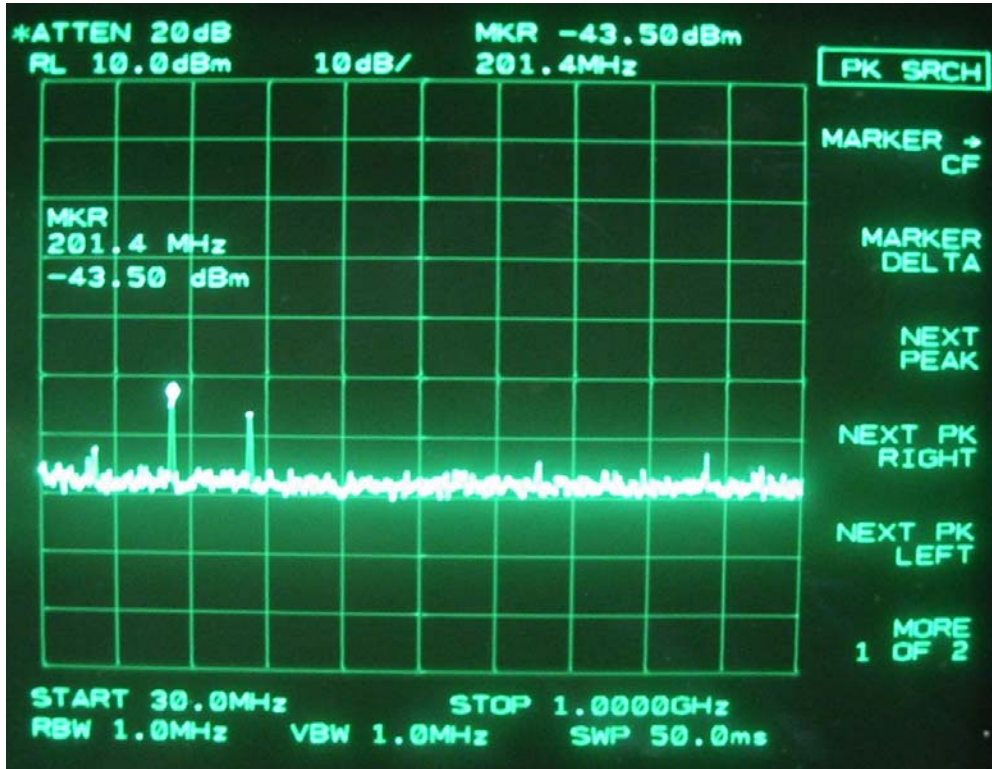

1GHz-10GHz

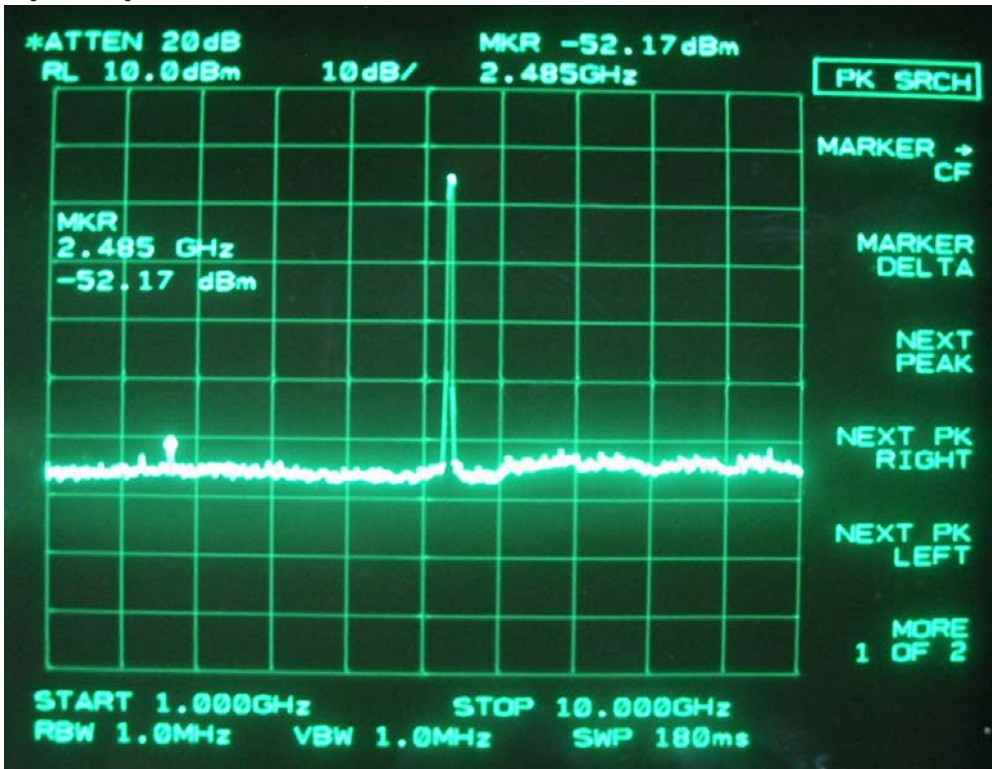

10GHz-25GHz

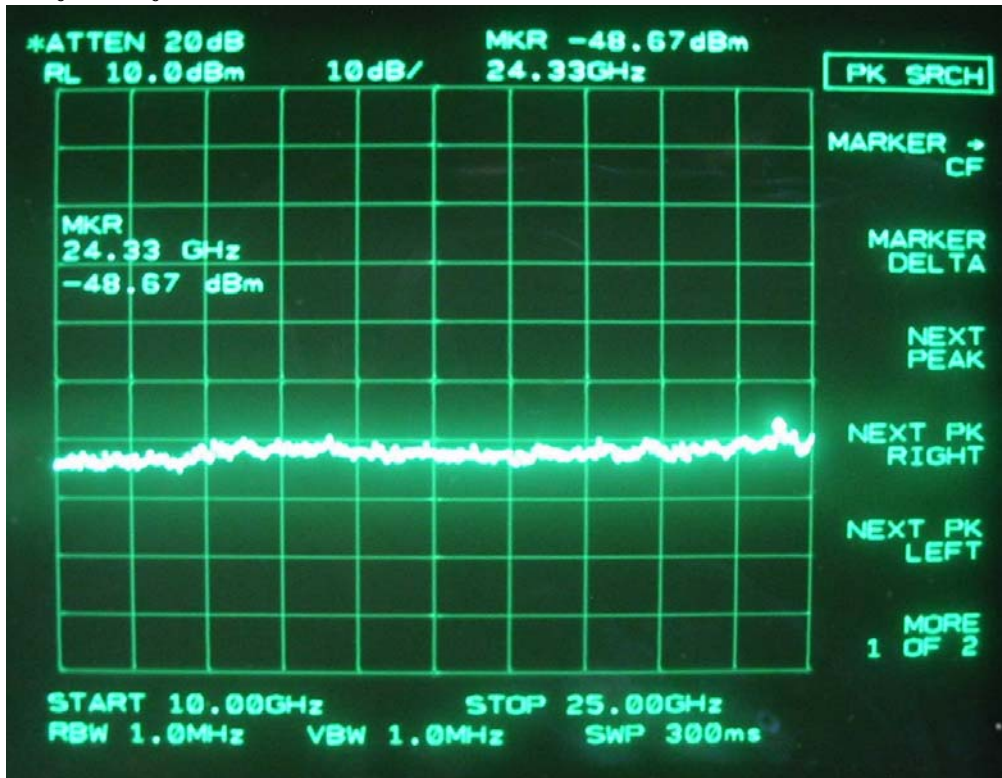

25GHz-40GHz

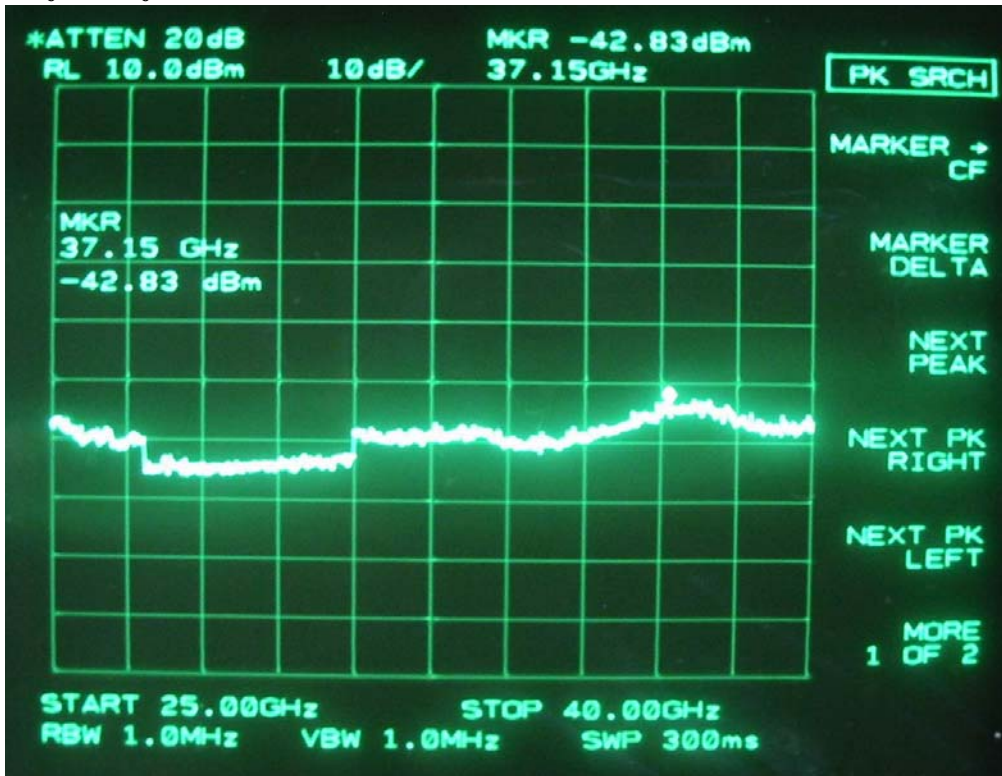

IEEE 802.11a, 5200MHz (Antenna#1)

30MHz-1GHz

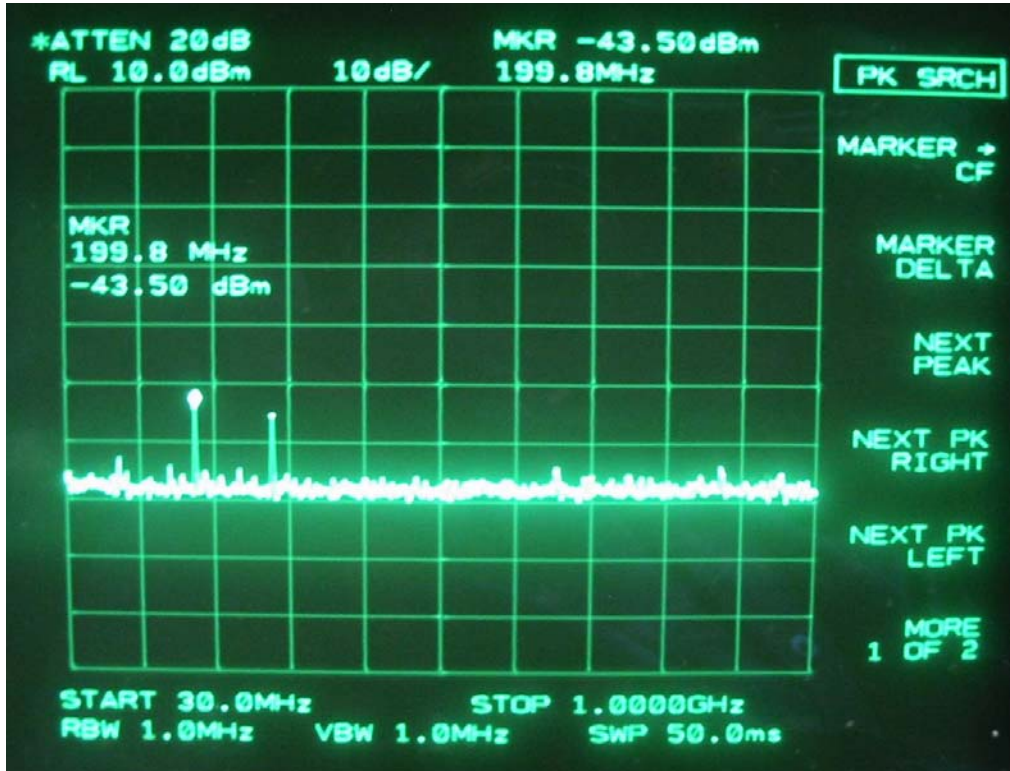

1GHz-10GHz

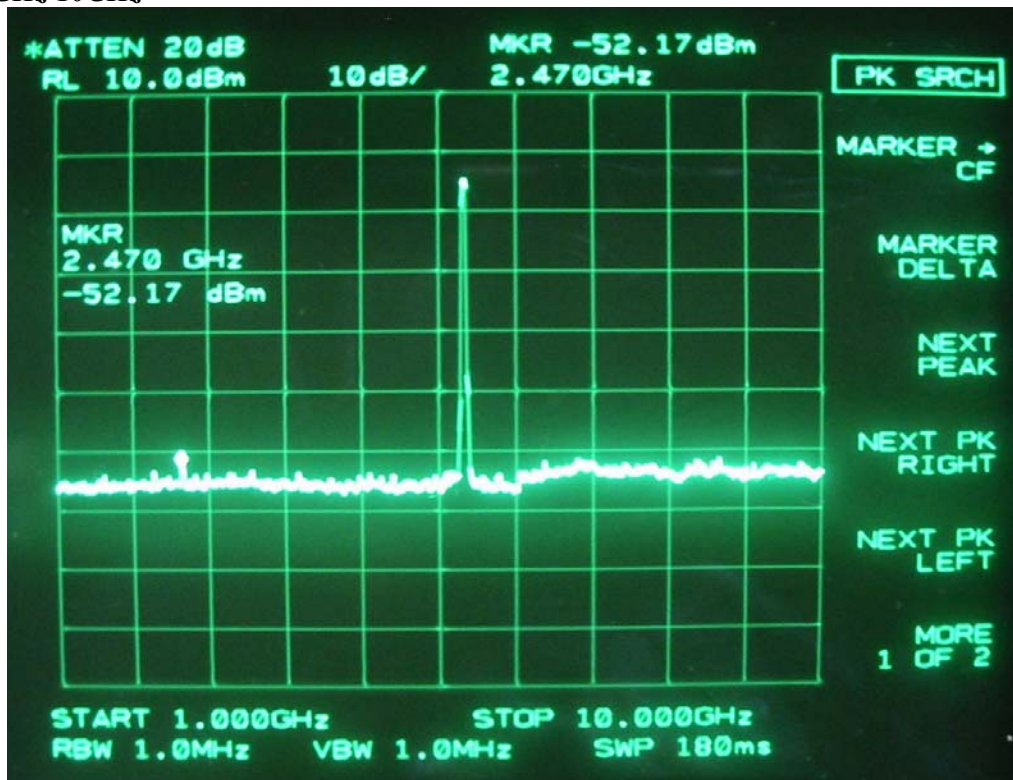

10GHz-25GHz

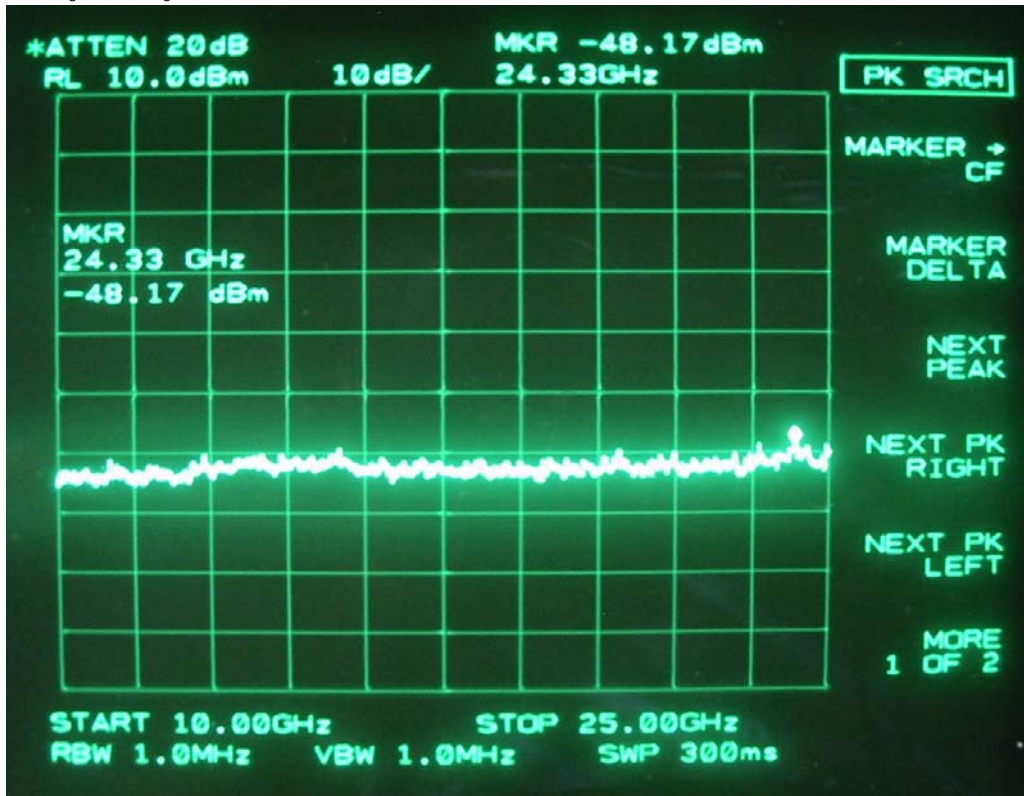

25GHz-40GHz

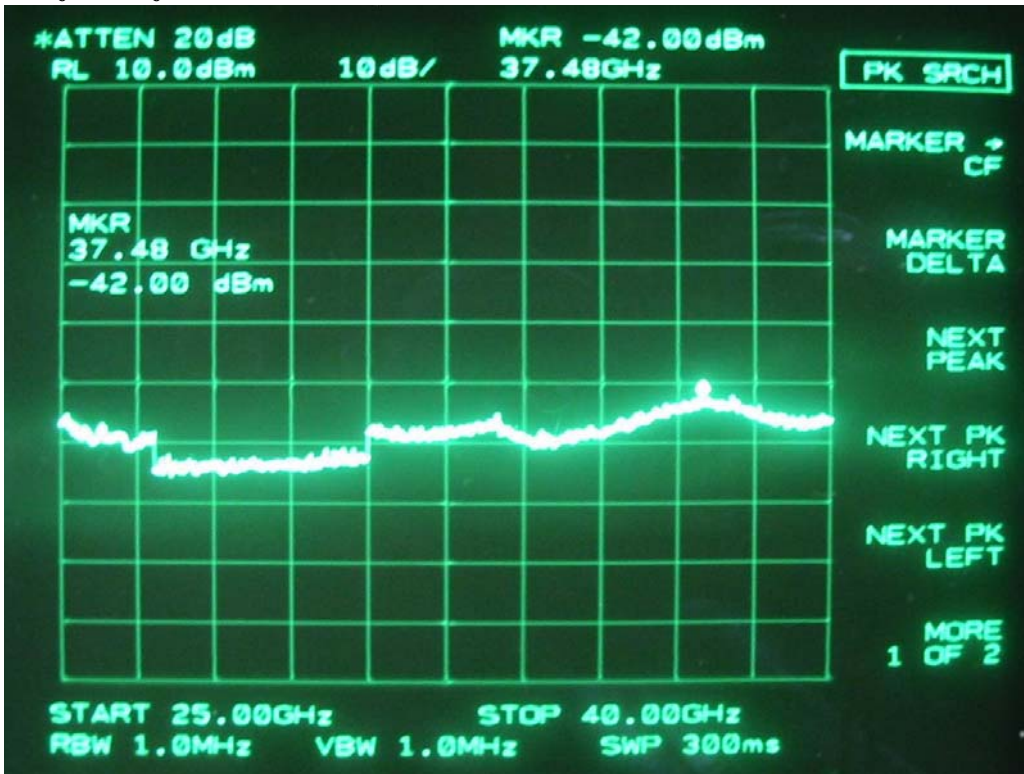

IEEE 802.11a, 5200MHz (Antenna#2)

30MHz-1GHz

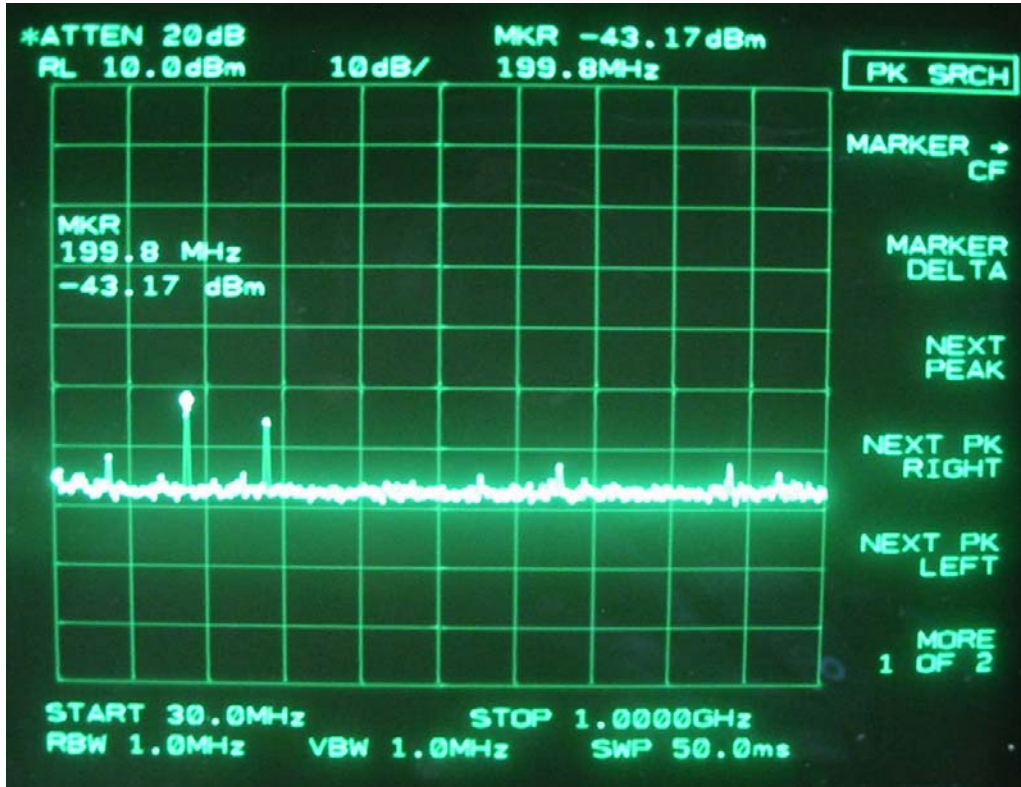

1GHz-10GHz

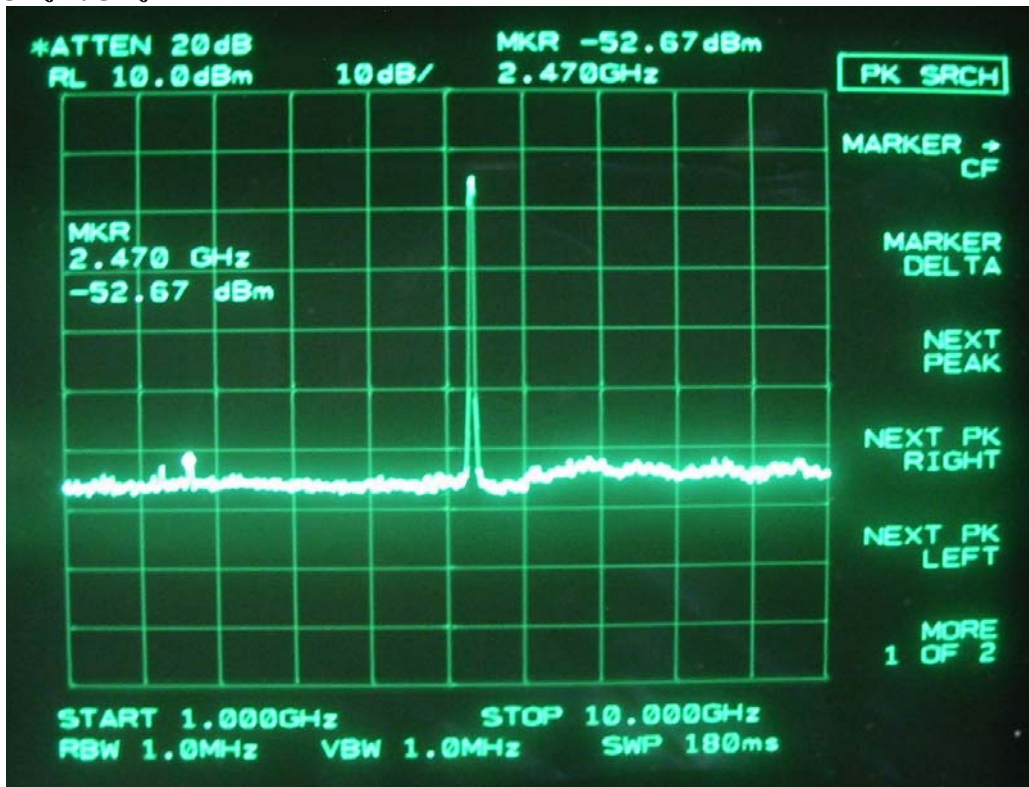

10GHz-25GHz

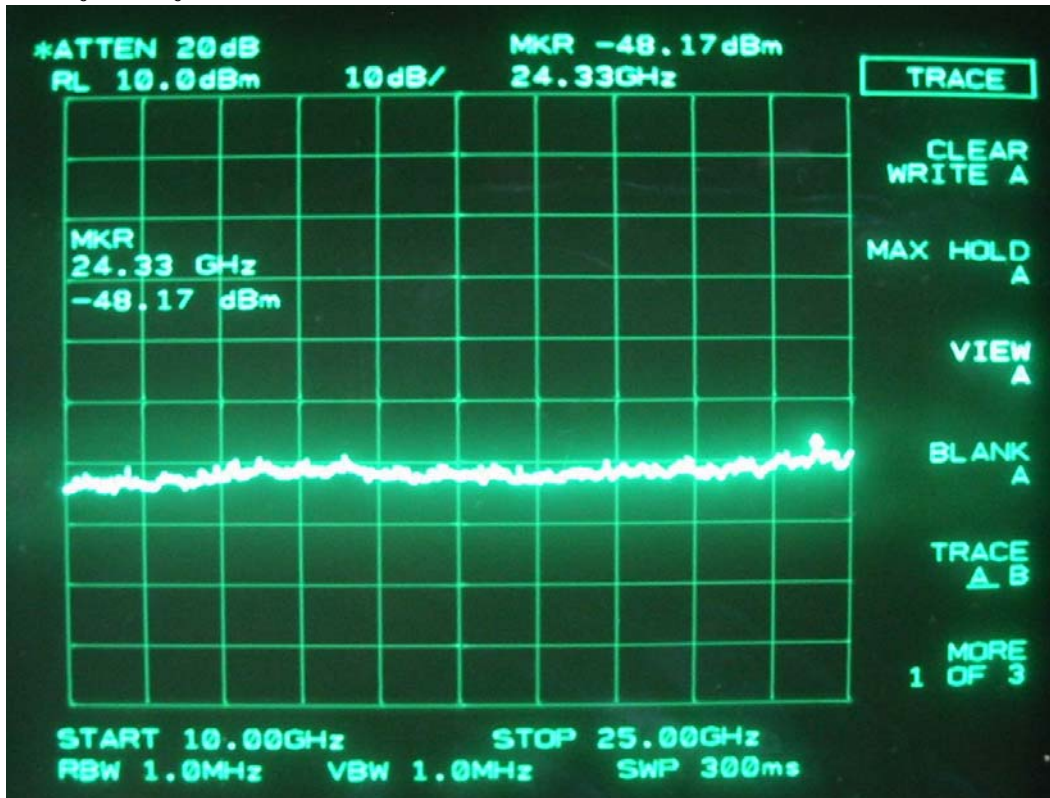

25GHz-40GHz

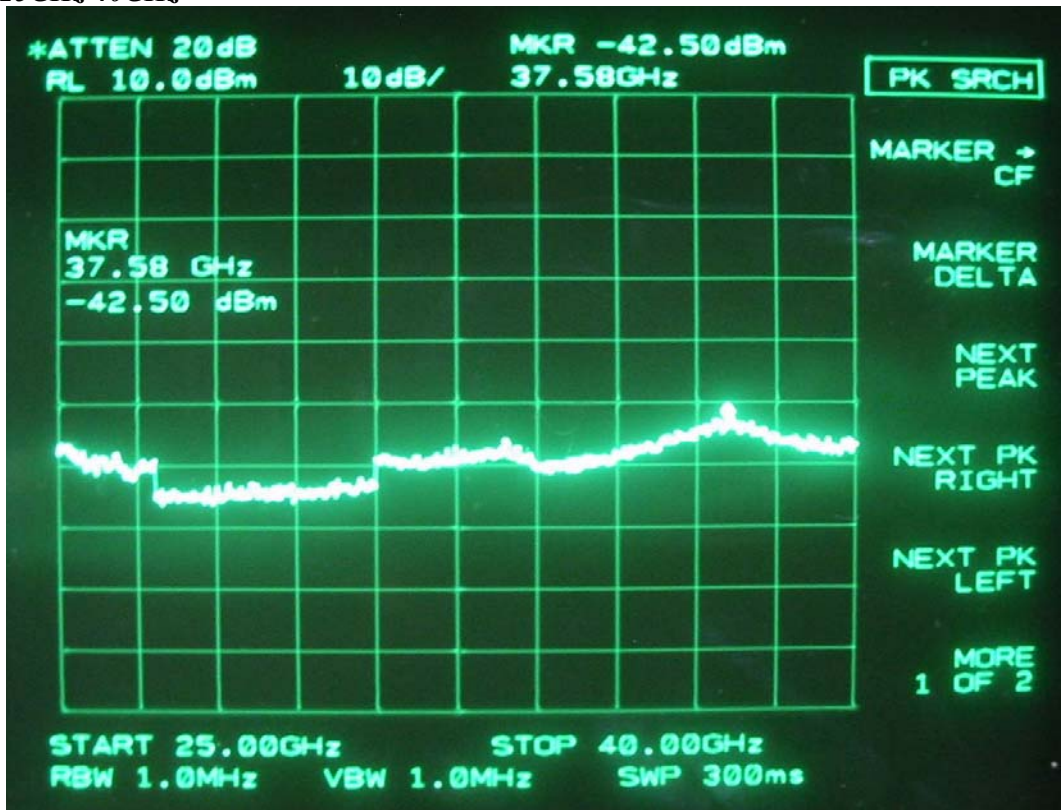

IEEE 802.11a, 5240MHz (Antenna#1)

30MHz-1GHz

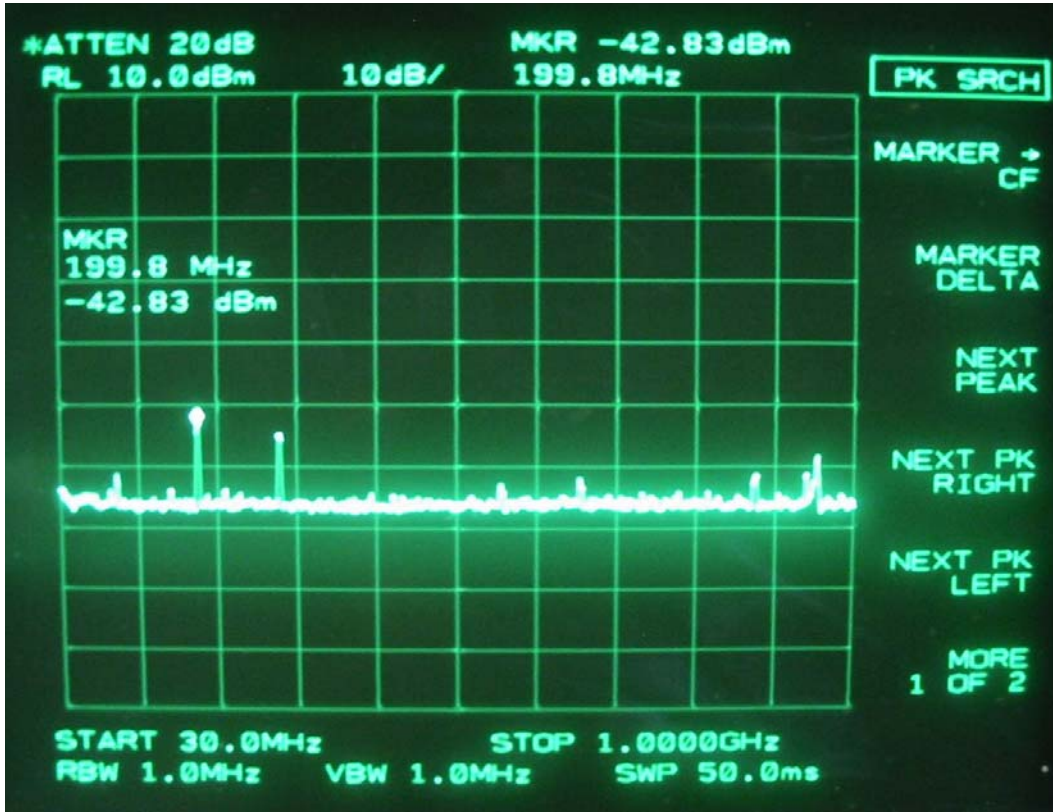

1GHz-10GHz

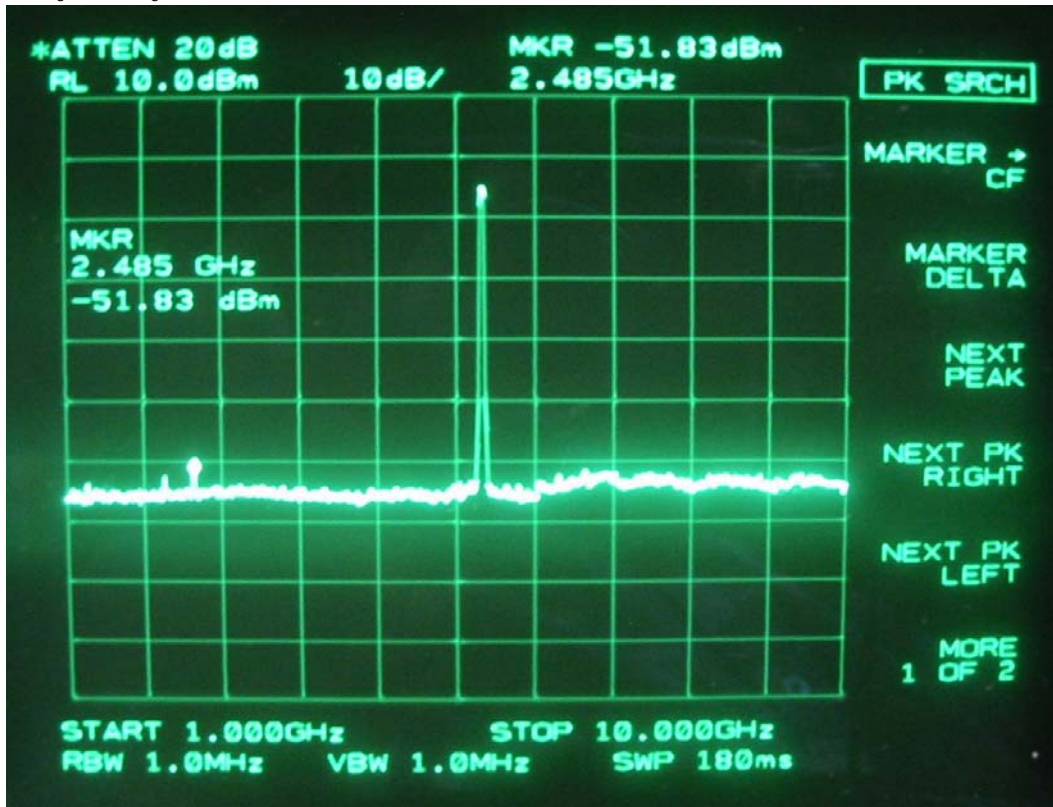

10GHz-25GHz

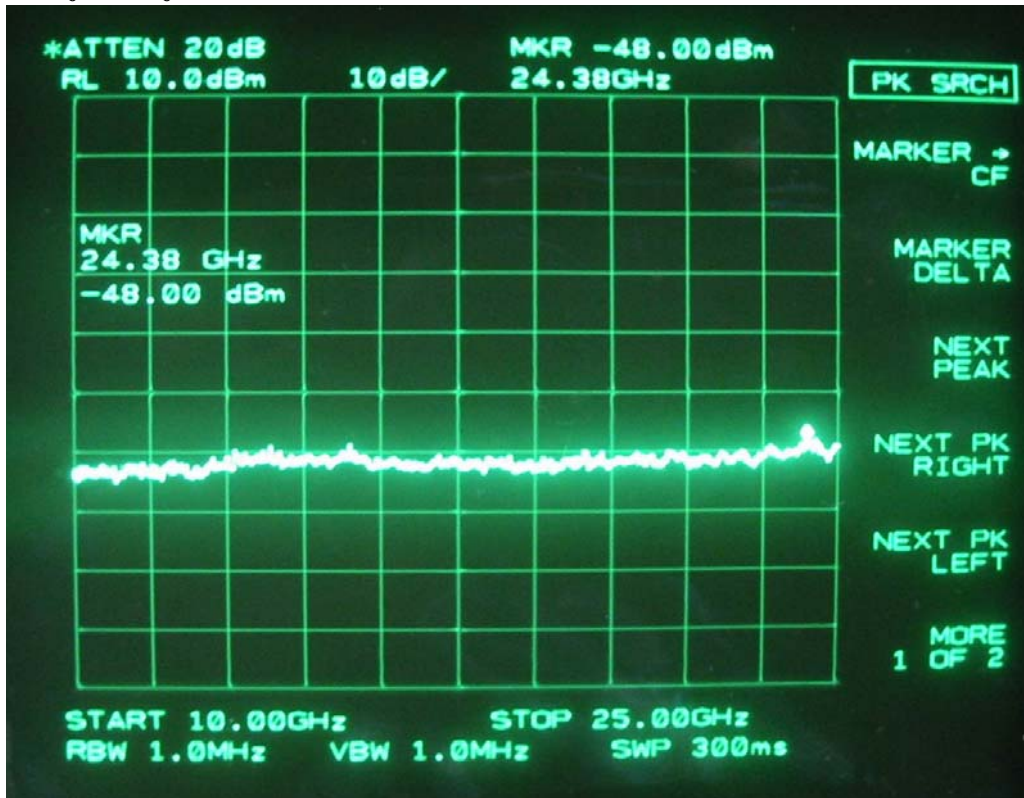

25GHz-40GHz

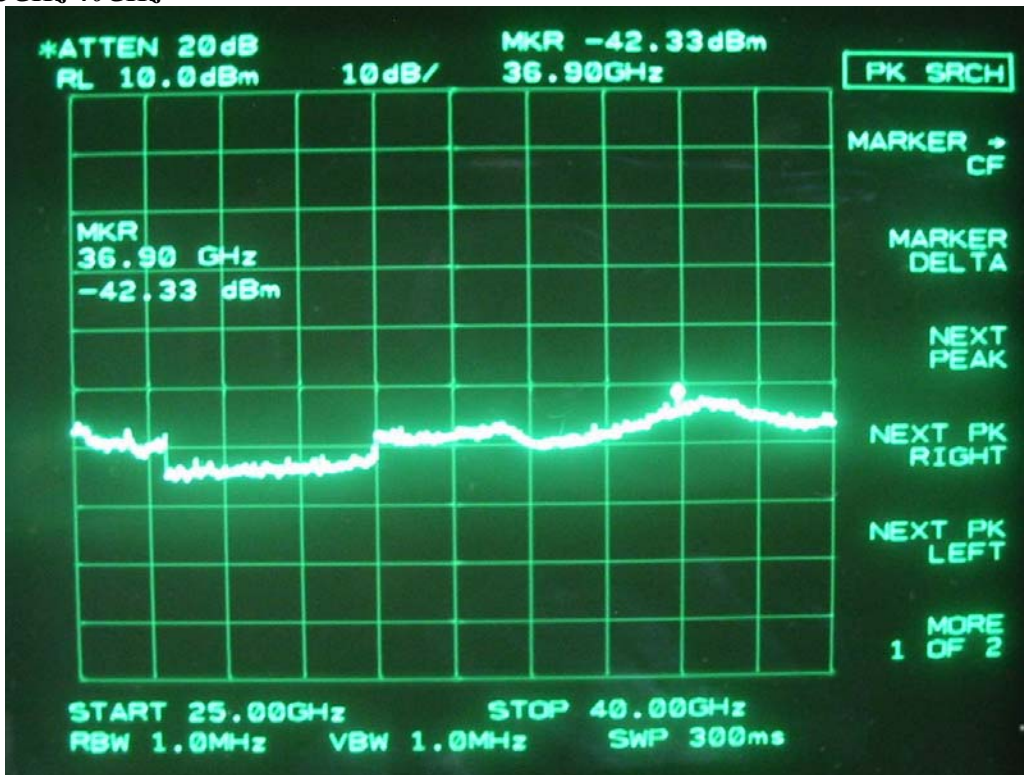

IEEE 802.11a, 5240MHz (Antenna#2)

30MHz-1GHz

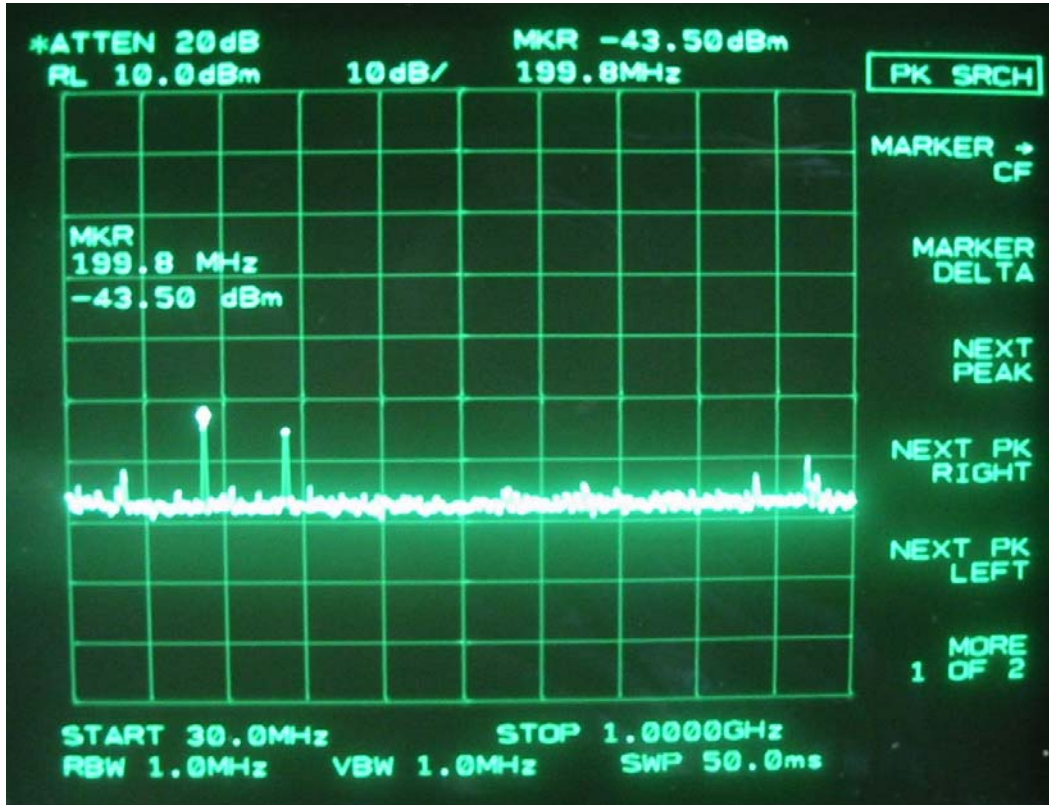

1GHz-10GHz

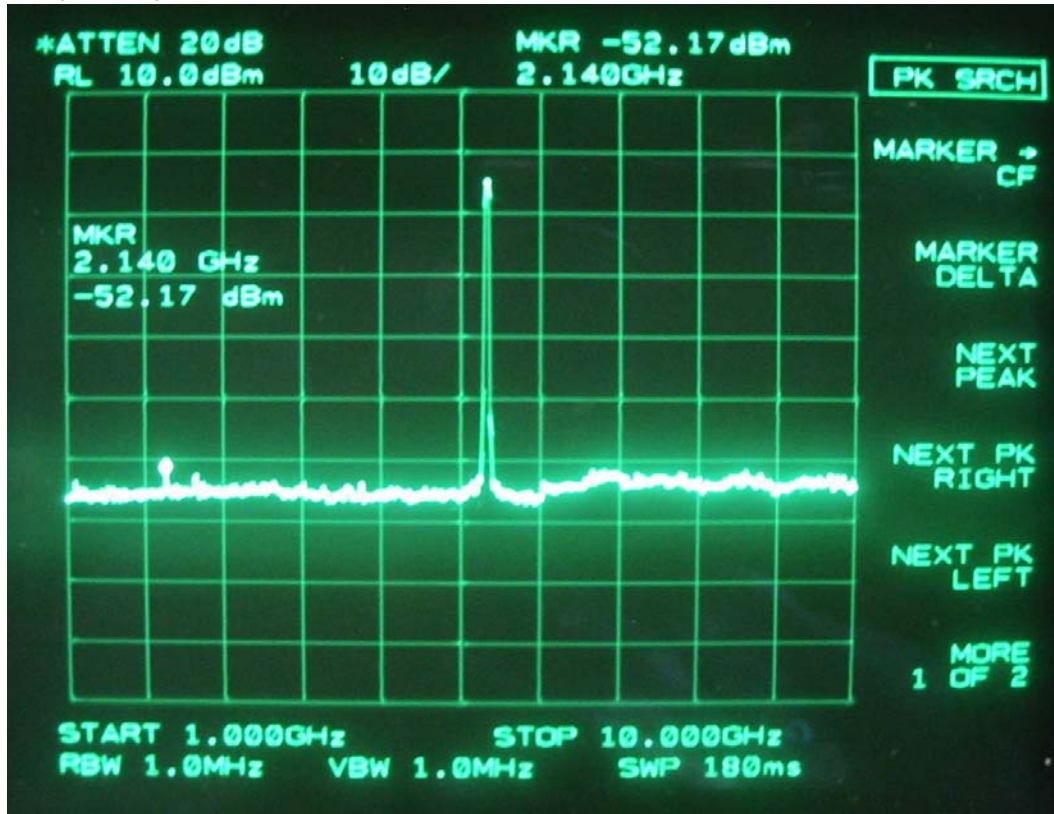

10GHz-25GHz

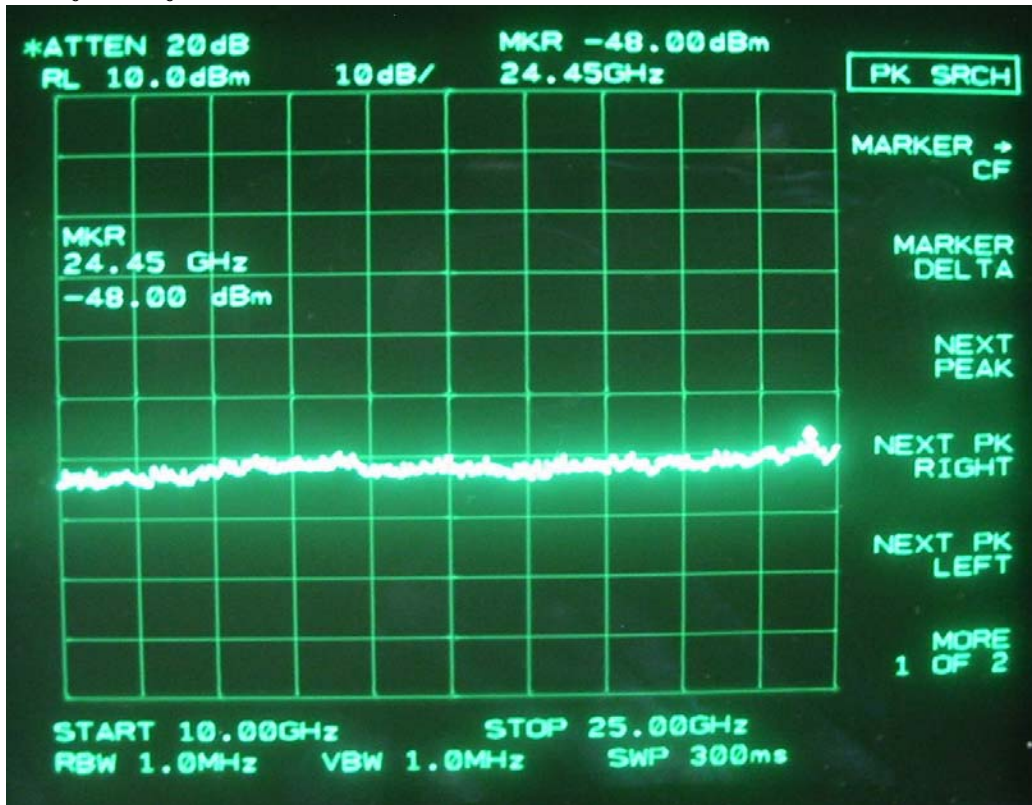

25GHz-40GHz

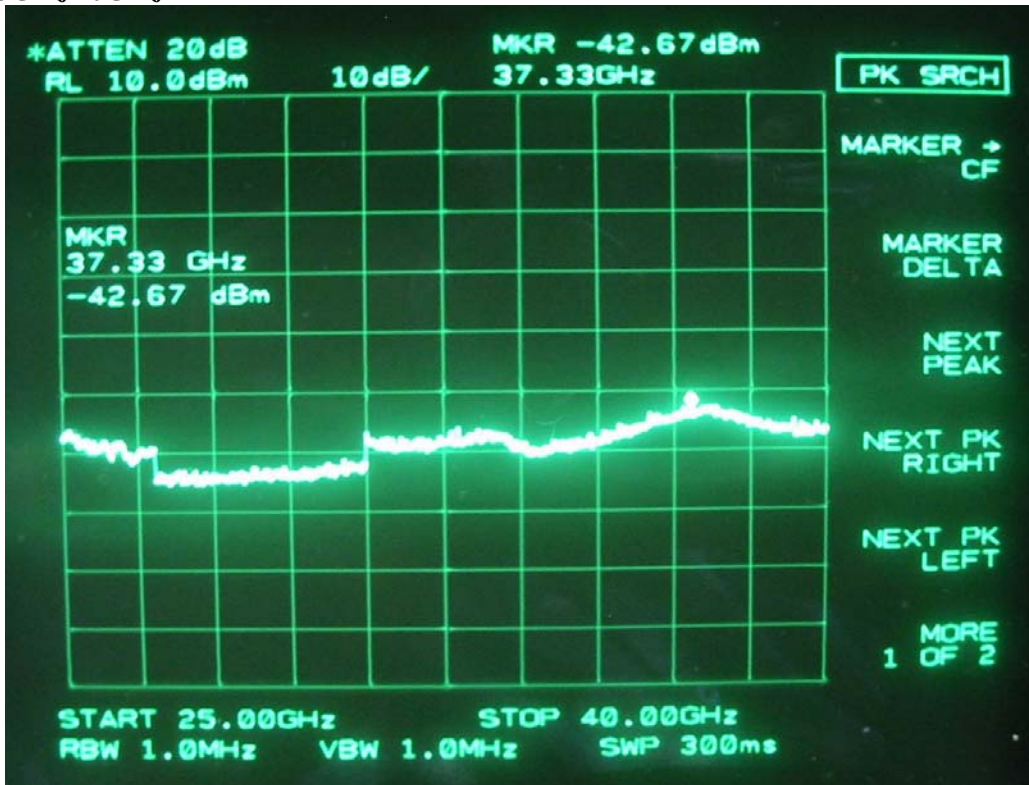

IEEE 802.11a 20M, 5180MHz (Antenna#1)
30MHz-1GHz

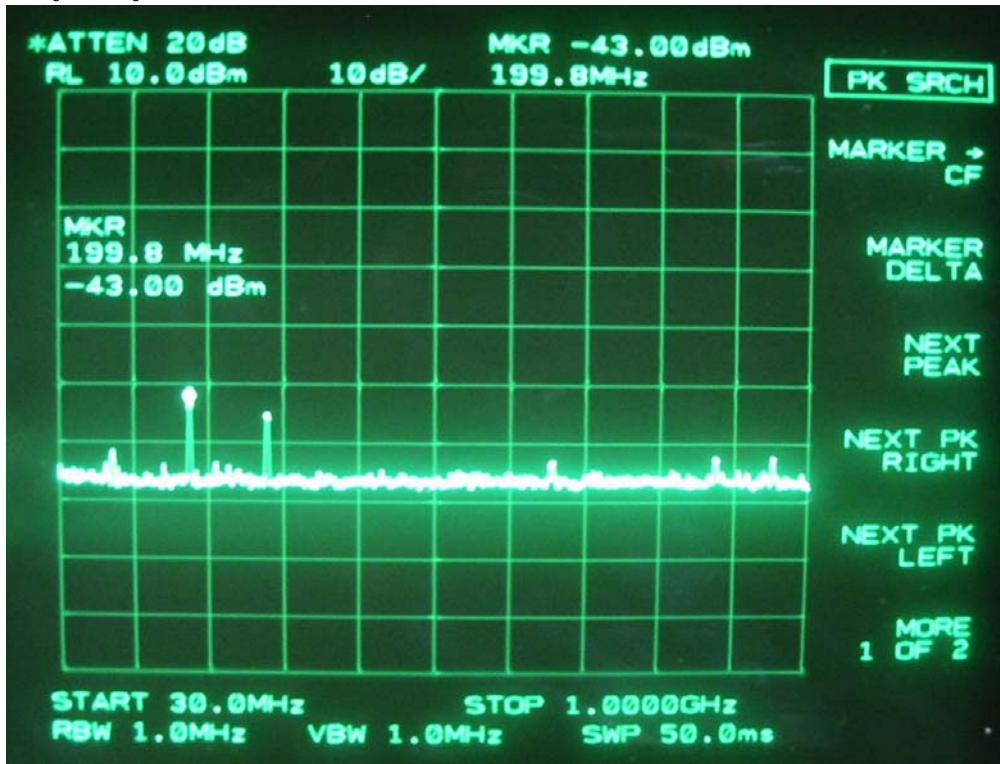

1GHz-10GHz

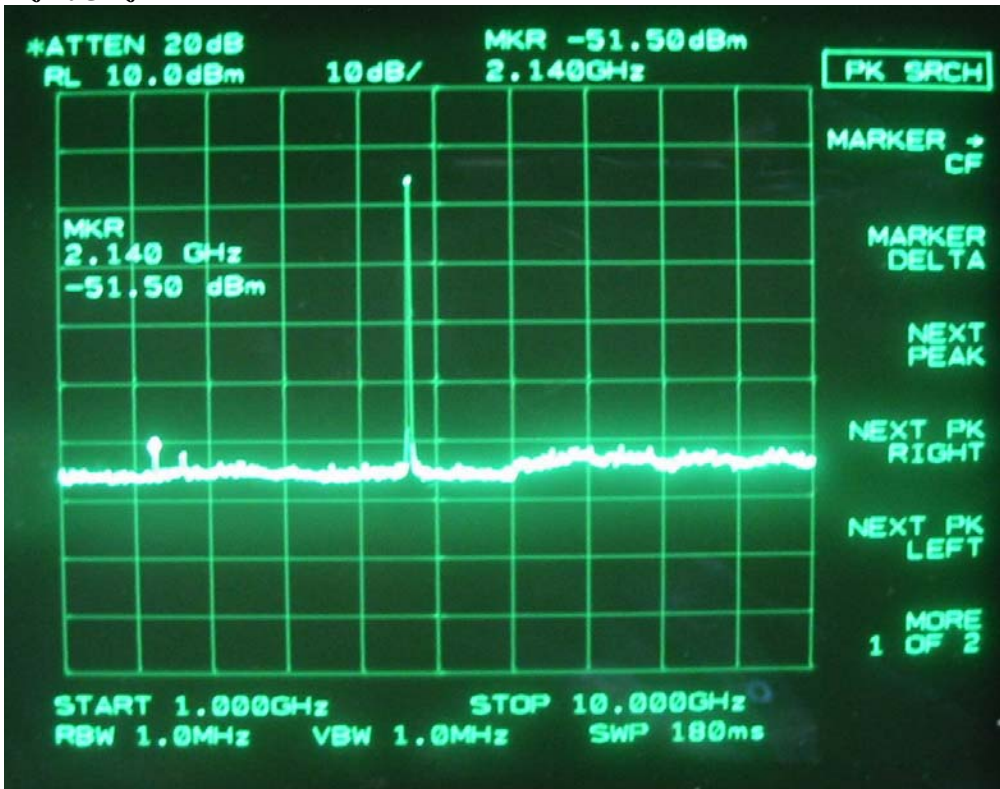

10GHz-25GHz

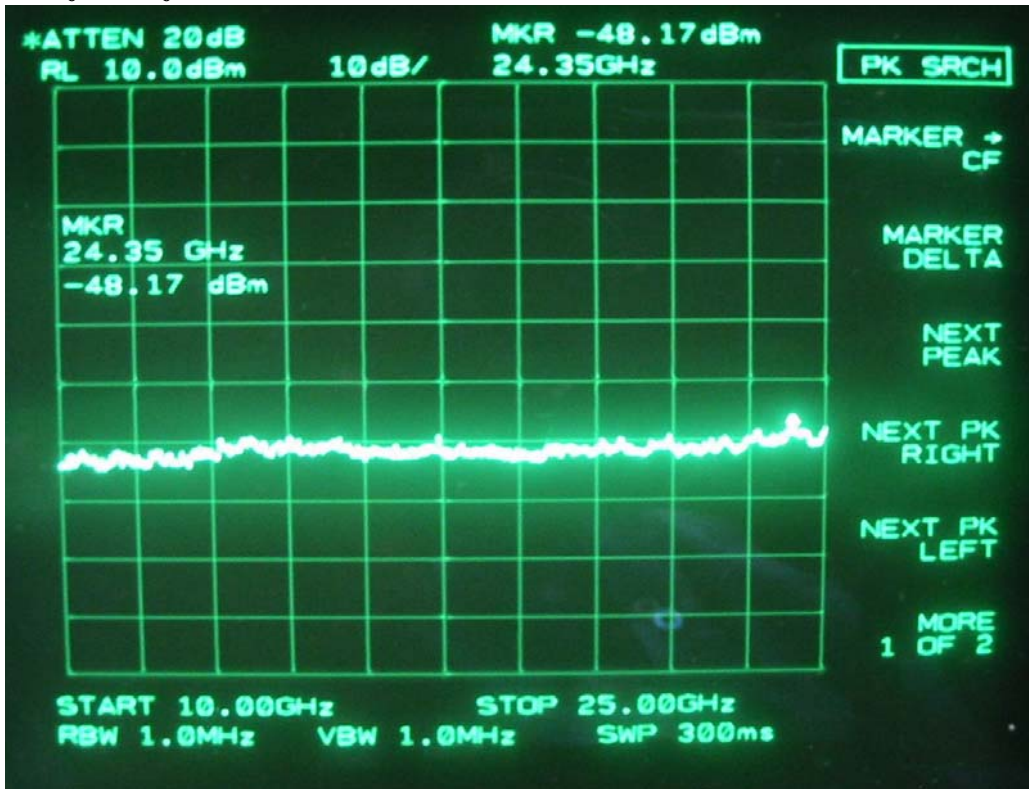

25GHz-40GHz

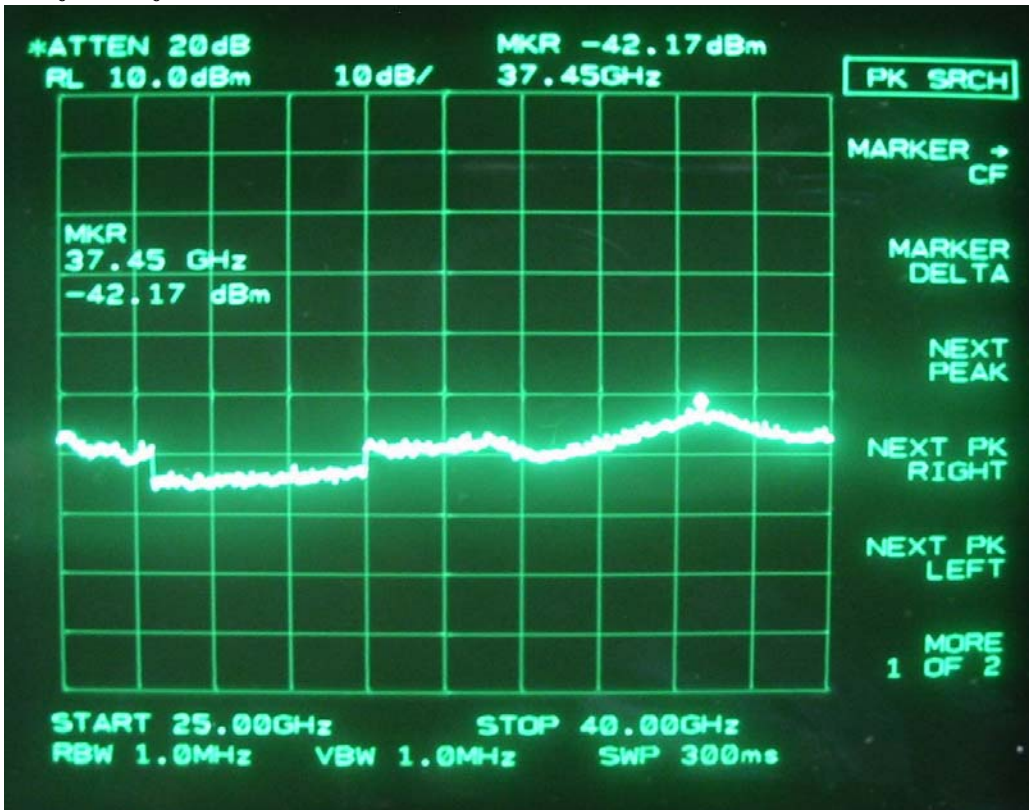

IEEE 802.11a 20M, 5180MHz (Antenna#2)
30MHz-1GHz

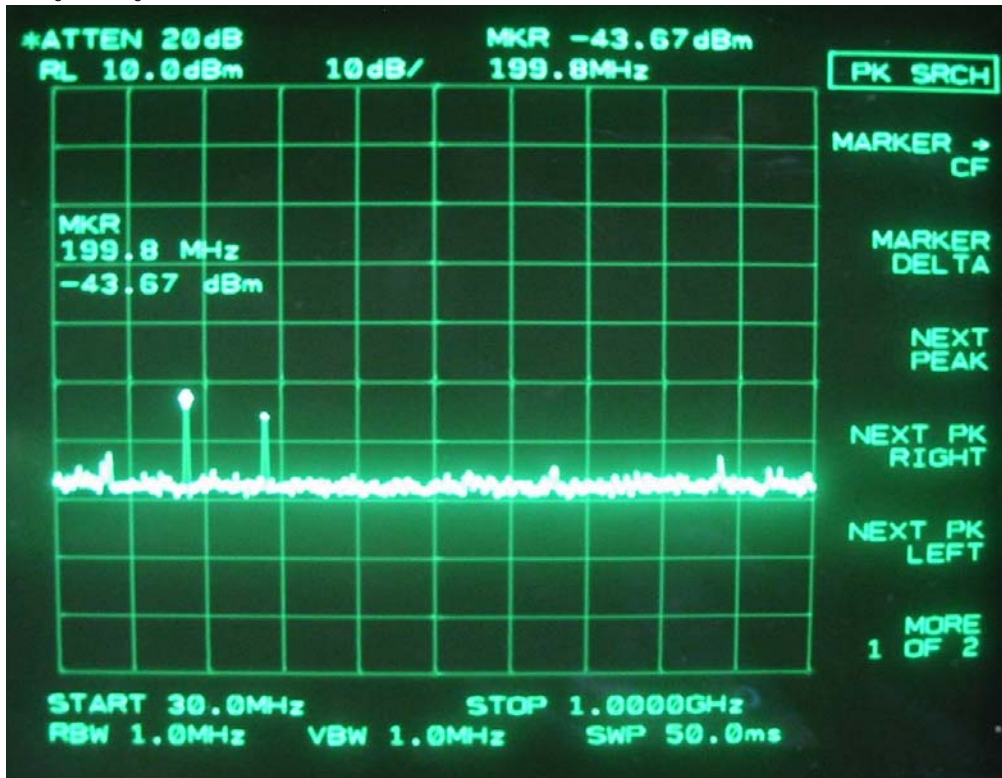

1GHz-10GHz

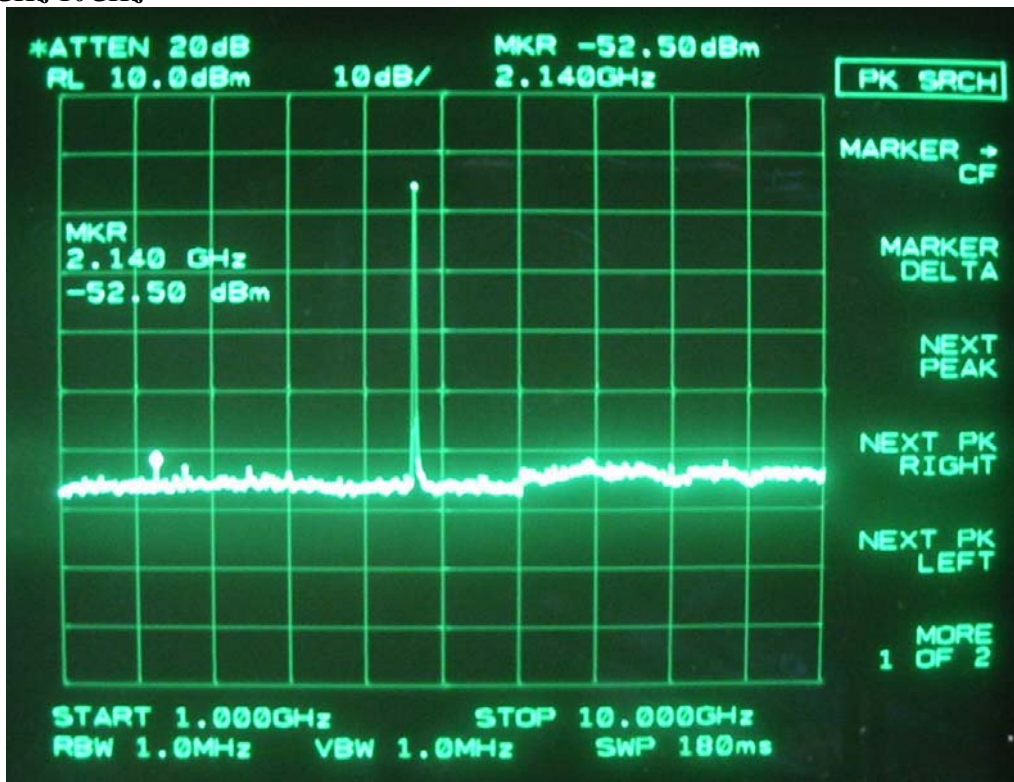

10GHz-25GHz

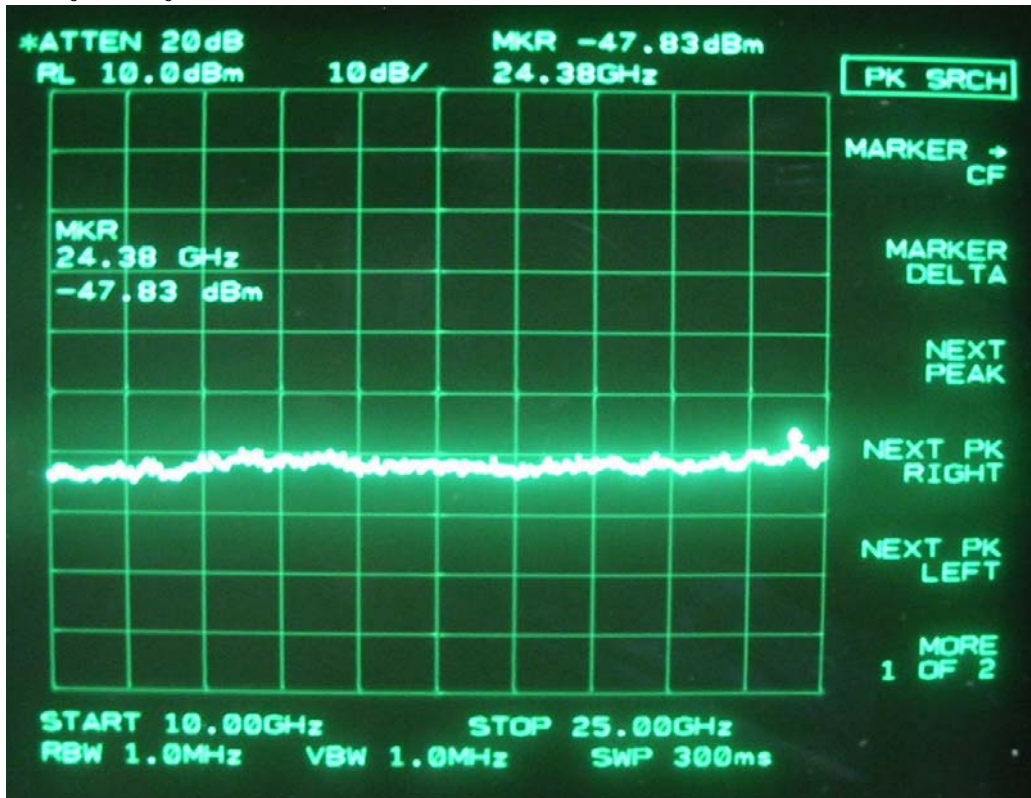

25GHz-40GHz

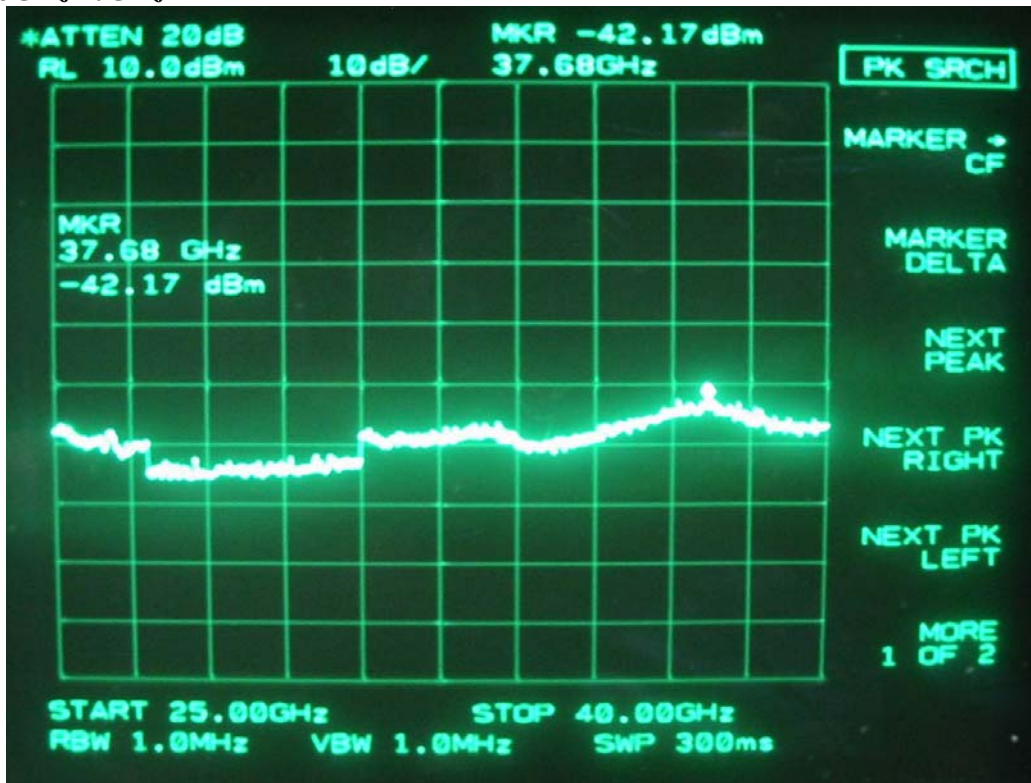

IEEE 802.11a 20M, 5200MHz (Antenna#1)
30MHz-1GHz

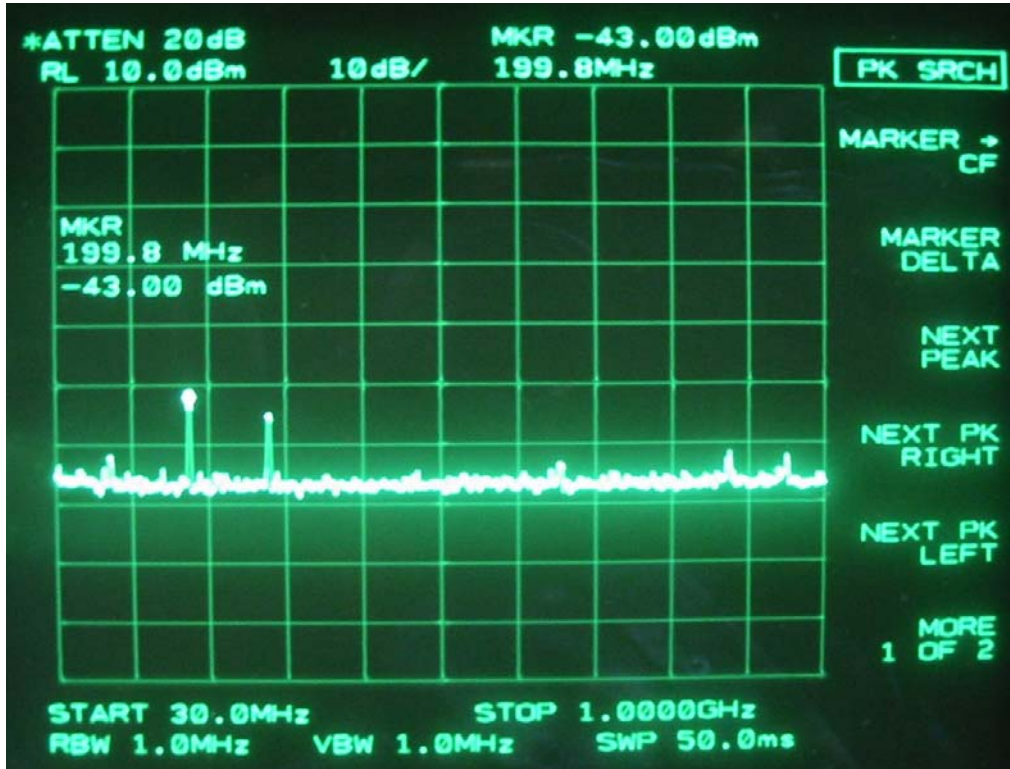

1GHz-10GHz

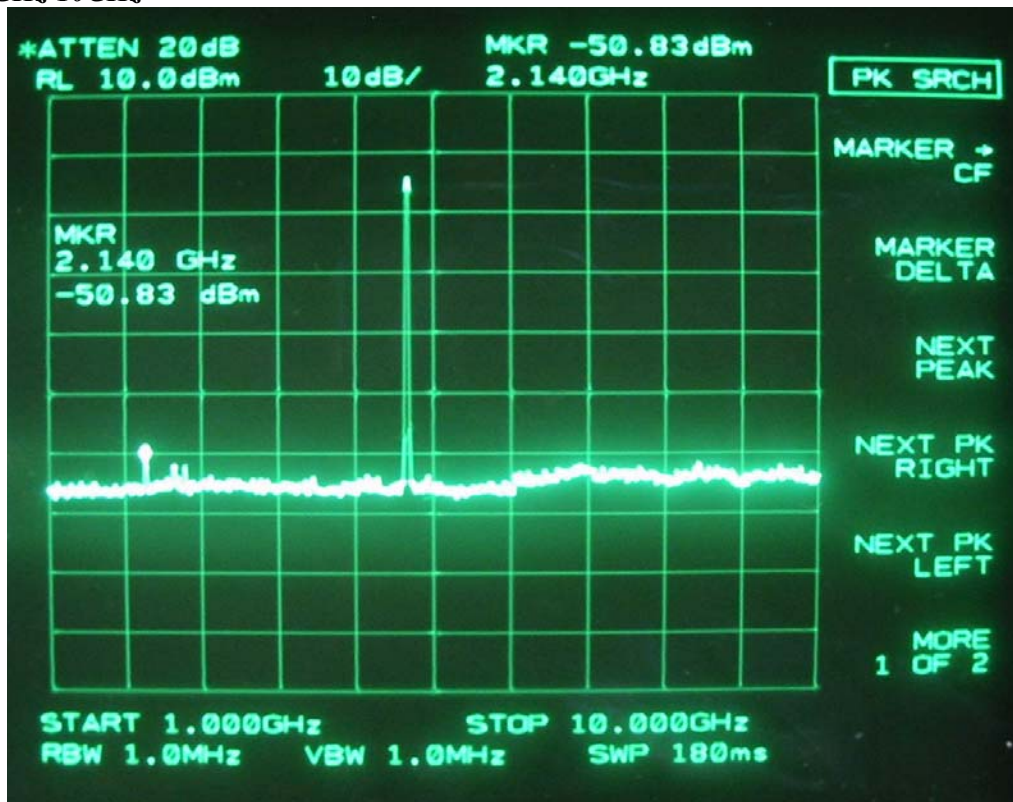

10GHz-25GHz

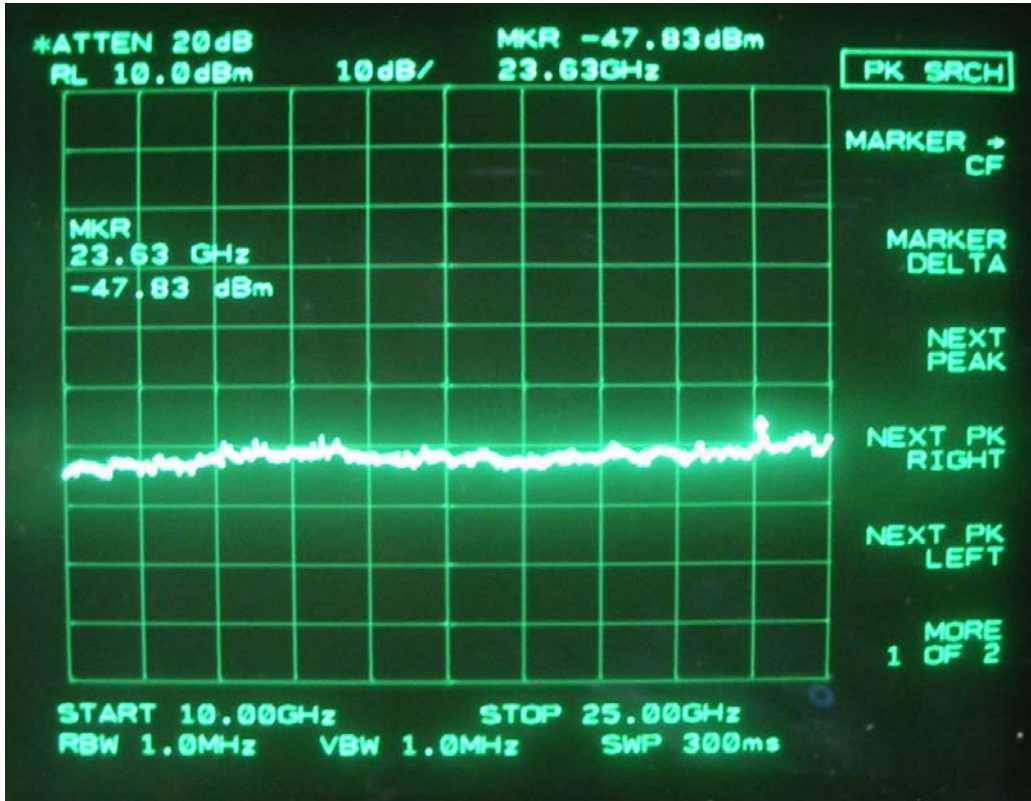

25GHz-40GHz

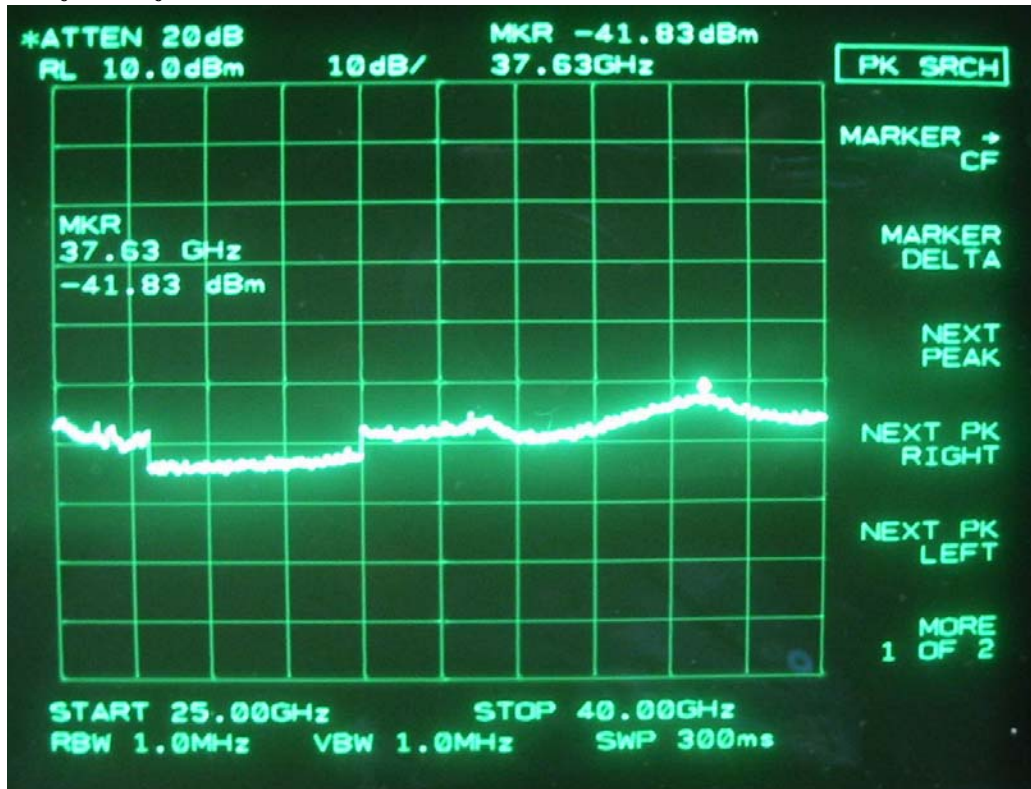

IEEE 802.11a 20M, 5200MHz (Antenna#2)
30MHz-1GHz

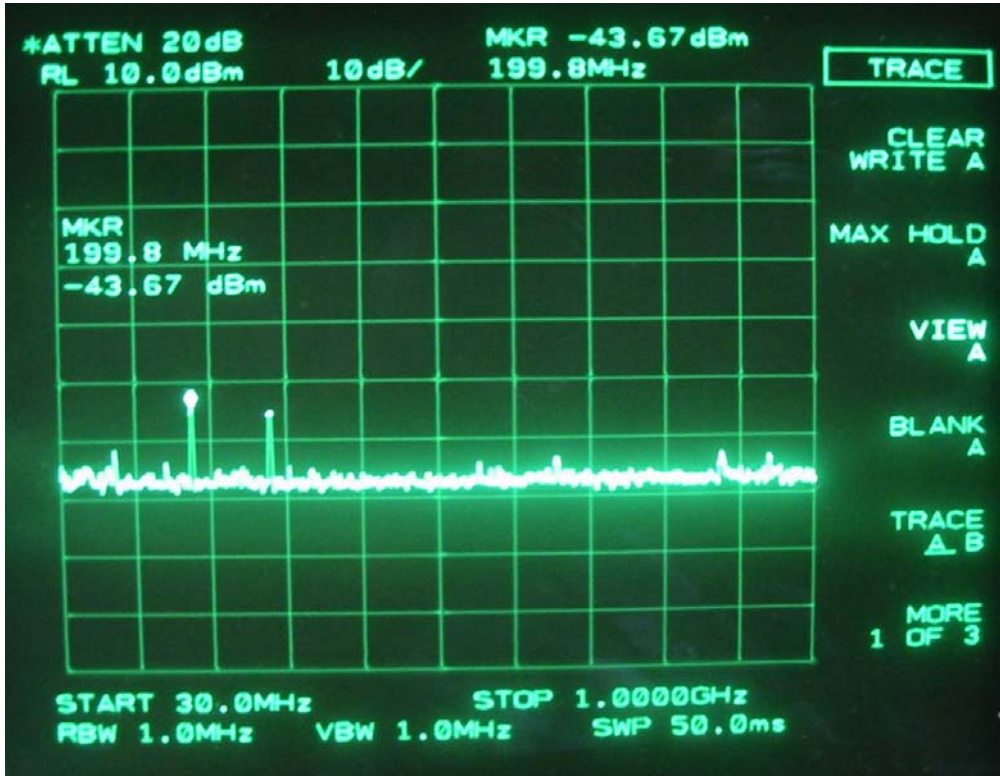

1GHz-10GHz

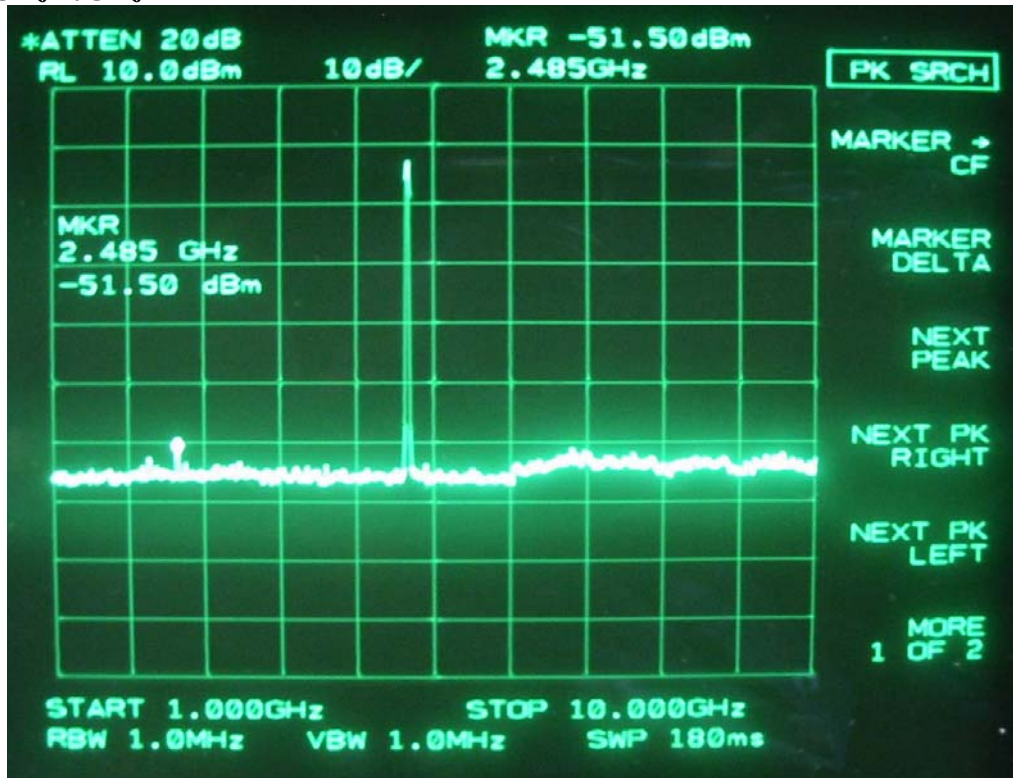

10GHz-25GHz

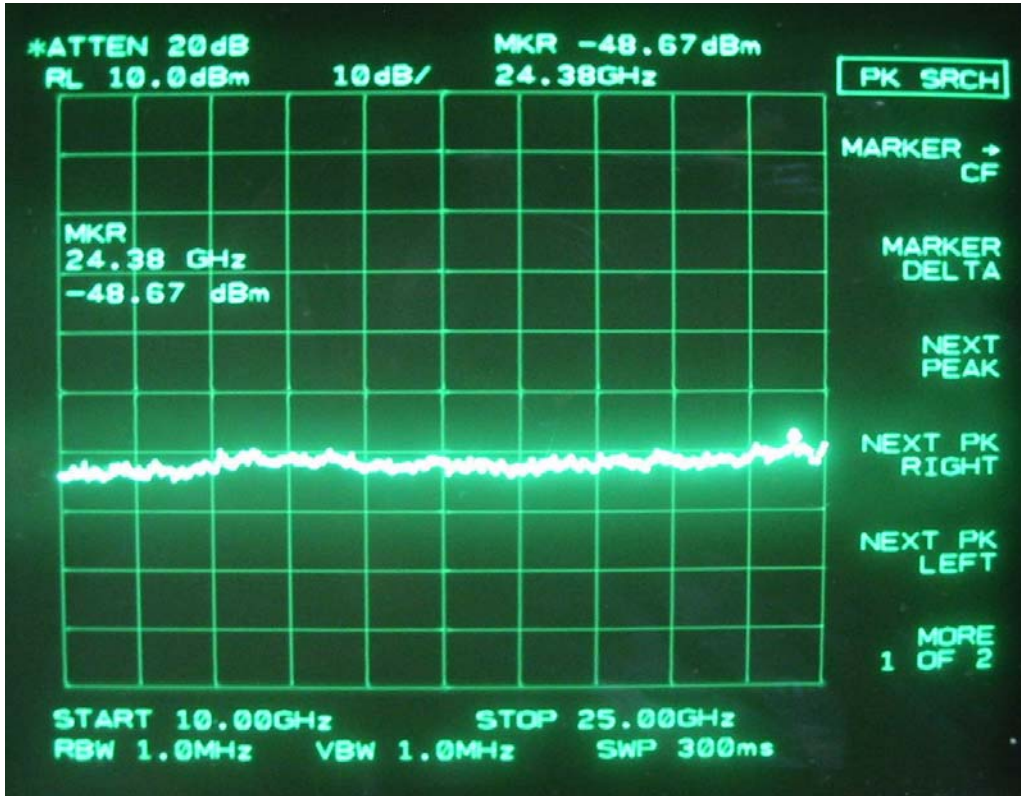

25GHz-40GHz

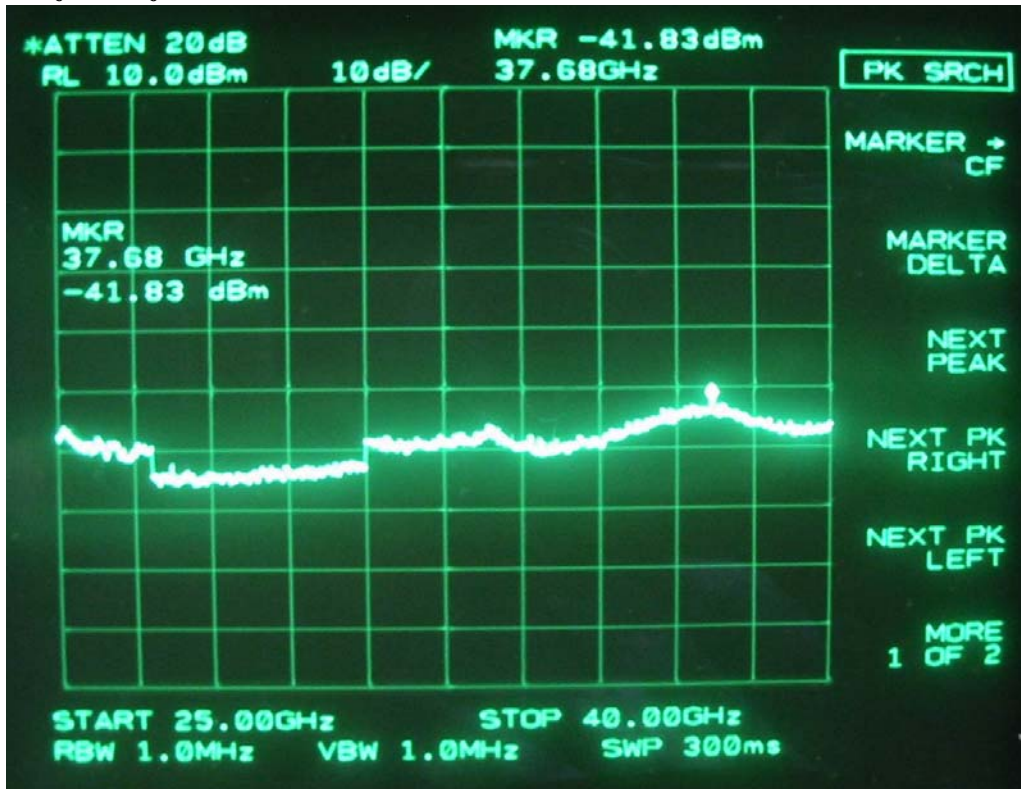

IEEE 802.11a 20M, 5240MHz (Antenna#1)

30MHz-1GHz

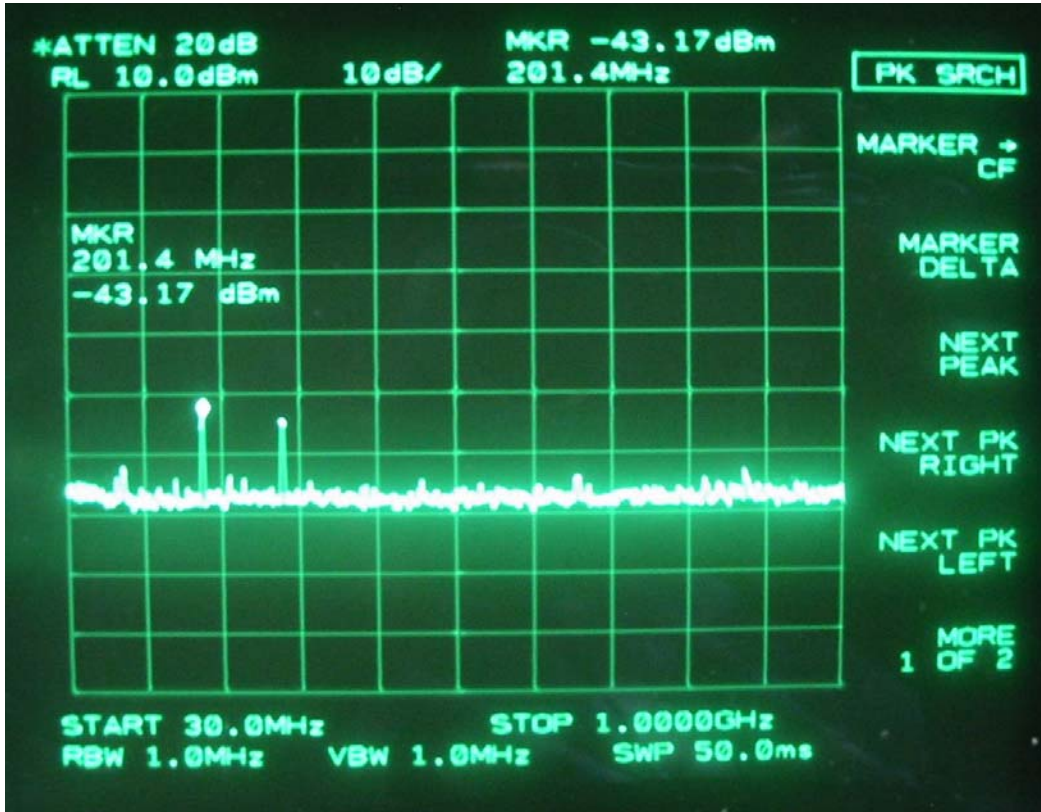

1GHz-10GHz

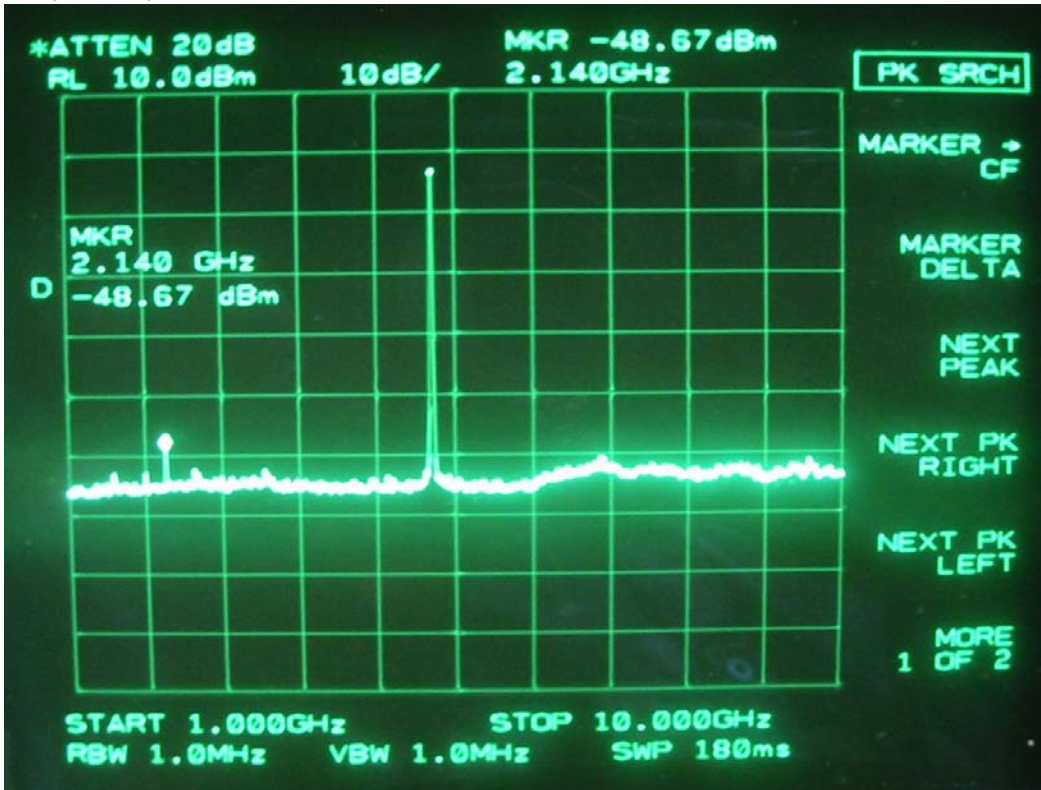

10GHz-25GHz

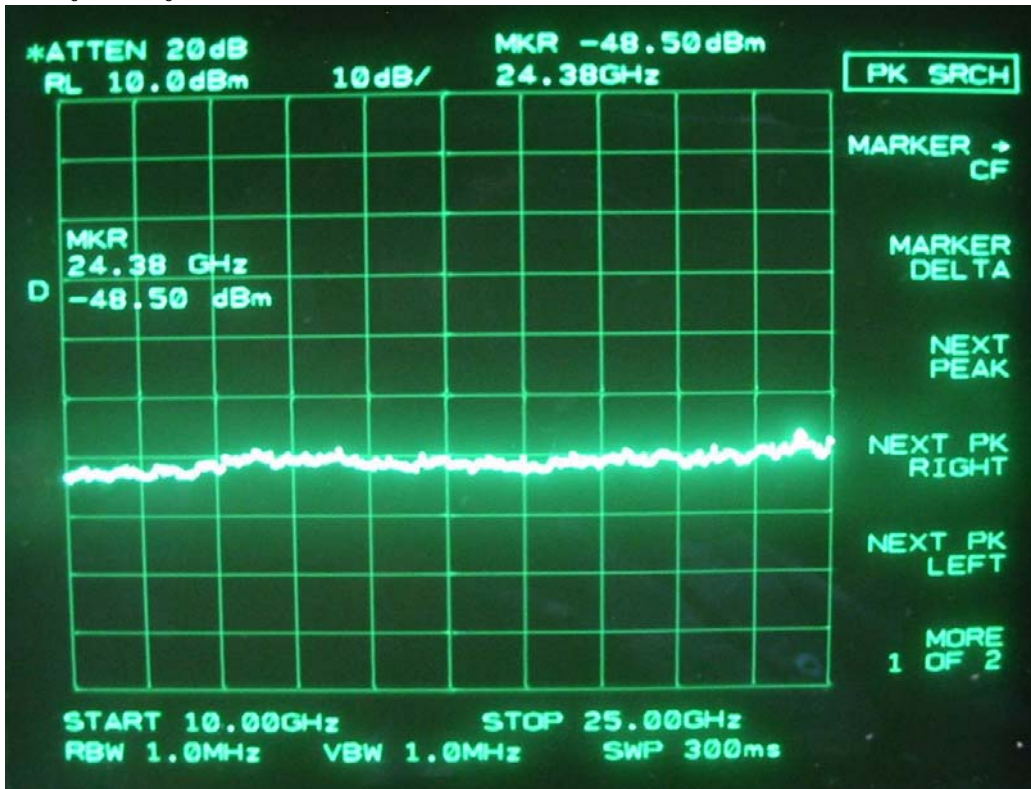

25GHz-40GHz

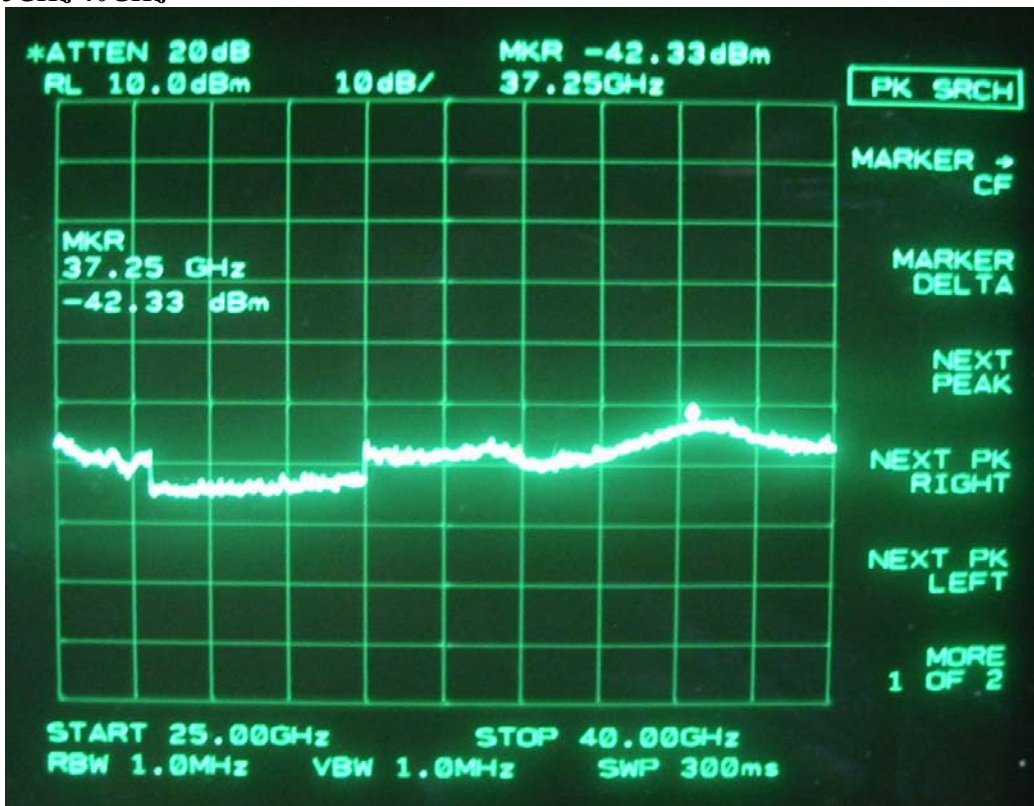

IEEE 802.11a 20M, 5240MHz (Antenna#2)

30MHz-1GHz

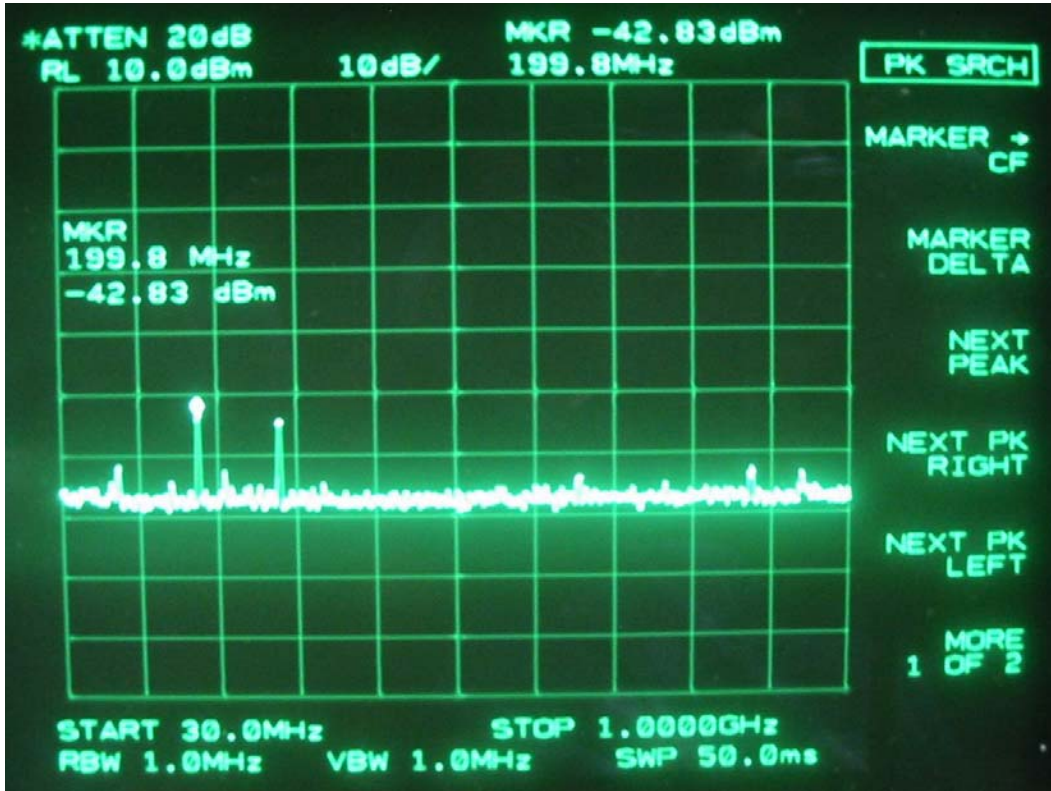

1GHz-10GHz

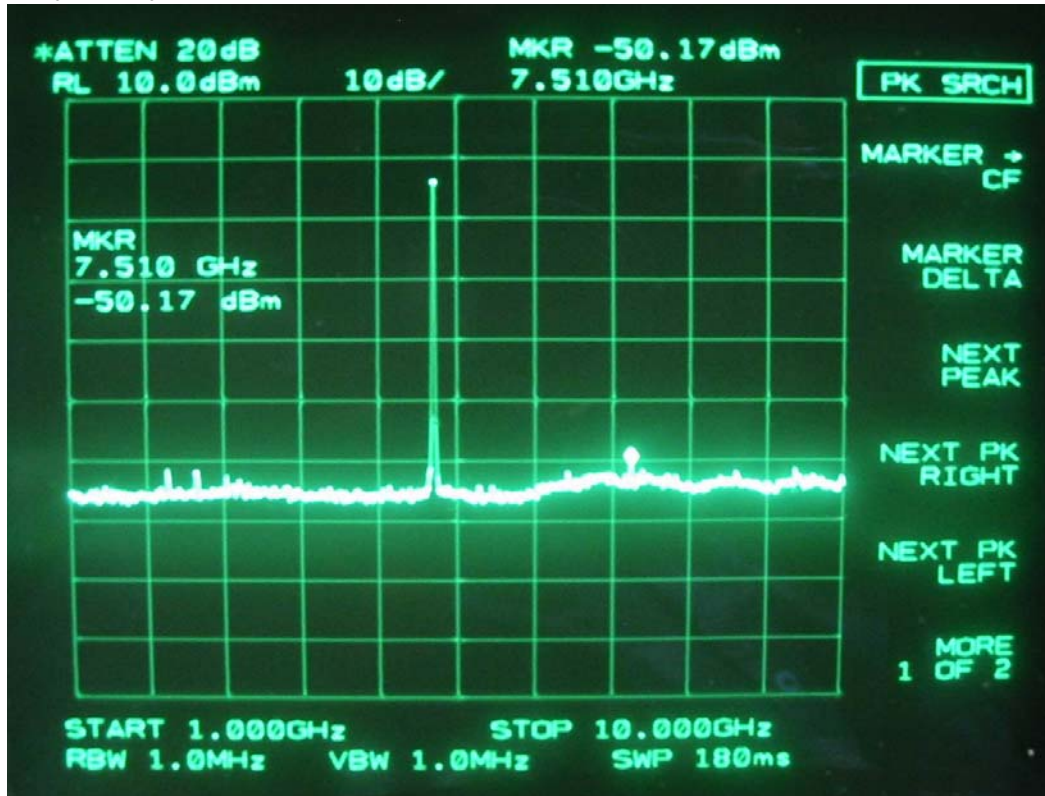

10GHz-25GHz

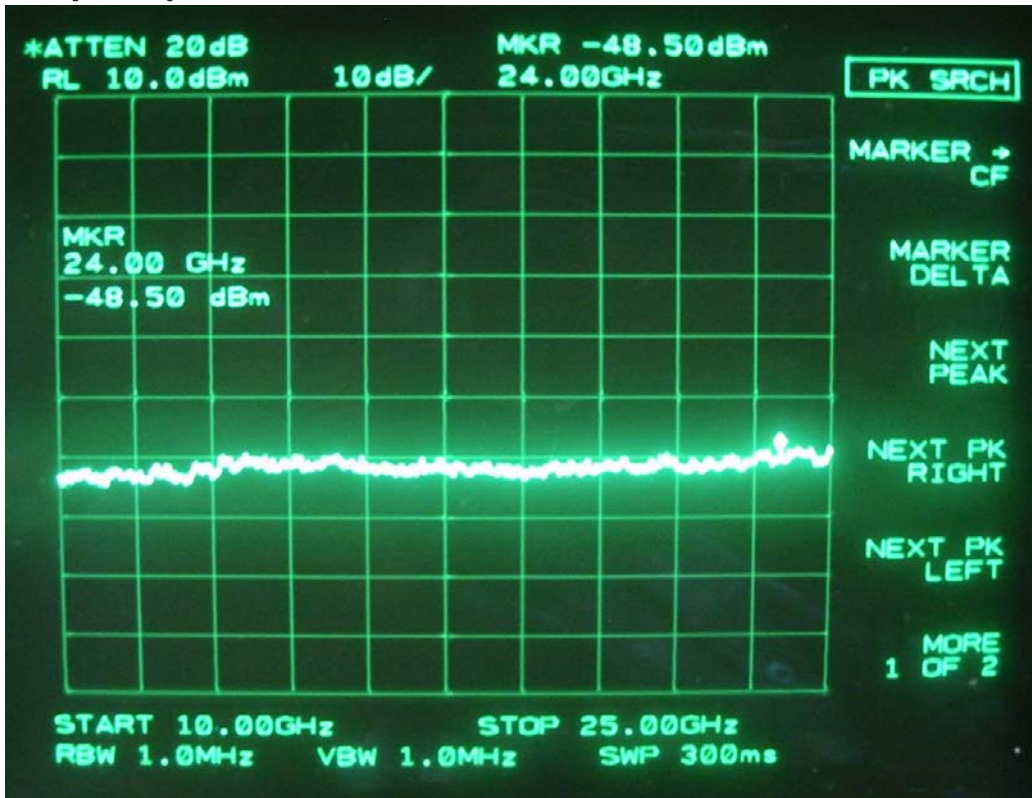

25GHz-40GHz

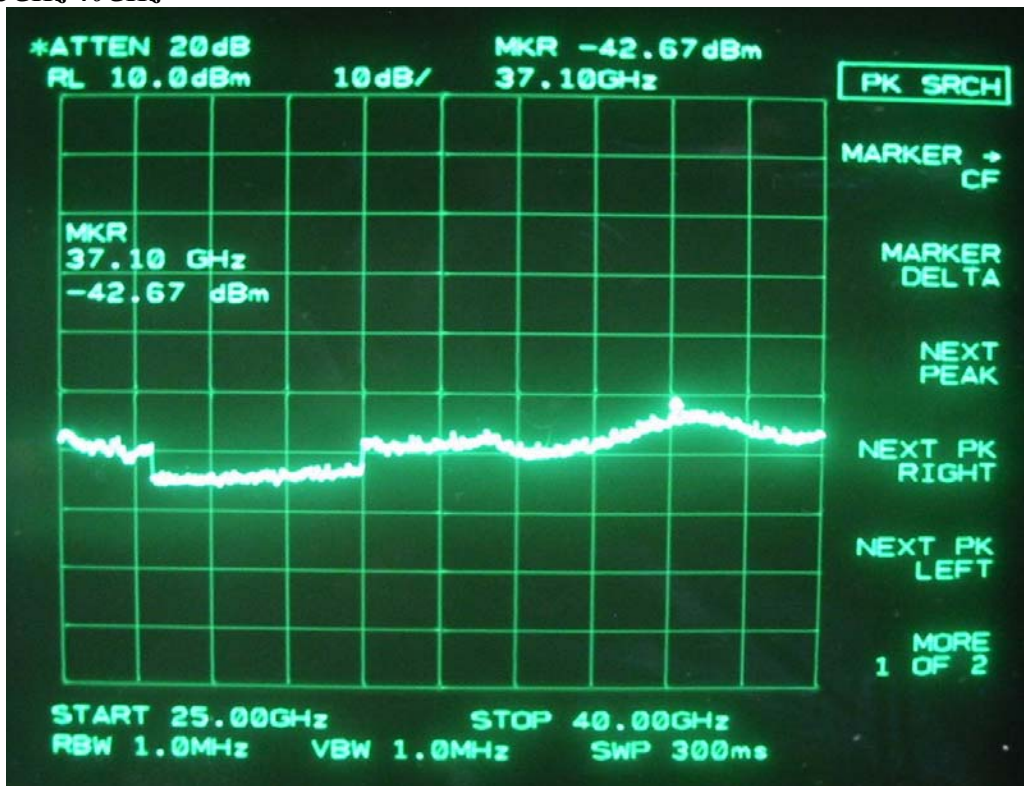

IEEE 802.11a 40M, 5190MHz (Antenna#1)
30MHz-1GHz

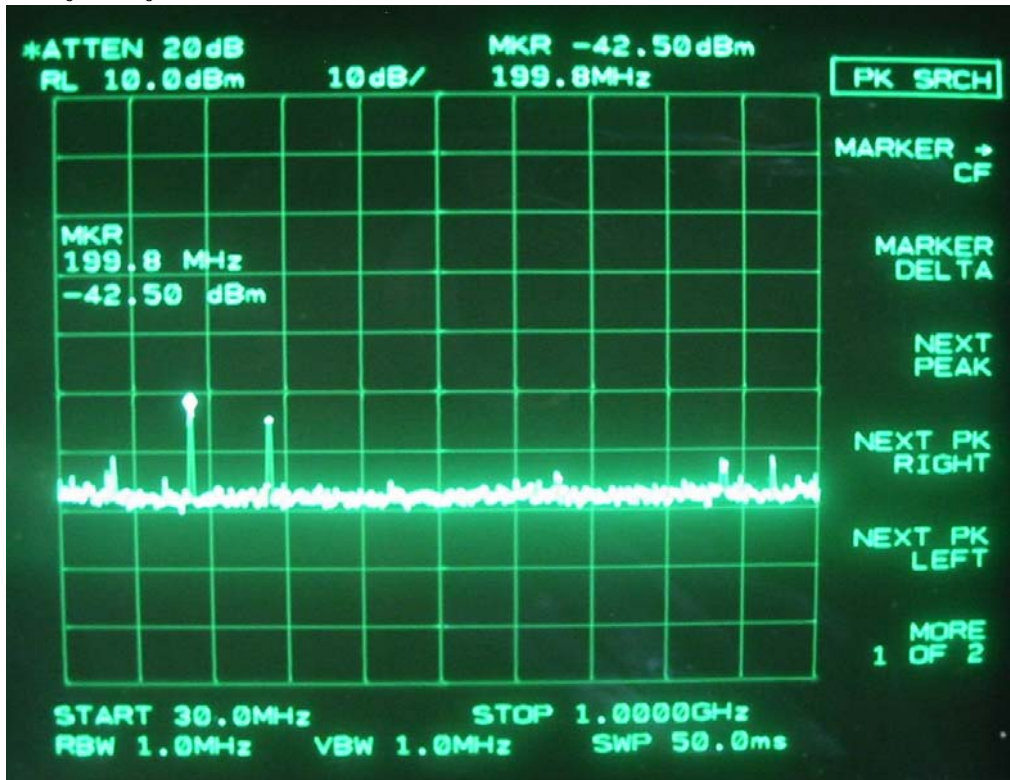

1GHz-10GHz

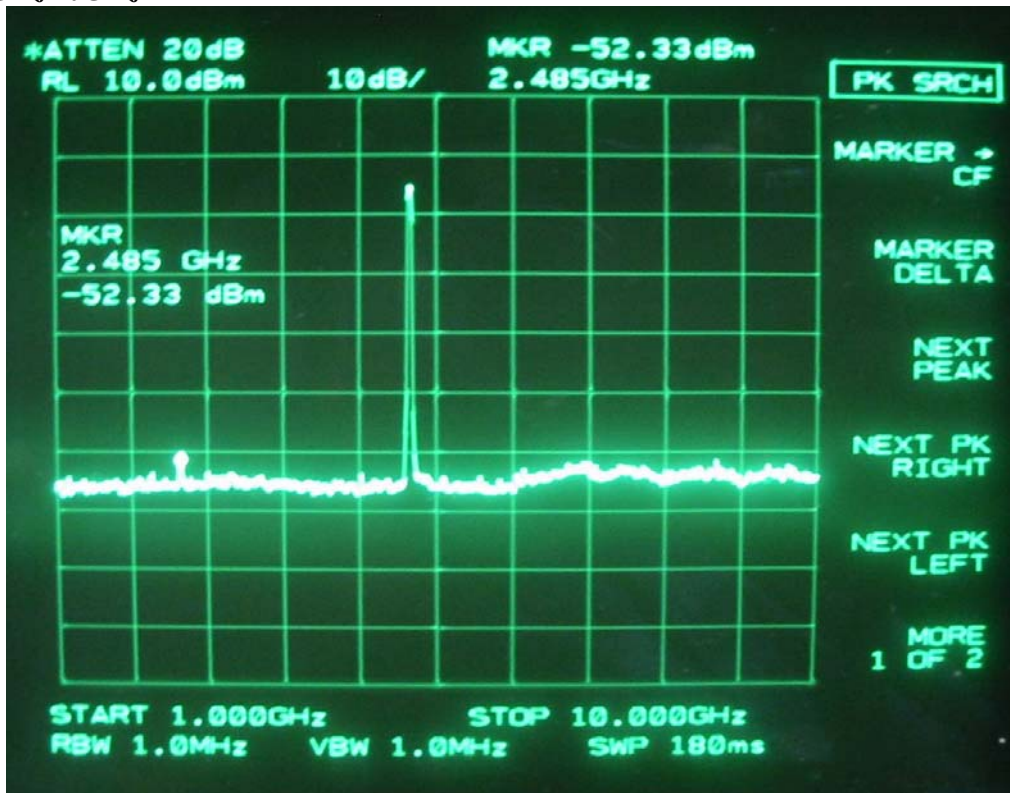

10GHz-25GHz

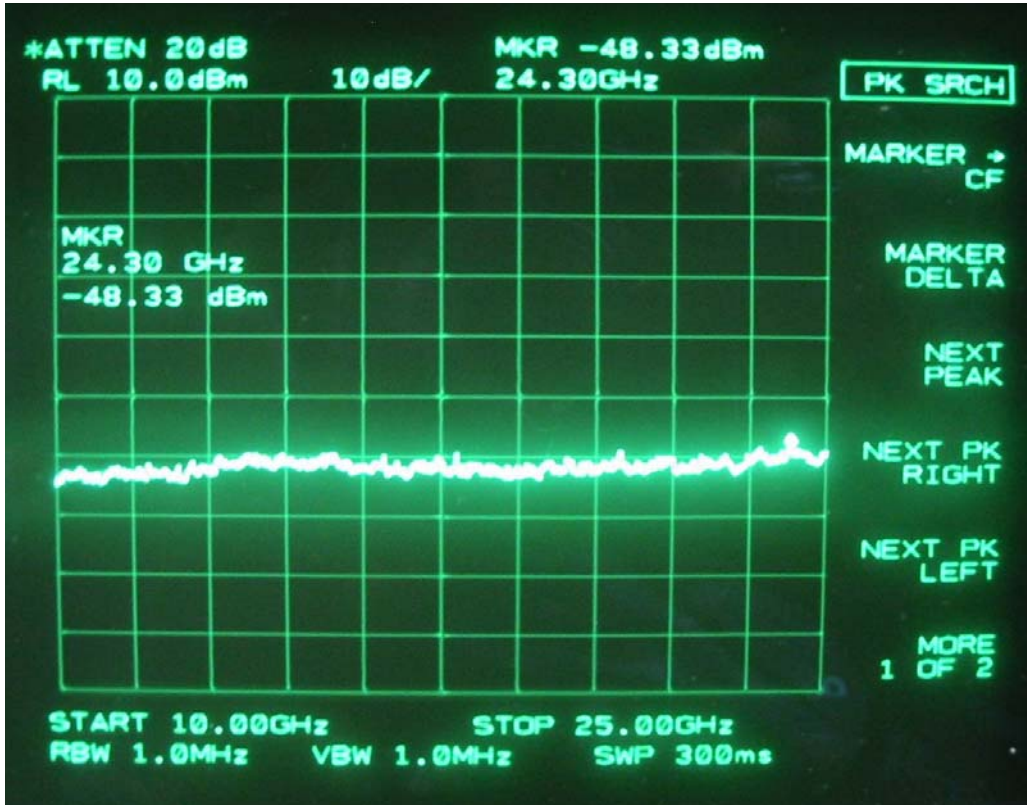

25GHz-40GHz

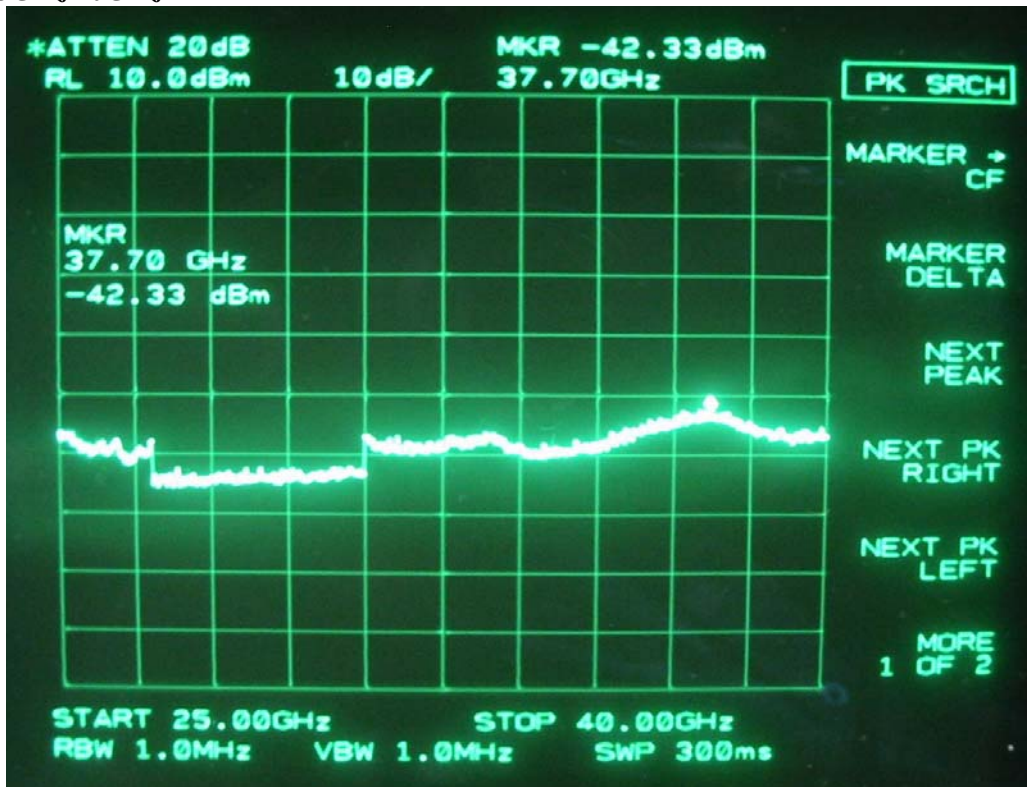

IEEE 802.11a 40M, 5190MHz (Antenna#2)
30MHz-1GHz

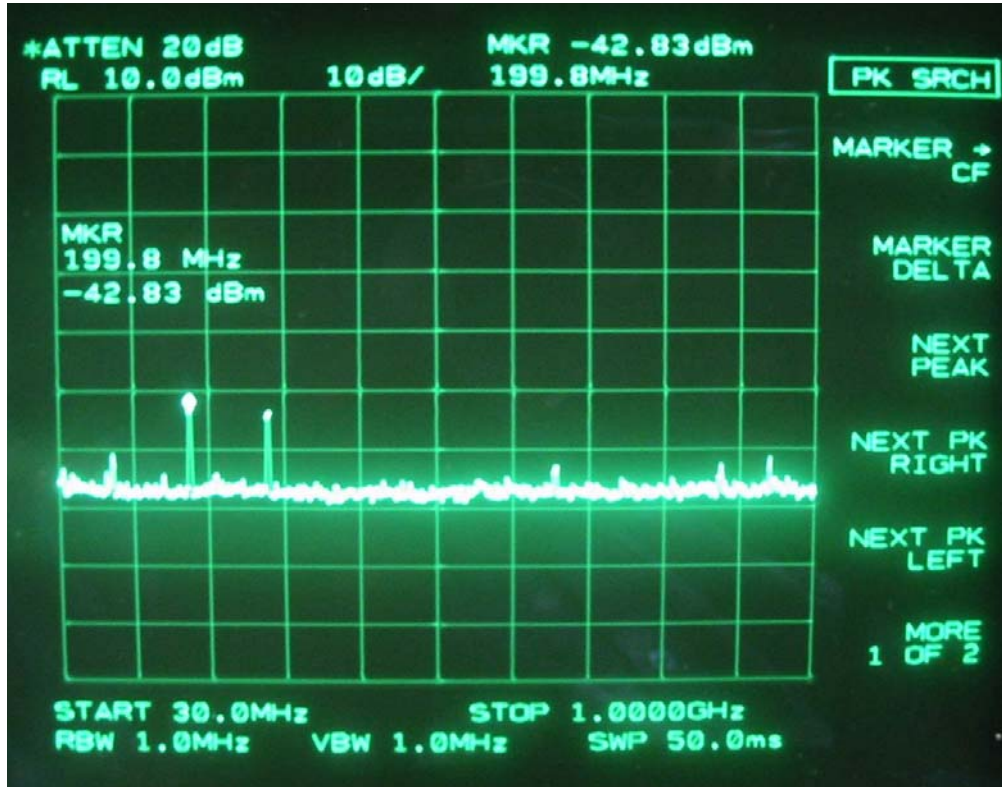

1GHz-10GHz

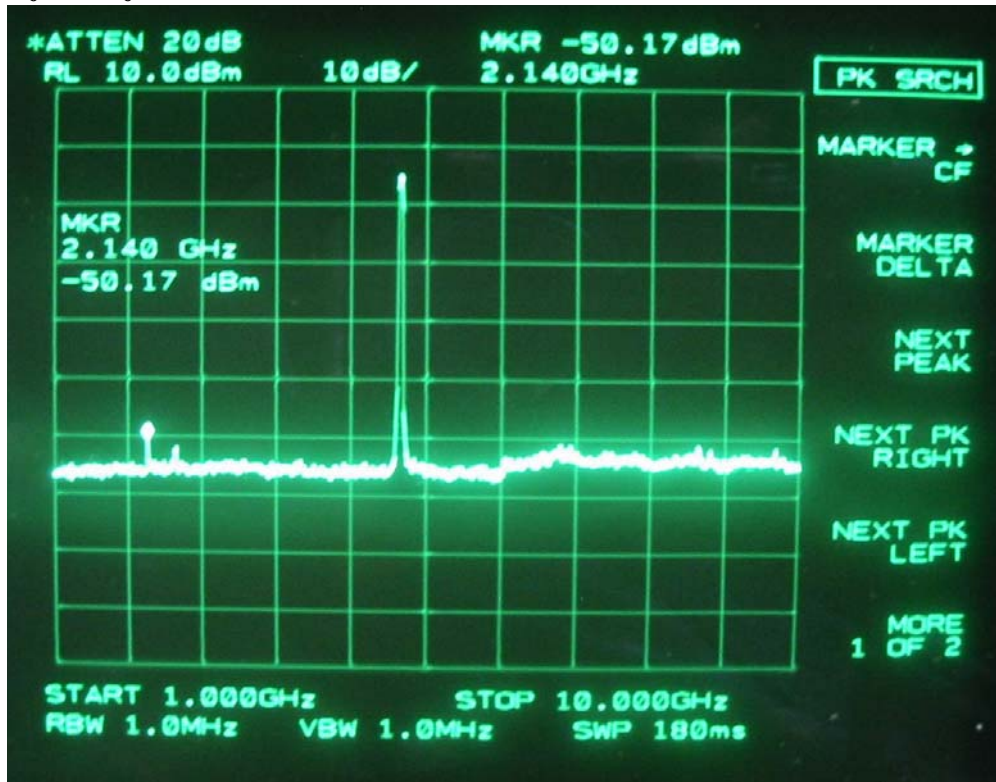

10GHz-25GHz

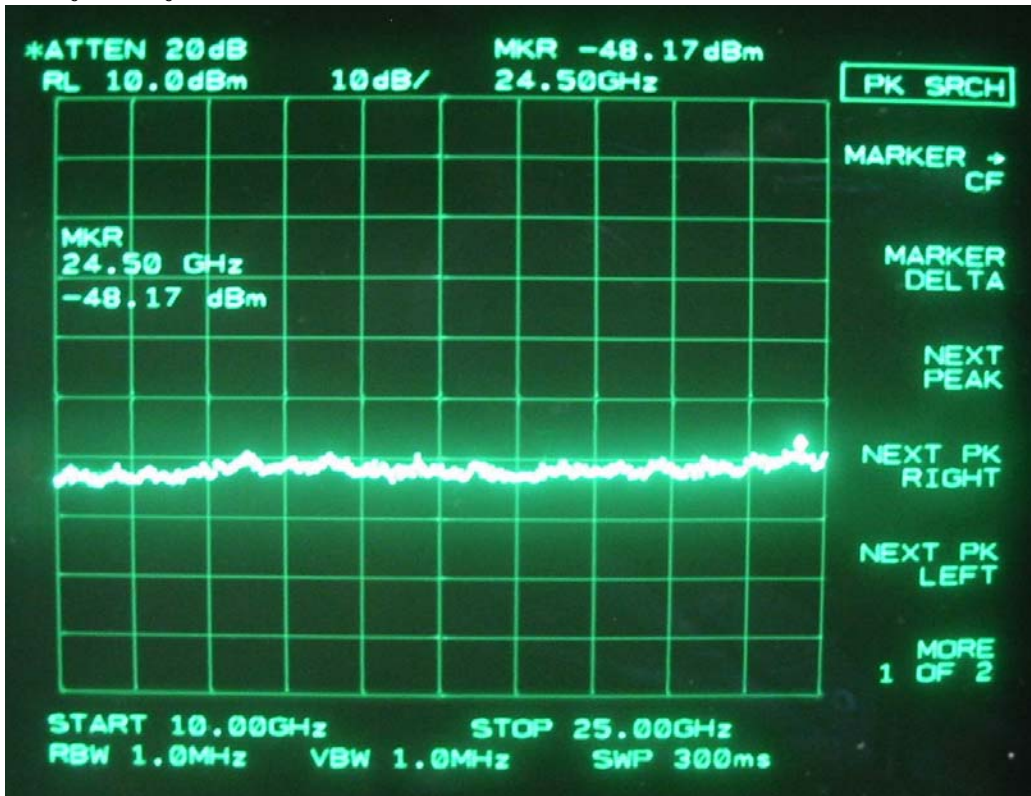

25GHz-40GHz

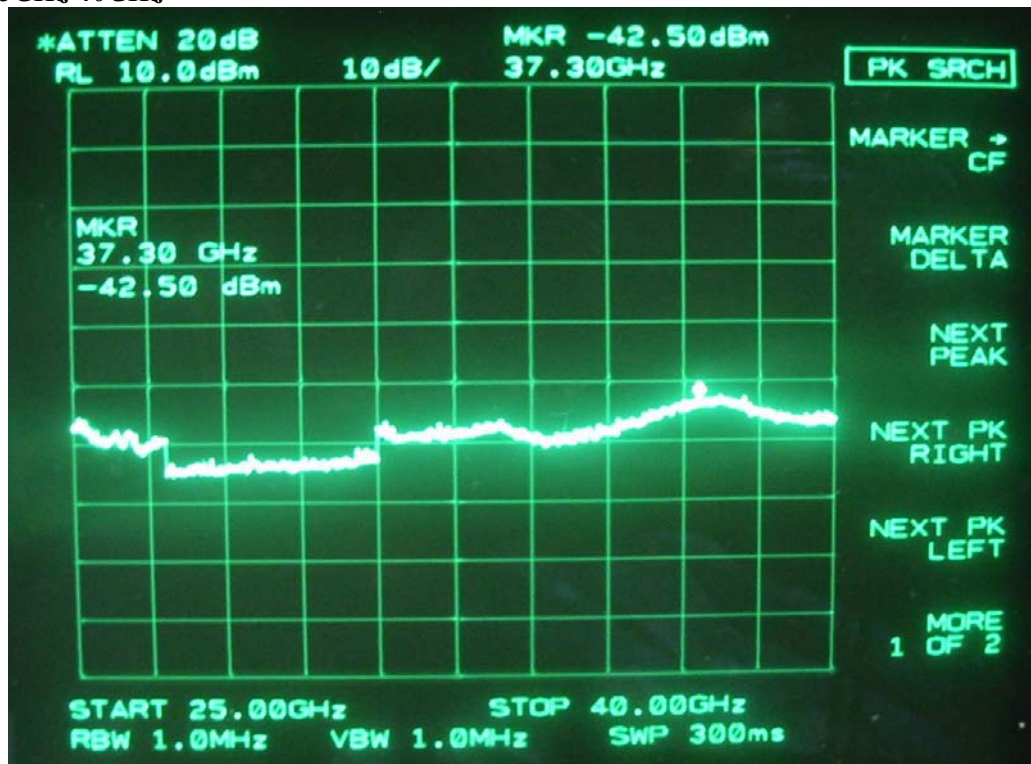

IEEE 802.11a 40M, 5230MHz (Antenna#1)

30MHz-1GHz

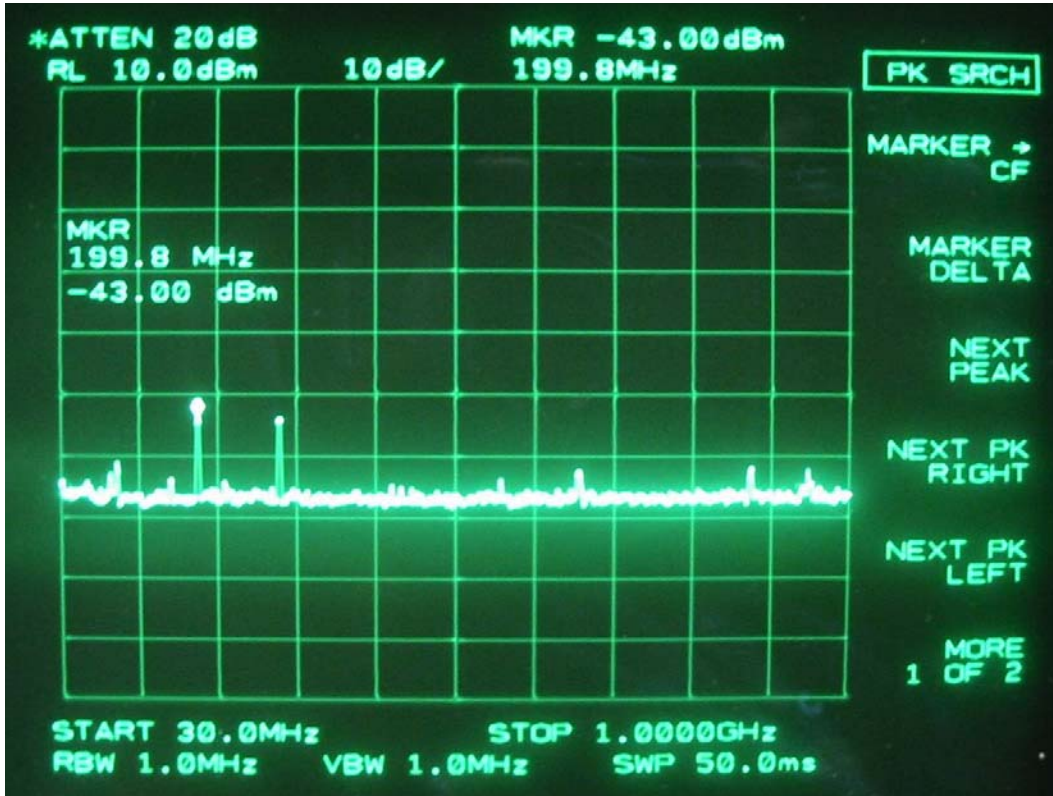

1GHz-10GHz

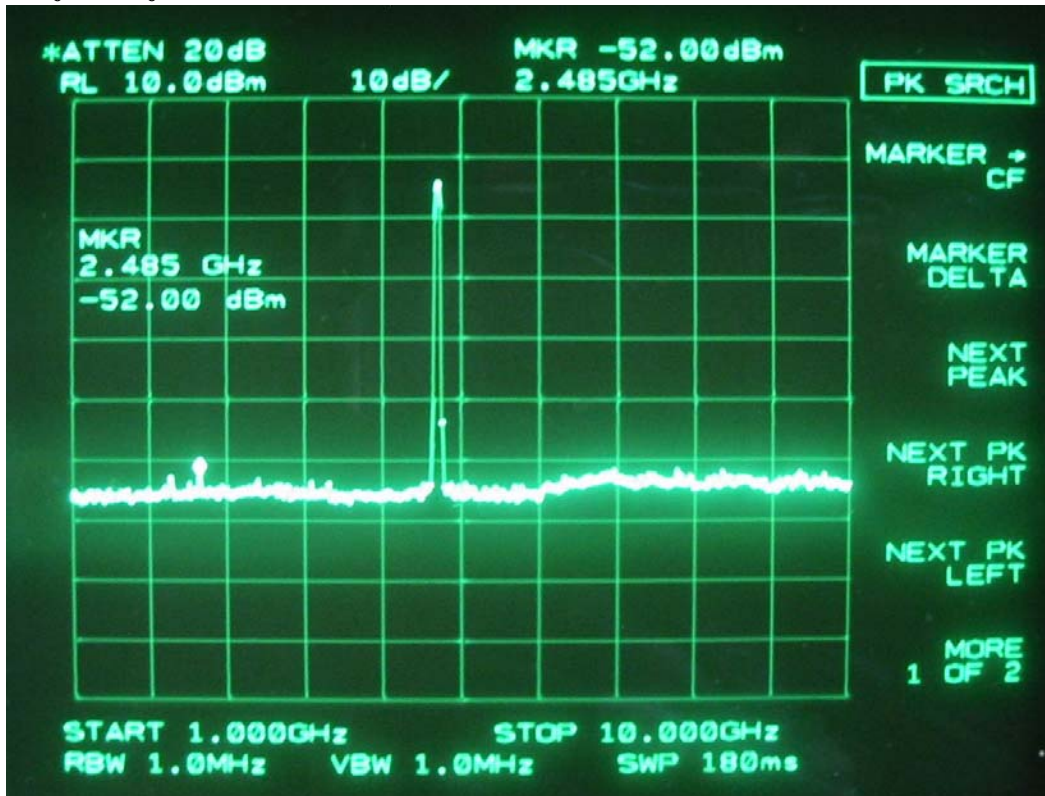

10GHz-25GHz

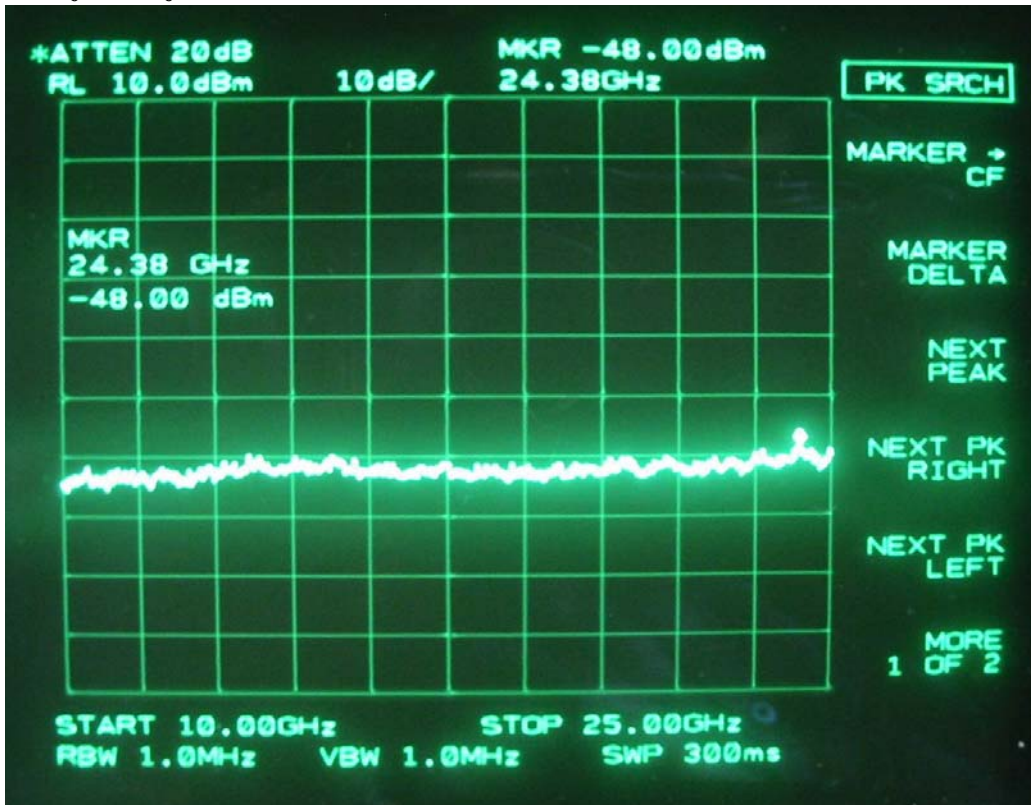

25GHz-40GHz

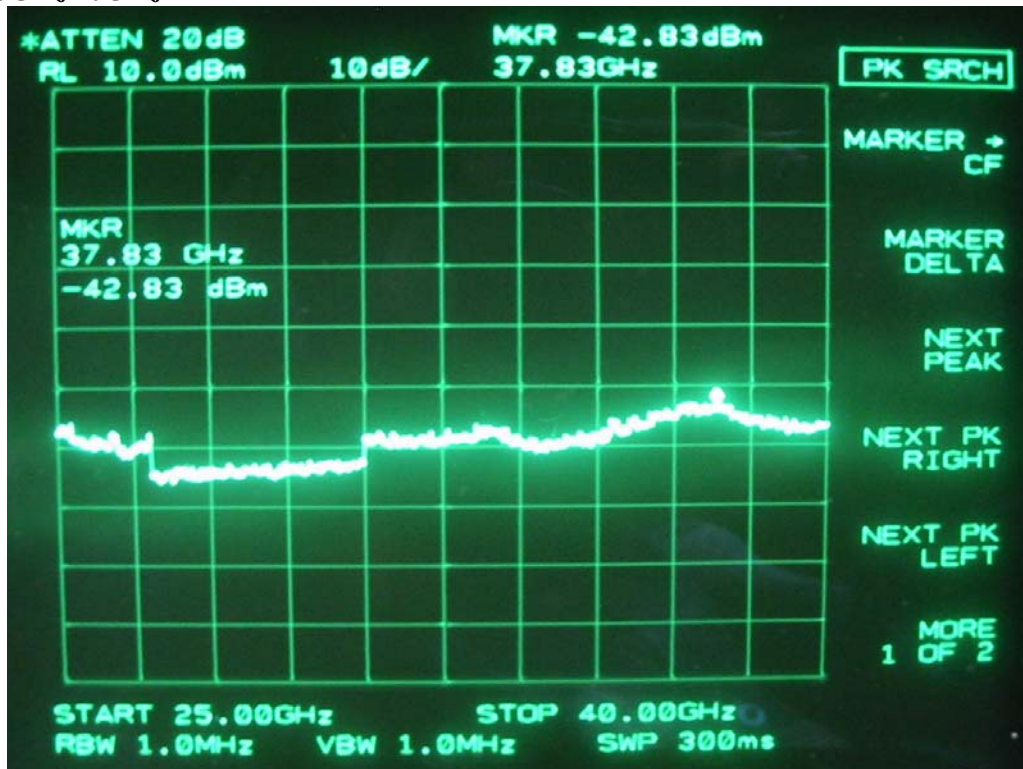

IEEE 802.11a 40M, 5230MHz (Antenna#2)

30MHz-1GHz

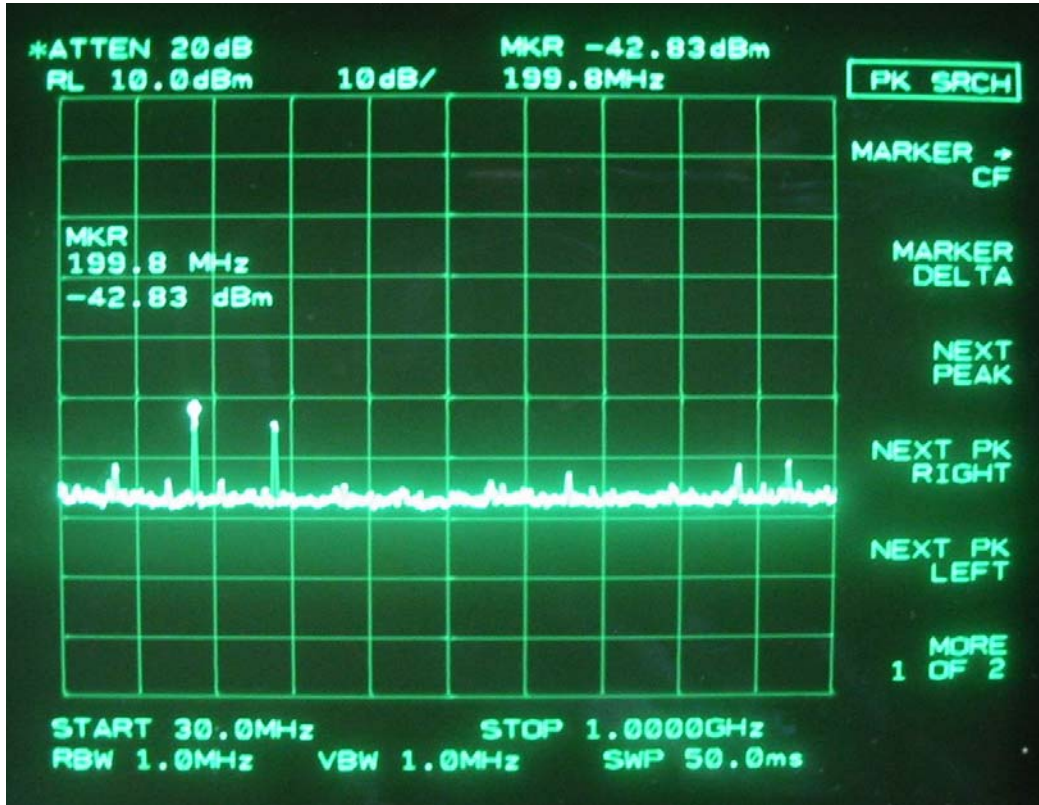

1GHz-10GHz

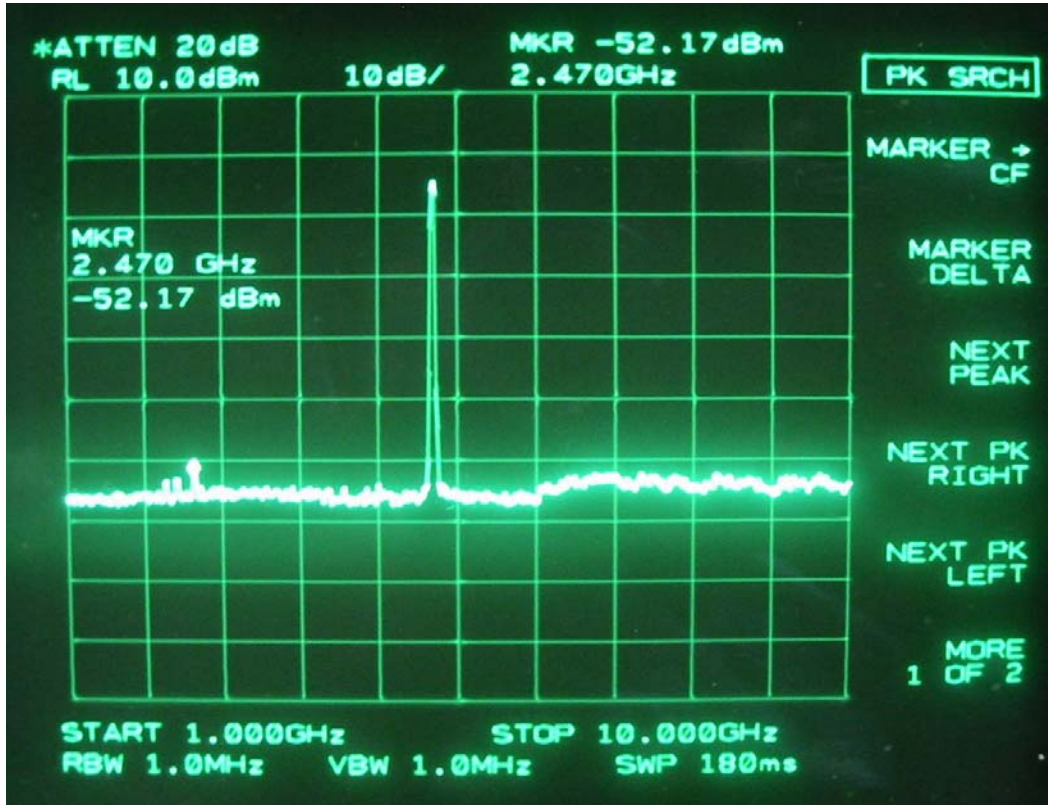

10GHz-25GHz

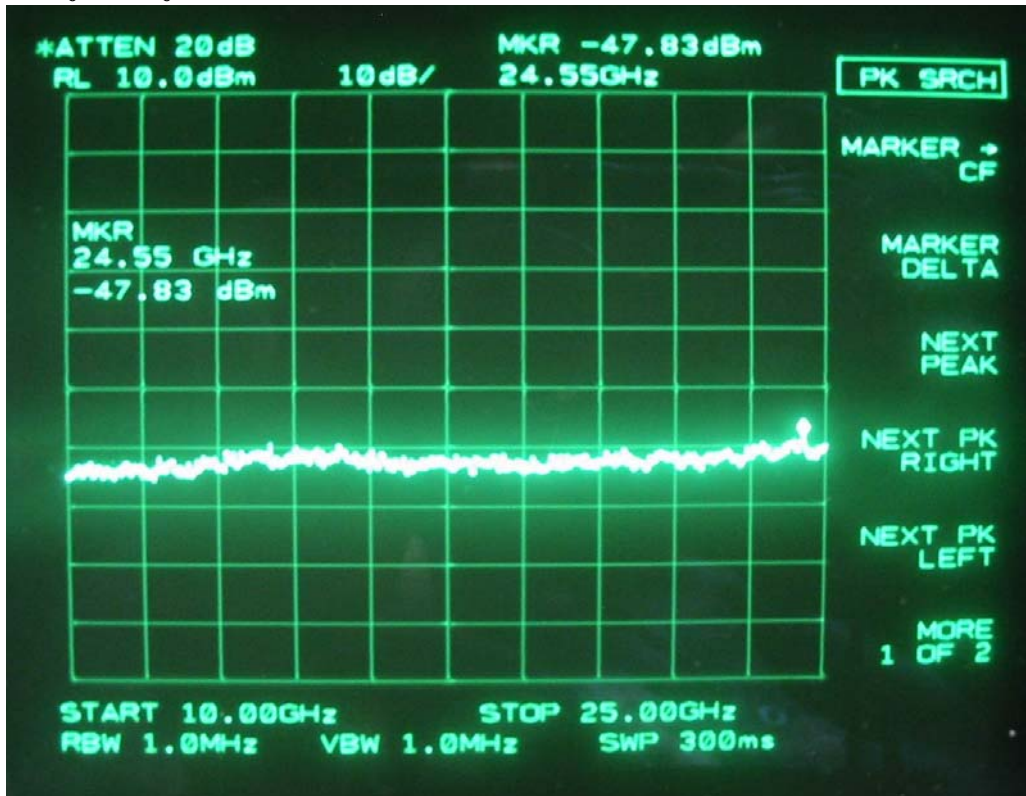

25GHz-40GHz

