

# Description of Operation

- Product Overview and Functional Description

AzureWave Technologies, Inc. introduces the advanced IEEE 802.11a/b/g/n WLAN, Bluetooth and FM combo module - AW-AH640. The module is targeted to mobile and embedded devices which need small footprint package, low power consumption, and multiple OS support. The module supports 2.4GHz and 5GHz bands single-stream IEEE 802.11n MAC/baseband/radio, Bluetooth 4.0 + HS, and FM radio receiver functionality. It also includes an integrated Power Management Unit (PMU), Power Amplifiers (PAs), and a Low Noise Amplifier (LNA) for 2.4GHz and 5GHz WLAN bands, and an integrated 2.4GHz T/R switch to address the needs of mobile devices that require minimal power consumption and compact size. By using AW-AH640, the customers can easily enable the Wi-Fi, BT, FM and NFC embedded applications with the benefits of high design flexibility, short development cycle, and quick time-to-market.

For the WLAN operation, the AW-AH640 uses DSSS, OFDM, DBPSK, DQPSK, CCK and QAM baseband modulation technologies. It supports 20 MHz and 40 MHz channels provide PHY layer rates up to 150 Mbps. A high level of integration and full implementation of the power management functions specified in the IEEE 802.11 standard minimize the system power requirements by using AW-AH640. In addition to the support of WPA/WPA2 (personal) and WEP encryption, the AW-AH640 also supports the IEEE 802.11i security standard through AES and TKIP acceleration hardware for faster data encryption. The AW-AH640 is also Cisco Compatible Extension (CCX) certified. For the video, voice and multimedia applications the AW-AH640 support 802.11e Quality of Service (QoS). Two alternative host interface options are included: an SDIO v2.0 interface (including gSPI) and a High-Speed Inter-Chip (HSIC) interface (a USB 2.0 derivative for short-distance onboard connections).

For Bluetooth operation, the AW-AH640 is Bluetooth 4.0 + HS compliant. The Bluetooth transmitter also features a Class 1 power amplifier with Class 2 capability. The AW-AH640 supports extended Synchronous Connections (eSCO), for enhanced voice quality by allowing for retransmission of dropped packets, and Adaptive Frequency Hopping (AFH) for reducing radio frequency interference. It also incorporates all Bluetooth 4.0 features including Secure Simple Pairing, Sniff Subrating, and Encryption Pause and Resume. An independent, high-speed UART is provided for the Bluetooth host interface. The Bluetooth subsystem presents a standard Host Controller Interface (HCI) via a high speed UART and PCM for audio.

## **WLAN Functional Description:**

EUT is a [Tablet Computer](#) that supports WLAN function and operates with [14](#) channels in 2.4GHz and channel 36, 40, 44, 48, 52, 56, 60, 64, 100, 104, 108, 112, 116, 132, 136, 140, 149, 153, 157, 161, 165 in 5GHz. The device provides transmitting speed [1/2/5.5/11](#) Mbps for 802.11b mode, [6/9/12/18/24/36/48/54](#) Mbps for 802.11a mode and 802.11g.

The WLAN antenna type is [chip](#) antenna with peak gain 2.3dBi for 2.4GHz and 0.8dBi for 5GHz. There is a [37.4MHz](#) crystal for the WLAN operation. Operating in 2.4G/5GHz with Direct Sequence Spread Spectrum (DSSS) and Orthogonal Frequency Division Multiplexing (OFDM) modulated radio transmission. It allows your [Tablet Computer](#) to connect to a wireless network and to share resources, such as files or printers without being bound to the network wires. Other details related to operation, please refer to the user manual.

## **Bluetooth Functional Description:**

EUT is a [Tablet Computer](#) that supports Bluetooth 3.0 ([79](#) channels ; including EDR 2, 3Mbps) and Bluetooth 4.0 ([40](#) channels). The modulation of Bluetooth is GFSK,  $\pi/4$ -DQPSK, 8-DPSK. The device adopts Frequency Hopping Spread Spectrum technology (FHSS).

The BT antenna type is [chip](#) antenna with peak gain 2.3dBi. There is a [37.4MHz](#) crystal for the BT operation. When you enable the application program of Bluetooth, many wireless applications will become possible, such as: Communicate with each other wirelessly (between embedded systems, laptops, PCs, and others), including sharing or exchanges of data. BT and WLAN (Main) share the same antenna but won't transmit simultaneously.

### Security

- ◆ WPA™- and WPA2™- (Personal) support for powerful encryption and authentication
- ◆ AES and TKIP acceleration hardware for faster data encryption and 802.11i compatibility
- ◆ Cisco® Compatible Extension- (CCX, CCX 2.0, CCX 3.0, CCX 4.0, CCX5.0) certified
- ◆ Secure Easy Setup™ for simple Wi-Fi® setup and WPA2/WPA security configuration
- ◆ Wi-Fi Protected Setup (WPS)
- ◆ WEP
- ◆ WMM / WMM-SA
- ◆ CKIP(Software)

## Key Features

### General

- Integrates Broadcom solutions of Azurewave AW-AH640( BCM43340) WiFi /BT /FM SoC
- SDIO v2.0 interfaces support for WLAN
- High speed UART and PCM for Bluetooth
- FM subsystem control through Bluetooth HCI interface
- ECI—enhanced coexistence support, ability to coordinate BT SCO transmissions around WLAN receives
- Flexible Power Supply (2.3V~4.8V), supplies with internal switching regulator.
- Multiple power saving modes for low power consumption
- Lead-free /Halogen Free Design
- 9.0mm(L) x 9.0mm(W) x 0.956mm(H) 90 pin LGA package

### WLAN Section

- Dual - band 2.4 GHz and 5GHz 802.11 a/b/g/n
- Single-stream IEEE 802.11n support for 20 MHz and 40 MHz channels provides PHY layer rates up to 150 Mbps for typical upper layer throughput in excess of 90 Mbps.
- Supports IEEE 802.11d, e, h, i, r, k, w
- WLAN host interface options
  - SDIO v2.0, including DS and HS modes
  - gSPI – up to 48 MHz clock rate
  - HSIC v1.0(USB device interface for short distance on-board applications)
- Security—WEP, WPA/WPA2 (personal), AES (HW), TKIP (HW), CKIP (SW).
- WMM/WMM-PS/WMM-SA
- Proprietary protocol-CCx/CCXv2/CCXv3/CCXv4/CCXv5, WFAEC
- Integrated CPU with on-chip memory for a complete WLAN subsystem minimizing the need to wake up the applications processor
- Reference WLAN subsystem provides Wi-Fi Protected Setup (WPS)

## Bluetooth Section

- Supports extended Synchronous Connections (eSCO), for enhanced voice quality by allowing for retransmission of dropped packets
- Adaptive Frequency Hopping (AFH) for reducing radio frequency interference
- Maximum UART baud rates up to 4 Mbps
- Multipoint operation with up to seven active slaves
- Bluetooth Class 1 or Class 2 transmitter operation
- Supports all Bluetooth 4.0 + HS packet types
- Fully supports Bluetooth Core Specification version 4.0+(Enhanced Data Rate) EDR features:
  - Adaptive Frequency Hopping (AFH)
  - Quality of Service (QoS)
  - Extended Synchronous Connections (eSCO) — Voice Connections
  - Fast Connect (interlaced page and inquiry scans)
  - Secure Simple Pairing (SSP)
  - Sniff Subrating (SSR)
  - Encryption Pause Resume (EPR)
  - Extended Inquiry Response (EIR)
  - Link Supervision Timeout (LST)
- Interface support – Host controller interface (HCI) using a high-speed UART interface and PCM for audio data
- Full support for power savings modes
  - Bluetooth clock request
  - Bluetooth standard sniff
  - Deep-sleep modes and software regulator shutdown

## Block Diagram

A simplified block diagram of the AW-AH640 module is depicted in the figure below.

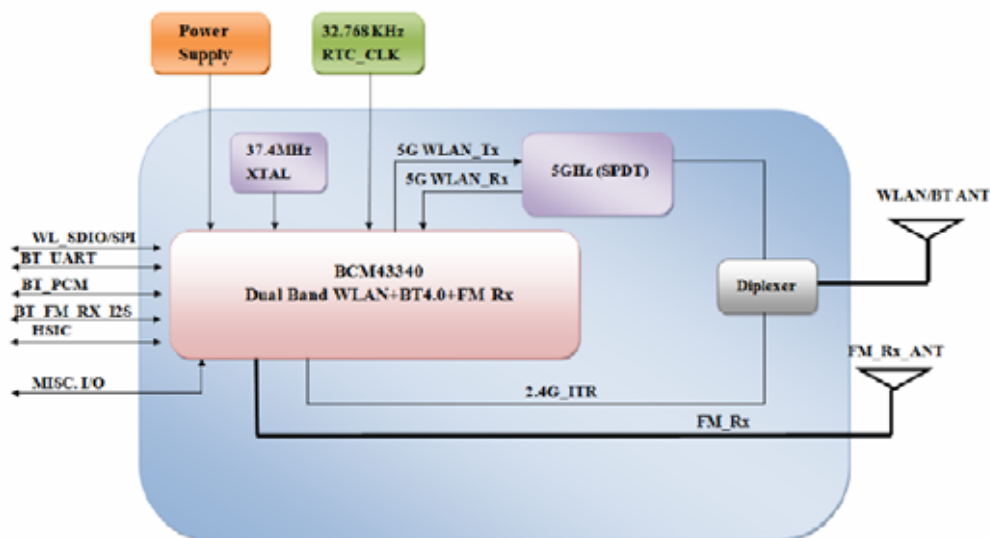

AW-AH640 BLOCK DIAGRAM