

Partial FCC RF Test Report

APPLICANT : PEGATRON CORPORATION
EQUIPMENT : HSPA+ Module
BRAND NAME : HUAWEI
MODEL NAME : MU736
FCC ID : VUIMU736ARC1
STANDARD : FCC 47 CFR Part 2, 22(H), 24(E), 27(L)
CLASSIFICATION : PCS Licensed Transmitter (PCB)

The product was installed into Tablet (Brand Name: TOSHIBA, Model Name: TOSHIBA AT10-A、TOSHIBA AT15-A) during test.

This is a partial report which is included the Conducted Output Power Measurement and ERP/EIRP Measurement, Peak-to-Average Ratio, and Field Strength of Spurious Radiation Measurement. The product was received on Apr. 15, 2013 and completely tested on Apr. 26, 2013. We, SPORTON INTERNATIONAL INC., would like to declare that the tested sample has been evaluated in accordance with the procedures given in ANSI / TIA / EIA-603-C-2004 and shown compliance with the applicable technical standards.

The test results in this report apply exclusively to the tested model / sample. Without written approval of SPORTON INTERNATIONAL INC., the test report shall not be reproduced except in full.



Reviewed by: Joseph Lin / Supervisor



Approved by: Jones Tsai / Manager



SPORTON INTERNATIONAL INC.

No. 52, Hwa Ya 1st Rd., Hwa Ya Technology Park, Kwei-Shan Hsiang, Tao Yuan Hsien, Taiwan, R.O.C.

SPORTON INTERNATIONAL INC.

TEL : 886-3-327-3456

FAX : 886-3-328-4978

FCC ID : VUIMU736ARC1

Page Number : 1 of 41

Report Issued Date : Jul. 08, 2013

Report Version : Rev. 01



TABLE OF CONTENTS

REVISION HISTORY..... 3

SUMMARY OF TEST RESULT 4

1 GENERAL DESCRIPTION 5

 1.1 Applicant..... 5

 1.2 Manufacturer 5

 1.3 Feature of Equipment Under Test..... 5

 1.4 Product Specification of Equipment Under Test 6

 1.5 Maximum ERP/EIRP Power..... 7

 1.6 Testing Site..... 8

 1.7 Applied Standards 8

2 TEST CONFIGURATION OF EQUIPMENT UNDER TEST 9

 2.1 Test Mode..... 9

 2.2 Connection Diagram of Test System 11

 2.3 Support Unit used in test configuration and system 11

 2.4 Measurement Results Explanation Example 12

3 TEST RESULT 13

 3.1 Conducted Output Power Measurement and ERP/EIRP Measurement..... 13

 3.2 Peak-to-Average Ratio 16

 3.3 Field Strength of Spurious Radiation Measurement 24

4 LIST OF MEASURING EQUIPMENTS..... 40

5 UNCERTAINTY OF EVALUATION..... 41

APPENDIX A. PHOTOGRAPHS OF EUT

APPENDIX B. SETUP PHOTOGRAPHS



SUMMARY OF TEST RESULT

Report Section	FCC Rule	Description	Limit	Result	Remark
3.1	§2.1046	Conducted Output Power	Reporting Only	PASS	-
3.1	§22.913(a)(2)	Effective Radiated Power	< 7 Watts	PASS	-
3.1	§24.232(c)	Equivalent Isotropic Radiated Power	< 2 Watts	PASS	-
3.1	§27.50(d)(4)	Equivalent Isotropic Radiated Power	< 1 Watts	PASS	-
3.2	§24.232(d) §27.50(d)(5)	Peak-to-Average Ratio	< 13 dB	PASS	-
3.3	§2.1053 §22.917(a) §24.238(a) §27.53(g)	Field Strength of Spurious Radiation	< 43+10log10(P[Watts])	PASS	Under limit 7.73 dB at 5640.000 MHz



1 General Description

1.1 Applicant

PEGATRON CORPORATION

No. 76, Ligong St., Beitou District, Taipei City 112

1.2 Manufacturer

Huawei Technologies Canada Co., Ltd.

Administration Building, Headquarters of Huawei Technologies Co., Ltd., Bantian, Longgang District, Shenzhen, 518129, P.R.C.

1.3 Feature of Equipment Under Test

Product Feature	
Equipment	HSPA+ Module
Brand Name	HUAWEI
Model Name	MU736
FCC ID	VUIMU736ARC1
EUT supports Radios application	GSM/EGPRS/WCDMA/HSPA
EUT Stage	Production Unit

Remark: The above EUT's information was declared by manufacturer. Please refer to the specifications or user's manual for more detailed description.

1.4 Product Specification of Equipment Under Test

Product Specification subjective to this standard	
Tx Frequency	GSM850: 824.2 MHz ~ 848.8 MHz GSM1900: 1850.2 MHz ~ 1909.8MHz WCDMA Band V: 826.4 MHz ~ 846.6 MHz WCDMA Band IV : 1712.4 MHz ~ 1752.6 MHz WCDMA Band II: 1852.4 MHz ~ 1907.6 MHz
Rx Frequency	GSM850: 869.2 MHz ~ 893.8 MHz GSM1900: 1930.2 MHz ~ 1989.8 MHz WCDMA Band V: 871.4 MHz ~ 891.6 MHz WCDMA Band IV : 2112.4 MHz ~ 2152.6 MHz WCDMA Band II : 1932.4 MHz ~ 1987.6 MHz
Maximum Output Power to Antenna	GSM850 : 31.68 dBm GSM1900 : 28.68 dBm WCDMA Band V : 23.33 dBm WCDMA Band IV : 23.12 dBm WCDMA Band II : 23.13 dBm
Antenna Type	PCB Antenna
Antenna Gain	GSM850 : 2.69 dBi GSM1900 : 3.33 dBi WCDMA Band V : 2.69 dBi WCDMA Band IV : 2.30 dBi WCDMA Band II : 3.33dBi
Type of Modulation	GSM: GMSK GPRS: GMSK EDGE: GMSK / 8PSK WCDMA: QPSK (Uplink) HSDPA: QPSK (Uplink) HSUPA: QPSK (Uplink)



1.5 Maximum ERP/EIRP Power

FCC Rule	System	Type of Modulation	Maximum ERP/EIRP (W)
Part 22	GSM850 GPRS class 8	GMSK	1.6672
Part 22	GSM850 EDGE class 8	8PSK	0.4732
Part 22	WCDMA Band V RMC 12.2Kbps	QPSK	0.2438
Part 24	GSM1900 GPRS class 8	GMSK	1.5885
Part 24	GSM1900 EDGE class 8	8PSK	0.6855
Part 24	WCDMA Band II RMC 12.2Kbps	QPSK	0.4426
Part 27	WCDMA Band IV RMC 12.2Kbps	QPSK	0.3483



1.6 Testing Site

Test Site	SPORTON INTERNATIONAL INC.		
Test Site Location	No. 52, Hwa Ya 1 st Rd., Hwa Ya Technology Park, Kwei-Shan Hsiang, Tao Yuan Hsien, Taiwan, R.O.C. TEL: +886-3-327-3456 FAX: +886-3-328-4978		
Test Site No.	Sporton Site No.		FCC/IC Registration No.
	TH02-HY	03CH08-HY	636805/4086B-2

1.7 Applied Standards

According to the specifications of the manufacturer, the EUT must comply with the requirements of the following standards:

- ♦ 47 CFR Part 2, 22(H), 24(E), 27(L)
- ♦ ANSI / TIA / EIA-603-C-2004
- ♦ FCC KDB 412172 D01 Determining ERP and ERIP v01

Remark:

1. All test items were verified and recorded according to the standards and without any deviation during the test.
2. This EUT has also been tested and complied with the requirements of FCC Part 15, Subpart B, recorded in a separate test report.

2 Test Configuration of Equipment Under Test

2.1 Test Mode

During all testing, EUT is in link mode with base station emulator at maximum power level. The spurious emission measurements were carried out in semi-anechoic chamber with 3-meter test range, and EUT is rotated on three test planes to find out the worst emission.

Frequency range investigated for radiated emission is as follows:

1. 30 MHz to 9000 MHz for GSM850 and WCDMA Band V.
2. 30 MHz to 18000 MHz for WCDMA Band IV.
3. 30 MHz to 19000 MHz for GSM1900 and WCDMA Band II.

Test Modes		
Band	Radiated TCs	Conducted TCs
GSM 850	<ul style="list-style-type: none"> ■ GPRS class 8 Link ■ EDGE class 8 Link 	<ul style="list-style-type: none"> ■ GPRS class 8 Link ■ EDGE class 8 Link
GSM 1900	<ul style="list-style-type: none"> ■ GPRS class 8 Link ■ EDGE class 8 Link 	<ul style="list-style-type: none"> ■ GPRS class 8 Link ■ EDGE class 8 Link
WCDMA Band V	<ul style="list-style-type: none"> ■ RMC 12.2Kbps Link 	<ul style="list-style-type: none"> ■ RMC 12.2Kbps Link
WCDMA Band IV	<ul style="list-style-type: none"> ■ RMC 12.2Kbps Link 	<ul style="list-style-type: none"> ■ RMC 12.2Kbps Link
WCDMA Band II	<ul style="list-style-type: none"> ■ RMC 12.2Kbps Link 	<ul style="list-style-type: none"> ■ RMC 12.2Kbps Link

Note: The maximum power levels are GPRS multi-slot class 8 mode for GMSK link, EDGE multi-slot class 8 mode for 8PSK link, RMC 12.2Kbps mode for WCDMA band V, RMC 12.2Kbps mode for WCDMA band IV, and RMC 12.2Kbps mode for WCDMA band II, only these modes were used for all tests.



The conducted power tables are as follows:

Conducted Power (*Unit: dBm)						
Band	GSM850			GSM1900		
Channel	128	189	251	512	661	810
Frequency	824.2	836.4	848.8	1850.2	1880	1909.8
GPRS class 8	31.52	31.58	31.68	28.68	28.59	28.54
GPRS class 10	29.24	29.29	29.37	26.18	26.10	26.06
GPRS class 11	27.69	27.79	27.89	24.67	24.59	24.55
GPRS class 12	26.60	26.66	26.73	23.48	23.39	23.35
EGPRS class 8	26.06	26.11	26.21	25.03	25.02	25.00
EGPRS class 10	23.53	23.60	23.68	22.61	22.51	22.50
EGPRS class 11	22.06	22.13	22.21	21.16	21.07	21.00
EGPRS class 12	20.58	20.63	20.73	19.66	19.57	19.51

Conducted Power (*Unit: dBm)									
Band	WCDMA Band V			WCDMA Band II			WCDMA Band IV		
Tx Channel	4132	4182	4233	9262	9400	9538	1312	1413	1513
Rx Channel	4357	4407	4458	9662	9800	9938	1537	1638	1738
Frequency	826.4	836.4	846.6	1852.4	1880	1907.6	1712.4	1732.6	1752.6
RMC 12.2K	23.33	23.09	22.88	23.00	23.13	22.85	23.12	22.93	22.88
HSDPA Subtest-1	23.10	22.92	22.72	22.63	22.88	22.60	22.89	22.66	22.57
HSDPA Subtest-2	22.15	21.86	21.69	21.63	21.80	21.62	21.91	21.78	21.79
HSDPA Subtest-3	21.88	21.60	21.40	21.46	21.55	21.42	21.64	21.44	21.41
HSDPA Subtest-4	21.68	21.31	21.17	21.21	21.33	21.18	21.40	21.19	21.16
HSUPA Subtest-1	22.15	21.87	21.65	21.83	21.89	21.71	21.93	21.81	21.70
HSUPA Subtest-2	20.13	19.71	19.82	19.72	20.04	19.55	20.05	19.84	19.81
HSUPA Subtest-3	20.92	20.68	20.51	20.55	20.74	20.58	20.72	20.61	20.59
HSUPA Subtest-4	20.49	20.23	20.19	19.83	19.90	19.79	20.11	19.66	19.68
HSUPA Subtest-5	22.11	21.74	21.54	21.60	21.78	21.65	21.81	21.84	21.85

2.2 Connection Diagram of Test System

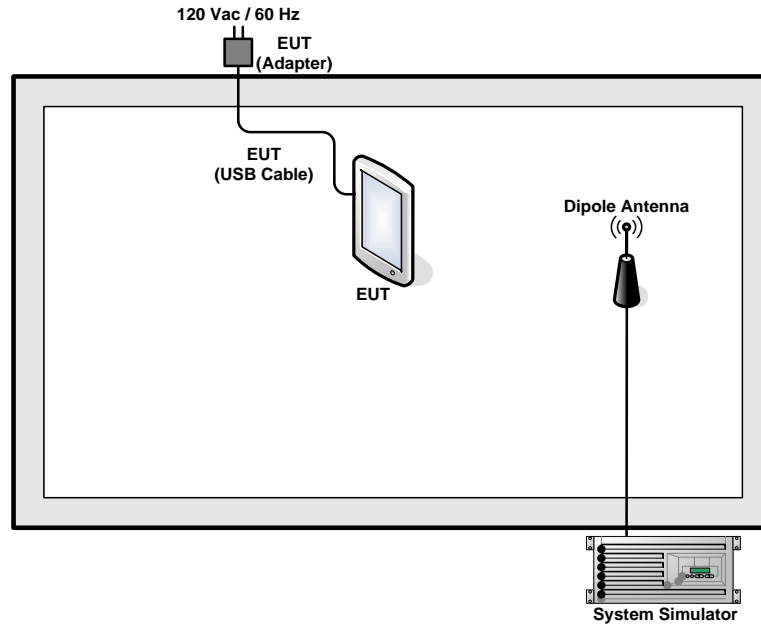

2.3 Support Unit used in test configuration and system

Item	Equipment	Trade Name	Model No.	FCC ID	Data Cable	Power Cord
1.	System Simulator	R&S	CMU 200	N/A	N/A	Unshielded, 1.8 m



2.4 Measurement Results Explanation Example

For all conducted test items:

The offset level is set in the spectrum analyzer to compensate the RF cable loss and attenuator factor between EUT conducted output port and spectrum analyzer. With the offset compensation, the spectrum analyzer reading level is exactly the EUT RF output level.

The spectrum analyzer offset is derived from RF cable loss and attenuator factor.

Offset = RF cable loss + attenuator factor.

Following shows an offset computation example with cable loss 4.2 dB and 10dB attenuator.

Example :

$$\begin{aligned} \text{Offset(dB)} &= \text{RF cable loss(dB)} + \text{attenuator factor(dB)}. \\ &= 4.2 + 10 = 14.2 \text{ (dB)} \end{aligned}$$

3 Test Result

3.1 Conducted Output Power Measurement and ERP/EIRP Measurement

3.1.1 Description of the Conducted Output Power and ERP/EIRP Measurement

A base station simulator was used to establish communication with the EUT. Its parameters were set to transmit the maximum power on the EUT. The measured power in the radio frequency on the transmitter output terminals shall be reported.

The ERP of mobile transmitters must not exceed 7 Watts and the EIRP of mobile transmitters are limited to 2 Watts. According to KDB 412172 D01 Power Approach,

$EIRP = P_T + G_T - L_C$, $ERP = EIRP - 2.15$, where

P_T = transmitter output power in dBm

G_T = gain of the transmitting antenna in dBi

L_C = signal attenuation in the connecting cable between the transmitter and antenna in dB

3.1.2 Measuring Instruments

See list of measuring instruments of this test report.

3.1.3 Test Procedures

1. The transmitter output port was connected to base station.
2. The RF output of EUT was connected to the spectrum analyzer by RF cable and attenuator. The path loss was compensated to the results for each measurement.
3. Set EUT at maximum power through base station.
4. Select lowest, middle, and highest channels for each band and different modulation.
5. Measure the maximum burst average power for GSM and maximum average power for GSM and WCDMA modes.
6. The procedure section 2.0 of FCC KDB 412172 is used to determine the Radiated Power Measurement.

3.1.4 Test Setup

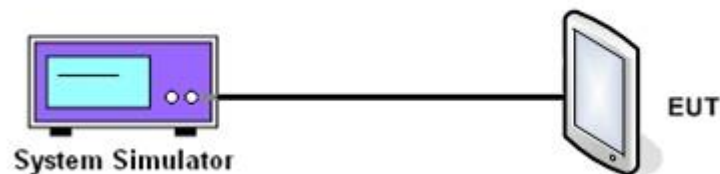

3.1.5 Test Result of Conducted Output Power

Cellular Band ($G_T - L_C = 2.69\text{dB}$)									
Modes	GSM850 (GPRS class 8)			GSM850 (EDGE class 8)			WCDMA Band V (RMC 12.2Kbps)		
Channel	128 (Low)	189 (Mid)	251 (High)	128 (Low)	189 (Mid)	251 (High)	4132 (Low)	4182 (Mid)	4233 (High)
Frequency (MHz)	824.2	836.4	848.8	824.2	836.4	848.8	826.4	836.4	846.6
Conducted Power (dBm)	31.52	31.58	31.68	26.06	26.11	26.21	23.33	23.09	22.88
Conducted Power (Watts)	1.4191	1.4388	1.4723	0.4036	0.4083	0.4178	0.2153	0.2037	0.1941
ERP(dBm)	32.06	32.12	32.22	26.60	26.65	26.75	23.87	23.63	23.42
ERP(Watts)	1.6069	1.6293	1.6672	0.4571	0.4624	0.4732	0.2438	0.2307	0.2198

PCS Band ($G_T - L_C = 3.33\text{dB}$)									
Modes	GSM1900 (GPRS class 8)			GSM1900 (EDGE class 8)			WCDMA Band II (RMC 12.2Kbps)		
Channel	512 (Low)	661 (Mid)	810 (High)	512 (Low)	661 (Mid)	810 (High)	9262 (Low)	9400 (Mid)	9538 (High)
Frequency (MHz)	1850.2	1880	1909.8	1850.2	1880	1909.8	1852.4	1880	1907.6
Conducted Power (dBm)	28.68	28.59	28.54	25.03	25.02	25.00	23.00	23.13	22.85
Conducted Power (Watts)	0.7379	0.7228	0.7145	0.3184	0.3177	0.3162	0.1995	0.2056	0.1928
EIRP(dBm)	32.01	31.92	31.87	28.36	28.35	28.33	26.33	26.46	26.18
EIRP(Watts)	1.5885	1.5560	1.5382	0.6855	0.6839	0.6808	0.4295	0.4426	0.4150



AWS Band ($G_T - L_C = 2.30\text{dB}$)			
Modes	WCDMA Band IV (RMC 12.2Kbps)		
Channel	1312(Low)	1413 (Mid)	1513 (High)
Frequency (MHz)	1712.4	1732.6	1752.6
Conducted Power (dBm)	23.12	22.93	22.88
Conducted Power (Watts)	0.2051	0.1963	0.1941
EIRP(dBm)	25.42	25.23	25.18
EIRP(Watts)	0.3483	0.3334	0.3296

Note: maximum burst average power for GSM, and maximum average power for WCDMA.

$EIRP = P_T + G_T - L_C$, $ERP = EIRP - 2.15$, where

P_T = transmitter output power in dBm

G_T = gain of the transmitting antenna in dBi

L_C = signal attenuation in the connecting cable between the transmitter and antenna in dB

3.2 Peak-to-Average Ratio

3.2.1 Description of the PAR Measurement

The peak-to-average ratio (PAR) of the transmission may not exceed 13 dB.

3.2.2 Measuring Instruments

See list of measuring instruments of this test report.

3.2.3 Test Procedures

1. The EUT was connected to Spectrum Analyzer and System Simulator via power divider.
2. For GSM/EGPRS operating modes:
 - a. Set EUT in maximum power output.
 - b. Set the RBW = 1MHz, VBW = 3MHz, Peak detector in spectrum analyzer for first trace.
 - c. Set the RBW = 1MHz, VBW = 3MHz, RMS detector in spectrum analyzer for second trace.
 - d. The wanted burst signal is triggered by spectrum analyzer, and measured respectively the peak level and Mean level without burst-off time, after system simulator synchronized with the spectrum analyzer.
3. For UMTS operating modes:
 - a. Set the CCDF (Complementary Cumulative Distribution Function) option in spectrum analyzer.
 - b. The highest RF powers were measured and recorded the maximum PAPR level associated with a probability of 0.1 %.
4. Record the deviation as Peak to Average Ratio.

3.2.4 Test Setup

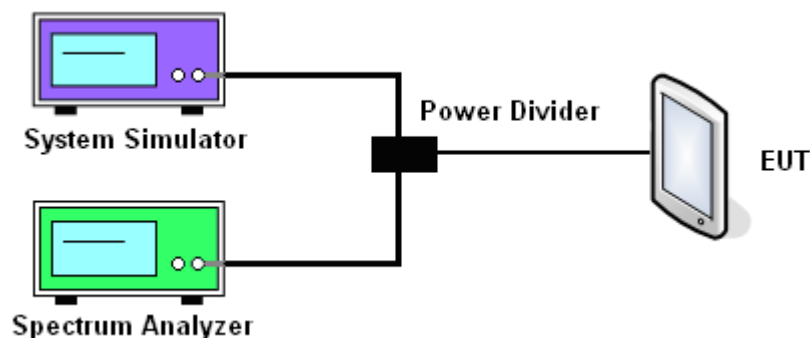



3.2.5 Test Result of Peak-to-Average Ratio

Cellular Band									
Modes	GSM850 (GPRS class 8)			GSM850 (EDGE class 8)			WCDMA Band V (RMC 12.2Kbps)		
Channel	128 (Low)	189 (Mid)	251 (High)	128 (Low)	189 (Mid)	251 (High)	4132 (Low)	4182 (Mid)	4233 (High)
Frequency (MHz)	824.2	836.4	848.8	824.2	836.4	848.8	826.4	836.4	846.6
Peak-to-Average Ratio (dB)	0.36	0.34	0.33	2.75	2.76	2.70	3.16	2.96	2.96



3.2.6 Test Result (Plots) of Peak-to-Average Ratio

Band :	GSM 850	Test Mode :	GPRS class 8 Link (GMSK)
--------	---------	-------------	--------------------------

Peak-to-Average Ratio on Channel 128 (824.2 MHz)

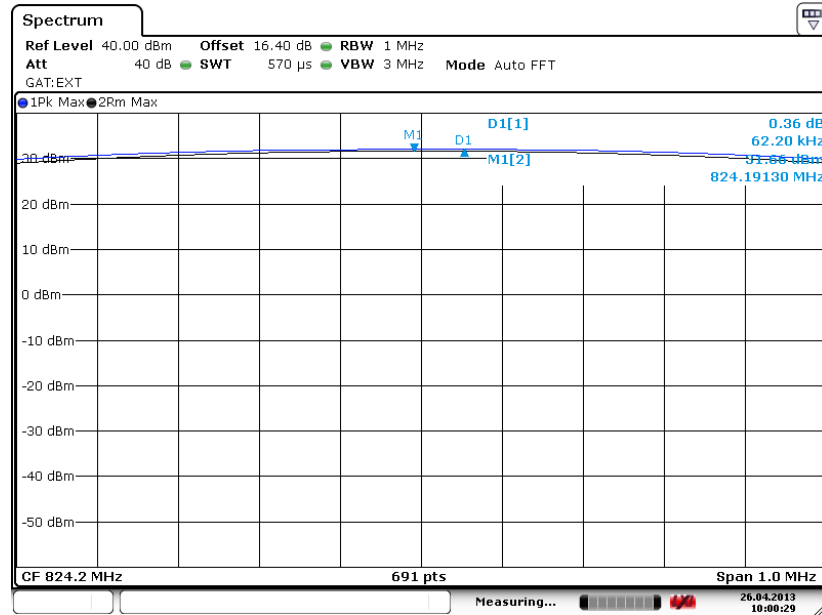

Date: 26.APR.2013 10:00:29

Peak-to-Average Ratio on Channel 189 (836.4 MHz)

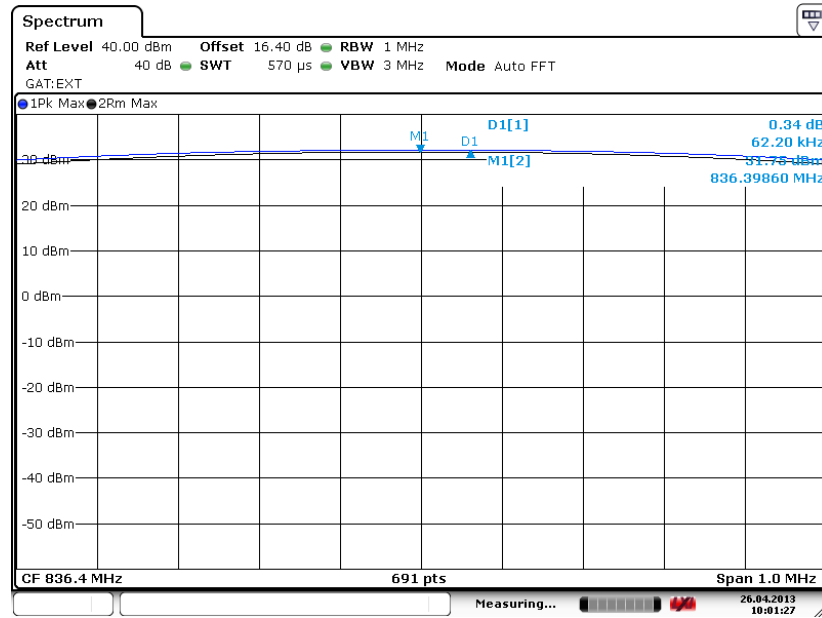

Date: 26.APR.2013 10:01:27



Peak-to-Average Ratio on Channel 251 (848.8 MHz)

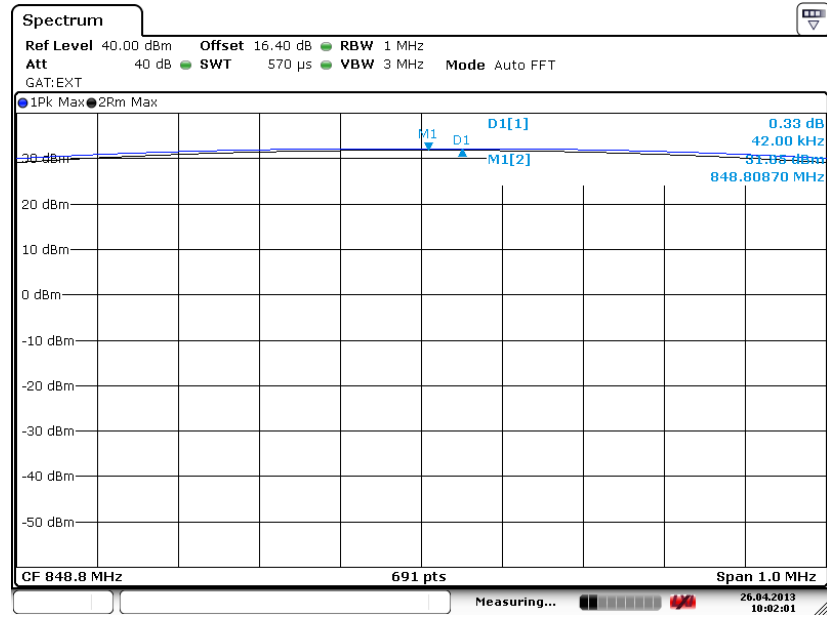

Date: 26.APR.2013 10:02:01



Band :	GSM 850	Test Mode :	EDGE class 8 Link (8PSK)
---------------	---------	--------------------	--------------------------

Peak-to-Average Ratio on Channel 128 (824.2 MHz)

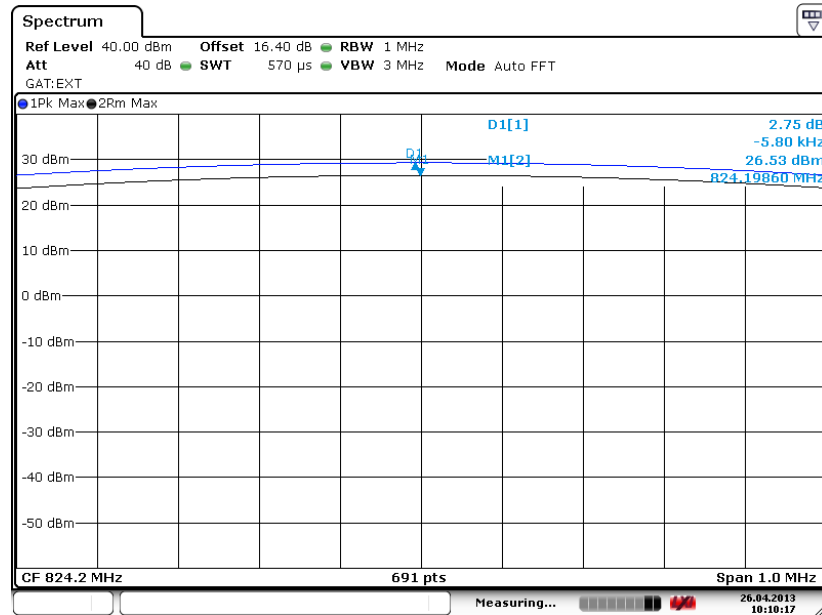

Date: 26.APR.2013 10:10:18

Peak-to-Average Ratio on Channel 189 (836.4 MHz)

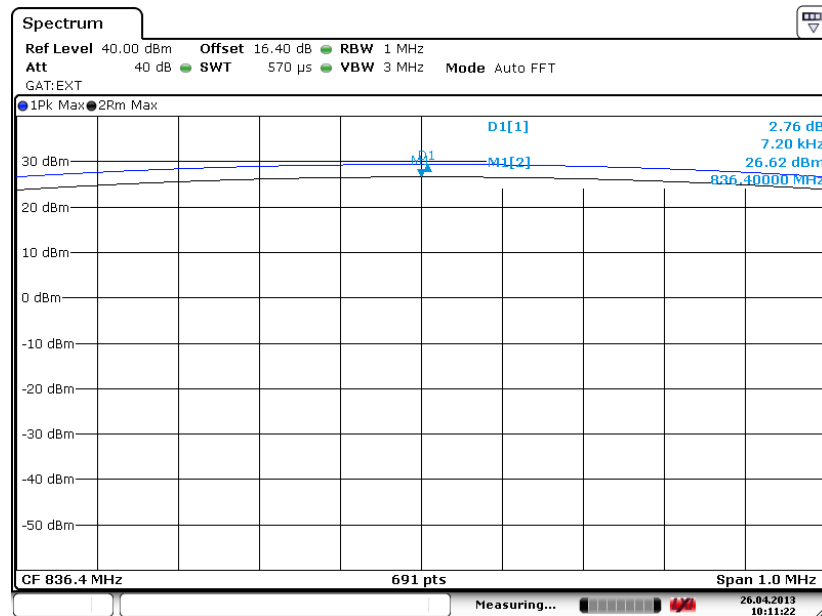

Date: 26.APR.2013 10:11:22



Peak-to-Average Ratio on Channel 251 (848.8 MHz)

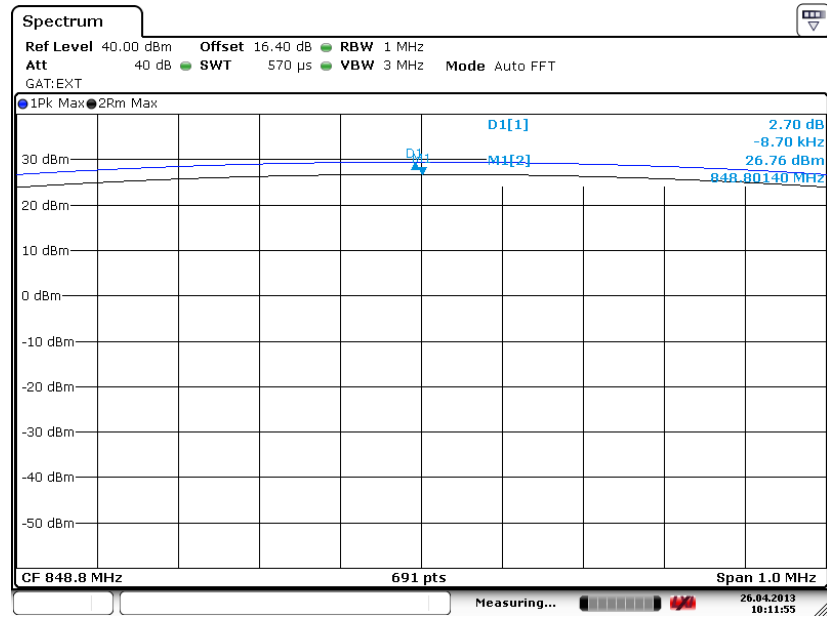

Date: 26.APR.2013 10:11:56



Band :	WCDMA Band V	Test Mode :	RMC 12.2Kbps Link (QPSK)
---------------	--------------	--------------------	--------------------------

Peak-to-Average Ratio on Channel 4132 (826.4 MHz)

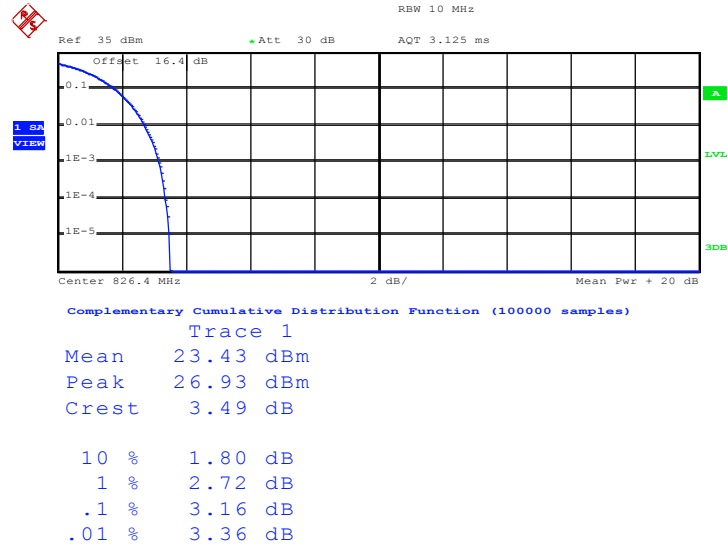

Date: 25.APR.2013 18:32:29

Peak-to-Average Ratio on Channel 4182 (836.4 MHz)

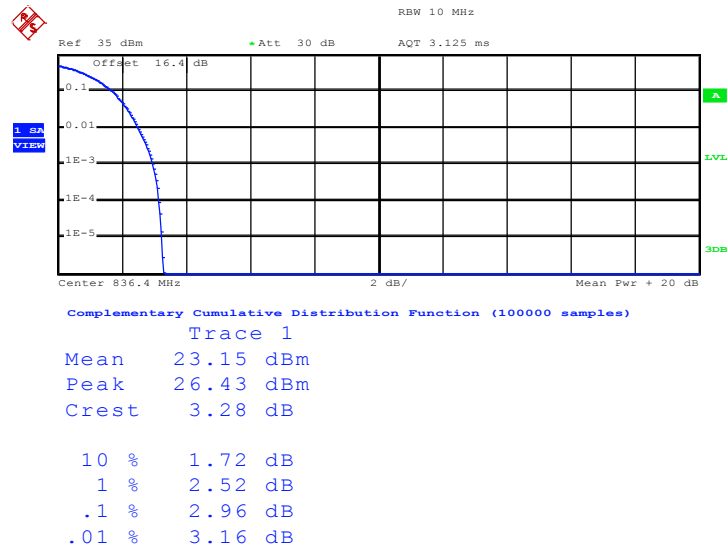

Date: 25.APR.2013 18:33:06



Peak-to-Average Ratio on Channel 4233 (846.6 MHz)

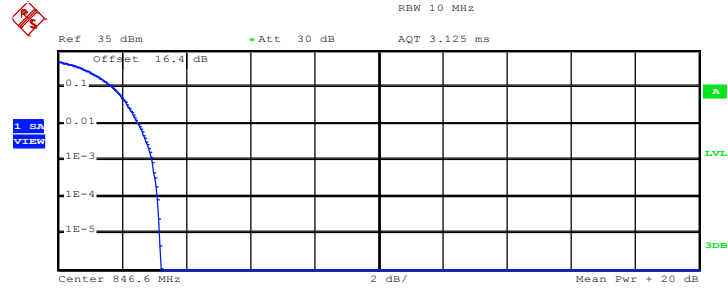

Complementary Cumulative Distribution Function (100000 samples)

Trace 1	
Mean	23.16 dBm
Peak	26.36 dBm
Crest	3.20 dB
10 %	1.72 dB
1 %	2.52 dB
.1 %	2.96 dB
.01 %	3.12 dB

Date: 25.APR.2013 18:33:55



3.3 Field Strength of Spurious Radiation Measurement

3.3.1 Description of Field Strength of Spurious Radiated Measurement

The power of any emission outside of the authorized operating frequency ranges must be attenuated below the transmitter power (P) by a factor of at least $43 + 10 \log(P)$ dB. The spectrum is scanned from 30 MHz up to a frequency including its 10th harmonic.

3.3.2 Measuring Instruments

See list of measuring instruments of this test report.

3.3.3 Test Procedures

1. The EUT was placed on a rotatable wooden table with 0.8 meter above ground.
2. The EUT was set 3 meters from the receiving antenna, which was mounted on the antenna tower.
3. The table was rotated 360 degrees to determine the position of the highest spurious emission.
4. The height of the receiving antenna is varied between one meter and four meters to search the maximum spurious emission for both horizontal and vertical polarizations.
5. Make the measurement with the spectrum analyzer's RBW = 1MHz, VBW = 3MHz, taking the record of maximum spurious emission.
6. A horn antenna was substituted in place of the EUT and was driven by a signal generator.
7. Tune the output power of signal generator to the same emission level with EUT maximum spurious emission.
8. Taking the record of output power at antenna port.
9. Repeat step 7 to step 8 for another polarization.
10. The RF fundamental frequency should be excluded against the limit line in the operating frequency band.
11. The limit line is derived from $43 + 10\log(P)$ dB below the transmitter power P(Watts)
= $P(W) - [43 + 10\log(P)]$ (dB)
= $[30 + 10\log(P)]$ (dBm) - $[43 + 10\log(P)]$ (dB)
= -13dBm.
12. $EIRP$ (dBm) = S.G. Power – Tx Cable Loss + Tx Antenna Gain
13. ERP (dBm) = $EIRP - 2.15$

3.3.4 Test Setup

For radiated emissions from 30MHz to 1GHz

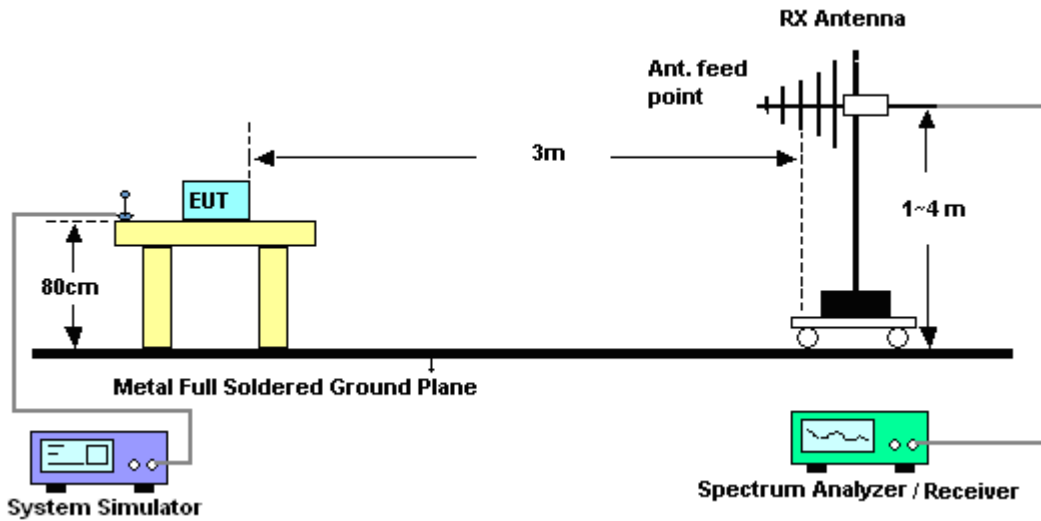

For radiated emissions above 1GHz

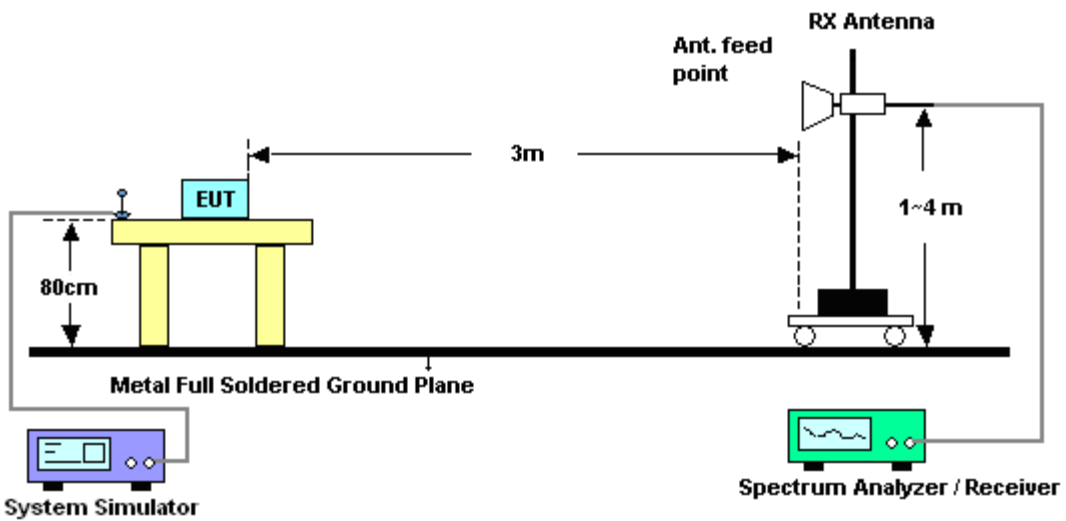



3.3.5 Test Result of Field Strength of Spurious Radiated

Band :	GSM850	Temperature :	24~25°C
Test Mode :	GPRS class 8 Link (GMSK)	Relative Humidity :	42~43%
Test Engineer :	Elvis Chen and David Yang	Polarization :	Horizontal
Remark :	Spurious emissions within 30-1000MHz were found more than 20dB below limit line.		

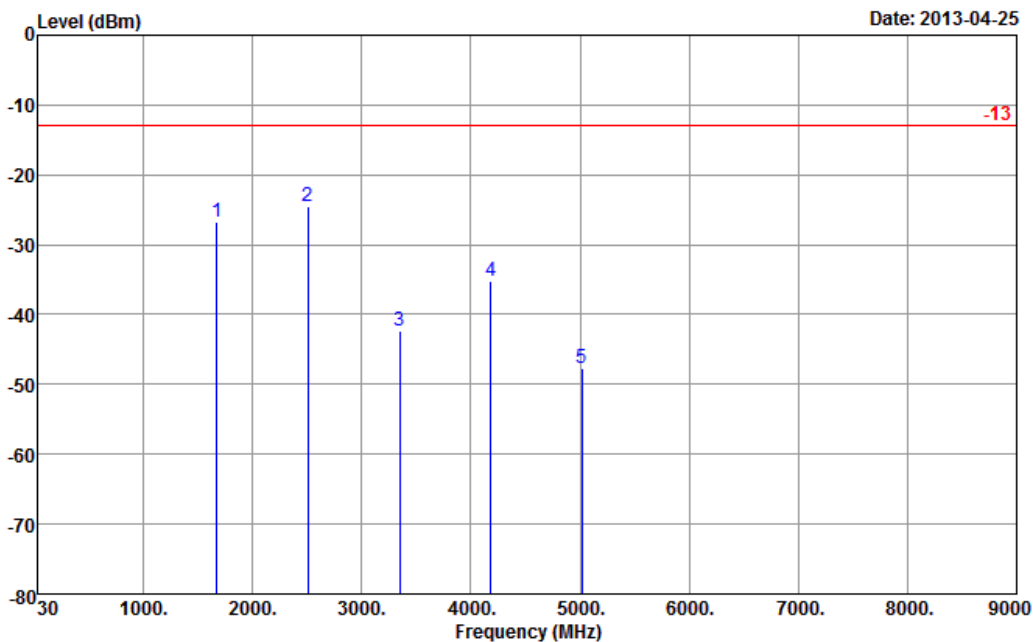

Site : 03CH08-HY
 Condition : -13 EIRP_130315 HORIZONTAL
 Project : FG 322823-02

Frequency (MHz)	ERP (dBm)	Limit (dBm)	Over Limit (dB)	SPA Reading (dBm)	S.G. Power (dBm)	TX Cable loss (dB)	TX Antenna Gain (dBi)	Polarization (H/V)	Result
1672	-26.73	-13	-13.73	-18.44	-28.45	1.62	5.49	H	Pass
2509	-24.62	-13	-11.62	-18.55	-26.59	2.1	6.22	H	Pass
3346	-42.32	-13	-29.32	-36.3	-45.21	3.03	8.07	H	Pass
4180	-35.30	-13	-22.30	-32.5	-39.84	2.52	9.21	H	Pass
5020	-47.73	-13	-34.73	-43.31	-53.18	3.1	10.70	H	Pass



Band :	GSM850	Temperature :	24~25°C
Test Mode :	GPRS class 8 Link (GMSK)	Relative Humidity :	42~43%
Test Engineer :	Elvis Chen and David Yang	Polarization :	Vertical
Remark :	Spurious emissions within 30-1000MHz were found more than 20dB below limit line.		

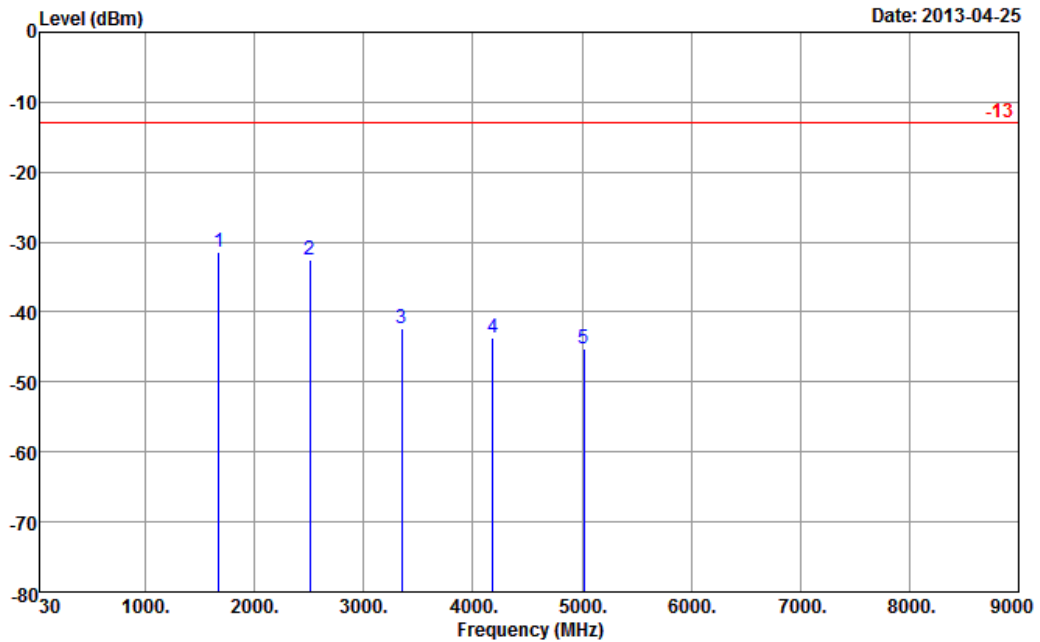

Site : 03CH08-HY
 Condition : -13 EIRP_130315 VERTICAL
 Project : FG 322823-02

Frequency (MHz)	ERP (dBm)	Limit (dBm)	Over Limit (dB)	SPA Reading (dBm)	S.G. Power (dBm)	TX Cable loss (dB)	TX Antenna Gain (dBi)	Polarization (H/V)	Result
1672	-31.40	-13	-18.40	-21.79	-33.12	1.62	5.49	V	Pass
2509	-32.59	-13	-19.59	-24.53	-34.56	2.1	6.22	V	Pass
3346	-42.30	-13	-29.30	-36.24	-45.19	3.03	8.07	V	Pass
4180	-43.62	-13	-30.62	-40.37	-48.16	2.52	9.21	V	Pass
5020	-45.33	-13	-32.33	-44.01	-50.78	3.1	10.70	V	Pass



Band :	GSM850	Temperature :	24~25°C
Test Mode :	EDGE class 8 Link (8PSK)	Relative Humidity :	42~43%
Test Engineer :	Elvis Chen and David Yang	Polarization :	Horizontal
Remark :	Spurious emissions within 30-1000MHz were found more than 20dB below limit line.		

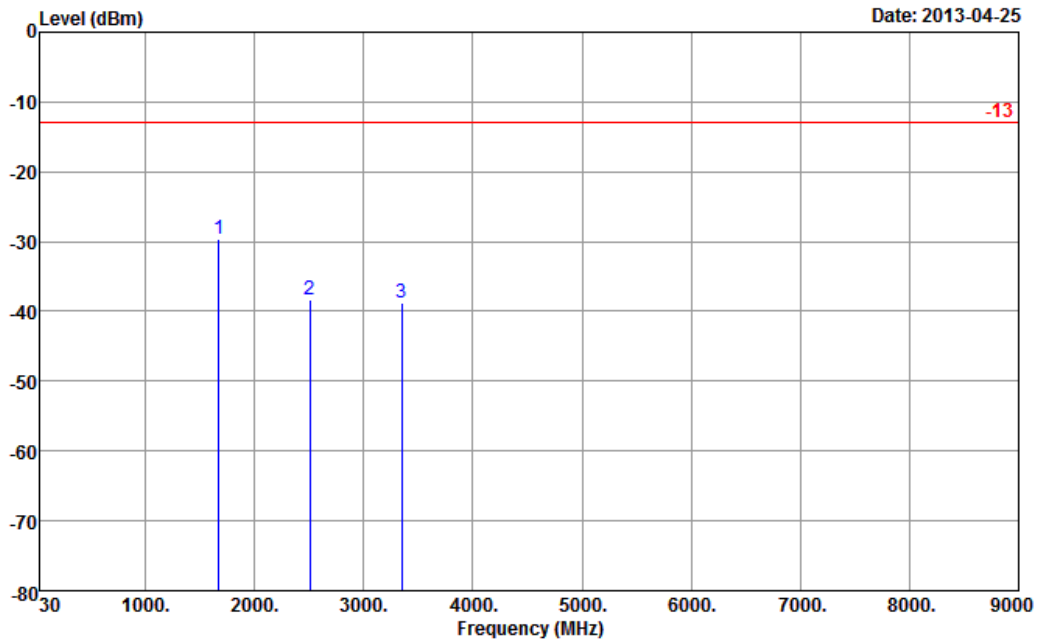

Site : 03CH08-HY
 Condition : -13 EIRP_130315 HORIZONTAL
 Project : FG 322823-02

Frequency (MHz)	ERP (dBm)	Limit (dBm)	Over Limit (dB)	SPA Reading (dBm)	S.G. Power (dBm)	TX Cable loss (dB)	TX Antenna Gain (dBi)	Polarization (H/V)	Result
1672	-29.74	-13	-16.74	-21.1	-31.46	1.62	5.49	H	Pass
2509	-38.31	-13	-25.31	-32.8	-40.28	2.1	6.22	H	Pass
3346	-38.77	-13	-25.77	-32.65	-41.66	3.03	8.07	H	Pass



Band :	GSM850	Temperature :	24~25°C
Test Mode :	EDGE class 8 Link (8PSK)	Relative Humidity :	42~43%
Test Engineer :	Elvis Chen and David Yang	Polarization :	Vertical
Remark :	Spurious emissions within 30-1000MHz were found more than 20dB below limit line.		

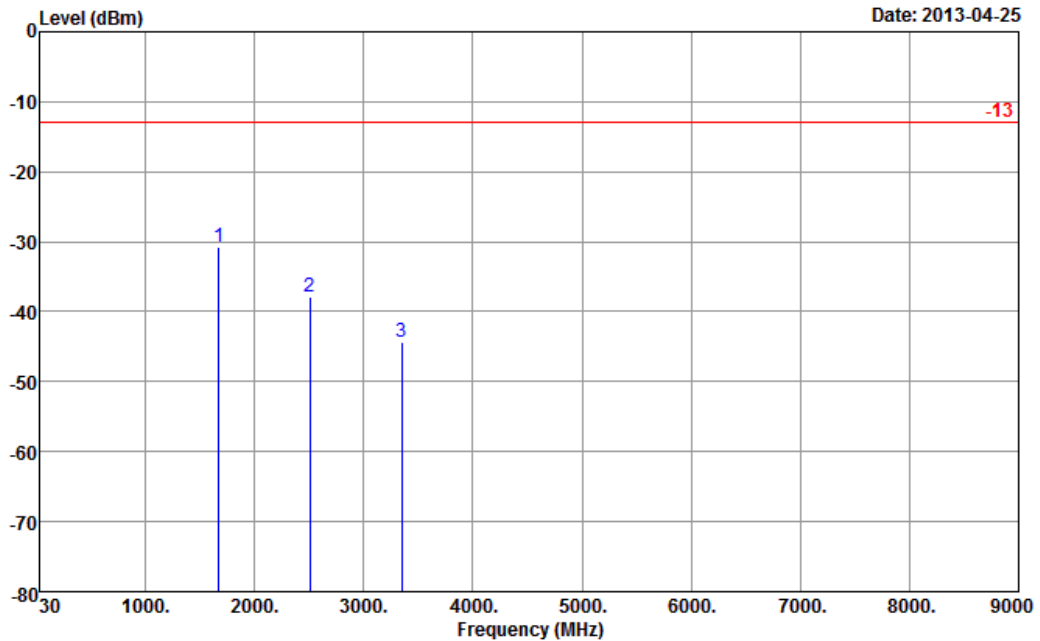

Site : 03CH08-HY
 Condition : -13 EIRP_130315 VERTICAL
 Project : FG 322823-02

Frequency (MHz)	ERP (dBm)	Limit (dBm)	Over Limit (dB)	SPA Reading (dBm)	S.G. Power (dBm)	TX Cable loss (dB)	TX Antenna Gain (dBi)	Polarization (H/V)	Result
1672	-30.84	-13	-17.84	-20	-32.56	1.62	5.49	V	Pass
2509	-37.89	-13	-24.89	-29.98	-39.86	2.1	6.22	V	Pass
3346	-44.33	-13	-31.33	-38.16	-47.22	3.03	8.07	V	Pass



Band :	GSM1900	Temperature :	24~25°C
Test Mode :	GPRS class 8 Link (GMSK)	Relative Humidity :	42~43%
Test Engineer :	Elvis Chen and David Yang	Polarization :	Horizontal
Remark :	Spurious emissions within 30-1000MHz were found more than 20dB below limit line.		

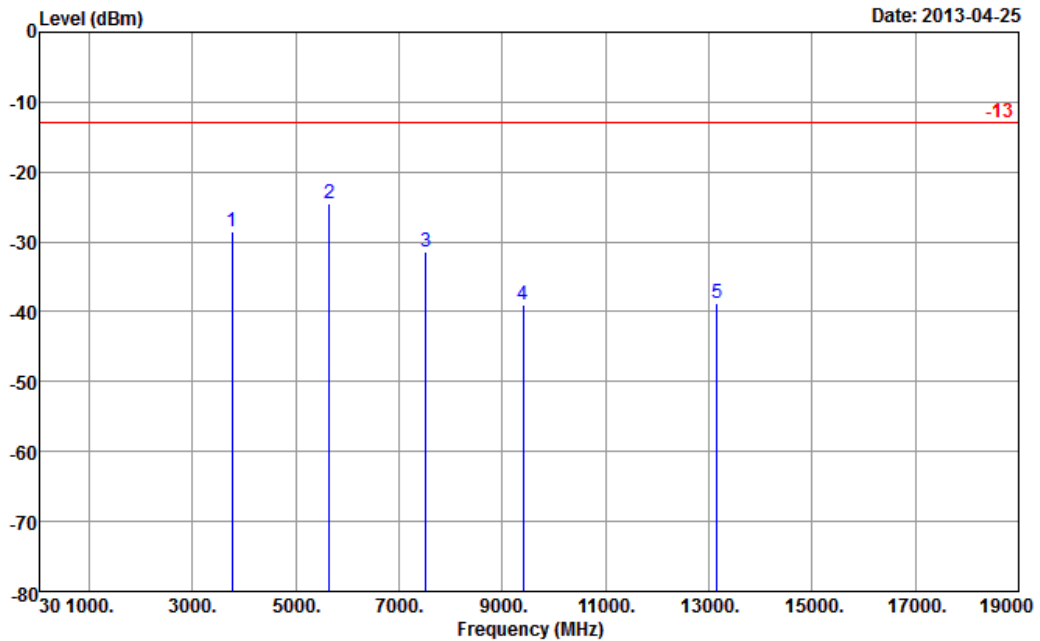

Site : 03CH08-HY
 Condition : -13 EIRP_130315 HORIZONTAL
 Project : FG 322823-02

Frequency (MHz)	EIRP (dBm)	Limit (dBm)	Over Limit (dB)	SPA Reading (dBm)	S.G. Power (dBm)	TX Cable loss (dB)	TX Antenna Gain (dBi)	Polarization (H/V)	Result
3760	-28.59	-13	-15.59	-24.23	-34.89	2.51	8.81	H	Pass
5640	-24.48	-13	-11.48	-21.44	-32.19	2.99	10.70	H	Pass
7520	-31.46	-13	-18.46	-33.91	-39.99	3.59	12.12	H	Pass
9400	-39.03	-13	-26.03	-43.73	-48.13	4.1	13.20	H	Pass
13160	-38.78	-13	-25.78	-52	-48.3	4.27	13.79	H	Pass



Band :	GSM1900	Temperature :	24~25°C
Test Mode :	GPRS class 8 Link (GMSK)	Relative Humidity :	42~43%
Test Engineer :	Elvis Chen and David Yang	Polarization :	Vertical
Remark :	Spurious emissions within 30-1000MHz were found more than 20dB below limit line.		

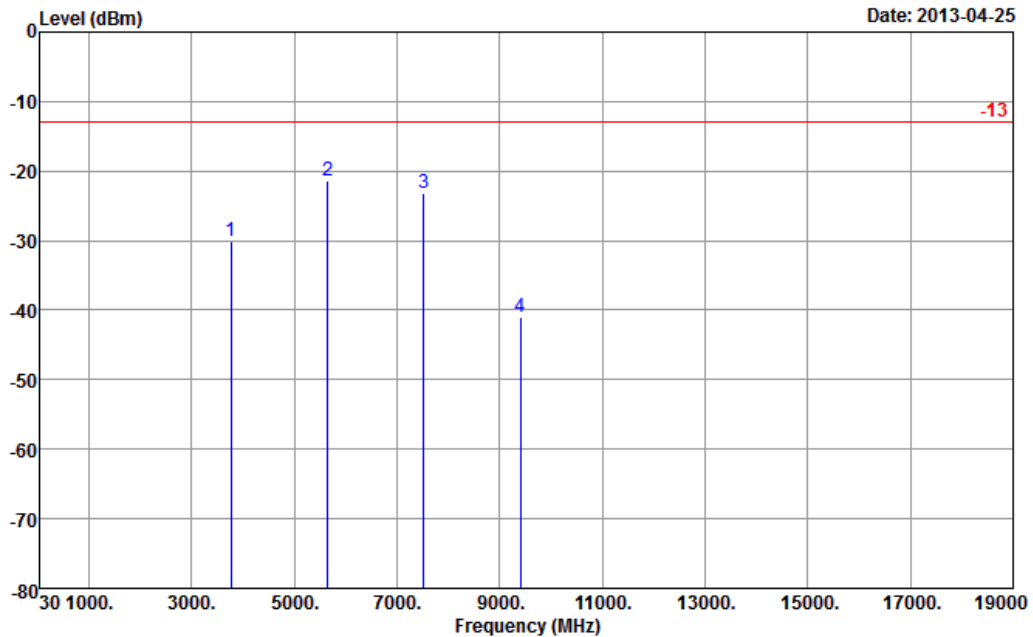

Site : 03CH08-HY
 Condition : -13 EIRP_130315 VERTICAL
 Project : FG 322823-02

Frequency (MHz)	EIRP (dBm)	Limit (dBm)	Over Limit (dB)	SPA Reading (dBm)	S.G. Power (dBm)	TX Cable loss (dB)	TX Antenna Gain (dBi)	Polarization (H/V)	Result
3760	-30.15	-13	-17.15	-25.33	-36.45	2.51	8.81	V	Pass
5640	-21.30	-13	-8.30	-19.69	-29.01	2.99	10.70	V	Pass
7520	-23.14	-13	-10.14	-26.69	-31.67	3.59	12.12	V	Pass
9400	-40.99	-13	-27.99	-45.78	-50.09	4.1	13.20	V	Pass



Band :	GSM1900	Temperature :	24~25°C
Test Mode :	EDGE class 8 Link (8PSK)	Relative Humidity :	42~43%
Test Engineer :	Elvis Chen and David Yang	Polarization :	Horizontal
Remark :	Spurious emissions within 30-1000MHz were found more than 20dB below limit line.		

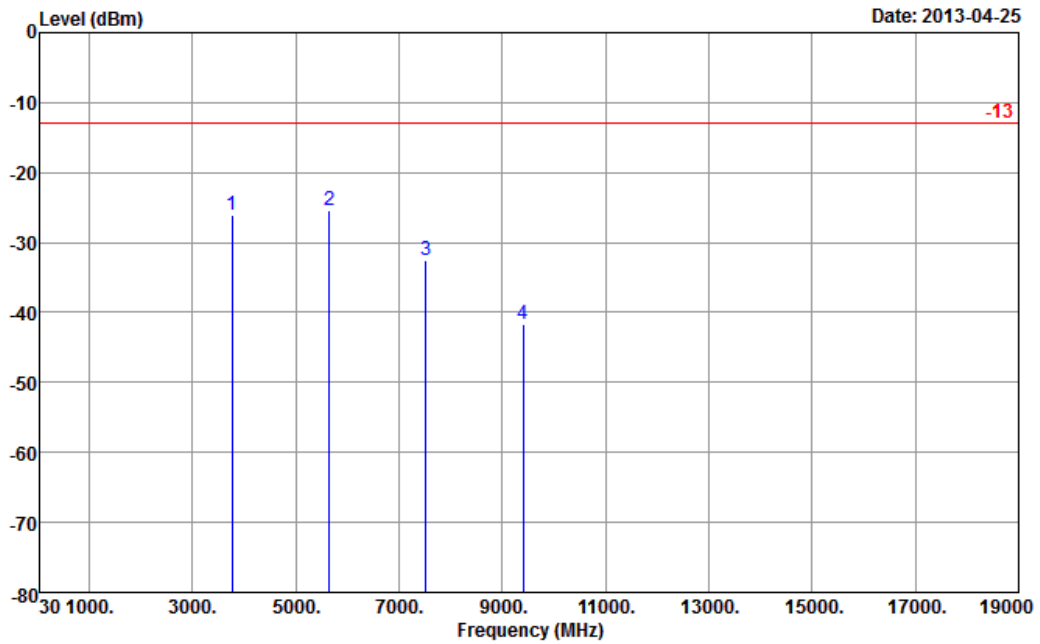

Site : 03CH08-HY
 Condition : -13 EIRP_130315 HORIZONTAL
 Project : FG 322823-02

Frequency (MHz)	EIRP (dBm)	Limit (dBm)	Over Limit (dB)	SPA Reading (dBm)	S.G. Power (dBm)	TX Cable loss (dB)	TX Antenna Gain (dBi)	Polarization (H/V)	Result
3760	-25.97	-13	-12.97	-21.41	-32.27	2.51	8.81	H	Pass
5640	-25.34	-13	-12.34	-22.15	-33.05	2.99	10.70	H	Pass
7520	-32.46	-13	-19.46	-34.77	-40.99	3.59	12.12	H	Pass
9400	-41.58	-13	-28.58	-46.39	-50.68	4.1	13.20	H	Pass



Band :	GSM1900	Temperature :	24~25°C
Test Mode :	EDGE class 8 Link (8PSK)	Relative Humidity :	42~43%
Test Engineer :	Elvis Chen and David Yang	Polarization :	Vertical
Remark :	Spurious emissions within 30-1000MHz were found more than 20dB below limit line.		

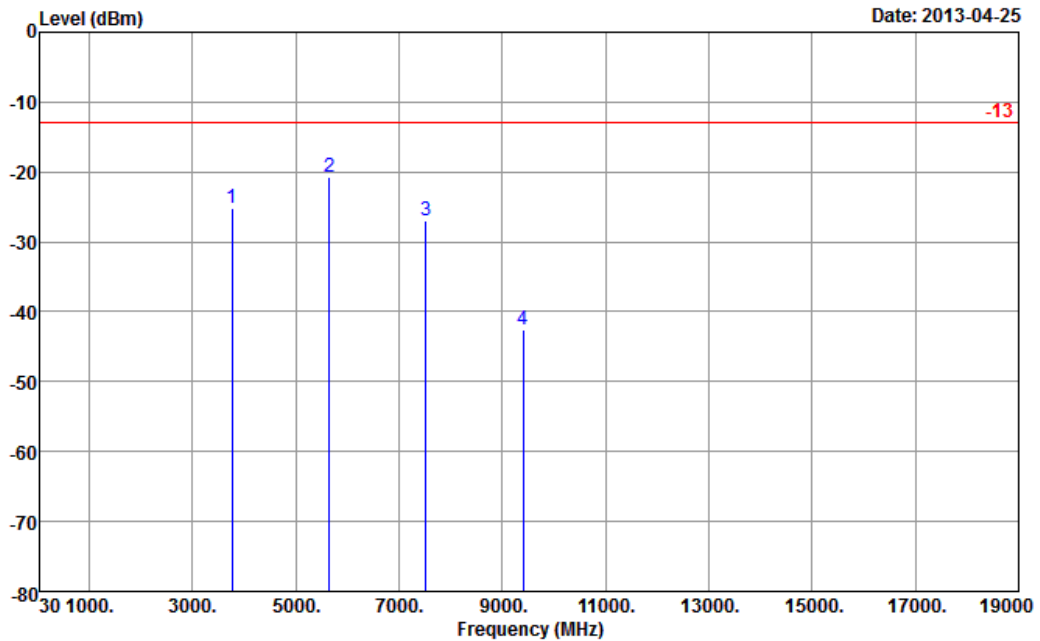

Site : 03CH08-HY
 Condition : -13 EIRP_130315 VERTICAL
 Project : FG 322823-02

Frequency (MHz)	EIRP (dBm)	Limit (dBm)	Over Limit (dB)	SPA Reading (dBm)	S.G. Power (dBm)	TX Cable loss (dB)	TX Antenna Gain (dBi)	Polarization (H/V)	Result
3760	-25.25	-13	-12.25	-20.31	-31.55	2.51	8.81	V	Pass
5640	-20.73	-13	-7.73	-19.1	-28.44	2.99	10.70	V	Pass
7520	-26.87	-13	-13.87	-30.18	-35.4	3.59	12.12	V	Pass
9400	-42.56	-13	-29.56	-47.58	-51.66	4.1	13.20	V	Pass



Band :	WCDMA Band V	Temperature :	24~25°C
Test Mode :	RMC 12.2Kbps Link (QPSK)	Relative Humidity :	42~43%
Test Engineer :	Elvis Chen and David Yang	Polarization :	Horizontal
Remark :	Spurious emissions within 30-1000MHz were found more than 20dB below limit line.		

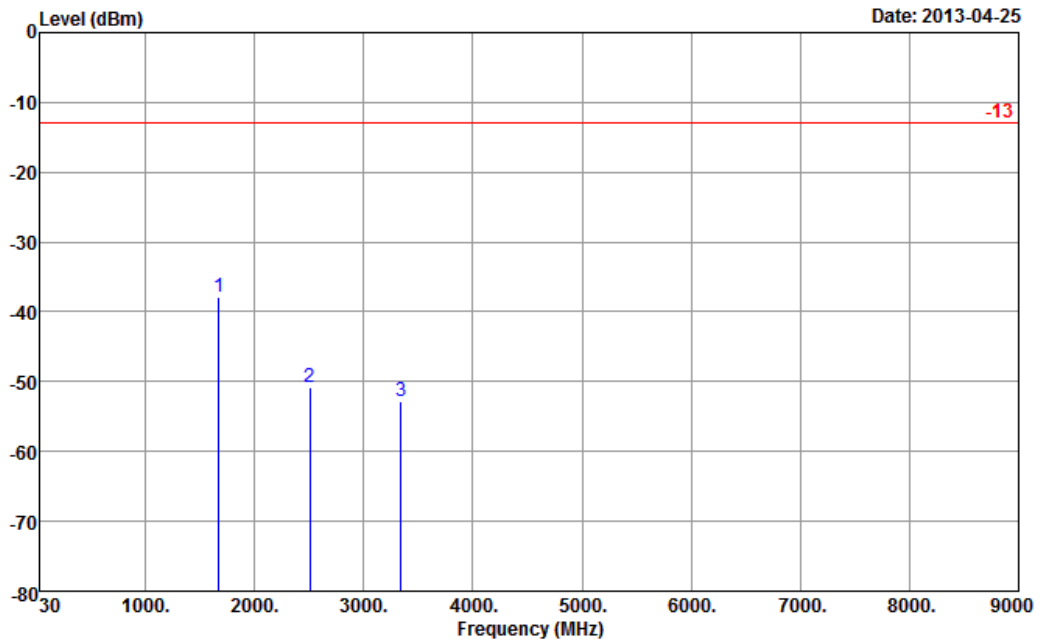

Site : 03CH08-HY
 Condition : -13 EIRP_130315 HORIZONTAL
 Project : FG 322823-02

Frequency (MHz)	ERP (dBm)	Limit (dBm)	Over Limit (dB)	SPA Reading (dBm)	S.G. Power (dBm)	TX Cable loss (dB)	TX Antenna Gain (dBi)	Polarization (H/V)	Result
1675	-37.79	-13	-24.79	-29.62	-39.51	1.62	5.49	H	Pass
2506	-50.70	-13	-37.70	-44.47	-52.67	2.1	6.22	H	Pass
3343	-52.80	-13	-39.80	-46.97	-55.69	3.03	8.07	H	Pass



Band :	WCDMA Band V	Temperature :	24~25°C
Test Mode :	RMC 12.2Kbps Link (QPSK)	Relative Humidity :	42~43%
Test Engineer :	Elvis Chen and David Yang	Polarization :	Vertical
Remark :	Spurious emissions within 30-1000MHz were found more than 20dB below limit line.		

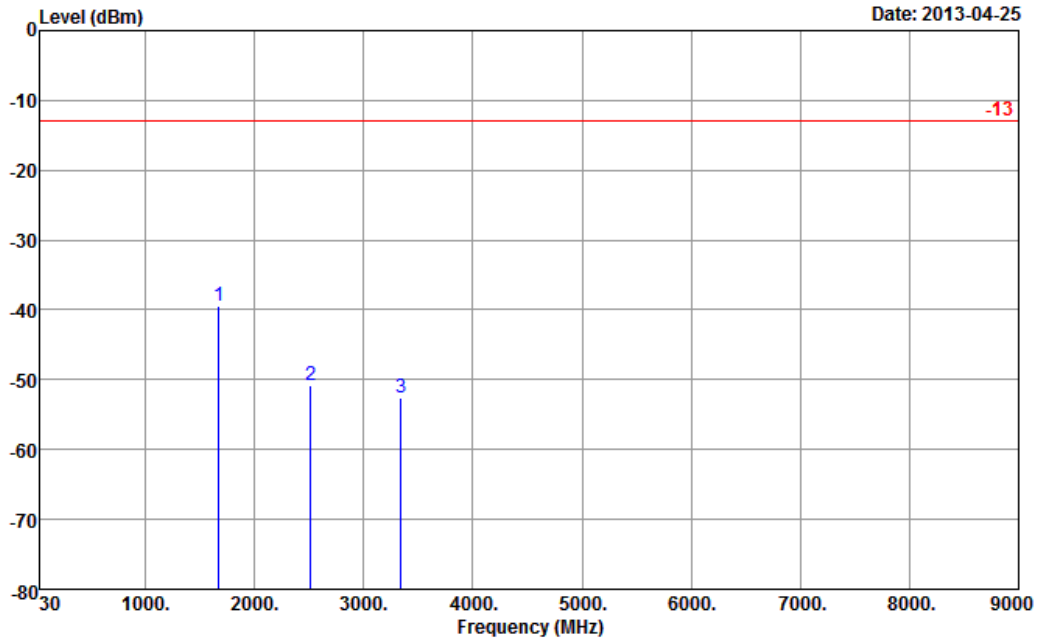

Site : 03CH08-HY
 Condition : -13 EIRP_130315 VERTICAL
 Project : FG 322823-02

Frequency (MHz)	ERP (dBm)	Limit (dBm)	Over Limit (dB)	SPA Reading (dBm)	S.G. Power (dBm)	TX Cable loss (dB)	TX Antenna Gain (dBi)	Polarization (H/V)	Result
1675	-39.44	-13	-26.44	-29.22	-41.16	1.62	5.49	V	Pass
2515	-50.77	-13	-37.77	-42.93	-52.74	2.1	6.22	V	Pass
3343	-52.48	-13	-39.48	-46.43	-55.37	3.03	8.07	V	Pass



Band :	WCDMA Band IV	Temperature :	24~25°C
Test Mode :	RMC 12.2Kbps Link (QPSK)	Relative Humidity :	42~43%
Test Engineer :	Elvis Chen and David Yang	Polarization :	Horizontal
Remark :	Spurious emissions within 30-1000MHz were found more than 20dB below limit line.		

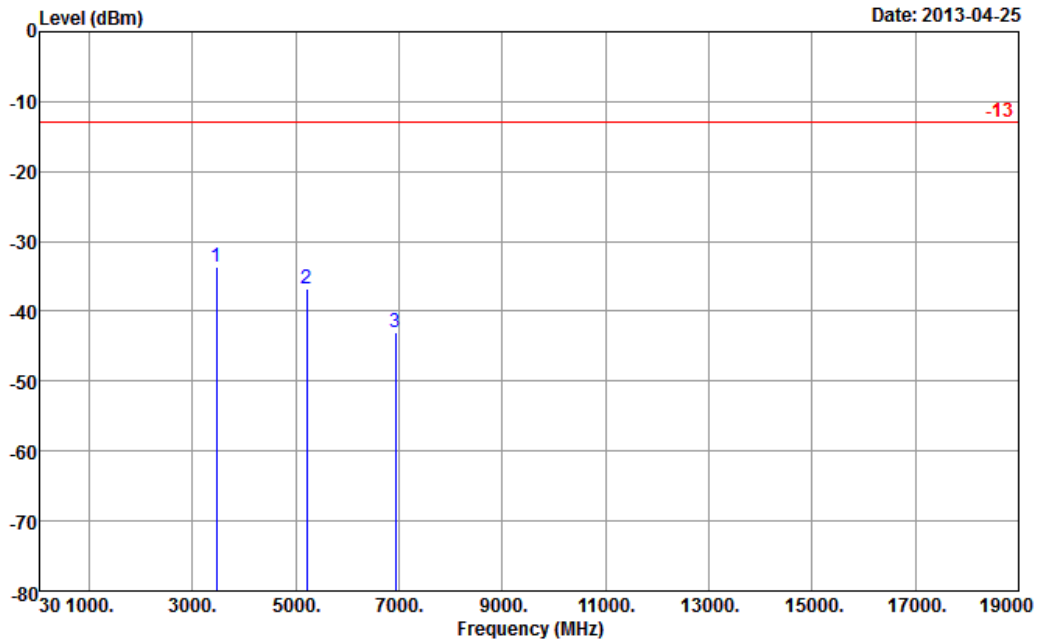

Site : 03CH08-HY
 Condition : -13 EIRP_130315 HORIZONTAL
 Project : FG 322823-02

Frequency (MHz)	EIRP (dBm)	Limit (dBm)	Over Limit (dB)	SPA Reading (dBm)	S.G. Power (dBm)	TX Cable loss (dB)	TX Antenna Gain (dBi)	Polarization (H/V)	Result
3468	-33.62	-13	-20.62	-28.69	-37.45	4.48	8.31	H	Pass
5204	-36.69	-13	-23.69	-34.5	-41.33	5.332	9.98	H	Pass
6932	-43.03	-13	-30.03	-44.96	-48.27	6.1	11.34	H	Pass



Band :	WCDMA Band IV	Temperature :	24~25°C
Test Mode :	RMC 12.2Kbps Link (QPSK)	Relative Humidity :	42~43%
Test Engineer :	Elvis Chen and David Yang	Polarization :	Vertical
Remark :	Spurious emissions within 30-1000MHz were found more than 20dB below limit line.		

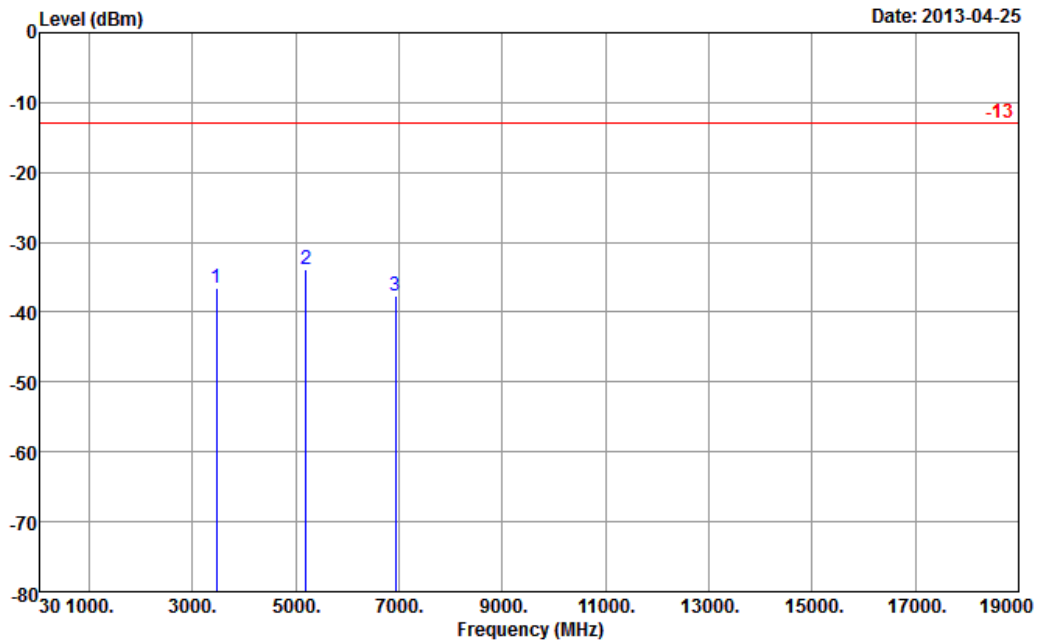

Site : 03CH08-HY
 Condition : -13 EIRP_130315 VERTICAL
 Project : FG 322823-02

Frequency (MHz)	EIRP (dBm)	Limit (dBm)	Over Limit (dB)	SPA Reading (dBm)	S.G. Power (dBm)	TX Cable loss (dB)	TX Antenna Gain (dBi)	Polarization (H/V)	Result
3464	-36.53	-13	-23.53	-31.03	-40.36	4.48	8.31	V	Pass
5196	-33.78	-13	-20.78	-31.33	-38.42	5.332	9.98	V	Pass
6936	-37.55	-13	-24.55	-40.16	-42.79	6.1	11.34	V	Pass



Band :	WCDMA Band II	Temperature :	24~25°C
Test Mode :	RMC 12.2Kbps Link (QPSK)	Relative Humidity :	42~43%
Test Engineer :	Elvis Chen and David Yang	Polarization :	Horizontal
Remark :	Spurious emissions within 30-1000MHz were found more than 20dB below limit line.		

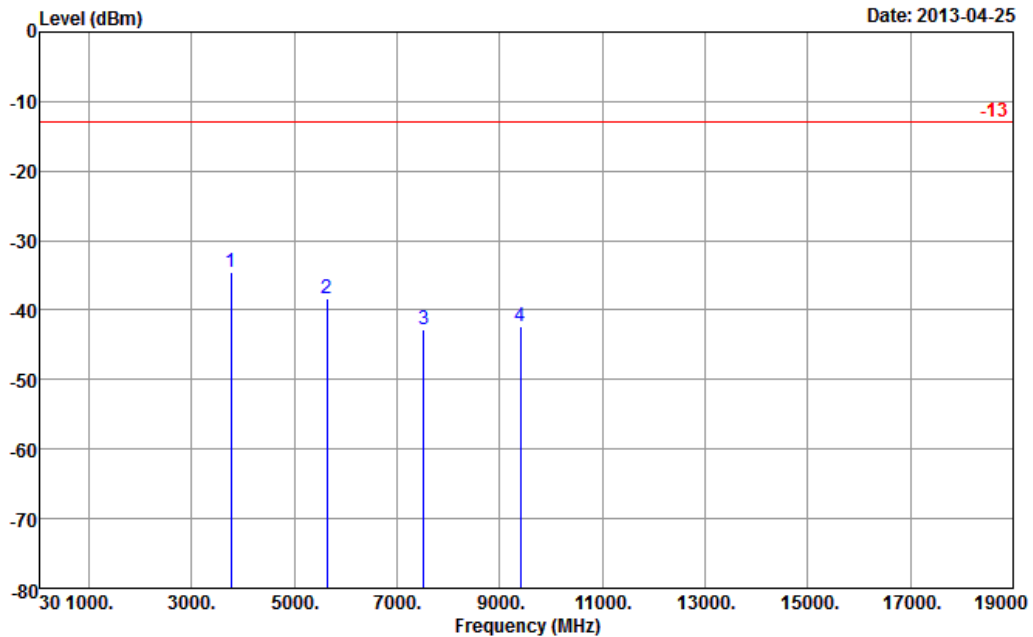

Site : 03CH08-HY
 Condition : -13 EIRP_130315 HORIZONTAL
 Project : FG 322823-02

Frequency (MHz)	EIRP (dBm)	Limit (dBm)	Over Limit (dB)	SPA Reading (dBm)	S.G. Power (dBm)	TX Cable loss (dB)	TX Antenna Gain (dBi)	Polarization (H/V)	Result
3760	-34.55	-13	-21.55	-29.96	-40.85	2.51	8.81	H	Pass
5636	-38.39	-13	-25.39	-35.15	-46.1	2.99	10.70	H	Pass
7524	-42.77	-13	-29.77	-45.24	-51.3	3.59	12.12	H	Pass
9396	-42.36	-13	-29.36	-47.21	-51.46	4.1	13.20	H	Pass



Band :	WCDMA Band II	Temperature :	24~25°C
Test Mode :	RMC 12.2Kbps Link (QPSK)	Relative Humidity :	42~43%
Test Engineer :	Elvis Chen and David Yang	Polarization :	Vertical
Remark :	Spurious emissions within 30-1000MHz were found more than 20dB below limit line.		

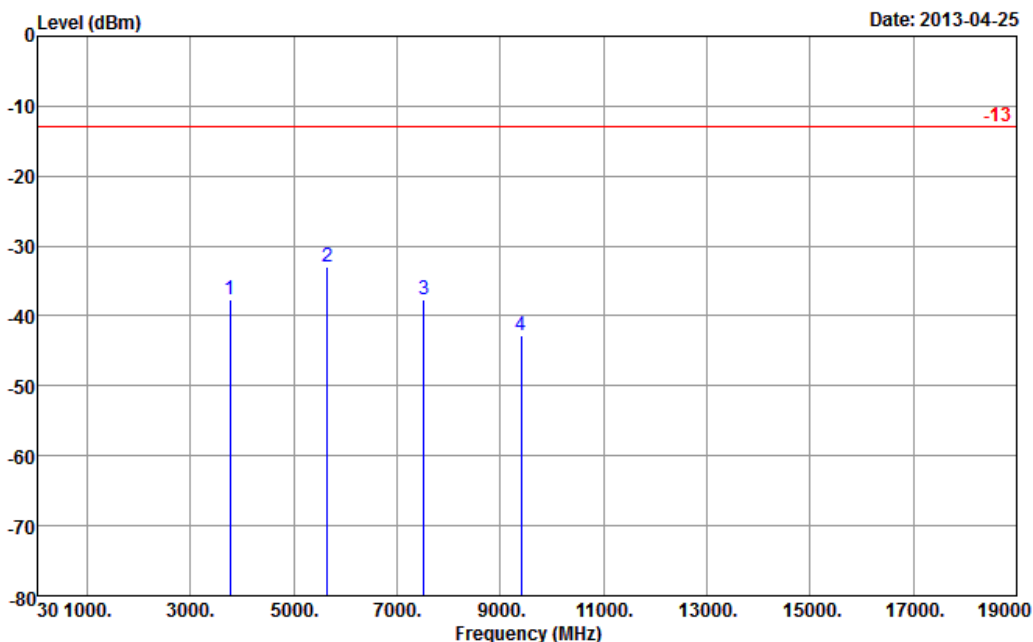

Site : 03CH08-HY
 Condition : -13 EIRP_130315 VERTICAL
 Project : FG 322823-02

Frequency (MHz)	EIRP (dBm)	Limit (dBm)	Over Limit (dB)	SPA Reading (dBm)	S.G. Power (dBm)	TX Cable loss (dB)	TX Antenna Gain (dBi)	Polarization (H/V)	Result
3760	-37.58	-13	-24.58	-32.66	-43.88	2.51	8.81	V	Pass
5644	-32.88	-13	-19.88	-31.36	-40.59	2.99	10.70	V	Pass
7512	-37.57	-13	-24.57	-40.87	-46.1	3.59	12.12	V	Pass
9408	-42.80	-13	-29.80	-48.02	-51.9	4.1	13.20	V	Pass



4 List of Measuring Equipments

Instrument	Manufacturer	Model No.	Serial No.	Characteristics	Calibration Date	Test Date	Due Date	Remark
System Simulator	R&S	CMU200	117995	N/A	Jul. 30, 2012	Apr. 25, 2013~ Apr. 26, 2013	Jul. 29, 2013	Conducted (TH02-HY)
Spectrum Analyzer	R&S	FSP40	100055	9kHz~40GHz	Jun. 06, 2012	Apr. 25, 2013~ Apr. 26, 2013	Jun. 05, 2013	Conducted (TH02-HY)
Spectrum Analyzer	R&S	ESU26	100390	20Hz~26.5GHz	Dec. 14, 2012	Apr. 25 2013	Dec. 13, 2013	Radiation (03CH08HY)
Bilog Antenna	Schaffner	CBL6111C	2725	30MHz~2GHz	Oct. 06, 2012	Apr. 25 2013	Oct. 05, 2013	Radiation (03CH08HY)
Turn Table	HD	Deis HD 2000	420/611	0 ~ 360 degree	N/A	Apr. 25 2013	N/A	Radiation (03CH08HY)
Antenna Mast	HD	MA 240	240/666	1 m ~ 4 m	N/A	Apr. 25 2013	N/A	Radiation (03CH08HY)
Horn Antenna	ESCO	3117	66584	1GHz~18GHz	Aug. 10, 2012	Apr. 25 2013	Aug. 09, 2013	Radiation (03CH08HY)
Pre Amplifier	Agilent	8449B	3008A02665	1GHz~26.5GHz	Aug. 28, 2012	Apr. 25 2013	Aug. 27, 2013	Radiation (03CH08HY)
SHF-EHF Horn Antenna	SCHWARZBECK	BBHA 9170	BBHA917025 1	15GHz ~ 40GHz	Sep. 28, 2012	Apr. 25 2013	Sep. 27, 2013	Radiation (03CH08HY)
Preamplifier	COM-POWER	PA-103	161075	10Hz~1000MHz Gain:32dB	Feb. 26, 2013	Apr. 25 2013	Feb. 25, 2014	Radiation (03CH08HY)



5 Uncertainty of Evaluation

Uncertainty of Radiated Emission Measurement (30 MHz ~ 1000 MHz)

Measuring Uncertainty for a Level of Confidence of 95% ($U = 2Uc(y)$)	2.54
---	------

Uncertainty of Radiated Emission Measurement (1 GHz ~ 40 GHz)

Measuring Uncertainty for a Level of Confidence of 95% ($U = 2Uc(y)$)	4.72
---	------



Appendix A. Photographs of EUT

Please refer to Sporton report number EP322823-08 as below.