

MEASUREMENT REPORT
of
WIFI MODULE
for
Class II permissive change

Applicant : PEGATRON CORPORATION
EUT : WIFI module
Model : AWM6018-P
FCC ID : VUIAWM6018P

Tested by :

Training Research Co., Ltd.

TEL : 886-2-26935155 FAX : 886-2-26934440

No. 255, Nanyang Street, Shijr, Taipei Hsien 221, Taiwan, R.O.C.

CERTIFICATION

We here by verify that:

The test data, data evaluation, test procedures and equipment configurations shown in this report were made mainly in accordance with the procedures given in ANSI C63.4 (2003) as a reference. All test were conducted by *Training Research Co., Ltd.*, 255 Nanyang Street, Shijr, Taipei Hsien 221, Taiwan, R.O.C. Also, we attest to the accuracy of each.

We further submit that the energy emitted by the sample EUT tested as described in the report is **in compliance with** the technical requirements set forth in the FCC Rules Part 15 Subpart C Section 15.247.

Applicant : PEGATRON CORPORATION
Applicant Address : 5F, NO. 76, LIGONG ST., BEITOU DISTRICT,
TAIPEI CITY, Taiwan
FCC ID : VUIAWM6018P
Report No. : P5515090253
Test Date : December 7, 2009

Prepared by:

Jack Tsai

Approved by:

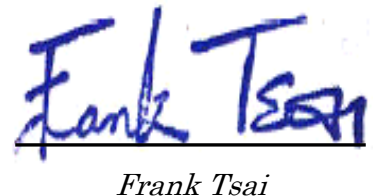
Frank Tsai

Conditions of issue :

- (1) **This test report shall not be reproduced except in full, without written approval of TRC. And the test result contained within this report only relate to the sample submitted for testing.**
- (2) **This report must not be used by the client to claim product endorsement by NVLAP or any agency of U.S. Government.**
- (3) **This test report, measurements made by TRC are traceable to the NIST only Conducted and Radiated Method.**



Tables of Contents

I. GENERAL	4
1.1 Introduction	4
1.2 Description of EUT	4
1.3 Test method	4
1.4 Description of Support Equipment	5
1.5 Configuration of System Under Test	7
1.6 Verify the Frequency and Channel	8
1.7 Test Procedure	9
1.8 Location of the Test Site	9
1.9 General Test Condition	9
II. Section 15.203 : Antenna Requirement	10
III. Section 15.207 : Power Line Conducted Emissions for AC Powered Units	11
3.1 Test Condition & Setup	11
3.2 List of Test Instruments	12
3.3 Test Result of Conducted Emissions	13
IEEE 802.11b TX mode	13
IEEE 802.11g TX mode	15
IV. Section 15.247(a) : Technical Description of the EUT.....	17
V. Section 15.247(c) : Spurious Emissions (Radiated)	18
5.1 Test Condition & Setup	18
5.2 List of Test Instruments	20
5.3 Test Result of Spurious Radiated Emissions	21
IEEE 802.11b TX mode	21
IEEE 802.11g TX mode	27
5.4 Test Result of Bandedge.....	33
IEEE 802.11b TX mode	34
IEEE 802.11g TX mode	36

I . GENERAL

1.1 Introduction

The following measurement report is submitted on behalf of applicant in support that the certification in accordance with Part 2 Subpart J and Part 15 Subpart A, and C of the Commission's Rules and Regulations.

1.2 Description of EUT

Product Name	:	WIFI Module
Model Name	:	AWM6018-P
FCC ID	:	VUIAWM6018P
Frequency Range	:	2.412 GHz ~ 2.462GHz
Support Channel	:	11 Channels
Channel Spacing	:	5MHz
Modulation Skill	:	DBPSK, DQPSK, CCK, OFDM
Power Type	:	Powered by Mini-PCI interface of client's device

1.3 Test method

1. Insert the EUT into the mini-PCI interface of the test fixture (which is transferred from PCMCIA to mini-PCI interface).
2. Using the computer and software provided by the manufacturer to control EUT. The software is operated under the Windows to control the EUT in the mode of continuous transmission; the test is performed under the specific conditions.
3. Set different channel and data rate being tested and repeat the procedures above.
 - (a) Conduction test and Radiated for Intentional test:
making EUT to the mode of continuous transmission

1.4 Description of Support Equipment

In order to construct the minimum testing, following equipment were used as the support units.

PC : DELL OPTIPLEX 755
Model No. : DC8M
Serial No. : 58Y9T1S
FCC ID : DoC Approved
BSMI : R33002
Power type : 100 ~ 127VAC/200 ~ 240VAC, 6A/3A, 50 ~ 60Hz, Switching
Power cord : Non-shielded, 1.8m long, Plastic hood, No ferrite core

Monitor : **HP 15' Color Monitor**
Model No. : D8894A
Serial No. : CN02364355
FCC ID : ARSCM356N
BSMI : 3882A031
Power type : 100 ~ 240 VAC / 1.5A, 50 ~ 60 Hz, Switching
Power cord : Non-shielded, 1.80m length, Plastic hood, No ferrite core
Data cable : Shielded, 1.50m length, Plastic hood, with ferrite core

USB Mouse : **HP**
Model No. : M056UC
Serial No. : G1B00Q8G
FCC ID : DoC Approved
BSMI : R41108
Power type : By PC
Data cable : Shielded, 1.82m length, Plastic hood, No ferrite core

USB Keyboard : **DELL**
Model No. : SK-8115
Serial No. : MY-0DT325-71619-7CH-0790
FCC ID : DoC Approved
BSMI : T3A002
Power type : By PC
Data cable : Shielded, 2.0m length, Plastic hood, with ferrite core

PCMCIA to Mini PCI :PEGATRON CORPORATION

Model No. : Test Fixture

Power type : By PC

PCMCIA to PCI adapter:Ean Digital Systems Ltd.

Model No. : 119-1622

Serial No. : P16013700089089

FCC ID : DoC Approved

Power type : By PC

1.5 Configuration of System Under Test

1.5.1 Conducted and Radiated Emission Test

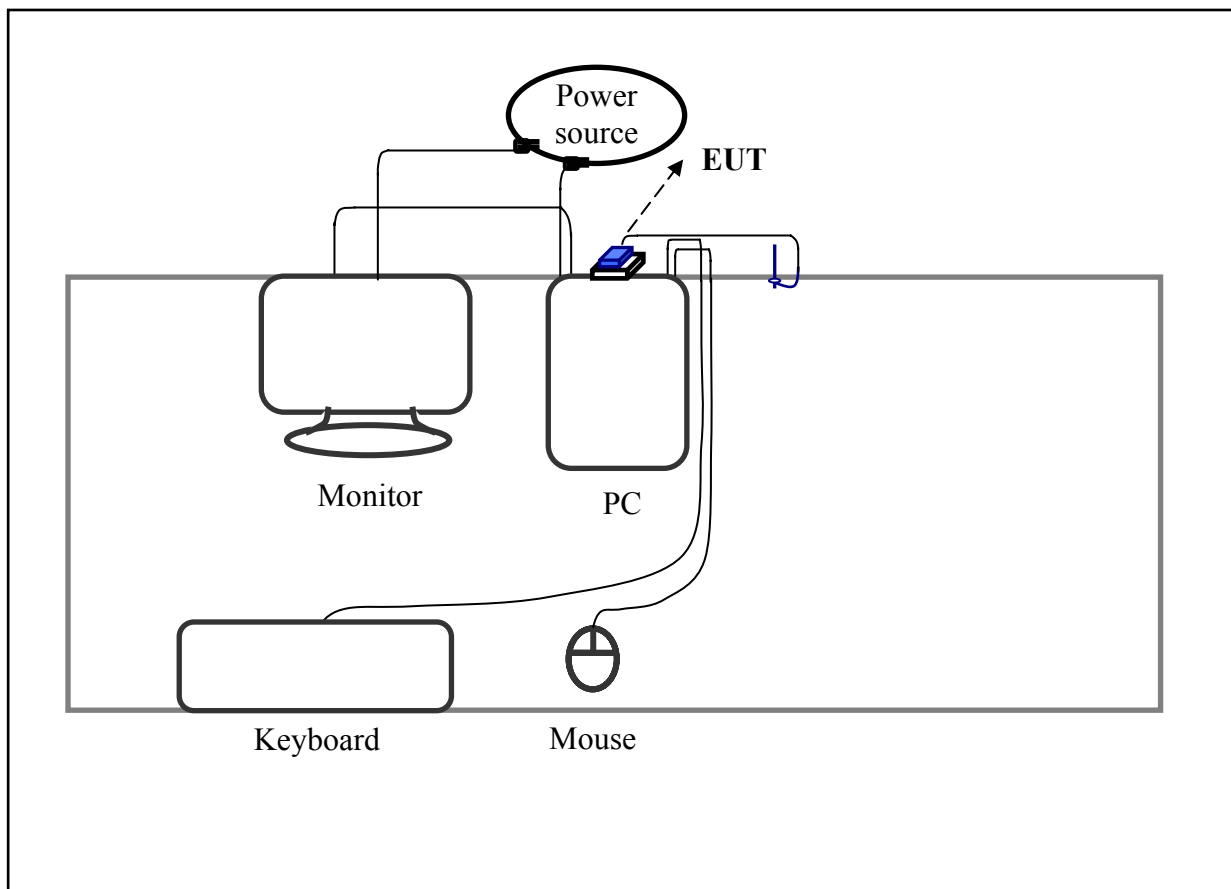

Connections of Equipment

- PC:**
- *VGA Port a monitor
 - * USB#1 Port a keyboard
 - * USB#2 Port a mouse
 - *Mini-PCI Port **EUT**

The tests below are carried with the EUT transmitter set at high power in TDD mode. The EUT is forced to select of output power level and channel number by PCMCIA interface of PC.

The setting up procedure was recorded in 1.3 test method.

1.6 Verify the Frequency and Channel

Channel	Frequency (GHz)
1	2.412
2	2.417
3	2.422
4	2.427
5	2.432
6	2.437
7	2.442
8	2.447
9	2.452
10	2.457
11	2.462

Note:

1. This is for confirming that all frequencies are in 2.412GHz to 2.462GHz.
2. Section 15.31(m): Measurements on intentional radiators or receivers shall be performed at three frequencies for operating frequency range over 10 MHz.
(The locations of these frequencies one near the top, one near the middle and one near the bottom.)
3. After test, the EUT operating frequencies are in 2.412GHz to 2.462GHz. So all the items as followed in testing report are need to test these three frequencies:
Top: Channel – 1; Middle: Channel – 6; Bottom: Channel – 11.

1.7 Test Procedure

All measurements contained in this report were performed mainly according to the techniques described in ANSI C63.4 (2003) and the pre-setup was written on 1.3 test method, the detail setup was written on each test item.

1.8 Location of the Test Site

The radiated emissions measurements required by the rules were performed on the **three-meter, Semi-anechoic Chamber (FCC Registration Number: 93906)** maintained by *Training Research Co., Ltd.* 1F, No. 255 Nanyang Street, Shijr, Taipei Hsien 221, Taiwan, R.O.C. Complete description and measurement data have been placed on file with the commission. The conducted power line emissions tests and other test items were performed in a semi-anechoic chamber also located at Training Research Co., Ltd.

No. 255 Nanyang Street, Shijr, Taipei Hsien 221, Taiwan, R.O.C. *Training Research Co., Ltd.* is listed by the FCC as a facility available to do measurement work for others on a contract basis.

1.9 General Test Condition

The conditions under which the EUT operates were varied to determine their effect on the equipment's emission characteristics. The final configuration of the test system and the mode of operation used during these tests were chosen as that which produced the highest emission levels. However, only those conditions, which the EUT was considered likely to encounter in normal use were investigated.

In test, they were set in high power and continuously transmitting mode that controlled by computer. The ch01, ch06 and ch11 of EUT were all tested. The setting up procedure is recorded on 1.3 test method.

II. Section 15.203: Antenna requirement

The EUT can be equipped with detachable antenna. The external antenna is affixed to the EUT using a unique connector. The antenna requirement stated in Section 15.203 is inapplicable to this EUT.

The antenna specification of list as follows,

Antenna No.	Antenna Manufacturer	Model	Connector	Antenna Type	Antenna Gain (Max.)
Antenna#1 (MAIN RF Output)	Suzhou Wanshih Electronic Element Co., Ltd.	14G156012330	MHF	PIFA	0.56dBi
Antenna#2 (AUX RF Output)	WHA YU GROUP	C660-510003-A	SMA Plug Reverse	Dipole	1.8dBi

Note:

- 1) For more detailed features description, please reference to the Antenna Specifications. (Please reference to RF Exposure Information)

III. Section 15.207: Power Line Conducted Emissions for AC Powered Units

3.1 Test Condition & Setup

The power line conducted emission measurements were performed in an semi-anechoic chamber. The EUT was assembled on a wooden table, which is 80 centimeters high, was placed 40 centimeters from the backwall and at least 1 meter from the sidewall.

Power was fed to the EUT from the public utility power grid through a line filter and Line Impedance Stabilization Networks (LISNs). The LISN housing, measuring instrumentation case, ground plane, etc., were electrically bonded together at the same RF potential. The Spectrum analyzer (or EMI receiver) was connected to the AC line through an isolation transformer. The 50-ohm output of the LISN was connected to the spectrum analyzer directly. Conducted emission levels were in the CISPR quasi-peak and average detection mode. The analyzer's 6 dB bandwidth was set to 9KHz. No post-detector video filter was used.

The spectrum was scanned from 150KHz to 30MHz. The physical arrangement of the test system and associated cabling was varied (within the scope of arrangements likely to be encountered in actual use) to determine the effect on the unit's emanations in amplitude and frequency. All spurious emission frequencies were observed. The highest emission amplitudes relative to the appropriate limit were measured and have been recorded in paragraph 4.3.

There is a test condition apply in this test item, the test procedure description as <1.3>. Three channels were tested, one in the top (CH01), one in the middle (CH06) and the other in bottom (CH11).

3.2 List of Test Instruments

				<u>Calibration Date</u>
Instrument Name	Model	Brand	Serial No.	Next time
EMI Receiver	8546A	HP	3520A00242	01/15/10
RF Filter Section	85460A	HP	3448A00217	01/15/10
LISN (EUT)	LISN-01	TRC	99-05	02/10/10
LISN (Support E.)	LISN-01	TRC	9912-03, 04	12/22/09
Pre-amplifier	15542 ZFL-500	Mini – Circuits	0 0117	01/10/10
6dB Attenuator	MCL BW-S6W2	Mini – Circuits	9915 – Conducted	01/10/10
10dB Attenuator	A5542 VAT010	Mini – Circuits	0215 – Conducted	01/10/10
Coaxial Cable (2.0 meter)	A30A30-0058-50FS-2M	Jyebao	SMA-08	01/10/10
Coaxial Cable (1.1 meter)	A30A30-0058-50FS-1M	Jyebao	SMA-09	01/10/10
Coaxial Cable (20 meter)	RG-214/U	Jyebao	NP-01	01/10/10
Coaxial Cable (20 meter)	RG-214/U	Jyebao	NP-02	01/10/10
Auto Switch Box (< 30MHz)	ASB-01	TRC	9904-01	01/10/10

3.3 Test Result of Power Line Conducted Emissions

The following table shows a summary of the highest emissions of power line conducted emissions on the LIVE and NETURAL conductors of the EUT power cord. Show as follows.

Test Conditions: Temperature : 25 °C Humidity : 73 % RH

Test mode: IEEE 802.11b Channel 1

<i>Power Connected Emissions</i>					<i>Class B</i>		
<i>Conductor</i>	<i>Frequency (KHz)</i>	<i>Peak (dBµV)</i>	<i>QP (dBµV)</i>	<i>Average (dBµV)</i>	<i>QP-limit (dBµV)</i>	<i>AVG-limit (dBµV)</i>	<i>Margin (dB)</i>
Line 1	394.000	28.69	---	---	59.03	49.03	-20.34
	604.000	25.18	---	---	56.00	46.00	-20.82
	1836.000	25.95	---	---	56.00	46.00	-20.05
	5000.000	34.67	---	---	60.00	50.00	-15.33
	9980.000	44.19	---	---	60.00	50.00	-5.81
	21740.000	41.37	---	---	60.00	50.00	-8.63
Line 2	164.000	37.38	---	---	65.60	55.60	-18.22
	195.000	35.86	---	---	64.71	54.71	-18.85
	781.000	26.85	---	---	56.00	46.00	-19.15
	5000.000	35.25	---	---	60.00	50.00	-14.75
	9980.000	44.08	---	---	60.00	50.00	-5.92
	21740.000	40.88	---	---	60.00	50.00	-9.12

NOTE:

- (1)Margin = Peak Amplitude – Limit, *The reading amplitudes are all under limit.*
- (2)A "+" sign in the margin column means the emission is OVER the Class B Limit, and
 "-" sign of means UNDER the Class B limit

Test mode: IEEE 802.11b Channel 6

Power Connected Emissions					Class B		
Conductor	Frequency (KHz)	Peak (dBμV)	QP (dBμV)	Average (dBμV)	QP-limit (dBμV)	AVG-limit (dBμV)	Margin (dB)
Line 1	1836.000	26.51	---	---	56.00	46.00	-19.49
	3413.000	27.55	---	---	56.00	46.00	-18.45
	5000.000	34.00	---	---	60.00	50.00	-16.00
	980.000	44.29	---	---	60.00	50.00	-5.71
	17000.000	33.88	---	---	60.00	50.00	-16.12
	21740.000	39.91	---	---	60.00	50.00	-10.09
Line 2	264.000	35.08	---	---	62.74	52.74	-17.66
	781.000	27.48	---	---	56.00	46.00	-18.52
	5000.000	34.72	---	---	60.00	50.00	-15.28
	9980.000	44.22	---	---	60.00	50.00	-5.78
	16740.000	33.69	---	---	60.00	50.00	-16.31
	21740.000	41.55	---	---	60.00	50.00	-8.45

Test mode: IEEE 802.11b Channel 11

Power Connected Emissions					Class B		
Conductor	Frequency (KHz)	Peak (dBμV)	QP (dBμV)	Average (dBμV)	QP-limit (dBμV)	AVG-limit (dBμV)	Margin (dB)
Line 1	587.000	25.46	---	---	56.00	46.00	-20.54
	1836.000	26.83	---	---	56.00	46.00	-19.17
	3381.000	27.04	---	---	56.00	46.00	-18.96
	5000.000	34.02	---	---	60.00	50.00	-15.98
	9980.000	43.19	---	---	60.00	50.00	-6.81
	21740.000	40.50	---	---	60.00	50.00	-9.50
Line 2	179.000	36.31	---	---	65.17	55.17	-18.86
	201.000	35.87	---	---	64.54	54.54	-18.67
	781.000	27.22	---	---	56.00	46.00	-18.78
	5000.000	33.49	---	---	60.00	50.00	-16.51
	9930.000	38.31	---	---	60.00	50.00	-11.69
	21740.000	41.55	---	---	60.00	50.00	-8.45

Test mode: IEEE 802.11g Channel 1

Power Connected Emissions					Class B		
Conductor	Frequency (KHz)	Peak (dBμV)	QP (dBμV)	Average (dBμV)	QP-limit (dBμV)	AVG-limit (dBμV)	Margin (dB)
Line 1	604.000	26.19	---	---	56.00	46.00	-19.81
	788.000	26.65	---	---	56.00	46.00	-19.35
	2872.000	27.78	---	---	56.00	46.00	-18.22
	10030.000	36.29	---	---	60.00	50.00	-13.71
	16400.000	33.52	---	---	60.00	50.00	-16.48
	21740.000	40.26	---	---	60.00	50.00	-9.74
Line 2	175.000	36.68	---	---	65.29	55.29	-18.61
	199.000	36.14	---	---	64.60	54.60	-18.46
	262.000	35.10	---	---	62.80	52.80	-17.70
	5000.000	34.27	---	---	60.00	50.00	-15.73
	9980.000	43.92	---	---	60.00	50.00	-6.08
	21740.000	41.18	---	---	60.00	50.00	-8.82

Test mode: IEEE 802.11g Channel 6

Power Connected Emissions					Class B		
Conductor	Frequency (KHz)	Peak (dBμV)	QP (dBμV)	Average (dBμV)	QP-limit (dBμV)	AVG-limit (dBμV)	Margin (dB)
Line 1	627.000	26.16	---	---	56.00	46.00	-19.84
	2741.000	28.11	---	---	56.00	46.00	-17.89
	5000.000	33.89	---	---	60.00	50.00	-16.11
	9980.000	44.05	---	---	60.00	50.00	-5.95
	16740.000	34.02	---	---	60.00	50.00	-15.98
	21740.000	39.39	---	---	60.00	50.00	-10.61
Line 2	201.000	36.07	---	---	64.54	54.54	-18.47
	262.000	34.63	---	---	62.80	52.80	-18.17
	2741.000	27.76	---	---	56.00	46.00	-18.24
	9980.000	44.12	---	---	60.00	50.00	-5.88
	16320.000	33.83	---	---	60.00	50.00	-16.17
	21630.000	39.93	---	---	60.00	50.00	-10.07

Test mode: IEEE 802.11g Channel 11

<i>Power Connected Emissions</i>					<i>FCC Class B</i>		
<i>Conductor</i>	<i>Frequency (KHz)</i>	<i>Peak (dBμV)</i>	<i>QP (dBμV)</i>	<i>Average (dBμV)</i>	<i>QP-limit (dBμV)</i>	<i>AVG-limit (dBμV)</i>	<i>Margin (dB)</i>
Line 1	166.000	34.54	---	---	65.54	55.54	-21.00
	2741.000	28.11	---	---	56.00	46.00	-17.89
	5000.000	34.80	---	---	60.00	50.00	-15.20
	9930.000	39.27	---	---	60.00	50.00	-10.73
	16660.000	33.56	---	---	60.00	50.00	-16.44
	21740.000	40.26	---	---	60.00	50.00	-9.74
Line 2	197.000	36.02	---	---	64.66	54.66	-18.64
	2741.000	27.44	---	---	56.00	46.00	-18.56
	5000.000	34.27	---	---	60.00	50.00	-15.73
	9980.000	44.17	---	---	60.00	50.00	-5.83
	16320.000	33.54	---	---	60.00	50.00	-16.46
	21740.000	39.44	---	---	60.00	50.00	-10.56

VI. Section 15.247 (a): Technical description of the EUT

Direct Sequence System is a spread spectrum system in which the carrier has been modulated by a high speed spreading code and an information data stream. The high speed code sequence dominates the “modulating function” and is the direct cause of the wide spreading of the transmitted signal. In the operational description demonstrates the operation principles of the Baseband processor employed by the EUT, shows that which is a complete DSSS baseband processor and meets the definition of the direct sequence spread spectrum system.

V. Section 15.247 (C): Spurious Emissions (Radiated)

5.1 Test Condition & Setup

We'd performed the test by the *radiated emission* skill: The EUT was placed in an semi-anechoic chamber, and set the EUT transmitting continuously and scanned at 3-meter distance to determine its emission characteristics. The physical arrangement of the EUT was varied (within the scope of arrangements likely to be encountered in actual use) to determine the effect on the unit's emanations in amplitude, directivity, and frequency. The exact system configuration, which produced the highest emissions was noted so it could be reproduced later during the final tests. For the measurement above 1GHz, according to the guidance we'd set the spectrum analyzer's 6dB bandwidth RBW to 1MHz.

This was done to ensure that the final measurements would demonstrate the worst-case interference potential of the EUT.

Final radiation measurements were made on a three-meter, semi-anechoic chamber. The EUT system was placed on a nonconductive turntable, which is 0.8 meters height, top surface 1.0 x 1.5 meter.

The spectrum was examined from 30 MHz to 1000 MHz using an Hewlett Packard 85460A EMI Receiver, SCHWARZECK whole range Small Biconical Antenna (Model No.: UBAA9114 & BBVU9135) is used to measure frequency from 30 MHz to 1GHz. The final test is used the HP 85460A spectrum and 8564E spectrum was examined from 1GHz to 25GHz using an Hewlett Packard Spectrum Analyzer, EMCO/HP Horn Antenna (Model 3115 / 84125-80008) for 1G - 25GHz.

At each frequency, the EUT was rotated 360 degrees, and the antenna was raised and lowered from one to four meters to find the maximum emission levels. Measurements were taken using both horizontal and vertical antenna polarization.

Appropriate preamplifiers were used for improving sensitivity and precautions were taken to avoid overloading or desensitizing the spectrum analyzer. There are two spectrum analyzers use on this testing, HP 85460A for frequency 30MHz to 1000MHz, and 8564E for frequency 1GHz to 25GHz. No post-detector video filters were used in the test. The spectrum analyzer's 6dB bandwidth was set to 120KHz (spectrum was examined from 30 MHz to 1000 MHz), the spectrum analyzer's 6 dB bandwidth was set to 1 MHz (spectrum was examined from 1GHz to 25GHz) and the analyzer was operated in the maximum hold mode. There is a test condition applies in this test item, the test procedure description as the following:

Three channels were tested, one in the top (CH01), one in the middle (CH06) and the other in bottom (CH11). The setting up procedure is recorded on <1.3>

With the transmitter operating from a AC source and using the internal of EUT, radiates spurious emissions falling within the restricted bands of 15.209 were measured at operating frequencies corresponding to upper, middle and bottom channels in the 2400 ~ 2483.5 MHz band.

The actual field intensity in decibels referenced to 1 microvolt per meter (dB μ V/m) is determined by algebraically adding the measured reading in dB μ V, the antenna factor (dB), and cable loss (dB) at the appropriate frequency. Since the EUT was set to transmit continuously, no *duty cycle* is present.

For frequency between 30MHz to 1000MHz

$$F_{Ia} \text{ (dBuV/m)} = F_{Ir} \text{ (dB}\mu\text{V)} + \text{Correction Factors}$$

F_{Ia} : Actual Field Intensity

F_{Ir} : Reading of the Field Intensity

Correction Factors = Antenna Factor + (Cable Loss – Amplitude Gain) + Switching Box Loss

For frequency between 1GHz to 25GHz

$$F_{Ia} \text{ (dB}\mu\text{V/m)} = F_{Ir} \text{ (dB}\mu\text{V)} + \text{Correction Factor}$$

F_{Ia} : Actual Field Intensity

F_{Ir} : Reading of the Field Intensity

Correction Factors = Antenna Factor + (Cable Loss – Amplitude Gain) + Switching Box Loss

5.2 List of Test Instruments

Instrument Name	Model	Brand	Serial No.	Calibration Date
				Next time
EMI Receiver	8546A	HP	3520A00242	01/15/10
RF Filter Section	85460A	HP	3448A00217	01/15/10
Small Biconical Antenna	UBAA9114 & BBVU9135	SCHWARZECK	127	01/10/10
Pre-amplifier	PA1F	TRC	1FAC	01/10/10
Coaxial Cable (Double shielded, 15 meter)	A30A30-0058-50FS-15M	JYEBAO	SMA-01	01/10/10
Coaxial Cable (1.1 meter)	A30A30-0058-50FS-1M	JYEBAO	SMA-02	01/10/10
Spectrum Analyzer	8564E	HP	3720A00840	12/17/09
Microwave Preamplifier	84125C	HP	US36433002	02/05/10
Horn Antenna	3115	EMCO	9104-3668	02/06/10
Standard Guide Horn Antenna	84125-80008	HP	18-26.5GHz	12/14/09
Standard Guide Horn Antenna	84125-80001	HP	26.5-40GHz	02/12/10
Horn Antenna	1196E (3115)	HP (EMCO)	9704-5178	02/13/10
Pre-amplifier	PA2F	TRC	2F1GZ	01/10/10
Coaxial Cable (3 miter)	A30A30-0058-50FST118	JYEBAO	MSA-05	01/10/10
Coaxial Cable (1 meter)	A30A30-0058-50FST118	JYEBAO	MSA-04	01/10/10

5.3 Test Result of Spurious Radiated Emissions

The highest peak values of radiated emissions from the EUT at various antenna heights, antenna polarizations, EUT orientation, etc. are recorded on the following.

Test Conditions: Temperature : 25 °C Humidity : 73 % RH

Test mode: IEEE 802.11b CH01 for 30MHz to 1GHz [Horizontal]

Radiated Emission				Correction Factors (dB)	Corrected Amplitude (dBμV/m)	Class B (3 m)	
Frequency (MHz)	Amplitude (dBμV)	Ant. H. (m)	Table ()			Limit (dBμV/m)	Margin (dB)
187.62	41.47	1.00	72	-3.79	37.68	43.50	-5.82
362.22	44.93	1.00	62	-1.98	42.95	46.00	-3.05
365.01	38.04	1.00	75	-1.91	36.13	46.00	-9.87
396.17	44.14	1.00	75	-1.17	42.97	46.00	-3.03
528.34	37.83	1.00	39	3.62	41.45	46.00	-4.55
558.65	35.40	1.00	39	5.30	40.70	46.00	-5.30

Test mode: IEEE 802.11b CH01 for 30MHz to 1GHz [Vertical]

Radiated Emission				Correction Factors (dB)	Corrected Amplitude (dBμV/m)	Class B (3 m)	
Frequency (MHz)	Amplitude (dBμV)	Ant. H. (m)	Table ()			Limit (dBμV/m)	Margin (dB)
68.80	33.47	1.00	0	1.34	34.81	40.00	-5.19
74.86	31.67	1.00	247	0.98	32.65	40.00	-7.35
100.32	38.39	1.00	271	-0.57	37.82	43.50	-5.68
119.72	39.44	1.00	89	-2.38	37.06	43.50	-6.44
175.50	42.04	1.00	0	-4.04	38.00	43.50	-5.50
528.34	35.13	1.00	321	3.62	38.75	46.00	-7.25

Note:

1. Margin = Amplitude – limit, if margin is minus means under limit.
2. Corrected Amplitude = Reading Amplitude + Correction Factors
3. Correction factor = Antenna factor + (Cable Loss – Amplitude gain) + Switching Box Loss

Test mode: IEEE 802.11b CH01 for 1GHz to 25GHz [Horizontal]

Frequency	Ant. H.	Table	Amplitude		Correction Factor	Corrected Amplitude		Limit		Margin
			Peak / Ave.			Peak / Ave.		Peak / Ave.		
MHz	m	degree	dBµV		dB/m	dBµV/m		dBµV/m		dB
1608.33	1.00	295	37.00	---	14.20	51.20	---	73.96	53.96	-2.76
2152.74	1.00	109	44.50	33.33	8.52	53.02	41.85	73.96	53.96	-12.11
2539.58	1.00	162	38.67	---	9.56	48.23	---	73.96	53.96	-5.73
9650.42	1.00	247	35.61	---	11.47	47.08	---	73.96	53.96	-6.88
19296.25	1.00	12	44.93	---	1.60	48.51	---	73.96	53.96	-5.45
24120.00	1.00	82	44.56	---	3.40	47.96	---	73.96	53.96	-6.00

Test mode: IEEE 802.11b CH01 for 1GHz to 25GHz [Vertical]

Frequency	Ant. H.	Table	Amplitude		Correction Factor	Corrected Amplitude		Limit		Margin
			Peak / Ave.			Peak / Ave.		Peak / Ave.		
MHz	m	degree	dBµV		dB/m	dBµV/m		dBµV/m		dB
1608.00	1.00	173	38.32	32.50	14.21	52.53	46.71	73.96	53.96	-7.25
2518.75	1.00	132	41.00	---	9.53	50.53	---	73.96	53.96	-3.43
9650.42	1.00	294	37.44	---	11.47	48.91	---	73.96	53.96	-5.05
19296.25	1.00	312	47.05	---	1.60	48.65	---	73.96	53.96	-5.31
21708.21	1.00	12	45.05	---	2.87	47.92	---	73.96	53.96	-6.04
24120.00	1.00	90	44.71	---	3.40	48.11	---	73.96	53.96	-5.85

Note:

1. Margin = Corrected - Limit.
2. The EUT utilizes a *permanently attached antenna*. In addition the spurious RF radiated emissions levels do comply with the *20dBc limit* both at its bandedges and other spurious emissions.
3. As stated in Section 15.35(b), for any frequencies above 1000MHz, radiated limits shown are based upon the use of measurement instrumentation employing an average detector function. As the results of our test, the peak amplitudes are already below the FCC limit. Thus the average amplitudes of the rest are omitted.

Test mode: IEEE 802.11b CH06 for 30MHz to 1GHz [Horizontal]

Radiated Emission				Correction Factors (dB)	Corrected Amplitude (dBμV/m)	Class B (3 m)	
Frequency (MHz)	Amplitude (dBμV)	Ant. H. (m)	Table ()			Limit (dBμV/m)	Margin (dB)
173.07	41.17	1.00	52	-4.07	37.10	43.50	-6.40
188.84	40.62	1.00	90	-3.77	36.85	43.50	-6.65
359.80	46.01	1.00	59	-2.04	43.97	46.00	-2.03
366.14	37.29	1.00	83	-1.89	35.40	46.00	-10.60
528.34	37.99	1.00	36	3.62	41.61	46.00	-4.39
565.92	34.41	1.00	36	5.51	39.92	46.00	-6.08

Test mode: IEEE 802.11b CH06 for 30MHz to 1GHz [Vertical]

Radiated Emission				Correction Factors (dB)	Corrected Amplitude (dBμV/m)	Class B (3 m)	
Frequency (MHz)	Amplitude (dBμV)	Ant. H. (m)	Table ()			Limit (dBμV/m)	Margin (dB)
67.59	33.00	1.00	87	1.37	34.37	40.00	-5.63
86.99	35.96	1.00	38	0.20	36.16	40.00	-3.84
101.54	38.73	1.00	249	-0.73	38.00	43.50	-5.50
122.15	40.90	1.00	73	-2.53	38.37	43.50	-5.13
175.50	42.93	1.00	28	-4.04	38.89	43.50	-4.61
528.34	35.01	1.00	314	3.62	38.63	46.00	-7.37

Test mode: IEEE 802.11b CH06 for 1GHz to 25GHz [Horizontal]

Frequency	Ant. H.	Table	Amplitude		Correction Factor	Corrected Amplitude		Limit		Margin
			Peak / Ave.			Peak / Ave.		Peak / Ave.		
MHz	m	degree	dBµV		dB/m	dBµV/m		dBµV/m		dB
1624.66	1.00	247	38.49	32.00	13.95	52.44	45.95	73.96	53.96	-8.01
2154.18	1.00	354	50.16	33.00	8.52	58.68	41.52	73.96	53.96	-12.44
2525.00	1.00	146	39.46	---	9.74	49.20	---	73.96	53.96	-4.76
12187.92	1.00	186	38.60	---	9.74	48.34	---	73.96	53.96	-5.62
21934.79	1.00	177	45.78	---	3.09	48.87	---	73.96	53.96	-5.09
24371.46	1.00	206	46.08	---	3.26	49.34	---	73.96	53.96	-4.62

Test mode: IEEE 802.11b CH06 for 1GHz to 25GHz [Vertical]

Frequency	Ant. H.	Table	Amplitude		Correction Factor	Corrected Amplitude		Limit		Margin
			Peak / Ave.			Peak / Ave.		Peak / Ave.		
MHz	m	degree	dBµV		dB/m	dBµV/m		dBµV/m		dB
1624.66	1.00	179	39.16	32.33	13.95	53.11	46.28	73.96	53.96	-7.68
2159.16	1.00	254	49.14	38.83	8.54	57.68	47.37	73.96	53.96	-6.59
2525.00	1.00	92	39.33	---	9.54	48.87	---	73.96	53.96	-5.09
9747.08	1.00	150	37.10	---	11.89	48.99	---	73.96	53.96	-4.97
12187.92	1.00	162	39.27	---	9.74	49.01	---	73.96	53.96	-4.95
24371.46	1.00	198	45.71	---	3.26	48.97	---	73.96	53.96	-4.99

Test mode: IEEE 802.11b CH11 for 30MHz to 1GHz [Horizontal]

<i>Radiated Emission</i>				<i>Correction Factors</i>	<i>Corrected Amplitude</i>	<i>Class B (3 m)</i>	
<i>Frequency (MHz)</i>	<i>Amplitude (dBμV)</i>	<i>Ant. H. (m)</i>	<i>Table ()</i>			<i>Limit (dBμV/m)</i>	<i>Margin (dB)</i>
88.20	38.14	1.00	66	0.12	38.26	43.50	-5.24
361.01	46.63	1.00	48	-2.01	44.62	46.00	-1.38
365.07	39.43	1.00	62	-1.91	37.52	46.00	-8.48
393.75	44.50	1.00	73	-1.23	43.27	46.00	-2.73
528.34	38.88	1.00	29	3.62	42.50	46.00	-3.50
586.54	34.44	1.00	21	6.08	40.52	46.00	-5.48

Test mode: IEEE 802.11b CH11 for 30MHz to 1GHz [Vertical]

<i>Radiated Emission</i>				<i>Correction Factors</i>	<i>Corrected Amplitude</i>	<i>Class B (3 m)</i>	
<i>Frequency (MHz)</i>	<i>Amplitude (dBμV)</i>	<i>Ant. H. (m)</i>	<i>Table ()</i>			<i>Limit (dBμV/m)</i>	<i>Margin (dB)</i>
67.59	34.77	1.00	213	1.37	36.14	40.00	-3.86
90.00	33.94	1.00	52	0.01	33.95	43.50	-9.55
101.54	42.52	1.00	311	-0.73	41.79	43.50	-1.71
174.29	44.83	1.00	31	-4.05	40.78	43.50	-2.72
368.29	39.71	1.00	182	-1.83	37.88	46.00	-8.12
528.34	35.75	1.00	314	3.62	39.37	46.00	-6.63

Test mode: IEEE 802.11b CH11 for 1GHz to 25GHz [Horizontal]

Frequency	Ant. H.	Table	Amplitude		Correction Factor	Corrected Amplitude		Limit		Margin
			Peak / Ave.			Peak / Ave.		Peak / Ave.		
MHz	m	degree	dBµV		dB/m	dBµV/m		dBµV/m		dB
1641.32	1.00	184	39.66	35.33	13.69	53.35	49.02	73.96	53.96	-4.94
2154.15	1.00	211	48.66	30.83	8.52	57.18	39.35	73.96	53.96	-14.61
2550.00	1.00	12	38.50	---	9.58	48.08	---	73.96	53.96	-5.88
12308.75	1.00	324	37.94	---	9.56	47.50	---	73.96	53.96	-6.46
19696.46	1.00	219	45.49	---	1.81	47.30	---	73.96	53.96	-6.66
24619.37	1.00	59	46.41	---	3.01	49.42	---	73.96	53.96	-4.54

Test mode: IEEE 802.11b CH11 for 1GHz to 25GHz [Vertical]

Frequency	Ant. H.	Table	Amplitude		Correction Factor	Corrected Amplitude		Limit		Margin
			Peak / Ave.			Peak / Ave.		Peak / Ave.		
MHz	m	degree	dBµV		dB/m	dBµV/m		dBµV/m		dB
1641.32	1.00	280	40.66	34.83	13.69	54.35	48.52	73.96	53.96	-5.44
2152.76	1.00	163	48.82	38.50	8.52	57.34	47.02	73.96	53.96	-6.94
2560.42	1.00	159	39.34	---	9.60	48.94	---	73.96	53.96	-5.02
4925.83	1.00	151	45.44	---	4.13	49.57	---	73.96	53.96	-4.39
12308.75	1.00	223	40.94	---	9.56	50.50	---	73.96	53.96	-3.46
24619.37	1.00	66	46.51	---	3.01	49.52	---	73.96	53.96	-4.44

Test mode: IEEE 802.11g CH01 for 30MHz to 1GHz [Horizontal]

Radiated Emission				Correction Factors (dB)	Corrected Amplitude (dBμV/m)	Class B (3 m)	
Frequency (MHz)	Amplitude (dBμV)	Ant. H. (m)	Table ()			Limit (dBμV/m)	Margin (dB)
79.71	32.05	1.00	249	0.66	32.71	40.00	-7.29
107.60	38.30	1.00	201	-1.54	36.76	43.50	-6.74
120.94	38.18	1.00	201	-2.45	35.73	43.50	-7.77
367.07	45.76	1.00	35	-1.86	43.90	46.00	-2.10
382.84	43.08	1.00	73	-1.49	41.59	46.00	-4.41
528.34	38.57	1.00	32	3.62	42.19	46.00	-3.81

Test mode: IEEE 802.11g CH01 for 30MHz to 1GHz [Vertical]

Radiated Emission				Correction Factors (dB)	Corrected Amplitude (dBμV/m)	Class B (3 m)	
Frequency (MHz)	Amplitude (dBμV)	Ant. H. (m)	Table ()			Limit (dBμV/m)	Margin (dB)
90.62	34.65	1.00	17	-0.02	34.63	43.50	-8.87
10.54	37.46	1.00	0	-0.73	36.73	43.50	-6.77
134.27	36.82	1.00	55	-3.21	33.61	43.50	-9.89
181.56	37.15	1.00	45	-3.94	33.21	43.50	-10.29
528.34	34.73	1.00	324	3.62	38.35	46.00	-7.65
896.94	22.46	1.00	360	15.04	37.50	46.00	-8.50

Test mode: IEEE 802.11g CH01 for 1GHz to 25GHz [Horizontal]

Frequency	Ant. H.	Table	Amplitude		Correction Factor	Corrected Amplitude		Limit		Margin
			Peak / Ave.			Peak / Ave.		Peak / Ave.		
MHz	m	degree	dBµV		dB/m	dBµV/m		dBµV/m		dB
1607.99	1.00	238	40.16	32.67	14.21	54.37	46.88	73.96	53.96	-7.08
2110.02	1.00	349	43.33	22.67	8.40	51.73	31.07	73.96	53.96	-22.23
12061.04	1.00	254	37.94	---	9.81	47.75	---	73.96	53.96	-6.21
19296.25	1.00	258	46.29	---	1.60	47.89	---	73.96	53.96	-6.07
21708.12	1.00	176	44.75	---	2.87	47.62	---	73.96	53.96	-6.34
24120.00	1.00	264	44.58	---	3.40	47.98	---	73.96	53.96	-5.98

Test mode: IEEE 802.11g CH01 for 1GHz to 25GHz [Vertical]

Frequency	Ant. H.	Table	Amplitude		Correction Factor	Corrected Amplitude		Limit		Margin
			Peak / Ave.			Peak / Ave.		Peak / Ave.		
MHz	m	degree	dBµV		dB/m	dBµV/m		dBµV/m		dB
1608.01	1.00	241	37.66	29.67	14.21	51.87	43.88	73.96	53.96	-10.08
2102.08	1.00	343	41.66	---	8.38	50.04	---	73.96	53.96	-3.92
2243.75	1.00	330	41.34	---	8.77	50.11	---	73.96	53.96	-3.85
9650.42	1.00	35	34.77	---	11.47	46.24	---	73.96	53.96	-7.72
19296.25	1.00	254	46.62	---	1.60	48.22	---	73.96	53.96	-5.74
24120.00	1.00	247	44.76	---	3.40	48.16	---	73.96	53.96	-5.80

Test mode: IEEE 802.11g CH06 for 30MHz to 1GHz [Horizontal]

<i>Radiated Emission</i>				<i>Correction Factors</i>	<i>Corrected Amplitude</i>	<i>Class B (3 m)</i>	
<i>Frequency (MHz)</i>	<i>Amplitude (dBμV)</i>	<i>Ant. H. (m)</i>	<i>Table ()</i>			<i>Limit (dBμV/m)</i>	<i>Margin (dB)</i>
78.50	31.97	1.00	273	0.74	32.71	40.00	-7.29
122.15	39.35	1.00	225	-2.53	36.82	43.50	-6.68
365.86	42.41	1.00	62	-1.89	40.52	46.00	-5.48
370.71	44.04	1.00	194	-1.78	42.26	46.00	-3.74
528.34	37.71	1.00	39	3.62	41.33	46.00	-4.67
896.94	23.31	1.00	85	15.04	38.35	46.00	-7.65

Test mode: IEEE 802.11g CH06 for 30MHz to 1GHz [Vertical]

<i>Radiated Emission</i>				<i>Correction Factors</i>	<i>Corrected Amplitude</i>	<i>Class B (3 m)</i>	
<i>Frequency (MHz)</i>	<i>Amplitude (dBμV)</i>	<i>Ant. H. (m)</i>	<i>Table ()</i>			<i>Limit (dBμV/m)</i>	<i>Margin (dB)</i>
67.59	30.42	1.00	249	1.37	31.79	40.00	-8.21
86.99	34.00	1.00	42	0.20	34.20	40.00	-5.80
101.54	37.82	1.00	76	-0.73	37.09	43.50	-6.41
122.15	40.86	1.00	357	-2.53	38.33	43.50	-5.17
168.22	40.43	1.00	346	-4.10	36.33	43.50	-7.17
528.34	36.82	1.00	314	3.62	40.44	46.00	-5.56

Test mode: IEEE 802.11g CH06 for 1GHz to 25GHz [Horizontal]

Frequency	Ant. H.	Table	Amplitude		Correction Factor	Corrected Amplitude		Limit		Margin
			Peak / Ave.			Peak / Ave.		Peak / Ave.		
MHz	m	degree	dBμV		dB/m	dBμV/m		dBμV/m		dB
1624.67	1.00	310	37.66	30.33	13.95	51.61	44.28	73.96	53.96	-9.68
2152.64	1.00	232	43.66	30.67	8.52	52.18	39.19	73.96	53.96	-14.77
12187.92	1.00	254	38.44	---	9.74	48.18	---	73.96	53.96	-5.78
19498.12	1.00	209	46.83	---	1.70	48.53	---	73.96	53.96	-5.43
21934.79	1.00	194	45.89	---	3.09	48.98	---	73.96	53.96	-4.98
24371.46	1.00	219	45.88	---	3.26	49.14	---	73.96	53.96	-4.82

Test mode: IEEE 802.11g CH06 for 1GHz to 25GHz [Vertical]

Frequency	Ant. H.	Table	Amplitude		Correction Factor	Corrected Amplitude		Limit		Margin
			Peak / Ave.			Peak / Ave.		Peak / Ave.		
MHz	m	degree	dBμV		dB/m	dBμV/m		dBμV/m		dB
1624.66	1.00	225	39.82	30.50	13.95	53.77	44.45	73.96	53.96	-9.51
2159.14	1.00	161	44.48	28.50	8.54	53.02	37.04	73.96	53.96	-16.92
12187.92	1.00	343	39.60	---	9.74	49.34	---	73.96	53.96	-4.62
19498.12	1.00	210	47.09	---	1.70	48.79	---	73.96	53.96	-5.17
21934.79	1.00	195	45.89	---	3.09	48.98	---	73.96	53.96	-4.98
24371.46	1.00	217	45.57	---	3.26	48.83	---	73.96	53.96	-5.13

Test mode: IEEE 802.11g CH11 for 30MHz to 1GHz [Horizontal]

<i>Radiated Emission</i>				<i>Correction Factors</i>	<i>Corrected Amplitude</i>	<i>Class B (3 m)</i>	
<i>Frequency (MHz)</i>	<i>Amplitude (dBμV)</i>	<i>Ant. H. (m)</i>	<i>Table ()</i>			<i>Limit (dBμV/m)</i>	<i>Margin (dB)</i>
79.71	32.10	1.00	252	0.66	32.76	40.00	-7.24
122.15	41.89	1.00	91	-2.53	39.36	43.50	-4.14
362.22	44.35	1.00	49	-1.98	42.37	46.00	-3.63
370.71	43.18	1.00	63	-1.78	41.40	46.00	-4.60
528.34	37.97	1.00	36	3.62	41.59	46.00	-4.41
586.54	31.39	1.00	36	6.08	37.47	46.00	-8.53

Test mode: IEEE 802.11g CH11 for 30MHz to 1GHz [Vertical]

<i>Radiated Emission</i>				<i>Correction Factors</i>	<i>Corrected Amplitude</i>	<i>Class B (3 m)</i>	
<i>Frequency (MHz)</i>	<i>Amplitude (dBμV)</i>	<i>Ant. H. (m)</i>	<i>Table ()</i>			<i>Limit (dBμV/m)</i>	<i>Margin (dB)</i>
68.80	29.05	1.00	121	1.34	30.39	40.00	-9.61
74.86	29.96	1.00	280	0.98	30.94	40.00	-9.06
91.84	34.69	1.00	48	-0.09	34.60	43.50	-8.90
101.54	37.49	1.00	48	-0.73	36.76	43.50	-6.74
120.94	38.34	1.00	145	-2.45	35.89	43.50	-7.61
528.34	34.90	1.00	314	3.62	38.52	46.00	-7.48

Test mode: IEEE 802.11g CH11 for 1GHz to 25GHz [Horizontal]

Frequency	Ant. H.	Table	Amplitude		Correction Factor	Corrected Amplitude		Limit		Margin
			Peak / Ave.			Peak / Ave.		Peak / Ave.		
MHz	m	degree	dBμV		dB/m	dBμV/m		dBμV/m		dB
1641.33	1.00	234	40.49	32.67	13.69	54.18	46.36	73.96	53.96	-7.60
2154.18	1.00	354	51.82	30.33	8.52	60.34	38.85	73.96	53.96	-13.62
12308.75	1.00	194	36.77	---	9.56	46.33	---	73.96	53.96	-7.63
19696.46	1.00	292	45.08	---	1.81	46.89	---	73.96	53.96	-7.07
22157.92	1.00	137	44.04	---	3.25	47.29	---	73.96	53.96	-6.67
24619.37	1.00	209	45.56	---	3.01	48.57	---	73.96	53.96	-5.39

Test mode: IEEE 802.11g CH11 for 1GHz to 25GHz [Vertical]

Frequency	Ant. H.	Table	Amplitude		Correction Factor	Corrected Amplitude		Limit		Margin
			Peak / Ave.			Peak / Ave.		Peak / Ave.		
MHz	m	degree	dBμV		dB/m	dBμV/m		dBμV/m		dB
1641.33	1.00	339	40.49	31.17	13.69	54.18	44.86	73.96	53.96	-9.10
2152.08	1.00	101	41.50	---	8.52	50.02	---	73.96	53.96	-3.94
12308.75	1.00	252	37.27	---	9.56	46.83	---	73.96	53.96	-7.13
19696.46	1.00	200	45.62	---	1.81	47.43	---	73.96	53.96	-6.53
22157.92	1.00	143	43.78	---	3.25	47.03	---	73.96	53.96	-6.93
24619.37	1.00	61	46.12	---	3.01	49.13	---	73.96	53.96	-4.83

5.4 Test Result of the Bandedge

If any 100 kHz bandwidth outside these frequency bands, the radio frequency power that is produced by the modulation products of the spreading sequence, the information sequence and the carrier frequency shall be either *at least 20 dB below that in any 100 kHz bandwidth within the band that contains the highest level of the desired power or shall not exceed the general levels specified in §15.209(a)*,

We perform this section by the *radiated manner*, the RBW is set to 100kHz and $VBW > RBW$. We'd made the observation *up to 10th harmonics and the criterion is all the harmonic/spurious emissions must be 20dB below the highest emission level measured*. If the emissions fall in the restricted bands stated in the Part 15.205(a) must also *comply with the radiated emission limits specified in Part 15.209(a)*. (*Peak mode: $RBW=VBW=1MHz$, Average mode: $RBW=1MHz$; $VBW=10Hz$*)

The following pages show our observations referring to the channel 1 and 11 respectively.

Test Condition & Setup: same as < 8.1 >

IEEE 802.11b Ch01

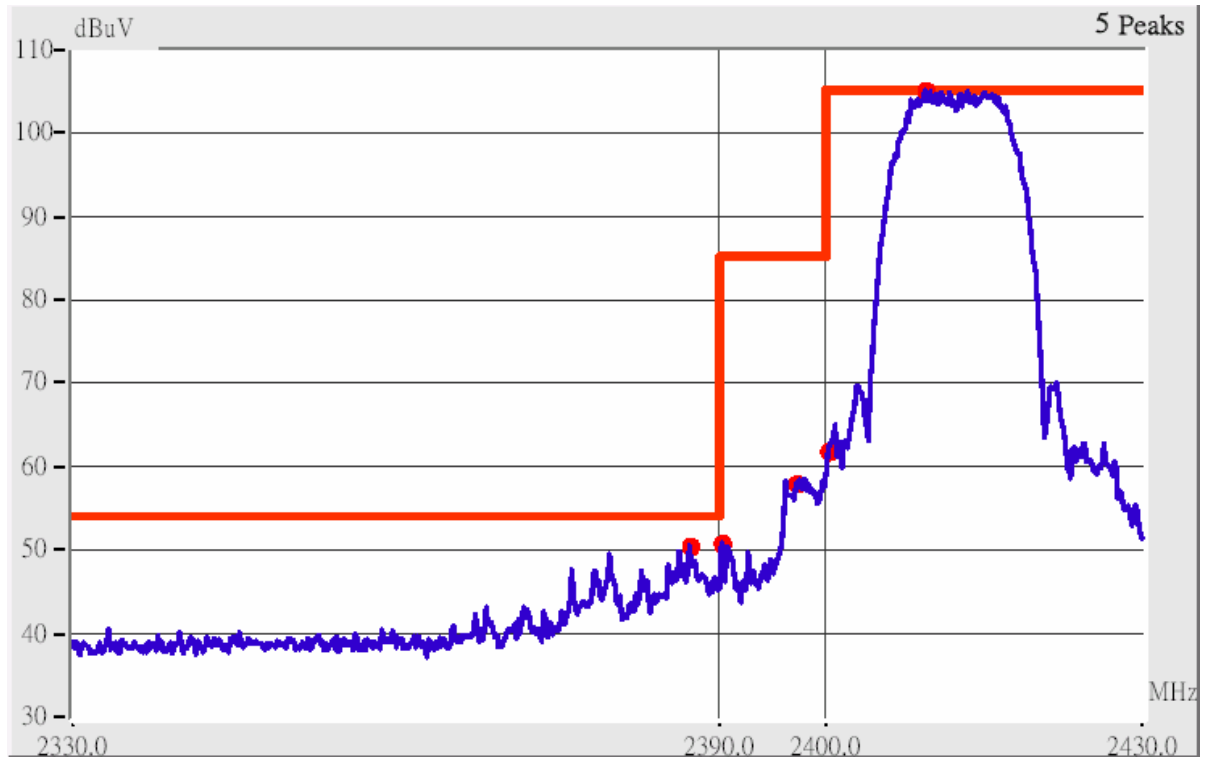

This is the hard copy of our bandedge measurement generated by our bandedge testing program. The plot shown above is the bandedge of channel 1.

1. The lobe left by the fundamental side is already 20dB below the highest emission level.
2. The emissions recorded in the restricted band is do comply with the Part 15.209(a) – as below.

Radiated Emission					Corrected Amplitude		Class B (3m)		
Frequency (MHz)	Ant. P.	Ant. H. (m)	Angle (°)	Factors (dB)	(dBµV/m)		Limit (dBµV/m)		Margin (dB)
					Peak	Average	Peak	Ave.	
2385.53	Hor	1.00	204	9.17	58.17	43.00	73.96	53.96	-10.96
2389.99	Hor	1.00	194	9.18	58.52	43.51	73.96	53.96	-10.45
2385.97	Ver	1.00	95	9.17	58.67	43.34	73.96	53.96	-10.62
2390.01	Ver	1.00	136	9.18	59.68	43.18	73.96	53.96	-10.78

IEEE 802.11b Ch11

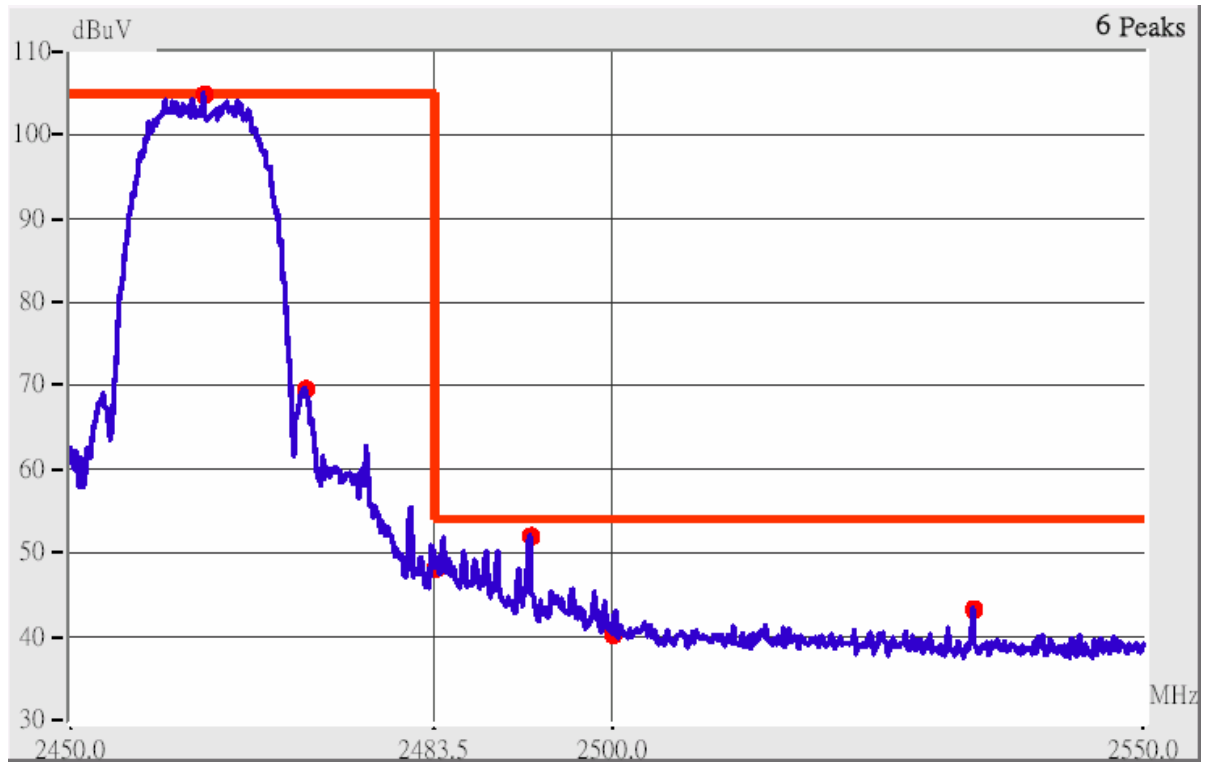

This is the hard copy of our bandedge measurement generated by our bandedge testing program. The plot shown above is the bandedge of channel 11.

- 3. The lobe right by the fundamental side is already 20dB below the highest emission level.
- 4. The emissions recorded in the restricted band is do comply with the Part 15.209(a) – as below

Radiated Emission					Corrected Amplitude		Class B (3m)		
Frequency (MHz)	Ant. P.	Ant. H. (m)	Angle (°)	Factors (dB)	(dBµV/m)		Limit (dBµV/m)		Margin (dB)
					Peak	Average	Peak	Ave.	
2483.19	Hor	1.00	178	9.44	55.94	43.44	73.96	53.96	-10.52
2487.99	Hor	1.00	303	9.46	58.62	43.46	73.96	53.96	-10.50
2500.01	Hor	1.00	297	9.49	50.16	---	73.96	53.96	-3.80
2506.83	Hor	1.00	295	9.50	49.67	---	73.96	53.96	-4.29
2483.99	Ver	1.00	98	9.45	58.61	44.95	73.96	53.96	-9.01
2486.98	Ver	1.00	99	9.45	59.62	43.78	73.96	53.96	-10.18
2500.00	Ver	1.00	350	9.49	51.66	38.49	73.96	53.96	-15.47
2505.08	Ver	1.00	232	9.50	53.17	38.83	73.96	53.96	-16.13

IEEE 802.11g Ch01

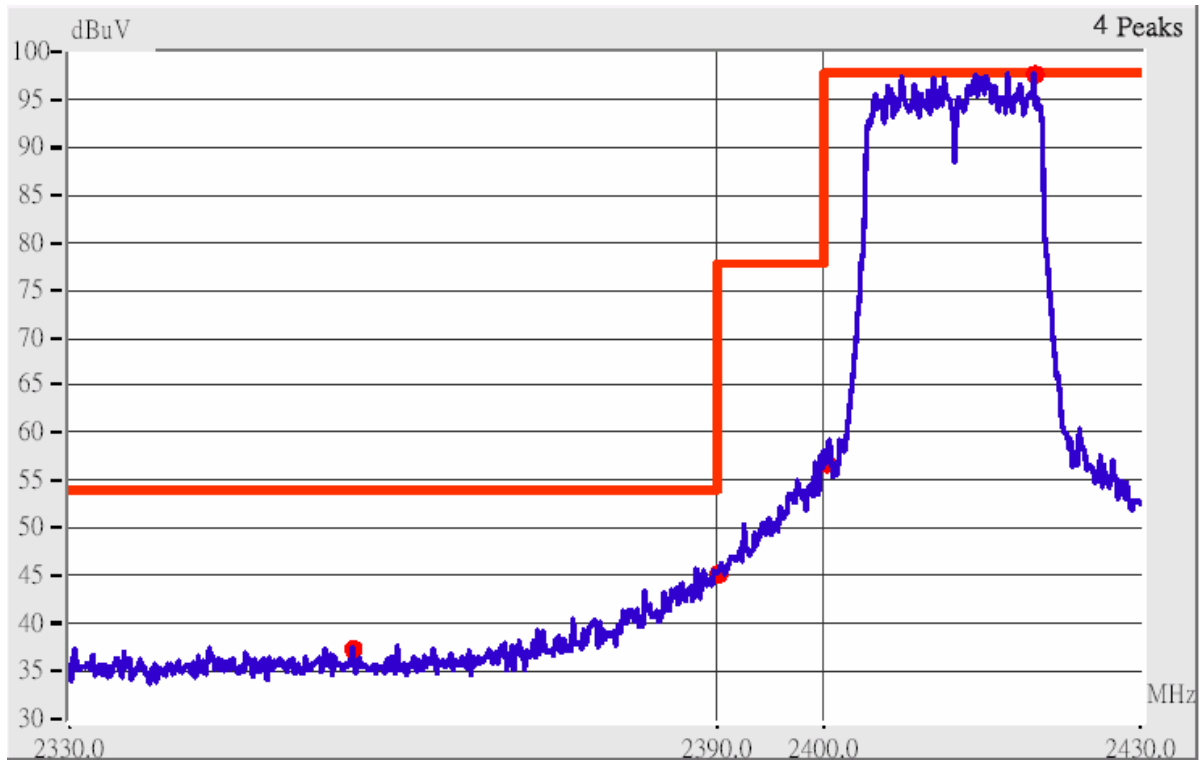

This is the hard copy of our bandedge measurement generated by our bandedge testing program. The plot shown above is the bandedge of channel 1.

- 5. The lobe left by the fundamental side is already 20dB below the highest emission level.
- 6. The emissions recorded in the restricted band is do comply with the Part 15.209(a) – as below.

<i>Radiated Emission</i>					<i>Corrected Amplitude</i>		<i>Class B (3m)</i>		
<i>Frequency (MHz)</i>	<i>Ant. P.</i>	<i>Ant. H. (m)</i>	<i>Angle (°)</i>	<i>Factors (dB)</i>	<i>(dBµV/m)</i>		<i>Limit (dBµV/m)</i>		<i>Margin (dB)</i>
					<i>Peak</i>	<i>Average</i>	<i>Peak</i>	<i>Ave.</i>	
2383.62	Hor	1.00	182	9.16	50.66	---	73.96	53.96	-3.30
2389.83	Hor	1.00	173	9.18	54.18	36.18	73.96	53.96	-17.78
2386.33	Ver	1.00	5	9.17	54.84	35.84	73.96	53.96	-18.12
2390.10	Ver	1.00	224	9.18	57.35	37.18	73.96	53.96	-16.61

IEEE 802.11g Ch11

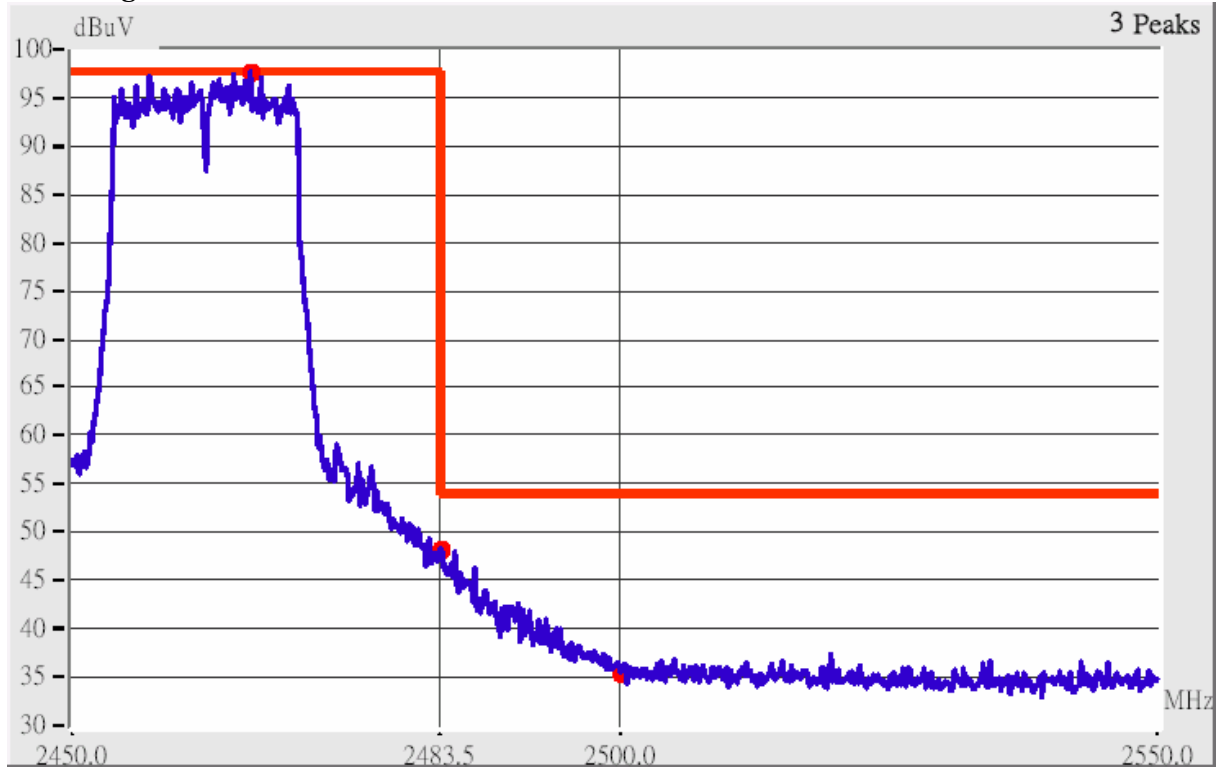

This is the hard copy of our bandedge measurement generated by our bandedge testing program. The plot shown above is the bandedge of channel 11.

- 7. The lobe right by the fundamental side is already 20dB below the highest emission level.
- 8. The emissions recorded in the restricted band is do comply with the Part 15.209(a) – as below

Radiated Emission					Corrected Amplitude		Class B (3m)		
Frequency (MHz)	Ant. P.	Ant. H. (m)	Angle (°)	Factors (dB)	(dBµV/m)		Limit (dBµV/m)		Margin (dB)
					Peak	Average	Peak	Ave.	
2483.18	Hor	1.00	243	9.44	55.44	37.27	73.96	53.96	-16.69
2485.79	Hor	1.00	240	9.45	56.95	36.62	73.96	53.96	-17.01
2499.95	Hor	1.00	230	9.49	49.99	---	73.96	53.96	-3.97
2517.97	Hor	1.00	94	9.52	45.69	---	73.96	53.96	-8.27
2482.98	Ver	1.00	237	9.44	57.44	37.44	73.96	53.96	-16.52
2485.16	Ver	1.00	281	9.45	56.95	36.62	73.96	53.96	-17.01
2500.01	Ver	1.00	139	9.49	47.49	---	73.96	53.96	-6.47
2509.40	Ver	1.00	283	9.51	46.34	---	73.96	53.96	-7.62