

# MEASUREMENT REPORT of *WIFI module*

**Applicant** : PEGATRON CORPORATION  
**EUT** : WIFI Module  
**Model No.** : UPWL6013  
**FCC ID** : VUI-UPWL6013

Tested by :

*Training Research Co., Ltd.*

**TEL : 886-2-26935155**      **FAX : 886-2-26934440**

No. 255, Nanyang Street, Shijr, Taipei Hsien 221, Taiwan, R.O.C.

# CERTIFICATION

**We here by verify that:**

The test data, data evaluation, test procedures and equipment configurations shown in this report were made mainly in accordance with the procedures given in ANSI C63.4 (2003) as a reference. All test were conducted by *Training Research Co., Ltd.*, 255 Nanyang Street, Shijr, Taipei Hsien 221, Taiwan, R.O.C. Also, we attest to the accuracy of each.

We further submit that the energy emitted by the sample EUT tested as described in the report is **in compliance with** the technical requirements set forth in the FCC Rules Part 15 Subpart C Section 15.247.

**Applicant** : PEGATRON CORPORATION  
**Applicant Address** : 5F, NO. 76, LIGONG ST., BEITOU DISTRICT,  
TAIPEI CITY, TAIWAN  
**FCC ID** : VUI-UPWL6013  
**Report No.** : P5515110114  
**Test Date** : November 02, 2011 ~ December 09, 2011

Prepared by:   
Jack Tsai

Approved by:   
Frank Tsai

**Conditions of issue :**

- (1) **This test report shall not be reproduced except in full, without written approval of TRC. And the test result contained within this report only relate to the sample submitted for testing.**

## *Tables of Contents*

<b>I. GENERAL</b> .....	5
1.1 Introduction .....	5
1.2 Description of EUT .....	5
1.3 Test method .....	5
1.4 Description of Support Equipment .....	6
1.5 Configuration of System Under Test .....	7
1.6 Verify the Frequency and Channel .....	8
1.7 Test Procedure .....	9
1.8 Location of the Test Site .....	9
1.9 General Test Condition .....	9
<b>II. Section 15.203 : Antenna Requirement</b> .....	10
<b>III. Section 15.207 : Power Line Conducted Emissions for AC Powered Units</b> .....	11
3.1 Test Condition & Setup .....	11
3.2 List of Test Instruments .....	12
3.3 Test Result of Conducted Emissions .....	13
IEEE 802.11b .....	13
IEEE 802.11g .....	15
IEEE 802.11n 20M .....	16
<b>IV. Section 15.247(a) : Technical Description of the EUT</b> .....	18
<b>V. Section 15.247(a)(2) : Bandwidth for Direct Sequence System</b> .....	19
5.1 Test Condition & Setup .....	19
5.2 Test Instruments Configuration .....	19
5.3 List of Test Instruments .....	19
5.4 Test Result of Bandwidth .....	20
IEEE 802.11b mode .....	21
IEEE 802 11g mode .....	22
IEEE 802 11n 20M mode .....	24

- VI. Section 15.247(b) : Power Output** ..... 26
  - 6.1 Test Condition & Setup ..... 26
  - 6.2 List of Test Instruments ..... 26
  - 6.3 Test Result ..... 26
  
- VII. Section 15.247(c) : Spurious Emissions (Radiated)** ..... 28
  - 7.1 Test Condition & Setup ..... 28
  - 7.2 List of Test Instruments ..... 30
  - 7.3 Test Result of Spurious Radiated Emissions ..... 31
    - IEEE 802.11b mode ..... 31
    - IEEE 802 11g mode ..... 38
    - IEEE 802 11n 20M mode ..... 44
  - 7.4 Test Result of Bandedge..... 50
    - IEEE 802.11b mode ..... 51
    - IEEE 802 11g mode ..... 53
    - IEEE 802 11n 20M mode ..... 55
  
- VIII. Section 15.247(d) : Power Spectral Density** ..... 57
  - 8.1 Test Condition & Setup ..... 57
  - 8.2 Test Instruments Configuration ..... 57
  - 8.3 List of Test Instruments..... 57
  - 8.4 Test Result of Power Spectral Density ..... 58
    - IEEE 802.11b mode ..... 59
    - IEEE 802.11g mode ..... 60
    - IEEE 802.11n 20M mode ..... 62

## **I . GENERAL**

### **1.1 Introduction**

The following measurement report is submitted on behalf of applicant in support that the certification in accordance with Part 2 Subpart J and Part 15 Subpart A, B and C of the Commission's Rules and Regulations.

### **1.2 Description of EUT**

<b>FCC ID</b>	:	VUI-UPWL6013
<b>Product Name</b>	:	WIFI Module
<b>Model Name</b>	:	UPWL6013
<b>Frequency Range</b>	:	IEEE 802.11b/g/n Draft 1.0 20M: 2.412GHz ~ 2.462GHz
<b>Channel Spacing</b>	:	5MHz
<b>Support Channel</b>	:	IEEE 802.11b/g/n Draft 1.0 20M: 11 Channels
<b>Modulation Skill</b>	:	DBPSK, DQPSK, CCK, OFDM
<b>Power Type</b>	:	Powered by PCI Express interface of client's device

### **1.3 Test method**

- 1.3.1 Insert the EUT into the PCI Express interface of extend card of the test fixture.
- 1.3.2 Using the computer and software provided by the manufacturer to control EUT. The software is operated under the Windows to control the EUT in the mode of continuous transmission; the test is performed under the specific conditions.
- 1.3.3 Set different data rate and channel (IEEE 802.11b/g/n Draft 1.0 20M: CH01/CH06/CH11) being tested and repeat the procedures above.
  - (a) Conducted test and Radiated test:
    - making EUT to the continuously (TX) mode.

### 1.4 Description of Support Equipment

In order to construct the minimum testing, following equipment were used as the support units.

**Notebook** : **DELL**  
Model No. : JX285 (PP26L)  
Serial No. : 410362204  
FCC ID : Doc Approved  
BSMI : R33002

**Power Adaptor** : **DELL**  
Model No. : LA65NS1-00  
Part No. : PA-1650-05D3  
Serial No. : CN-0YD637-716145-82T-0B8F  
FCC ID : Doc Approved  
BSMI : R33275  
Power type : 100 ~ 240VAC / 50 – 60Hz, 1.5A, Switching  
Power cord (Main power to adaptor): Non-shielded, 0.90m length, Plastic hood, No ferrite core  
Power cord (DC plug to adaptor): Shielded, 1.83m length, Plastic hood, ferrite core

#### Test fixture

**(PCI Express Extend Card):PEGATRON CORPORATION**

Model No. : ADC-PEMCCC01  
Serial No. : N/A  
Power type : By NB

**1.5 Configuration of System Under Test**

**1.5.1 Conducted and Radiated Emission Test**

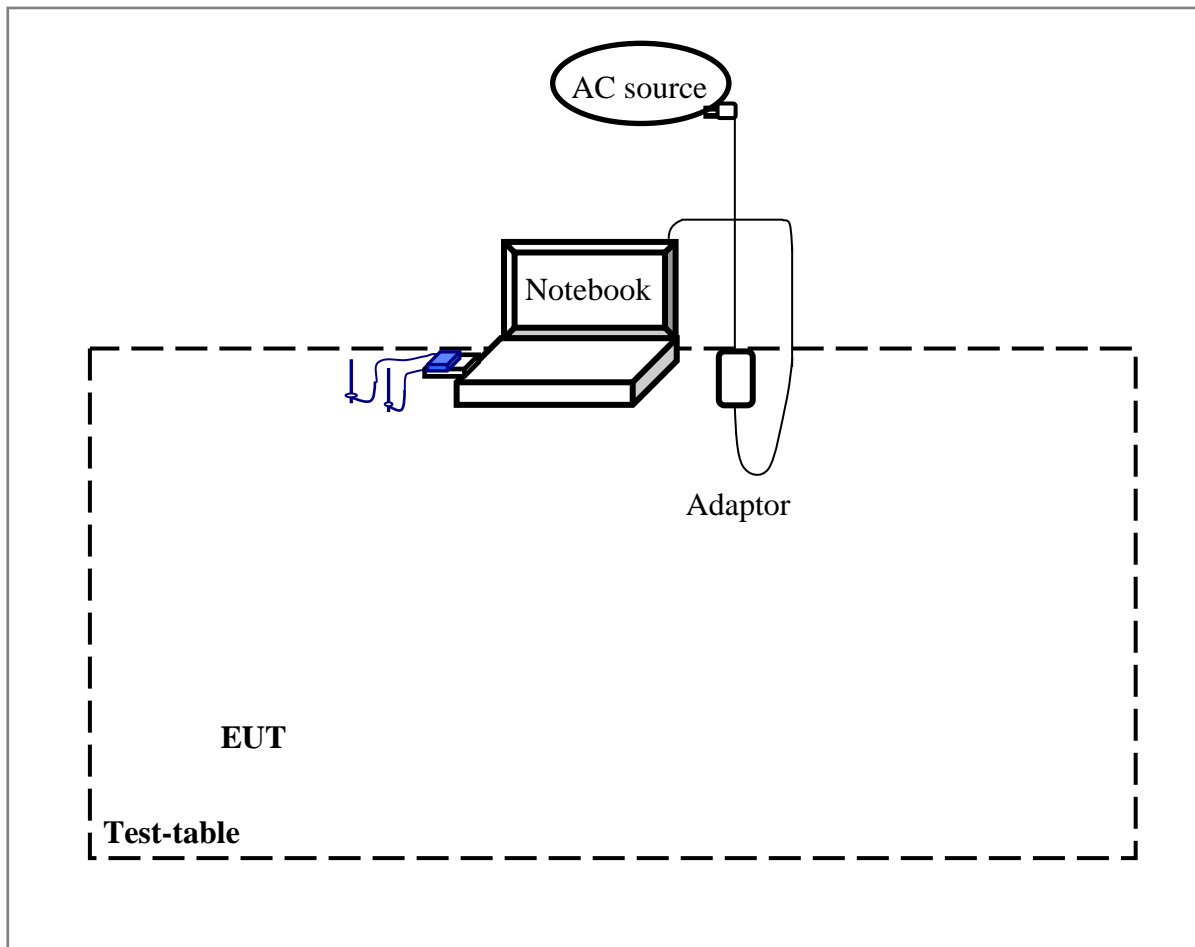

**Notebook PC:**

\*Mini-PCI Port ..... EUT

The tests below are carried with the EUT transmitter set at high power in TDD mode. The EUT is forced to select of output power level and channel number by USB port.

The setting up procedure was recorded in 1.3 test method.

**1.6 Verify the Frequency and Channel**

Channel	Frequency (GHz)
1	2.412
2	2.417
3	2.422
4	2.427
5	2.432
6	2.437
7	2.442
8	2.447
9	2.452
10	2.457
11	2.462

Note:

1. This is for confirming that all frequencies of IEEE 802.11b/g/n Draft 1.0 20M are in 2.412GHz to 2.462GHz..
2. Section 15.31(m): Measurements on intentional radiators or receivers shall be performed at three frequencies for operating frequency range over 10 MHz  
(The locations of these frequencies one near the top, one near the middle and one near the bottom.)
3. After test, the EUT operating frequencies are in 2.412GHz to 2.462GHz and. So all the items as followed in testing report are need to test these three frequencies: IEEE 802.11b/g/n Draft 1.0 20M: CH01/CH06/CH11



### **1.7 Test Procedure**

All measurements contained in this report were performed mainly according to the techniques described in ANSI C63.4 (2003) and the pre-setup was written on 1.3 test method, the detail setup was written on each test item.

### **1.8 Location of the Test Site**

The radiated emissions measurements required by the rules were performed on the **three-meter, Semi-anechoic Chamber (FCC Registration Number: 93906)** maintained by *Training Research Co., Ltd.* 1F, No. 255 Nanyang Street, Shijr, Taipei Hsien 221, Taiwan, R.O.C. Complete description and measurement data have been placed on file with the commission. The conducted power line emissions tests and other test items were performed in a semi-anechoic chamber also located at Training Research Co., Ltd.

No. 255 Nanyang Street, Shijr, Taipei Hsien 221, Taiwan, R.O.C. *Training Research Co., Ltd.* Is listed by the FCC as a facility available to do measurement work for others on a contract basis.

### **1.9 General Test Condition**

The conditions under which the EUT operates were varied to determine their effect on the equipment's emission characteristics. The final configuration of the test system and the mode of operation used during these tests were chosen as that which produced the highest emission levels. However, only those conditions, which the EUT was considered likely to encounter in normal use were investigated.

In test, they were set in high power and continuously transmitting mode that controlled by computer. The ch01, ch06 and ch11 of EUT were all tested. The setting up procedure is recorded on 1.3 test method.

## II. Section 15.203: Antenna requirement

The EUT can be equipped with detachable antenna. The external antenna is affixed to the EUT using a unique connector. The antenna requirement stated in Section 15.203 is inapplicable to this EUT.

The antenna specification of list as follows,

Antenna No.	Antenna Manufacturer	Model	Connector	Antenna Type	Antenna Gain (Max.)
Antenna #1	WHAYU	C1335-520153-A & C1335-520154-A	MHF	PIFA	5.73 dBi
Antenna #2	CHANGSHU HONGLIN	260-23197 & 260-23198	MHF	PIFA	2.94 dBi

Note:

- 1) For more detailed features description, please reference to the Antenna Specifications. (Please reference to RF Exposure Information)
- 2) We select three kinds antenna including **antenna #1**, and **antenna #2** which apply to conduction and radiated emission.
- 3) The conduction and radiated emissions data presented the worst case of the **antenna #1** supplied with the EUT.

### **III. Section 15.207: Power Line Conducted Emissions for AC Powered Units**

#### **3.1 Test Condition & Setup**

The power line conducted emission measurements were performed in an semi-anechoic chamber. The EUT was assembled on a wooden table, which is 80 centimeters high, was placed 40 centimeters from the backwall and at least 1 meter from the sidewall.

Power was fed to the EUT from the public utility power grid through a line filter and Line Impedance Stabilization Networks (LISNs). The LISN housing, measuring instrumentation case, ground plane, etc., were electrically bonded together at the same RF potential. The Spectrum analyzer (or EMI receiver) was connected to the AC line through an isolation transformer. The 50-ohm output of the LISN was connected to the spectrum analyzer directly. Conducted emission levels were in the CISPR quasi-peak and average detection mode. The analyzer's 6 dB bandwidth was set to 9 KHz. No post-detector video filter was used.

The spectrum was scanned from 150 KHz to 30 MHz. The physical arrangement of the test system and associated cabling was varied (within the scope of arrangements likely to be encountered in actual use) to determine the effect on the unit's emanations in amplitude and frequency. All spurious emission frequencies were observed. The highest emission amplitudes relative to the appropriate limit were measured and have been recorded in paragraph 4.3

There is a test condition apply in this test item, the test procedure description as <1.3>. Three channels were tested, one in the top, one in the middle and the other in bottom.

**3.2 List of Test Instruments**

Instrument Name	Model	Brand	Serial No.	Calibration Date
				Next time
EMI Receiver	8546A	HP	3520A00242	03/12/12
RF Filter Section	85460A	HP	3448A00217	03/12/12
LISN (EUT)	3816/2	EMCO	00042976	02/10/12
LISN (Support E.)	3816/2	EMCO	00042989	01/26/12
Coaxial Cable (2.0 meter)	A30A30-0058-50FS-2M	Jyebao	SMA-08	04/06/12
Coaxial Cable (1.1 meter)	A30A30-0058-50FS-1M	Jyebao	SMA-09	04/06/12
Coaxial Cable (20 meter)	RG-214/U	Jyebao	NP-01	04/06/12
Coaxial Cable (20 meter)	RG-214/U	Jyebao	NP-02	04/06/12
Auto Switch Box (< 30MHz)	ASB-01	TRC	9904-01	04/06/12

### 3.3 Test Result of Power Line Conducted Emissions

The following table shows a summary of the highest emissions of power line conducted emissions on the LIVE and NETURAL conductors of the EUT power cord. Show as follows.

Test Conditions: Temperature : 25 °C Humidity : 73 % RH

Test mode: IEEE 802.11b Channel 1

<i>Power Connected Emissions</i>					<i>Class B</i>		
<i>Conductor</i>	<i>Frequency (KHz)</i>	<i>Peak (dBµV)</i>	<i>QP (dBµV)</i>	<i>Average (dBµV)</i>	<i>QP-limit (dBµV)</i>	<i>AVG-limit (dBµV)</i>	<i>Margin (dB)</i>
Line 1	177.000	51.97	---	---	65.23	55.23	-3.26
	238.000	44.61	---	---	63.49	53.49	-8.88
	2072.000	38.48	---	---	56.00	46.00	-7.52
	2308.000	38.21	---	---	56.00	46.00	-7.79
	3477.000	38.00	---	---	56.00	46.00	-8.00
	3858.000	40.21	---	---	56.00	46.00	-5.79
Line 2	177.900	53.80	51.15	43.77	65.23	55.23	-11.46
	236.000	44.32	---	---	63.54	53.54	-9.22
	1534.000	36.15	---	---	56.00	46.00	-9.85
	1836.000	38.04	---	---	56.00	46.00	-7.96
	2372.000	36.47	---	---	56.00	46.00	-9.53
	3959.170	50.04	46.36	27.32	56.00	46.00	-9.64

NOTE:

- (1)Margin = Peak Amplitude – Limit, *The reading amplitudes are all under limit.*
- (2)A "+" sign in the margin column means the emission is OVER the Class B Limit and "-" sign of means UNDER the Class B limit

**Test mode: IEEE 802.11b Channel 6**

<b>Power Connected Emissions</b>					<b>Class B</b>		
<b>Conductor</b>	<b>Frequency (KHz)</b>	<b>Peak (dBµV)</b>	<b>QP (dBµV)</b>	<b>Average (dBµV)</b>	<b>QP-limit (dBµV)</b>	<b>AVG-limit (dBµV)</b>	<b>Margin (dB)</b>
Line 1	177.000	51.06	---	---	65.23	55.23	-4.17
	1645.000	37.54	---	---	56.00	46.00	-8.46
	2012.000	37.58	---	---	56.00	46.00	-8.42
	2351.000	39.69	---	---	56.00	46.00	-6.31
	3574.000	38.33	---	---	56.00	46.00	-7.67
	3947.420	46.91	44.32	27.46	56.00	46.00	-11.68
Line 2	174.000	49.31	---	---	65.31	55.31	-6.00
	1534.000	36.95	---	---	56.00	46.00	-9.05
	1696.000	35.94	---	---	56.00	46.00	-10.06
	1941.000	36.94	---	---	56.00	46.00	-9.06
	3819.000	42.13	---	---	56.00	46.00	-3.87
	5360.000	41.39	---	---	60.00	50.00	-8.61

**Test mode: IEEE 802.11b Channel 11**

<b>Power Connected Emissions</b>					<b>Class B</b>		
<b>Conductor</b>	<b>Frequency (KHz)</b>	<b>Peak (dBµV)</b>	<b>QP (dBµV)</b>	<b>Average (dBµV)</b>	<b>QP-limit (dBµV)</b>	<b>AVG-limit (dBµV)</b>	<b>Margin (dB)</b>
Line 1	174.000	48.07	---	---	65.31	55.31	-7.24
	1766.000	38.34	---	---	56.00	46.00	-7.66
	1941.000	38.79	---	---	56.00	46.00	-7.21
	2115.000	38.57	---	---	56.00	46.00	-7.43
	4571.000	38.79	---	---	56.00	46.00	-7.21
	5290.000	42.64	---	---	60.00	50.00	-7.36
Line 2	179.000	49.31	---	---	65.17	55.17	-5.86
	2012.000	36.99	---	---	56.00	46.00	-9.01
	2158.000	37.02	---	---	56.00	46.00	-8.98
	3285.000	38.49	---	---	56.00	46.00	-7.51
	3975.000	39.96	---	---	56.00	46.00	-6.04
	4292.115	43.96	39.31	23.15	56.00	46.00	-16.69

*Test mode: IEEE 802.11g Channel 1*

<i>Power Connected Emissions</i>					<i>Class B</i>		
<i>Conductor</i>	<i>Frequency (KHz)</i>	<i>Peak (dBμV)</i>	<i>QP (dBμV)</i>	<i>Average (dBμV)</i>	<i>QP-limit (dBμV)</i>	<i>AVG-limit (dBμV)</i>	<i>Margin (dB)</i>
Line 1	177.000	51.22	---	---	65.23	55.23	-4.01
	1645.000	38.25	---	---	56.00	46.00	-7.75
	1871.000	40.00	---	---	56.00	46.00	-6.00
	2115.000	40.35	---	---	56.00	46.00	-5.65
	3574.000	38.72	---	---	56.00	46.00	-7.28
	3992.890	46.77	44.64	24.17	56.00	46.00	-11.36
Line 2	175.000	47.70	---	---	65.29	55.29	-7.59
	231.000	44.43	---	---	63.69	53.69	-9.26
	1818.000	37.50	---	---	56.00	46.00	-8.50
	3741.000	41.16	---	---	56.00	46.00	-4.84
	3936.000	41.97	---	---	56.00	46.00	-4.03
	4857.000	38.43	---	---	56.00	46.00	-7.57

*Test mode: IEEE 802.11g Channel 6*

<i>Power Connected Emissions</i>					<i>Class B</i>		
<i>Conductor</i>	<i>Frequency (KHz)</i>	<i>Peak (dBμV)</i>	<i>QP (dBμV)</i>	<i>Average (dBμV)</i>	<i>QP-limit (dBμV)</i>	<i>AVG-limit (dBμV)</i>	<i>Margin (dB)</i>
Line 1	177.000	49.45	---	---	65.23	55.23	-5.78
	1464.000	37.49	---	---	56.00	46.00	-8.51
	1924.000	40.15	---	---	56.00	46.00	-5.85
	3780.000	41.26	---	---	56.00	46.00	-4.74
	4210.000	39.54	---	---	56.00	46.00	-6.46
	5340.000	41.16	---	---	60.00	50.00	-8.84
Line 2	175.000	46.76	---	---	65.29	55.29	-8.53
	1645.000	37.14	---	---	56.00	46.00	-8.86
	1748.000	35.91	---	---	56.00	46.00	-10.09
	3580.485	45.32	41.55	23.32	56.00	46.00	-14.45
	3936.000	42.16	---	---	56.00	46.00	-3.84
	5390.000	41.42	---	---	60.00	50.00	-8.58

*Test mode: IEEE 802.11g Channel 11*

<i>Power Connected Emissions</i>					<i>FCC Class B</i>		
<i>Conductor</i>	<i>Frequency (KHz)</i>	<i>Peak (dBµV)</i>	<i>QP (dBµV)</i>	<i>Average (dBµV)</i>	<i>QP-limit (dBµV)</i>	<i>AVG-limit (dBµV)</i>	<i>Margin (dB)</i>
Line 1	175.000	47.49	---	---	65.29	55.29	-7.80
	233.000	44.10	---	---	63.63	53.63	-9.53
	1696.000	36.99	---	---	56.00	46.00	-9.01
	1924.000	40.29	---	---	56.00	46.00	-5.71
	3574.000	36.60	---	---	56.00	46.00	-9.40
	4092.000	39.41	---	---	56.00	46.00	-6.59
Line 2	177.000	46.92	---	---	65.23	55.23	-8.31
	1645.000	35.94	---	---	56.00	46.00	-10.06
	1924.000	36.54	---	---	56.00	46.00	-9.46
	3317.000	41.66	---	---	56.00	46.00	-4.34
	3757.805	47.48	44.36	26.87	56.00	46.00	-11.64
	4053.000	42.72	---	---	56.00	46.00	-3.28

*Test mode: IEEE 802.11n 20M Channel 1*

<i>Power Connected Emissions</i>					<i>Class B</i>		
<i>Conductor</i>	<i>Frequency (KHz)</i>	<i>Peak (dBµV)</i>	<i>QP (dBµV)</i>	<i>Average (dBµV)</i>	<i>QP-limit (dBµV)</i>	<i>AVG-limit (dBµV)</i>	<i>Margin (dB)</i>
Line 1	174.000	45.40	---	---	65.31	55.31	-9.91
	1871.000	38.19	---	---	56.00	46.00	-7.81
	2115.000	38.17	---	---	56.00	46.00	-7.83
	3702.000	36.82	---	---	56.00	46.00	-9.18
	4053.000	42.38	---	---	56.00	46.00	-3.62
	5210.000	40.19	---	---	60.00	50.00	-9.81
Line 2	177.000	47.61	---	---	65.23	55.23	-7.62
	233.000	43.37	---	---	63.63	53.63	-10.26
	1582.000	35.07	---	---	56.00	46.00	-10.93
	3522.065	45.68	39.44	20.45	56.00	46.00	-16.56
	3817.815	48.78	43.06	25.96	56.00	46.00	-12.94
	4092.000	42.70	---	---	56.00	46.00	-3.30



*Test mode: IEEE 802.11n 20M Channel 6*

<i>Power Connected Emissions</i>					<i>Class B</i>		
<i>Conductor</i>	<i>Frequency (KHz)</i>	<i>Peak (dBµV)</i>	<i>QP (dBµV)</i>	<i>Average (dBµV)</i>	<i>QP-limit (dBµV)</i>	<i>AVG-limit (dBµV)</i>	<i>Margin (dB)</i>
Line 1	152.000	48.18	---	---	65.94	55.94	-7.76
	1871.000	38.02	---	---	56.00	46.00	-7.98
	3317.000	37.17	---	---	56.00	46.00	-8.83
	3819.000	40.51	---	---	56.00	46.00	-5.49
	4053.000	39.92	---	---	56.00	46.00	-6.08
	4327.000	39.89	---	---	56.00	46.00	-6.11
Line 2	179.000	47.10	---	---	65.17	55.17	-8.07
	3221.000	39.96	---	---	56.00	46.00	-6.04
	3445.000	42.42	---	---	56.00	46.00	-3.58
	3582.310	46.72	39.54	22.48	56.00	46.00	-16.46
	3670.310	42.31	---	---	56.00	46.00	-3.69
	4053.000	42.28	---	---	56.00	46.00	-3.72

*Test mode: IEEE 802.11n 20M Channel 11*

<i>Power Connected Emissions</i>					<i>Class B</i>		
<i>Conductor</i>	<i>Frequency (KHz)</i>	<i>Peak (dBµV)</i>	<i>QP (dBµV)</i>	<i>Average (dBµV)</i>	<i>QP-limit (dBµV)</i>	<i>AVG-limit (dBµV)</i>	<i>Margin (dB)</i>
Line 1	150.000	47.72	---	---	66.00	56.00	-8.28
	163.000	48.14	---	---	65.63	55.63	-7.49
	177.000	45.75	---	---	65.23	55.23	-9.48
	2115.000	37.82	---	---	56.00	46.00	-8.18
	3702.000	40.91	---	---	56.00	46.00	-5.09
	4762.000	39.25	---	---	56.00	46.00	-6.75
Line 2	175.000	46.01	---	---	65.29	55.29	-9.28
	1233.000	43.81	---	---	63.63	53.63	-9.82
	3271.000	42.70	---	---	62.54	52.54	-9.84
	3349.000	36.85	---	---	56.00	46.00	-9.15
	3638.000	42.52	---	---	56.00	46.00	-3.48
	4666.000	36.71	---	---	56.00	46.00	-9.29

#### **IV. Section 15.247 (a): Technical description of the EUT**

*Direct Sequence System* is a spread spectrum system in which the carrier has been modulated by a high speed spreading code and an information data stream. The high speed code sequence dominates the “modulating function” and is the direct cause of the wide spreading of the transmitted signal. In the operational description demonstrates the operation principles of the Baseband processor employed by the EUT, shows that which is a complete DSSS baseband processor and meets the definition of the direct sequence spread spectrum system.

## V. Section 15.247(a)(2): Bandwidth for Direct Sequence System.

### 5.1 Test Condition & Setup

The transmitter bandwidth measurements were performed by the contact manner. The EUT was set to transmit continuously, also various channels were investigated to find the maximum occupied bandwidth. The output of the EUT was connected to the spectrum analyzer. The bandwidth of the fundamental frequency is observed by the spectrum analyzer with 100kHz RBW and 100kHz VBW.

### 5.2 Test Instruments Configuration

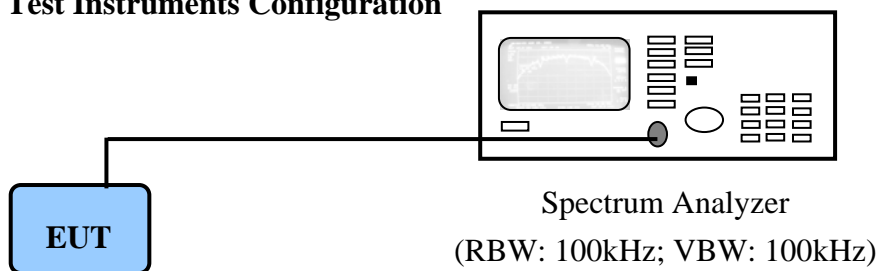

*PC to control the EUT at maximal power output and channel number and set antenna kit*

### 5.3 List of Test Instruments

Instrument Name	Model No.	Brand	Serial No.	Next time
Spectrum Analyzer	MS2665C	ANRITSU	6200175476	03/15/12

**5.4 Test Result of Bandwidth**

**IEEE 802.11b**

Channel	Limited (kHz)	Antenna(MHz)
CH01	$\geq 500$	10.20
CH06	$\geq 500$	10.24
CH11	$\geq 500$	10.20

**IEEE 802.11g**

CH01	$\geq 500$	16.76
CH06	$\geq 500$	16.72
CH11	$\geq 500$	16.72

**IEEE 802.11n 20M**

CH01	$\geq 500$	17.96
CH06	$\geq 500$	17.92
CH11	$\geq 500$	17.92

- Note:
1. The data in the above table are summarizing the following attachment spectrum analyzer hard copy. According to the guidance, we'd made the measurement with the spectrum analyzer's resolution bandwidth ( $RBW$ )= $100kHz$  and set the  $span \gg RBW$ . The results show the measured 6dB bandwidth comply with the minimum 500kHz requirement.
  2. The attachments show these on the following pages.

**6dB Bandwidth of Channel CH01 IEEE 802.11b, 2412MHz**

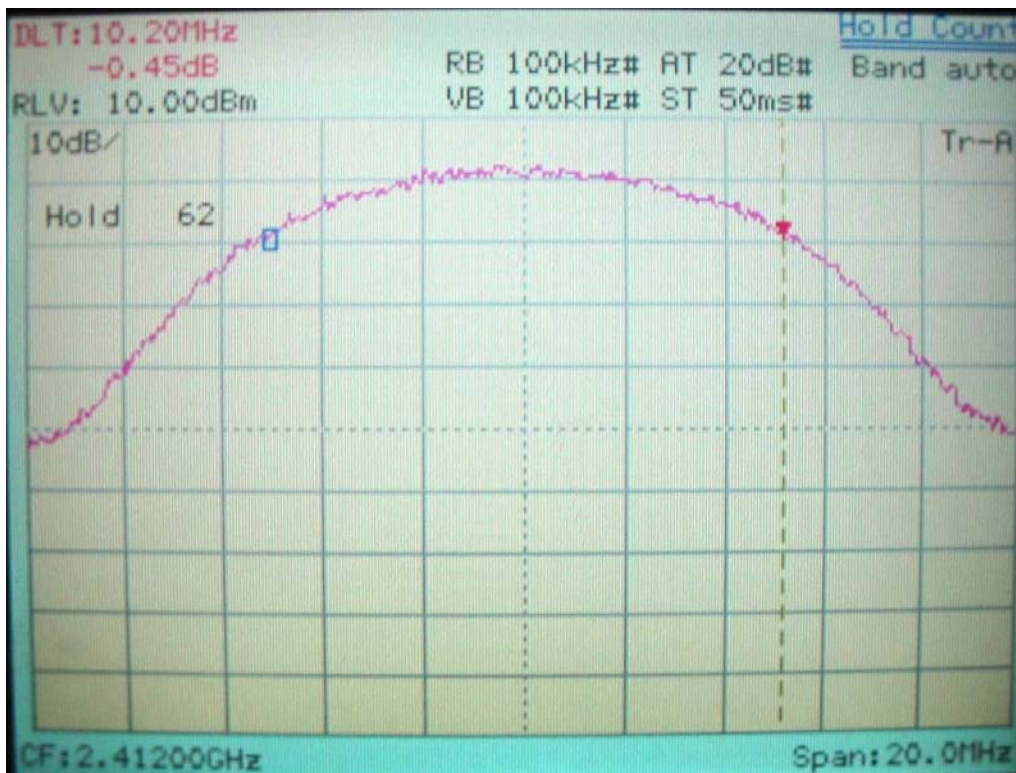

**6dB Bandwidth of Channel CH06 IEEE 802.11b, 2437MHz**

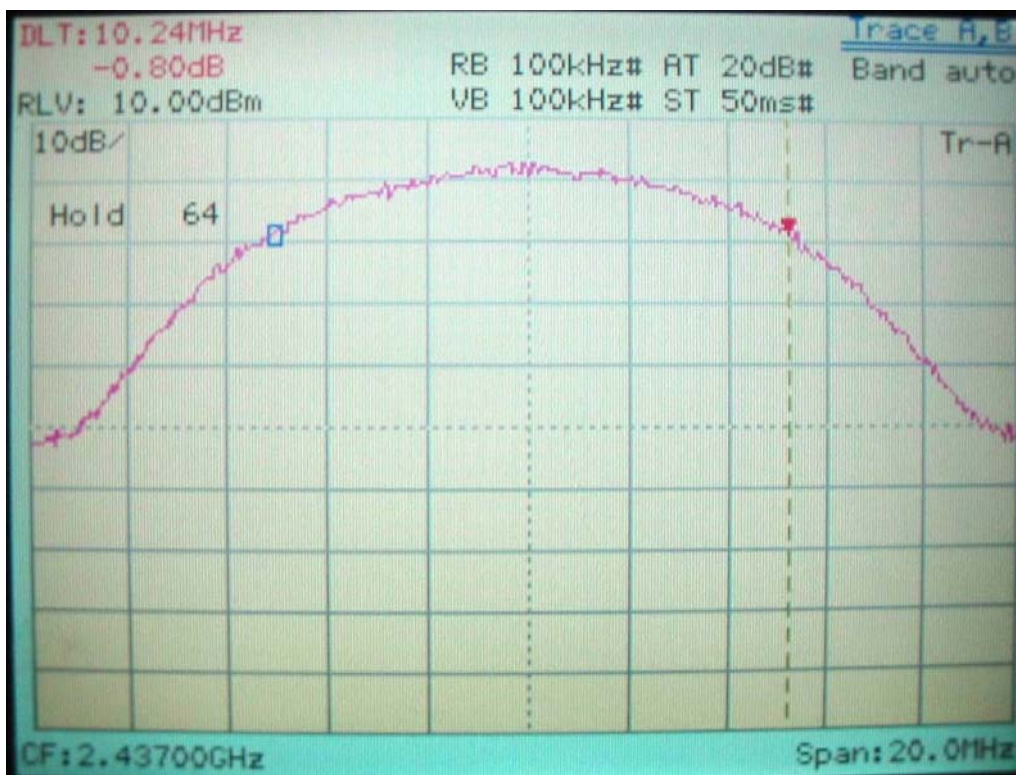

**6dB Bandwidth of Channel CH11 IEEE 802.11b, 2462MHz**

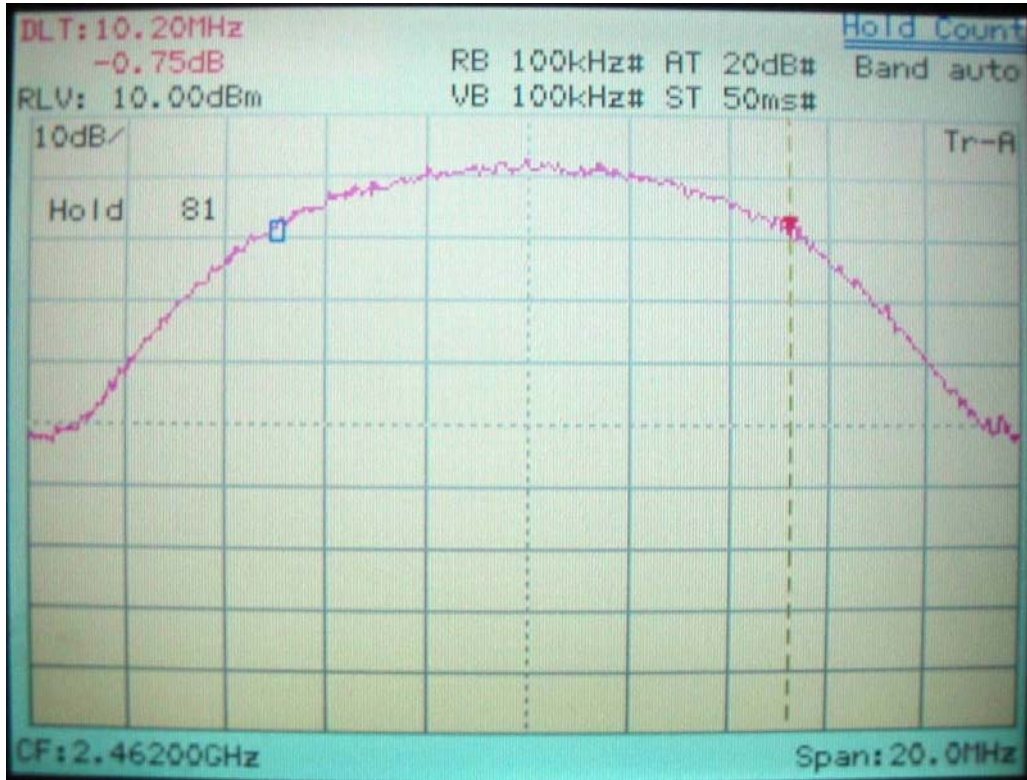

**6dB Bandwidth of Channel CH01 IEEE 802.11g, 2412MHz**

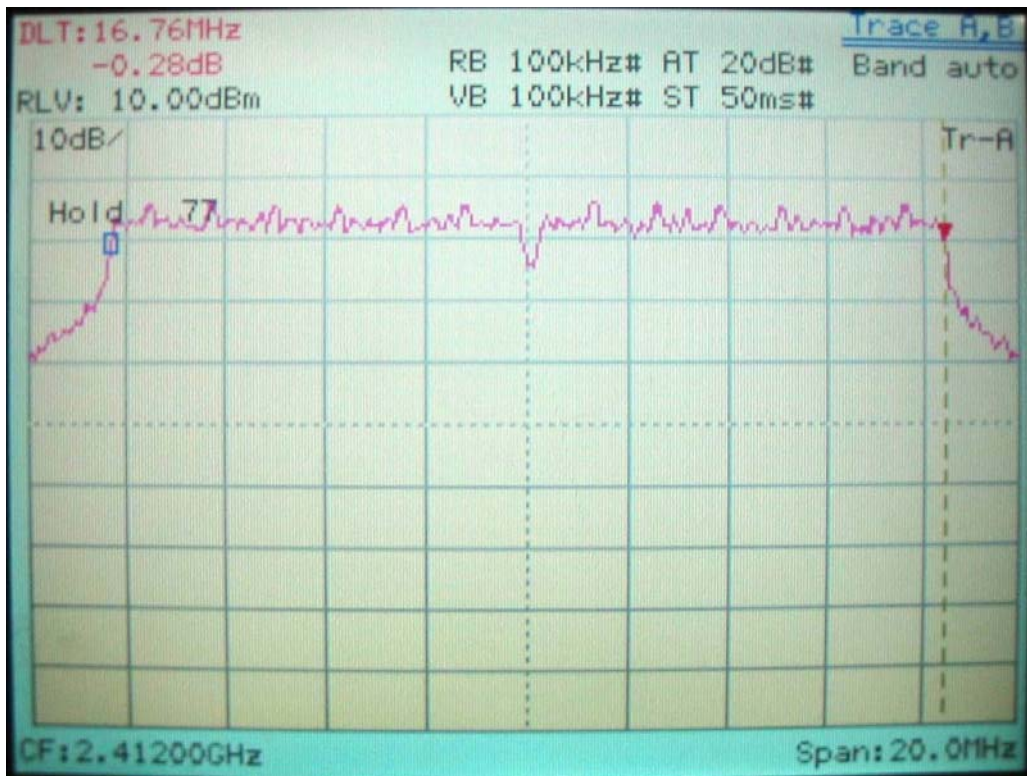

**6dB Bandwidth of Channel CH06 IEEE 802.11g, 2437MHz**



**6dB Bandwidth of Channel CH11 IEEE 802.11g, 2462MHz**

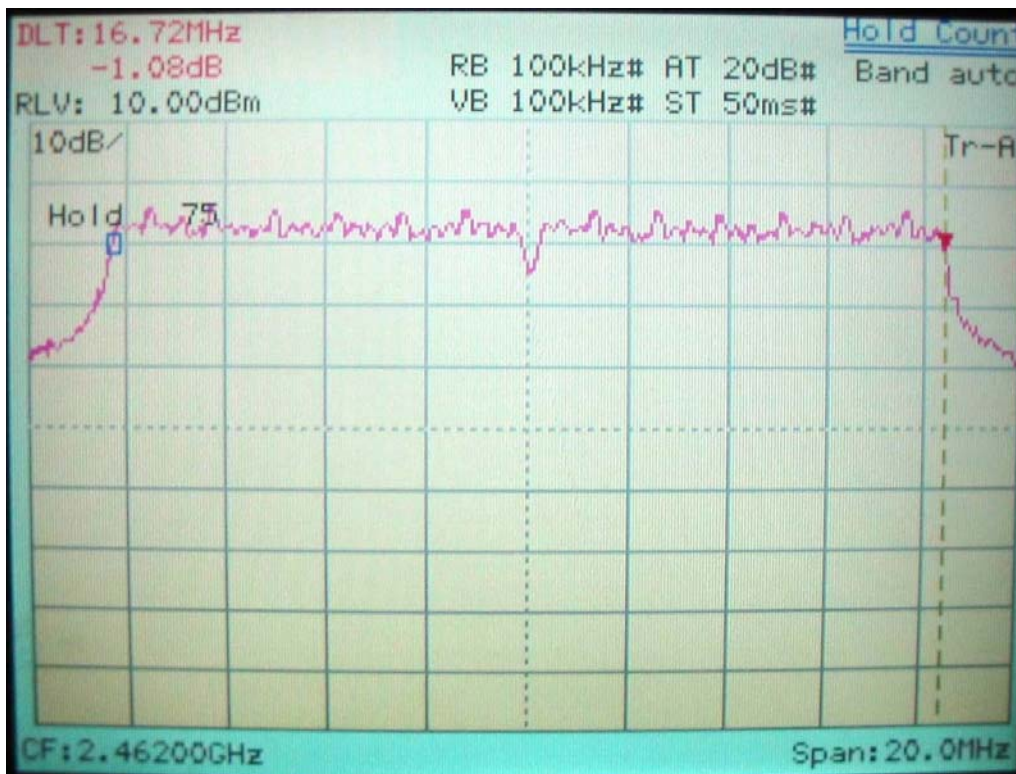

**6dB Bandwidth of Channel 01 IEEE 802.11n 20M, 2412MHz**



**6dB Bandwidth of Channel 06 IEEE 802.11n 20M, 2437MHz**

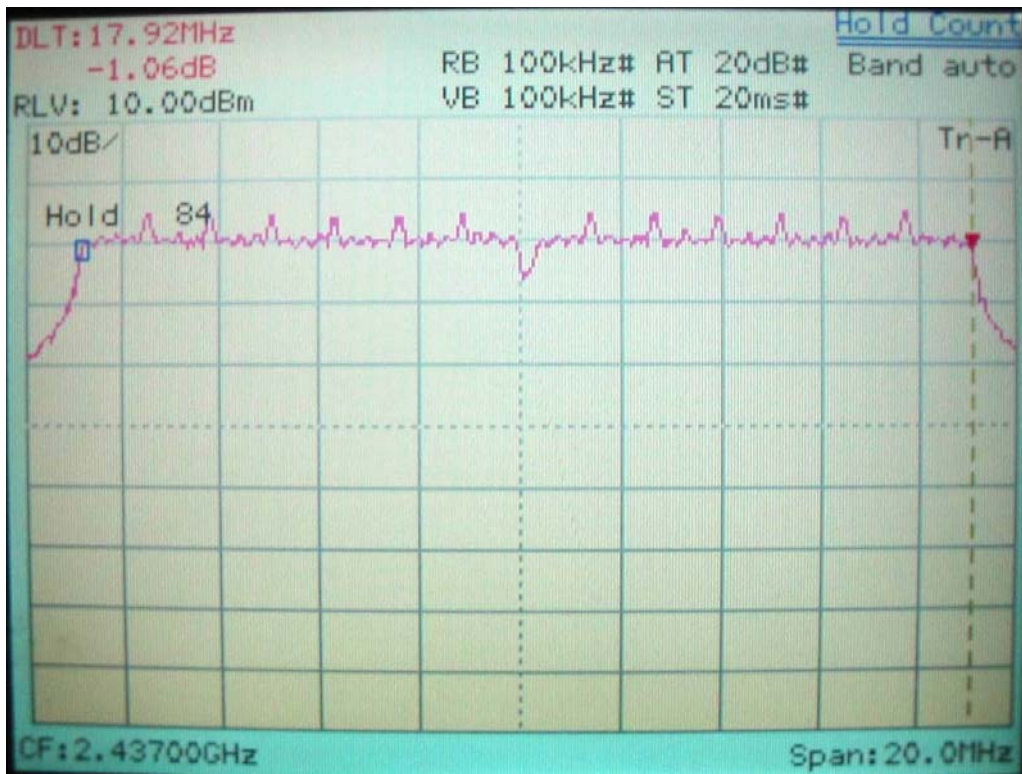



**6dB Bandwidth of Channel 11 IEEE 802.11n 20M, 2462MHz**

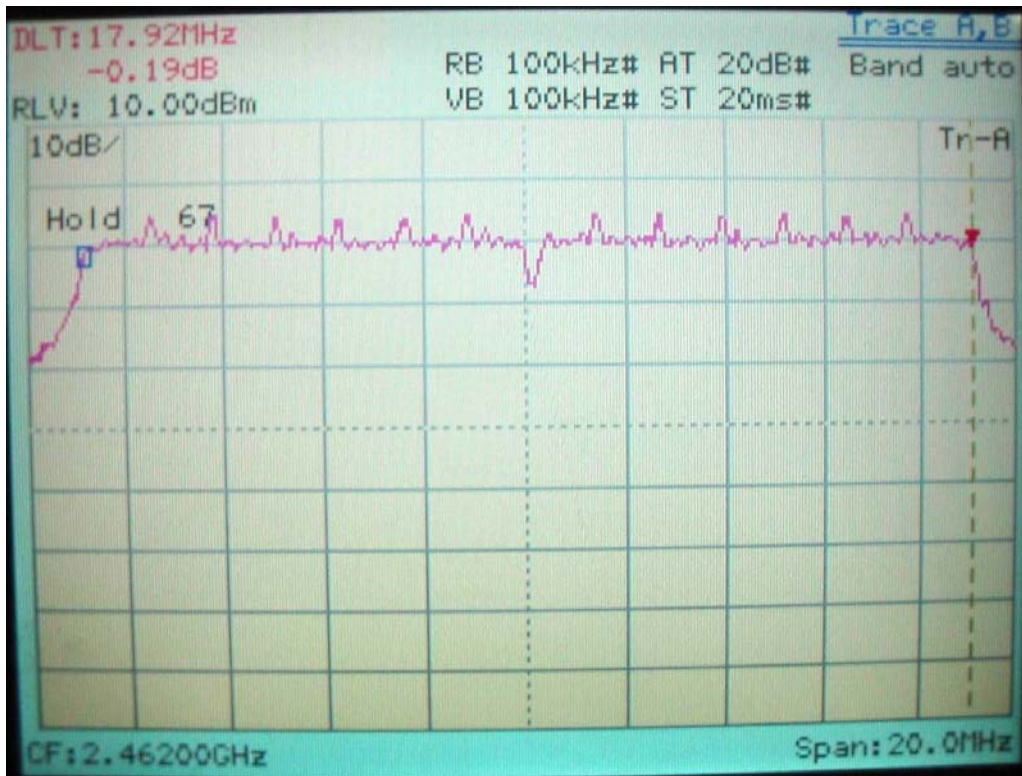

## VI. Section 15.247(b): Power Output

### 6.1 Test Condition & Setup

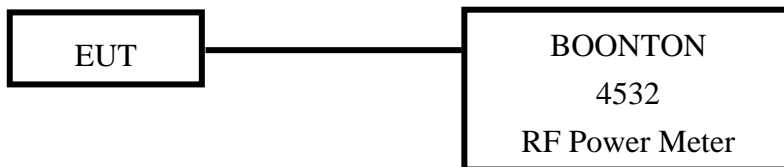

1. The output of the transmitter is connected to the BOONTON RF Power Meter.
2. The calibration is performed before every test. The values of the output power of the EUT will shown in the dBm directly are the transmitter output peak power. Recording as follows.

### 6.2 List of Test Instruments

Instrument Name	Model	Brand	Serial No.	Next time
RF Power Meter	4532	BOONTON	117501	03/06/12
Peak Power Sensor	57340	BOONTON	2696	04/26/12

### 6.3 Test Result

**Formula:**  
 RF Output of EUT + |Cable Loss| = Output Peak Power

Channel (MHz)	Output Level	Cable Loss	Limit	Output Peak Power	
	dBm	dBm	(DSS)	dBm	mW

#### IEEE 802.11b

<b>CH 01 /2412</b>	14.876	7.00	30dBm	21.876	154.03
<b>CH 06 /2437</b>	14.924	7.00	30dBm	21.924	155.74
<b>CH 11 /2462</b>	14.849	7.00	30dBm	21.849	153.07

#### IEEE 802.11g

<b>CH 01 /2412</b>	16.530	7.00	30dBm	23.530	225.42
<b>CH 06 /2437</b>	16.414	7.00	30dBm	23.414	219.48
<b>CH 11 /2462</b>	16.293	7.00	30dBm	23.293	213.45

Channel (MHz)	Output Level	Cable Loss	Limit	Output Peak Power	
	<b>dBm</b>		<b>dBm</b>	(DSS)	<b>dBm</b>
<b>802.11n 20M</b>					
<b>CH 01 /2412</b>	16.032	7.00	30dBm	23.032	201.00
<b>CH 06 /2437</b>	15.781	7.00	30dBm	22.781	189.71
<b>CH 11 /2462</b>	15.906	7.00	30dBm	22.906	195.25

## VII. Section 15.247 (C): Spurious Emissions (Radiated)

### 7.1 Test Condition & Setup

We'd performed the test by the *radiated emission* skill: The EUT was placed in an semi-anechoic chamber, and set the EUT transmitting continuously and scanned at 3-meter distance to determine its emission characteristics. The physical arrangement of the EUT was varied (within the scope of arrangements likely to be encountered in actual use) to determine the effect on the unit's emanations in amplitude, directivity, and frequency. The exact system configuration, which produced the highest emissions was noted so it could be reproduced later during the final tests. For the measurement above 1GHz, according to the guidance we'd set the spectrum analyzer's 6dB bandwidth RBW to 1MHz.

This was done to ensure that the final measurements would demonstrate the worst-case interference potential of the EUT.

Final radiation measurements were made on a three-meter, semi-anechoic chamber. The EUT system was placed on a nonconductive turntable, which is 0.8 meters height, top surface 1.0 x 1.5 meter.

The spectrum was examined from 30MHz to 1000MHz using an Hewlett Packard 85460A EMI Receiver, SCHWARZECK whole range Small Biconical Antenna (Model No.: UBAA9114 & BBVU9135) is used to measure frequency from 30 MHz to 1GHz. The final test is used the HP 85460A spectrum and 8564E spectrum was examined from 1GHz to 25GHz using an Hewlett Packard Spectrum Analyzer, EMCO/HP Horn Antenna (Model 3115 / 84125-80008) for 1G - 25GHz.

At each frequency, the EUT was rotated 360 degrees, and the antenna was raised and lowered from one to four meters to find the maximum emission levels. Measurements were taken using both horizontal and vertical antenna polarization.

Appropriate preamplifiers were used for improving sensitivity and precautions were taken to avoid overloading or desensitizing the spectrum analyzer. There are two spectrum analyzers use on this testing, HP 85460A for frequency 30MHz to 1000MHz, and 8564E for frequency 1GHz to 25GHz. No post-detector video filters were used in the test. The spectrum analyzer's 6dB bandwidth was set to 120KHz (spectrum was examined from 30 MHz to 1000 MHz), the spectrum analyzer's 6 dB bandwidth was set to 1 MHz (spectrum was examined from 1GHz to 25GHz) and the analyzer was operated in the maximum hold mode. There is a test condition applies in this test item, the test procedure description as the following:

Three channels were tested, one in the top, one in the middle and the other in bottom. The setting up procedure is recorded on <1.3>

With the transmitter operating from a AC source and using the internal of EUT, radiates spurious emissions falling within the restricted bands of 15.209 were measured at operating frequencies corresponding to upper, middle and bottom channels in the 2400 ~ 2483.5 MHz band.

The actual field intensity in decibels referenced to 1 microvolt per meter (dB $\mu$ V/m) is determined by algebraically adding the measured reading in dB $\mu$ V, the antenna factor (dB), and cable loss (dB) at the appropriate frequency. Since the EUT was set to transmit continuously, no *duty cycle* is present.

**For frequency between 30MHz to 1000MHz**

$$F_{Ia} \text{ (dB}\mu\text{V/m)} = F_{Ir} \text{ (dB}\mu\text{V)} + \text{Correction Factors}$$

F<sub>Ia</sub> : Actual Field Intensity

F<sub>Ir</sub> : Reading of the Field Intensity

Correction Factors = Antenna Factor + (Cable Loss – Amplifier Gain) + Switching Box Loss

**For frequency between 1GHz to 25GHz**

$$F_{Ia} \text{ (dB}\mu\text{V/m)} = F_{Ir} \text{ (dB}\mu\text{V)} + \text{Correction Factor}$$

F<sub>Ia</sub> : Actual Field Intensity

F<sub>Ir</sub> : Reading of the Field Intensity

Correction Factors = Antenna Factor + (Cable Loss – Amplifier Gain) + Switching Box Loss

**7.2 List of Test Instruments**

				<u>Calibration Date</u>
<b>Instrument Name</b>	<b>Model</b>	<b>Brand</b>	<b>Serial No.</b>	<b>Next time</b>
EMI Receiver	8546A	HP	3520A00242	03/12/12
RF Filter Section	85460A	HP	3448A00217	03/12/12
Small Biconical Antenna	UBAA9114 & BBVU9135	Schwarzeck	127	03/21/12
Pre-amplifier	PA1F	TRC	1FAC	04/06/12
Coaxial Cable (Double shielded, 15 meter)	A30A30-0058-50FS-15M	Jyebao	SMA-01	04/06/12
Coaxial Cable (1.1 meter)	A30A30-0058-50FS-1M	JYEBAO	SMA-02	04/06/12
Spectrum Analyzer	8564E	HP	3720A00840	04/13/12
Microwave Preamplifier	84125C	HP	US36433002	04/19/12
Horn Antenna	3115	EMCO	9104-3668	02/11/12
Standard Guide Horn Antenna	84125-80008	HP	18-26.5GHz	01/26/12
Standard Guide Horn Antenna	84125-80001	HP	26.5-40GHz	01/27/12
Horn Antenna	1196E (3115)	HP (EMCO)	9704-5178	01/31/12
Pre-amplifier	PA2F	TRC	2F1GZ	04/09/12
Coaxial Cable (3 miter)	A30A30-0058-50FST118	JYEBAO	MSA-05	04/09/12
Coaxial Cable (1 meter)	A30A30-0058-50FST118	JYEBAO	MSA-04	04/09/12

**7.3 Test Result of Spurious Radiated Emissions**

The highest peak values of radiated emissions from the EUT at various antenna heights, antenna polarizations, EUT orientation, etc. are recorded on the following.

Test Conditions: Temperature : 25 ° C Humidity : 73 % RH

*Test mode: IEEE 802.11b CH01 for 30MHz to 1GHz [Horizontal]*

Radiated Emission				Correction Factors (dB)	Corrected Amplitude (dBµV/m)	Class B ( 3 m )	
Frequency (MHz)	Amplitude (dBµV)	Ant. H. (m)	Table ( )			Limit (dBµV/m)	Margin (dB)
101.54	36.39	1.00	319	-1.04	35.35	43.50	-8.15
196.60	43.51	1.00	146	-2.92	40.59	43.50	-2.91
262.80	39.74	1.00	119	-3.45	36.29	46.00	-9.71
299.08	43.15	1.00	180	-2.82	40.33	46.00	-5.67
367.07	38.04	1.00	170	-1.83	36.21	46.00	-9.79
951.50	23.25	1.00	234	15.42	38.67	46.00	-7.33

*Test mode: IEEE 802.11b CH01 for 30MHz to 1GHz [Vertical]*

Radiated Emission				Correction Factors (dB)	Corrected Amplitude (dBµV/m)	Class B ( 3 m )	
Frequency (MHz)	Amplitude (dBµV)	Ant. H. (m)	Table ( )			Limit (dBµV/m)	Margin (dB)
100.32	35.99	1.00	128	-0.98	35.01	43.50	-8.49
130.64	31.41	1.00	160	-2.69	28.72	43.50	-14.78
199.75	36.62	1.00	25	-2.81	33.81	43.50	-9.69
300.39	39.38	1.00	132	-2.83	36.55	46.00	-9.45
696.87	30.94	1.00	280	9.30	40.24	46.00	-5.76
946.65	24.58	1.00	76	15.30	39.88	46.00	-6.12

Note:

1. Margin = Amplitude – limit, if margin is minus means under limit.
2. Corrected Amplitude = Reading Amplitude + Correction Factors
3. Correction factor = Antenna factor + (Cable Loss – Amplitude gain) + Switching Box Loss

Test mode: IEEE 802.11b CH01 for 1GHz to 26.5GHz [Horizontal]

Frequency	Ant. H.	Table	Amplitude		Correction Factor	Corrected Amplitude		Limit		Margin
			Peak / Ave.			Peak / Ave.		Peak / Ave.		
MHz	m	degree	dBµV		dB/m	dBµV/m		dBµV/m		dB
2251.46	1.00	354	48.71	35.66	8.79	57.50	44.45	73.96	53.96	-9.51
2292.20	1.00	46	49.11	34.72	8.91	58.02	43.63	73.96	53.96	-10.33
2331.46	1.00	169	56.63	41.50	9.02	65.65	50.52	73.96	53.96	-3.44
2491.48	1.00	110	55.51	40.35	9.47	64.98	49.82	73.96	53.96	-4.14
2532.45	1.00	38	48.24	33.63	9.55	57.79	43.18	73.96	53.96	-10.78
2572.02	1.00	103	52.56	38.49	9.63	62.19	48.12	73.96	53.96	-5.84
4821.00	1.00	265	65.77	57.78	-9.16	56.61	48.62	73.96	53.96	-5.34
7236.58	1.00	92	64.30	58.01	-9.42	54.88	48.59	73.96	53.96	-5.37
9648.02	1.00	76	69.44	58.91	-6.72	62.72	52.19	73.96	53.96	-1.77
12061.47	1.00	120	76.62	62.61	-10.65	65.97	51.96	73.96	53.96	-2.00

Note:

1. Margin = Corrected - Limit.
2. The EUT utilizes a *permanently attached antenna*. In addition the spurious RF radiated emissions levels do comply with the *20dBc limit* both at its bandedges and other spurious emissions.
3. As stated in Section 15.35(b), for any frequencies above 1000MHz, radiated limits shown are based upon the use of measurement instrumentation employing an average detector function. As the results of our test, the peak amplitudes are already below the FCC limit. Thus the average amplitudes of the rest are omitted.



Test mode: IEEE 802.11b CH01 for 1GHz to 26.5GHz [Vertical]

Frequency	Ant. H.	Table	Amplitude Peak / Ave.		Correction Factor	Corrected Amplitude Peak / Ave.		Limit Peak / Ave.		Margin
MHz	m	degree	dB $\mu$ V		dB/m	dB $\mu$ V/m		dB $\mu$ V/m		dB
2332.04	1.00	148	46.42	34.92	9.02	55.44	43.94	73.96	53.96	-10.02
2491.49	1.00	146	45.95	35.01	9.47	55.42	44.48	73.96	53.96	-9.48
4824.00	1.00	116	71.48	60.95	-9.16	62.32	51.79	73.96	53.96	-2.17
7234.70	1.00	60	63.97	58.12	-9.41	54.56	48.71	73.96	53.96	-5.25
9648.01	1.00	98	67.06	59.29	-6.72	60.34	52.57	73.96	53.96	-1.39
12059.44	1.00	80	72.61	62.18	-10.65	61.96	51.53	73.96	53.96	-2.43

*Test mode: IEEE 802.11b CH06 for 30MHz to 1GHz [Horizontal]*

<b>Radiated Emission</b>				<b>Correction Factors</b>	<b>Corrected Amplitude</b>	<b>Class B (3 m)</b>	
<b>Frequency (MHz)</b>	<b>Amplitude (dBμV)</b>	<b>Ant. H. (m)</b>	<b>Table ( )</b>			<b>Limit (dBμV/m)</b>	<b>Margin (dB)</b>
100.32	35.55	1.00	307	-0.98	34.57	43.50	-8.93
196.60	43.98	1.00	127	-2.92	41.06	43.50	-2.44
259.16	40.57	1.00	173	-3.48	37.09	46.00	-8.91
298.86	44.94	1.00	162	-2.81	42.13	46.00	-3.87
367.07	38.18	1.00	162	-1.83	36.35	46.00	-9.65
696.87	25.53	1.00	273	9.30	34.83	46.00	-11.17

*Test mode: IEEE 802.11b CH06 for 30MHz to 1GHz [Vertical]*

<b>Radiated Emission</b>				<b>Correction Factors</b>	<b>Corrected Amplitude</b>	<b>Class B (3 m)</b>	
<b>Frequency (MHz)</b>	<b>Amplitude (dBμV)</b>	<b>Ant. H. (m)</b>	<b>Table ( )</b>			<b>Limit (dBμV/m)</b>	<b>Margin (dB)</b>
100.32	36.77	1.00	135	-0.98	35.79	43.50	-7.71
130.64	31.55	1.00	145	-2.69	28.86	43.50	-14.64
197.32	35.88	1.00	13	-2.89	32.99	43.50	-10.51
300.39	38.68	1.00	148	-2.83	35.85	46.00	-10.15
501.66	29.24	1.00	121	3.03	32.27	46.00	-13.73
696.87	31.31	1.00	273	9.30	40.61	46.00	-5.39

Test mode: IEEE 802.11b CH06 for 1GHz to 26.5GHz [Horizontal]

Frequency	Ant. H.	Table	Amplitude		Correction Factor	Corrected Amplitude		Limit		Margin
			Peak / Ave.			Peak / Ave.		Peak / Ave.		
MHz	m	degree	dBμV		dB/m	dBμV/m		dBμV/m		dB
2276.45	1.00	331	48.41	33.98	8.86	57.27	42.84	73.96	53.96	-11.12
2356.46	1.00	143	58.90	42.19	9.09	67.99	51.28	73.96	53.96	-2.68
2518.45	1.00	139	58.41	41.52	9.52	67.93	51.04	73.96	53.96	-2.92
2600.46	1.00	88	50.56	37.38	9.68	60.24	47.06	73.96	53.96	-6.90
4870.99	1.00	166	71.12	58.74	-9.20	61.92	49.54	73.96	53.96	-4.42
7312.57	1.00	344	66.90	58.64	-9.50	57.40	49.14	73.96	53.96	-4.82
9748.03	1.00	108	71.17	59.69	-7.13	64.04	52.56	73.96	53.96	-1.40
12186.46	1.00	126	77.71	62.32	-11.15	66.56	51.17	73.96	53.96	-2.79

Test mode: IEEE 802.11b CH06 for 1GHz to 26.5GHz [Vertical]

Frequency	Ant. H.	Table	Amplitude		Correction Factor	Corrected Amplitude		Limit		Margin
			Peak / Ave.			Peak / Ave.		Peak / Ave.		
MHz	m	degree	dBμV		dB/m	dBμV/m		dBμV/m		dB
2356.48	1.00	74	52.27	36.64	9.09	61.36	45.73	73.96	53.96	-8.23
2520.48	1.00	172	46.15	35.22	9.53	55.68	44.75	73.96	53.96	-9.21
4871.01	1.00	168	71.14	60.59	-9.20	61.94	51.39	73.96	53.96	-2.57
7310.59	1.00	66	69.61	58.94	-9.50	60.11	49.44	73.96	53.96	-4.52
9748.02	1.00	108	71.71	59.63	-7.13	64.58	52.50	73.96	53.96	-1.46
12181.82	1.00	117	76.16	59.83	-11.13	65.03	48.70	73.96	53.96	-5.26

*Test mode: IEEE 802.11b CH11 for 30MHz to 1GHz [Horizontal]*

<b>Radiated Emission</b>				<b>Correction Factors</b>	<b>Corrected Amplitude</b>	<b>Class B (3 m)</b>	
<b>Frequency (MHz)</b>	<b>Amplitude (dBμV)</b>	<b>Ant. H. (m)</b>	<b>Table ( )</b>			<b>Limit (dBμV/m)</b>	<b>Margin (dB)</b>
100.32	35.99	1.00	313	-0.98	35.01	43.50	-8.49
196.60	44.24	1.00	153	-2.92	41.32	43.50	-2.18
257.95	41.29	1.00	103	-3.46	37.83	46.00	-8.17
299.50	43.59	1.00	173	-2.82	40.77	46.00	-5.23
368.29	38.13	1.00	177	-1.80	36.33	46.00	-9.67
696.87	24.93	1.00	273	9.30	34.23	46.00	-11.77

*Test mode: IEEE 802.11b CH11 for 30MHz to 1GHz [Vertical]*

<b>Radiated Emission</b>				<b>Correction Factors</b>	<b>Corrected Amplitude</b>	<b>Class B (3 m)</b>	
<b>Frequency (MHz)</b>	<b>Amplitude (dBμV)</b>	<b>Ant. H. (m)</b>	<b>Table ( )</b>			<b>Limit (dBμV/m)</b>	<b>Margin (dB)</b>
102.75	31.21	1.00	121	-1.10	36.47	43.50	-7.03
130.64	31.21	1.00	151	-2.69	28.52	43.50	-14.98
198.54	34.98	1.00	40	-2.85	32.13	43.50	-11.37
300.39	38.54	1.00	145	-2.83	35.71	46.00	-10.29
500.45	28.16	1.00	124	2.97	31.13	46.00	-14.87
696.87	31.01	1.00	266	9.30	40.31	46.00	-5.69

Test mode: IEEE 802.11b CH11 for 1GHz to 26.5GHz [Horizontal]

Frequency	Ant. H.	Table	Amplitude		Correction Factor	Corrected Amplitude		Limit		Margin
			Peak / Ave.			Peak / Ave.		Peak / Ave.		
MHz	m	degree	dB $\mu$ V		dB/m	dB $\mu$ V/m		dB $\mu$ V/m		dB
2303.02	1.00	139	52.71	37.20	8.94	61.65	46.14	73.96	53.96	-7.82
2343.47	1.00	109	48.70	35.72	9.05	57.75	44.77	73.96	53.96	-9.19
2382.35	1.00	94	53.93	40.16	9.16	63.09	49.32	73.96	53.96	-4.64
2541.93	1.00	127	56.64	40.99	9.57	66.21	50.56	73.96	53.96	-3.40
2622.26	1.00	154	52.08	37.79	9.72	61.80	47.51	73.96	53.96	-6.45
4923.99	1.00	158	71.09	59.77	-9.25	61.84	50.52	73.96	53.96	-3.44
7386.58	1.00	115	71.89	59.06	-9.58	62.31	49.48	73.96	53.96	-4.48
9848.02	1.00	107	72.24	59.61	-7.55	64.69	52.07	73.96	53.96	-1.89
12304.35	1.00	124	77.98	59.68	-11.62	66.36	48.06	73.96	53.96	-5.90

Test mode: IEEE 802.11b CH11 for 1GHz to 26.5GHz [Vertical]

Frequency	Ant. H.	Table	Amplitude		Correction Factor	Corrected Amplitude		Limit		Margin
			Peak / Ave.			Peak / Ave.		Peak / Ave.		
MHz	m	degree	dB $\mu$ V		dB/m	dB $\mu$ V/m		dB $\mu$ V/m		dB
2381.44	1.00	25	45.05	34.92	9.16	54.21	44.08	73.96	53.96	-9.88
2541.46	1.00	344	47.83	35.02	9.57	57.40	44.59	73.96	53.96	-9.37
2621.96	1.00	59	43.65	33.30	9.72	53.37	43.02	73.96	53.96	-10.94
4924.00	1.00	122	70.73	61.62	-9.25	61.48	52.37	73.96	53.96	-1.59
7385.59	1.00	152	71.36	59.17	-9.58	61.78	49.59	73.96	53.96	-4.37
9848.01	1.00	103	71.63	59.66	-7.55	64.08	52.11	73.96	53.96	-1.85
12304.82	1.00	79	73.21	57.82	-11.62	61.59	46.20	73.96	53.96	-7.76

*Test mode: IEEE 802.11g CH01 for 30MHz to 1GHz [Horizontal]*

<b>Radiated Emission</b>				<b>Correction Factors</b> <i>(dB)</i>	<b>Corrected Amplitude</b> <i>(dBμV/m)</i>	<b>Class B (3 m)</b>	
<b>Frequency (MHz)</b>	<b>Amplitude (dBμV)</b>	<b>Ant. H. (m)</b>	<b>Table ( )</b>			<b>Limit (dBμV/m)</b>	<b>Margin (dB)</b>
100.32	36.31	1.00	319	-0.98	35.33	43.50	-8.17
196.60	44.03	1.00	156	-2.92	41.11	43.50	-2.39
262.80	42.14	1.00	200	-3.45	38.69	46.00	-7.31
298.99	43.02	1.00	170	-2.81	40.21	46.00	-5.79
368.29	37.76	1.00	323	-1.80	35.96	46.00	-10.04
946.65	22.76	1.00	220	15.30	38.06	46.00	-7.94

*Test mode: IEEE 802.11g CH01 for 30MHz to 1GHz [Vertical]*

<b>Radiated Emission</b>				<b>Correction Factors</b> <i>(dB)</i>	<b>Corrected Amplitude</b> <i>(dBμV/m)</i>	<b>Class B (3 m)</b>	
<b>Frequency (MHz)</b>	<b>Amplitude (dBμV)</b>	<b>Ant. H. (m)</b>	<b>Table ( )</b>			<b>Limit (dBμV/m)</b>	<b>Margin (dB)</b>
101.54	35.77	1.00	131	-1.04	34.73	43.50	-8.77
198.54	35.62	1.00	7	-2.85	32.77	43.50	-10.73
301.60	38.28	1.00	145	-2.81	35.47	46.00	-10.53
502.87	28.43	1.00	128	3.08	31.51	46.00	-14.49
696.87	31.49	1.00	301	9.30	40.79	46.00	-5.21
895.72	22.21	1.00	252	14.64	36.85	46.00	-9.15

*Test mode: IEEE 802.11g CH01 for 1GHz to 26.5GHz [Horizontal]*

Frequency	Ant. H.	Table	Amplitude		Correction Factor	Corrected Amplitude		Limit		Margin
			Peak / Ave.			Peak / Ave.		Peak / Ave.		
MHz	m	degree	dBµV		dB/m	dBµV/m		dBµV/m		dB
2256.39	1.00	103	50.15	27.00	8.81	58.96	35.81	73.96	53.96	-15.00
2335.11	1.00	125	54.83	29.17	9.03	63.86	38.20	73.96	53.96	-10.10
2492.30	1.00	102	58.16	29.50	9.47	67.63	38.97	73.96	53.96	-6.33
2568.26	1.00	125	52.17	28.17	9.62	61.79	37.79	73.96	53.96	-12.17
4822.99	1.00	153	63.78	54.53	-9.16	54.62	45.37	73.96	53.96	-8.59
7239.44	1.00	119	61.91	51.51	-9.42	52.49	42.09	73.96	53.96	-11.87
9647.42	1.00	148	62.15	51.45	-6.71	55.44	44.74	73.96	53.96	-9.22
12053.74	1.00	108	68.88	54.51	-10.62	58.26	43.89	73.96	53.96	-10.07

*Test mode: IEEE 802.11g CH01 for 1GHz to 26.5GHz [Vertical]*

Frequency	Ant. H.	Table	Amplitude		Correction Factor	Corrected Amplitude		Limit		Margin
			Peak / Ave.			Peak / Ave.		Peak / Ave.		
MHz	m	degree	dBµV		dB/m	dBµV/m		dBµV/m		dB
2259.70	1.00	253	43.66	25.50	8.82	52.48	34.32	73.96	53.96	-19.64
2324.52	1.00	148	49.67	27.50	9.00	58.67	36.50	73.96	53.96	-15.29
2491.08	1.00	147	51.01	28.00	9.47	60.48	37.47	73.96	53.96	-13.48
2578.21	1.00	147	43.49	25.83	9.64	53.13	35.47	73.96	53.96	-18.49
4817.12	1.00	72	67.44	54.84	-9.16	58.28	45.68	73.96	53.96	-8.28
7233.52	1.00	105	59.62	51.55	-9.41	50.21	42.14	73.96	53.96	-11.82
9642.02	1.00	242	63.07	51.32	-6.69	56.38	44.63	73.96	53.96	-9.33
12063.12	1.00	350	68.12	54.15	-10.66	57.46	43.49	73.96	53.96	-10.47

*Test mode: IEEE 802.11g CH06 for 30MHz to 1GHz [Horizontal]*

<b>Radiated Emission</b>				<b>Correction Factors</b>	<b>Corrected Amplitude</b>	<b>Class B (3 m)</b>	
<b>Frequency (MHz)</b>	<b>Amplitude (dBμV)</b>	<b>Ant. H. (m)</b>	<b>Table ( )</b>			<b>Limit (dBμV/m)</b>	<b>Margin (dB)</b>
100.32	36.22	1.00	329	-0.98	35.24	43.50	-8.26
196.60	43.65	1.00	156	-2.92	40.73	43.50	-2.77
260.37	40.62	1.00	200	-3.48	37.14	46.00	-8.86
299.50	43.27	1.00	180	-2.82	40.45	46.00	-5.55
365.86	38.06	1.00	170	-1.87	36.19	46.00	-9.81
950.29	22.79	1.00	76	15.35	38.14	46.00	-7.86

*Test mode: IEEE 802.11g CH06 for 30MHz to 1GHz [Vertical]*

<b>Radiated Emission</b>				<b>Correction Factors</b>	<b>Corrected Amplitude</b>	<b>Class B (3 m)</b>	
<b>Frequency (MHz)</b>	<b>Amplitude (dBμV)</b>	<b>Ant. H. (m)</b>	<b>Table ( )</b>			<b>Limit (dBμV/m)</b>	<b>Margin (dB)</b>
100.32	36.10	1.00	136	-0.98	35.12	43.50	-8.38
130.64	30.35	1.00	136	-2.69	27.66	43.50	-15.84
198.54	35.12	1.00	24	-2.85	32.27	43.50	-11.23
302.81	38.34	1.00	149	-2.80	35.54	46.00	-10.46
500.45	28.76	1.00	122	2.97	31.73	46.00	-14.27
696.87	31.18	1.00	283	9.30	40.48	46.00	-5.52



*Test mode: IEEE 802.11g CH06 for 1GHz to 26.5GHz [Horizontal]*

<i>Frequency</i>	<i>Ant. H.</i>	<i>Table</i>	<i>Amplitude</i>		<i>Correction Factor</i>	<i>Corrected Amplitude</i>		<i>Limit</i>		<i>Margin</i>
			<i>Peak / Ave.</i>			<i>Peak / Ave.</i>		<i>Peak / Ave.</i>		
<i>MHz</i>	<i>m</i>	<i>degree</i>	<i>dBµV</i>		<i>dB/m</i>	<i>dBµV/m</i>		<i>dBµV/m</i>		<i>dB</i>
2269.28	1.00	84	50.17	27.00	8.84	59.01	35.84	73.96	53.96	-14.95
2358.08	1.00	96	59.84	29.67	9.09	68.93	38.76	73.96	53.96	-5.03
2526.84	1.00	109	57.99	29.67	9.54	67.53	39.21	73.96	53.96	-6.43
2605.63	1.00	109	52.17	27.67	9.69	61.86	37.36	73.96	53.96	-12.10
4874.95	1.00	9	63.08	54.24	-9.21	53.87	45.03	73.96	53.96	-8.93
7309.28	1.00	121	61.35	51.38	-9.49	51.86	41.89	73.96	53.96	-12.07
9748.30	1.00	104	63.23	51.07	-7.13	56.10	43.94	73.96	53.96	-10.02
12185.04	1.00	106	70.23	54.70	-11.15	59.08	43.55	73.96	53.96	-10.41

*Test mode: IEEE 802.11g CH06 for 1GHz to 26.5GHz [Vertical]*

<i>Frequency</i>	<i>Ant. H.</i>	<i>Table</i>	<i>Amplitude</i>		<i>Correction Factor</i>	<i>Corrected Amplitude</i>		<i>Limit</i>		<i>Margin</i>
			<i>Peak / Ave.</i>			<i>Peak / Ave.</i>		<i>Peak / Ave.</i>		
<i>MHz</i>	<i>m</i>	<i>degree</i>	<i>dBµV</i>		<i>dB/m</i>	<i>dBµV/m</i>		<i>dBµV/m</i>		<i>dB</i>
2353.05	1.00	159	51.16	27.83	9.08	60.24	36.91	73.96	53.96	-13.72
2511.23	1.00	159	49.00	27.17	9.51	58.51	36.68	73.96	53.96	-15.45
4875.45	1.00	53	67.30	54.74	-9.21	58.09	45.53	73.96	53.96	-8.43
7311.06	1.00	187	61.59	51.55	-9.50	52.09	42.05	73.96	53.96	-11.91
9748.93	1.00	101	63.45	50.80	-7.14	56.31	43.66	73.96	53.96	-10.30
12187.81	1.00	109	67.76	54.32	-11.16	56.60	43.16	73.96	53.96	-10.80

*Test mode: IEEE 802.11g CH11 for 30MHz to 1GHz [Horizontal]*

<b>Radiated Emission</b>				<b>Correction Factors</b> (dB)	<b>Corrected Amplitude</b> (dBμV/m)	<b>Class B (3 m)</b>	
<b>Frequency (MHz)</b>	<b>Amplitude (dBμV)</b>	<b>Ant. H. (m)</b>	<b>Table ( )</b>			<b>Limit (dBμV/m)</b>	<b>Margin (dB)</b>
101.54	36.94	1.00	319	-1.04	35.90	43.50	-7.60
196.60	43.77	1.00	146	-2.92	40.85	43.50	-2.65
211.87	36.20	1.00	136	-2.81	33.39	43.50	-10.11
261.59	41.95	1.00	109	-3.47	38.48	46.00	-7.52
299.50	43.34	1.00	170	-2.82	40.52	46.00	-5.48
899.36	23.23	1.00	145	14.75	37.98	46.00	-8.02

*Test mode: IEEE 802.11g CH11 for 30MHz to 1GHz [Vertical]*

<b>Radiated Emission</b>				<b>Correction Factors</b> (dB)	<b>Corrected Amplitude</b> (dBμV/m)	<b>Class B (3 m)</b>	
<b>Frequency (MHz)</b>	<b>Amplitude (dBμV)</b>	<b>Ant. H. (m)</b>	<b>Table ( )</b>			<b>Limit (dBμV/m)</b>	<b>Margin (dB)</b>
50.61	27.15	1.00	81	4.22	31.37	40.00	-8.63
101.54	36.41	1.00	135	-1.04	35.37	43.50	-8.13
134.27	32.30	1.00	84	-2.95	29.35	43.50	-14.15
198.54	34.78	1.00	34	-2.85	31.93	43.50	-11.57
301.60	38.04	1.00	148	-2.81	35.23	46.00	-10.77
696.87	30.87	1.00	280	9.30	40.17	46.00	-5.83

*Test mode: IEEE 802.11g CH11 for 1GHz to 26.5GHz [Horizontal]*

<i>Frequency</i>	<i>Ant. H.</i>	<i>Table</i>	<i>Amplitude</i>		<i>Correction Factor</i>	<i>Corrected Amplitude</i>		<i>Limit</i>		<i>Margin</i>
			<i>Peak / Ave.</i>			<i>Peak / Ave.</i>		<i>Peak / Ave.</i>		
<i>MHz</i>	<i>m</i>	<i>degree</i>	<i>dBμV</i>		<i>dB/m</i>	<i>dBμV/m</i>		<i>dBμV/m</i>		<i>dB</i>
2295.75	1.00	81	51.66	27.17	8.92	60.58	36.09	73.96	53.96	-13.38
2389.18	1.00	108	56.48	29.33	9.18	65.66	38.51	73.96	53.96	-8.30
2535.13	1.00	108	59.17	29.50	9.56	68.73	39.06	73.96	53.96	-5.23
2614.85	1.00	108	52.00	28.33	9.71	61.71	38.04	73.96	53.96	-12.25
4924.30	1.00	94	67.75	53.95	-9.25	58.50	44.70	73.96	53.96	-9.26
7387.20	1.00	125	62.29	51.09	-9.58	52.71	41.51	73.96	53.96	-12.45
9851.47	1.00	300	64.52	50.35	-7.56	56.96	42.79	73.96	53.96	-11.17
12291.21	1.00	157	73.40	53.58	-11.57	61.83	42.01	73.96	53.96	-11.95

*Test mode: IEEE 802.11g CH11 for 1GHz to 26.5GHz [Vertical]*

<i>Frequency</i>	<i>Ant. H.</i>	<i>Table</i>	<i>Amplitude</i>		<i>Correction Factor</i>	<i>Corrected Amplitude</i>		<i>Limit</i>		<i>Margin</i>
			<i>Peak / Ave.</i>			<i>Peak / Ave.</i>		<i>Peak / Ave.</i>		
<i>MHz</i>	<i>m</i>	<i>degree</i>	<i>dBμV</i>		<i>dB/m</i>	<i>dBμV/m</i>		<i>dBμV/m</i>		<i>dB</i>
2304.45	1.00	165	47.32	25.83	8.94	56.26	34.77	73.96	53.96	-17.70
2383.56	1.00	137	47.34	27.17	9.16	56.50	36.33	73.96	53.96	-17.46
2547.36	1.00	151	46.84	27.17	9.58	56.42	36.75	73.96	53.96	-17.21
2619.48	1.00	164	43.84	25.67	9.71	53.55	35.38	73.96	53.96	-18.58
4920.95	1.00	146	70.97	54.37	-9.25	61.72	45.12	73.96	53.96	-8.84
7382.59	1.00	193	61.60	51.35	-9.57	52.03	41.78	73.96	53.96	-12.18
9848.71	1.00	113	62.64	50.30	-7.55	55.09	42.75	73.96	53.96	-11.21
12301.83	1.00	94	71.01	53.89	-11.61	59.40	42.28	73.96	53.96	-11.68

*Test mode: IEEE 802.11n 20M CH01 for 30MHz to 1GHz [Horizontal]*

<b>Radiated Emission</b>				<b>Correction Factors</b>	<b>Corrected Amplitude</b>	<b>Class B (3 m)</b>	
<b>Frequency (MHz)</b>	<b>Amplitude (dBμV)</b>	<b>Ant. H. (m)</b>	<b>Table ( )</b>			<b>Limit (dBμV/m)</b>	<b>Margin (dB)</b>
102.75	37.85	1.00	316	-1.10	36.75	43.50	-6.75
196.60	43.89	1.00	135	-2.92	40.97	43.50	-2.53
209.45	37.63	1.00	145	-2.73	34.90	43.50	-8.60
260.37	41.18	1.00	178	-3.48	37.70	46.00	-8.30
299.50	42.56	1.00	178	-2.82	39.74	46.00	-6.26
949.08	22.83	1.00	290	15.33	38.16	46.00	-7.84

*Test mode: IEEE 802.11n 20M CH01 for 30MHz to 1GHz [Vertical]*

<b>Radiated Emission</b>				<b>Correction Factors</b>	<b>Corrected Amplitude</b>	<b>Class B (3 m)</b>	
<b>Frequency (MHz)</b>	<b>Amplitude (dBμV)</b>	<b>Ant. H. (m)</b>	<b>Table ( )</b>			<b>Limit (dBμV/m)</b>	<b>Margin (dB)</b>
101.54	37.61	1.00	135	-1.04	36.57	43.50	-6.93
198.54	34.94	1.00	84	-2.85	32.09	43.50	-11.41
300.39	37.02	1.00	148	-2.83	34.19	46.00	-11.81
432.55	38.61	1.00	279	0.16	38.77	46.00	-7.23
696.87	31.49	1.00	273	9.30	40.79	46.00	-5.21
947.86	24.25	1.00	59	15.32	39.57	46.00	-6.43

Test mode: IEEE 802.11n 20M CH01 for 1GHz to 26.5GHz [Horizontal]

Frequency	Ant. H.	Table	Amplitude		Correction Factor	Corrected Amplitude		Limit		Margin
			Peak / Ave.			Peak / Ave.		Peak / Ave.		
MHz	m	degree	dBµV		dB/m	dBµV/m		dBµV/m		dB
2258.19	1.00	129	48.49	36.17	8.81	57.30	44.98	73.96	53.96	-8.98
2340.09	1.00	128	55.99	43.50	9.04	65.03	52.54	73.96	53.96	-1.42
2499.12	1.00	128	54.48	42.83	9.49	63.97	52.32	73.96	53.96	-1.64
2576.41	1.00	100	51.67	39.00	9.63	61.30	48.63	73.96	53.96	-5.33
4824.04	1.00	153	62.71	55.51	-9.16	53.55	46.35	73.96	53.96	-7.61
7235.04	1.00	184	61.53	53.44	-9.41	52.12	44.03	73.96	53.96	-9.93
9651.43	1.00	106	63.38	52.63	-6.73	56.65	45.90	73.96	53.96	-8.06
12060.68	1.00	119	69.40	57.21	-10.65	58.75	46.56	73.96	53.96	-7.40

Test mode: IEEE 802.11n 20M CH01 for 1GHz to 26.5GHz [Vertical]

Frequency	Ant. H.	Table	Amplitude		Correction Factor	Corrected Amplitude		Limit		Margin
			Peak / Ave.			Peak / Ave.		Peak / Ave.		
MHz	m	degree	dBµV		dB/m	dBµV/m		dBµV/m		dB
2324.53	1.00	114	49.17	37.67	9.00	58.17	46.67	73.96	53.96	-7.29
2493.70	1.00	114	49.18	36.83	9.47	58.65	46.30	73.96	53.96	-7.66
2573.29	1.00	114	45.31	34.50	9.63	54.94	44.13	73.96	53.96	-9.83
4824.32	1.00	111	64.23	57.38	-9.16	55.07	48.22	73.96	53.96	-5.74
7238.61	1.00	149	61.89	53.75	-9.42	52.47	44.33	73.96	53.96	-9.63
9642.08	1.00	131	61.96	52.67	-6.69	55.27	45.98	73.96	53.96	-7.98
12061.54	1.00	95	68.26	56.21	-10.65	57.61	45.56	73.96	53.96	-8.40

*Test mode: IEEE 802.11n 20M CH06 for 30MHz to 1GHz [Horizontal]*

<b>Radiated Emission</b>				<b>Correction Factors</b> (dB)	<b>Corrected Amplitude</b> (dBμV/m)	<b>Class B (3 m)</b>	
<b>Frequency (MHz)</b>	<b>Amplitude (dBμV)</b>	<b>Ant. H. (m)</b>	<b>Table ( )</b>			<b>Limit (dBμV/m)</b>	<b>Margin (dB)</b>
101.54	36.55	1.00	326	-1.04	35.51	43.50	-7.99
196.60	43.60	1.00	145	-2.92	40.68	43.50	-2.82
257.95	40.85	1.00	219	-3.46	37.39	46.00	-8.61
298.86	44.43	1.00	168	-2.81	41.62	46.00	-4.38
368.29	37.85	1.00	168	-1.80	36.05	46.00	-9.95
949.08	22.60	1.00	346	15.33	37.93	46.00	-8.07

*Test mode: IEEE 802.11n 20M CH06 for 30MHz to 1GHz [Vertical]*

<b>Radiated Emission</b>				<b>Correction Factors</b> (dB)	<b>Corrected Amplitude</b> (dBμV/m)	<b>Class B (3 m)</b>	
<b>Frequency (MHz)</b>	<b>Amplitude (dBμV)</b>	<b>Ant. H. (m)</b>	<b>Table ( )</b>			<b>Limit (dBμV/m)</b>	<b>Margin (dB)</b>
100.32	37.07	1.00	110	-0.98	36.09	43.50	-7.41
167.01	32.61	1.00	182	-3.66	28.95	43.50	-14.55
198.54	35.64	1.00	24	-2.85	32.79	43.50	-10.71
390.60	37.66	1.00	144	-2.81	34.85	46.00	-11.15
502.87	28.50	1.00	127	3.08	31.58	46.00	-14.42
696.87	34.31	1.00	273	6.30	40.61	46.00	-5.39

Test mode: IEEE 802.11n 20M CH06 for 1GHz to 26.5GHz [Horizontal]

Frequency	Ant. H.	Table	Amplitude		Correction Factor	Corrected Amplitude		Limit		Margin
			Peak / Ave.			Peak / Ave.		Peak / Ave.		
MHz	m	degree	dBμV		dB/m	dBμV/m		dBμV/m		dB
2272.97	1.00	114	48.66	35.83	8.85	57.51	44.51	73.96	53.96	-9.28
2349.10	1.00	129	54.84	43.50	9.07	63.91	52.91	73.96	53.96	-1.39
2526.81	1.00	128	56.66	43.17	9.54	66.20	52.20	73.96	53.96	-1.25
2592.22	1.00	100	49.85	37.17	9.66	59.51	46.51	73.96	53.96	-7.13
4875.99	1.00	86	64.35	54.75	-9.21	55.14	45.54	73.96	53.96	-8.42
7312.87	1.00	116	61.29	52.88	-9.50	51.79	43.38	73.96	53.96	-10.58
9750.53	1.00	99	60.39	51.89	-7.14	53.25	44.75	73.96	53.96	-9.21
12182.45	1.00	98	64.12	55.50	-11.14	52.98	44.36	73.96	53.96	-9.60

Test mode: IEEE 802.11n 20M CH06 for 1GHz to 26.5GHz [Vertical]

Frequency	Ant. H.	Table	Amplitude		Correction Factor	Corrected Amplitude		Limit		Margin
			Peak / Ave.			Peak / Ave.		Peak / Ave.		
MHz	m	degree	dBμV		dB/m	dBμV/m		dBμV/m		dB
2346.55	1.00	254	48.00	38.00	9.06	57.06	47.06	73.96	53.96	-6.90
2526.55	1.00	69	48.15	38.83	9.54	57.69	48.37	73.96	53.96	-5.59
2594.09	1.00	69	43.84	33.67	9.67	53.51	43.34	73.96	53.96	-10.62
4871.11	1.00	43	67.19	56.00	-9.20	57.99	46.80	73.96	53.96	-7.16
7309.40	1.00	110	61.59	53.12	-9.49	52.10	43.63	73.96	53.96	-10.33
9750.42	1.00	70	60.40	51.63	-7.14	53.26	44.49	73.96	53.96	-9.47
12182.69	1.00	169	66.79	54.86	-11.14	55.65	43.72	73.96	53.96	-10.24

*Test mode: IEEE 802.11n 20M CH11 for 30MHz to 1GHz [Horizontal]*

<b>Radiated Emission</b>				<b>Correction Factors</b> (dB)	<b>Corrected Amplitude</b> (dBμV/m)	<b>Class B (3 m)</b>	
<b>Frequency (MHz)</b>	<b>Amplitude (dBμV)</b>	<b>Ant. H. (m)</b>	<b>Table ( )</b>			<b>Limit (dBμV/m)</b>	<b>Margin (dB)</b>
101.54	36.99	1.00	316	-1.04	35.95	43.50	-7.55
196.60	43.65	1.00	148	-2.92	40.73	43.50	-2.77
259.16	39.59	1.00	135	-3.48	36.11	46.00	-9.89
299.51	43.11	1.00	175	-2.82	40.29	46.00	-5.71
322.21	39.22	1.00	222	-2.61	36.61	46.00	-9.39
696.87	26.47	1.00	273	9.30	35.77	46.00	-10.23

*Test mode: IEEE 802.11n 20M CH11 for 30MHz to 1GHz [Vertical]*

<b>Radiated Emission</b>				<b>Correction Factors</b> (dB)	<b>Corrected Amplitude</b> (dBμV/m)	<b>Class B (3 m)</b>	
<b>Frequency (MHz)</b>	<b>Amplitude (dBμV)</b>	<b>Ant. H. (m)</b>	<b>Table ( )</b>			<b>Limit (dBμV/m)</b>	<b>Margin (dB)</b>
101.54	36.85	1.00	132	-1.04	35.81	43.50	-7.69
199.75	34.99	1.00	7	-2.81	32.18	43.50	-11.32
301.60	38.90	1.00	150	-2.81	36.09	46.00	-9.91
696.87	31.61	1.00	273	9.30	40.91	46.00	-5.09
798.72	23.32	1.00	66	12.04	35.36	46.00	-10.64
947.86	24.99	1.00	21	15.32	40.31	46.00	-5.69



Test mode: IEEE 802.11n 20M CH11 for 1GHz to 26.5GHz [Horizontal]

Frequency	Ant. H.	Table	Amplitude		Correction Factor	Corrected Amplitude		Limit		Margin
			Peak / Ave.			Peak / Ave.		Peak / Ave.		
MHz	m	degree	dB $\mu$ V		dB/m	dB $\mu$ V/m		dB $\mu$ V/m		dB
2304.47	1.00	290	49.17	37.33	8.94	58.11	46.27	73.96	53.96	-7.69
2374.81	1.00	290	52.50	41.00	9.14	61.64	50.14	73.96	53.96	-3.82
2549.18	1.00	128	54.34	43.00	9.58	63.92	52.58	73.96	53.96	-1.38
2613.63	1.00	90	49.34	38.83	9.70	59.04	48.53	73.96	53.96	-5.43
4923.80	1.00	18	63.39	54.91	-9.25	54.14	45.66	73.96	53.96	-8.30
7384.46	1.00	40	63.14	53.16	-9.58	53.56	43.58	73.96	53.96	-10.38
9849.15	1.00	307	64.58	51.48	-7.55	57.03	43.93	73.96	53.96	-10.03
12311.30	1.00	293	68.54	55.32	-11.65	56.89	43.67	73.96	53.96	-10.29

Test mode: IEEE 802.11n 20M CH11for 1GHz to 26.5GHz [Vertical]

Frequency	Ant. H.	Table	Amplitude		Correction Factor	Corrected Amplitude		Limit		Margin
			Peak / Ave.			Peak / Ave.		Peak / Ave.		
MHz	m	degree	dB $\mu$ V		dB/m	dB $\mu$ V/m		dB $\mu$ V/m		dB
2388.84	1.00	247	46.50	35.17	9.18	55.68	44.35	73.96	53.96	-9.61
2539.88	1.00	188	50.02	37.33	9.56	59.58	46.89	73.96	53.96	-7.07
2615.15	1.00	188	44.17	33.50	9.71	53.88	43.21	73.96	53.96	-10.75
4922.23	1.00	323	66.44	55.81	-9.25	57.19	46.56	73.96	53.96	-7.40
7385.11	1.00	105	61.20	53.52	-9.58	51.62	43.94	73.96	53.96	-10.02
9849.50	1.00	104	62.66	51.29	-7.55	55.11	43.74	73.96	53.96	-10.22
12312.69	1.00	114	68.78	54.25	-11.65	57.13	42.60	73.96	53.96	-11.36

#### **7.4 Test Result of the Bandedge**

If any 100 kHz bandwidth outside these frequency bands, the radio frequency power that is produced by the modulation products of the spreading sequence, the information sequence and the carrier frequency shall be either *at least 20 dB below that in any 100 kHz bandwidth within the band that contains the highest level of the desired power or shall not exceed the general levels specified in §15.209(a)*,

We perform this section by the *radiated manner*, the RBW is set to 100kHz and VBW>RBW. We'd made the observation *up to 10<sup>th</sup> harmonics and the criterion is all the harmonic/spurious emissions must be 20dB below the highest emission level measured*. If the emissions fall in the restricted bands stated in the Part15.205(a) must also *comply with the radiated emission limits specified in Part15.209(a)*. (*Peak mode: RBW=VBW=1MHz, Average mode: RBW=1MHz; VBW=10Hz*)

The following pages show our observations referring to the channel 1 and 11 respectively.

Test Condition & Setup: same as < 8.1 >

**Channel 1 of IEEE 802.11b**

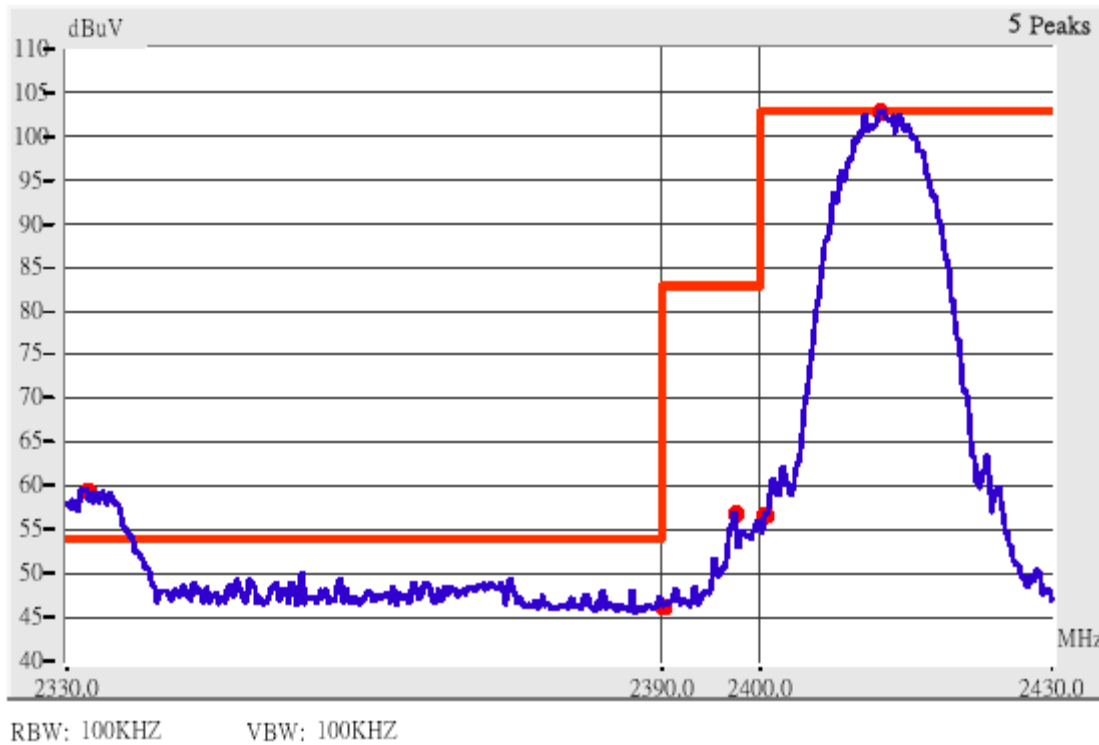

This is the hard copy of our bandedge measurement generated by our bandedge testing program. The plot shown above is the bandedge of channel 1.

1. The lobe left by the fundamental side is already 20dB below the highest emission level.
2. The emissions recorded in the restricted band is do comply with the Part 15.209(a) – as below.

<i>Radiated Emission</i>					<i>Corrected Amplitude</i>		<i>Class B ( 3m )</i>		
<i>Frequency (MHz)</i>	<i>Ant. P.</i>	<i>Ant. H. (m)</i>	<i>Table ( )</i>	<i>Factors (dB)</i>	<i>(dBµV/m)</i>		<i>Limit (dBµV/m)</i>		<i>Margin (dB)</i>
					<i>Peak</i>	<i>Average</i>	<i>Peak</i>	<i>Ave.</i>	
2332.83	Hor	1.00	144	9.02	68.44	50.59	73.96	53.96	-3.37
2348.61	Hor	1.00	61	9.07	60.12	42.65	73.96	53.96	-11.31
2390.88	Hor	1.00	292	9.18	56.88	41.82	73.96	53.96	-12.14
2331.45	Ver	1.00	123	9.02	58.79	43.98	73.96	53.96	-9.98
2370.88	Ver	1.00	163	9.13	52.33	37.38	73.96	53.96	-16.58
2389.44	Ver	1.00	63	9.18	49.73	36.29	73.96	53.96	-17.67

Channel 11 of IEEE 802.11b

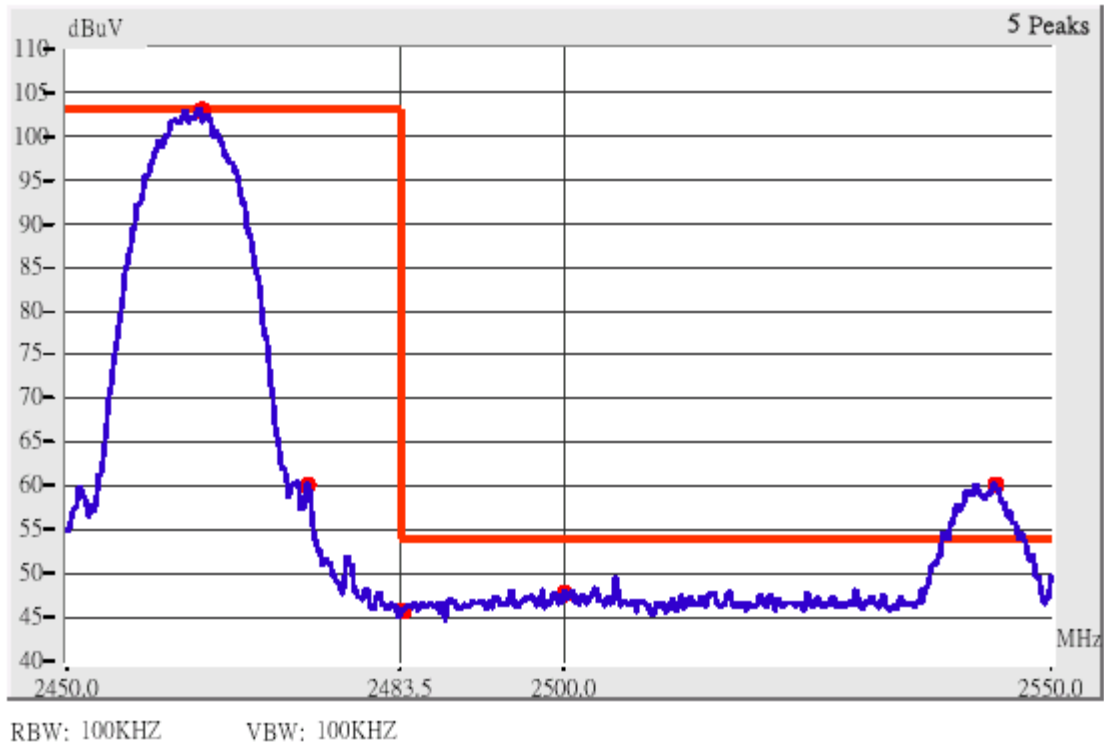

This is the hard copy of our bandedge measurement generated by our bandedge testing program. The plot shown above is the bandedge of channel 11.

- 3. The lobe right by the fundamental side is already 20dB below the highest emission level.
- 4. The emissions recorded in the restricted band is do comply with the Part 15.209(a) – as below

<i>Radiated Emission</i>					<i>Corrected Amplitude</i>		<i>Class B ( 3m )</i>		
<i>Frequency (MHz)</i>	<i>Ant. P.</i>	<i>Ant. H. (m)</i>	<i>Table ( ° )</i>	<i>Factors (dB)</i>	<i>(dBµV/m)</i>		<i>Limit (dBµV/m)</i>		<i>Margin (dB)</i>
					<i>Peak</i>	<i>Average</i>	<i>Peak</i>	<i>Ave.</i>	
2482.76	Hor	1.00	270	9.44	56.66	41.51	73.96	53.96	-12.45
2499.58	Hor	1.00	85	9.49	54.81	42.50	73.96	53.96	-11.46
2516.10	Hor	1.00	52	9.52	58.98	41.80	73.96	53.96	-12.16
2542.34	Hor	1.00	138	9.57	67.76	50.72	73.96	53.96	-3.24
2483.43	Ver	1.00	106	9.44	48.44	---	73.96	53.96	-5.52
2493.86	Ver	1.00	85	9.47	51.50	---	73.96	53.96	-2.46
2500.02	Ver	1.00	73	9.49	49.54	---	73.96	53.96	-4.42
2543.45	Ver	1.00	52	9.57	59.19	44.30	73.96	53.96	-9.66

**Channel 1 of IEEE 802.11g**

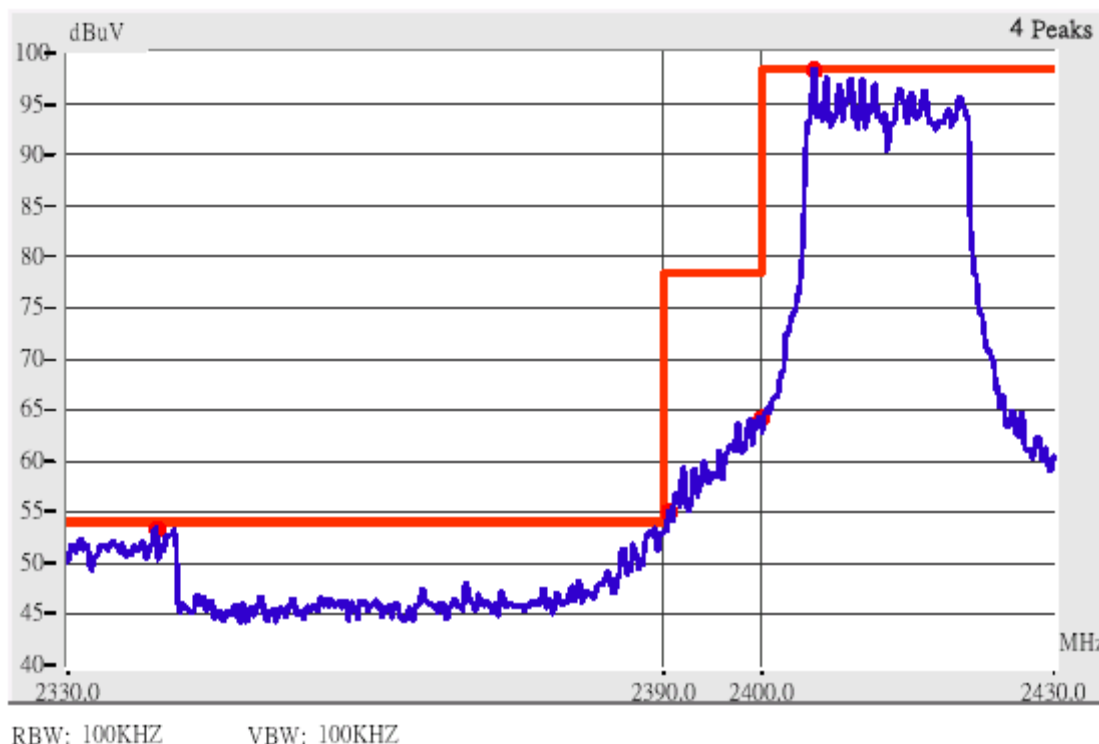

This is the hard copy of our bandedge measurement generated by our bandedge testing program. The plot shown above is the bandedge of channel 1.

- 5. The lobe left by the fundamental side is already 20dB below the highest emission level.
- 6. The emissions recorded in the restricted band is do comply with the Part 15.209(a) – as below.

<i>Radiated Emission</i>					<i>Corrected Amplitude</i>		<i>Class B ( 3m )</i>		
<i>Frequency (MHz)</i>	<i>Ant. P.</i>	<i>Ant. H. (m)</i>	<i>Table ( ° )</i>	<i>Factors (dB)</i>	<i>(dBµV/m)</i>		<i>Limit (dBµV/m)</i>		<i>Margin (dB)</i>
					<i>Peak</i>	<i>Average</i>	<i>Peak</i>	<i>Ave.</i>	
2338.89	Hor	1.00	195	9.04	66.71	38.37	73.96	53.96	-7.25
2381.68	Hor	1.00	93	9.16	66.83	36.99	73.96	53.96	-7.13
2390.45	Hor	1.00	81	9.18	69.85	39.01	73.96	53.96	-4.11
2339.14	Ver	1.00	251	9.04	60.37	36.87	73.96	53.96	-13.59
2384.76	Ver	1.00	151	9.17	58.67	35.34	73.96	53.96	-15.29
2389.74	Ver	1.00	147	9.18	64.18	36.68	73.96	53.96	-9.78

**Channel 11 of IEEE 802.11g**



This is the hard copy of our bandedge measurement generated by our bandedge testing program. The plot shown above is the bandedge of channel 11.

- 7. The lobe right by the fundamental side is already 20dB below the highest emission level.
- 8. The emissions recorded in the restricted band is do comply with the Part 15.209(a) – as below

<i>Radiated Emission</i>					<i>Corrected Amplitude</i>		<i>Class B ( 3m )</i>		
<i>Frequency (MHz)</i>	<i>Ant. P.</i>	<i>Ant. H. (m)</i>	<i>Table ( )</i>	<i>Factors (dB)</i>	<i>(dBµV/m)</i>		<i>Limit (dBµV/m)</i>		<i>Margin (dB)</i>
					<i>Peak</i>	<i>Average</i>	<i>Peak</i>	<i>Ave.</i>	
2483.26	Hor	1.00	173	9.44	70.94	38.94	73.96	53.96	-3.02
2487.18	Hor	1.00	190	9.45	66.45	37.78	73.96	53.96	-7.51
2499.74	Hor	1.00	190	9.49	59.49	37.16	73.96	53.96	-14.47
2537.94	Hor	1.00	84	9.56	68.23	38.89	73.96	53.96	-5.73
2483.21	Ver	1.00	279	9.44	66.44	36.94	73.96	53.96	-7.52
2485.38	Ver	1.00	273	9.45	63.62	36.28	73.96	53.96	-10.34
2500.01	Ver	1.00	263	9.49	50.16	---	73.96	53.96	-3.80
2543.19	Ver	1.00	167	9.57	59.91	36.57	73.96	53.96	-14.05

**Channel 01 of IEEE 802.11n 20M**

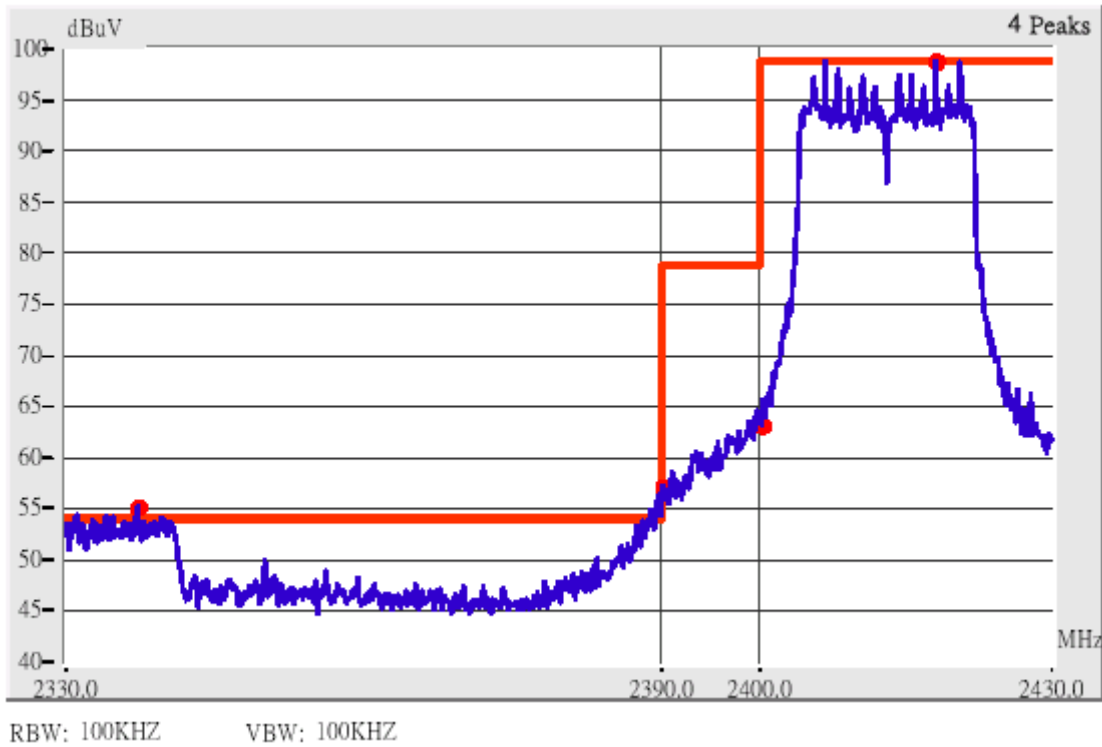

This is the hard copy of our bandedge measurement generated by our bandedge testing program. The plot shown above is the bandedge of channel 1.

- 9. The lobe left by the fundamental side is already 20dB below the highest emission level.
- 10. The emissions recorded in the restricted band do comply with the Part 15.209(a) – as below.

<i>Radiated Emission</i>					<i>Corrected Amplitude</i>		<i>Class B ( 3m )</i>		
<i>Frequency (MHz)</i>	<i>Ant. P.</i>	<i>Ant. H. (m)</i>	<i>Table ( ° )</i>	<i>Factors (dB)</i>	<i>(dBµV/m)</i>		<i>Limit (dBµV/m)</i>		<i>Margin (dB)</i>
					<i>Peak</i>	<i>Average</i>	<i>Peak</i>	<i>Ave.</i>	
2339.49	Hor	1.00	237	9.04	65.88	52.71	73.96	53.96	-1.25
2348.27	Hor	1.00	237	9.07	60.73	46.24	73.96	53.96	-7.72
2390.17	Hor	1.00	129	9.18	71.18	52.85	73.96	53.96	-1.11
2339.49	Ver	1.00	264	9.04	59.21	47.04	73.96	53.96	-6.92
2387.34	Ver	1.00	232	9.17	61.34	44.84	73.96	53.96	-9.12
2390.71	Ver	1.00	139	9.18	66.02	48.51	73.96	53.96	-5.45

**Channel 11 of IEEE 802.11n 20M**

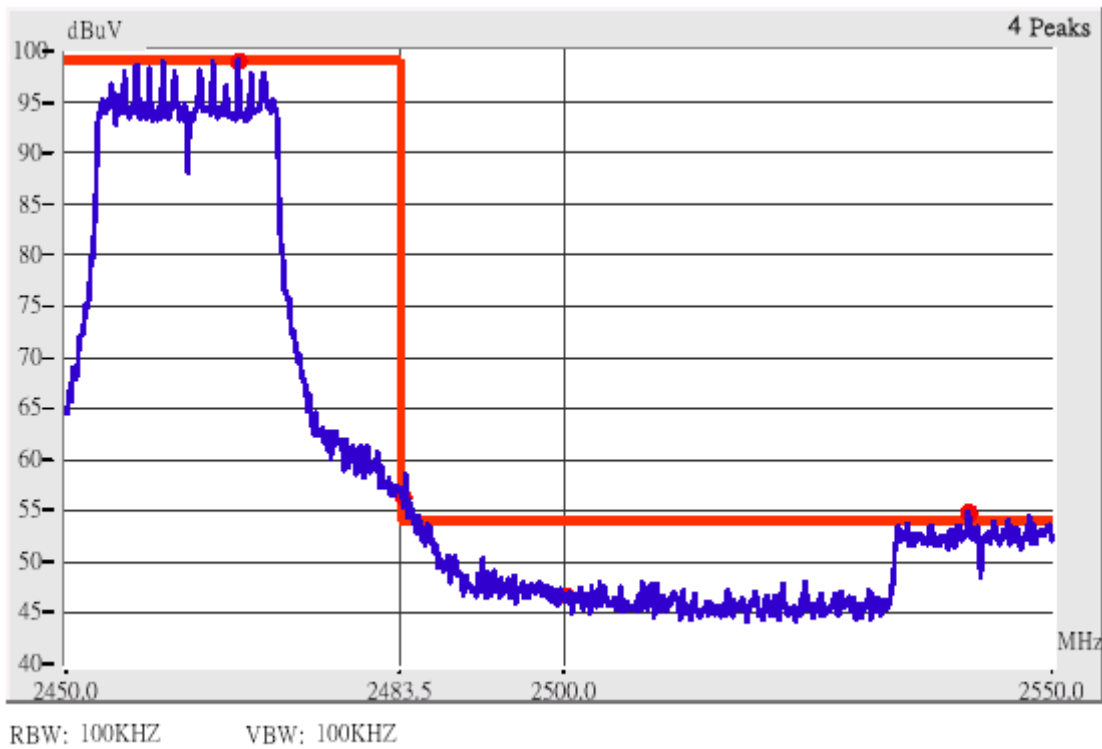

This is the hard copy of our bandedge measurement generated by our bandedge testing program. The plot shown above is the bandedge of channel 11.

- 11.The lobe right by the fundamental side is already 20dB below the highest emission level.
- 12.The emissions recorded in the restricted band is do comply with the Part 15.209(a) – as below

<i>Radiated Emission</i>					<i>Corrected Amplitude</i>		<i>Class B ( 3m )</i>		
<i>Frequency (MHz)</i>	<i>Ant. P.</i>	<i>Ant. H. (m)</i>	<i>Table ( )</i>	<i>Factors (dB)</i>	<i>(dBµV/m)</i>		<i>Limit (dBµV/m)</i>		<i>Margin (dB)</i>
					<i>Peak</i>	<i>Average</i>	<i>Peak</i>	<i>Ave.</i>	
2483.24	Hor	1.00	221	9.44	72.28	52.27	73.96	53.96	-1.68
2484.49	Hor	1.00	225	9.45	69.95	51.28	73.96	53.96	-2.68
2499.48	Hor	1.00	201	9.49	59.49	46.16	73.96	53.96	-7.80
2533.88	Hor	1.00	129	9.55	64.89	52.05	73.96	53.96	-1.91
2482.95	Ver	1.00	0	9.44	64.44	46.77	73.96	53.96	-7.19
2485.80	Ver	1.00	0	9.45	61.12	43.78	73.96	53.96	-10.18
2500.01	Ver	1.00	73	9.49	50.16	---	73.96	53.96	-3.80
2534.23	Ver	1.00	267	9.55	58.39	47.05	73.96	53.96	-6.91



## VIII. Section 15.247(d): Power Spectral Density

### 8.1 Test Condition & Setup

The tests below are running with the EUT transmitter set at high power in TDD mode. The EUT is needed to force selection of output power level and channel number. While testing, the EUT was set to transmit continuously and to be tested by the contact manner with the spectrum analyzer.

### 8.2 Test Instruments Configuration

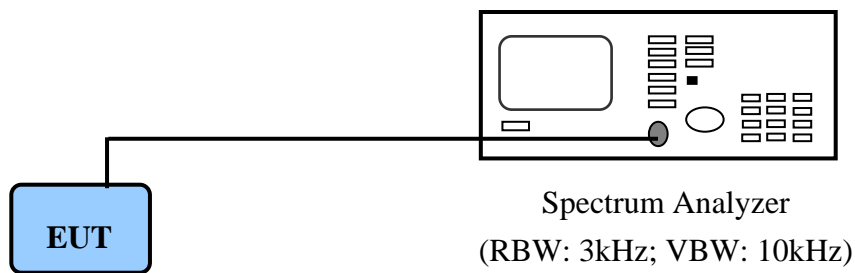

*PC to control the EUT at maximal power output and channel number and set antenna kit*

### 8.3 List of Test Instruments

Instrument Name	Model No.	Brand	Serial No.	Next time
Spectrum Analyzer	MS2665C	ANRITSU	6200175476	03/15/12

### 8.4 Test Result of Power spectral density

The following table shows a summary of the test results of the Power Spectral Density.

#### IEEE 802.11b

<i>Channel</i>	<i>Ppr</i> (dBm)	<i>Cable Loss</i> (dB)	<i>Ppq</i> (dBm)	<i>Limit</i> (dB)	<i>Margin</i> (dB)
CH 01	-10.13	7.00	-3.13	8.00	-11.13
CH 06	-10.35	7.00	-3.35	8.00	-11.35
CH 11	-10.75	7.00	-3.75	8.00	-11.75

#### IEEE 802.11g

<i>Channel</i>	<i>Ppr</i> (dBm)	<i>Cable Loss</i> (dB)	<i>Ppq</i> (dBm)	<i>Limit</i> (dB)	<i>Margin</i> (dB)
CH 01	-18.27	7.00	-11.27	8.00	-19.27
CH 06	-19.22	7.00	-12.22	8.00	-20.22
CH 11	-18.51	7.00	-11.51	8.00	-19.51

#### IEEE 802.11n 20M

<i>Channel</i>	<i>Ppr</i> (dBm)	<i>Cable Loss</i> (dB)	<i>Ppq</i> (dBm)	<i>Limit</i> (dB)	<i>Margin</i> (dB)
CH 01	-18.53	7.00	-11.53	8.00	-19.53
CH 06	-17.93	7.00	-10.93	8.00	-18.93
CH 11	-18.85	7.00	-11.85	8.00	-19.85

Note:

1. The following pages show the results of spectrum reading.
2. Ppr: spectrum read power density (using peak search mode),  
Ppq: actual peak power density in the spread spectrum band.
3.  $Ppq = Ppr + |Cable Loss|$

**Power Spectral Density for IEEE 802.11b Channel 01, 2412MHz**

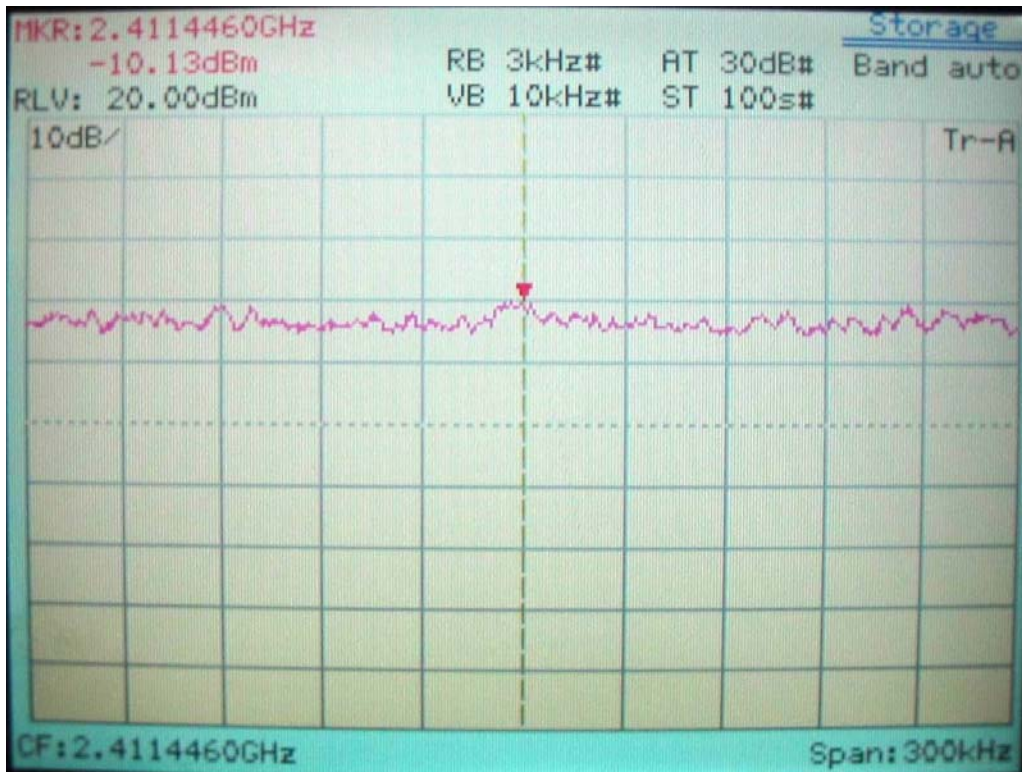

**Power Spectral Density for IEEE 802.11b Channel 06, 2437MHz**

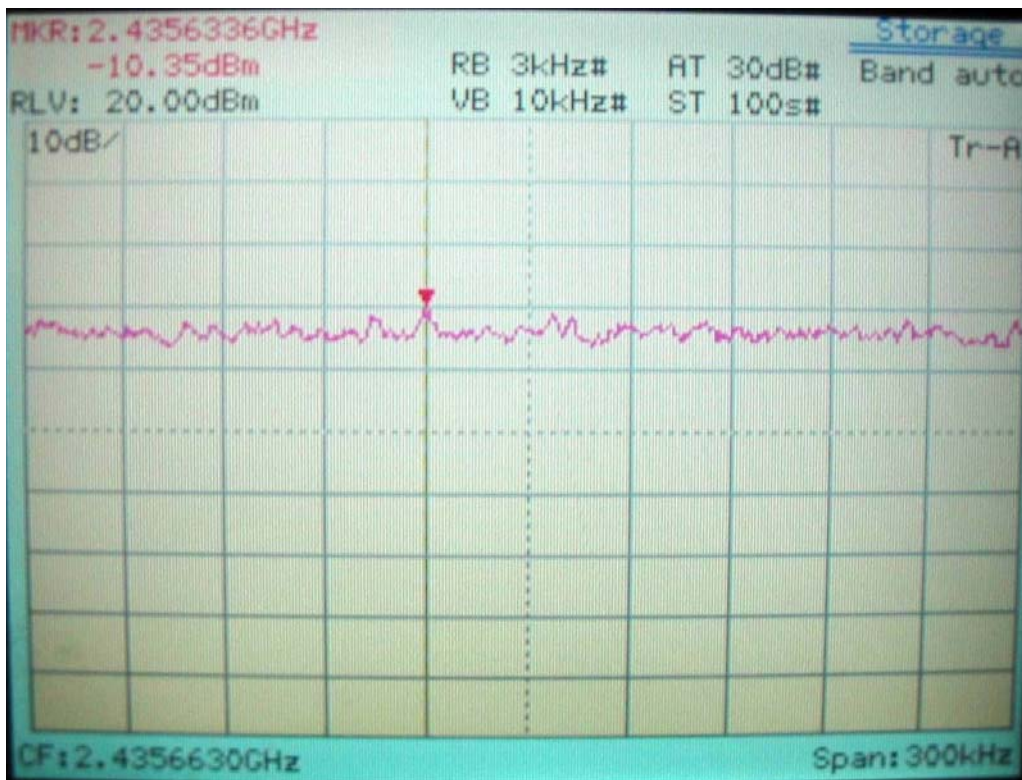

**Power Spectral Density for IEEE 802.11b Channel 11, 2462MHz**

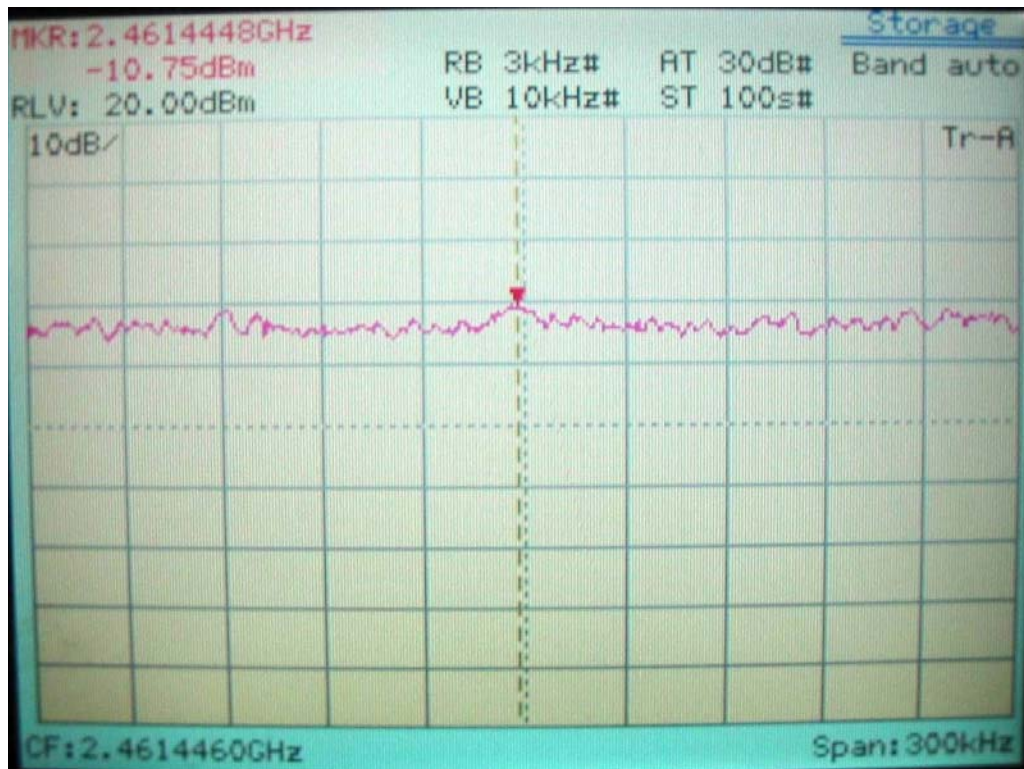

**Power Spectral Density for IEEE 802.11g Channel 01, 2412MHz**

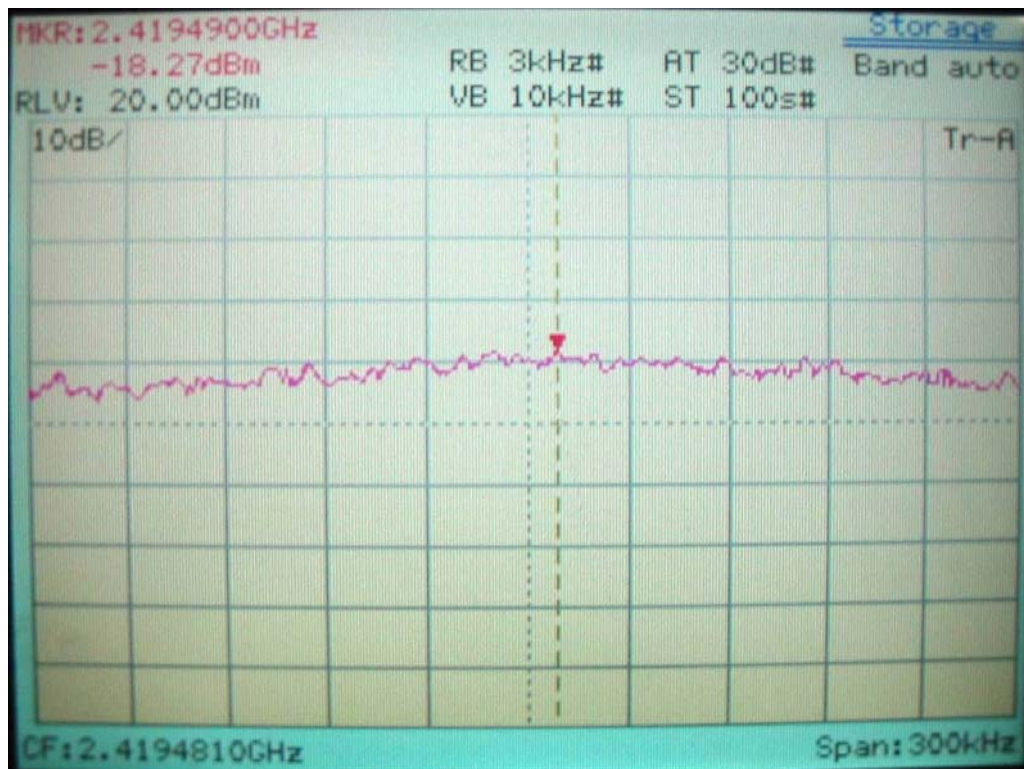

**Power Spectral Density for IEEE 802.11g Channel 06, 2437MHz**

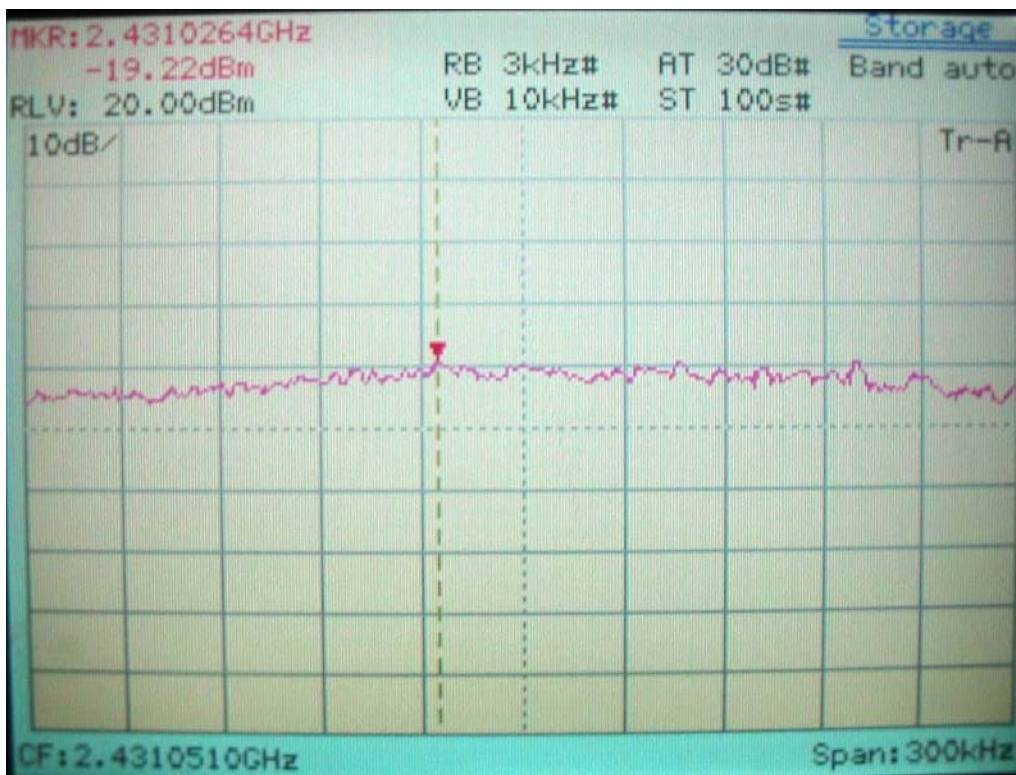

**Power Spectral Density for IEEE 802.11g Channel 11, 2462MHz**

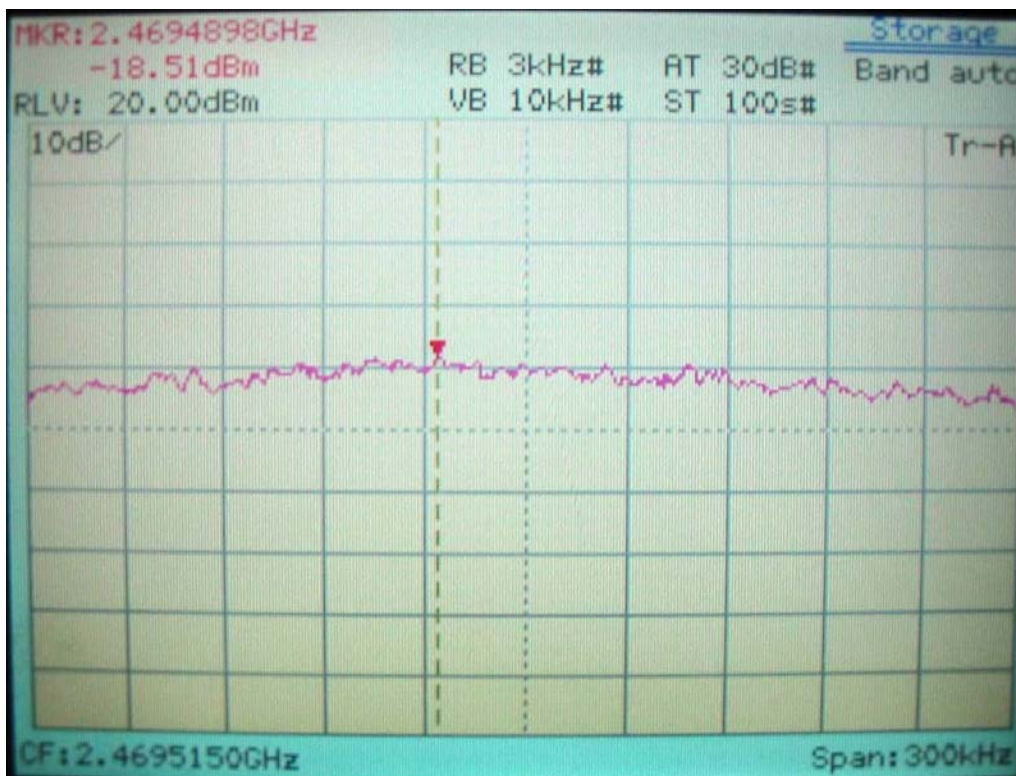

Power Spectral Density for IEEE 802.11n 20M Channel 01, 2412MHz

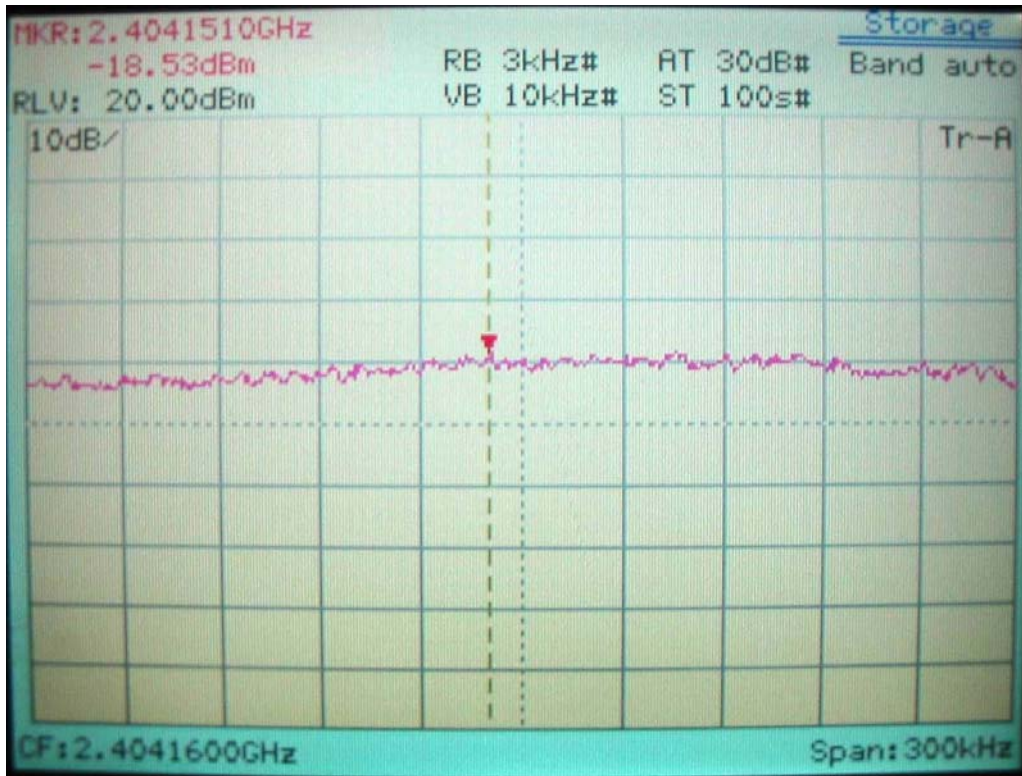

Power Spectral Density for IEEE 802.11n 20M Channel 06, 2437MHz

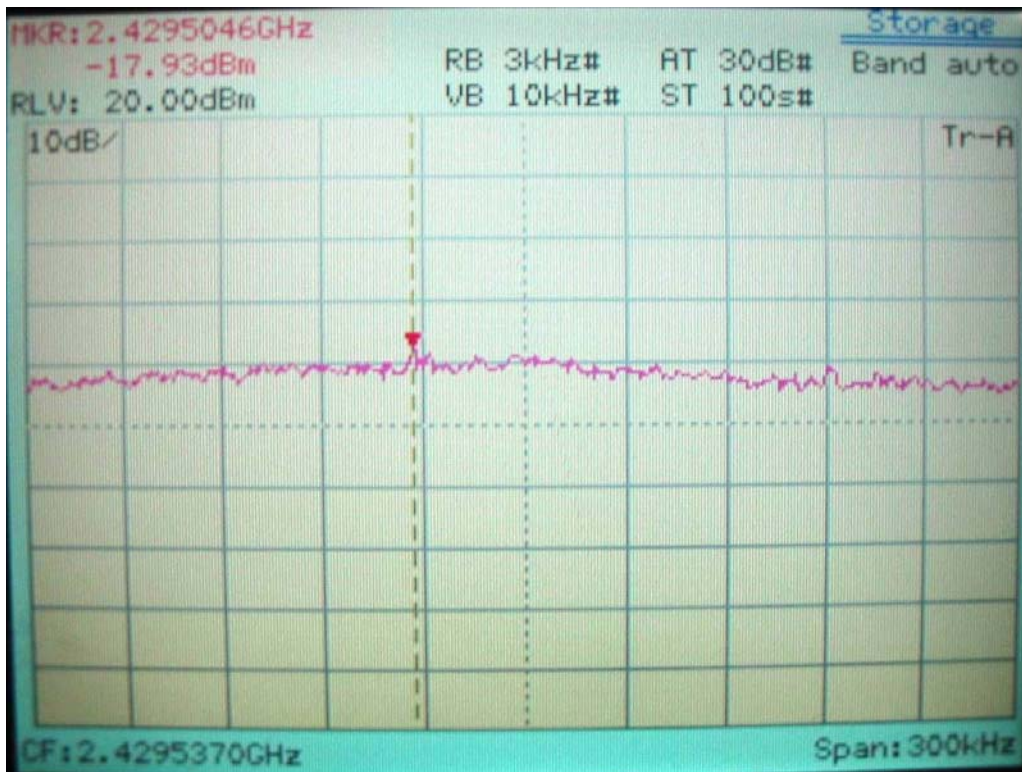

Power Spectral Density for IEEE 802.11n 20M Channel 11, 2462MHz

