

Wi-Fi 2.4GHz Band

Frequency: 2437 MHz; Duty Cycle: 1:1; Room Ambient Temperature: 24.0°C; Liquid Temperature: 23.5°C

Medium parameters used (interpolated): $f = 2437$ MHz; $\sigma = 1.95$ S/m; $\epsilon_r = 53.931$; $\rho = 1000$ kg/m³

DASY5 Configuration:

- Area Scan Setting - Find Secondary Maximum Within: 2.0 dB and with a peak SAR value greater than 0.0012W/kg
- Electronics: DAE4 Sn877; Calibrated: 2014/03/26
- Probe: EX3DV4 - SN3665; ConvF(7.22, 7.22, 7.22); Calibrated: 2014/05/22;
- Sensor-Surface: 1.4mm (Mechanical Surface Detection)
- Phantom: ELI 4.0; Type: QDOVA001BA; Serial: 1056

Rear/Main Ant/802.11b/Ch6/Area Scan (6x7x1): Measurement grid: dx=12mm, dy=12mm

[Info: Interpolated medium parameters used for SAR evaluation.](#)

Maximum value of SAR (measured) = 0.369 W/kg

Rear/Main Ant/802.11b/Ch6/Zoom Scan (7x7x7)/Cube 0: Measurement grid: dx=5mm, dy=5mm, dz=5mm

Reference Value = 7.764 V/m; Power Drift = -0.07 dB

Peak SAR (extrapolated) = 0.430 W/kg

SAR(1 g) = 0.186 W/kg; SAR(10 g) = 0.092 W/kg

[Info: Interpolated medium parameters used for SAR evaluation.](#)

Maximum value of SAR (measured) = 0.332 W/kg

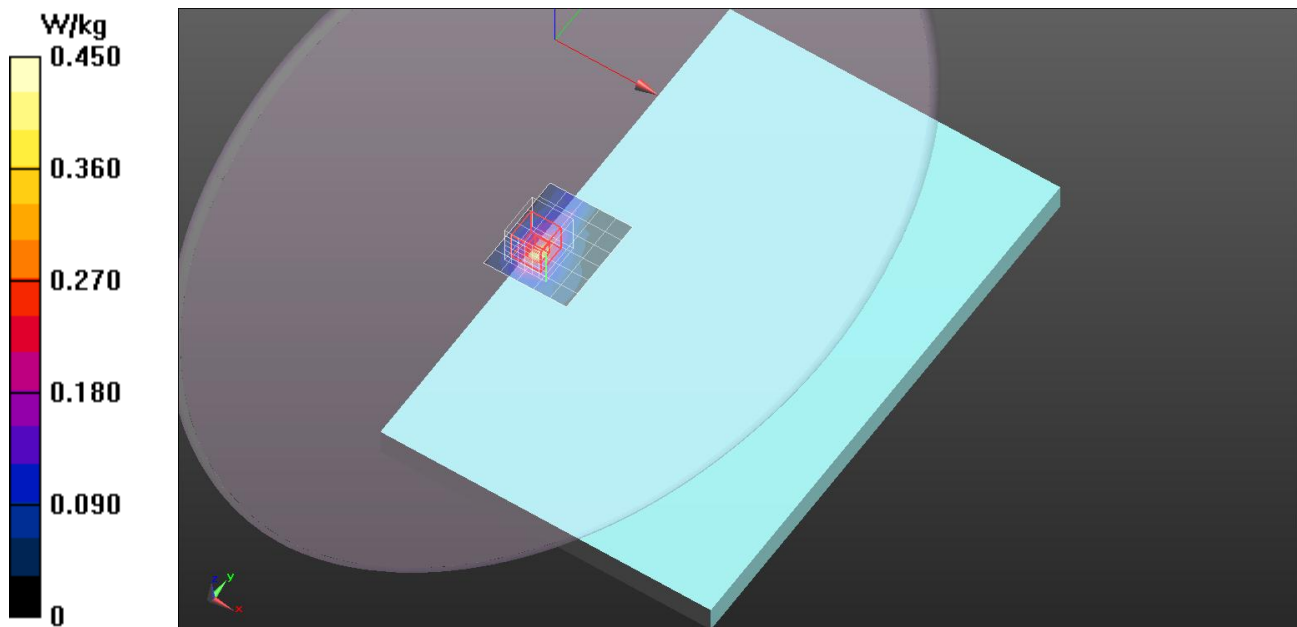

Wi-Fi 2.4GHz Band

Frequency: 2437 MHz; Duty Cycle: 1:1; Room Ambient Temperature: 24.0°C; Liquid Temperature: 23.5°C

Medium parameters used (interpolated): $f = 2437$ MHz; $\sigma = 1.95$ S/m; $\epsilon_r = 53.931$; $\rho = 1000$ kg/m³

DASY5 Configuration:

- Area Scan Setting - Find Secondary Maximum Within: 2.0 dB and with a peak SAR value greater than 0.0012W/kg
- Electronics: DAE4 Sn877; Calibrated: 2014/03/26
- Probe: EX3DV4 - SN3665; ConvF(7.22, 7.22, 7.22); Calibrated: 2014/05/22;
- Sensor-Surface: 1.4mm (Mechanical Surface Detection)
- Phantom: ELI 4.0; Type: QDOVA001BA; Serial: 1056

Edge3/Main Ant/802.11b/Ch6/Area Scan (6x7x1): Measurement grid: dx=12mm, dy=12mm

[Info: Interpolated medium parameters used for SAR evaluation.](#)

Maximum value of SAR (measured) = 0.583 W/kg

Edge3/Main Ant/802.11b/Ch6/Zoom Scan (7x7x7)/Cube 0: Measurement grid: dx=5mm, dy=5mm, dz=5mm

Reference Value = 17.04 V/m; Power Drift = 0.04 dB

Peak SAR (extrapolated) = 0.860 W/kg

SAR(1 g) = 0.396 W/kg; SAR(10 g) = 0.190 W/kg

[Info: Interpolated medium parameters used for SAR evaluation.](#)

Maximum value of SAR (measured) = 0.674 W/kg

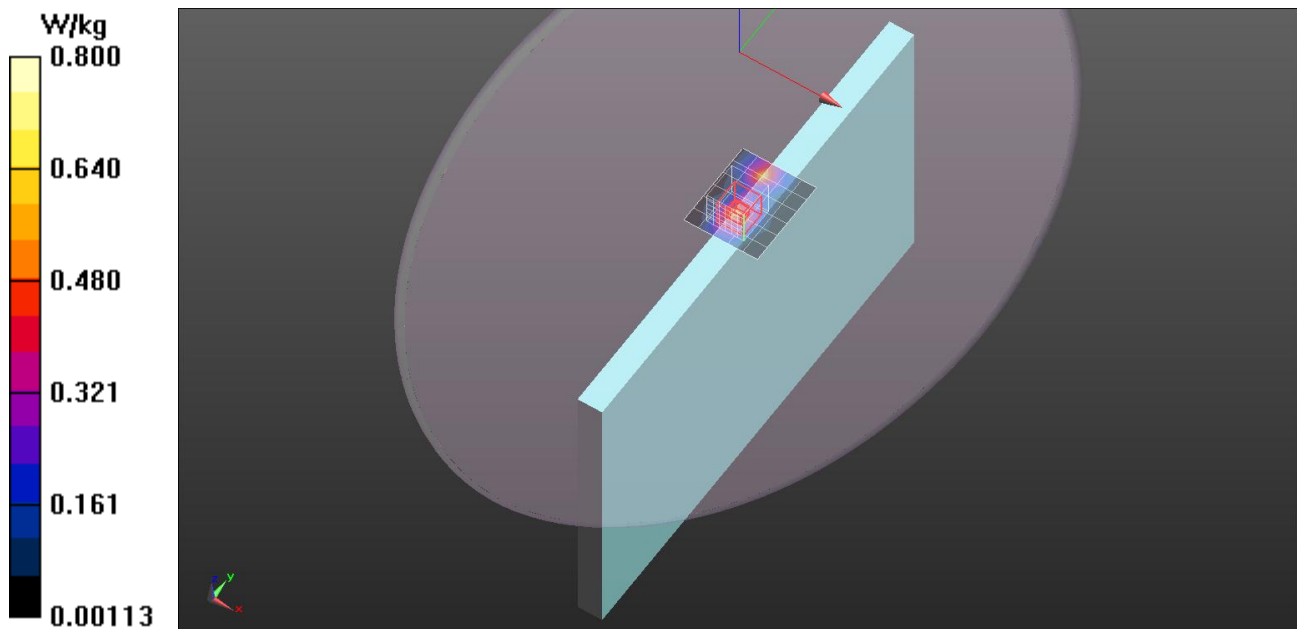

Wi-Fi 2.4GHz Band

Frequency: 2437 MHz; Duty Cycle: 1:1; Room Ambient Temperature: 24.0°C; Liquid Temperature: 23.5°C

Medium parameters used (interpolated): $f = 2437$ MHz; $\sigma = 1.95$ S/m; $\epsilon_r = 53.931$; $\rho = 1000$ kg/m³

DASY5 Configuration:

- Area Scan Setting - Find Secondary Maximum Within: 2.0 dB and with a peak SAR value greater than 0.0012W/kg
- Electronics: DAE4 Sn877; Calibrated: 2014/03/26
- Probe: EX3DV4 - SN3665; ConvF(7.22, 7.22, 7.22); Calibrated: 2014/05/22;
- Sensor-Surface: 1.4mm (Mechanical Surface Detection)
- Phantom: ELI 4.0; Type: QDOVA001BA; Serial: 1056

Edge3/Main Ant/802.11b/Ch6_Ant 2/Area Scan (6x7x1): Measurement grid: dx=12mm, dy=12mm

[Info: Interpolated medium parameters used for SAR evaluation.](#)

Maximum value of SAR (measured) = 1.65 W/kg

Edge3/Main Ant/802.11b/Ch6_Ant 2/Zoom Scan (7x7x7)/Cube 0: Measurement grid: dx=5mm, dy=5mm, dz=5mm

Reference Value = 29.97 V/m; Power Drift = -0.07 dB

Peak SAR (extrapolated) = 2.18 W/kg

Peak SAR (extrapolated) = 2.18 W/kg

SAR(1 g) = 1.01 W/kg; SAR(10 g) = 0.476 W/kg

[Info: Interpolated medium parameters used for SAR evaluation.](#)

Maximum value of SAR (measured) = 1.69 W/kg

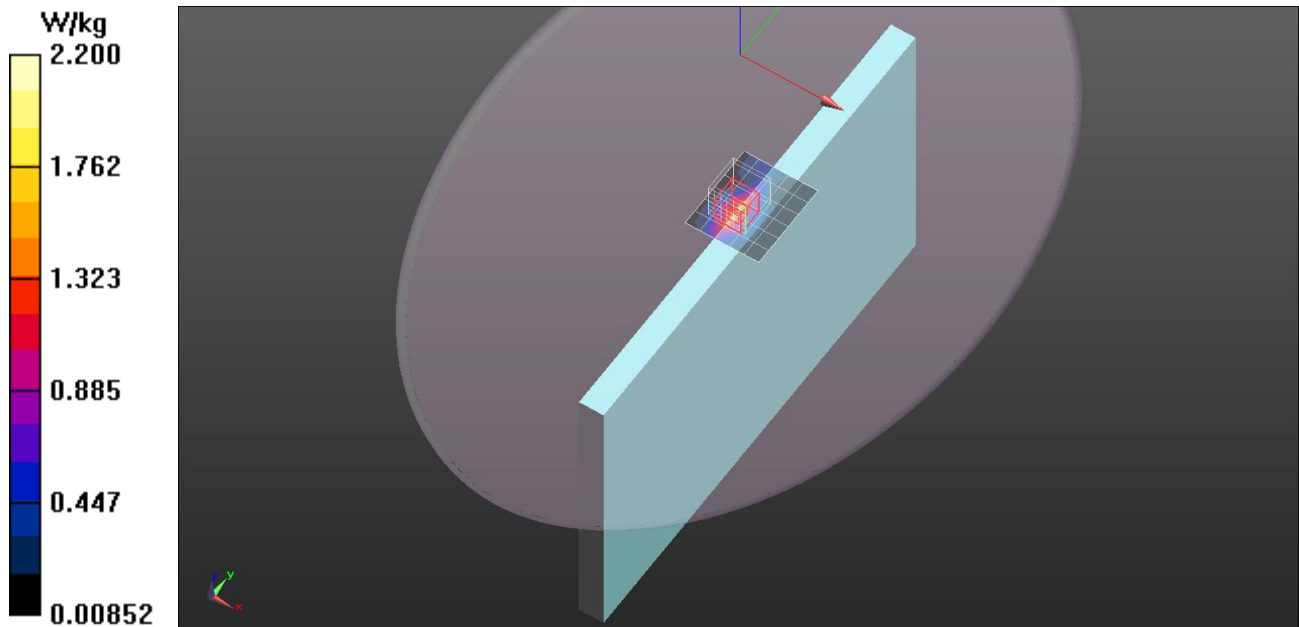

Wi-Fi 2.4GHz Band

Frequency: 2437 MHz; Duty Cycle: 1:1

Edge3/Main Ant/802.11b/Ch6_Ant 2/Z Scan (1x1x21): Measurement grid: dx=20mm, dy=20mm, dz=5mm

Info: [Interpolated medium parameters used for SAR evaluation.](#)

Maximum value of SAR (measured) = 1.67 W/kg

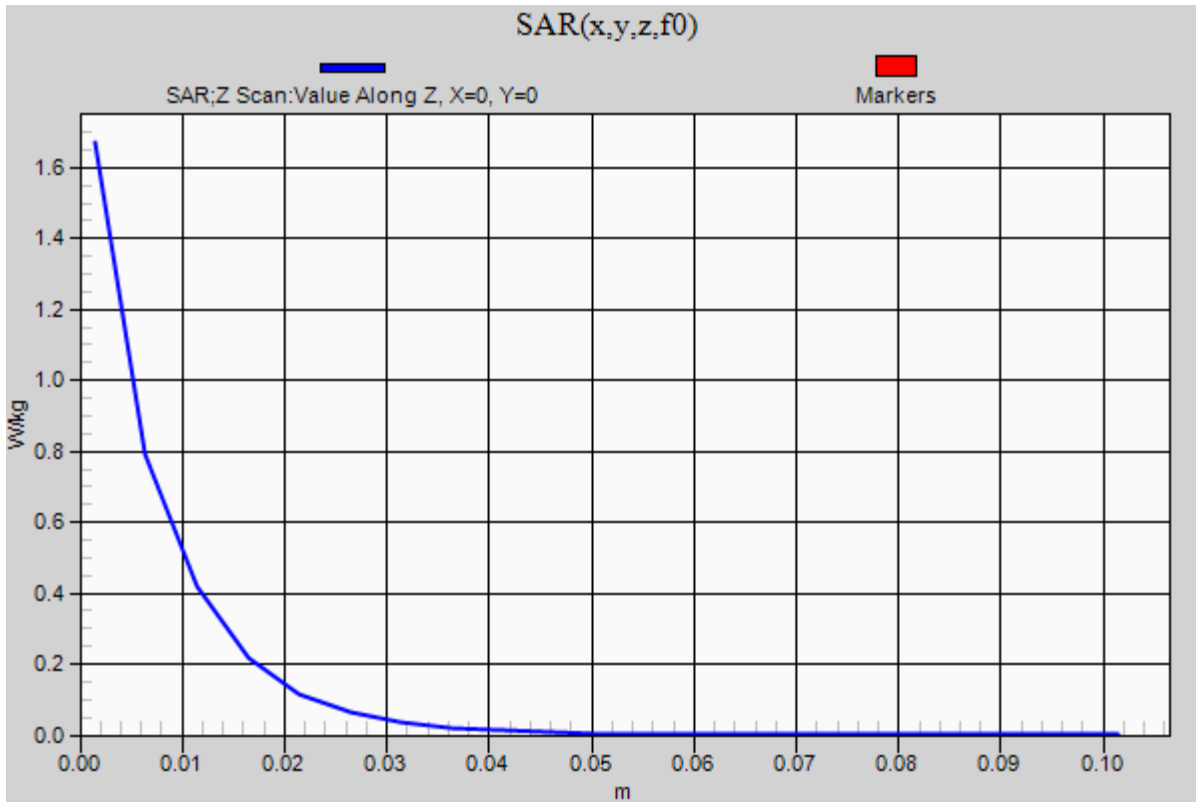

Wi-Fi 2.4GHz Band

Frequency: 2412 MHz; Duty Cycle: 1:1; Room Ambient Temperature: 24.0°C; Liquid Temperature: 23.5°C

Medium parameters used: $f = 2412.7$ MHz; $\sigma = 1.875$ S/m; $\epsilon_r = 52.143$; $\rho = 1000$ kg/m³

DASY5 Configuration:

- Area Scan Setting - Find Secondary Maximum Within: 2.0 dB and with a peak SAR value greater than 0.0012W/kg
- Electronics: DAE4 Sn1305; Calibrated: 2014/12/11
- Probe: EX3DV4 - SN3665; ConvF(7.22, 7.22, 7.22); Calibrated: 2014/05/22;
- Sensor-Surface: 1.4mm (Mechanical Surface Detection)
- Phantom: ELI 4.0; Type: QDOVA001BA; Serial: 1056

Edge3/Main Ant/802.11b/Ch1_Ant 2/Area Scan (6x7x1): Measurement grid: dx=12mm, dy=12mm

Maximum value of SAR (measured) = 0.820 W/kg

Edge3/Main Ant/802.11b/Ch1_Ant 2/Zoom Scan (7x7x7)/Cube 0: Measurement grid: dx=5mm, dy=5mm, dz=5mm

Reference Value = 19.55 V/m; Power Drift = 0.05 dB

Peak SAR (extrapolated) = 1.90 W/kg

Peak SAR (extrapolated) = 1.90 W/kg

SAR(1 g) = 0.885 W/kg; SAR(10 g) = 0.426 W/kg

Maximum value of SAR (measured) = 1.50 W/kg

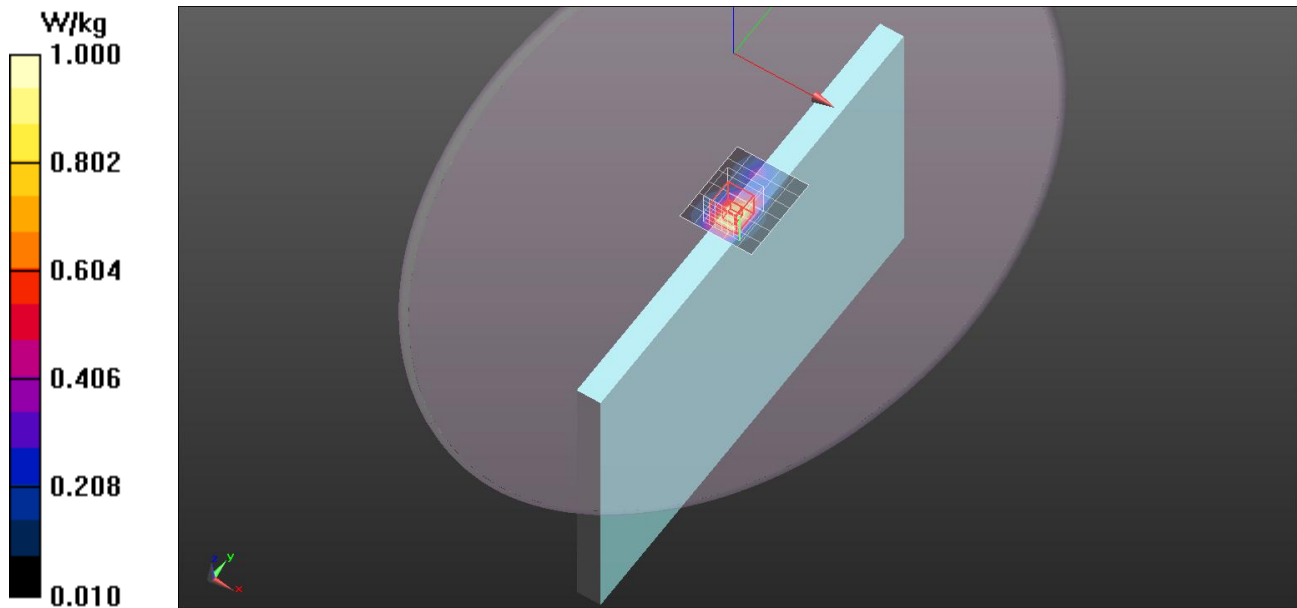

Wi-Fi 2.4GHz Band

Frequency: 2462 MHz; Duty Cycle: 1:1; Room Ambient Temperature: 24.0°C; Liquid Temperature: 23.5°C

Medium parameters used: $f = 2462.2$ MHz; $\sigma = 1.94$ S/m; $\epsilon_r = 51.98$; $\rho = 1000$ kg/m³

DASY5 Configuration:

- Area Scan Setting - Find Secondary Maximum Within: 2.0 dB and with a peak SAR value greater than 0.0012W/kg
- Electronics: DAE4 Sn1305; Calibrated: 2014/12/11
- Probe: EX3DV4 - SN3665; ConvF(7.22, 7.22, 7.22); Calibrated: 2014/05/22;
- Sensor-Surface: 1.4mm (Mechanical Surface Detection (Locations From Previous Scan Used)), Sensor-Surface: 1.4mm (Mechanical Surface Detection)
- Phantom: ELI 4.0; Type: QDOVA001BA; Serial: 1056

Edge3/Main Ant/802.11b/Ch11_Ant 2/Area Scan (6x7x1): Measurement grid: dx=12mm, dy=12mm

Maximum value of SAR (measured) = 1.17 W/kg

Edge3/Main Ant/802.11b/Ch11_Ant 2/Zoom Scan (7x7x7)/Cube 0: Measurement grid: dx=5mm, dy=5mm, dz=5mm

Reference Value = 22.02 V/m; Power Drift = -0.18 dB

Peak SAR (extrapolated) = 1.70 W/kg

Peak SAR (extrapolated) = 1.70 W/kg

SAR(1 g) = 0.779 W/kg; SAR(10 g) = 0.373 W/kg

Maximum value of SAR (measured) = 1.33 W/kg

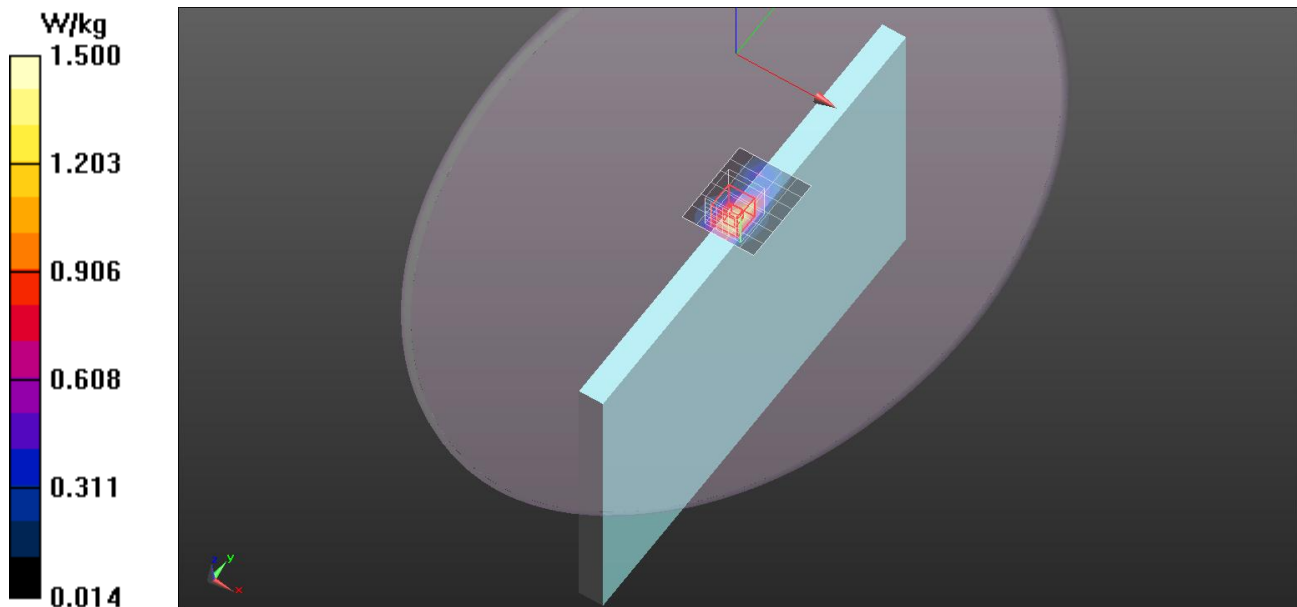

Wi-Fi 2.4GHz Band

Frequency: 2437 MHz; Duty Cycle: 1:1; Room Ambient Temperature: 24.0°C; Liquid Temperature: 23.5°C

Medium parameters used (interpolated): $f = 2437$ MHz; $\sigma = 1.906$ S/m; $\epsilon_r = 52.069$; $\rho = 1000$ kg/m³

DASY5 Configuration:

- Area Scan Setting - Find Secondary Maximum Within: 2.0 dB and with a peak SAR value greater than 0.0012W/kg
- Electronics: DAE4 Sn1305; Calibrated: 2014/12/11
- Probe: EX3DV4 - SN3665; ConvF(7.22, 7.22, 7.22); Calibrated: 2014/05/22;
- Sensor-Surface: 1.4mm (Mechanical Surface Detection (Locations From Previous Scan Used)), Sensor-Surface: 1.4mm (Mechanical Surface Detection)
- Phantom: ELI 4.0; Type: QDOVA001BA; Serial: 1056

Edge3/Main Ant/802.11b/Ch6_Ant 2_Repeat/Area Scan (6x7x1): Measurement grid: dx=12mm, dy=12mm

[Info: Interpolated medium parameters used for SAR evaluation.](#)

Maximum value of SAR (measured) = 1.18 W/kg

Edge3/Main Ant/802.11b/Ch6_Ant 2_Repeat/Zoom Scan (7x7x7)/Cube 0: Measurement grid:

dx=5mm, dy=5mm, dz=5mm

Reference Value = 22.20 V/m; Power Drift = -0.19 dB

Peak SAR (extrapolated) = 1.92 W/kg

SAR(1 g) = 0.891 W/kg; SAR(10 g) = 0.428 W/kg

[Info: Interpolated medium parameters used for SAR evaluation.](#)

Maximum value of SAR (measured) = 1.52 W/kg

