



FCC TEST REPORT (15.407)

REPORT NO.: RF131126C13-1

MODEL NO.: OUYA1P

FCC ID: VUI-OUYA1P

RECEIVED: Nov. 26, 2013

TESTED: Dec. 12 ~ Dec. 20, 2013

ISSUED: Dec. 20, 2013

APPLICANT: PEGATRON CORPORATION

ADDRESS: 5F., NO. 76, LIGONG ST., BEITOU DISTRICT,
TAIPEI CITY 112, TAIWAN (R.O.C.)

ISSUED BY: Bureau Veritas Consumer Products Services
(H.K.) Ltd., Taoyuan Branch

LAB ADDRESS: No. 47, 14th Ling, Chia Pau Vil., Lin Kou Dist.,
New Taipei City, Taiwan, R.O.C.

TEST LOCATION: No. 19, Hwa Ya 2nd Rd, Wen Hwa Tsuen, Kwei
Shan Hsiang, Taoyuan Hsien 333, Taiwan, R.O.C.

This report should not be used by the client to claim product certification, approval, or endorsement by TAF or any government agencies.



This report is for your exclusive use. Any copying or replication of this report to or for any other person or entity, or use of our name or trademark, is permitted only with our prior written permission. This report sets forth our findings solely with respect to the test samples identified herein. The results set forth in this report are not indicative or representative of the quality or characteristics of the lot from which a test sample was taken or any similar or identical product unless specifically and expressly noted. Our report includes all of the tests requested by you and the results thereof based upon the information that you provided to us. You have 60 days from date of issuance of this report to notify us of any material error or omission caused by our negligence, provided, however, that such notice shall be in writing and shall specifically address the issue you wish to raise. A failure to raise such issue within the prescribed time shall constitute your unqualified acceptance of the completeness of this report, the tests conducted and the correctness of the report contents. Unless specific mention, the uncertainty of measurement has been explicitly taken into account to declare the compliance or non-compliance to the specification.



TABLE OF CONTENTS

RELEASE CONTROL RECORD	4
1. CERTIFICATION.....	5
2. SUMMARY OF TEST RESULTS	6
2.1 MEASUREMENT UNCERTAINTY	6
3. GENERAL INFORMATION.....	7
3.1 GENERAL DESCRIPTION OF EUT	7
3.2 DESCRIPTION OF TEST MODES.....	9
3.2.1 TEST MODE APPLICABILITY AND TESTED CHANNEL DETAIL.....	10
3.3 DUTY CYCLE OF TEST SIGNAL.....	12
3.4 DESCRIPTION OF SUPPORT UNITS	16
3.4.1 CONFIGURATION OF SYSTEM UNDER TEST	16
3.5 GENERAL DESCRIPTION OF APPLIED STANDARDS	16
4. TEST TYPES AND RESULTS	17
4.1 RADIATED EMISSION AND BANDEDGE MEASUREMENT	17
4.1.1 LIMITS OF RADIATED EMISSION AND BANDEDGE MEASUREMENT.....	17
4.1.2 LIMITS OF UNWANTED EMISSION OUT OF THE RESTRICTED BANDS	17
4.1.3 TEST INSTRUMENTS.....	18
4.1.4 TEST PROCEDURES	19
4.1.5 DEVIATION FROM TEST STANDARD	19
4.1.6 TEST SETUP.....	20
4.1.7 EUT OPERATING CONDITION	20
4.1.8 TEST RESULTS	21
4.2 CONDUCTED EMISSION MEASUREMENT	47
4.2.1 LIMITS OF CONDUCTED EMISSION MEASUREMENT	47
4.2.2 TEST INSTRUMENTS.....	47
4.2.3 TEST PROCEDURES	48
4.2.4 DEVIATION FROM TEST STANDARD	48
4.2.5 TEST SETUP.....	48
4.2.6 EUT OPERATING CONDITIONS	48
4.2.7 TEST RESULTS	49
4.3 PEAK TRANSMIT POWER MEASUREMENT	51
4.3.1 LIMITS OF PEAK TRANSMIT POWER MEASUREMENT	51
4.3.2 TEST SETUP.....	51
4.3.3 TEST INSTRUMENTS.....	52
4.3.4 TEST PROCEDURE.....	52
4.3.5 DEVIATION FROM TEST STANDARD	52
4.3.6 EUT OPERATING CONDITIONS	52
4.3.7 TEST RESULTS	53
4.4 PEAK POWER SPECTRAL DENSITY MEASUREMENT	58
4.4.1 LIMITS OF PEAK POWER SPECTRAL DENSITY MEASUREMENT	58
4.4.2 TEST SETUP.....	58
4.4.3 TEST INSTRUMENTS.....	58
4.4.4 TEST PROCEDURES	59
4.4.5 DEVIATION FROM TEST STANDARD	59
4.4.6 EUT OPERATING CONDITIONS	59
4.4.7 TEST RESULTS	60
4.5 PEAK POWER EXCURSION MEASUREMENT	62



A D T

4.5.1	LIMITS OF PEAK POWER EXCURSION MEASUREMENT	62
4.5.2	TEST SETUP	62
4.5.3	TEST INSTRUMENTS.....	62
4.5.4	TEST PROCEDURE.....	62
4.5.5	DEVIATION FROM TEST STANDARD	62
4.5.6	EUT OPERATING CONDITIONS	62
4.5.7	TEST RESULTS	63
4.6	FREQUENCY STABILITY	64
4.6.1	LIMITS OF FREQUENCY STABILITY MEASUREMENT.....	64
4.6.2	TEST SETUP.....	64
4.6.3	TEST INSTRUMENTS.....	64
4.6.4	TEST PROCEDURE.....	65
4.6.5	DEVIATION FROM TEST STANDARD	65
4.6.6	EUT OPERATING CONDITION	65
4.6.7	TEST RESULTS	66
5.	PHOTOGRAPHS OF THE TEST CONFIGURATION	67
6.	INFORMATION ON THE TESTING LABORATORIES.....	68
7.	APPENDIX A - MODIFICATIONS RECORDERS FOR ENGINEERING CHANGES TO THE EUT BY THE LAB	69



A D T

RELEASE CONTROL RECORD

ISSUE NO.	REASON FOR CHANGE	DATE ISSUED
RF131126C13-1	Original release	Dec. 20, 2013



1. CERTIFICATION

PRODUCT: Game Console

MODEL: OUYA1P

BRAND: OUYA

APPLICANT: PEGATRON CORPORATION

TESTED: Dec. 12 ~ Dec. 20, 2013

TEST SAMPLE: ENGINEERING SAMPLE

STANDARDS: FCC Part 15, Subpart E (Section 15.407)

ANSI C63.10-2009

The above equipment (model: OUYA1P) has been tested by **Bureau Veritas Consumer Products Services (H.K.) Ltd., Taoyuan Branch**, and found compliance with the requirement of the above standards. The test record, data evaluation & Equipment Under Test (EUT) configurations represented herein are true and accurate accounts of the measurements of the sample's EMC characteristics under the conditions specified in this report.

PREPARED BY : Celine Chou , **DATE :** Dec. 20, 2013
Celine Chou / Specialist

APPROVED BY : Ken Liu , **DATE :** Dec. 20, 2013
Ken Liu / Senior Manager

2. SUMMARY OF TEST RESULTS

The EUT has been tested according to the following specifications:

APPLIED STANDARD: FCC PART 15, SUBPART E (SECTION 15.407)			
STANDARD SECTION	TEST TYPE	RESULT	REMARK
15.407(b)(6)	AC Power Conducted Emission	PASS	Meet the requirement of limit. Minimum passing margin is -18.87dB at 0.18170MHz.
15.407(b/1/2/3)(b)(6)	Radiated Emissions	PASS	Meet the requirement of limit. Minimum passing margin is -2.5dB at 5150.00MHz.
15.407(a/1/2)	Max Average Transmit Power	PASS	Meet the requirement of limit.
15.407(a)(6)	Peak Power Excursion	PASS	Meet the requirement of limit.
15.407(a/1/2)	Peak Power Spectral Density	PASS	Meet the requirement of limit.
15.407(g)	Frequency Stability	PASS	Meet the requirement of limit.
15.203	Antenna Requirement	PASS	No antenna connector is used.

2.1 MEASUREMENT UNCERTAINTY

Where relevant, the following measurement uncertainty levels have been estimated for tests performed on the EUT as specified in CISPR 16-4-2:

MEASUREMENT	FREQUENCY	UNCERTAINTY
Conducted emissions	9kHz~30MHz	2.44 dB
Radiated emissions	30MHz ~ 200MHz	3.19 dB
	200MHz ~1000MHz	3.21 dB
	1GHz ~ 18GHz	2.26 dB
	18GHz ~ 40GHz	1.94 dB

This uncertainty represents an expanded uncertainty expressed at approximately the 95% confidence level using a coverage factor of $k = 2$.

3. GENERAL INFORMATION

3.1 GENERAL DESCRIPTION OF EUT

EUT	Game Console
MODEL NO.	OUYA1P
POWER SUPPLY	12Vdc from adapter
MODULATION TYPE	64QAM, 16QAM, QPSK, BPSK
MODULATION TECHNOLOGY	OFDM
TRANSFER RATE	802.11a: 54.0/ 48.0/ 36.0/ 24.0/ 18.0/ 12.0/ 9.0/ 6.0Mbps 802.11n: up to 135.0Mbps
OPERATING FREQUENCY	5180 ~ 5240MHz, 5260 ~ 5320MHz & 5500 ~ 5700MHz
NUMBER OF CHANNEL	5180 ~ 5240MHz: 4 for 802.11a, 802.11n (20MHz) 2 for 802.11n (40MHz) 5260 ~ 5320MHz: 4 for 802.11a, 802.11n (20MHz) 2 for 802.11n (40MHz) 5500 ~ 5700MHz: 8 for 802.11a, 802.11n (20MHz) 3 for 802.11n (40MHz)
OUTPUT POWER	21.478mW for 5180 ~ 5240MHz 21.184mW for 5260 ~ 5320MHz 20.893mW for 5500 ~ 5700MHz
ANTENNA TYPE	PCB antenna with 4.49dBi gain
ANTENNA CONNECTOR	N/A
I/O PORTS	Refer to user's manual
DATA CABLE	N/A
ACCESSORY DEVICES	Adapter

NOTE:

- The following colors and capacities are provided to EUT.

Item	Color	Capacity
1	Black, White	8GB
2	Black, White	16GB

* Item 2 (White) was chosen for final test.

2. The EUT provides one completed transmitter and one receiver.

MODULATION MODE	TX FUNCTION
802.11b	1TX
802.11g	1TX
802.11a	1TX
802.11n (20MHz)	1TX
802.11n (40MHz)	1TX

3. The EUT consumes power from the following adapter.

BRAND	Ktec
MODEL	KSASB0241200150HU
INPUT POWER	100-240Vac, 50/60Hz, 0.6A
OUTPUT POWER	12Vdc, 1.5A
POWER LINE:	DC: 1.5m non-shielded cable without core

4. The above EUT information is declared by manufacturer and for more detailed features description, please refer to the manufacturer's specifications or user's manual.

3.2 DESCRIPTION OF TEST MODES

FOR 5180 ~ 5240MHz

4 channels are provided for 802.11a, 802.11n (20MHz):

CHANNEL	FREQUENCY	CHANNEL	FREQUENCY
36	5180 MHz	44	5220 MHz
40	5200 MHz	48	5240 MHz

2 channels are provided for 802.11n (40MHz):

CHANNEL	FREQUENCY	CHANNEL	FREQUENCY
38	5190 MHz	46	5230 MHz

FOR 5260 ~ 5320MHz

4 channels are provided for 802.11a, 802.11n (20MHz):

CHANNEL	FREQUENCY	CHANNEL	FREQUENCY
52	5260 MHz	60	5300 MHz
56	5280 MHz	64	5320 MHz

2 channels are provided for 802.11n (40MHz):

CHANNEL	FREQUENCY	CHANNEL	FREQUENCY
54	5270 MHz	62	5310 MHz

FOR 5500 ~ 5700MHz

8 channels are provided for 802.11a, 802.11n (20MHz):

CHANNEL	FREQUENCY	CHANNEL	FREQUENCY
100	5500 MHz	116	5580 MHz
104	5520 MHz	132	5660 MHz
108	5540 MHz	136	5680 MHz
112	5560 MHz	140	5700 MHz

3 channels are provided for 802.11n (40MHz):

CHANNEL	FREQUENCY	CHANNEL	FREQUENCY
102	5510 MHz	134	5670 MHz
110	5550 MHz		

3.2.1 TEST MODE APPLICABILITY AND TESTED CHANNEL DETAIL

EUT CONFIGURE MODE	APPLICABLE TO				DESCRIPTION
	RE \geq 1G	RE<1G	PLC	APCM	
-	√	√	√	√	-

Where **RE \geq 1G**: Radiated Emission above 1GHz **RE<1G**: Radiated Emission below 1GHz
PLC: Power Line Conducted Emission **APCM**: Antenna Port Conducted Measurement

NOTE: The EUT had been pre-tested four side of EUT. The worst case was found when side on **top**.

RADIATED EMISSION TEST (ABOVE 1GHz):

- Pre-Scan has been conducted to determine the worst-case mode from all possible combinations between available modulations, data rates and antenna ports (if EUT with antenna diversity architecture).
- Following channel(s) was (were) selected for the final test as listed below.

EUT CONFIGURE MODE	MODE	FREQ. BAND (MHz)	AVAILABLE CHANNEL	TESTED CHANNEL	MODULATION TECHNOLOGY	MODULATION TYPE	DATA RATE (Mbps)
-	802.11a	5180-5240	36 to 48	36, 40, 48	OFDM	BPSK	6.0
-	802.11n (20MHz)		36 to 48	36, 40, 48	OFDM	BPSK	6.5
-	802.11n (40MHz)		38 to 46	38, 46	OFDM	BPSK	13.5
-	802.11a	5260-5320	52 to 64	52, 60, 64	OFDM	BPSK	6.0
-	802.11n (20MHz)		52 to 64	52, 60, 64	OFDM	BPSK	6.5
-	802.11n (40MHz)		54 to 62	54, 62	OFDM	BPSK	13.5
-	802.11a	5500-5700	100 to 140	100, 116, 140	OFDM	BPSK	6.0
-	802.11n (20MHz)		100 to 140	100, 116, 140	OFDM	BPSK	6.5
-	802.11n (40MHz)		102 to 134	102, 110, 134	OFDM	BPSK	13.5

RADIATED EMISSION TEST (BELOW 1GHz):

- Pre-Scan has been conducted to determine the worst-case mode from all possible combinations between available modulations, data rates and antenna ports (if EUT with antenna diversity architecture).
- Following channel(s) was (were) selected for the final test as listed below.

EUT CONFIGURE MODE	MODE	FREQ. BAND (MHz)	AVAILABLE CHANNEL	TESTED CHANNEL	MODULATION TECHNOLOGY	MODULATION TYPE	DATA RATE (Mbps)
-	802.11a	5180-5240	36 to 48	48	OFDM	BPSK	6.0

POWER LINE CONDUCTED EMISSION TEST:

- Pre-Scan has been conducted to determine the worst-case mode from all possible combinations between available modulations, data rates and antenna ports (if EUT with antenna diversity architecture).
- Following channel(s) was (were) selected for the final test as listed below.

EUT CONFIGURE MODE	MODE	FREQ. BAND (MHz)	AVAILABLE CHANNEL	TESTED CHANNEL	MODULATION TECHNOLOGY	MODULATION TYPE	DATA RATE (Mbps)
-	802.11a	5180-5240	36 to 48	48	OFDM	BPSK	6.0

ANTENNA PORT CONDUCTED MEASUREMENT:

- This item includes all test value of each mode, but only includes spectrum plot of worst value of each mode.
- Pre-Scan has been conducted to determine the worst-case mode from all possible combinations between available modulations, data rates and antenna ports (if EUT with antenna diversity architecture).
- Following channel(s) was (were) selected for the final test as listed below.

EUT CONFIGURE MODE	MODE	FREQ. BAND (MHz)	AVAILABLE CHANNEL	TESTED CHANNEL	MODULATION TECHNOLOGY	MODULATION TYPE	DATA RATE (Mbps)
-	802.11a	5180-5240	36 to 48	36, 40, 48	OFDM	BPSK	6.0
-	802.11n (20MHz)		36 to 48	36, 40, 48	OFDM	BPSK	6.5
-	802.11n (40MHz)		38 to 46	38, 46	OFDM	BPSK	13.5
-	802.11a	5260-5320	52 to 64	52, 60, 64	OFDM	BPSK	6.0
-	802.11n (20MHz)		52 to 64	52, 60, 64	OFDM	BPSK	6.5
-	802.11n (40MHz)		54 to 62	54, 62	OFDM	BPSK	13.5
-	802.11a	5500-5700	100 to 140	100, 116, 140	OFDM	BPSK	6.0
-	802.11n (20MHz)		100 to 140	100, 116, 140	OFDM	BPSK	6.5
-	802.11n (40MHz)		102 to 134	102, 110, 134	OFDM	BPSK	13.5

TEST CONDITION:

APPLICABLE TO	ENVIRONMENTAL CONDITIONS	INPUT POWER	TESTED BY
RE≥1G	22deg. C, 69%RH	120Vac, 60Hz	Jones Chang
RE<1G	22deg. C, 69%RH	120Vac, 60Hz	Brad Tung
PLC	22deg. C, 66%RH	120Vac, 60Hz	Jones Chang
APCM	25deg. C, 60%RH	120Vac, 60Hz	Frank Liu

3.3 DUTY CYCLE OF TEST SIGNAL

MODULATION TYPE: BPSK

802.11a: Duty cycle of test signal is > 98 %, duty factor is not required.

802.11n (20MHz), 802.11n (40MHz): Duty cycle of test signal is < 98 %, duty factor is required

802.11n (20MHz): Duty cycle = $0.675/0.773 = 0.873$, Duty factor = $10 * \log(1/0.873) = 0.59$

802.11n (40MHz): Duty cycle = $0.944/0.972 = 0.971$, Duty factor = $10 * \log(1/0.971) = 0.13$

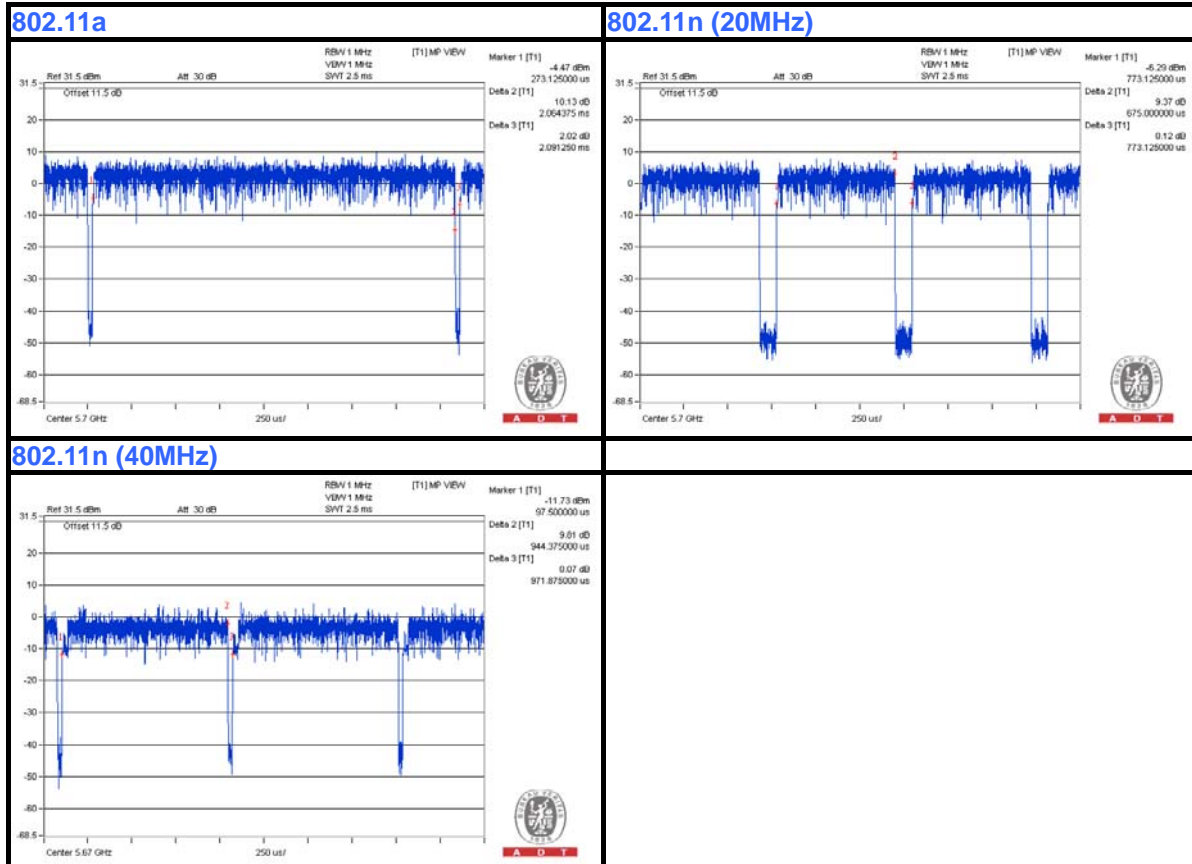



A D T

MODULATION TYPE: QPSK

Duty cycle of test signal is < 98 %, duty factor is required

802.11a: Duty cycle = $1.040/1.139 = 0.913$, Duty factor = $10 * \log(1/0.913) = 0.39$

802.11n (20MHz): Duty cycle = $0.257/0.356 = 0.722$, Duty factor = $10 * \log(1/0.722) = 1.42$

802.11n (40MHz): Duty cycle = $0.195/0.296 = 0.659$, Duty factor = $10 * \log(1/0.659) = 1.81$

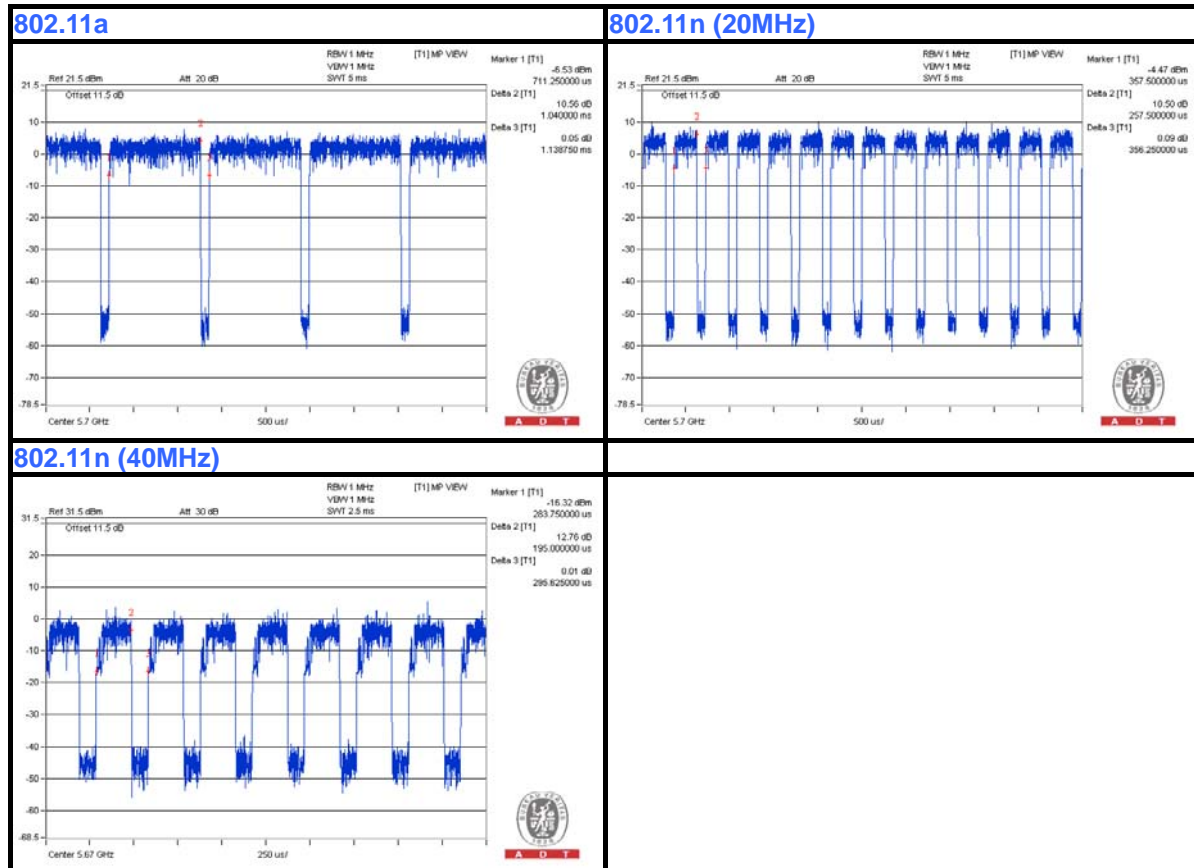



A D T

MODULATION TYPE: 16QAM

Duty cycle of test signal is < 98 %, duty factor is required

802.11a: Duty cycle = $0.530/0.629 = 0.843$, Duty factor = $10 * \log(1/0.843) = 0.74$

802.11n (20MHz): Duty cycle = $0.153/0.261 = 0.586$, Duty factor = $10 * \log(1/0.586) = 2.32$

802.11n (40MHz): Duty cycle = $0.122/0.222 = 0.550$, Duty factor = $10 * \log(1/0.550) = 2.60$

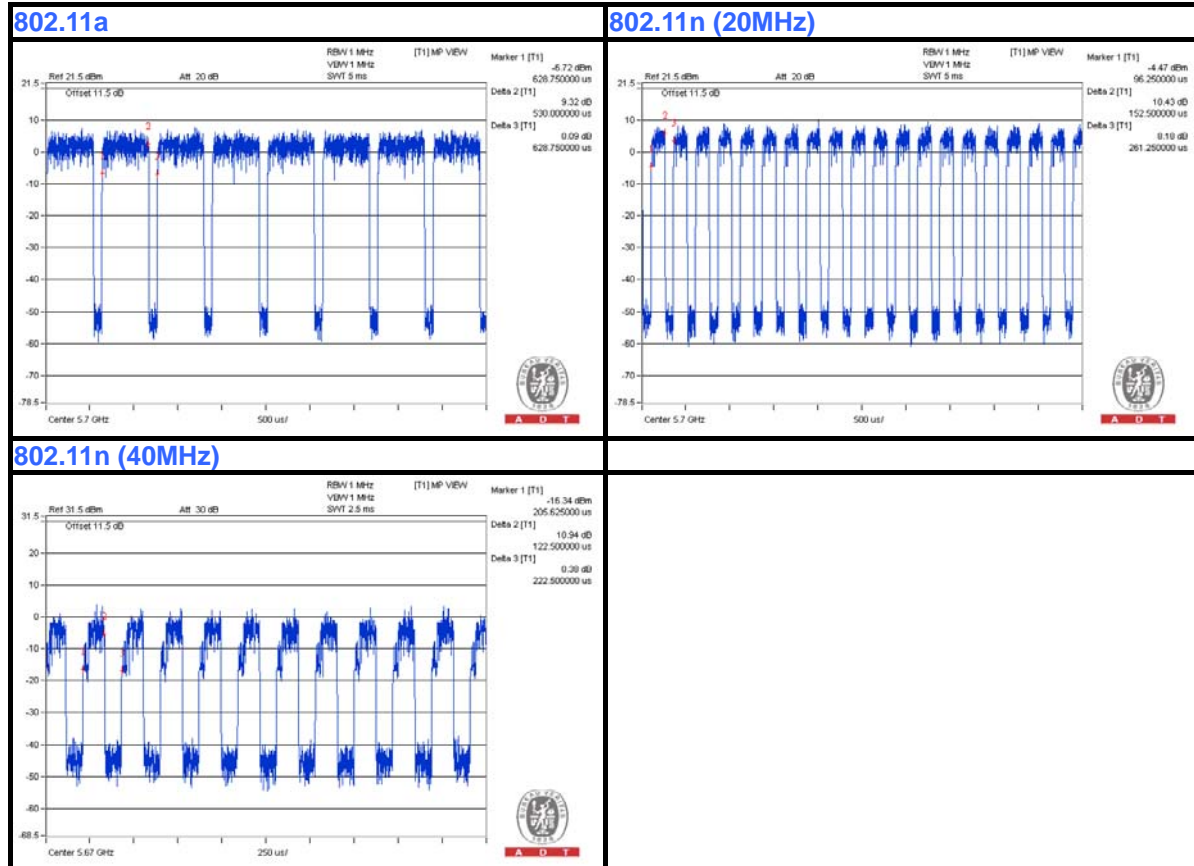



A D T

MODULATION TYPE: 64QAM

Duty cycle of test signal is < 98 %, duty factor is required

802.11a: Duty cycle = $0.274/0.372 = 0.737$, Duty factor = $10 * \log(1/0.737) = 1.33$

802.11n (20MHz): Duty cycle = $0.111/0.210 = 0.529$, Duty factor = $10 * \log(1/0.529) = 2.77$

802.11n (40MHz): Duty cycle = $0.084/0.183 = 0.459$, Duty factor = $10 * \log(1/0.459) = 3.38$

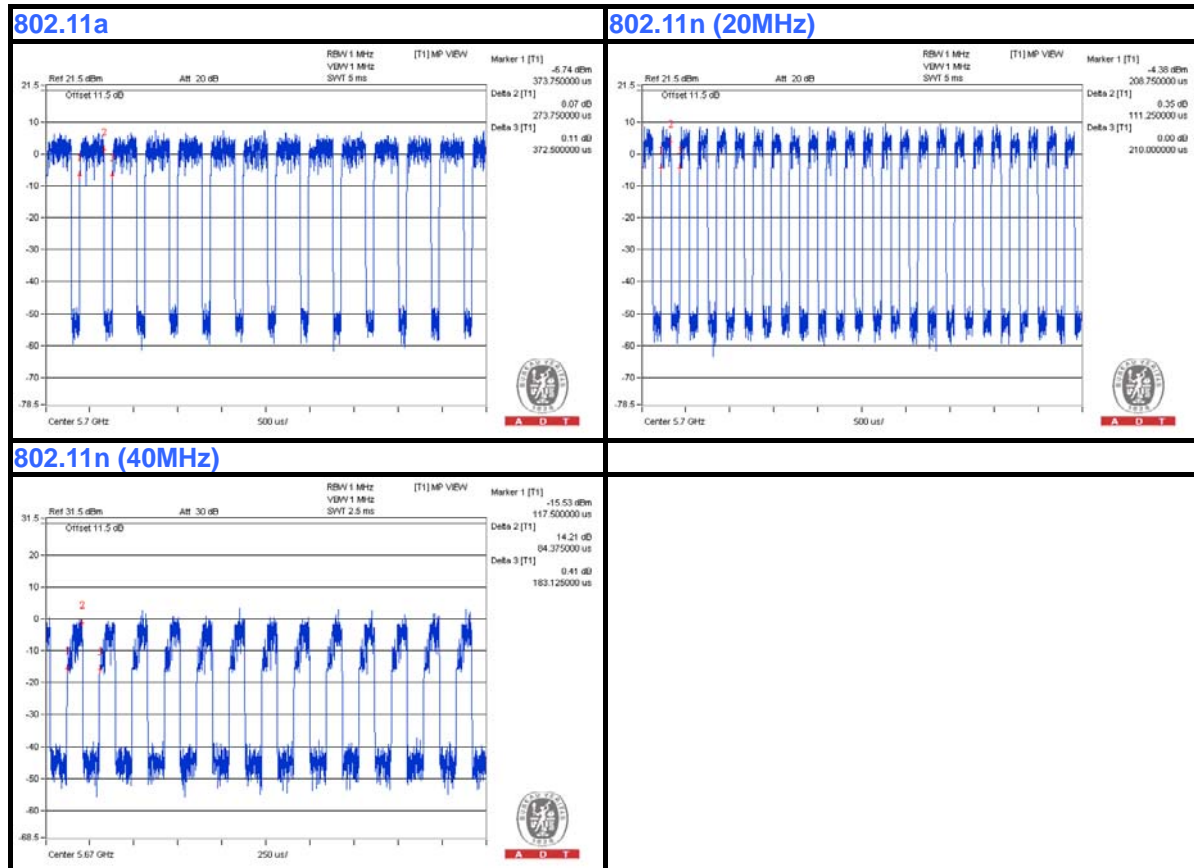

3.4 DESCRIPTION OF SUPPORT UNITS

The EUT has been tested as an independent unit.

3.4.1 CONFIGURATION OF SYSTEM UNDER TEST

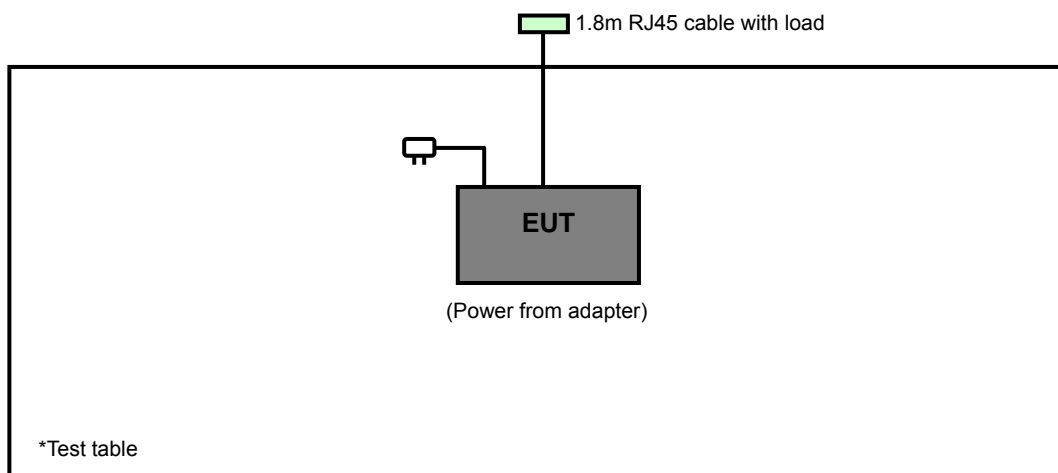

3.5 GENERAL DESCRIPTION OF APPLIED STANDARDS

The EUT is a RF Product. According to the specifications of the manufacturer, it must comply with the requirements of the following standards:

FCC Part 15, Subpart E (15.407)

789033 D01 General UNII Test Procedures v01 r03

ANSI C63.10-2009

All test items have been performed and recorded as per the above standards.

NOTE: The EUT is also considered as a kind of computer peripheral, because the connection to computer is necessary for typical use. It has been verified to comply with the requirements of FCC Part 15, Subpart B, Class B (DoC). The test report has been issued separately.

4. TEST TYPES AND RESULTS

4.1 RADIATED EMISSION AND BANDEDGE MEASUREMENT

4.1.1 LIMITS OF RADIATED EMISSION AND BANDEDGE MEASUREMENT

Radiated emissions which fall in the restricted bands must comply with the radiated emission limits specified as below table:

FREQUENCIES (MHz)	FIELD STRENGTH (microvolts/meter)	MEASUREMENT DISTANCE (meters)
0.009 ~ 0.490	2400/F(kHz)	300
0.490 ~ 1.705	24000/F(kHz)	30
1.705 ~ 30.0	30	30
30 ~ 88	100	3
88 ~ 216	150	3
216 ~ 960	200	3
Above 960	500	3

NOTE:

1. The lower limit shall apply at the transition frequencies.
2. Emission level (dBuV/m) = 20 log Emission level (uV/m).
3. For frequencies above 1000MHz, the field strength limits are based on average detector, however, the peak field strength of any emission shall not exceed the maximum permitted average limits, specified above by more than 20dB under any condition of modulation.

4.1.2 LIMITS OF UNWANTED EMISSION OUT OF THE RESTRICTED BANDS

APPLICABLE TO	LIMIT	
√	FIELD STRENGTH AT 3m (dBμV/m)	
	PK	AV
	74	54
	EIRP LIMIT (dBm)	EQUIVALENT FIELD STRENGTH AT 3m (dBμV/m)
	PK	PK
	-27	68.3

NOTE: The following formula is used to convert the equipment isotropic radiated power (eirp) to field strength:

$$E = \frac{1000000\sqrt{30P}}{3} \mu\text{V/m, where P is the eirp (Watts).}$$

4.1.3 TEST INSTRUMENTS

DESCRIPTION & MANUFACTURER	MODEL NO.	SERIAL NO.	DATE OF CALIBRATION	DUE DATE OF CALIBRATION
Test Receiver ROHDE & SCHWARZ	ESCI	100424	Sep. 09, 2013	Sep. 08, 2014
Spectrum Analyzer ROHDE & SCHWARZ	FSU 43	100115	Oct. 24, 2013	Oct. 23, 2014
BILOG Antenna SCHWARZBECK	VULB9168	9168-155	Mar. 25, 2013	Mar. 24, 2014
HORN Antenna SCHWARZBECK	BBHA 9120D	9120D-404	Dec. 22, 2012	Dec. 21, 2013
HORN Antenna SCHWARZBECK	BBHA 9170	148	Jul. 15, 2013	Jul. 14, 2014
Preamplifier Agilent	8449B	3008A01961	Oct. 28, 2013	Oct. 27, 2014
Preamplifier Agilent	8447D	2944A10738	Oct. 18, 2013	Oct. 17, 2014
RF signal cable HUBER+SUHNNER	SUCOFLEX 104	309220/4	Aug. 26, 2013	Aug. 25, 2014
RF signal cable HUBER+SUHNNER	SUCOFLEX 104	250724/4	Aug. 26, 2013	Aug. 25, 2014
RF signal cable HUBER+SUHNNER	SUCOFLEX 104	295012/4	Aug. 26, 2013	Aug. 25, 2014
Software BV ADT	ADT_Radiated_ V7.6.15.9.4	NA	NA	NA
Antenna Tower inn-co GmbH	MA 4000	010303	NA	NA
Antenna Tower Controller inn-co GmbH	CO2000	019303	NA	NA
Turn Table BV ADT	TT100.	TT93021704	NA	NA
Turn Table Controller BV ADT	SC100.	SC93021704	NA	NA
High Speed Peak Power Meter	ML2495A	0824011	Jul. 30, 2013	Jul. 29, 2014
Power Sensor	MA2411B	0738171	Jul. 30, 2013	Jul. 29, 2014
WIT Standard Temperature And Humidity Chamber	TH-4S-C	W981030	Jun. 13, 2013	Jun. 12, 2014

- NOTE:**
1. The calibration interval of the above test instruments is 12 months and the calibrations are traceable to NML/ROC and NIST/USA.
 2. The test was performed in HwaYa Chamber 4.
 3. The horn antenna and HP preamplifier (model: 8449B) are used only for the measurement of emission frequency above 1GHz if tested.
 4. The FCC Site Registration No. is 460141.
 5. The IC Site Registration No. is IC7450F-4.

4.1.4 TEST PROCEDURES

- a. The EUT was placed on the top of a rotating table 0.8 meters above the ground at a 3 meter semi-anechoic chamber. The table was rotated 360 degrees to determine the position of the highest radiation.
- b. The EUT was set 3 meters away from the interference-receiving antenna, which was mounted on the top of a variable-height antenna tower.
- c. The antenna is a broadband antenna, and its height is varied from one meter to four meters above the ground to determine the maximum value of the field strength. Both horizontal and vertical polarizations of the antenna are set to make the measurement.
- d. For each suspected emission, the EUT was arranged to its worst case and then the antenna was tuned to heights from 1 meter to 4 meters and the rotatable table was turned from 0 degrees to 360 degrees to find the maximum reading.
- e. The test-receiver system was set to Peak Detect Function and Specified Bandwidth with Maximum Hold Mode.
- f. If the emission level of the EUT in peak mode was 10dB lower than the limit specified, then testing could be stopped and the peak values of the EUT would be reported. Otherwise the emissions that did not have 10dB margin would be re-tested one by one using peak, quasi-peak or average method as specified and then reported in a data sheet.

NOTE:

1. The resolution bandwidth and video bandwidth of test receiver/spectrum analyzer is 120kHz for Quasi-peak detection at frequency below 1GHz.
2. The resolution bandwidth of test receiver/spectrum analyzer is 1MHz and video bandwidth is 3MHz for Peak detection at frequency above 1GHz.
3. The resolution bandwidth of test receiver/spectrum analyzer is 1MHz and the video bandwidth is $\geq 1/T$ (Duty cycle < 98%) or 10Hz(Duty cycle > 98%) for Average detection (AV) at frequency above 1GHz.
4. All modes of operation were investigated and the worst-case emissions are reported.

4.1.5 DEVIATION FROM TEST STANDARD

No deviation.

4.1.6 TEST SETUP

Frequency range 30MHz~1GHz

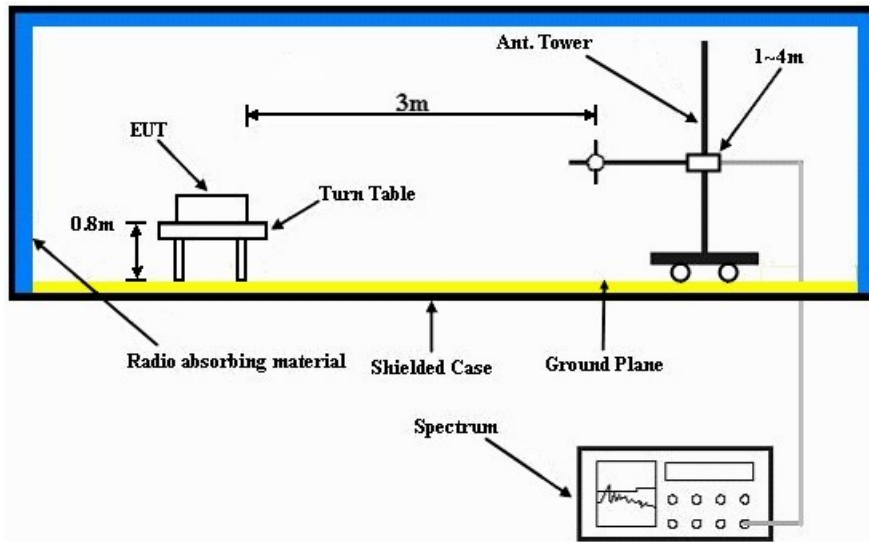

Frequency range above 1GHz

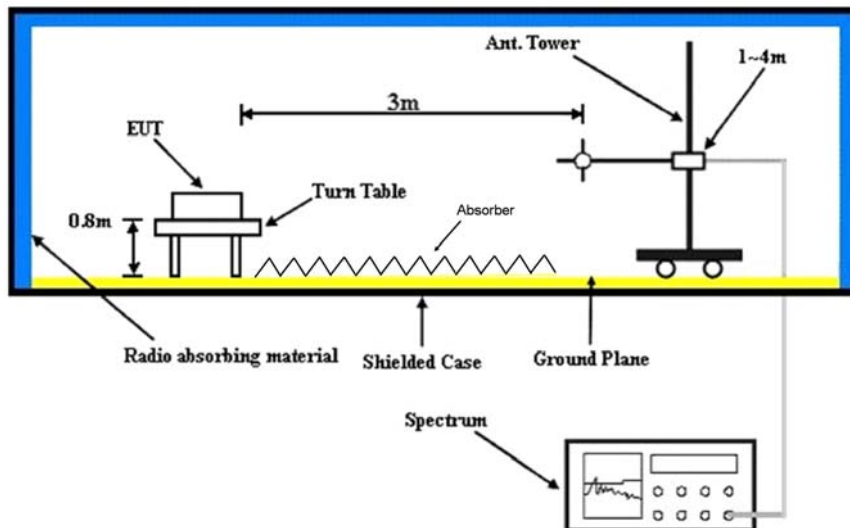

For the actual test configuration, please refer to the attached file (Test Setup Photo).

4.1.7 EUT OPERATING CONDITION

Set the EUT under transmission condition continuously at specific channel frequency.



4.1.8 TEST RESULTS

ABOVE 1GHz DATA :

802.11a

EUT TEST CONDITION		MEASUREMENT DETAIL	
CHANNEL	Channel 36	FREQUENCY RANGE	1 ~ 40GHz
INPUT POWER	120Vac, 60Hz	DETECTOR FUNCTION	Peak (PK) Average (AV)
ENVIRONMENTAL CONDITIONS	22deg. C, 69%RH	TESTED BY	Jones Chang

ANTENNA POLARITY & TEST DISTANCE: HORIZONTAL AT 3 M								
NO.	FREQ. (MHz)	EMISSION LEVEL (dBuV/m)	LIMIT (dBuV/m)	MARGIN (dB)	ANTENNA HEIGHT (m)	TABLE ANGLE (Degree)	RAW VALUE (dBuV)	CORRECTION FACTOR (dB/m)
1	5150.00	58.1 PK	74.0	-15.9	1.71 H	123	52.70	5.40
2	5150.00	45.5 AV	54.0	-8.5	1.71 H	123	40.10	5.40
3	*5180.00	105.2 PK			1.68 H	86	65.90	39.30
4	*5180.00	94.7 AV			1.68 H	86	55.40	39.30
5	#10360.00	58.5 PK	74.0	-15.5	1.50 H	55	42.50	16.00
6	#10360.00	47.2 AV	54.0	-6.8	1.50 H	55	31.20	16.00
ANTENNA POLARITY & TEST DISTANCE: VERTICAL AT 3 M								
NO.	FREQ. (MHz)	EMISSION LEVEL (dBuV/m)	LIMIT (dBuV/m)	MARGIN (dB)	ANTENNA HEIGHT (m)	TABLE ANGLE (Degree)	RAW VALUE (dBuV)	CORRECTION FACTOR (dB/m)
1	5150.00	55.5 PK	74.0	-18.5	1.30 V	90	50.10	5.40
2	5150.00	44.4 AV	54.0	-9.6	1.30 V	90	39.00	5.40
3	*5180.00	99.4 PK			1.29 V	79	60.10	39.30
4	*5180.00	89.8 AV			1.29 V	79	50.50	39.30
5	#10360.00	57.5 PK	74.0	-16.5	1.00 V	111	41.50	16.00
6	#10360.00	45.8 AV	54.0	-8.2	1.00 V	111	29.80	16.00

REMARKS:

1. Emission Level(dBuV/m) = Raw Value(dBuV) + Correction Factor(dB/m)
2. Correction Factor(dB/m) = Antenna Factor(dB/m) + Cable Factor(dB) – Pre-Amplifier Factor(dB)
3. The other emission levels were very low against the limit.
4. Margin value = Emission Level – Limit value
5. “ * “: Fundamental frequency.
6. “#”:The radiated frequency is out the restricted band.



A D T

EUT TEST CONDITION		MEASUREMENT DETAIL	
CHANNEL	Channel 40	FREQUENCY RANGE	1 ~ 40GHz
INPUT POWER	120Vac, 60Hz	DETECTOR FUNCTION	Peak (PK) Average (AV)
ENVIRONMENTAL CONDITIONS	22deg. C, 69%RH	TESTED BY	Jones Chang

ANTENNA POLARITY & TEST DISTANCE: HORIZONTAL AT 3 M								
NO.	FREQ. (MHz)	EMISSION LEVEL (dBuV/m)	LIMIT (dBuV/m)	MARGIN (dB)	ANTENNA HEIGHT (m)	TABLE ANGLE (Degree)	RAW VALUE (dBuV)	CORRECTION FACTOR (dB/m)
1	*5200.00	103.9 PK			1.65 H	118	64.60	39.30
2	*5200.00	93.7 AV			1.65 H	118	54.40	39.30
3	#10400.00	58.1 PK	74.0	-15.9	1.19 H	239	41.90	16.20
4	#10400.00	46.0 AV	54.0	-8.0	1.19 H	239	29.80	16.20
ANTENNA POLARITY & TEST DISTANCE: VERTICAL AT 3 M								
NO.	FREQ. (MHz)	EMISSION LEVEL (dBuV/m)	LIMIT (dBuV/m)	MARGIN (dB)	ANTENNA HEIGHT (m)	TABLE ANGLE (Degree)	RAW VALUE (dBuV)	CORRECTION FACTOR (dB/m)
1	*5200.00	99.7 PK			1.29 V	81	60.40	39.30
2	*5200.00	89.7 AV			1.29 V	81	50.40	39.30
3	#10400.00	57.0 PK	74.0	-17.0	1.00 V	309	40.80	16.20
4	#10400.00	45.4 AV	54.0	-8.6	1.00 V	309	29.20	16.20

REMARKS:

1. Emission Level(dBuV/m) = Raw Value(dBuV) + Correction Factor(dB/m)
2. Correction Factor(dB/m) = Antenna Factor(dB/m) + Cable Factor(dB) – Pre-Amplifier Factor(dB)
3. The other emission levels were very low against the limit.
4. Margin value = Emission Level – Limit value
5. “ * “: Fundamental frequency.
6. “#“:The radiated frequency is out the restricted band.



EUT TEST CONDITION		MEASUREMENT DETAIL	
CHANNEL	Channel 48	FREQUENCY RANGE	1 ~ 40GHz
INPUT POWER	120Vac, 60Hz	DETECTOR FUNCTION	Peak (PK) Average (AV)
ENVIRONMENTAL CONDITIONS	22deg. C, 69%RH	TESTED BY	Jones Chang

ANTENNA POLARITY & TEST DISTANCE: HORIZONTAL AT 3 M								
NO.	FREQ. (MHz)	EMISSION LEVEL (dBuV/m)	LIMIT (dBuV/m)	MARGIN (dB)	ANTENNA HEIGHT (m)	TABLE ANGLE (Degree)	RAW VALUE (dBuV)	CORRECTION FACTOR (dB/m)
1	*5240.00	104.3 PK			1.64 H	103	65.00	39.30
2	*5240.00	94.2 AV			1.64 H	103	54.90	39.30
3	5350.00	56.4 PK	74.0	-17.6	1.66 H	99	50.90	5.50
4	5350.00	44.9 AV	54.0	-9.1	1.66 H	99	39.40	5.50
5	#10480.00	58.3 PK	74.0	-15.7	1.33 H	53	41.50	16.80
6	#10480.00	46.5 AV	54.0	-7.5	1.33 H	53	29.70	16.80
ANTENNA POLARITY & TEST DISTANCE: VERTICAL AT 3 M								
NO.	FREQ. (MHz)	EMISSION LEVEL (dBuV/m)	LIMIT (dBuV/m)	MARGIN (dB)	ANTENNA HEIGHT (m)	TABLE ANGLE (Degree)	RAW VALUE (dBuV)	CORRECTION FACTOR (dB/m)
1	*5240.00	99.0 PK			1.41 V	81	59.70	39.30
2	*5240.00	89.2 AV			1.41 V	81	49.90	39.30
3	5350.00	56.6 PK	74.0	-17.4	1.41 V	100	51.10	5.50
4	5350.00	45.3 AV	54.0	-8.7	1.41 V	100	39.80	5.50
5	#10480.00	57.1 PK	74.0	-16.9	1.00 V	300	40.30	16.80
6	#10480.00	45.7 AV	54.0	-8.3	1.00 V	300	28.90	16.80

REMARKS:

1. Emission Level(dBuV/m) = Raw Value(dBuV) + Correction Factor(dB/m)
2. Correction Factor(dB/m) = Antenna Factor(dB/m) + Cable Factor(dB)
– Pre-Amplifier Factor(dB)
3. The other emission levels were very low against the limit.
4. Margin value = Emission Level – Limit value
5. “ * “: Fundamental frequency.
6. “#”:The radiated frequency is out the restricted band.

EUT TEST CONDITION		MEASUREMENT DETAIL	
CHANNEL	Channel 52	FREQUENCY RANGE	1 ~ 40GHz
INPUT POWER	120Vac, 60Hz	DETECTOR FUNCTION	Peak (PK) Average (AV)
ENVIRONMENTAL CONDITIONS	22deg. C, 69%RH	TESTED BY	Jones Chang

ANTENNA POLARITY & TEST DISTANCE: HORIZONTAL AT 3 M								
NO.	FREQ. (MHz)	EMISSION LEVEL (dBuV/m)	LIMIT (dBuV/m)	MARGIN (dB)	ANTENNA HEIGHT (m)	TABLE ANGLE (Degree)	RAW VALUE (dBuV)	CORRECTION FACTOR (dB/m)
1	5150.00	55.4 PK	74.0	-18.6	1.60 H	133	50.00	5.40
2	5150.00	44.5 AV	54.0	-9.5	1.60 H	133	39.10	5.40
3	*5260.00	104.3 PK			1.60 H	133	65.00	39.30
4	*5260.00	94.1 AV			1.60 H	133	54.80	39.30
5	#10520.00	59.1 PK	74.0	-14.9	1.33 H	247	42.30	16.80
6	#10520.00	46.2 AV	54.0	-7.8	1.33 H	247	29.40	16.80
ANTENNA POLARITY & TEST DISTANCE: VERTICAL AT 3 M								
NO.	FREQ. (MHz)	EMISSION LEVEL (dBuV/m)	LIMIT (dBuV/m)	MARGIN (dB)	ANTENNA HEIGHT (m)	TABLE ANGLE (Degree)	RAW VALUE (dBuV)	CORRECTION FACTOR (dB/m)
1	5150.00	55.1 PK	74.0	-18.9	1.59 V	11	49.70	5.40
2	5150.00	43.9 AV	54.0	-10.1	1.59 V	11	38.50	5.40
3	*5260.00	98.8 PK			1.60 V	359	59.50	39.30
4	*5260.00	89.6 AV			1.60 V	359	50.30	39.30
5	#10520.00	58.3 PK	74.0	-15.7	1.00 V	207	41.50	16.80
6	#10520.00	45.6 AV	54.0	-8.4	1.00 V	207	28.80	16.80

REMARKS:

1. Emission Level(dBuV/m) = Raw Value(dBuV) + Correction Factor(dB/m)
2. Correction Factor(dB/m) = Antenna Factor(dB/m) + Cable Factor(dB)
– Pre-Amplifier Factor(dB)
3. The other emission levels were very low against the limit.
4. Margin value = Emission Level – Limit value
5. " * ": Fundamental frequency.
6. "#":The radiated frequency is out the restricted band.



A D T

EUT TEST CONDITION		MEASUREMENT DETAIL	
CHANNEL	Channel 60	FREQUENCY RANGE	1 ~ 40GHz
INPUT POWER	120Vac, 60Hz	DETECTOR FUNCTION	Peak (PK) Average (AV)
ENVIRONMENTAL CONDITIONS	22deg. C, 69%RH	TESTED BY	Jones Chang

ANTENNA POLARITY & TEST DISTANCE: HORIZONTAL AT 3 M								
NO.	FREQ. (MHz)	EMISSION LEVEL (dBuV/m)	LIMIT (dBuV/m)	MARGIN (dB)	ANTENNA HEIGHT (m)	TABLE ANGLE (Degree)	RAW VALUE (dBuV)	CORRECTION FACTOR (dB/m)
1	*5320.00	104.3 PK			1.60 H	129	64.90	39.40
2	*5320.00	94.1 AV			1.60 H	129	54.70	39.40
3	10600.00	59.3 PK	74.0	-14.7	1.26 H	85	42.80	16.50
4	10600.00	46.2 AV	54.0	-7.8	1.26 H	85	29.70	16.50
ANTENNA POLARITY & TEST DISTANCE: VERTICAL AT 3 M								
NO.	FREQ. (MHz)	EMISSION LEVEL (dBuV/m)	LIMIT (dBuV/m)	MARGIN (dB)	ANTENNA HEIGHT (m)	TABLE ANGLE (Degree)	RAW VALUE (dBuV)	CORRECTION FACTOR (dB/m)
1	*5320.00	99.4 PK			1.59 V	1	60.00	39.40
2	*5320.00	89.5 AV			1.59 V	1	50.10	39.40
3	10600.00	58.2 PK	74.0	-15.8	1.00 V	13	41.70	16.50
4	10600.00	45.3 AV	54.0	-8.7	1.00 V	13	28.80	16.50

REMARKS:

1. Emission Level(dBuV/m) = Raw Value(dBuV) + Correction Factor(dB/m)
2. Correction Factor(dB/m) = Antenna Factor(dB/m) + Cable Factor(dB) – Pre-Amplifier Factor(dB)
3. The other emission levels were very low against the limit.
4. Margin value = Emission Level – Limit value
5. “ * “: Fundamental frequency.



EUT TEST CONDITION		MEASUREMENT DETAIL	
CHANNEL	Channel 64	FREQUENCY RANGE	1 ~ 40GHz
INPUT POWER	120Vac, 60Hz	DETECTOR FUNCTION	Peak (PK) Average (AV)
ENVIRONMENTAL CONDITIONS	22deg. C, 69%RH	TESTED BY	Jones Chang

ANTENNA POLARITY & TEST DISTANCE: HORIZONTAL AT 3 M								
NO.	FREQ. (MHz)	EMISSION LEVEL (dBuV/m)	LIMIT (dBuV/m)	MARGIN (dB)	ANTENNA HEIGHT (m)	TABLE ANGLE (Degree)	RAW VALUE (dBuV)	CORRECTION FACTOR (dB/m)
1	*5320.00	103.9 PK			1.59 H	12	64.50	39.40
2	*5320.00	93.6 AV			1.59 H	12	54.20	39.40
3	5350.00	55.7 PK	74.0	-18.3	1.63 H	155	50.20	5.50
4	5350.00	45.1 AV	54.0	-8.9	1.63 H	155	39.60	5.50
5	10640.00	59.1 PK	74.0	-14.9	1.55 H	222	42.30	16.80
6	10640.00	46.7 AV	54.0	-7.3	1.55 H	222	29.90	16.80
ANTENNA POLARITY & TEST DISTANCE: VERTICAL AT 3 M								
NO.	FREQ. (MHz)	EMISSION LEVEL (dBuV/m)	LIMIT (dBuV/m)	MARGIN (dB)	ANTENNA HEIGHT (m)	TABLE ANGLE (Degree)	RAW VALUE (dBuV)	CORRECTION FACTOR (dB/m)
1	*5320.00	99.2 PK			1.59 V	129	59.80	39.40
2	*5320.00	89.6 AV			1.59 V	129	50.20	39.40
3	5350.00	55.3 PK	74.0	-18.7	1.60 V	135	49.80	5.50
4	5350.00	44.5 AV	54.0	-9.5	1.60 V	135	39.00	5.50
5	10640.00	58.2 PK	74.0	-15.8	1.00 V	101	41.40	16.80
6	10640.00	45.7 AV	54.0	-8.3	1.00 V	101	28.90	16.80

REMARKS:

1. Emission Level(dBuV/m) = Raw Value(dBuV) + Correction Factor(dB/m)
2. Correction Factor(dB/m) = Antenna Factor(dB/m) + Cable Factor(dB)
– Pre-Amplifier Factor(dB)
3. The other emission levels were very low against the limit.
4. Margin value = Emission Level – Limit value
5. “ * “: Fundamental frequency.

EUT TEST CONDITION		MEASUREMENT DETAIL	
CHANNEL	Channel 100	FREQUENCY RANGE	1 ~ 40GHz
INPUT POWER	120Vac, 60Hz	DETECTOR FUNCTION	Peak (PK) Average (AV)
ENVIRONMENTAL CONDITIONS	22deg. C, 69%RH	TESTED BY	Jones Chang

ANTENNA POLARITY & TEST DISTANCE: HORIZONTAL AT 3 M								
NO.	FREQ. (MHz)	EMISSION LEVEL (dBuV/m)	LIMIT (dBuV/m)	MARGIN (dB)	ANTENNA HEIGHT (m)	TABLE ANGLE (Degree)	RAW VALUE (dBuV)	CORRECTION FACTOR (dB/m)
1	5460.00	58.4 PK	74.0	-15.6	1.31 H	122	52.80	5.60
2	5460.00	45.7 AV	54.0	-8.3	1.31 H	122	40.10	5.60
3	#5470.00	57.0 PK	74.0	-17.0	1.30 H	125	51.40	5.60
4	#5470.00	45.0 AV	54.0	-9.0	1.30 H	125	39.40	5.60
5	*5500.00	104.1 PK			1.29 H	123	64.50	39.60
6	*5500.00	94.2 AV			1.29 H	123	54.60	39.60
7	11000.00	61.4 PK	74.0	-12.6	1.08 H	59	42.90	18.50
8	11000.00	49.7 AV	54.0	-4.3	1.08 H	59	31.20	18.50

ANTENNA POLARITY & TEST DISTANCE: VERTICAL AT 3 M								
NO.	FREQ. (MHz)	EMISSION LEVEL (dBuV/m)	LIMIT (dBuV/m)	MARGIN (dB)	ANTENNA HEIGHT (m)	TABLE ANGLE (Degree)	RAW VALUE (dBuV)	CORRECTION FACTOR (dB/m)
1	5460.00	56.7 PK	74.0	-17.3	1.45 V	83	51.10	5.60
2	5460.00	45.8 AV	54.0	-8.2	1.45 V	83	40.20	5.60
3	#5470.00	58.3 PK	74.0	-15.7	1.46 V	79	52.70	5.60
4	#5470.00	47.3 AV	54.0	-6.7	1.46 V	79	41.70	5.60
5	*5500.00	100.2 PK			1.46 V	79	60.60	39.60
6	*5500.00	90.4 AV			1.46 V	79	50.80	39.60
7	11000.00	60.0 PK	74.0	-14.0	1.01 V	233	41.50	18.50
8	11000.00	48.2 AV	54.0	-5.8	1.01 V	233	29.70	18.50

REMARKS:

1. Emission Level(dBuV/m) = Raw Value(dBuV) + Correction Factor(dB/m)
2. Correction Factor(dB/m) = Antenna Factor(dB/m) + Cable Factor(dB)
– Pre-Amplifier Factor(dB)
3. The other emission levels were very low against the limit.
4. Margin value = Emission Level – Limit value
5. " * ": Fundamental frequency.
6. "#":The radiated frequency is out the restricted band.



EUT TEST CONDITION		MEASUREMENT DETAIL	
CHANNEL	Channel 116	FREQUENCY RANGE	1 ~ 40GHz
INPUT POWER	120Vac, 60Hz	DETECTOR FUNCTION	Peak (PK) Average (AV)
ENVIRONMENTAL CONDITIONS	22deg. C, 69%RH	TESTED BY	Jones Chang

ANTENNA POLARITY & TEST DISTANCE: HORIZONTAL AT 3 M								
NO.	FREQ. (MHz)	EMISSION LEVEL (dBuV/m)	LIMIT (dBuV/m)	MARGIN (dB)	ANTENNA HEIGHT (m)	TABLE ANGLE (Degree)	RAW VALUE (dBuV)	CORRECTION FACTOR (dB/m)
1	*5580.00	103.4 PK			1.26 H	61	63.60	39.80
2	*5580.00	93.3 AV			1.26 H	61	53.50	39.80
3	11160.00	59.8 PK	74.0	-14.2	1.26 H	60	41.40	18.40
4	11160.00	48.0 AV	54.0	-6.0	1.26 H	60	29.60	18.40
ANTENNA POLARITY & TEST DISTANCE: VERTICAL AT 3 M								
NO.	FREQ. (MHz)	EMISSION LEVEL (dBuV/m)	LIMIT (dBuV/m)	MARGIN (dB)	ANTENNA HEIGHT (m)	TABLE ANGLE (Degree)	RAW VALUE (dBuV)	CORRECTION FACTOR (dB/m)
1	*5580.00	99.9 PK			1.43 V	80	60.10	39.80
2	*5580.00	89.7 AV			1.43 V	80	49.90	39.80
3	11160.00	58.6 PK	74.0	-15.4	1.06 V	110	40.20	18.40
4	11160.00	47.4 AV	54.0	-6.6	1.06 V	110	29.00	18.40

REMARKS:

1. Emission Level(dBuV/m) = Raw Value(dBuV) + Correction Factor(dB/m)
2. Correction Factor(dB/m) = Antenna Factor(dB/m) + Cable Factor(dB) – Pre-Amplifier Factor(dB)
3. The other emission levels were very low against the limit.
4. Margin value = Emission Level – Limit value
5. “ * “: Fundamental frequency.



A D T

EUT TEST CONDITION		MEASUREMENT DETAIL	
CHANNEL	Channel 140	FREQUENCY RANGE	1 ~ 40GHz
INPUT POWER	120Vac, 60Hz	DETECTOR FUNCTION	Peak (PK) Average (AV)
ENVIRONMENTAL CONDITIONS	22deg. C, 69%RH	TESTED BY	Jones Chang

ANTENNA POLARITY & TEST DISTANCE: HORIZONTAL AT 3 M								
NO.	FREQ. (MHz)	EMISSION LEVEL (dBuV/m)	LIMIT (dBuV/m)	MARGIN (dB)	ANTENNA HEIGHT (m)	TABLE ANGLE (Degree)	RAW VALUE (dBuV)	CORRECTION FACTOR (dB/m)
1	*5700.00	104.2 PK			1.77 H	118	64.10	40.10
2	*5700.00	93.3 AV			1.77 H	118	53.20	40.10
3	#5725.00	59.6 PK	74.0	-14.4	1.77 H	120	53.30	6.30
4	#5725.00	47.7 AV	54.0	-6.3	1.77 H	120	41.40	6.30
5	11400.00	59.3 PK	74.0	-14.7	1.65 H	359	41.10	18.20
6	11400.00	47.4 AV	54.0	-6.6	1.65 H	359	29.20	18.20
ANTENNA POLARITY & TEST DISTANCE: VERTICAL AT 3 M								
NO.	FREQ. (MHz)	EMISSION LEVEL (dBuV/m)	LIMIT (dBuV/m)	MARGIN (dB)	ANTENNA HEIGHT (m)	TABLE ANGLE (Degree)	RAW VALUE (dBuV)	CORRECTION FACTOR (dB/m)
1	*5700.00	100.5 PK			1.44 V	80	60.40	40.10
2	*5700.00	90.4 AV			1.44 V	80	50.30	40.10
3	#5725.00	56.4 PK	74.0	-17.6	1.40 V	90	50.10	6.30
4	#5725.00	46.6 AV	54.0	-7.4	1.40 V	90	40.30	6.30
5	11400.00	58.2 PK	74.0	-15.8	1.05 V	69	40.00	18.20
6	11400.00	47.0 AV	54.0	-7.0	1.05 V	69	28.80	18.20

REMARKS:

1. Emission Level(dBuV/m) = Raw Value(dBuV) + Correction Factor(dB/m)
2. Correction Factor(dB/m) = Antenna Factor(dB/m) + Cable Factor(dB) – Pre-Amplifier Factor(dB)
3. The other emission levels were very low against the limit.
4. Margin value = Emission Level – Limit value
5. “ * “: Fundamental frequency.
6. “#”:The radiated frequency is out the restricted band.

802.11n (20MHz)

EUT TEST CONDITION		MEASUREMENT DETAIL	
CHANNEL	Channel 36	FREQUENCY RANGE	1 ~ 40GHz
INPUT POWER	120Vac, 60Hz	DETECTOR FUNCTION	Peak (PK) Average (AV)
ENVIRONMENTAL CONDITIONS	22deg. C, 69%RH	TESTED BY	Jones Chang

ANTENNA POLARITY & TEST DISTANCE: HORIZONTAL AT 3 M								
NO.	FREQ. (MHz)	EMISSION LEVEL (dBuV/m)	LIMIT (dBuV/m)	MARGIN (dB)	ANTENNA HEIGHT (m)	TABLE ANGLE (Degree)	RAW VALUE (dBuV)	CORRECTION FACTOR (dB/m)
1	5150.00	59.4 PK	74.0	-14.6	1.27 H	82	54.00	5.40
2	5150.00	45.5 AV	54.0	-8.5	1.27 H	82	40.10	5.40
3	*5180.00	105.8 PK			1.27 H	82	66.50	39.30
4	*5180.00	95.0 AV			1.27 H	82	55.70	39.30
5	#10360.00	58.1 PK	74.0	-15.9	1.42 H	158	42.10	16.00
6	#10360.00	47.0 AV	54.0	-7.0	1.42 H	158	31.00	16.00

ANTENNA POLARITY & TEST DISTANCE: VERTICAL AT 3 M								
NO.	FREQ. (MHz)	EMISSION LEVEL (dBuV/m)	LIMIT (dBuV/m)	MARGIN (dB)	ANTENNA HEIGHT (m)	TABLE ANGLE (Degree)	RAW VALUE (dBuV)	CORRECTION FACTOR (dB/m)
1	5150.00	58.4 PK	74.0	-15.6	2.34 V	177	53.00	5.40
2	5150.00	44.4 AV	54.0	-9.6	2.43 V	177	39.00	5.40
3	*5180.00	99.8 PK			2.34 V	177	60.50	39.30
4	*5180.00	88.8 AV			2.34 V	177	49.50	39.30
5	#10360.00	58.0 PK	74.0	-16.0	1.05 V	128	42.00	16.00
6	#10360.00	46.8 AV	54.0	-7.2	1.05 V	128	30.80	16.00

REMARKS:

1. Emission Level(dBuV/m) = Raw Value(dBuV) + Correction Factor(dB/m)
2. Correction Factor(dB/m) = Antenna Factor(dB/m) + Cable Factor(dB)
– Pre-Amplifier Factor(dB)
3. The other emission levels were very low against the limit.
4. Margin value = Emission Level – Limit value
5. “ * “: Fundamental frequency.
6. “#”:The radiated frequency is out the restricted band.



EUT TEST CONDITION		MEASUREMENT DETAIL	
CHANNEL	Channel 40	FREQUENCY RANGE	1 ~ 40GHz
INPUT POWER	120Vac, 60Hz	DETECTOR FUNCTION	Peak (PK) Average (AV)
ENVIRONMENTAL CONDITIONS	22deg. C, 69%RH	TESTED BY	Jones Chang

ANTENNA POLARITY & TEST DISTANCE: HORIZONTAL AT 3 M								
NO.	FREQ. (MHz)	EMISSION LEVEL (dBuV/m)	LIMIT (dBuV/m)	MARGIN (dB)	ANTENNA HEIGHT (m)	TABLE ANGLE (Degree)	RAW VALUE (dBuV)	CORRECTION FACTOR (dB/m)
1	*5200.00	105.3 PK			1.25 H	90	66.00	39.30
2	*5200.00	94.4 AV			1.25 H	90	55.10	39.30
3	#10400.00	58.2 PK	74.0	-15.8	1.35 H	125	42.00	16.20
4	#10400.00	47.1 AV	54.0	-6.9	1.35 H	125	30.90	16.20
ANTENNA POLARITY & TEST DISTANCE: VERTICAL AT 3 M								
NO.	FREQ. (MHz)	EMISSION LEVEL (dBuV/m)	LIMIT (dBuV/m)	MARGIN (dB)	ANTENNA HEIGHT (m)	TABLE ANGLE (Degree)	RAW VALUE (dBuV)	CORRECTION FACTOR (dB/m)
1	*5200.00	100.3 PK			2.30 V	163	61.00	39.30
2	*5200.00	89.4 AV			2.30 V	163	50.10	39.30
3	#10400.00	58.1 PK	74.0	-15.9	1.25 V	160	41.90	16.20
4	#10400.00	46.9 AV	54.0	-7.1	1.25 V	160	30.70	16.20

REMARKS:

1. Emission Level(dBuV/m) = Raw Value(dBuV) + Correction Factor(dB/m)
2. Correction Factor(dB/m) = Antenna Factor(dB/m) + Cable Factor(dB)
– Pre-Amplifier Factor(dB)
3. The other emission levels were very low against the limit.
4. Margin value = Emission Level – Limit value
5. “ * “: Fundamental frequency.
6. “#”:The radiated frequency is out the restricted band.



A D T

EUT TEST CONDITION		MEASUREMENT DETAIL	
CHANNEL	Channel 48	FREQUENCY RANGE	1 ~ 40GHz
INPUT POWER	120Vac, 60Hz	DETECTOR FUNCTION	Peak (PK) Average (AV)
ENVIRONMENTAL CONDITIONS	22deg. C, 69%RH	TESTED BY	Jones Chang

ANTENNA POLARITY & TEST DISTANCE: HORIZONTAL AT 3 M								
NO.	FREQ. (MHz)	EMISSION LEVEL (dBuV/m)	LIMIT (dBuV/m)	MARGIN (dB)	ANTENNA HEIGHT (m)	TABLE ANGLE (Degree)	RAW VALUE (dBuV)	CORRECTION FACTOR (dB/m)
1	*5240.00	105.2 PK			1.22 H	81	65.90	39.30
2	*5240.00	94.5 AV			1.22 H	81	55.20	39.30
3	#10480.00	58.9 PK	74.0	-15.1	1.27 H	163	42.10	16.80
4	#10480.00	47.7 AV	54.0	-6.3	1.27 H	163	30.90	16.80
ANTENNA POLARITY & TEST DISTANCE: VERTICAL AT 3 M								
NO.	FREQ. (MHz)	EMISSION LEVEL (dBuV/m)	LIMIT (dBuV/m)	MARGIN (dB)	ANTENNA HEIGHT (m)	TABLE ANGLE (Degree)	RAW VALUE (dBuV)	CORRECTION FACTOR (dB/m)
1	*5240.00	100.2 PK			2.40 V	180	60.90	39.30
2	*5240.00	89.5 AV			2.40 V	180	50.20	39.30
3	#10480.00	58.8 PK	74.0	-15.2	1.08 V	100	42.00	16.80
4	#10480.00	47.6 AV	54.0	-6.4	1.08 V	100	30.80	16.80

REMARKS:

1. Emission Level(dBuV/m) = Raw Value(dBuV) + Correction Factor(dB/m)
2. Correction Factor(dB/m) = Antenna Factor(dB/m) + Cable Factor(dB)
– Pre-Amplifier Factor(dB)
3. The other emission levels were very low against the limit.
4. Margin value = Emission Level – Limit value
5. “ * “: Fundamental frequency.
6. “#”:The radiated frequency is out the restricted band.



A D T

EUT TEST CONDITION		MEASUREMENT DETAIL	
CHANNEL	Channel 52	FREQUENCY RANGE	1 ~ 40GHz
INPUT POWER	120Vac, 60Hz	DETECTOR FUNCTION	Peak (PK) Average (AV)
ENVIRONMENTAL CONDITIONS	22deg. C, 69%RH	TESTED BY	Jones Chang

ANTENNA POLARITY & TEST DISTANCE: HORIZONTAL AT 3 M								
NO.	FREQ. (MHz)	EMISSION LEVEL (dBuV/m)	LIMIT (dBuV/m)	MARGIN (dB)	ANTENNA HEIGHT (m)	TABLE ANGLE (Degree)	RAW VALUE (dBuV)	CORRECTION FACTOR (dB/m)
1	*5260.00	105.1 PK			1.23 H	86	65.80	39.30
2	*5260.00	94.5 AV			1.23 H	86	55.20	39.30
3	#10520.00	58.8 PK	74.0	-15.2	1.28 H	155	42.00	16.80
4	#10520.00	47.5 AV	54.0	-6.5	1.28 H	155	30.70	16.80
ANTENNA POLARITY & TEST DISTANCE: VERTICAL AT 3 M								
NO.	FREQ. (MHz)	EMISSION LEVEL (dBuV/m)	LIMIT (dBuV/m)	MARGIN (dB)	ANTENNA HEIGHT (m)	TABLE ANGLE (Degree)	RAW VALUE (dBuV)	CORRECTION FACTOR (dB/m)
1	*5260.00	100.1 PK			2.51 V	196	60.80	39.30
2	*5260.00	89.3 AV			2.51 V	196	50.00	39.30
3	#10520.00	58.7 PK	74.0	-15.3	1.11 V	133	41.90	16.80
4	#10520.00	47.4 AV	54.0	-6.6	1.11 V	133	30.60	16.80

REMARKS:

1. Emission Level(dBuV/m) = Raw Value(dBuV) + Correction Factor(dB/m)
2. Correction Factor(dB/m) = Antenna Factor(dB/m) + Cable Factor(dB)
– Pre-Amplifier Factor(dB)
3. The other emission levels were very low against the limit.
4. Margin value = Emission Level – Limit value
5. “ * “: Fundamental frequency.
6. “#”:The radiated frequency is out the restricted band.



A D T

EUT TEST CONDITION		MEASUREMENT DETAIL	
CHANNEL	Channel 60	FREQUENCY RANGE	1 ~ 40GHz
INPUT POWER	120Vac, 60Hz	DETECTOR FUNCTION	Peak (PK) Average (AV)
ENVIRONMENTAL CONDITIONS	22deg. C, 69%RH	TESTED BY	Jones Chang

ANTENNA POLARITY & TEST DISTANCE: HORIZONTAL AT 3 M								
NO.	FREQ. (MHz)	EMISSION LEVEL (dBuV/m)	LIMIT (dBuV/m)	MARGIN (dB)	ANTENNA HEIGHT (m)	TABLE ANGLE (Degree)	RAW VALUE (dBuV)	CORRECTION FACTOR (dB/m)
1	*5300.00	105.1 PK			1.22 H	75	65.70	39.40
2	*5300.00	94.4 AV			1.22 H	75	55.00	39.40
3	10600.00	58.4 PK	74.0	-15.6	1.08 H	169	41.90	16.50
4	10600.00	47.0 AV	54.0	-7.0	1.08 H	169	30.50	16.50
ANTENNA POLARITY & TEST DISTANCE: VERTICAL AT 3 M								
NO.	FREQ. (MHz)	EMISSION LEVEL (dBuV/m)	LIMIT (dBuV/m)	MARGIN (dB)	ANTENNA HEIGHT (m)	TABLE ANGLE (Degree)	RAW VALUE (dBuV)	CORRECTION FACTOR (dB/m)
1	*5300.00	99.9 PK			2.23 V	185	60.50	39.40
2	*5300.00	89.4 AV			2.23 V	185	50.00	39.40
3	10600.00	58.2 PK	74.0	-15.8	1.12 V	136	41.70	16.50
4	10600.00	46.8 AV	54.0	-7.2	1.12 V	136	30.30	16.50

REMARKS:

1. Emission Level(dBuV/m) = Raw Value(dBuV) + Correction Factor(dB/m)
2. Correction Factor(dB/m) = Antenna Factor(dB/m) + Cable Factor(dB)
– Pre-Amplifier Factor(dB)
3. The other emission levels were very low against the limit.
4. Margin value = Emission Level – Limit value
5. “ * “: Fundamental frequency.



EUT TEST CONDITION		MEASUREMENT DETAIL	
CHANNEL	Channel 64	FREQUENCY RANGE	1 ~ 40GHz
INPUT POWER	120Vac, 60Hz	DETECTOR FUNCTION	Peak (PK) Average (AV)
ENVIRONMENTAL CONDITIONS	22deg. C, 69%RH	TESTED BY	Jones Chang

ANTENNA POLARITY & TEST DISTANCE: HORIZONTAL AT 3 M								
NO.	FREQ. (MHz)	EMISSION LEVEL (dBuV/m)	LIMIT (dBuV/m)	MARGIN (dB)	ANTENNA HEIGHT (m)	TABLE ANGLE (Degree)	RAW VALUE (dBuV)	CORRECTION FACTOR (dB/m)
1	*5320.00	104.6 PK			1.27 H	100	65.20	39.40
2	*5320.00	94.3 AV			1.27 H	100	54.90	39.40
3	5350.00	57.1 PK	74.0	-16.9	1.27 H	100	51.60	5.50
4	5350.00	46.3 AV	54.0	-7.7	1.27 H	100	40.80	5.50
5	10640.00	58.5 PK	74.0	-15.5	1.35 H	166	41.70	16.80
6	10640.00	47.2 AV	54.0	-6.8	1.35 H	166	30.40	16.80

ANTENNA POLARITY & TEST DISTANCE: VERTICAL AT 3 M								
NO.	FREQ. (MHz)	EMISSION LEVEL (dBuV/m)	LIMIT (dBuV/m)	MARGIN (dB)	ANTENNA HEIGHT (m)	TABLE ANGLE (Degree)	RAW VALUE (dBuV)	CORRECTION FACTOR (dB/m)
1	*5320.00	99.6 PK			2.38 V	190	60.20	39.40
2	*5320.00	89.3 AV			2.38 V	190	49.90	39.40
3	5350.00	55.1 PK	74.0	-18.9	2.38 V	190	49.60	5.50
4	5350.00	44.8 AV	54.0	-9.2	2.38 V	190	39.30	5.50
5	10640.00	58.4 PK	74.0	-15.6	1.25 V	96	41.60	16.80
6	10640.00	47.0 AV	54.0	-7.0	1.25 V	96	30.20	16.80

REMARKS:

1. Emission Level(dBuV/m) = Raw Value(dBuV) + Correction Factor(dB/m)
2. Correction Factor(dB/m) = Antenna Factor(dB/m) + Cable Factor(dB)
– Pre-Amplifier Factor(dB)
3. The other emission levels were very low against the limit.
4. Margin value = Emission Level – Limit value
5. “ * ”: Fundamental frequency.

EUT TEST CONDITION		MEASUREMENT DETAIL	
CHANNEL	Channel 100	FREQUENCY RANGE	1 ~ 40GHz
INPUT POWER	120Vac, 60Hz	DETECTOR FUNCTION	Peak (PK) Average (AV)
ENVIRONMENTAL CONDITIONS	22deg. C, 69%RH	TESTED BY	Jones Chang

ANTENNA POLARITY & TEST DISTANCE: HORIZONTAL AT 3 M								
NO.	FREQ. (MHz)	EMISSION LEVEL (dBuV/m)	LIMIT (dBuV/m)	MARGIN (dB)	ANTENNA HEIGHT (m)	TABLE ANGLE (Degree)	RAW VALUE (dBuV)	CORRECTION FACTOR (dB/m)
1	5460.00	56.9 PK	74.0	-17.1	1.22 H	90	51.30	5.60
2	5460.00	45.3 AV	54.0	-8.7	1.22 H	90	39.70	5.60
3	#5470.00	57.6 PK	74.0	-16.4	1.22 H	90	52.00	5.60
4	#5470.00	46.0 AV	54.0	-8.0	1.22 H	90	40.40	5.60
5	*5500.00	104.6 PK			1.22 H	90	65.00	39.60
6	*5500.00	94.3 AV			1.22 H	90	54.70	39.60
7	11000.00	60.1 PK	74.0	-13.9	1.26 H	142	41.60	18.50
8	11000.00	48.8 AV	54.0	-5.2	1.26 H	142	30.30	18.50
ANTENNA POLARITY & TEST DISTANCE: VERTICAL AT 3 M								
NO.	FREQ. (MHz)	EMISSION LEVEL (dBuV/m)	LIMIT (dBuV/m)	MARGIN (dB)	ANTENNA HEIGHT (m)	TABLE ANGLE (Degree)	RAW VALUE (dBuV)	CORRECTION FACTOR (dB/m)
1	5460.00	57.6 PK	74.0	-16.4	1.58 V	157	52.00	5.60
2	5460.00	45.6 AV	54.0	-8.4	1.58 V	157	40.00	5.60
3	#5470.00	58.6 PK	74.0	-15.4	1.58 V	157	53.00	5.60
4	#5470.00	46.5 AV	54.0	-7.5	1.58 V	157	40.90	5.60
5	*5500.00	99.6 PK			1.58 V	157	60.00	39.60
6	*5500.00	89.6 AV			1.58 V	157	50.00	39.60
7	11000.00	60.0 PK	74.0	-14.0	1.00 V	99	41.50	18.50
8	11000.00	48.8 AV	54.0	-5.2	1.00 V	99	30.30	18.50

REMARKS:

1. Emission Level(dBuV/m) = Raw Value(dBuV) + Correction Factor(dB/m)
2. Correction Factor(dB/m) = Antenna Factor(dB/m) + Cable Factor(dB)
– Pre-Amplifier Factor(dB)
3. The other emission levels were very low against the limit.
4. Margin value = Emission Level – Limit value
5. “ * “: Fundamental frequency.
6. "#":The radiated frequency is out the restricted band.



A D T

EUT TEST CONDITION		MEASUREMENT DETAIL	
CHANNEL	Channel 116	FREQUENCY RANGE	1 ~ 40GHz
INPUT POWER	120Vac, 60Hz	DETECTOR FUNCTION	Peak (PK) Average (AV)
ENVIRONMENTAL CONDITIONS	22deg. C, 69%RH	TESTED BY	Jones Chang

ANTENNA POLARITY & TEST DISTANCE: HORIZONTAL AT 3 M								
NO.	FREQ. (MHz)	EMISSION LEVEL (dBuV/m)	LIMIT (dBuV/m)	MARGIN (dB)	ANTENNA HEIGHT (m)	TABLE ANGLE (Degree)	RAW VALUE (dBuV)	CORRECTION FACTOR (dB/m)
1	*5580.00	104.7 PK			1.30 H	77	64.90	39.80
2	*5580.00	94.2 AV			1.30 H	77	54.40	39.80
3	11160.00	60.0 PK	74.0	-14.0	1.36 H	63	41.60	18.40
4	11160.00	48.8 AV	54.0	-5.2	1.36 H	63	30.40	18.40
ANTENNA POLARITY & TEST DISTANCE: VERTICAL AT 3 M								
NO.	FREQ. (MHz)	EMISSION LEVEL (dBuV/m)	LIMIT (dBuV/m)	MARGIN (dB)	ANTENNA HEIGHT (m)	TABLE ANGLE (Degree)	RAW VALUE (dBuV)	CORRECTION FACTOR (dB/m)
1	*5580.00	99.8 PK			1.65 V	160	60.00	39.80
2	*5580.00	89.6 AV			1.65 V	160	49.80	39.80
3	11160.00	59.9 PK	74.0	-14.1	1.03 V	142	41.50	18.40
4	11160.00	48.7 AV	54.0	-5.3	1.03 V	142	30.30	18.40

REMARKS:

1. Emission Level(dBuV/m) = Raw Value(dBuV) + Correction Factor(dB/m)
2. Correction Factor(dB/m) = Antenna Factor(dB/m) + Cable Factor(dB) – Pre-Amplifier Factor(dB)
3. The other emission levels were very low against the limit.
4. Margin value = Emission Level – Limit value
5. “ * “: Fundamental frequency.



A D T

EUT TEST CONDITION		MEASUREMENT DETAIL	
CHANNEL	Channel 140	FREQUENCY RANGE	1 ~ 40GHz
INPUT POWER	120Vac, 60Hz	DETECTOR FUNCTION	Peak (PK) Average (AV)
ENVIRONMENTAL CONDITIONS	22deg. C, 69%RH	TESTED BY	Jones Chang

ANTENNA POLARITY & TEST DISTANCE: HORIZONTAL AT 3 M								
NO.	FREQ. (MHz)	EMISSION LEVEL (dBuV/m)	LIMIT (dBuV/m)	MARGIN (dB)	ANTENNA HEIGHT (m)	TABLE ANGLE (Degree)	RAW VALUE (dBuV)	CORRECTION FACTOR (dB/m)
1	*5700.00	105.0 PK			1.27 H	85	64.90	40.10
2	*5700.00	94.5 AV			1.27 H	85	54.40	40.10
3	#5725.00	59.9 PK	74.0	-14.1	1.27 H	85	53.60	6.30
4	#5725.00	47.5 AV	54.0	-6.5	1.27 H	85	41.20	6.30
5	11400.00	59.8 PK	74.0	-14.2	1.32 H	150	41.60	18.20
6	11400.00	48.6 AV	54.0	-5.4	1.32 H	150	30.40	18.20
ANTENNA POLARITY & TEST DISTANCE: VERTICAL AT 3 M								
NO.	FREQ. (MHz)	EMISSION LEVEL (dBuV/m)	LIMIT (dBuV/m)	MARGIN (dB)	ANTENNA HEIGHT (m)	TABLE ANGLE (Degree)	RAW VALUE (dBuV)	CORRECTION FACTOR (dB/m)
1	*5700.00	99.8 PK			1.68 V	180	59.70	40.10
2	*5700.00	89.4 AV			1.68 V	180	49.30	40.10
3	#5725.00	59.3 PK	74.0	-14.7	1.68 V	180	53.00	6.30
4	#5725.00	47.1 AV	54.0	-6.9	1.68 V	180	40.80	6.30
5	11400.00	59.5 PK	74.0	-14.5	1.09 V	122	41.30	18.20
6	11400.00	48.3 AV	54.0	-5.7	1.09 V	122	30.10	18.20

REMARKS:

1. Emission Level(dBuV/m) = Raw Value(dBuV) + Correction Factor(dB/m)
2. Correction Factor(dB/m) = Antenna Factor(dB/m) + Cable Factor(dB) – Pre-Amplifier Factor(dB)
3. The other emission levels were very low against the limit.
4. Margin value = Emission Level – Limit value
5. “ * “: Fundamental frequency.
6. “#”:The radiated frequency is out the restricted band.



A D T

802.11n (40MHz)

EUT TEST CONDITION		MEASUREMENT DETAIL	
CHANNEL	Channel 38	FREQUENCY RANGE	1 ~ 40GHz
INPUT POWER	120Vac, 60Hz	DETECTOR FUNCTION	Peak (PK) Average (AV)
ENVIRONMENTAL CONDITIONS	22deg. C, 69%RH	TESTED BY	Jones Chang

ANTENNA POLARITY & TEST DISTANCE: HORIZONTAL AT 3 M								
NO.	FREQ. (MHz)	EMISSION LEVEL (dBuV/m)	LIMIT (dBuV/m)	MARGIN (dB)	ANTENNA HEIGHT (m)	TABLE ANGLE (Degree)	RAW VALUE (dBuV)	CORRECTION FACTOR (dB/m)
1	5150.00	65.5 PK	74.0	-8.5	1.26 H	82	60.10	5.40
2	5150.00	51.5 AV	54.0	-2.5	1.26 H	82	46.10	5.40
3	*5190.00	101.6 PK			1.26 H	82	62.30	39.30
4	*5190.00	91.8 AV			1.26 H	82	52.50	39.30
5	#10380.00	60.7 PK	74.0	-13.3	1.17 H	158	44.60	16.10
6	#10380.00	48.1 AV	54.0	-5.9	1.17 H	158	32.00	16.10

ANTENNA POLARITY & TEST DISTANCE: VERTICAL AT 3 M								
NO.	FREQ. (MHz)	EMISSION LEVEL (dBuV/m)	LIMIT (dBuV/m)	MARGIN (dB)	ANTENNA HEIGHT (m)	TABLE ANGLE (Degree)	RAW VALUE (dBuV)	CORRECTION FACTOR (dB/m)
1	5150.00	64.4 PK	74.0	-9.6	1.55 V	75	59.00	5.40
2	5150.00	50.3 AV	54.0	-3.7	1.55 V	75	44.90	5.40
3	*5190.00	97.8 PK			1.55 V	75	58.50	39.30
4	*5190.00	88.0 AV			1.55 V	75	48.70	39.30
5	#10380.00	60.5 PK	74.0	-13.5	1.13 V	13	44.40	16.10
6	#10380.00	47.9 AV	54.0	-6.1	1.13 V	13	31.80	16.10

REMARKS:

1. Emission Level(dBuV/m) = Raw Value(dBuV) + Correction Factor(dB/m)
2. Correction Factor(dB/m) = Antenna Factor(dB/m) + Cable Factor(dB)
– Pre-Amplifier Factor(dB)
3. The other emission levels were very low against the limit.
4. Margin value = Emission Level – Limit value
5. “ * “: Fundamental frequency.
6. “#”:The radiated frequency is out the restricted band.



A D T

EUT TEST CONDITION		MEASUREMENT DETAIL	
CHANNEL	Channel 46	FREQUENCY RANGE	1 ~ 40GHz
INPUT POWER	120Vac, 60Hz	DETECTOR FUNCTION	Peak (PK) Average (AV)
ENVIRONMENTAL CONDITIONS	22deg. C, 69%RH	TESTED BY	Jones Chang

ANTENNA POLARITY & TEST DISTANCE: HORIZONTAL AT 3 M								
NO.	FREQ. (MHz)	EMISSION LEVEL (dBuV/m)	LIMIT (dBuV/m)	MARGIN (dB)	ANTENNA HEIGHT (m)	TABLE ANGLE (Degree)	RAW VALUE (dBuV)	CORRECTION FACTOR (dB/m)
1	*5230.00	101.8 PK			1.23 H	80	62.50	39.30
2	*5230.00	92.0 AV			1.23 H	80	52.70	39.30
3	#10460.00	61.1 PK	74.0	-12.9	1.11 H	156	44.50	16.60
4	#10460.00	48.5 AV	54.0	-5.5	1.11 H	156	31.90	16.60
ANTENNA POLARITY & TEST DISTANCE: VERTICAL AT 3 M								
NO.	FREQ. (MHz)	EMISSION LEVEL (dBuV/m)	LIMIT (dBuV/m)	MARGIN (dB)	ANTENNA HEIGHT (m)	TABLE ANGLE (Degree)	RAW VALUE (dBuV)	CORRECTION FACTOR (dB/m)
1	*5230.00	97.8 PK			1.50 V	71	58.50	39.30
2	*5230.00	88.0 AV			1.50 V	71	48.70	39.30
3	#10460.00	61.0 PK	74.0	-13.0	1.03 V	22	44.40	16.60
4	#10460.00	48.4 AV	54.0	-5.6	1.03 V	22	31.80	16.60

REMARKS:

1. Emission Level(dBuV/m) = Raw Value(dBuV) + Correction Factor(dB/m)
2. Correction Factor(dB/m) = Antenna Factor(dB/m) + Cable Factor(dB)
– Pre-Amplifier Factor(dB)
3. The other emission levels were very low against the limit.
4. Margin value = Emission Level – Limit value
5. “ * “: Fundamental frequency.
6. “#”:The radiated frequency is out the restricted band.



A D T

EUT TEST CONDITION		MEASUREMENT DETAIL	
CHANNEL	Channel 54	FREQUENCY RANGE	1 ~ 40GHz
INPUT POWER	120Vac, 60Hz	DETECTOR FUNCTION	Peak (PK) Average (AV)
ENVIRONMENTAL CONDITIONS	22deg. C, 69%RH	TESTED BY	Jones Chang

ANTENNA POLARITY & TEST DISTANCE: HORIZONTAL AT 3 M								
NO.	FREQ. (MHz)	EMISSION LEVEL (dBuV/m)	LIMIT (dBuV/m)	MARGIN (dB)	ANTENNA HEIGHT (m)	TABLE ANGLE (Degree)	RAW VALUE (dBuV)	CORRECTION FACTOR (dB/m)
1	*5270.00	100.9 PK			1.55 H	79	61.50	39.40
2	*5270.00	90.7 AV			1.55 H	79	51.30	39.40
3	#10540.00	60.3 PK	74.0	-13.7	1.08 H	12	43.60	16.70
4	#10540.00	47.9 AV	54.0	-6.1	1.08 H	12	31.20	16.70
ANTENNA POLARITY & TEST DISTANCE: VERTICAL AT 3 M								
NO.	FREQ. (MHz)	EMISSION LEVEL (dBuV/m)	LIMIT (dBuV/m)	MARGIN (dB)	ANTENNA HEIGHT (m)	TABLE ANGLE (Degree)	RAW VALUE (dBuV)	CORRECTION FACTOR (dB/m)
1	*5270.00	96.9 PK			1.55 V	79	57.50	39.40
2	*5270.00	86.7 AV			1.55 V	79	47.30	39.40
3	#10540.00	60.2 PK	74.0	-13.8	1.08 V	12	43.50	16.70
4	#10540.00	47.8 AV	54.0	-6.2	1.08 V	12	31.10	16.70

REMARKS:

1. Emission Level(dBuV/m) = Raw Value(dBuV) + Correction Factor(dB/m)
2. Correction Factor(dB/m) = Antenna Factor(dB/m) + Cable Factor(dB)
– Pre-Amplifier Factor(dB)
3. The other emission levels were very low against the limit.
4. Margin value = Emission Level – Limit value
5. “ * “: Fundamental frequency.
6. “#”:The radiated frequency is out the restricted band.



EUT TEST CONDITION		MEASUREMENT DETAIL	
CHANNEL	Channel 62	FREQUENCY RANGE	1 ~ 40GHz
INPUT POWER	120Vac, 60Hz	DETECTOR FUNCTION	Peak (PK) Average (AV)
ENVIRONMENTAL CONDITIONS	22deg. C, 69%RH	TESTED BY	Jones Chang

ANTENNA POLARITY & TEST DISTANCE: HORIZONTAL AT 3 M								
NO.	FREQ. (MHz)	EMISSION LEVEL (dBuV/m)	LIMIT (dBuV/m)	MARGIN (dB)	ANTENNA HEIGHT (m)	TABLE ANGLE (Degree)	RAW VALUE (dBuV)	CORRECTION FACTOR (dB/m)
1	*5310.00	100.8 PK			1.37 H	115	61.40	39.40
2	*5310.00	90.6 AV			1.37 H	115	51.20	39.40
3	5350.00	67.4 PK	74.0	-6.6	1.37 H	115	61.90	5.50
4	5350.00	46.9 AV	54.0	-7.1	1.37 H	115	41.40	5.50
5	10620.00	60.5 PK	74.0	-13.5	1.12 H	135	43.80	16.70
6	10620.00	48.2 AV	54.0	-5.8	1.12 H	135	31.50	16.70

ANTENNA POLARITY & TEST DISTANCE: VERTICAL AT 3 M								
NO.	FREQ. (MHz)	EMISSION LEVEL (dBuV/m)	LIMIT (dBuV/m)	MARGIN (dB)	ANTENNA HEIGHT (m)	TABLE ANGLE (Degree)	RAW VALUE (dBuV)	CORRECTION FACTOR (dB/m)
1	*5310.00	97.0 PK			1.55 V	79	57.60	39.40
2	*5310.00	86.8 AV			1.55 V	79	47.40	39.40
3	5350.00	65.5 PK	74.0	-8.5	1.55 V	79	60.00	5.50
4	5350.00	44.9 AV	54.0	-9.1	1.55 V	79	39.40	5.50
5	10620.00	60.4 PK	74.0	-13.6	1.08 V	12	43.70	16.70
6	10620.00	48.0 AV	54.0	-6.0	1.08 V	12	31.30	16.70

REMARKS:

1. Emission Level(dBuV/m) = Raw Value(dBuV) + Correction Factor(dB/m)
2. Correction Factor(dB/m) = Antenna Factor(dB/m) + Cable Factor(dB)
– Pre-Amplifier Factor(dB)
3. The other emission levels were very low against the limit.
4. Margin value = Emission Level – Limit value
5. “ * ”: Fundamental frequency.

EUT TEST CONDITION		MEASUREMENT DETAIL	
CHANNEL	Channel 102	FREQUENCY RANGE	1 ~ 40GHz
INPUT POWER	120Vac, 60Hz	DETECTOR FUNCTION	Peak (PK) Average (AV)
ENVIRONMENTAL CONDITIONS	22deg. C, 69%RH	TESTED BY	Jones Chang

ANTENNA POLARITY & TEST DISTANCE: HORIZONTAL AT 3 M								
NO.	FREQ. (MHz)	EMISSION LEVEL (dBuV/m)	LIMIT (dBuV/m)	MARGIN (dB)	ANTENNA HEIGHT (m)	TABLE ANGLE (Degree)	RAW VALUE (dBuV)	CORRECTION FACTOR (dB/m)
1	5460.00	64.8 PK	74.0	-9.2	1.53 H	112	59.20	5.60
2	5460.00	46.7 AV	54.0	-7.3	1.53 H	112	41.10	5.60
3	#5470.00	70.4 PK	74.0	-3.6	1.53 H	112	64.80	5.60
4	#5470.00	49.5 AV	54.0	-4.5	1.53 H	112	43.90	5.60
5	*5510.00	101.5 PK			1.53 H	112	61.90	39.60
6	*5510.00	90.8 AV			1.53 H	112	51.20	39.60
7	11020.00	60.1 PK	74.0	-13.9	1.28 H	75	41.50	18.60
8	11020.00	47.8 AV	54.0	-6.2	1.28 H	75	29.20	18.60
ANTENNA POLARITY & TEST DISTANCE: VERTICAL AT 3 M								
NO.	FREQ. (MHz)	EMISSION LEVEL (dBuV/m)	LIMIT (dBuV/m)	MARGIN (dB)	ANTENNA HEIGHT (m)	TABLE ANGLE (Degree)	RAW VALUE (dBuV)	CORRECTION FACTOR (dB/m)
1	5460.00	61.6 PK	74.0	-12.4	1.50 V	90	56.00	5.60
2	5460.00	44.6 AV	54.0	-9.4	1.50 V	90	39.00	5.60
3	#5470.00	65.8 PK	74.0	-8.2	1.50 V	90	60.20	5.60
4	#5470.00	45.5 AV	54.0	-8.5	1.50 V	90	39.90	5.60
5	*5510.00	97.5 PK			1.50 V	90	57.90	39.60
6	*5510.00	87.0 AV			1.50 V	90	47.40	39.60
7	11020.00	60.1 PK	74.0	-13.9	1.12 V	128	41.50	18.60
8	11020.00	47.7 AV	54.0	-6.3	1.12 V	128	29.10	18.60

REMARKS:

1. Emission Level(dBuV/m) = Raw Value(dBuV) + Correction Factor(dB/m)
2. Correction Factor(dB/m) = Antenna Factor(dB/m) + Cable Factor(dB)
– Pre-Amplifier Factor(dB)
3. The other emission levels were very low against the limit.
4. Margin value = Emission Level – Limit value
5. “ * “: Fundamental frequency.
6. “#”:The radiated frequency is out the restricted band.



A D T

EUT TEST CONDITION		MEASUREMENT DETAIL	
CHANNEL	Channel 110	FREQUENCY RANGE	1 ~ 40GHz
INPUT POWER	120Vac, 60Hz	DETECTOR FUNCTION	Peak (PK) Average (AV)
ENVIRONMENTAL CONDITIONS	22deg. C, 69%RH	TESTED BY	Jones Chang

ANTENNA POLARITY & TEST DISTANCE: HORIZONTAL AT 3 M								
NO.	FREQ. (MHz)	EMISSION LEVEL (dBuV/m)	LIMIT (dBuV/m)	MARGIN (dB)	ANTENNA HEIGHT (m)	TABLE ANGLE (Degree)	RAW VALUE (dBuV)	CORRECTION FACTOR (dB/m)
1	*5550.00	101.8 PK			1.31 H	70	62.00	39.80
2	*5550.00	91.4 AV			1.31 H	70	51.60	39.80
3	11100.00	60.2 PK	74.0	-13.8	1.10 H	199	41.60	18.60
4	11100.00	48.0 AV	54.0	-6.0	1.10 H	199	29.40	18.60
ANTENNA POLARITY & TEST DISTANCE: VERTICAL AT 3 M								
NO.	FREQ. (MHz)	EMISSION LEVEL (dBuV/m)	LIMIT (dBuV/m)	MARGIN (dB)	ANTENNA HEIGHT (m)	TABLE ANGLE (Degree)	RAW VALUE (dBuV)	CORRECTION FACTOR (dB/m)
1	*5550.00	97.8 PK			1.46 V	85	58.00	39.80
2	*5550.00	87.4 AV			1.46 V	85	47.60	39.80
3	11100.00	60.1 PK	74.0	-13.9	1.06 V	139	41.50	18.60
4	11100.00	47.7 AV	54.0	-6.3	1.06 V	139	29.10	18.60

REMARKS:

1. Emission Level(dBuV/m) = Raw Value(dBuV) + Correction Factor(dB/m)
2. Correction Factor(dB/m) = Antenna Factor(dB/m) + Cable Factor(dB)
– Pre-Amplifier Factor(dB)
3. The other emission levels were very low against the limit.
4. Margin value = Emission Level – Limit value
5. “ * “: Fundamental frequency.



EUT TEST CONDITION		MEASUREMENT DETAIL	
CHANNEL	Channel 134	FREQUENCY RANGE	1 ~ 40GHz
INPUT POWER	120Vac, 60Hz	DETECTOR FUNCTION	Peak (PK) Average (AV)
ENVIRONMENTAL CONDITIONS	22deg. C, 69%RH	TESTED BY	Jones Chang

ANTENNA POLARITY & TEST DISTANCE: HORIZONTAL AT 3 M								
NO.	FREQ. (MHz)	EMISSION LEVEL (dBuV/m)	LIMIT (dBuV/m)	MARGIN (dB)	ANTENNA HEIGHT (m)	TABLE ANGLE (Degree)	RAW VALUE (dBuV)	CORRECTION FACTOR (dB/m)
1	*5670.00	100.4 PK			1.50 H	111	60.40	40.00
2	*5670.00	90.1 AV			1.50 H	111	50.10	40.00
3	#5725.00	58.6 PK	74.0	-15.4	1.50 H	111	52.30	6.30
4	#5725.00	46.2 AV	54.0	-7.8	1.50 H	111	39.90	6.30
5	11340.00	60.0 PK	74.0	-14.0	1.26 H	80	41.70	18.30
6	11340.00	47.7 AV	54.0	-6.3	1.26 H	80	29.40	18.30
ANTENNA POLARITY & TEST DISTANCE: VERTICAL AT 3 M								
NO.	FREQ. (MHz)	EMISSION LEVEL (dBuV/m)	LIMIT (dBuV/m)	MARGIN (dB)	ANTENNA HEIGHT (m)	TABLE ANGLE (Degree)	RAW VALUE (dBuV)	CORRECTION FACTOR (dB/m)
1	*5670.00	96.4 PK			1.41 V	53	56.40	40.00
2	*5670.00	86.3 AV			1.41 V	53	46.30	40.00
3	#5725.00	56.3 PK	74.0	-17.7	1.41 V	53	50.00	6.30
4	#5725.00	43.4 AV	54.0	-10.6	1.41 V	53	37.10	6.30
5	11340.00	59.9 PK	74.0	-14.1	1.42 V	150	41.60	18.30
6	11340.00	47.5 AV	54.0	-6.5	1.42 V	150	29.20	18.30

REMARKS:

1. Emission Level(dBuV/m) = Raw Value(dBuV) + Correction Factor(dB/m)
2. Correction Factor(dB/m) = Antenna Factor(dB/m) + Cable Factor(dB) – Pre-Amplifier Factor(dB)
3. The other emission levels were very low against the limit.
4. Margin value = Emission Level – Limit value
5. “ * “: Fundamental frequency.
6. “#”:The radiated frequency is out the restricted band.

BELOW 1GHz WORST-CASE DATA : 802.11a

EUT TEST CONDITION		MEASUREMENT DETAIL	
CHANNEL	Channel 48	FREQUENCY RANGE	Below 1000MHz
INPUT POWER	120Vac, 60Hz	DETECTOR FUNCTION	Quasi-Peak
ENVIRONMENTAL CONDITIONS	22deg. C, 69%RH	TESTED BY	Brad Tung

ANTENNA POLARITY & TEST DISTANCE: HORIZONTAL AT 3 M								
NO.	FREQ. (MHz)	EMISSION LEVEL (dBuV/m)	LIMIT (dBuV/m)	MARGIN (dB)	ANTENNA HEIGHT (m)	TABLE ANGLE (Degree)	RAW VALUE (dBuV)	CORRECTION FACTOR (dB/m)
1	144.03	35.8 QP	43.5	-7.7	2.00 H	156	49.70	-13.90
2	382.05	29.1 QP	46.0	-16.9	2.00 H	17	40.20	-11.10
3	430.77	33.8 QP	46.0	-12.2	1.25 H	93	43.80	-10.00
4	528.96	33.5 QP	46.0	-12.5	1.00 H	248	42.10	-8.60
5	577.74	41.8 QP	46.0	-4.2	1.25 H	175	49.30	-7.50
6	743.47	32.5 QP	46.0	-13.5	2.00 H	6	36.60	-4.10

ANTENNA POLARITY & TEST DISTANCE: VERTICAL AT 3 M								
NO.	FREQ. (MHz)	EMISSION LEVEL (dBuV/m)	LIMIT (dBuV/m)	MARGIN (dB)	ANTENNA HEIGHT (m)	TABLE ANGLE (Degree)	RAW VALUE (dBuV)	CORRECTION FACTOR (dB/m)
1	58.17	27.2 QP	40.0	-12.8	1.50 V	320	42.10	-14.90
2	167.22	25.8 QP	43.5	-17.7	1.25 V	259	40.20	-14.40
3	528.85	34.0 QP	46.0	-12.0	1.00 V	14	42.60	-8.60
4	575.79	42.4 QP	46.0	-3.6	1.25 V	130	50.00	-7.60
5	594.68	34.4 QP	46.0	-11.6	1.00 V	22	41.50	-7.10
6	623.18	31.3 QP	46.0	-14.7	1.00 V	75	37.70	-6.40

REMARKS:

1. Emission Level(dBuV/m) = Raw Value(dBuV) + Correction Factor(dB/m)
2. Correction Factor(dB/m) = Antenna Factor(dB/m) + Cable Factor(dB)
– Pre-Amplifier Factor (dB)
3. The other emission levels were very low against the limit.
4. Margin value = Emission Level – Limit value

4.2 CONDUCTED EMISSION MEASUREMENT

4.2.1 LIMITS OF CONDUCTED EMISSION MEASUREMENT

FREQUENCY OF EMISSION (MHz)	CONDUCTED LIMIT (dB μ V)	
	Quasi-peak	Average
0.15 ~ 0.5	66 to 56	56 to 46
0.5 ~ 5	56	46
5 ~ 30	60	50

- NOTE:**
1. The lower limit shall apply at the transition frequencies.
 2. The limit decreases in line with the logarithm of the frequency in the range of 0.15 to 0.50MHz.
 3. All emanations from a class A/B digital device or system, including any network of conductors and apparatus connected thereto, shall not exceed the level of field strengths specified above.

4.2.2 TEST INSTRUMENTS

DESCRIPTION & MANUFACTURER	MODEL NO.	SERIAL NO.	DATE OF CALIBRATION	DUE DATE OF CALIBRATION
Test Receiver ROHDE & SCHWARZ	ESCS30	100289	Nov. 29, 2013	Nov. 28, 2014
RF signal cable Woken	5D-FB	Cable-HYC01-01	Dec. 28, 2012	Dec. 27, 2013
LISN ROHDE & SCHWARZ (Peripheral)	ESH3-Z5	100312	Jul. 08, 2013	Jul. 07, 2014
LISN ROHDE & SCHWARZ (EUT)	ESH3-Z5	835239/001	Feb. 04, 2013	Feb. 03, 2014
Software ADT	BV ADT_Cond_ V7.3.7.3	NA	NA	NA

- NOTE:**
1. The calibration interval of the above test instruments is 12 months and the calibrations are traceable to NML/ROC and NIST/USA.
 2. The test was performed in HwaYa Shielded Room 1.
 3. The VCCI Site Registration No. is C-2040.

4.2.3 TEST PROCEDURES

- The EUT was placed 0.4 meters from the conducting wall of the shielded room with EUT being connected to the power mains through a line impedance stabilization network (LISN). Other support units were connected to the power mains through another LISN. The two LISNs provide 50 ohm/ 50uH of coupling impedance for the measuring instrument.
- Both lines of the power mains connected to the EUT were checked for maximum conducted interference.
- The frequency range from 150kHz to 30MHz was searched. Emission levels under (Limit - 20dB) was not recorded.

NOTE: All modes of operation were investigated and the worst-case emissions are reported.

4.2.4 DEVIATION FROM TEST STANDARD

No deviation.

4.2.5 TEST SETUP

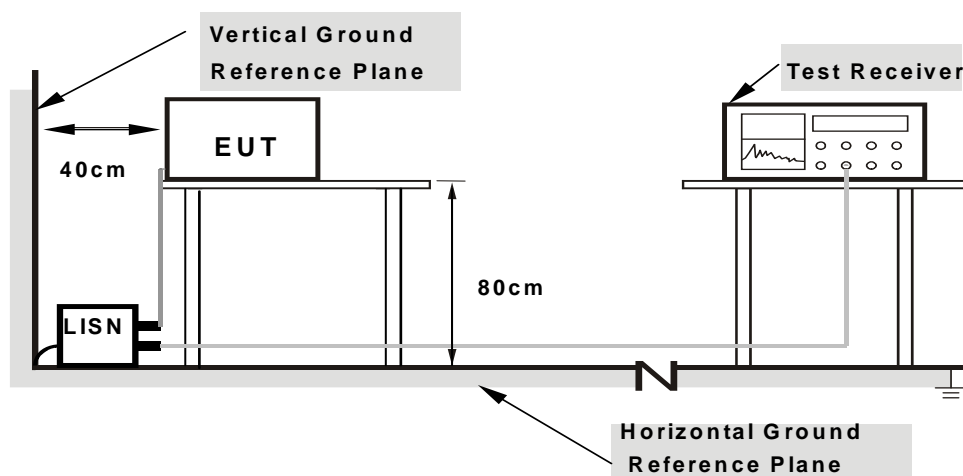

- Note:**
- Support units were connected to second LISN.
 - Both of LISNs (AMN) are 80 cm from EUT and at least 80 from other units and other metal planes

For the actual test configuration, please refer to the attached file (Test Setup Photo).

4.2.6 EUT OPERATING CONDITIONS

Same as 4.1.6.

4.2.7 TEST RESULTS

CONDUCTED WORST-CASE DATA : 802.11a

PHASE	Line 1	6dB BANDWIDTH	9kHz
--------------	--------	----------------------	------

No	Freq. [MHz]	Corr. Factor (dB)	Reading Value		Emission Level		Limit		Margin	
			[dB (uV)]		[dB (uV)]		[dB (uV)]		(dB)	
			Q.P.	AV.	Q.P.	AV.	Q.P.	AV.	Q.P.	AV.
1	0.18122	0.16	45.20	26.11	45.36	26.27	64.43	54.43	-19.07	-28.16
2	0.23211	0.17	41.28	22.26	41.45	22.43	62.37	52.37	-20.92	-29.94
3	0.26339	0.18	39.19	20.61	39.37	20.79	61.32	51.32	-21.95	-30.53
4	0.32986	0.21	33.90	16.23	34.11	16.44	59.45	49.45	-25.35	-33.02
5	0.42863	0.23	36.46	23.46	36.69	23.69	57.28	47.28	-20.59	-23.59
6	16.74013	1.06	25.09	16.51	26.15	17.57	60.00	50.00	-33.85	-32.43

REMARKS:

1. Q.P. and AV. are abbreviations of quasi-peak and average individually.
2. The emission levels of other frequencies were very low against the limit.
3. Margin value = Emission level - Limit value
4. Correction factor = Insertion loss + Cable loss
5. Emission Level = Correction Factor + Reading Value

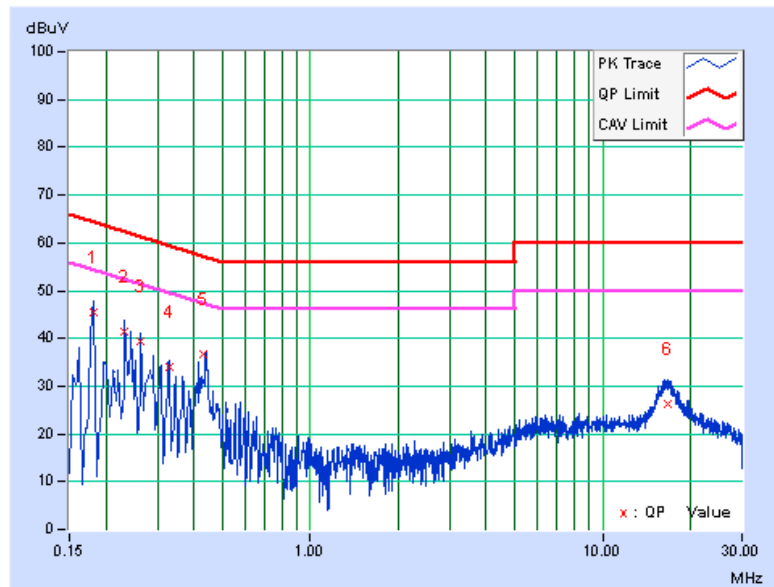



A D T

PHASE	Line 2	6dB BANDWIDTH	9kHz
-------	--------	---------------	------

No	Freq. [MHz]	Corr. Factor (dB)	Reading Value		Emission Level		Limit		Margin	
			[dB (uV)]		[dB (uV)]		[dB (uV)]		(dB)	
			Q.P.	AV.	Q.P.	AV.	Q.P.	AV.	Q.P.	AV.
1	0.16564	0.17	44.63	20.73	44.80	20.90	65.18	55.18	-20.38	-34.28
2	0.18170	0.17	45.37	24.24	45.54	24.41	64.41	54.41	-18.87	-30.00
3	0.26730	0.19	39.16	19.43	39.35	19.62	61.20	51.20	-21.85	-31.58
4	0.33308	0.22	33.40	14.17	33.62	14.39	59.37	49.37	-25.76	-34.99
5	0.42993	0.24	37.07	24.55	37.31	24.79	57.25	47.25	-19.94	-22.46
6	16.41951	0.81	21.22	12.91	22.03	13.72	60.00	50.00	-37.97	-36.28

REMARKS:

1. Q.P. and AV. are abbreviations of quasi-peak and average individually.
2. The emission levels of other frequencies were very low against the limit.
3. Margin value = Emission level - Limit value
4. Correction factor = Insertion loss + Cable loss
5. Emission Level = Correction Factor + Reading Value

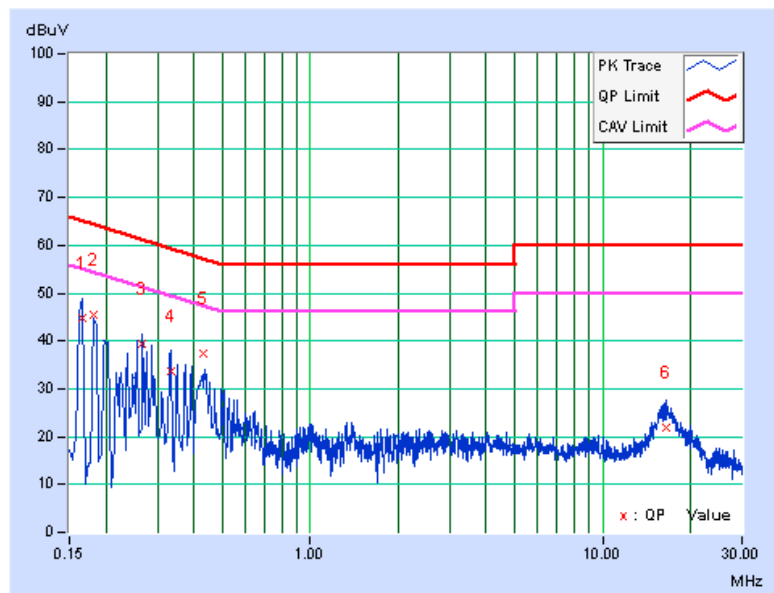

4.3 PEAK TRANSMIT POWER MEASUREMENT

4.3.1 LIMITS OF PEAK TRANSMIT POWER MEASUREMENT

FREQUENCY BAND	LIMIT
5.150 ~ 5.250GHz	The lesser of 50mW (17dBm) or 4dBm + 10logB
5.250 ~ 5.350GHz	The lesser of 250mW (24dBm) or 11dBm + 10logB
5.470 ~ 5.725GHz	The lesser of 250mW (24dBm) or 11dBm + 10logB

NOTE: Where B is the 26dB emission bandwidth in MHz.

4.3.2 TEST SETUP

FOR POWER OUTPUT MEASUREMENT

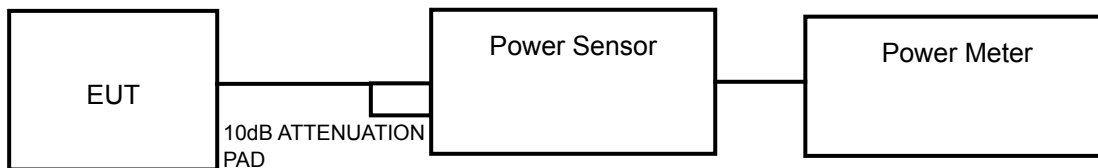

FOR 26dB BANDWIDTH

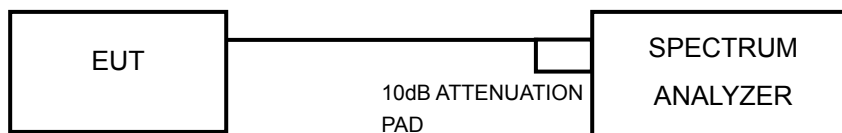

4.3.3 TEST INSTRUMENTS

Refer to section 4.1.3 to get information of above instrument.

4.3.4 TEST PROCEDURE

FOR AVERAGE POWER MEASUREMENT

Method PM is used to perform output power measurement, trigger and gating function of wide band power meter is enabled to measure max output power of TX on burst. Duty factor is not added to measured value.

FOR 26dB BANDWIDTH

- 1) Set RBW = approximately 1% of the emission bandwidth.
- 2) Set the VBW > RBW.
- 3) Detector = Peak.
- 4) Trace mode = max hold.
- 5) Measure the maximum width of the emission that is 26 dB down from the peak of the emission. Compare this with the RBW setting of the analyzer. Readjust RBW and repeat measurement as needed until the RBW/EBW ratio is approximately 1%.

4.3.5 DEVIATION FROM TEST STANDARD

No deviation.

4.3.6 EUT OPERATING CONDITIONS

The software provided by client to enable the EUT under transmission condition continuously at specific channel frequencies individually.

4.3.7 TEST RESULTS

POWER OUTPUT:

802.11a

CHANNEL	CHANNEL FREQUENCY (MHz)	AVERAGE POWER (mW)	AVERAGE POWER (dBm)	POWER LIMIT (dBm)	PASS/FAIL
36	5180	20.893	13.20	17	PASS
40	5200	21.330	13.29	17	PASS
48	5240	21.478	13.32	17	PASS
52	5260	20.941	13.21	24	PASS
60	5300	21.184	13.26	24	PASS
64	5320	20.797	13.18	24	PASS
100	5500	20.893	13.20	24	PASS
116	5580	20.137	13.04	24	PASS
140	5700	20.559	13.13	24	PASS

NOTE:

For 5180~5240MHz:

1. $4\text{dBm} + 10\log (23.59) = 17.73 > 17\text{dBm}$
2. $4\text{dBm} + 10\log (24.06) = 17.81 > 17\text{dBm}$
3. $4\text{dBm} + 10\log (24.16) = 17.83 > 17\text{dBm}$

For 5260~5700MHz:

1. $11\text{dBm} + 10\log (23.91) = 24.79 > 24\text{dBm}$
2. $11\text{dBm} + 10\log (23.83) = 24.77 > 24\text{dBm}$
3. $11\text{dBm} + 10\log (23.07) = 24.63 > 24\text{dBm}$
4. $11\text{dBm} + 10\log (24.32) = 24.86 > 24\text{dBm}$
5. $11\text{dBm} + 10\log (25.10) = 25.00 > 24\text{dBm}$
6. $11\text{dBm} + 10\log (25.50) = 25.07 > 24\text{dBm}$



802.11n (20MHz)

CHANNEL	CHANNEL FREQUENCY (MHz)	AVERAGE POWER (mW)	AVERAGE POWER (dBm)	POWER LIMIT (dBm)	PASS/FAIL
36	5180	16.827	12.26	17	PASS
40	5200	20.137	13.04	17	PASS
48	5240	15.922	12.02	17	PASS
52	5260	15.922	12.02	24	PASS
60	5300	15.959	12.03	24	PASS
64	5320	15.885	12.01	24	PASS
100	5500	16.711	12.23	24	PASS
116	5580	15.453	11.89	24	PASS
140	5700	15.922	12.02	24	PASS

NOTE:

For 5180~5240MHz:

- 1. $4\text{dBm} + 10\log (24.12) = 17.82 > 17\text{dBm}$
- 2. $4\text{dBm} + 10\log (24.48) = 17.89 > 17\text{dBm}$
- 3. $4\text{dBm} + 10\log (23.69) = 17.75 > 17\text{dBm}$

For 5260~5700MHz:

- 1. $11\text{dBm} + 10\log (24.46) = 24.88 > 24\text{dBm}$
- 2. $11\text{dBm} + 10\log (23.73) = 24.75 > 24\text{dBm}$
- 3. $11\text{dBm} + 10\log (24.23) = 24.84 > 24\text{dBm}$
- 4. $11\text{dBm} + 10\log (28.13) = 25.49 > 24\text{dBm}$
- 5. $11\text{dBm} + 10\log (24.26) = 24.85 > 24\text{dBm}$
- 6. $11\text{dBm} + 10\log (23.77) = 24.76 > 24\text{dBm}$



802.11n (40MHz)

CHANNEL	CHANNEL FREQUENCY (MHz)	AVERAGE POWER (mW)	AVERAGE POWER (dBm)	POWER LIMIT (dBm)	PASS/FAIL
38	5190	17.061	12.32	17	PASS
46	5230	16.634	12.21	17	PASS
54	5270	16.368	12.14	24	PASS
62	5310	16.904	12.28	24	PASS
102	5510	16.293	12.12	24	PASS
110	5550	16.827	12.26	24	PASS
134	5670	16.520	12.18	24	PASS

NOTE:

For 5190~5270MHz:

1. $4\text{dBm} + 10\log (66.07) = 22.20 > 17\text{dBm}$
2. $4\text{dBm} + 10\log (59.41) = 21.74 > 17\text{dBm}$

For 5310~5670MHz:

1. $11\text{dBm} + 10\log (65.96) = 29.19 > 24\text{dBm}$
2. $11\text{dBm} + 10\log (56.19) = 28.50 > 24\text{dBm}$
3. $11\text{dBm} + 10\log (72.05) = 29.58 > 24\text{dBm}$
4. $11\text{dBm} + 10\log (76.09) = 29.81 > 24\text{dBm}$
5. $11\text{dBm} + 10\log (68.31) = 29.34 > 24\text{dBm}$

**26dB BANDWIDTH:****802.11a**

CHANNEL	CHANNEL FREQUENCY (MHz)	26dBc BANDWIDTH (MHz)	PASS / FAIL
36	5180	23.59	PASS
40	5200	24.06	PASS
48	5240	24.16	PASS
52	5260	23.91	PASS
60	5300	23.83	PASS
64	5320	23.07	PASS
100	5500	24.32	PASS
116	5580	25.10	PASS
140	5700	25.50	PASS

802.11n (20MHz)

CHANNEL	CHANNEL FREQUENCY (MHz)	26dBc BANDWIDTH (MHz)	PASS / FAIL
36	5180	24.12	PASS
40	5200	24.48	PASS
48	5240	23.69	PASS
52	5260	24.46	PASS
60	5300	23.73	PASS
64	5320	24.23	PASS
100	5500	28.13	PASS
116	5580	24.26	PASS
140	5700	23.77	PASS

802.11n (40MHz)

CHANNEL	CHANNEL FREQUENCY (MHz)	26dBc BANDWIDTH (MHz)	PASS / FAIL
38	5190	66.07	PASS
46	5230	59.41	PASS
54	5270	65.96	PASS
62	5310	56.19	PASS
102	5510	72.05	PASS
110	5550	76.09	PASS
134	5670	68.31	PASS



ADT

SPECTRUM PLOT OF WORST VALUE

802.11a

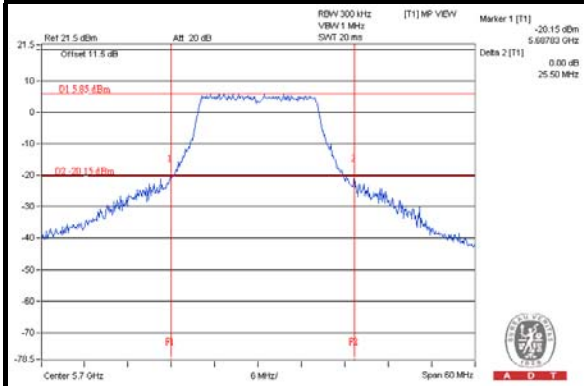

802.11n (20MHz)

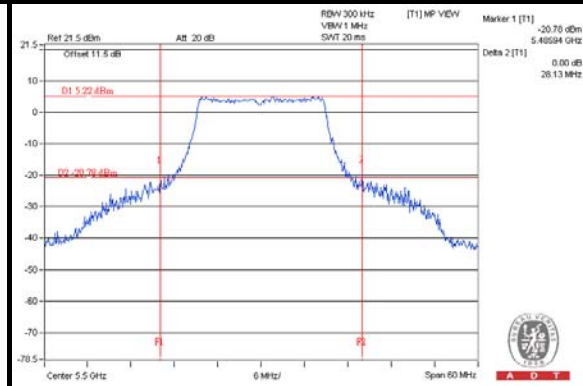

802.11n (40MHz)

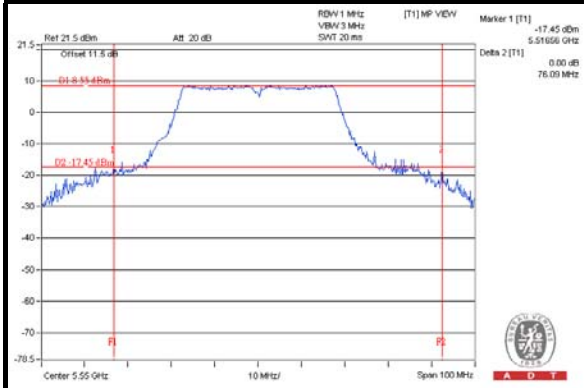

4.4 PEAK POWER SPECTRAL DENSITY MEASUREMENT

4.4.1 LIMITS OF PEAK POWER SPECTRAL DENSITY MEASUREMENT

FREQUENCY BAND	LIMIT
5.150 ~ 5.250GHz	4dBm
5.250 ~ 5.350GHz	11dBm
5.470 ~ 5.725GHz	11dBm

4.4.2 TEST SETUP

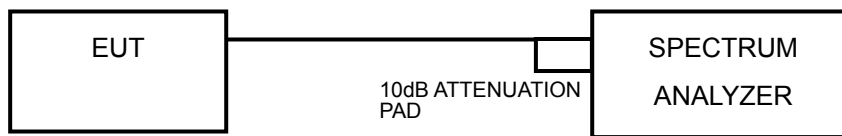

4.4.3 TEST INSTRUMENTS

Refer to section 4.1.3 to get information of above instrument.

4.4.4 TEST PROCEDURES

802.11a:

Using method SA-1

- 1) Set span to encompass the entire emission bandwidth (EBW) of the signal.
- 2) Set RBW = 30 KHz, Set VBW \geq 1 MHz, Detector = RMS
- 3) Set Channel power measure = 1MHz
- 4) Sweep time = auto, trigger set to "free run".
- 5) Trace average at least 100 traces in power averaging mode.
- 6) Record the max value

802.11n (20MHz) and 802.11n (40MHz):

Using method SA-2

- 1) Set span to encompass the entire emission bandwidth (EBW) of the signal.
- 2) Set RBW = 30 KHz, Set VBW \geq 1 MHz, Detector = RMS
- 3) Set Channel power measure = 1MHz
- 4) Sweep time = auto, trigger set to "free run".
- 5) Trace average at least 100 traces in power averaging mode.
- 6) Record the max value and add $10 \log (1/\text{duty cycle})$

4.4.5 DEVIATION FROM TEST STANDARD

No deviation.

4.4.6 EUT OPERATING CONDITIONS

Same as 4.3.6.



4.4.7 TEST RESULTS

802.11a

CHANNEL	FREQUENCY (MHz)	PSD (dBm)	MAXIMUM LIMIT (dBm)	PASS/FAIL
36	5180	1.81	4	PASS
40	5200	1.52	4	PASS
48	5240	1.97	4	PASS
52	5260	1.75	11	PASS
60	5300	1.55	11	PASS
64	5320	1.61	11	PASS
100	5500	1.74	11	PASS
116	5580	1.87	11	PASS
140	5700	2.05	11	PASS

802.11n (20MHz)

CHANNEL	FREQUENCY (MHz)	PSD W/O DUTY FACTOR (dBm)	DUTY FACTOR	PSD WITH DUTY FACTOR (dBm)	MAXIMUM LIMIT (dBm)	PASS/FAIL
36	5180	1.20	0.59	1.79	4	PASS
40	5200	1.37	0.59	1.96	4	PASS
48	5240	1.58	0.59	2.17	4	PASS
52	5260	1.31	0.59	1.90	11	PASS
60	5300	1.25	0.59	1.84	11	PASS
64	5320	1.23	0.59	1.82	11	PASS
100	5500	1.35	0.59	1.94	11	PASS
116	5580	1.31	0.59	1.90	11	PASS
140	5700	1.89	0.59	2.48	11	PASS

NOTE: Refer to section 3.3 for duty cycle spectrum plot.

802.11n (40MHz)

CHANNEL	FREQUENCY (MHz)	PSD W/O DUTY FACTOR (dBm)	DUTY FACTOR	PSD WITH DUTY FACTOR (dBm)	MAXIMUM LIMIT (dBm)	PASS/FAIL
38	5190	-1.40	0.13	-1.27	4	PASS
46	5230	-1.58	0.13	-1.45	4	PASS
54	5270	-1.41	0.13	-1.28	11	PASS
62	5310	-1.63	0.13	-1.50	11	PASS
102	5510	-1.59	0.13	-1.46	11	PASS
110	5550	-1.00	0.13	-0.87	11	PASS
134	5670	-1.54	0.13	-1.41	11	PASS

NOTE: Refer to section 3.3 for duty cycle spectrum plot.



A D T

SPECTRUM PLOT OF WORST VALUE

802.11a

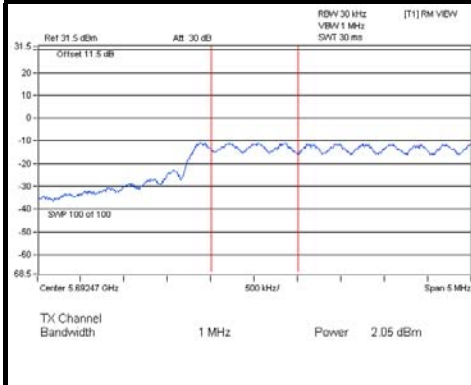

802.11n (20MHz)

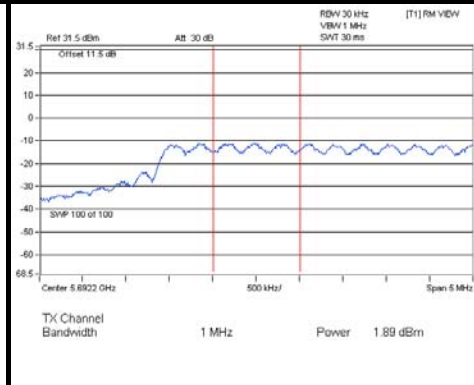

802.11n (40MHz)

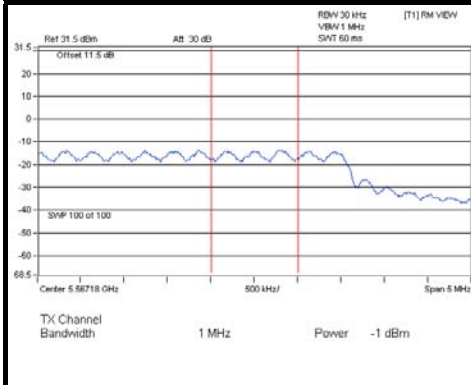

4.5 PEAK POWER EXCURSION MEASUREMENT

4.5.1 LIMITS OF PEAK POWER EXCURSION MEASUREMENT

Shall not exceed 13 dB.

4.5.2 TEST SETUP



4.5.3 TEST INSTRUMENTS

Refer to section 4.1.3 to get information of above instrument.

4.5.4 TEST PROCEDURE

- 1) Set RBW = 1 MHz, VBW \geq 3 MHz, Detector = peak.
- 2) Trace mode = max-hold. Allow the sweeps to continue until the trace stabilizes.
- 3) Use the peak search function to find the peak of the spectrum.
- 4) Measure the PPSD.
- 5) Compute the ratio of the maximum of the peak-max-hold spectrum to the PPSD. Find the worst channel and modulation mode as above test procedure, and follow KDB 789033 D01 General UNII Test Procedures v01r03 and repeat step 1 to 5 for final testing of each modulation mode on a single channel (all modulation types) in a single operating band to compliance with the peak excursion requirement.

4.5.5 DEVIATION FROM TEST STANDARD

No deviation.

4.5.6 EUT OPERATING CONDITIONS

Same as 4.2.6



A D T

4.5.7 TEST RESULTS

MODULATION MODE	MODULATION TYPE	CHAN. FREQ. (MHz)	PEAK VALUE (dBm)	PPSD WITHOUT DUTY FACTOR (dBm)	PPSD WITH DUTY FACTOR (dBm)	PEAK EXCURSION (dB)	LIMIT (dB)	PASS /FAIL
802.11a	BPSK	5700	11.80	2.05	2.05	9.75	13	PASS
	QPSK		11.73	1.74	2.13	9.60	13	PASS
	16QAM		12.01	1.83	2.57	9.44	13	PASS
	64QAM		11.65	1.75	3.08	8.57	13	PASS
802.11n (20MHz)	BPSK	5700	12.15	1.89	2.48	9.67	13	PASS
	QPSK		11.73	1.77	3.19	8.54	13	PASS
	16QAM		12.01	1.81	4.13	7.88	13	PASS
	64QAM		11.65	1.77	4.54	7.11	13	PASS
802.11n (40MHz)	BPSK	5670	9.84	-1.54	-1.41	11.25	13	PASS
	QPSK		9.66	-1.64	0.17	9.49	13	PASS
	16QAM		9.94	-1.74	0.86	9.08	13	PASS
	64QAM		9.85	-1.72	1.66	8.19	13	PASS

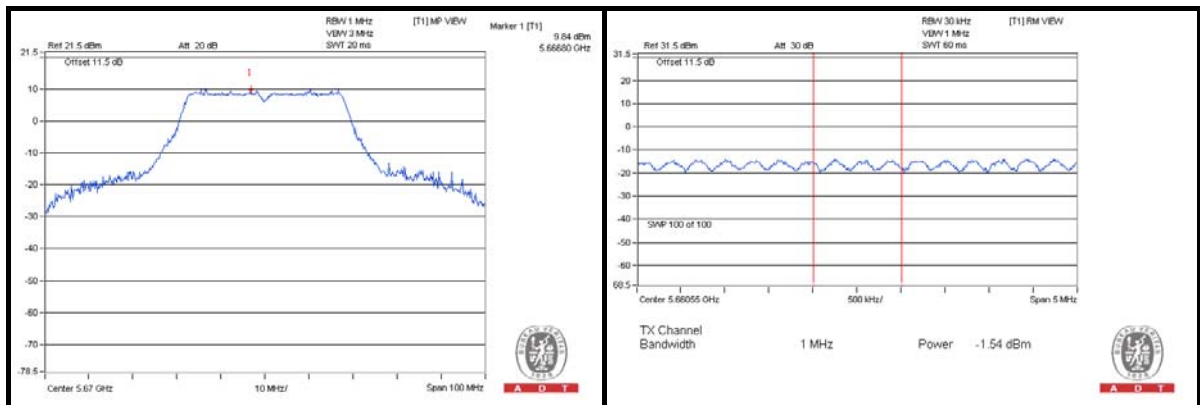

4.6 FREQUENCY STABILITY

4.6.1 LIMITS OF FREQUENCY STABILITY MEASUREMENT

The frequency of the carrier signal shall be maintained within band of operation

4.6.2 TEST SETUP

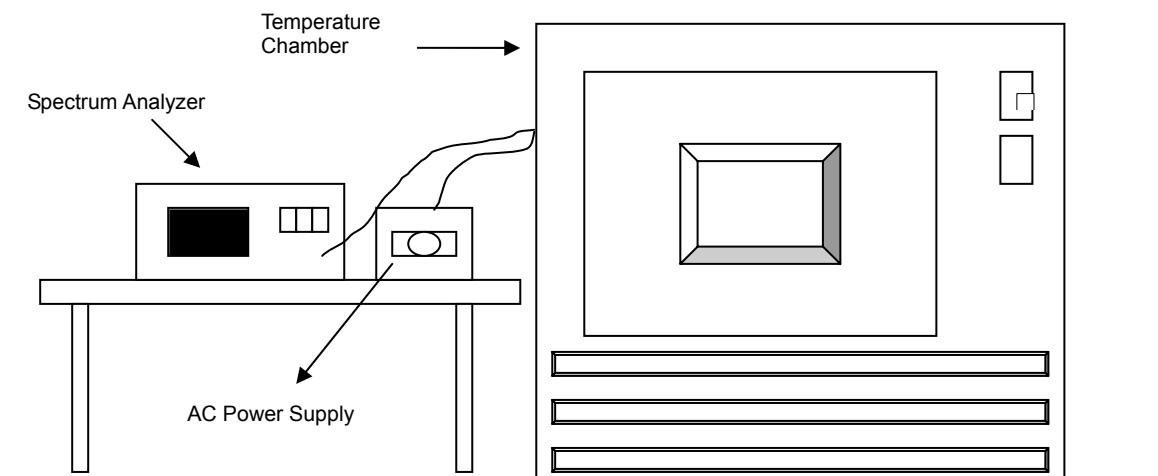

4.6.3 TEST INSTRUMENTS

Refer to section 4.1.3 to get information of above instrument.

4.6.4 TEST PROCEDURE

- a. The EUT was placed inside the environmental test chamber and powered by nominal AC voltage.
- b. Turn the EUT on and couple its output to a spectrum analyzer.
- c. Turn the EUT off and set the chamber to the highest temperature specified.
- d. Allow sufficient time (approximately 30 min) for the temperature of the chamber to stabilize, turn the EUT on and measure the operating frequency after 2, 5, and 10 minutes.
- e. Repeat step 2 and 3 with the temperature chamber set to the lowest temperature.
- f. The test chamber was allowed to stabilize at +20 degree C for a minimum of 30 minutes. The supply voltage was then adjusted on the EUT from 85% to 115% and the frequency record.

4.6.5 DEVIATION FROM TEST STANDARD

No deviation.

4.6.6 EUT OPERATING CONDITION

Set the EUT transmit at un-modulation mode to test frequency stability.



4.6.7 TEST RESULTS

FREQUENCY STABILITY VERSUS TEMP.									
OPERATING FREQUENCY: 5320MHz									
TEMP. (°C)	POWER SUPPLY (Vac)	0 MINUTE		2 MINUTE		5 MINUTE		10 MINUTE	
		Measured Frequency (MHz)	Frequency Drift (%)	Measured Frequency (MHz)	Frequency Drift (%)	Measured Frequency (MHz)	Frequency Drift (%)	Measured Frequency (MHz)	Frequency Drift (%)
50	120	5320.0063	0.00012	5320.0079	0.00015	5320.0086	0.00016	5320.0099	0.00019
40	120	5320.0027	0.00005	5319.9935	-0.00012	5319.9956	-0.00008	5320.0033	0.00006
30	120	5320.0247	0.00046	5320.019	0.00036	5320.025	0.00047	5320.0224	0.00042
20	120	5320.0022	0.00004	5319.9997	-0.00001	5319.9932	-0.00013	5319.9997	-0.00001
10	120	5320.0194	0.00036	5320.0198	0.00037	5320.0159	0.00030	5320.0246	0.00046
0	120	5320.0033	0.00006	5320.0079	0.00015	5320.0021	0.00004	5320.0101	0.00019
-10	120	5319.9997	-0.00001	5320.0018	0.00003	5319.9968	-0.00006	5319.9982	-0.00003
-20	120	5320.0044	0.00008	5320.0103	0.00019	5320.0081	0.00015	5320.0053	0.00010
-30	120	5320.0058	0.00011	5320.0054	0.00010	5320.0042	0.00008	5320.0014	0.00003

FREQUENCY STABILITY VERSUS VOLTAGE									
OPERATING FREQUENCY: 5320MHz									
TEMP. (°C)	POWER SUPPLY (Vac)	0 MINUTE		2 MINUTE		5 MINUTE		10 MINUTE	
		Measured Frequency (MHz)	Frequency Drift (%)	Measured Frequency (MHz)	Frequency Drift (%)	Measured Frequency (MHz)	Frequency Drift (%)	Measured Frequency (MHz)	Frequency Drift (%)
20	138	5320.0019	0.00004	5319.9994	-0.00001	5319.9927	-0.00014	5319.9999	0.00000
	120	5320.0022	0.00004	5319.9997	-0.00001	5319.9932	-0.00013	5319.9997	-0.00001
	102	5320.0015	0.00003	5319.9997	-0.00001	5319.9932	-0.00013	5320.0001	0.00000

5. PHOTOGRAPHS OF THE TEST CONFIGURATION

Please refer to the attached file (Test Setup Photo).



6. INFORMATION ON THE TESTING LABORATORIES

We, Bureau Veritas Consumer Products Services (H.K.) Ltd., Taoyuan Branch, were founded in 1988 to provide our best service in EMC, Radio, Telecom and Safety consultation. Our laboratories are accredited and approved according to ISO/IEC 17025.

If you have any comments, please feel free to contact us at the following:

Linko EMC/RF Lab:

Tel: 886-2-26052180

Fax: 886-2-26051924

Hsin Chu EMC/RF Lab:

Tel: 886-3-5935343

Fax: 886-3-5935342

Hwa Ya EMC/RF/Safety Telecom Lab:

Tel: 886-3-3183232

Fax: 886-3-3270892

Email: service.adt@tw.bureauveritas.com

Web Site: www.bureauveritas-adt.com

The address and road map of all our labs can be found in our web site also.

7. APPENDIX A – MODIFICATIONS RECORDERS FOR ENGINEERING CHANGES TO THE EUT BY THE LAB

No modifications were made to the EUT by the lab during the test.

---END---