

**FCC 47 CFR PART 15 SUBPART C &
INDUSTRY CANADA RSS-247****TEST REPORT****For****Notebook Computer****FCC Model:**

Satellite CL1*****-C*****(* means 0-9; a-z; A-Z; / ; - ; or blank),
Satellite L1*****-C*****(* means 0-9; a-z; A-Z; / ; - ; or blank),
Satellite Radius 11 CL1*****-C*****(* means 0-9; a-z; A-Z; / ; - ; or blank),
Satellite Radius 11 L1*****-C*****(* means 0-9; a-z; A-Z; / ; - ; or blank),
dynabook N31, dynabook NB31, dynabook N41, dynabookNB41, dynabook N61,
dynabook NB61

IC Model:**Satellite L10W-C****Trade Name: TOSHIBA***Issued to***Pegatron Corporation****5F, NO. 76, LIGONG ST., BEITOU DISTRICT, TAIPEI CITY 112, TAIWAN (R.O.C.)***Issued by***Compliance Certification Services Inc.****No.11, Wugong 6th Rd., Wugu Dist.,****New Taipei City 24891, Taiwan. (R.O.C.)****<http://www.ccsrf.com>****service@ccsrf.com****Issued Date: August 13, 2015**

Note: This report shall not be reproduced except in full, without the written approval of Compliance Certification Services Inc. This document may be altered or revised by Compliance Certification Services Inc. personnel only, and shall be noted in the revision section of the document.



Revision History

Rev.	Issue Date	Revisions	Effect Page	Revised By
00	August 13, 2015	Initial Issue	ALL	Becca Chen
01	August 27, 2015	1. Added Loop Antenna. 2. Added remarks and narrative.	P.10, P.43	Becca Chen

TABLE OF CONTENTS

1. TEST RESULT CERTIFICATION	4
2. EUT DESCRIPTION	5
3. TEST METHODOLOGY	7
3.1 EUT CONFIGURATION	7
3.2 EUT EXERCISE	7
3.3 GENERAL TEST PROCEDURES	7
3.4 FCC PART 15.205 RESTRICTED BANDS OF OPERATIONS	8
3.5 DESCRIPTION OF TEST MODES	9
4 INSTRUMENT CALIBRATION	10
4.1 MEASURING INSTRUMENT CALIBRATION	10
4.2 MEASUREMENT EQUIPMENT USED	10
4.3 MEASUREMENT UNCERTAINTY	11
5 FACILITIES AND ACCREDITATIONS	12
5.1 FACILITIES	12
5.2 EQUIPMENT	12
5.3 TABLE OF ACCREDITATIONS AND LISTINGS	13
6 SETUP OF EQUIPMENT UNDER TEST	14
6.1 SETUP CONFIGURATION OF EUT	14
6.2 SUPPORT EQUIPMENT	14
7 FCC PART 15.247 REQUIREMENTS & RSS-247 REQUIREMENTS	15
7.1 99% BANDWIDTH	15
7.2 6DB BANDWIDTH	18
7.3 PEAK POWER	22
7.4 AVERAGE POWER	23
7.5 BAND EDGES MEASUREMENT	24
7.6 PEAK POWER SPECTRAL DENSITY	32
7.7 SPURIOUS EMISSIONS	36
7.8 RADIATED EMISSIONS	40
7.9 POWERLINE CONDUCTED EMISSIONS	55
APPENDIX I PHOTOGRAPHS OF TEST SETUP	58

1. TEST RESULT CERTIFICATION

Applicant: Pegatron Corporation
 5F, NO. 76, LIGONG ST., BEITOU DISTRICT, TAIPEI CITY 112,
 TAIWAN (R.O.C.)

Manufacturer: Toshiba Corporation
 1-1, Shibaura 1-Chome, Minato-Ku, Tokyo, 105-8001, Japan

Equipment Under Test: Notebook Computer

Trade Name: TOSHIBA

FCC Model: Satellite CL1*****-C*****(* means 0-9; a-z; A-Z; / ; - ; or blank),
 Satellite L1*****-C*****(* means 0-9; a-z; A-Z; / ; - ; or blank),
 Satellite Radius 11 CL1*****-C*****(* means 0-9; a-z; A-Z; / ; - ; or
 blank),
 Satellite Radius 11 L1*****-C*****(* means 0-9; a-z; A-Z; / ; - ; or
 blank),
 dynabook N31, dynabook NB31, dynabook N41, dynabookNB41,
 dynabook N61, dynabook NB61

IC Model: Satellite L10W-C

Date of Test: July 21 ~ August 5, 2015

APPLICABLE STANDARDS	
STANDARD	TEST RESULT
FCC 47 CFR Part 15 Subpart C Industry Canada RSS-247 Issue 1	No non-compliance noted
Deviation from Applicable Standard	
N/A	

We hereby certify that:

The above equipment was tested by Compliance Certification Services Inc. The test data, data evaluation, test procedures, and equipment configurations shown in this report were made in accordance with the procedures given in ANSI C63.10: 2013 for IC, ANSI C63.10: 2009 for FCC and the energy emitted by the sample EUT tested as described in this report is in compliance with the requirements set forth in the above standards.

The test results of this report relate only to the tested sample EUT identified in this report.

Approved by:



Miller Lee
 Manager
 Compliance Certification Services Inc.

Reviewed by:



Angel Cheng
 Section Manager
 Compliance Certification Services Inc.

2. EUT DESCRIPTION

Product	Notebook Computer		
Trade Name	TOSHIBA		
FCC Model Number	Satellite CL1*****-C*****(* means 0-9; a-z; A-Z; / ; - ; or blank), Satellite L1*****-C*****(* means 0-9; a-z; A-Z; / ; - ; or blank), Satellite Radius 11 CL1*****-C*****(* means 0-9; a-z; A-Z; / ; - ; or blank), Satellite Radius 11 L1*****-C*****(* means 0-9; a-z; A-Z; / ; - ; or blank), dynabook N31, dynabook NB31, dynabook N41, dynabookNB41, dynabook N61, dynabook NB61		
IC Model Number	Satellite L10W-C		
Model Discrepancy	All the above models are identical except for the designation of model numbers. The suffix of "*" (* means 0-9; a-z; A-Z; / ; - ; or blank) on model number is just for marketing purpose only.		
Received Date	July 8, 2015		
WLAN Manufacturer	Broadcom	Model	BCM943142Y
EUT Power Rating	1. 19Vdc from Adaptor 2. Powered from Battery Toshiba (LG) / PA5209U-1BRS: 7.2V, 28Wh (3684mAh) Toshiba (PANASONIC) / PA5209U-1BRS: 3.6V, 29Wh (4090mAh)		
Power Adaptor Power Rating / Manufacturer	Toshiba (Vendor: Liteon) / PA3822U-1ACA I/P: 100-240Vac, 50-60Hz, 1.3A O/P: 19Vdc, 2.37A		
	Toshiba (Vendor: Liteon) / PA3822E-1AC3 I/P: 100-240Vac, 50-60Hz, 1.3A O/P: 19Vdc, 2.37A		
	Toshiba (Vendor: Delta) / PA3822U-1ACA I/P: 100-240Vac, 50-60Hz, 1.2A O/P: 19Vdc, 2.37A		
	Toshiba (Vendor: Delta) / PA3822E-1AC3 I/P: 100-240Vac, 50-60Hz, 1.2A O/P: 19Vdc, 2.37A		
	Toshiba (Vendor: Chicony) / PA3822U-1ACA I/P: 100-240Vac, 50-60Hz, 1.3A O/P: 19Vdc, 2.37A		
	Toshiba (Vendor: Chicony) / PA3822E-1AC3 I/P: 100-240Vac, 50-60Hz, 1.3A O/P: 19Vdc, 2.37A		
	Toshiba (Vendor: Liteon) / PA5177U-1ACA I/P: 100-240Vac, 50-60Hz, 1.3A O/P: 19Vdc, 2.37A		
	Toshiba (Vendor: Liteon) / PA5177E-1AC3 I/P: 100-240Vac, 50-60Hz, 1.3A O/P: 19Vdc, 2.37A		
	Toshiba (Vendor: Delta) / PA5177U-1ACA I/P: 100-240Vac, 50/60Hz, 1.2A		

	O/P: 19Vdc, 2.37A
	Toshiba (Vendor: Delta) / PA5177E-1AC3 I/P: 100-240Vac, 50/60Hz, 1.2A O/P: 19Vdc, 2.37A
	Toshiba (Vendor: Chicony) / PA5177U-1ACA I/P: 100-240Vac, 50-60Hz, 1.3A O/P: 19Vdc, 2.37A
	Toshiba (Vendor: Chicony) / PA5177E-1AC3 I/P: 100-240Vac, 50-60Hz, 1.3A O/P: 19Vdc, 2.37A
Frequency Range	2402MHz ~ 2480MHz
Transmit Power	-0.83 dBm
Modulation Technique	BT 4.0 LE mode, GFSK (1Mbps)
Number of Channels	40 Channels
Antenna Designation	PIFA Antenna Yageo / ANTA0TP09161WLAN1(Main) / 1.53 dBi Yageo / ANTA0TP09161WLAN2 (Aux)/ 1.31 dBi ACON / APP6Y-700149 (Main) / -0.88 dBi ACON / APP6Y-700150 (Aux) / 1.21 dBi INPAQ / WA-P-LB-02-288 (Main) / 0.56 dBi INPAQ / WA-P-LB-01-137(Aux) / 0.09 dBi

Remark:

1. The sample selected for test was engineering sample that approximated to production product and was provided by manufacturer.
2. This submittal(s) (test report) is intended for FCC&IC ID: **VUI-MORPHEUS43142** & **7582A-MORPHEUS43142** filing to comply with FCC Part 15C, Section 15.207, 15.209 and IC RSS-247 & RSS-GEN.

3. TEST METHODOLOGY

The tests documented in this report were performed in accordance with ANSI C63.10: 2013 and FCC CFR 47 Part 15.207, 15.209, 15.247.

The tests documented in this report were performed in accordance with IC RSS-247, IC RSS-Gen and ANSI C63.10:2013.

This submittal(s) (test report) is intended for IC Certification with Industry Canada RSS-247.

3.1 EUT CONFIGURATION

The EUT configuration for testing is installed on RF field strength measurement to meet the Commissions requirement and operating in a manner that intends to maximize its emission characteristics in a continuous normal application.

3.2 EUT EXERCISE

The EUT was operated in the engineering mode to fix the TX frequency that was for the purpose of the measurements.

According to its specifications, the EUT must comply with the requirements of the Section 15.207, 15.209 and 15.247 under the FCC Rules Part 15 Subpart C and RSS-247 Annex 1.

3.3 GENERAL TEST PROCEDURES

Conducted Emissions

The EUT is placed on the turntable, which is 0.8 m above ground plane. According to the requirements in ANSI C63.10: 2013 for IC, ANSI C63.10: 2013 for FCC Conducted emissions from the EUT measured in the frequency range between 0.15 MHz and 30MHz using CISPR Quasi-peak and average detector modes.

Radiated Emissions

The EUT is placed on a turn table, which is 1.5 m above ground plane. The turntable shall rotate 360 degrees to determine the position of maximum emission level. EUT is set 3m away from the receiving antenna, which varied from 1m to 4m to find out the highest emission. And also, each emission was to be maximized by changing the polarization of receiving antenna both horizontal and vertical. In order to find out the maximum emissions, exploratory radiated emission measurements were made according to the requirements in ANSI C63.10: 2013 for IC, ANSI C63.10: 2013 for FCC.

3.4 FCC PART 15.205 RESTRICTED BANDS OF OPERATIONS

(a) Except as shown in paragraph (d) of this section, only spurious emissions are permitted in any of the frequency bands listed below:

MHz	MHz	MHz	GHz
0.090 - 0.110	16.42 - 16.423	399.9 - 410	4.5 - 5.15
¹ 0.495 - 0.505	16.69475 - 16.69525	608 - 614	5.35 - 5.46
2.1735 - 2.1905	16.80425 - 16.80475	960 - 1240	7.25 - 7.75
4.125 - 4.128	25.5 - 25.67	1300 - 1427	8.025 - 8.5
4.17725 - 4.17775	37.5 - 38.25	1435 - 1626.5	9.0 - 9.2
4.20725 - 4.20775	73 - 74.6	1645.5 - 1646.5	9.3 - 9.5
6.215 - 6.218	74.8 - 75.2	1660 - 1710	10.6 - 12.7
6.26775 - 6.26825	108 - 121.94	1718.8 - 1722.2	13.25 - 13.4
6.31175 - 6.31225	123 - 138	2200 - 2300	14.47 - 14.5
8.291 - 8.294	149.9 - 150.05	2310 - 2390	15.35 - 16.2
8.362 - 8.366	156.52475 -	2483.5 - 2500	17.7 - 21.4
8.37625 - 8.38675	156.52525	2655 - 2900	22.01 - 23.12
8.41425 - 8.41475	156.7 - 156.9	3260 - 3267	23.6 - 24.0
12.29 - 12.293	162.0125 - 167.17	3332 - 3339	31.2 - 31.8
12.51975 - 12.52025	167.72 - 173.2	3345.8 - 3358	36.43 - 36.5
12.57675 - 12.57725	240 - 285	3600 - 4400	(²)
13.36 - 13.41	322 - 335.4		

¹ Until February 1, 1999, this restricted band shall be 0.490-0.510 MHz.

² Above 38.6

(b) Except as provided in paragraphs (d) and (e), the field strength of emissions appearing within these frequency bands shall not exceed the limits shown in Section 15.209. At frequencies equal to or less than 1000 MHz, compliance with the limits in Section 15.209 shall be demonstrated using measurement instrumentation employing a CISPR quasi-peak detector. Above 1000 MHz, compliance with the emission limits in Section 15.209 shall be demonstrated based on the average value of the measured emissions. The provisions in Section 15.35 apply to these measurements.

3.5 DESCRIPTION OF TEST MODES

The EUT (model: Satellite L10W-C) had been tested under operating condition.

Software used to control the EUT for staying in continuous transmitting mode was programmed.

After verification, all tests were carried out with the worst case test modes as shown below except radiated spurious emission below 1GHz and power line conducted emissions below 30MHz, which worst case was in normal link mode only.

BT 4.0

Tested Channel	Frequency (MHz)
Low	2402
Mid	2440
High	2480

The field strength of spurious emission was measured in the following position: The EUT has Notebook mode, Flat mode, and Tent mode, Stand mode, Tablet X, Y and Z axis modes. The worst emission was found in Flat mode and the worst case was recorded.

4 INSTRUMENT CALIBRATION

4.1 MEASURING INSTRUMENT CALIBRATION

The measuring equipment, which was utilized in performing the tests documented herein, has been calibrated in accordance with the manufacturer's recommendations for utilizing calibration equipment, which is traceable to recognized national standards.

4.2 MEASUREMENT EQUIPMENT USED

Equipment Used for Emissions Measurement

Remark: Each piece of equipment is scheduled for calibration once a year and Loop Antenna is scheduled for calibration once three years.

Conducted Emissions Test Site				
Name of Equipment	Manufacturer	Model	Serial Number	Calibration Due
Spectrum Analyzer	Agilent	E4446A	US42510252	11/23/2015
Thermostatic/Hrgrosatic Chamber	TAICHY	MHG-150LF	930619	10/07/2015
AC Power Source	EXTECH	6205	1140845	N.C.R
DC Power Supply	ABM	8301HD	D011531	N.C.R
Power Meter	Anritsu	ML2495A	1012009	06/07/2016
Power Sensor	Anritsu	MA2411A	0917072	06/08/2016
Spectrum Analyzer	ROHDE&SCHWARZ	FSV40	101073	07/19/2016

Wugu 966 Chamber A				
Name of Equipment	Manufacturer	Model	Serial Number	Calibration Due
Spectrum Analyzer	Agilent	E4446A	US42510268	09/18/2015
EMI Test Receiver	R&S	ESCI	100064	06/04/2016
Bilog Antenna	Sunol Sciences	JB3	A030105	08/19/2015
Horn Antenna	EMCO	3117	00055165	01/26/2016
Horn Antenna	EMCO	3116	26370	12/25/2015
Turn Table	CCS	CC-T-1F	N/A	N.C.R
Antenna Tower	CCS	CC-A-1F	N/A	N.C.R
Controller	CCS	CC-C-1F	N/A	N.C.R
Pre-Amplifier	MITEQ	1652-3000	1490939	08/09/2016
Pre-Amplifier	EMC	EMC 01265	4035	06/04/2016
Pre-Amplifier	MITEQ	AMF-6F-260400-40-8P	985646	12/25/2015
Coaxial Cable	Huber+Suhner	102	29212/2	12/25/2015
Coaxial Cable	Huber+Suhner	102	29406/2	12/25/2015
Loop Antenna	COM-POWER	AL-130	121051	01/26/2016
Test S/W	EZ-EMC (CCS-3A1RE)			

Conducted Emission Room #B				
Name of Equipment	Manufacturer	Model	Serial Number	Calibration Due
EMI Test Receiver	R&S	ESCI	101073	09/18/2015
LISN	R&S	ENV216	101054	06/06/2016
LISN	SCHWARZBECK	NSLK 8127	8127-541	11/25/2015
Capacitive Voltage Probe	FCC	F-CVP-1	100185	03/12/2016
Test S/W	CCS-3A1-CE			

4.3 MEASUREMENT UNCERTAINTY

PARAMETER	UNCERTAINTY
Powerline Conducted Emission	+/-1.2575
3M Semi Anechoic Chamber / 30M~200M	+/- 4.0138
3M Semi Anechoic Chamber / 200M~1000M	+/- 3.9483
3M Semi Anechoic Chamber / 1G~8G	+/- 2.5975
3M Semi Anechoic Chamber / 8G~18G	+/- 2.6112
3M Semi Anechoic Chamber / 18G~26G	+/- 2.7389
3M Semi Anechoic Chamber / 26G~40G	+/- 2.9683

Remark: This uncertainty represents an expanded uncertainty expressed at approximately the 95% confidence level using a coverage factor of $k=2$.

5 FACILITIES AND ACCREDITATIONS

5.1 FACILITIES

All measurement facilities used to collect the measurement data are located at

- No.139, Wugong Rd., Wugu Dist., New Taipei City 24891, Taiwan (R.O.C.)
Tel: 886-2-2298-4086 / Fax: 886-2-2298-1470
- No.11, Wugong 6th Rd., Wugu Dist., New Taipei City 24891, Taiwan. (R.O.C.)
Tel: 886-2-2299-9720 / Fax: 886-2-2298-4045
- No.81-1, Lane 210, Bade 2nd Rd., Lujhu Township, Taoyuan County 33841, TAIWAN,
R.O.C.
Tel: 886-3-324-0332 / Fax: 886-3-324-5235

The sites are constructed in conformance with the requirements of ANSI C63.7, ANSI C63.10: 2013 for IC, ANSI C63.10: 2009 for FCC and CISPR Publication 22.

5.2 EQUIPMENT



Radiated emissions are measured with one or more of the following types of linearly polarized antennas: tuned dipole, bucolical, log periodic, bi-log, ridged waveguide, horn and/or Loop. Spectrum analyzers with pre-selectors and quasi-peak detectors are used to perform radiated measurements.

Conducted emissions are measured with Line Impedance Stabilization Networks and EMI Test Receivers.

Calibrated wideband preamplifiers, coaxial cables, and coaxial attenuators are also used for making measurements.

All receiving equipment conforms to CISPR Publication 16-1, "Radio Interference Measuring Apparatus and Measurement Methods."

5.3 TABLE OF ACCREDITATIONS AND LISTINGS

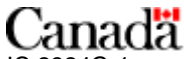
Country	Agency	Scope of Accreditation	Logo
USA	FCC	3M Semi Anechoic Chamber (FCC MRA: TW1039) to perform FCC Part 15 measurements	 FCC MRA: TW1039
Taiwan	TAF	LP0002, RTTE01, FCC Method-47 CFR Part 15 Subpart C, D, E, RSS-247, RSS-310 IDA TS SRD, AS/NZS 4268, AS/NZS 4771, TS 12.1 & 12.2, ETSI EN 300 440-1, ETSI EN 300 440-2, ETSI EN 300 328, ETSI EN 300 220-1, ETSI EN 300 220-2, ETSI EN 301 893, ETSI EN 301 489-1/3/7/17 FCC OET Bulletin 65 + Supplement C, EN 50360, EN 50361, EN 50371, RSS 102, EN 50383, EN 50385, EN 50392, IEC 62209, CNS 14958-1, CNS 14959 FCC Method -47 CFR Part 15 Subpart B IEC / EN 61000-3-2, IEC / EN 61000-3-3, IEC / EN 61000-4-2/3/4/5/6/8/11	
Canada	Industry Canada	3M Semi Anechoic Chamber (IC 2324G-1 / IC 2324G-2) to perform	 IC 2324G-1 IC 2324G-2

* No part of this report may be used to claim or imply product endorsement by A2LA or any agency of the US Government.

6 SETUP OF EQUIPMENT UNDER TEST

6.1 SETUP CONFIGURATION OF EUT

See test photographs attached in Appendix I for the actual connections between EUT and support equipment.

6.2 SUPPORT EQUIPMENT

No.	Device Type	Brand	Model	Series No.	FCC ID	Data Cable	Power Cord
	N/A						

Remark:

1. *All the equipment/cables were placed in the worst-case configuration to maximize the emission during the test.*
2. *Grounding was established in accordance with the manufacturer's requirements and conditions for the intended use.*

7 FCC PART 15.247 REQUIREMENTS & RSS-247 REQUIREMENTS

7.1 99% BANDWIDTH

Test Configuration

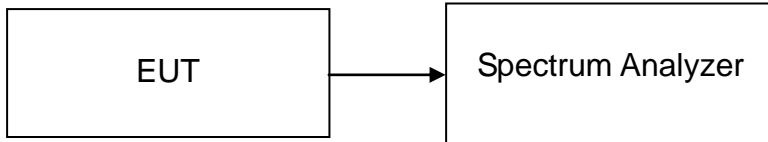

TEST PROCEDURE

The resolution bandwidth shall be set to as close to 1% of the selected span as is possible without being below 1%. The video bandwidth shall be set to 3 times the resolution bandwidth. Video averaging is not permitted. Where practical, a sampling detector shall be used since a peak or, peak hold.

TEST RESULTS

No non-compliance noted.

Test Data

For GFSK

Channel	Frequency (MHz)	99% Bandwidth (MHz)
Low	2402	1.0529
Mid	2440	1.0539
High	2480	1.0545

Test Plot

99% Bandwidth (CH Low)

Agilent

R L

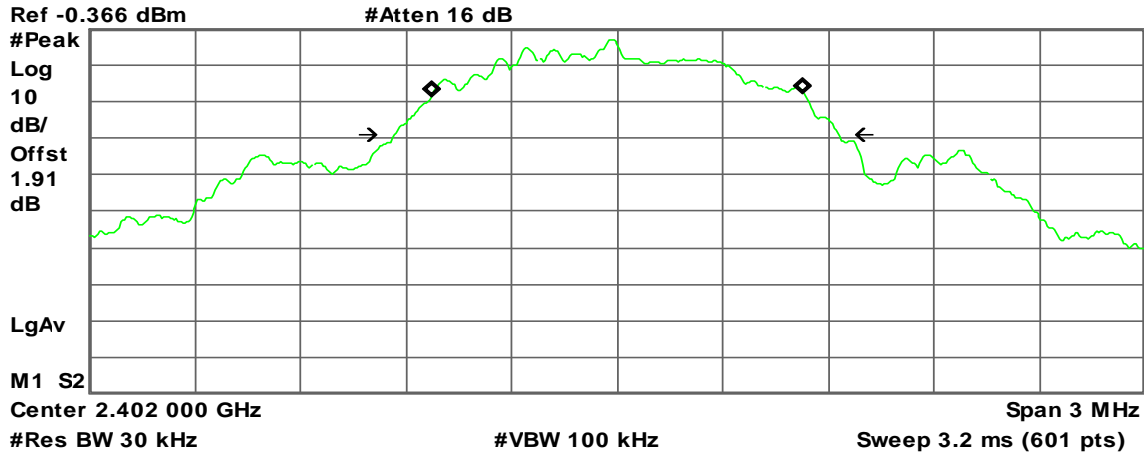

Occupied Bandwidth
1.0529 MHz

Occ BW % Pwr 99.00 %
x dB -26.00 dB

Transmit Freq Error 559.602 Hz
x dB Bandwidth 1.265 MHz

99% Bandwidth (CH Mid)

Agilent

R L

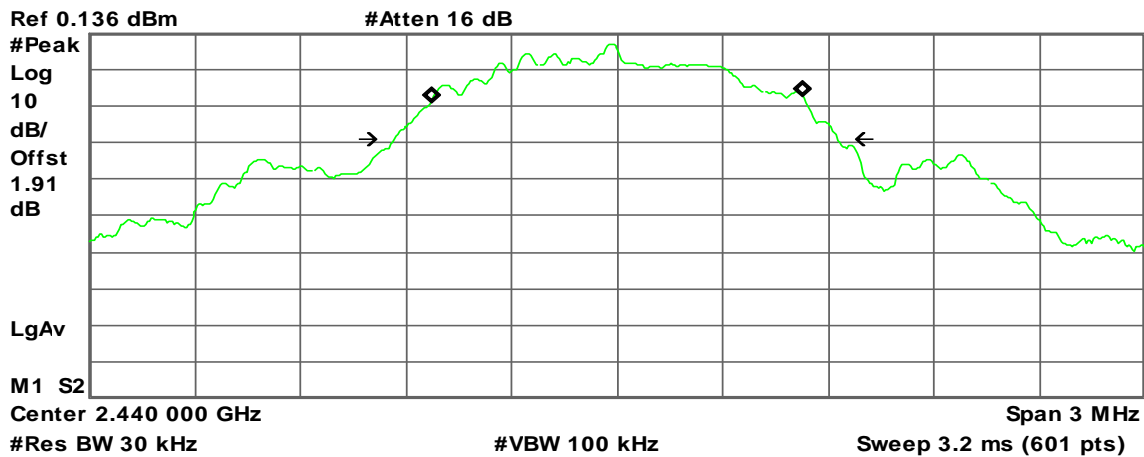

Occupied Bandwidth
1.0539 MHz

Occ BW % Pwr 99.00 %
x dB -26.00 dB

Transmit Freq Error -166.326 Hz
x dB Bandwidth 1.265 MHz

99% Bandwidth (CH High)

Agilent

R L

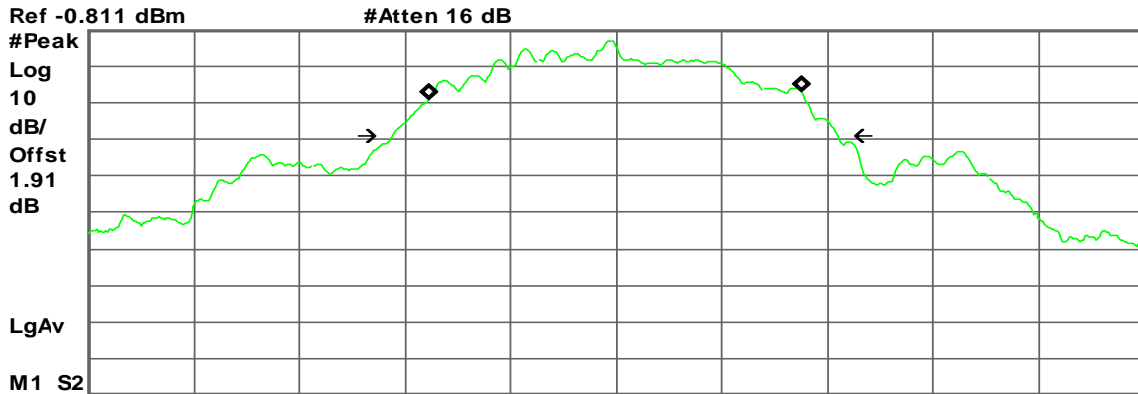

Center 2.480 000 GHz Span 3 MHz
 #Res BW 30 kHz #VBW 100 kHz Sweep 3.2 ms (601 pts)

Occupied Bandwidth
 1.0545 MHz

Occ BW % Pwr 99.00 %
 x dB -26.00 dB

Transmit Freq Error -1.601 kHz
 x dB Bandwidth 1.269 MHz

7.2 6DB BANDWIDTH

LIMIT

According to §15.247(a)(2) & RSS-247, systems using digital modulation techniques may operate in the 902 - 928 MHz, 2400 - 2483.5 MHz, and 5725 - 5850 MHz bands. The minimum 6dB bandwidth shall be at least 500 kHz.

Test Configuration

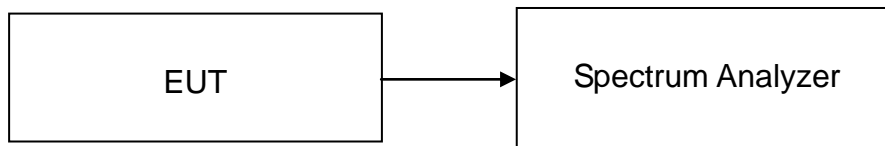

TEST PROCEDURE

The transmitter output is connected to the spectrum analyzer. Set the RBW = 1%-5% of the emission bandwidth, VBW $\geq 3 \times$ RBW, Detector = Peak, Trace mode = max hold, Sweep = auto couple. Measure the maximum width of the emission that is constrained by the frequencies associated with the two amplitude points (upper and lower) that are attenuated by 6dB relative to the maximum level measured in the fundamental emission.

TEST RESULTS

No non-compliance noted

Test Data

Channel	Frequency (MHz)	6dB Bandwidth (MHz)	Limit (kHz)	Test Result
Low	2402	0.59	>500	PASS
Mid	2440	0.59		PASS
High	2480	0.59		PASS

Test Plot

6dB Bandwidth (CH Low)

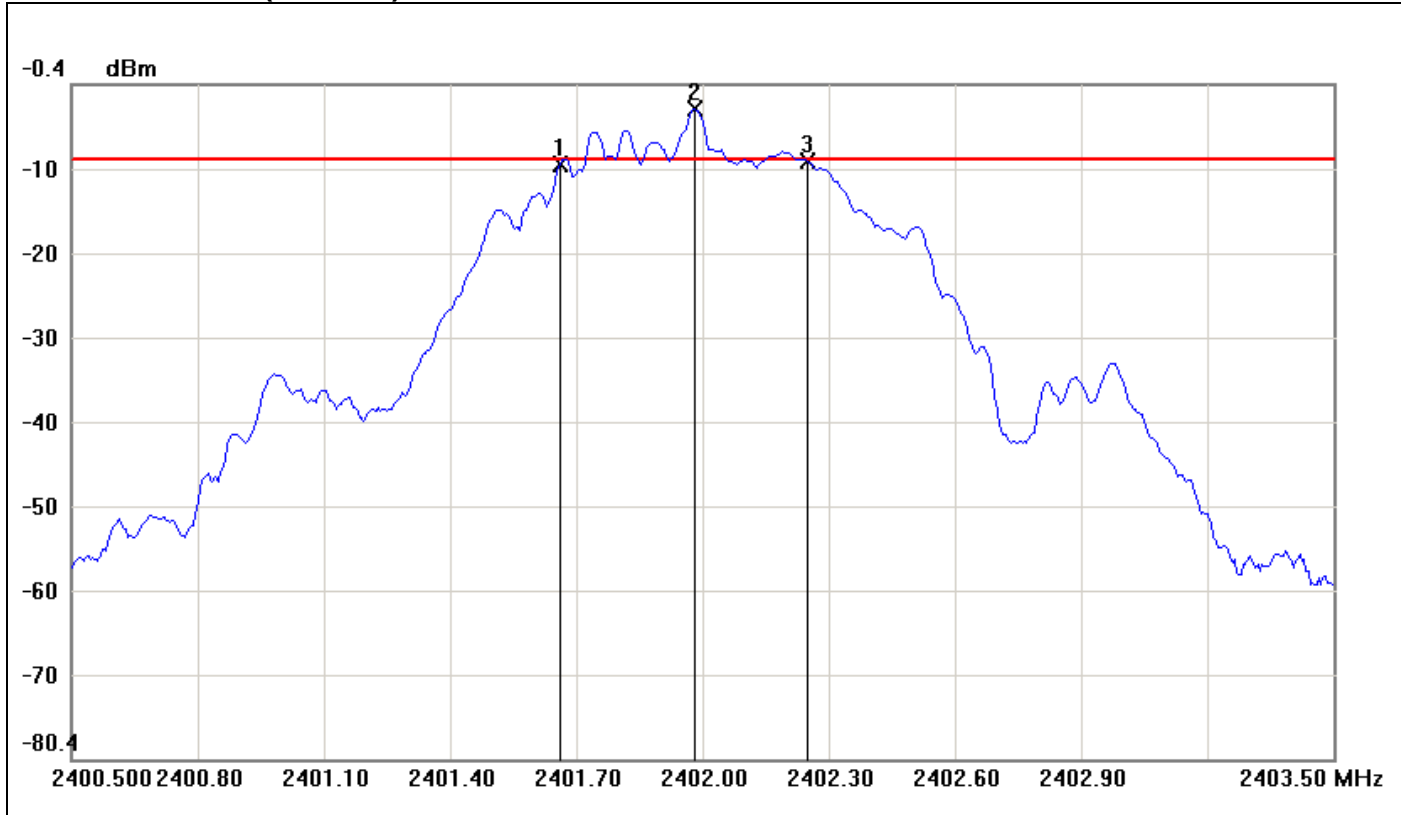

No.	Frequency(MHz)	Result(dBm)	Limit(dBm)	Margin(dBm)
1	2401.6600	-9.82	-9.35	-0.47
2	2401.9800	-3.35	-9.35	6.00
3	2402.2500	-9.39	-9.35	-0.04

No.		Δ Frequency(MHz)	Δ Level(dB)
1	mk3-mk1	0.59	0.43

6dB Bandwidth (CH Mid)

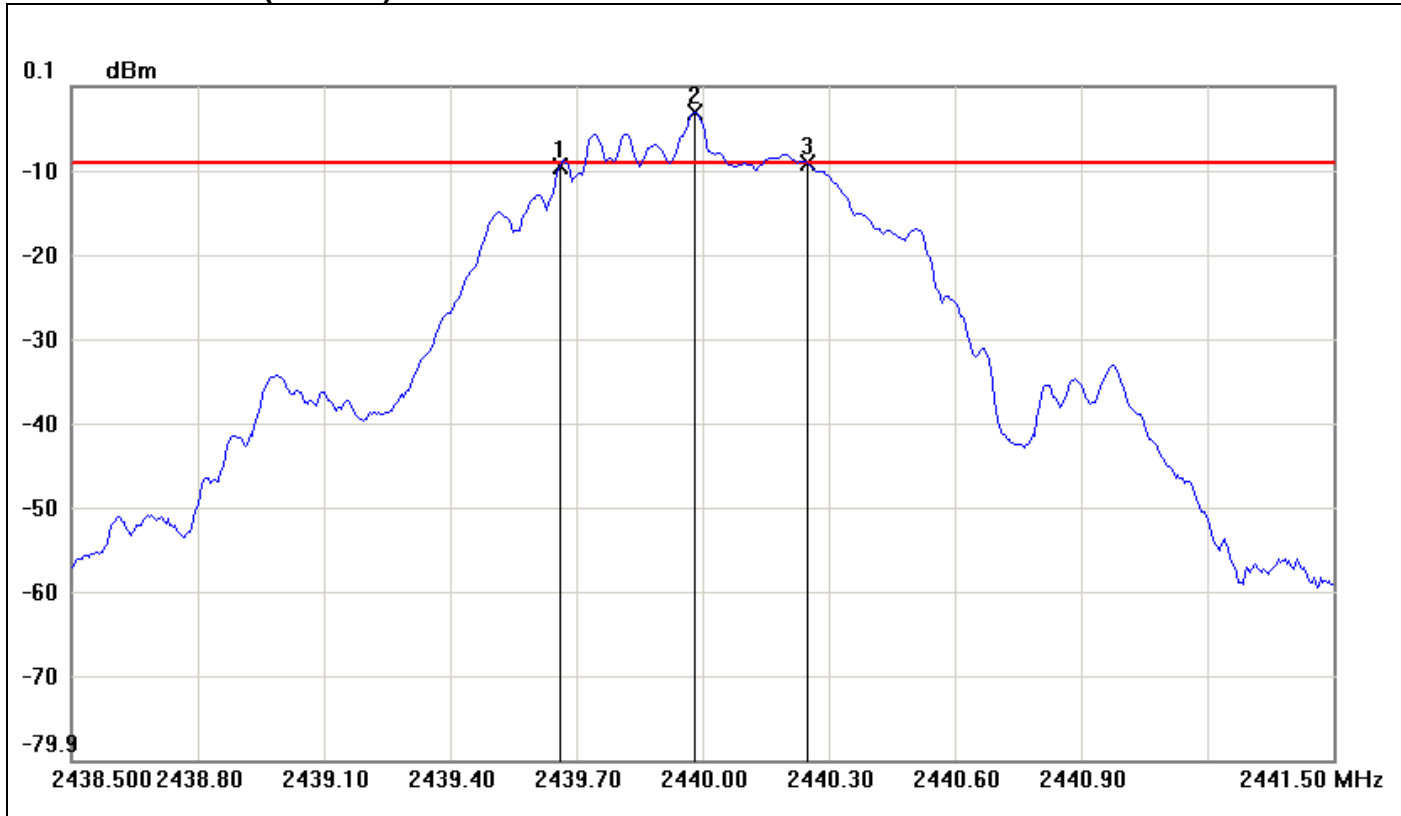

No.	Frequency(MHz)	Result(dBm)	Limit(dBm)	Margin(dBm)
1	2439.6600	-9.26	-8.94	-0.32
2	2439.9800	-2.94	-8.94	6.00
3	2440.2500	-9.03	-8.94	-0.09

No.		Δ Frequency(MHz)	Δ Level(dB)
1	mk3-mk1	0.59	0.23

6dB Bandwidth (CH High)

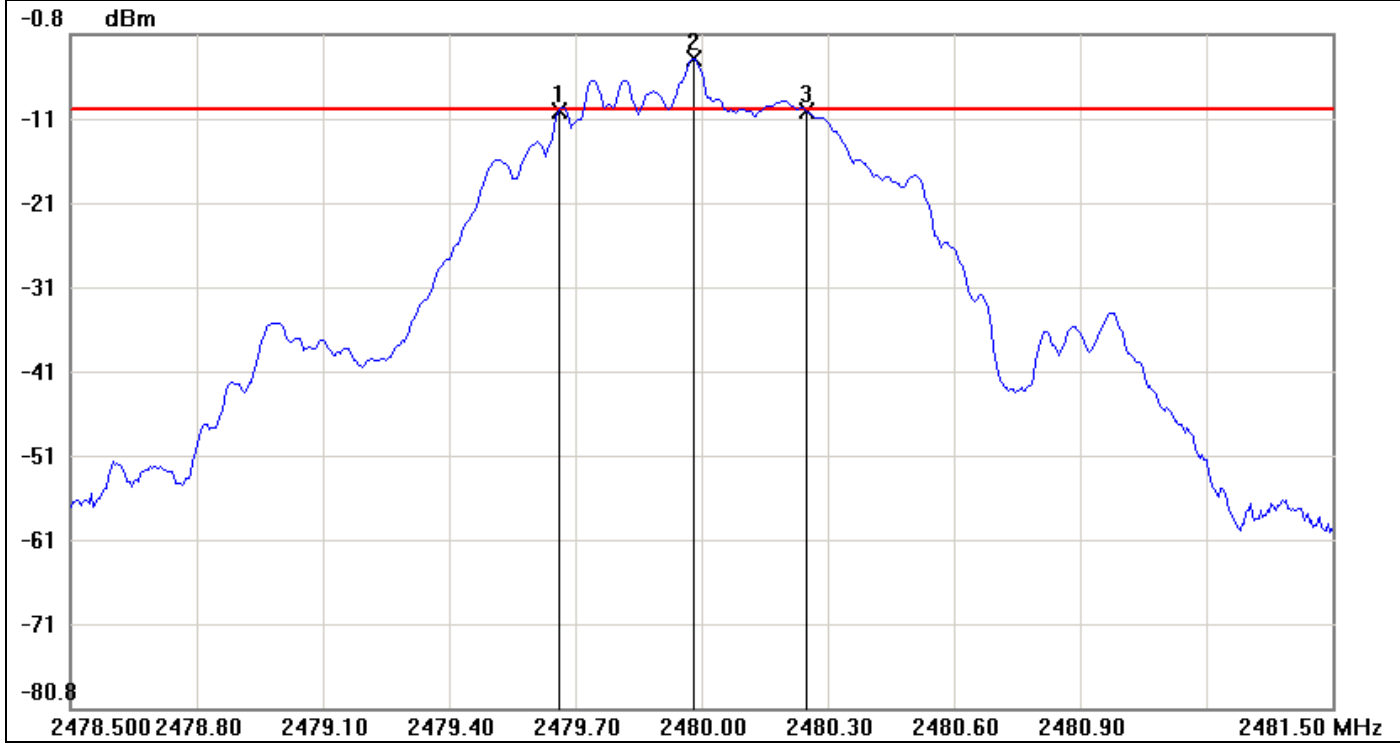

No.	Frequency(MHz)	Result(dBm)	Limit(dBm)	Margin(dBm)
1	2479.6600	-9.92	-9.72	-0.20
2	2479.9800	-3.72	-9.72	6.00
3	2480.2500	-9.83	-9.72	-0.11

No.		Δ Frequency(MHz)	Δ Level(dB)
1	mk3-mk1	0.59	0.09

7.3 PEAK POWER

LIMIT

The maximum peak output power of the intentional radiator shall not exceed the following:

1. According to §15.247(b)(3), for systems using digital modulation in the bands of 902-928 MHz, 2400-2483.5 MHz, and 5725-5850 MHz: 1 Watt.
2. According to §15.247(b)(4), the conducted output power limit specified in paragraph (b) of this section is based on the use of antennas with directional gains that do not exceed 6 dBi. Except as shown in paragraph (c) of this section, if transmitting antennas of directional gain greater than 6 dBi are used, the conducted output power from the intentional radiator shall be reduced below the stated values in paragraphs (b)(1), (b)(2), and (b)(3) of this section, as appropriate, by the amount in dB that the directional gain of the antenna exceeds 6 dBi.
3. According to RSS-247, for systems employing digital modulation techniques operating in the bands 902-928 MHz, 2400-2483.5 MHz and 5725-5850 MHz, the maximum peak conducted output power shall not exceed 1 W.

Test Configuration

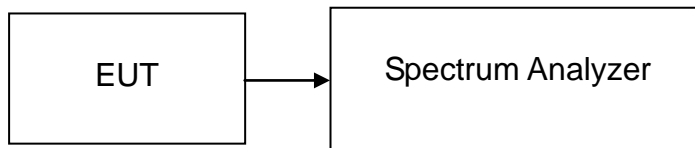

TEST PROCEDURE

The transmitter output is connected to the spectrum analyzer. Set the RBW = 1MHz , VBW = 3MHz, Detector = Peak, Trace mode = max hold, Sweep = auto couple. Record the max reading.

Repeat the above procedure until the measurements for all frequencies are completed.

TEST RESULTS

No non-compliance noted

Test Data

Channel	Frequency (MHz)	Output Power (dBm)	Output Power (W)	Limit (W)	Test Result
Low	2402	-0.99	0.0008	1	PASS
Mid	2440	*-0.83	0.0008		PASS
High	2480	-0.84	0.0008		PASS

7.4 AVERAGE POWER

LIMIT

None; for reporting purposes only.

Test Configuration

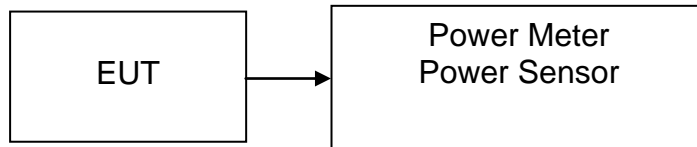

TEST PROCEDURE

The transmitter output is connected to the Power Meter. The Power Meter is set to the average power detection.

TEST RESULTS

No non-compliance noted.

Test Data

Channel	Frequency (MHz)	Output Power (dBm)	Output Power (W)
Low	2402	-1.35	0.0007
Mid	2440	*-1.18	0.0008
High	2480	-1.21	0.0008

7.5 BAND EDGES MEASUREMENT

LIMIT

According to §15.247(d) & RSS-247, in any 100 kHz bandwidth outside the frequency bands in which the spread spectrum intentional radiator is operating, the radio frequency power that is produced by the intentional radiator shall be at least 20 dB below that in the 100 kHz bandwidth within the band that contains the highest level of the desired power, based on either an RF conducted or a radiated measurement, provided the transmitter demonstrates compliance with the peak conducted power limits. In addition, radiated emissions which fall in the restricted bands, as defined in §15.205(a), must also comply with the radiated emission limits specified in 15.209(a) (see Section 15.205(c)).

Test Configuration

For Radiated

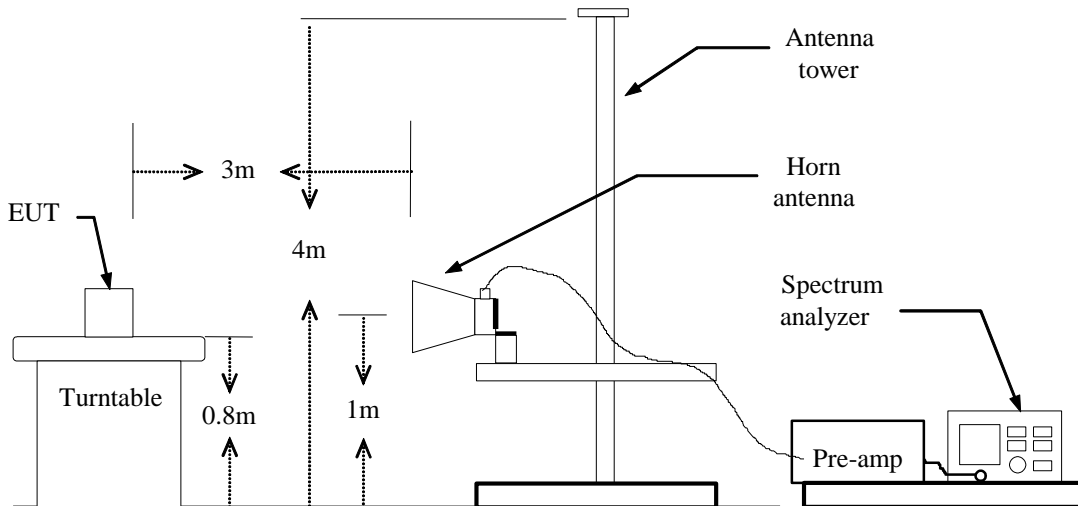

For Conducted

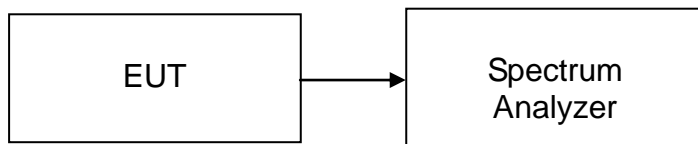

TEST PROCEDURE

For Radiated

1. The EUT is placed on a turntable, which is 1.5m above the ground plane.
2. The turntable shall be rotated for 360 degrees to determine the position of maximum emission level.
3. EUT is set 3m away from the receiving antenna, which is varied from 1m to 4m to find out the highest emission.
4. Set the spectrum analyzer in the following setting in order to capture the lower and upper band-edges of the emission:
 - (a) PEAK: RBW=1MHz / VBW=3MHz / Sweep=AUTO
 - (b) AVERAGE: RBW=1MHz,
if duty cycle $\geq 98\%$, VBW=10Hz.
if duty cycle $< 98\%$ VBW=1/T.
BT4.0: = 66%, VBW= 2.4KHz
5. Repeat the procedures until all the PEAK and AVERAGE versus POLARIZATION are measured.

For Conducted

Conducted RF measurements of the transmitter output were made to confirm that the EUT antenna port conducted emissions meet the specified limit and to identify any spurious signals that require further investigation or measurements on the radiated emissions site.

The transmitter output is connected to the spectrum analyzer. The resolution bandwidth is set to 100 kHz. The video bandwidth is set to 100 kHz.

TEST RESULTS

Refer to attach spectrum analyzer data chart.

Band Edges (CH Low)

Polarity: Vertical

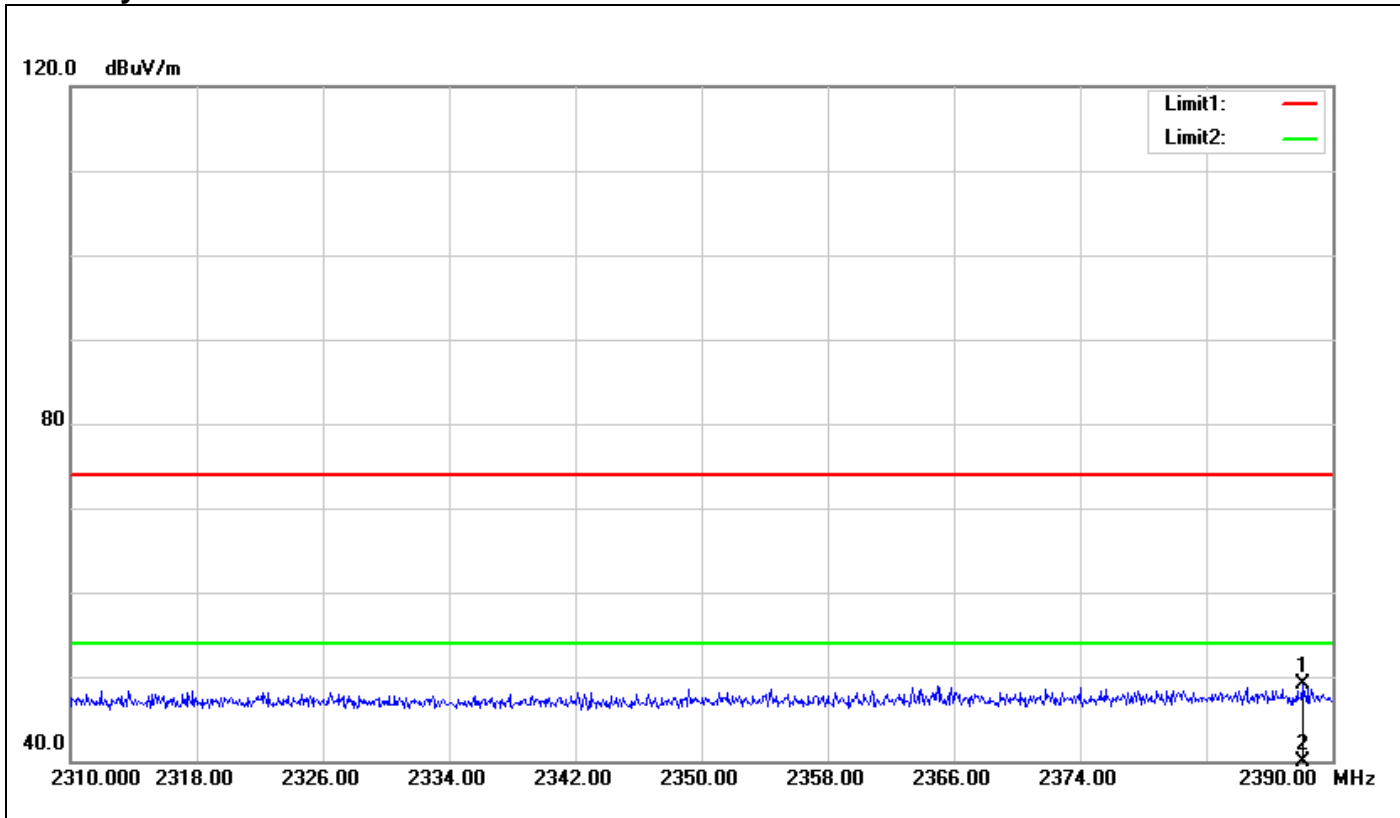

No.	Frequency (MHz)	Reading (dBuV)	Correct Factor(dB/m)	Result (dBuV/m)	Limit (dBuV/m)	Margin (dB)	Height (cm)	Degree (°)	Remark
1	2388.080	51.53	-2.51	49.02	74.00	-24.98	100	339	peak
2	2388.080	39.00	-2.51	36.49	54.00	-17.51	100	339	AVG

Polarity: Horizontal

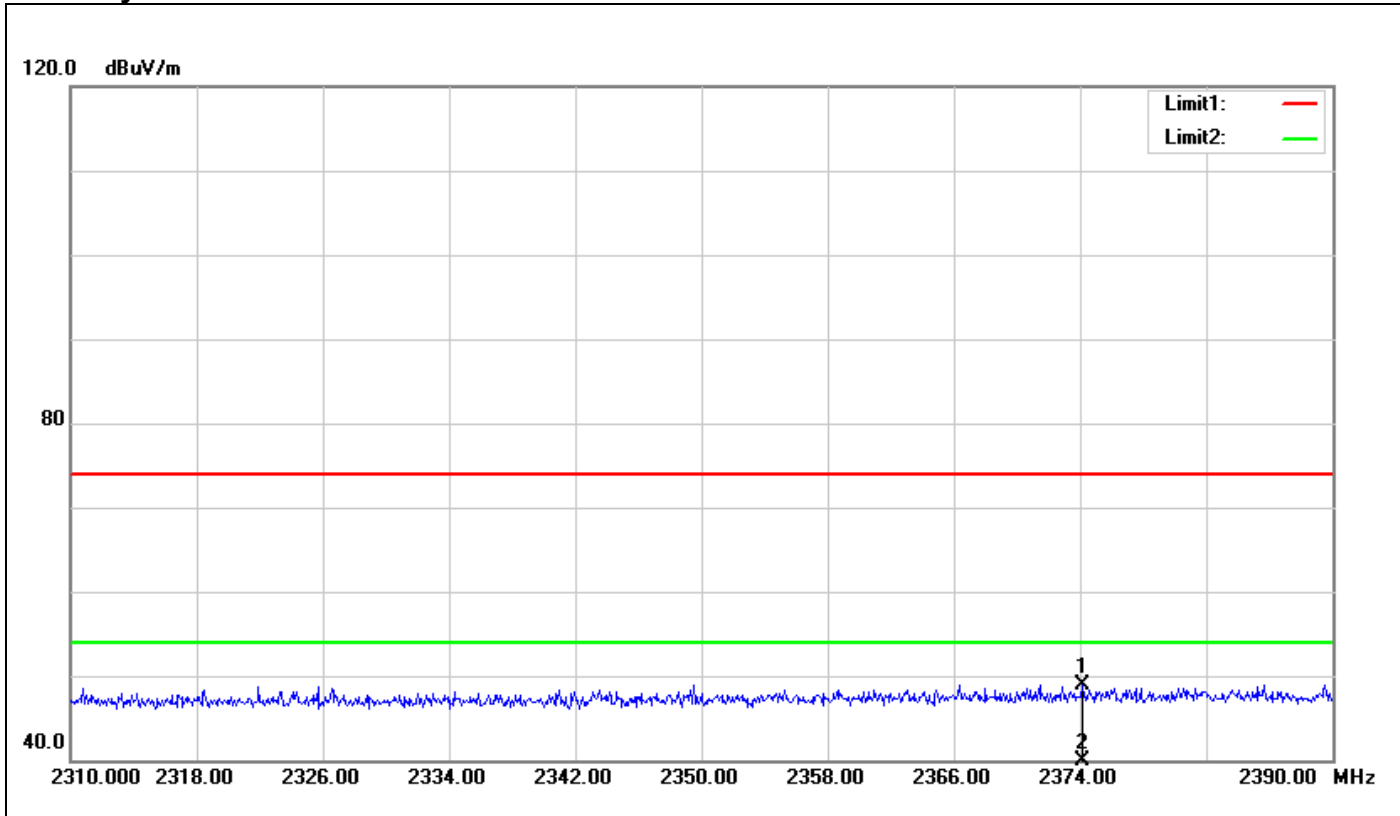

No.	Frequency (MHz)	Reading (dBuV)	Correct Factor(dB/m)	Result (dBuV/m)	Limit (dBuV/m)	Margin (dB)	Height (cm)	Degree (°)	Remark
1	2374.160	51.55	-2.62	48.93	74.00	-25.07	100	23	peak
2	2374.160	39.33	-2.62	36.71	54.00	-17.29	100	23	AVG

Band Edges (CH High)

Polarity: Vertical

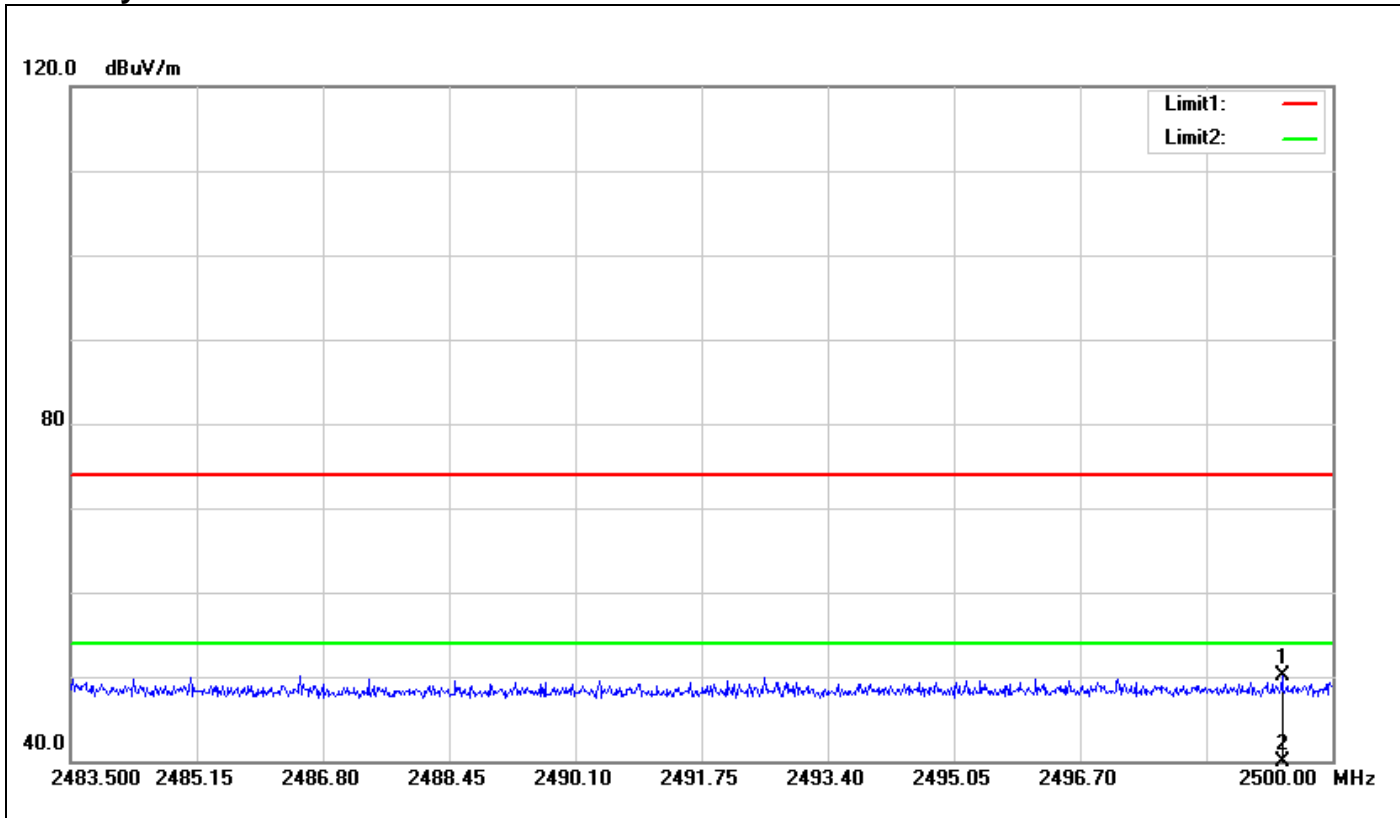

No.	Frequency (MHz)	Reading (dBuV)	Correct Factor(dB/m)	Result (dBuV/m)	Limit (dBuV/m)	Margin (dB)	Height (cm)	Degree (°)	Remark
1	2499.340	51.99	-1.86	50.13	74.00	-23.87	100	334	peak
2	2499.340	39.50	-1.86	37.64	54.00	-16.36	100	334	AVG

Polarity: Horizontal

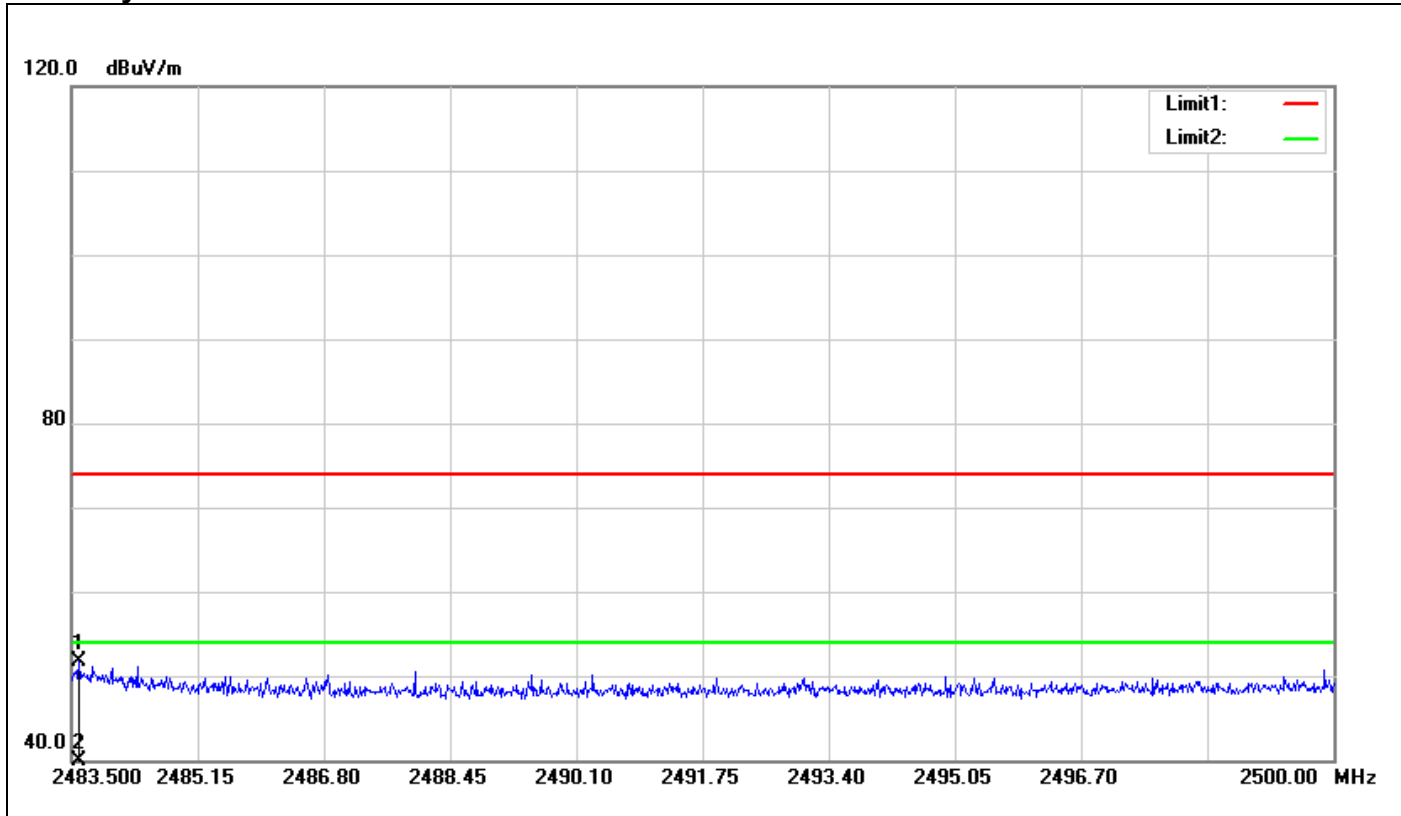

No.	Frequency (MHz)	Reading (dBuV)	Correct Factor(dB/m)	Result (dBuV/m)	Limit (dBuV/m)	Margin (dB)	Height (cm)	Degree (°)	Remark
1	2483.599	53.65	-1.99	51.66	74.00	-22.34	100	112	peak
2	2483.599	40.96	-1.99	38.97	54.00	-15.03	100	112	AVG

Conducted Band Edges (CH Low)

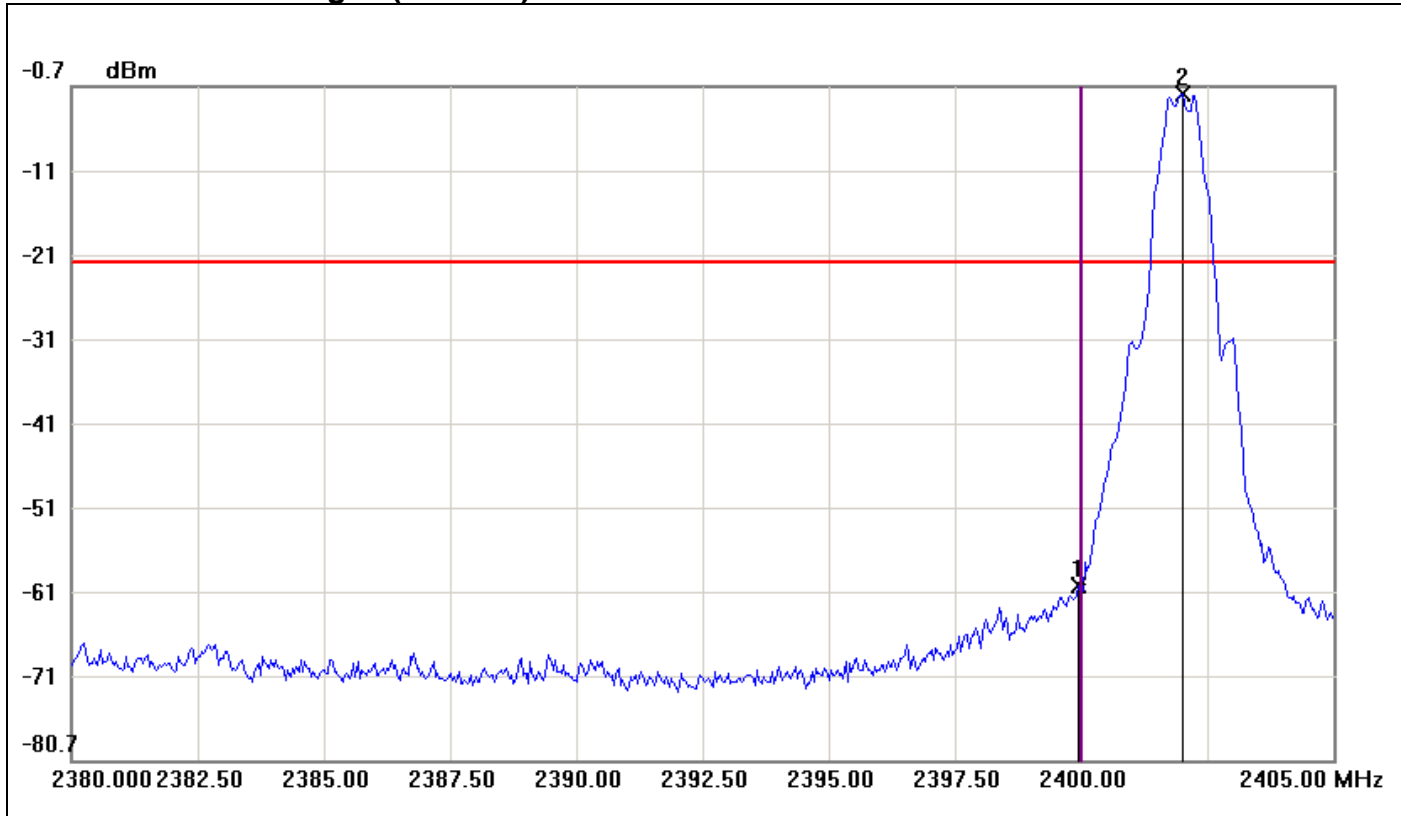

No.	Frequency(MHz)	Result(dBm)	Limit(dBm)	Margin(dBm)
1	2399.9583	-59.93	-21.57	-38.36
2	2402.0000	-1.57	-21.57	20.00

Conducted Band Edges (CH High)

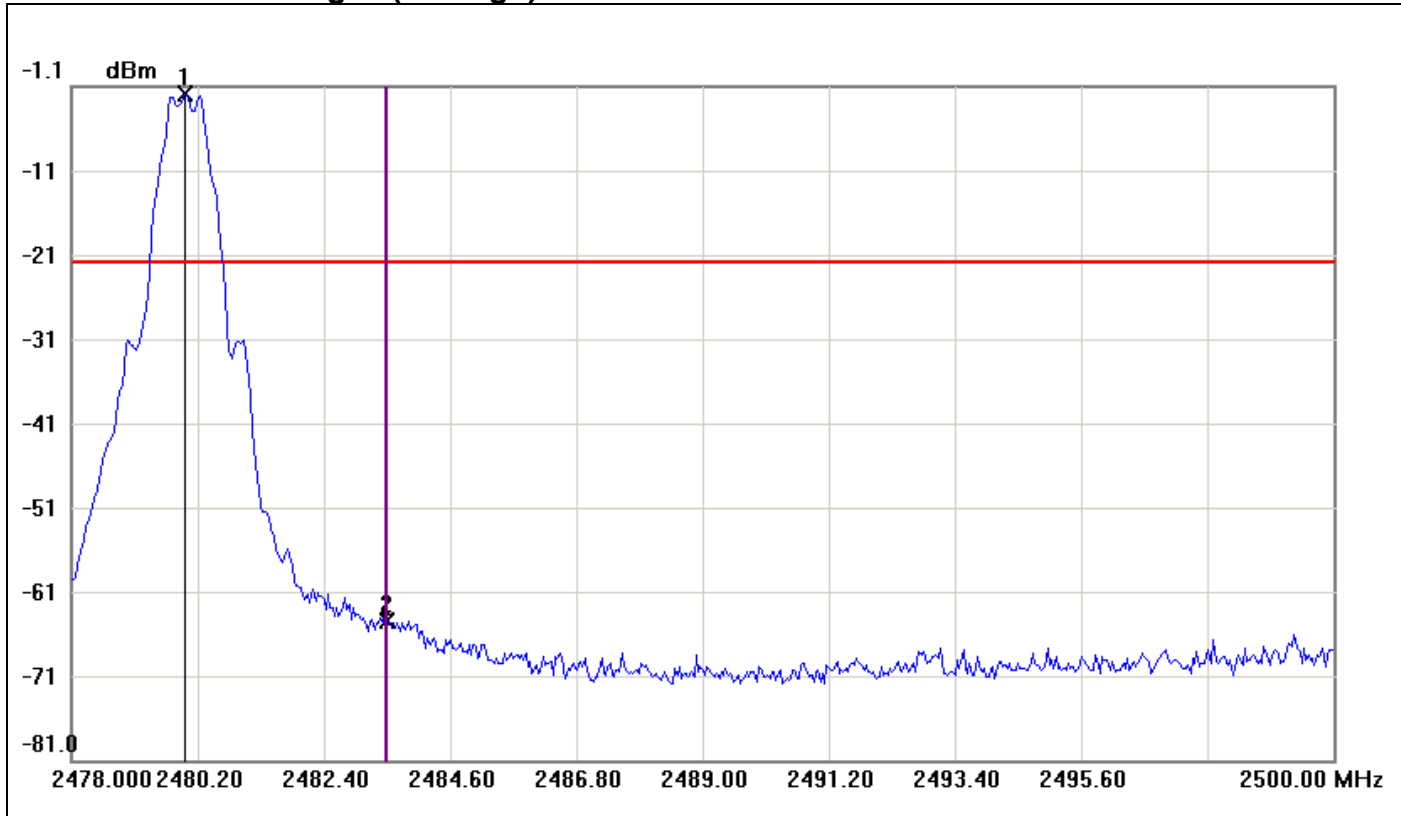

No.	Frequency(MHz)	Result(dBm)	Limit(dBm)	Margin(dBm)
1	2479.9800	-1.96	-21.96	20.00
2	2483.5000	-64.51	-21.96	-42.55

7.6 PEAK POWER SPECTRAL DENSITY

LIMIT

1. According to §15.247(e) & RSS-247, for digitally modulated systems, the power spectral density conducted from the intentional radiator to the antenna shall not be greater than 8 dBm in any 3 kHz band during any time interval of continuous transmission.
2. According to §15.247(f) & RSS-247, the digital modulation operation of the hybrid system, with the frequency hopping turned off, shall comply with the power density requirements of paragraph (d) of this section.

Test Configuration

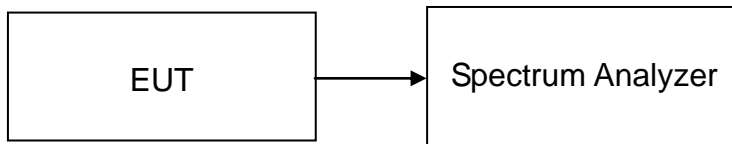

TEST PROCEDURE

The transmitter output is connected to a spectrum analyzer. Set the RBW = 100 kHz, VBW 300 kHz, span 5-30% greater than EBW, Detector = peak, Trace mode = max hold, Sweep = auto couple. Scale the observed power level to an equivalent value in 3 kHz by adjusting (reducing) the measured power by a bandwidth correction factor (BWCF) where $BWCF = 10 \log(3 \text{ kHz}/100 \text{ kHz} = -15.2 \text{ dB})$. Record the maximum reading. Repeat the above procedure until the measurements for all frequencies are completed.

TEST RESULTS

No non-compliance noted

Test Data

Channel	Frequency (MHz)	PPSD (dBm)	Limit (dBm)	Result
Low	2402	-3.50	8.00	PASS
Mid	2440	-2.82		PASS
High	2480	-3.80		PASS

Test Plot

PPSD (CH Low)

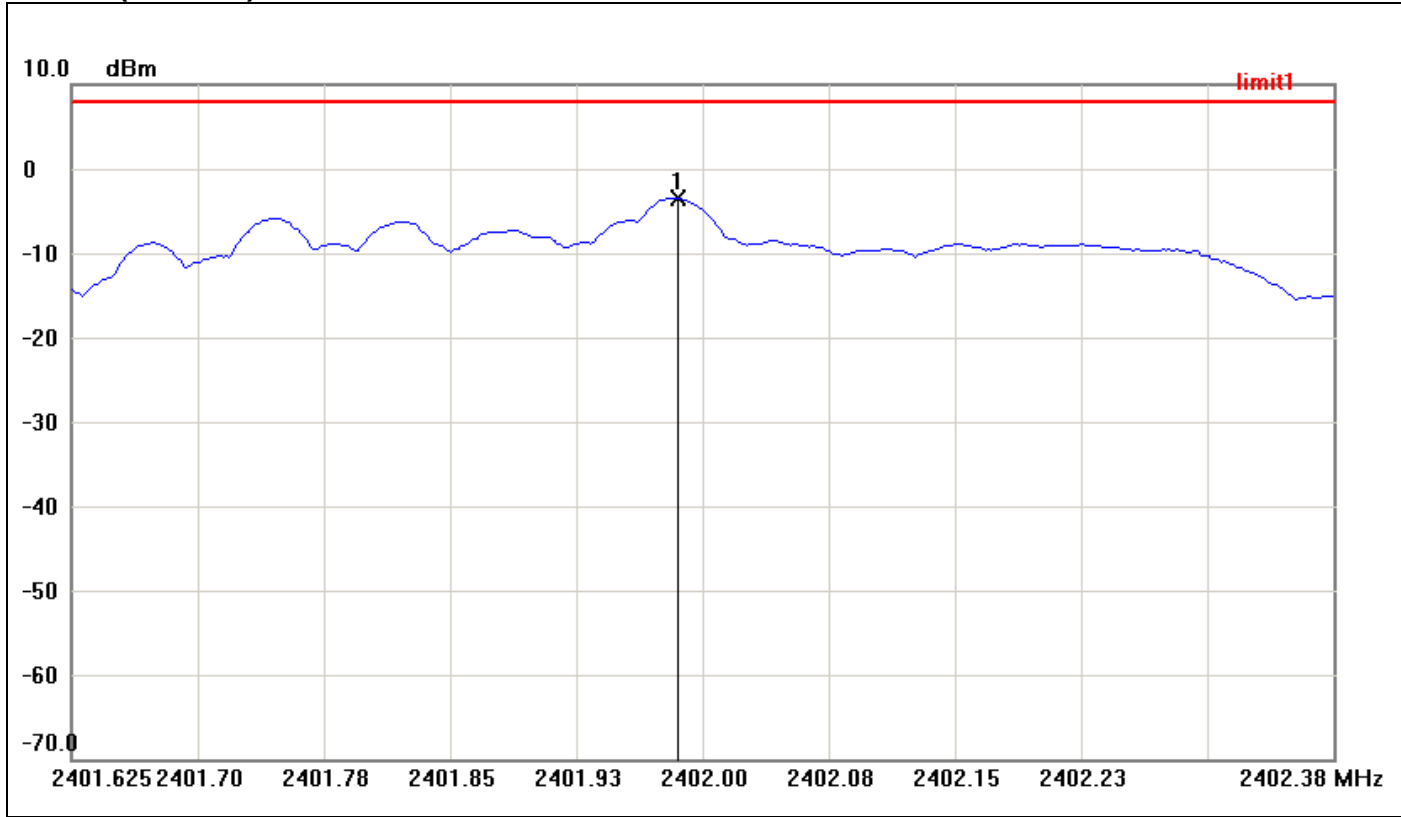

No.	Frequency(MHz)	Result(dBm)	Limit(dBm)	Margin(dBm)
1	2401.9850	-3.50	8.00	-11.50

PPSD (CH Mid)

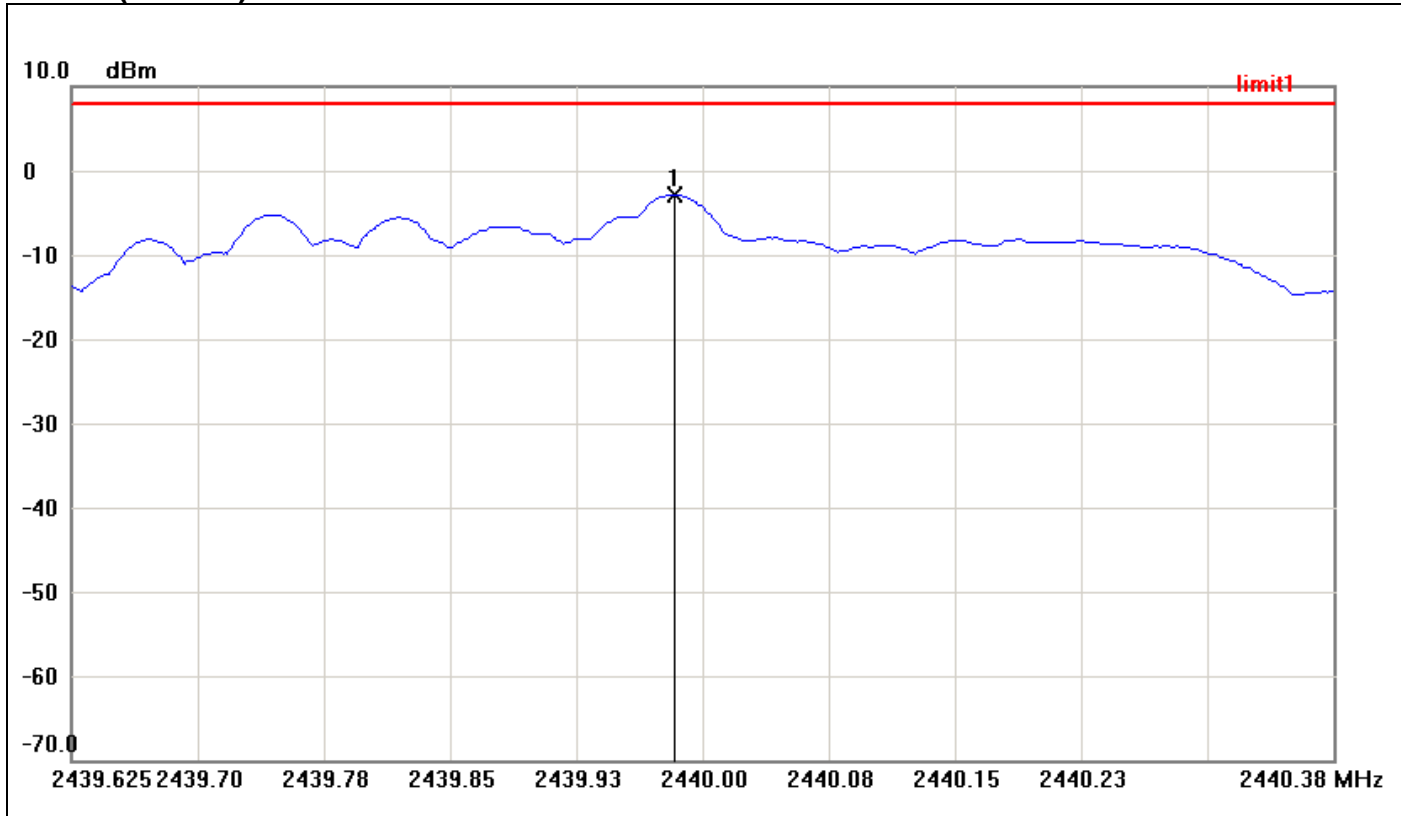

No.	Frequency(MHz)	Result(dBm)	Limit(dBm)	Margin(dBm)
1	2439.9837	-2.82	8.00	-10.82

PPSD (CH High)

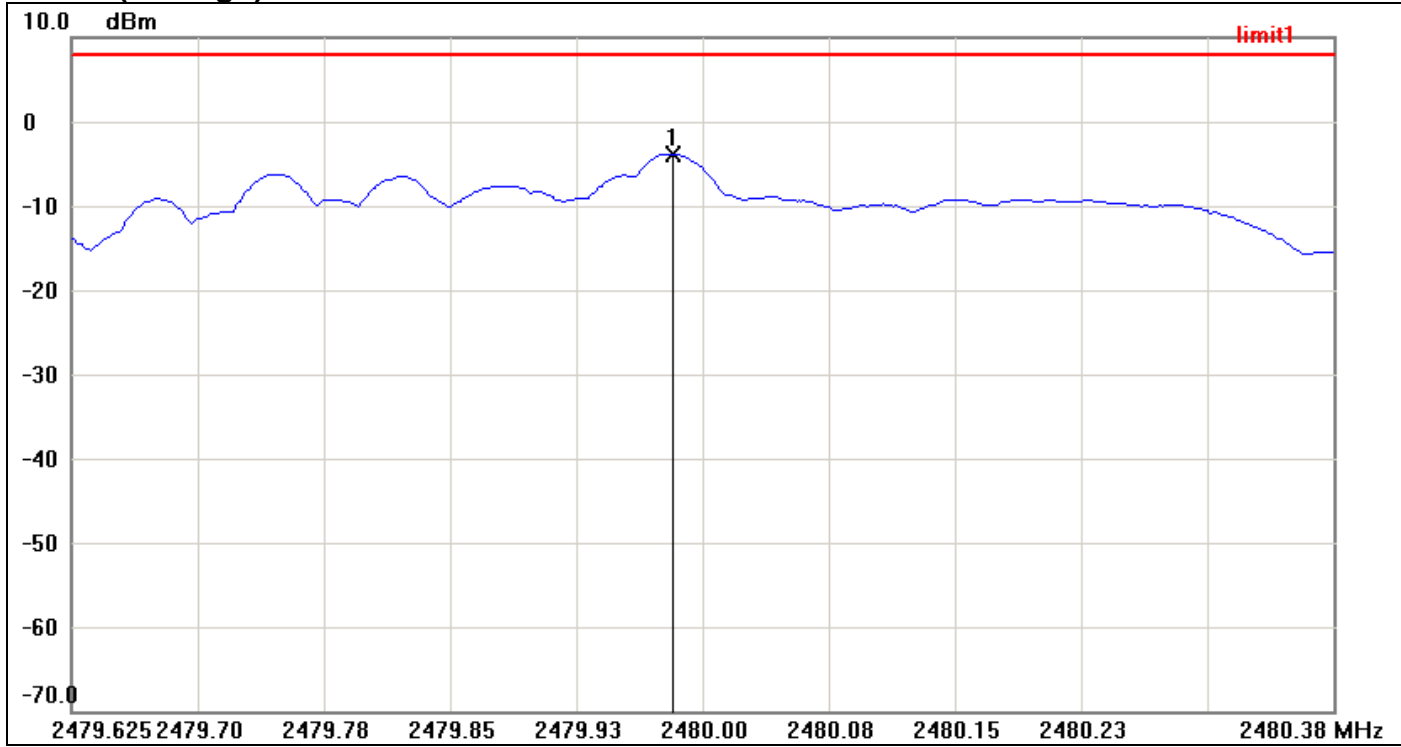

No.	Frequency(MHz)	Result(dBm)	Limit(dBm)	Margin(dBm)
1	2479.9825	-3.80	8.00	-11.80

7.7 SPURIOUS EMISSIONS

7.7.1 Conducted Measurement

LIMIT

According to §15.247(d) & RSS-247, in any 100 kHz bandwidth outside the frequency bands in which the spread spectrum intentional radiator is operating, the radio frequency power that is produced by the intentional radiator shall be at least 20 dB below that in the 100 kHz bandwidth within the band that contains the highest level of the desired power, based on either an RF conducted or a radiated measurement, provided the transmitter demonstrates compliance with the peak conducted power limits. In addition, radiated emissions which fall in the restricted bands, as defined in §15.205(a), must also comply with the radiated emission limits specified in 15.209(a) (see Section 15.205(c)).

Test Configuration

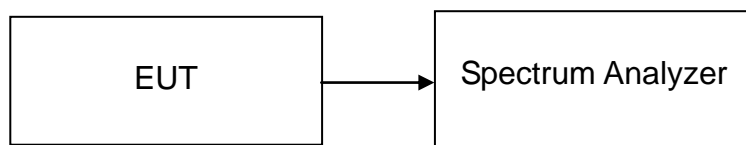

TEST PROCEDURE

Conducted RF measurements of the transmitter output were made to confirm that the EUT antenna port conducted emissions meet the specified limit and to identify any spurious signals that require further investigation or measurements on the radiated emissions site.

The transmitter output is connected to the spectrum analyzer. The resolution bandwidth is set to 100 kHz. The video bandwidth is set to 100 kHz.

Measurements are made over the 30MHz to 26GHz range with the transmitter set to the lowest, middle, and highest channels.

TEST RESULTS

No non-compliance noted

Test Plot

CH Low



No.	Frequency(MHz)	Result(dBm)	Limit(dBm)	Margin(dBm)
1	2352.2100	-64.54	-21.52	-43.02
2	3201.1900	-55.44	-21.52	-33.92

CH Mid

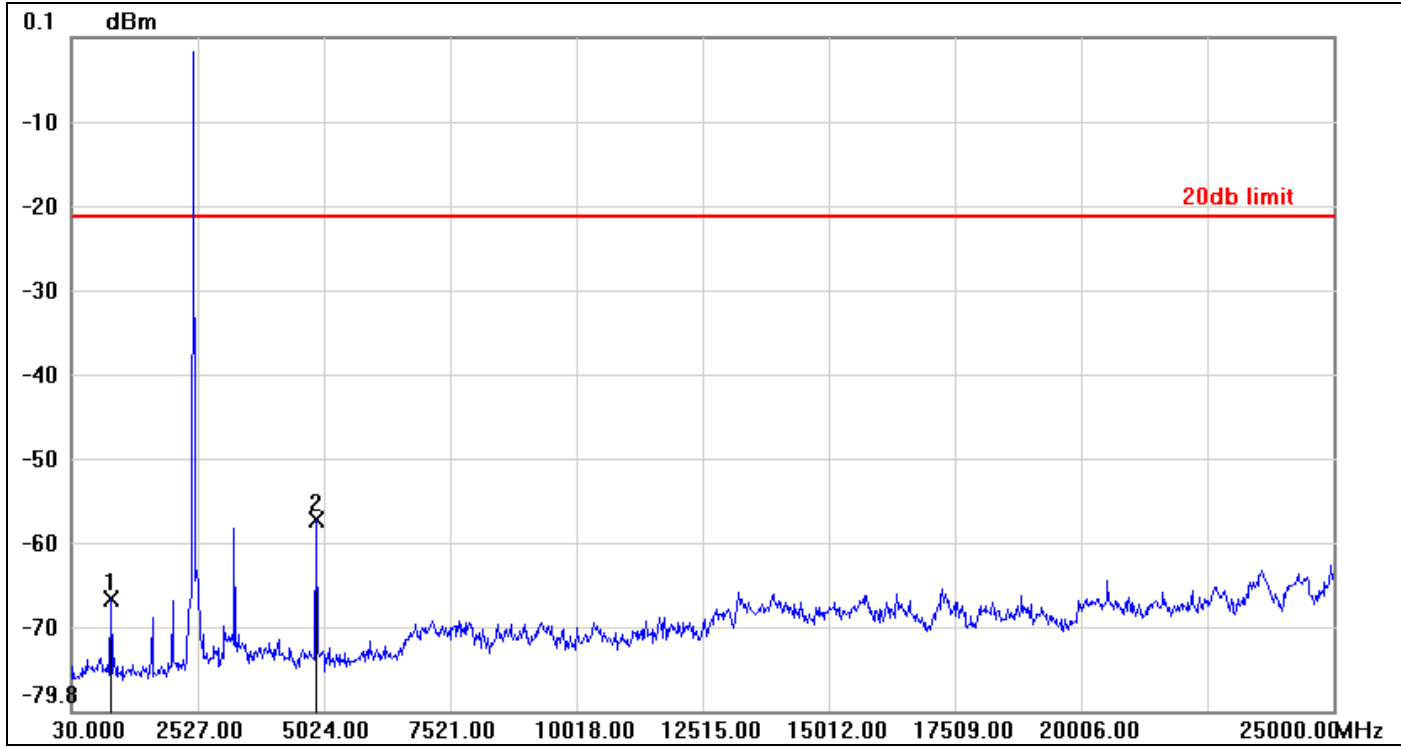

No.	Frequency(MHz)	Result(dBm)	Limit(dBm)	Margin(dBm)
1	804.0700	-66.55	-21.12	-45.43
2	4874.1800	-57.20	-21.12	-36.08

CH High

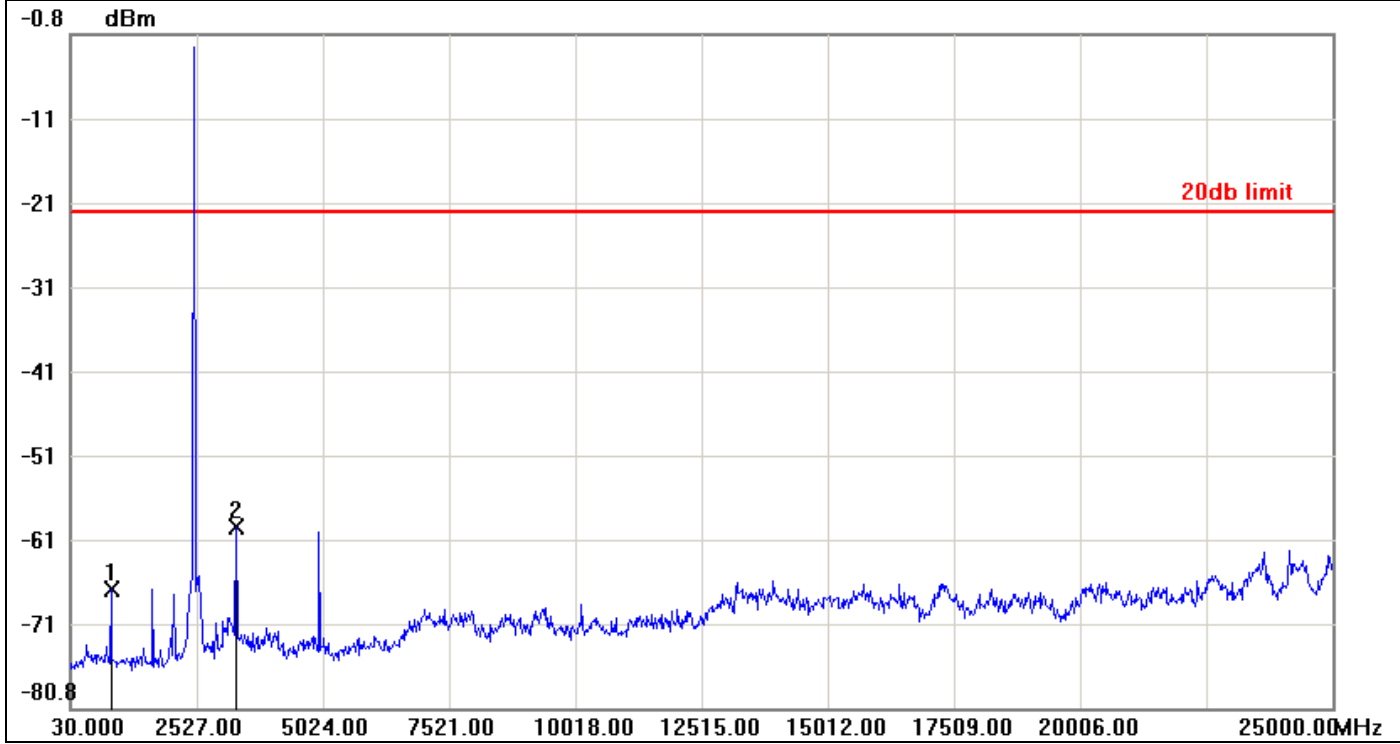

No.	Frequency(MHz)	Result(dBm)	Limit(dBm)	Margin(dBm)
1	829.0400	-66.67	-21.90	-44.77
2	3301.0700	-59.34	-21.90	-37.44

7.8 RADIATED EMISSIONS

LIMIT

All spurious emissions shall comply with the limits of §15.209(a) and RSS-Gen Table 2 & Table 5.

RSS-Gen Table 2 & Table 5: General Field Strength Limits for Transmitters and Receivers at Frequencies Above 30 MHz ^(Note)

Frequency (MHz)	Field Strength microvolts/m at 3 metres (watts, e.i.r.p.)	
	Transmitters	Receivers
30-88	100 (3 nW)	100 (3 nW)
88-216	150 (6.8 nW)	150 (6.8 nW)
216-960	200 (12 nW)	200 (12 nW)
Above 960	500 (75 nW)	500 (75 nW)

Note: *Measurements for compliance with limits in the above table may be performed at distances other than 3 metres, in accordance with Section 7.2.7.

Transmitting devices are not permitted in Table 1 bands or, unless stated otherwise, in TV bands (54-72 MHz, 76-88 MHz, 174-216 MHz, 470-608 MHz and 614-806 MHz).

RSS-Gen Table 6: General Field Strength Limits for Transmitters at Frequencies Below 30 MHz (Transmit)

Frequency	Field Strength (microvolts/m)	Magnetic H-Field (microamperes/m)	Measurement Distance (metres)
9-490 kHz	2,400/F (F in kHz)	2,400/377F (F in kHz)	3000
490-1,705 kHz	24,000/F (F in kHz)	24,000/377F (F in kHz)	30
1.705-30 MHz	30	N/A	30

Note: The emission limits for the bands 9-90 kHz and 110-490 kHz are based on measurements employing an average detector.

Test Configuration

9kHz ~ 30MHz

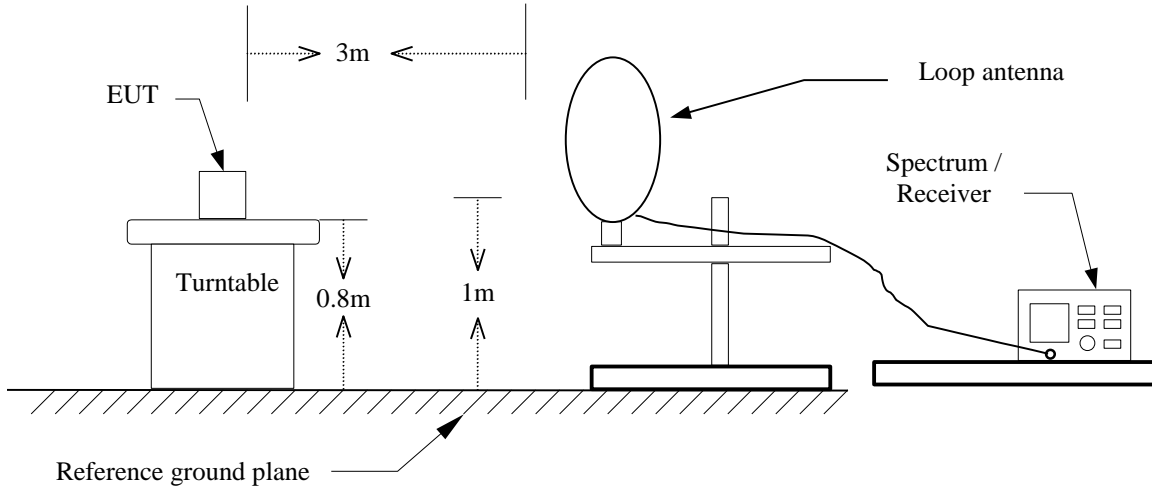

30MHz ~ 1GHz

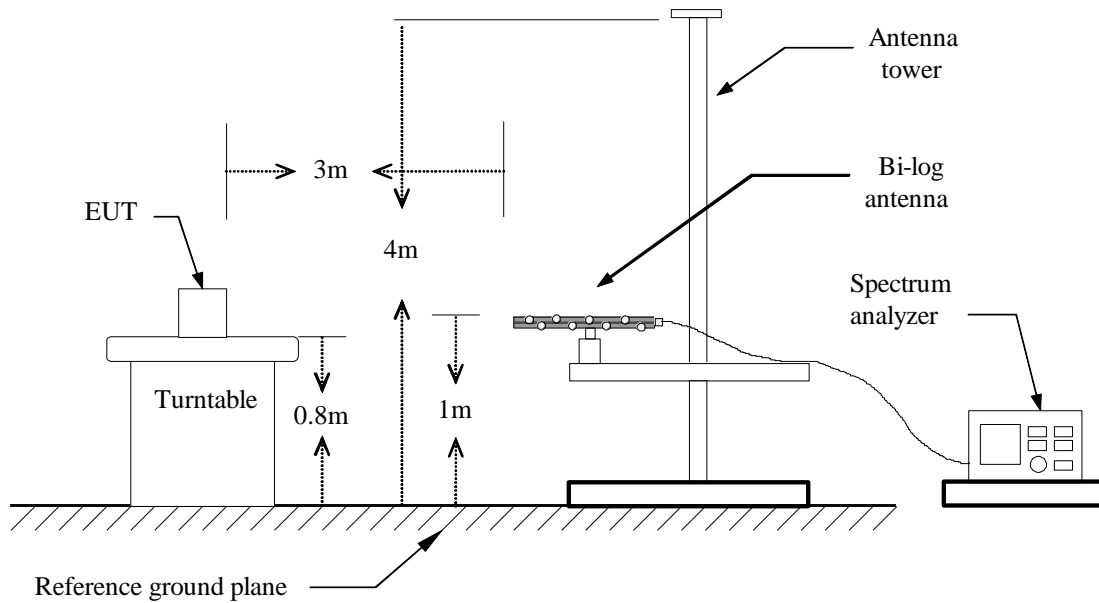

Above 1 GHz

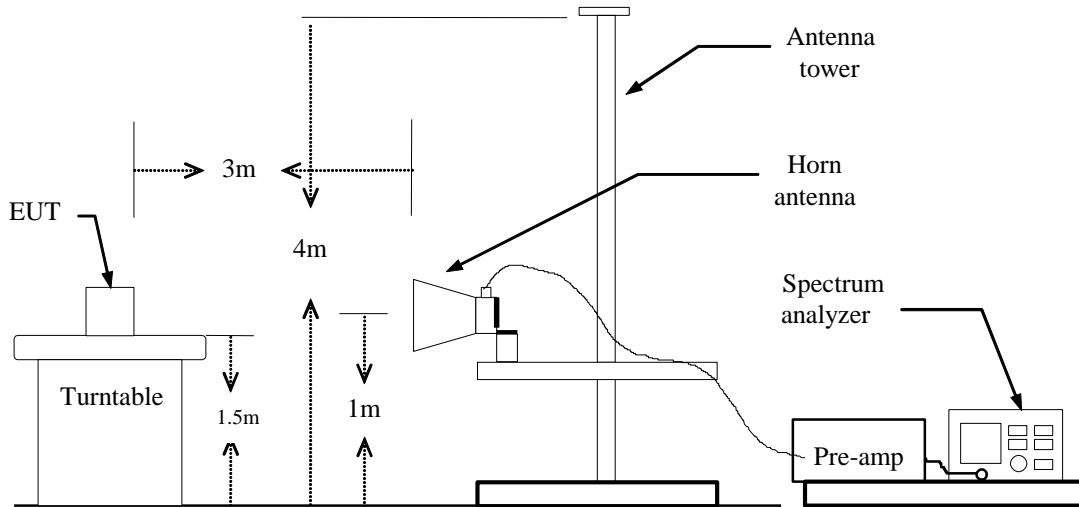

TEST PROCEDURE

1. The EUT is placed on a turntable, which is 1.5m above ground plane.
2. The turntable shall be rotated for 360 degrees to determine the position of maximum emission level.
3. EUT is set 3m away from the receiving antenna, which is varied from 1m to 4m to find out the highest emissions.
4. Maximum procedure was performed on the six highest emissions to ensure EUT compliance.
5. And also, each emission was to be maximized by changing the polarization of receiving antenna both horizontal and vertical.
6. Set the spectrum analyzer in the following setting as:

Below 1GHz:

RBW=100kHz / VBW=300kHz / Sweep=AUTO

Above 1GHz:

(a) PEAK: RBW=1MHz / VBW=3MHz / Sweep=AUTO

(b) AVERAGE: RBW=1MHz,
if duty cycle \geq 98%, VBW=10Hz.
if duty cycle < 98% VBW=1/T.

BT4.0: = 66%, VBW= 2.4KHz

7. Repeat above procedures until the measurements for all frequencies are complete.

Below 30MHz

No emissions to be recorded.

(Since no specific emission noted beyond the background noise floor.)

Remark: 1. The measurement below 30MHz is tested with a loop antenna per KDB460108.

2. For 15.31(o) for the reporting of emissions that are more than 20dB below the limit.

Below 1 GHz

Operation Mode: Normal Link

Test Date: July 21, 2015

Temperature: 27°C

Tested by: Jason Lu

Humidity: 53% RH

Polarity: Ver.

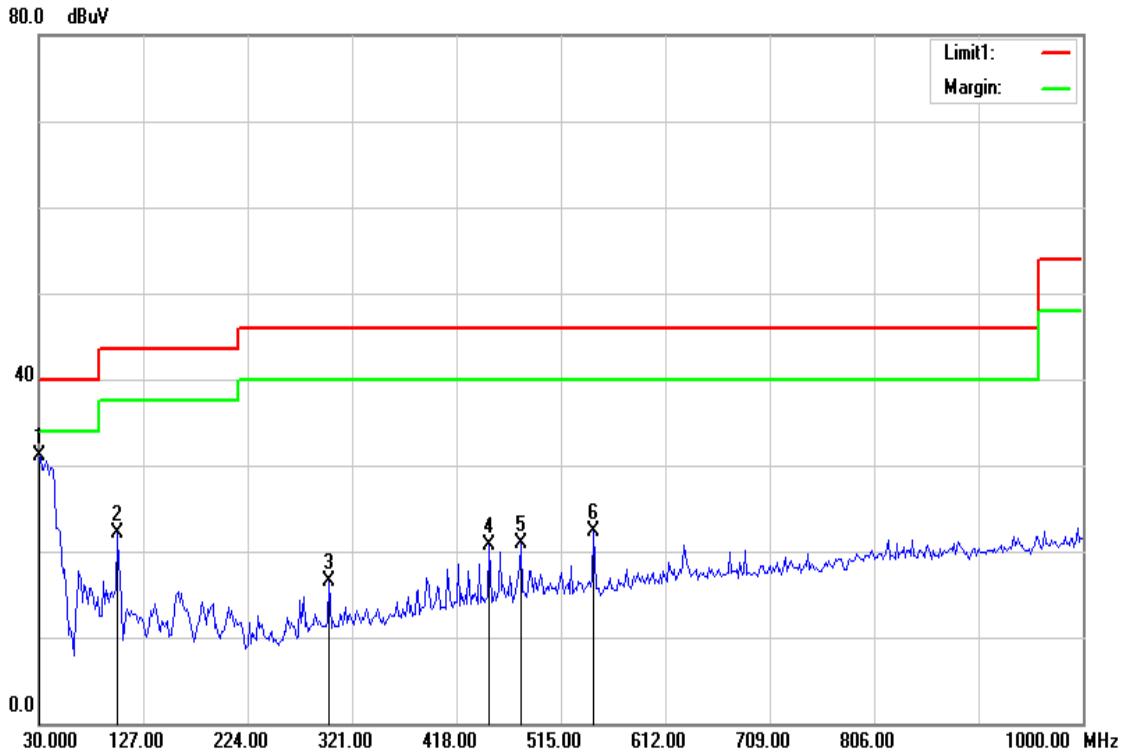

Frequency (MHz)	Reading (dBuV)	Correction Factor (dB/m)	Result (dBuV/m)	Limit (dBuV/m)	Margin (dB)	Remark	Ant. Pol. (H/V)
31.6167	52.81	-21.64	31.17	40.00	-8.83	Peak	V
102.7500	53.29	-31.23	22.06	43.50	-21.44	Peak	V
299.9833	44.19	-27.73	16.46	46.00	-29.54	Peak	V
448.7167	44.97	-24.24	20.73	46.00	-25.27	Peak	V
477.8167	44.68	-23.78	20.90	46.00	-25.10	Peak	V
545.7167	45.12	-22.84	22.28	46.00	-23.72	Peak	V

Remark:

1. Measuring frequencies from 30 MHz to the 1GHz.
2. Radiated emissions measured in frequency range from 30 MHz to 1000MHz were made with an instrument using peak/quasi-peak detector mode.
3. Quasi-peak test would be performed if the peak result were greater than the quasi-peak limit or as required by the applicant.
4. Measurements above show only up to 6 maximum emissions noted, or would be lesser, with " N/A " remark, if no specific emissions from the EUT are recorded (ie: margin>20dB from the applicable limit) and considered that's already beyond the background noise floor.
5. Margin (dB) = Result (dBuV/m) – Limit (dBuV/m).

Operation Mode: Normal Link

Test Date: July 21, 2015

Temperature: 27°C

Tested by: Jason Lu

Humidity: 53% RH

Polarity: Hor.

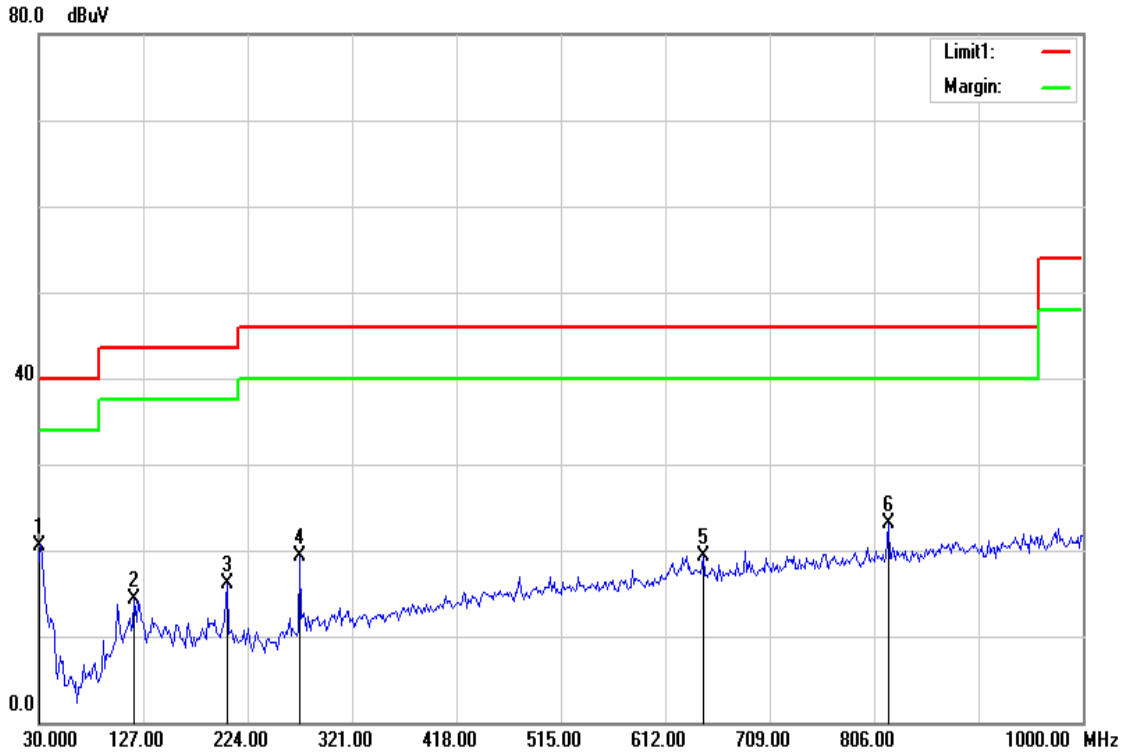

Frequency (MHz)	Reading (dBuV)	Correction Factor (dB/m)	Result (dBuV/m)	Limit (dBuV/m)	Margin (dB)	Remark	Ant. Pol. (H/V)
31.6167	42.24	-21.64	20.60	40.00	-19.40	peak	H
118.9167	42.78	-28.44	14.34	43.50	-29.16	peak	H
204.6000	45.18	-29.01	16.17	43.50	-27.33	peak	H
272.5000	47.53	-28.16	19.37	46.00	-26.63	peak	H
647.5667	40.09	-20.79	19.30	46.00	-26.70	peak	H
818.9333	41.74	-18.71	23.03	46.00	-22.97	peak	H

Remark:

1. Measuring frequencies from 30 MHz to the 1GHz.
2. Radiated emissions measured in frequency range from 30 MHz to 1000MHz were made with an instrument using peak/quasi-peak detector mode.
3. Quasi-peak test would be performed if the peak result were greater than the quasi-peak limit or as required by the applicant.
4. Measurements above show only up to 6 maximum emissions noted, or would be lesser, with " N/A " remark, if no specific emissions from the EUT are recorded (ie: margin>20dB from the applicable limit) and considered that's already beyond the background noise floor.
5. Margin (dB) = Result (dBuV/m) – Limit (dBuV/m).

Above 1 GHz

GFSK / TX / CH Low

Polarity: Vertical

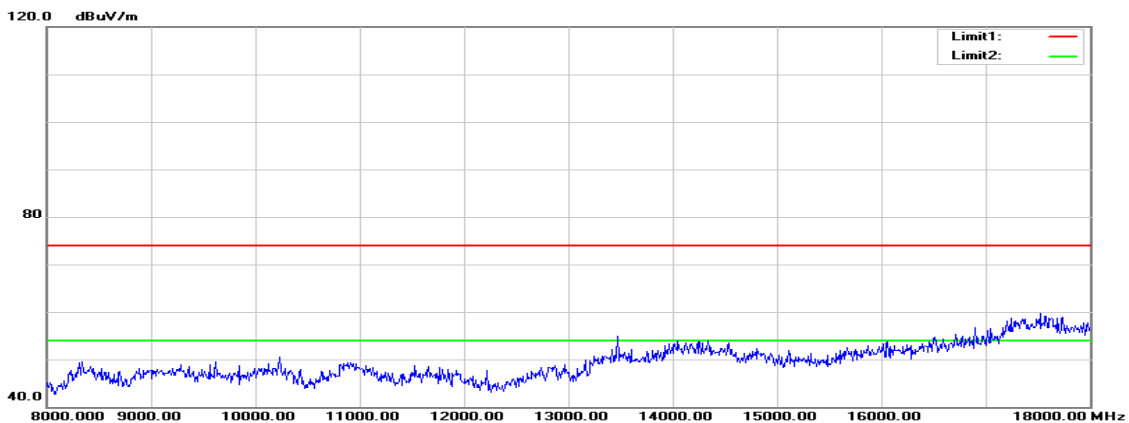
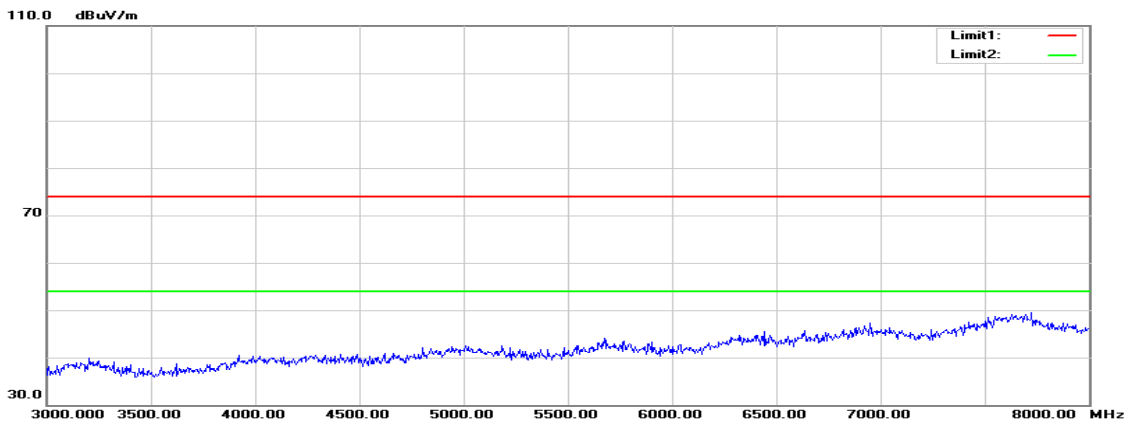
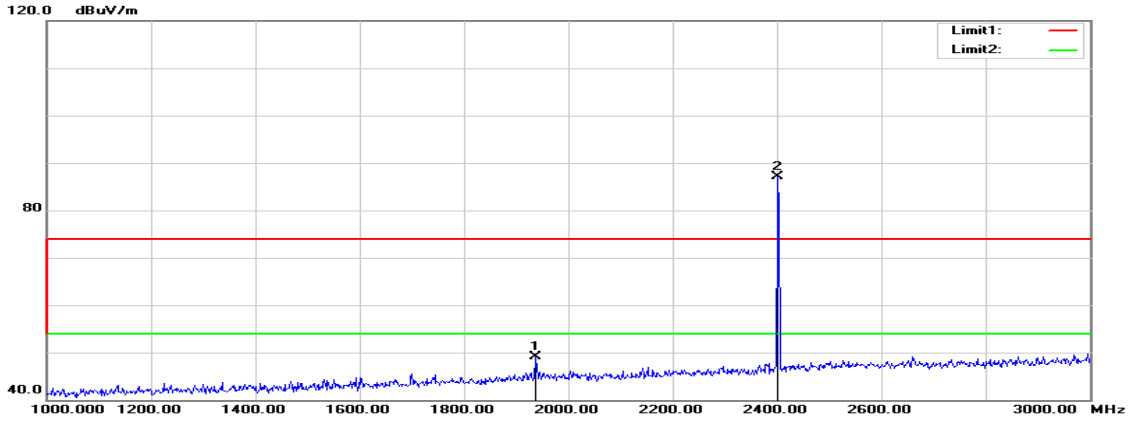

Polarity: Horizontal

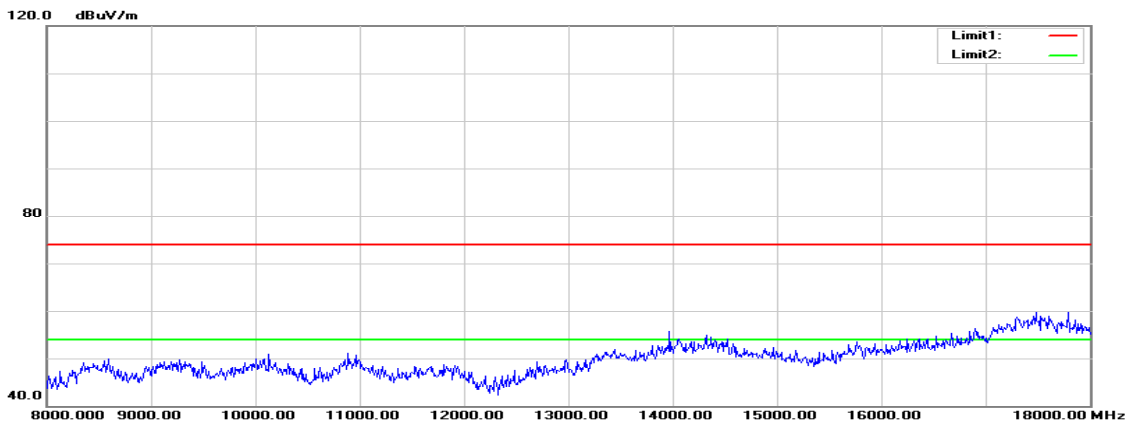
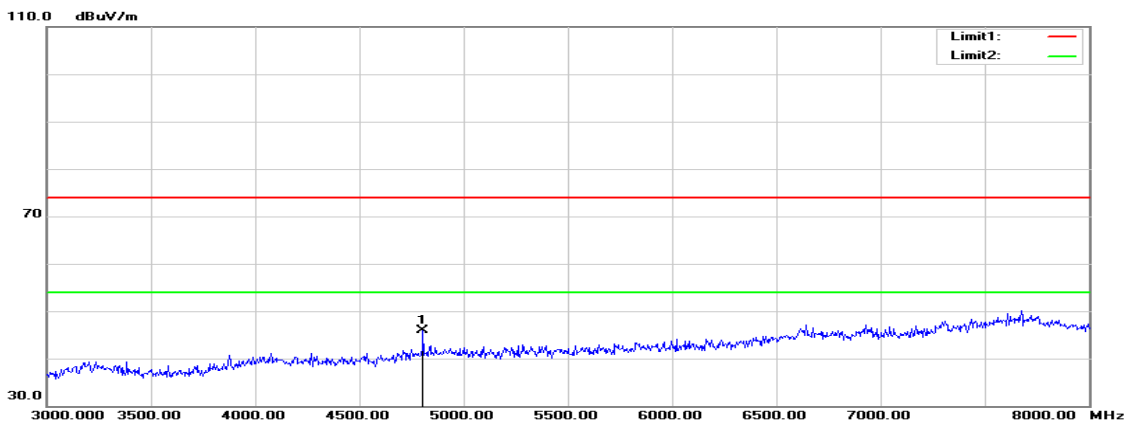
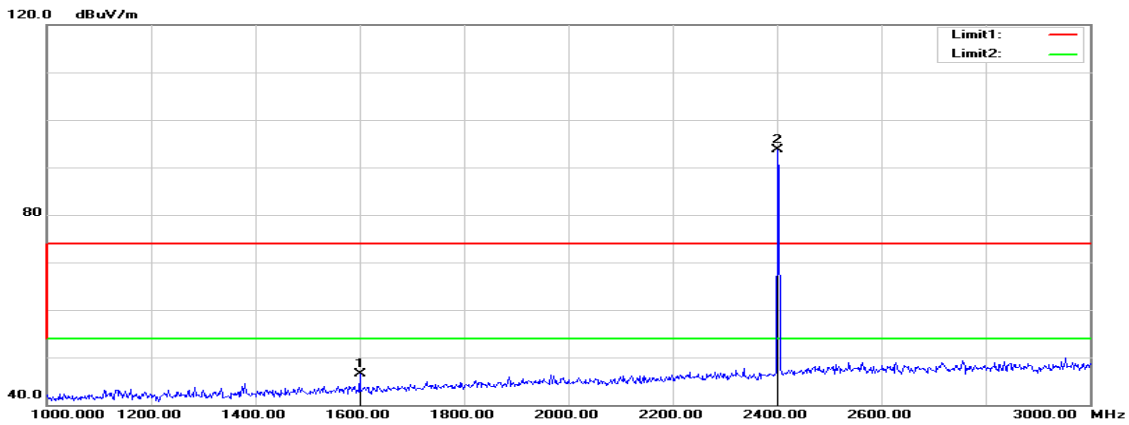

Operation Mode: GFSK / TX / CH Low **Test Date:** July 21, 2015
Temperature: 27°C **Tested by:** Jason Lu
Humidity: 53 % RH **Polarity:** Ver. / Hor.

Frequency (MHz)	Reading (dBuV)	Correction (dB/m)	Result (dBuV/m)	Limit (dBuV/m)	Margin (dB)	Remark	Ant.Pol. (H/V)
1936.000	53.07	-3.93	49.14	74.00	-24.86	peak	V
N/A							
1600.000	52.15	-5.67	46.48	74.00	-27.52	peak	H
4805.000	40.77	5.05	45.82	74.00	-28.18	peak	H
N/A							

Remark:

1. Measuring frequencies from 1 GHz to the 10th harmonic of highest fundamental frequency.
2. Radiated emissions measured in frequency above 1000MHz were made with an instrument using peak/average detector mode.
3. Average test would be performed if the peak result were greater than the average limit or as required by the applicant.
4. Data of measurement within this frequency range shown " --- " in the table above means the reading of emissions are attenuated more than 20dB below the permissible limits or the field strength is too small to be measured.
5. Measurements above show only up to 6 maximum emissions noted, or would be lesser, with " N/A " remark, if no specific emissions from the EUT are recorded (ie: margin>20dB from the applicable limit) and considered that's already beyond the background noise floor.
6. Margin (dB) = Remark result (dBuV/m) – Average limit (dBuV/m).

GFSK / TX / CH Mid

Polarity: Vertical

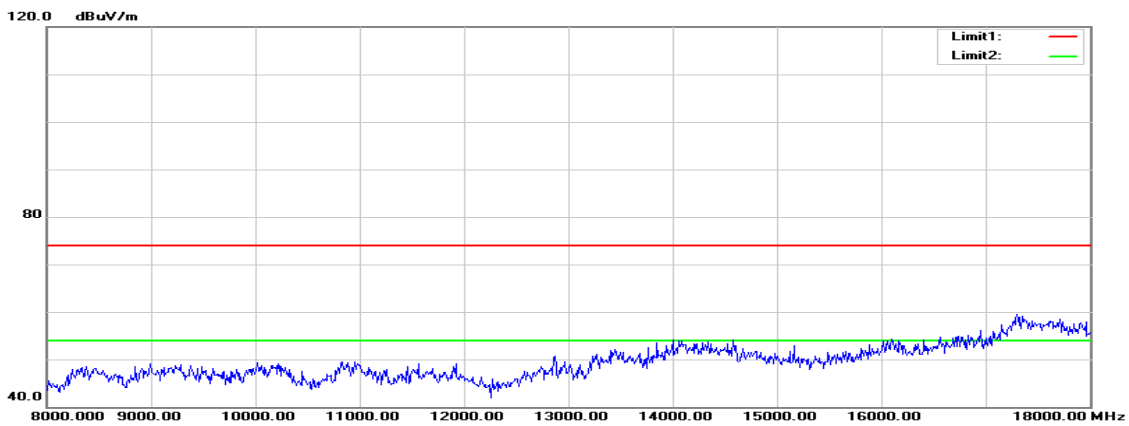
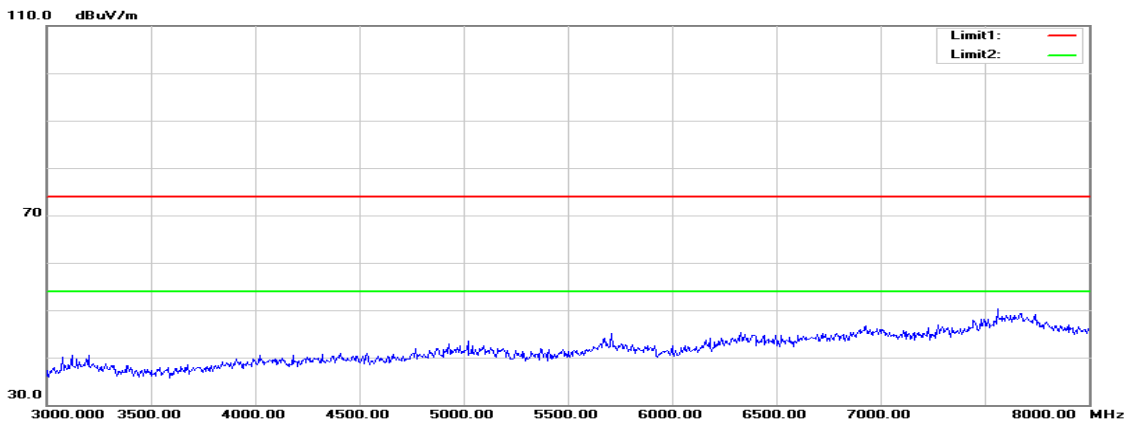
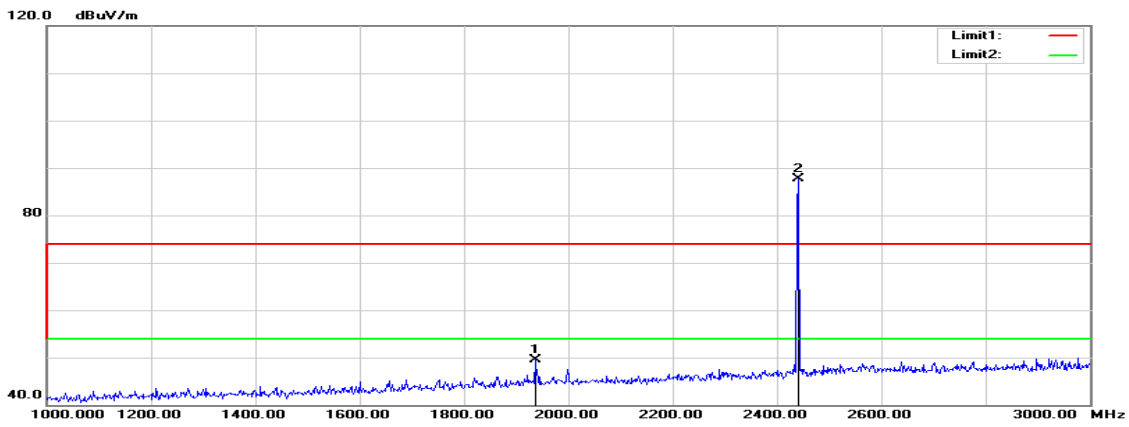

Polarity: Horizontal

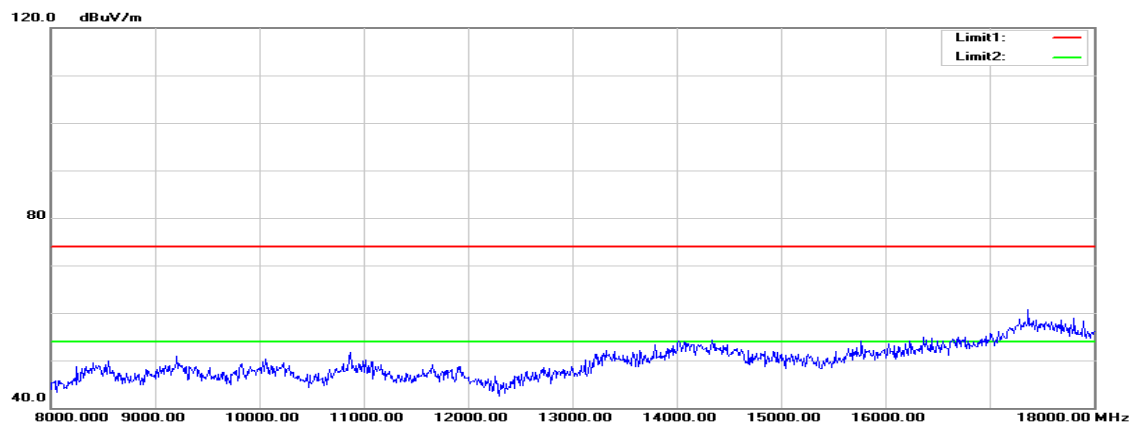
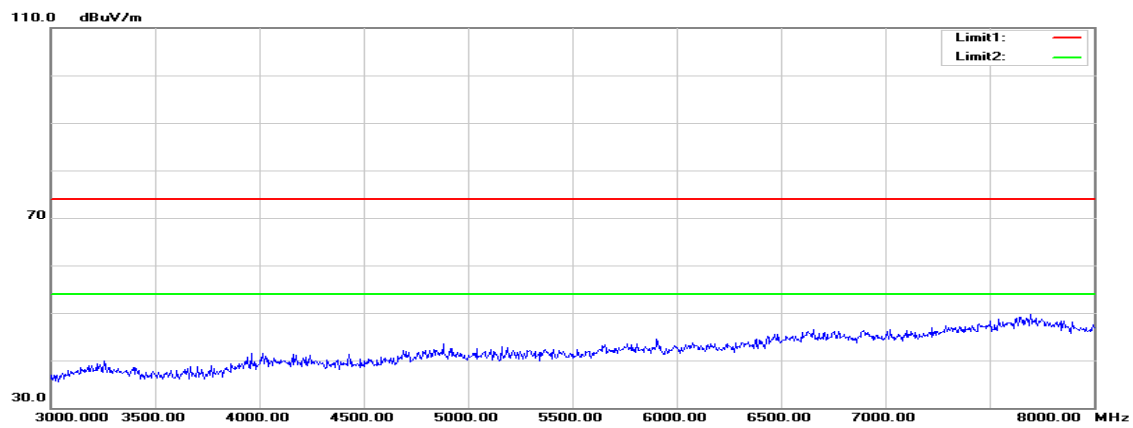
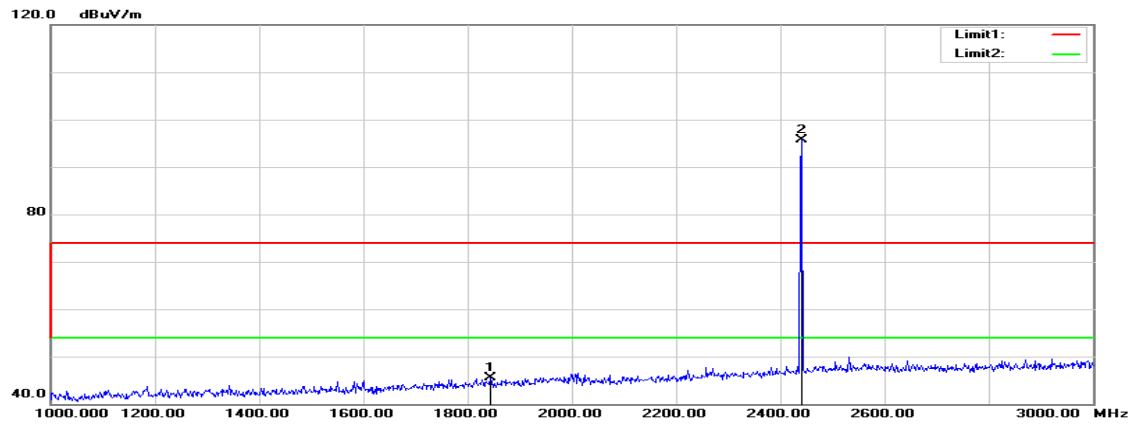

Operation Mode: GFSK / TX / CH Mid **Test Date:** July 21, 2015
Temperature: 27°C **Tested by:** Jason Lu
Humidity: 53 % RH **Polarity:** Ver. / Hor.

Frequency (MHz)	Reading (dBuV)	Correction (dB/m)	Result (dBuV/m)	Limit (dBuV/m)	Margin (dB)	Remark	Ant.Pol. (H/V)
1936.000	53.41	-3.93	49.48	74.00	-24.52	peak	V
N/A							
1844.000	49.98	-4.41	45.57	74.00	-28.43	peak	H
N/A							

Remark:

1. *Measuring frequencies from 1 GHz to the 10th harmonic of highest fundamental frequency.*
2. *Radiated emissions measured in frequency above 1000MHz were made with an instrument using peak/average detector mode.*
3. *Average test would be performed if the peak result were greater than the average limit or as required by the applicant.*
4. *Data of measurement within this frequency range shown " --- " in the table above means the reading of emissions are attenuated more than 20dB below the permissible limits or the field strength is too small to be measured.*
5. *Measurements above show only up to 6 maximum emissions noted, or would be lesser, with " N/A " remark, if no specific emissions from the EUT are recorded (ie: margin>20dB from the applicable limit) and considered that's already beyond the background noise floor.*
6. *Margin (dB) = Remark result (dBuV/m) – Average limit (dBuV/m).*

GFSK / TX / CH High

Polarity: Vertical

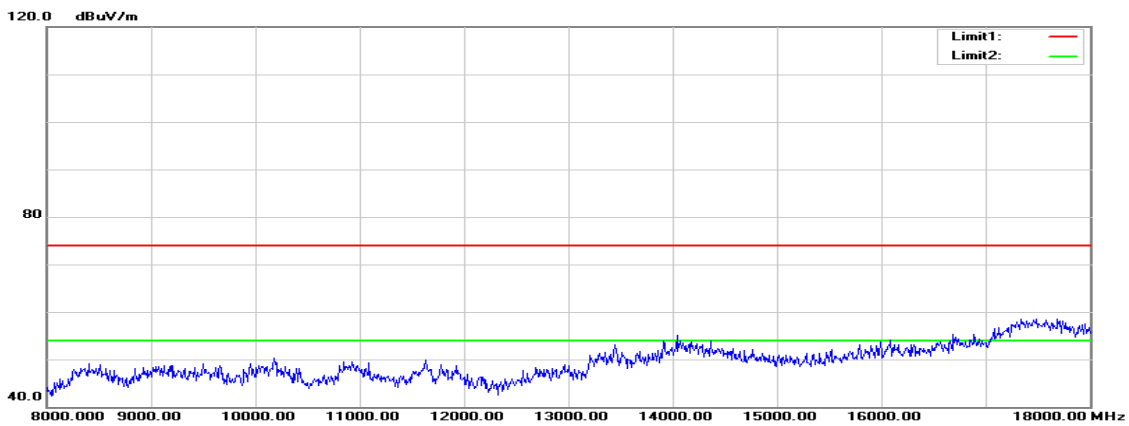
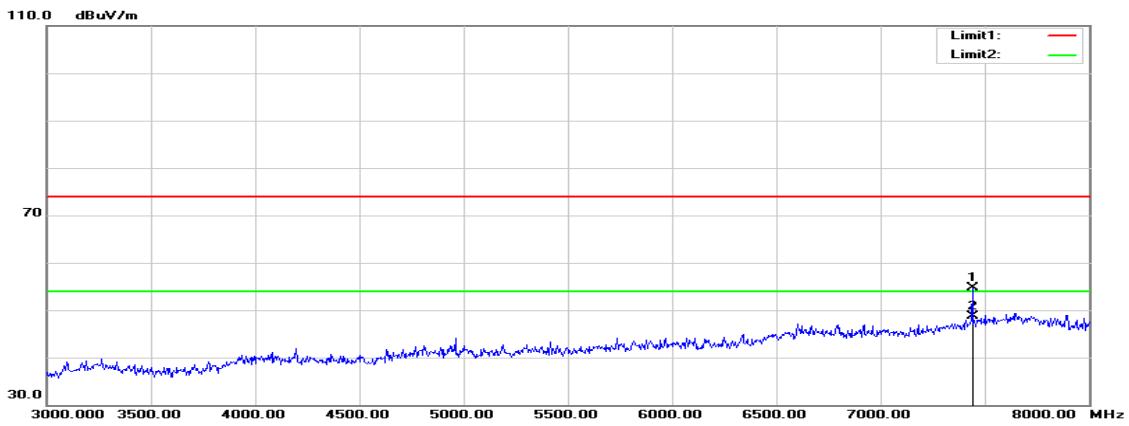
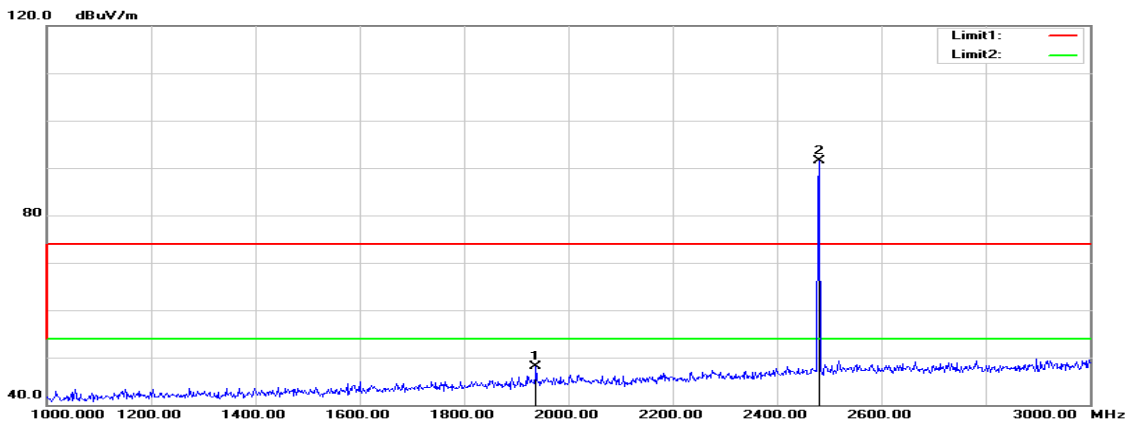

Polarity: Horizontal

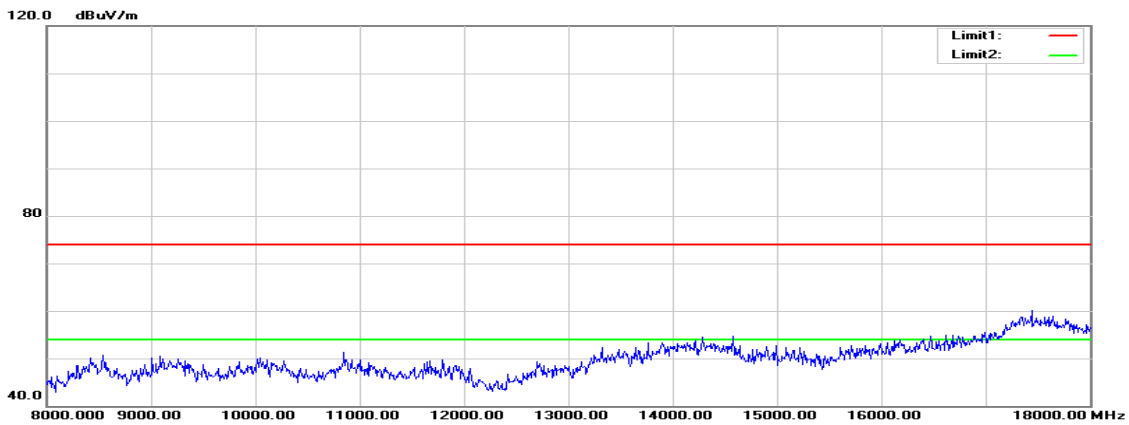
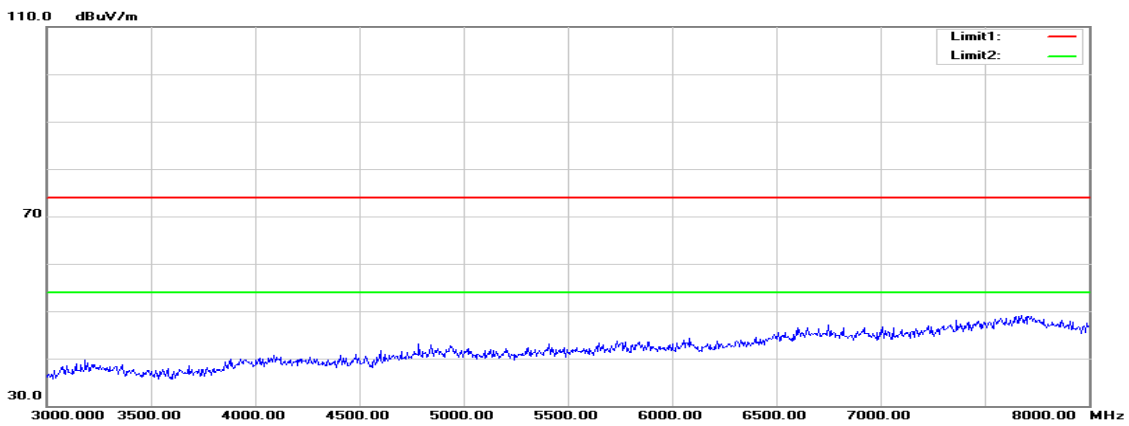
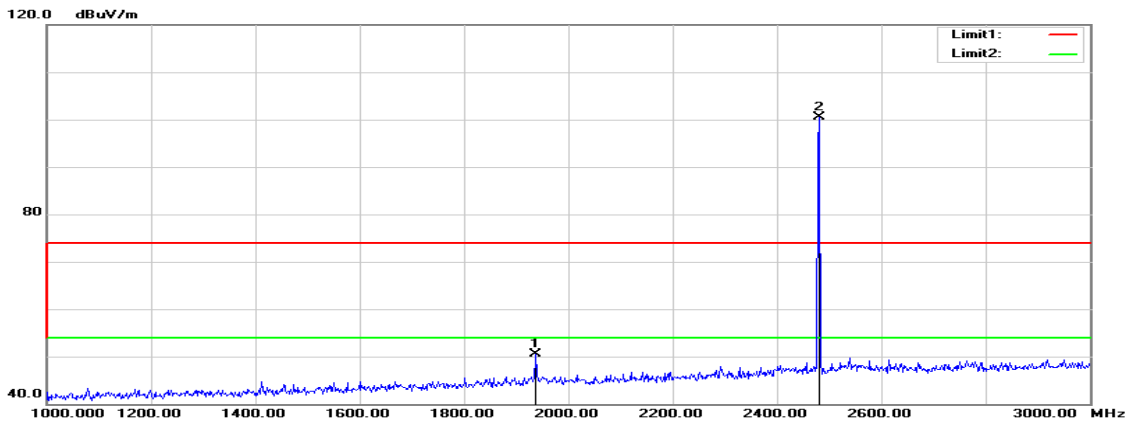

Operation Mode: GFSK / TX / CH High **Test Date:** July 21, 2015
Temperature: 27°C **Tested by:** Jason Lu
Humidity: 53 % RH **Polarity:** Ver. / Hor.

Frequency (MHz)	Reading (dBuV)	Correction (dB/m)	Result (dBuV/m)	Limit (dBuV/m)	Margin (dB)	Remark	Ant.Pol. (H/V)
1938.000	52.08	-3.92	48.16	74.00	-25.84	peak	V
7440.000	41.37	13.33	54.70	74.00	-19.30	peak	V
7440.000	35.45	13.33	48.78	54.00	-5.22	AVG	V
N/A							
1938.000	54.34	-3.92	50.42	74.00	-23.58	peak	H
N/A							

Remark:

1. Measuring frequencies from 1 GHz to the 10th harmonic of highest fundamental frequency.
2. Radiated emissions measured in frequency above 1000MHz were made with an instrument using peak/average detector mode.
3. Average test would be performed if the peak result were greater than the average limit or as required by the applicant.
4. Data of measurement within this frequency range shown " --- " in the table above means the reading of emissions are attenuated more than 20dB below the permissible limits or the field strength is too small to be measured.
5. Measurements above show only up to 6 maximum emissions noted, or would be lesser, with " N/A " remark, if no specific emissions from the EUT are recorded (ie: margin>20dB from the applicable limit) and considered that's already beyond the background noise floor.
6. Margin (dB) = Remark result (dBuV/m) – Average limit (dBuV/m).

7.9 POWERLINE CONDUCTED EMISSIONS

LIMIT

According to §15.207(a) & RSS-Gen §7.2.4, except as shown in paragraphs (b) and (c) of this section, for an intentional radiator that is designed to be connected to the public utility (AC) power line, the radio frequency voltage that is conducted back onto the AC power line on any frequency or frequencies within the band 150 kHz to 30 MHz shall not exceed the limits in the following table, as measured using a 50 μ H/50 ohms line impedance stabilization network (LISN). Compliance with the provisions of this paragraph shall be based on the measurement of the radio frequency voltage between each power line and ground at the power terminal. The lower limit applies at the boundary between the frequency ranges.

Frequency Range (MHz)	Limits (dB μ V)	
	Quasi-peak	Average
0.15 to 0.50	66 to 56*	56 to 46*
0.50 to 5	56	46
5 to 30	60	50

Test Configuration

See test photographs attached in Appendix II for the actual connections between EUT and support equipment.

TEST PROCEDURE

1. The EUT was placed on a table, which is 0.8m above ground plane.
2. Maximum procedure was performed on the six highest emissions to ensure EUT compliance.
3. Repeat above procedures until all frequency measured were complete.

TEST RESULTS

The initial step in collecting conducted data is a spectrum analyzer peak scan of the measurement range. Significant peaks are then marked as shown on the following data page, and these signals are then quasi-peaked.

Test Data

Operation Mode: Normal Link **Test Date:** August 5, 2015
Temperature: 26°C **Tested by:** David Shu
Humidity: 60% RH

Freq. (MHz)	QP Reading (dBuV)	AV Reading (dBuV)	Corr. factor (dB/m)	QP Result (dBuV/m)	AV Result (dBuV/m)	QP Limit (dBuV)	AV Limit (dBuV)	QP Margin (dB)	AV Margin (dB)	Note
0.1527	56.41	50.68	0.09	56.50	50.77	65.85	55.85	-9.35	-5.08	L1
0.1780	51.22	44.62	0.09	51.31	44.71	64.58	54.58	-13.27	-9.87	L1
0.2009	49.77	43.96	0.09	49.86	44.05	63.57	53.57	-13.71	-9.52	L1
0.2732	36.86	27.35	0.09	36.95	27.44	61.02	51.02	-24.07	-23.58	L1
0.3050	41.12	35.97	0.10	41.22	36.07	60.11	50.11	-18.89	-14.04	L1
0.4398	44.75	31.69	0.10	44.85	31.79	57.07	47.07	-12.22	-15.28	L1
0.1601	52.59	44.32	0.09	52.68	44.41	65.46	55.46	-12.78	-11.05	L2
0.1826	50.30	42.42	0.09	50.39	42.51	64.37	54.37	-13.98	-11.86	L2
0.1964	48.75	41.69	0.09	48.84	41.78	63.76	53.76	-14.92	-11.98	L2
0.2350	39.73	30.27	0.09	39.82	30.36	62.27	52.27	-22.45	-21.91	L2
0.4402	44.67	31.78	0.09	44.76	31.87	57.06	47.06	-12.30	-15.19	L2
0.7541	35.27	28.02	0.10	35.37	28.12	56.00	46.00	-20.63	-17.88	L2

Remark:

1. Measuring frequencies from 0.15 MHz to 30MHz.
2. The emissions measured in frequency range from 0.15 MHz to 30MHz were made with an instrument using Quasi-peak detector and average detector.
3. The IF bandwidth of SPA between 0.15MHz and 30MHz was 10 kHz; the IF bandwidth of Test Receiver between 0.15MHz and 30MHz was 9 kHz;
4. L1 = Line One (Live Line) / L2 = Line Two (Neutral Line)

Test Plots

Conducted emissions (Line 1)

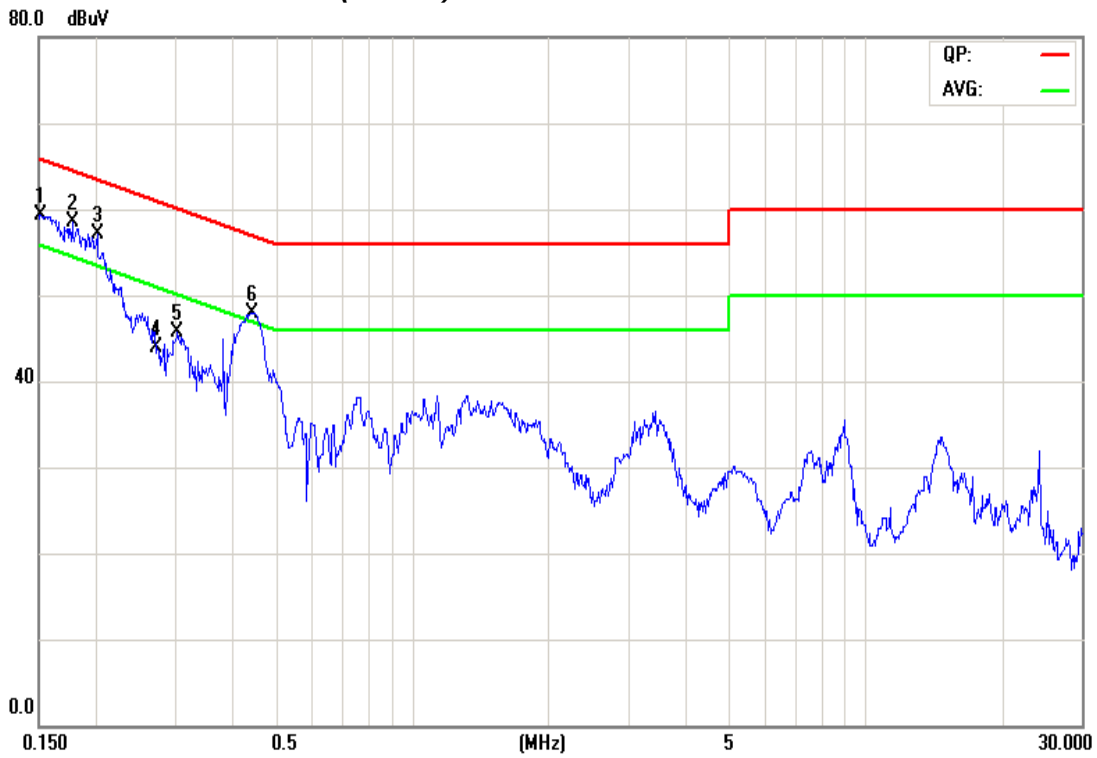

Conducted emissions (Line 2)

