



# FCC PART 15B, CLASS B

## TEST REPORT

For

### Shen Zhen Autopro Technology CO., LTD

BLDG H2, Area A, HongFa Technology Industrial Zone, ShiYan Town, BaoAn District, ShenZhen, Guangdong, China

**FCC ID: VUDAUTOPRO2013**

<b>Report Type:</b> Original Report	<b>Product Type:</b> Android Box
<b>Test Engineer:</b> Ares Liu	<i>Ares Liu</i>
<b>Report Number:</b> R2DG130201005-00B	
<b>Report Date:</b> 2013-03-25	
<b>Reviewed By:</b> RF Leader	Ivan Cao <i>Ivan Cao</i>
<b>Test Laboratory:</b>	Bay Area Compliance Laboratories Corp. (Dongguan) No.69 Pulongcun, Puxinhu Industrial Zone, Tangxia, Dongguan, Guangdong, China Tel: +86-769-86858888 Fax: +86-769-86858891 <a href="http://www.baclcorp.com.cn">www.baclcorp.com.cn</a>

Note: This test report is prepared for the customer shown above and for the device described herein. It may not be duplicated or used in part without prior written consent from Bay Area Compliance Laboratories Corp. This report must not be used by the customer to claim product certification, approval, or endorsement by NVLAP\*, or any agency of the Federal Government.

\* This report may contain data that are not covered by the NVLAP accreditation and shall be marked with an asterisk "★" (Rev.2)

**TABLE OF CONTENTS**

**GENERAL INFORMATION.....3**  
    PRODUCT DESCRIPTION FOR EQUIPMENT UNDER TEST (EUT) .....3  
    OBJECTIVE .....3  
    RELATED SUBMITTAL(S)/GRANT(S).....3  
    TEST FACILITY .....3

**SYSTEM TEST CONFIGURATION.....4**  
    JUSTIFICATION .....4  
    EUT EXERCISE SOFTWARE .....4  
    EQUIPMENT MODIFICATIONS .....4  
    SUPPORT EQUIPMENT LIST AND DETAILS .....4  
    EXTERNAL CABLE.....4  
    BLOCK DIAGRAM OF TEST SETUP .....5

**SUMMARY OF TEST RESULTS .....6**

**FCC §15.109 - RADIATED EMISSIONS .....7**  
    MEASUREMENT UNCERTAINTY .....7  
    EUT SETUP .....7  
    EMI TEST RECEIVER SETUP.....8  
    TEST PROCEDURE .....8  
    CORRECTED AMPLITUDE & MARGIN CALCULATION .....9  
    TEST EQUIPMENT LIST AND DETAILS.....9  
    TEST RESULTS SUMMARY .....9  
    TEST DATA .....9

## GENERAL INFORMATION

---

### Product Description for Equipment under Test (EUT)

The *Shen Zhen Autopro Technology CO., LTD's* product, model number: MAD11(FCC ID: VUDAUTOPRO2013) ("EUT") in this report is a *Android Box*, which was measured approximately: 16.4cm (L) x 10.9 cm (W) x2.6cm (H), rated input voltage: DC 12 V from Battery.

*\* All measurement and test data in this report was gathered from production sample serial number: 130201005 (Assigned by BACL, Dongguan). The EUT was received on 2013-02-25.*

### Objective

This report is prepared on behalf of *Shen Zhen Autopro Technology CO., LTD* in accordance with Part 2, Subpart J, Part 15, Subparts A and B of the Federal Communication Commissions rules.

The objective of the manufacturer is to determine compliance with FCC Part 15B, Class B.

### Related Submittal(s)/Grant(s)

FCC Part 15C DTS submissions with FCC ID: VUDAUTOPRO2013.

### Test Facility

The Test site used by Bay Area Compliance Laboratories Corp. (Dongguan) to collect test data is located on the No.69 Pulongcun, Puxinhu Industrial Zone, Tangxia, Dongguan, Guangdong, China

Test site at Bay Area Compliance Laboratories Corp. (Dongguan) has been fully described in reports submitted to the Federal Communication Commission (FCC). The details of these reports have been found to be in compliance with the requirements of Section 2.948 of the FCC Rules on February 02, 2012. The facility also complies with the radiated and AC line conducted test site criteria set forth in ANSI C63.4-2003.

The Federal Communications Commission has the reports on file and is listed under FCC Registration No.: 273710. The test site has been approved by the FCC for public use and is listed in the FCC Public Access Link (PAL) database.

Additionally, Bay Area Compliance Laboratories Corp. (Dongguan) is an ISO/IEC 17025 accredited laboratory, and is accredited by National Voluntary Laboratory Accredited Program (Lab Code 500069-0).



The current scope of accreditations can be found at <http://ts.nist.gov/standards/scopes/5000690.htm>

## SYSTEM TEST CONFIGURATION

---

### Justification

The system was configured for testing in a typical fashion (as normally used by a typical user).

### EUT Exercise Software

No EUT exercise software was used.

### Equipment Modifications

No modification was made to the EUT.

### Support Equipment List and Details

Manufacturer	Description	Model	Serial Number
DELL	Monitor	U3011t	CN-OPH5NY-74445-16T-290L
Kinston	USB Flash Disk	Data Traveler 4G	N/A
Kinston	SD Card	UHS-4G	N/A

### External Cable

Cable Description	Length (m)	From Port	To
shielded detachable HDMI cable	1.5	EUT	Monitor
Detachable AV cable	2.0	EUT	Monitor

**Block Diagram of Test Setup**

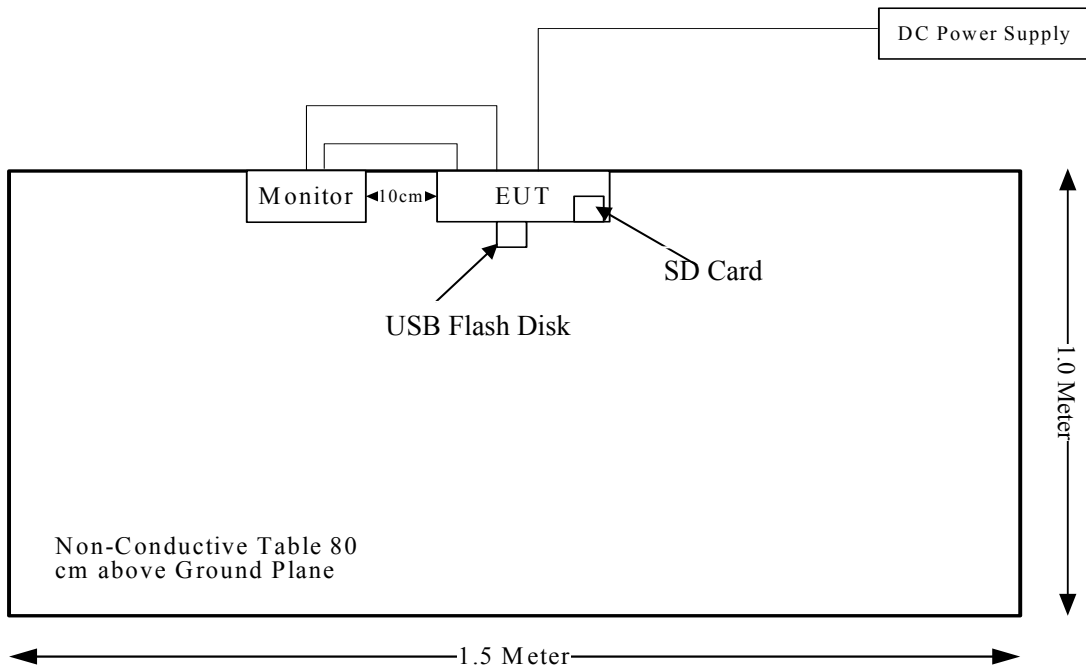

**SUMMARY OF TEST RESULTS**

<b>FCC Rules</b>	<b>Description of Test</b>	<b>Results</b>
§15.107	AC Line Conducted Emissions	Not Applicable*
§15.109	Radiated Emissions	Compliance

Not Applicable\*:the EUT power by DC 12V from battery.

## FCC §15.109 - RADIATED EMISSIONS

### Measurement Uncertainty

Compliance or non-compliance with a disturbance limit shall be determined in the following manner:

If  $U_{lab}$  is less than or equal to  $U_{cispr}$  of Table 2, then:

- compliance is deemed to occur if no measured disturbance level exceeds the disturbance limit;
- non-compliance is deemed to occur if any measured disturbance level exceeds the disturbance limit.

If  $U_{lab}$  is greater than  $U_{cispr}$  of Table 1, then:

- compliance is deemed to occur if no measured disturbance level, increased by  $(U_{lab} - U_{cispr})$ , exceeds the disturbance limit;
- non-compliance is deemed to occur if any measured disturbance level, increased by  $(U_{lab} - U_{cispr})$ , exceeds the disturbance limit.

Based on CISPR 16-4-2: 2011, measurement uncertainty of radiated emission at a distance of 3m at Bay Area Compliance Laboratories Corp. (Dongguan) is:

- 30M~200MHz: 5.0 dB
- 200M~1GHz: 6.2 dB
- 1G~6GHz: 4.45 dB
- 6G~18GHz: 5.23 dB

Table 2 – Values of  $U_{cispr}$

Measurement	$U_{cispr}$
Radiated disturbance (electric field strength at an OATS or in a SAC) (30 MHz to 1000 MHz)	6.3 dB
Radiated disturbance (electric field strength in a FAR) (1 GHz to 6 GHz)	5.2 dB
Radiated disturbance (electric field strength in a FAR) (6 GHz to 18 GHz)	5.5 dB

### EUT Setup

Below 1 GHz:

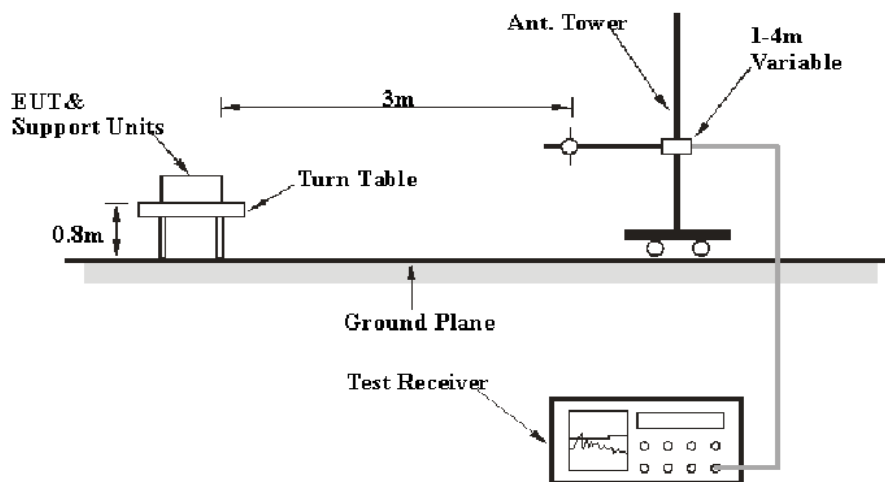

**Above 1 G:**

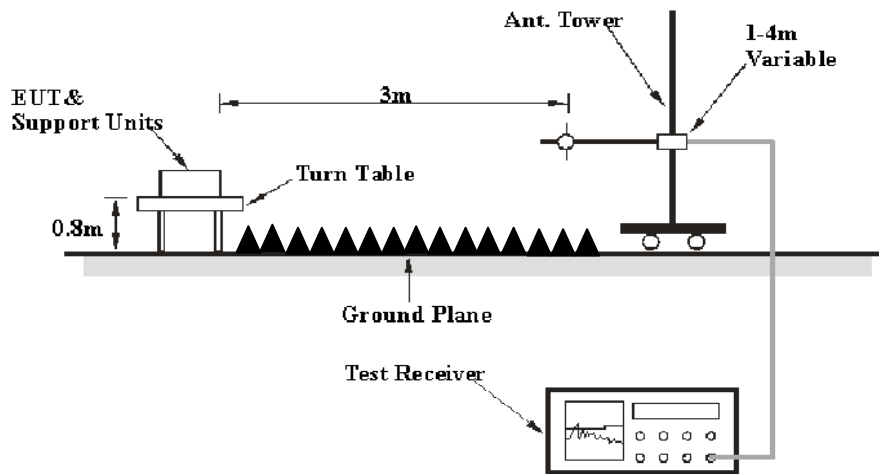

The radiated emission tests were performed in the 3 meters chamber test site, using the setup accordance with the ANSI C63.4-2003. The specification used was the FCC Part 15.109, Class B limits.

The external I/O cables were draped along the test table and formed a bundle 30 to 40 cm long in the middle.

The EUT connected to a DC power battery.

**EMI Test Receiver Setup**

According to FCC 15.33 requirements, the system was measured from 30 MHz to 6 GHz.

During the radiated emission test, the EMI test receiver was set with the following configurations:

<i>Frequency Range</i>	<i>RBW</i>	<i>Video B/W</i>	<i>Detector</i>
30 MHz – 1000 MHz	120 kHz	300 kHz	QP
Above 1 GHz	1MHz	3 MHz	Peak
Above 1 GHz	1MHz	10 Hz	Ave

**Test Procedure**

For the radiated emissions test, the EUT was connected to the first DC floor outlet and the other support equipments were connected to the second AC floor outlet.

Maximizing procedure was performed on the highest emissions to ensure that the EUT complied with all installation combinations.

The data was recorded in Quasi-peak detection mode for 30 MHz to 1 GHz, Peak and average detection mode above 1 GHz.



## Corrected Amplitude & Margin Calculation

The Corrected Amplitude is calculated by adding the Antenna Loss and Cable Loss, and subtracting the Amplifier Gain from the Meter Reading. The basic equation is as follows:

$$\text{Corrected Amplitude} = \text{Meter Reading} + \text{Antenna Loss} + \text{Cable Loss} - \text{Amplifier Gain}$$

The “**Margin**” column of the following data tables indicates the degree of compliance with the applicable limit. For example, a margin of 7dB means the emission is 7dB below the limit. The equation for margin calculation is as follows:

$$\text{Margin} = \text{Limit} - \text{Corrected Amplitude}$$

## Test Equipment List and Details

Manufacturer	Description	Model	Serial Number	Calibration Date	Calibration Due Date
Rohde & Schwarz	EMI Test Receiver	ESCI	100035	2012-05-14	2013-05-13
Sunol Sciences	Hybrid Antennas	JB3	A060611-1	2012-09-06	2013-09-05
HP	Pre-amplifier	8447E	2434A02181	2012-10-08	2013-10-07
R&S	Spectrum Analyzer	FSEM 30	DE31388	2013-03-15	2014-03-14
ETS-LINDGREN	Horn Antenna	3115	000 527 35	2012-09-06	2014-09-05
Mini-Circuit	Amplifier	ZVA-213-S+	054201245	2013-01-30	2014-01-29
Farad	Test Software	EZ-EMC	V1.1.4.2	N/A	N/A

\* **Statement of Traceability:** Bay Area Compliance Laboratories Corp. (Dongguan) attests that all calibrations have been performed in accordance to NVLAP requirements, traceable to National Primary Standards and International System of Units (SI).

## Test Results Summary

According to the data in the following table, the EUT complied with the FCC §15.109, Class B, with the worst margin reading of:

**1.13 dB at 400.5400 MHz in the Horizontal polarization USB Input & HDMI Output mode**

## Test Data

### Environmental Conditions

<b>Temperature:</b>	24.6 °C
<b>Relative Humidity:</b>	63 %
<b>ATM Pressure:</b>	100.8 kPa

*The testing was performed by Ares Liu on 2013-03-21.*

*EUT operating mode: Running*

**Below 1GHz**

**Mode: SD Card Input & AV Output**

**Horizontal:**

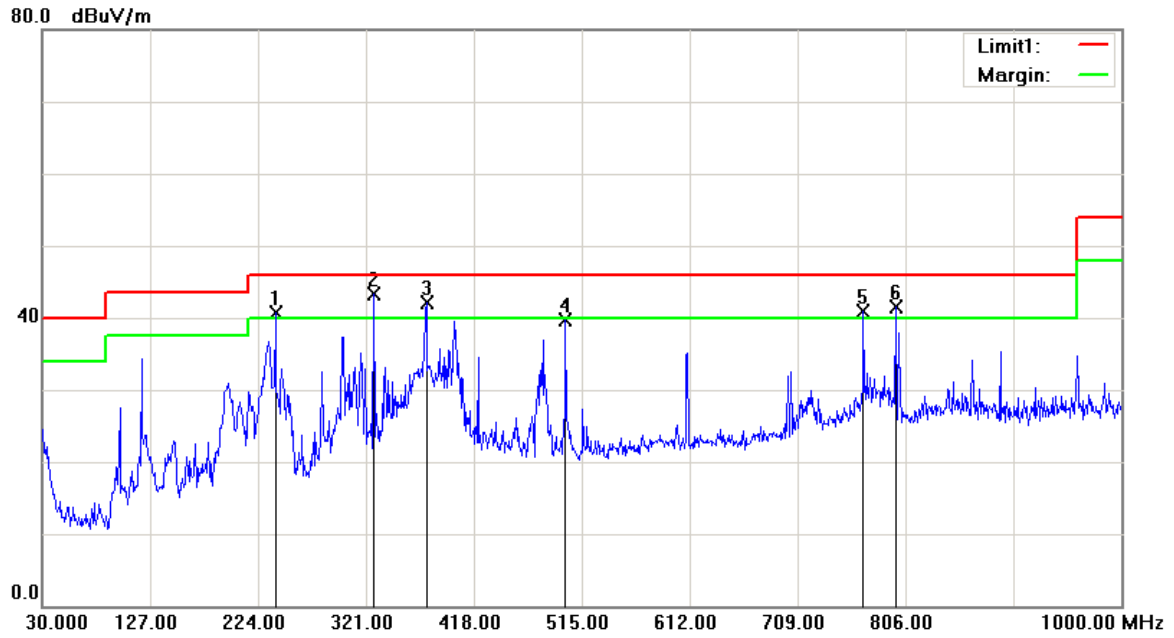

Frequency (MHz)	Receiver Reading (dBuV/m)	Detector (PK/QP/Av e)	Correction Factor (dB)	Cord. Amp. (dBuV/m)	Limit (dBuV/m)	Margin (dB)
239.5200	48.76	QP	-8.11	40.65	46.00	5.35
327.7900	48.95	QP	-5.62	43.33	46.00	2.67
375.3200	46.69	QP	-4.50	42.19	46.00	3.81
500.4500	41.90	QP	-2.27	39.63	46.00	6.37
768.1700	39.45	QP	1.38	40.83	46.00	5.17
797.2700	39.81	QP	1.71	41.52	46.00	4.48

**Vertical:**

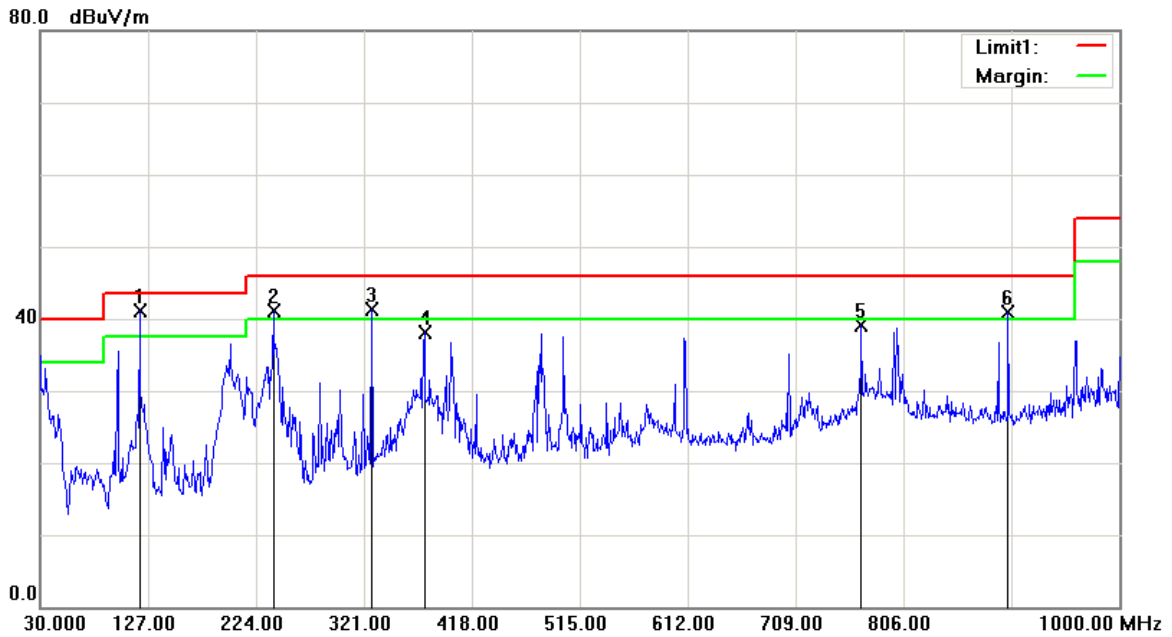

Frequency (MHz)	Receiver Reading (dBuV/m)	Detector (PK/QP/Av e)	Correction Factor (dB)	Cord. Amp. (dBuV/m)	Limit (dBuV/m)	Margin (dB)
119.2400	47.55	QP	-6.50	41.05	43.50	2.45
239.5200	49.14	QP	-8.11	41.03	46.00	4.97
327.7900	46.91	QP	-5.62	41.29	46.00	4.71
375.3200	42.52	QP	-4.50	38.02	46.00	7.98
768.1700	37.68	QP	1.38	39.06	46.00	6.94
900.0900	37.85	QP	3.13	40.98	46.00	5.02

**Mode: USB Input & AV Output**

**Horizontal:**

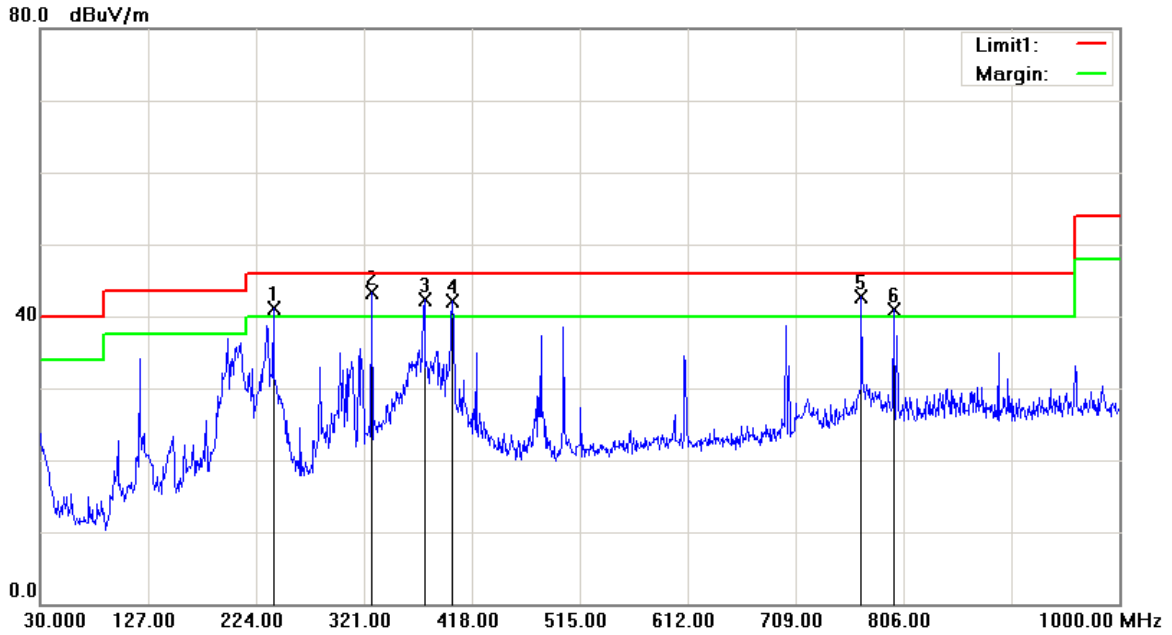

Frequency (MHz)	Receiver Reading (dBuV/m)	Detector (PK/QP/Av e)	Correction Factor (dB)	Cord. Amp. (dBuV/m)	Limit (dBuV/m)	Margin (dB)
239.5200	49.14	QP	-8.11	41.03	46.00	4.97
327.7900	48.98	QP	-5.62	43.36	46.00	2.64
375.3200	46.80	QP	-4.50	42.30	46.00	3.70
400.5400	46.27	QP	-4.09	42.18	46.00	3.82
768.1700	41.30	QP	1.38	42.68	46.00	3.32
797.2700	39.19	QP	1.71	40.90	46.00	5.10

**Vertical:**

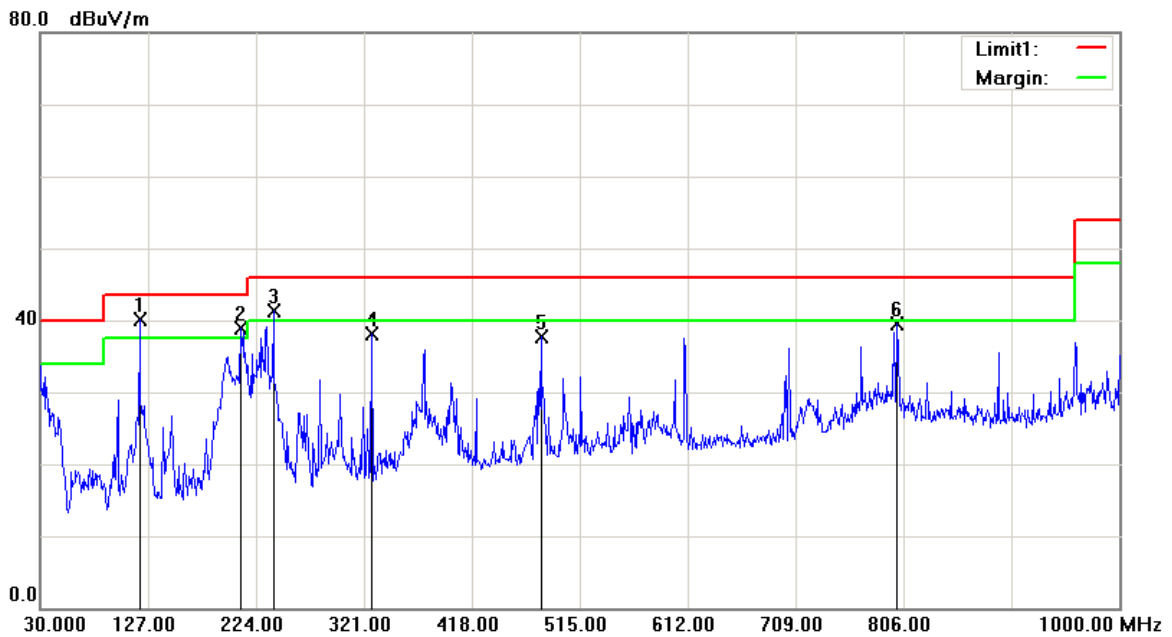

Frequency (MHz)	Receiver Reading (dBuV/m)	Detector (PK/QP/Av e)	Correction Factor (dB)	Cord. Amp. (dBuV/m)	Limit (dBuV/m)	Margin (dB)
119.2400	46.52	QP	-6.50	40.02	43.50	3.48
210.4200	48.01	QP	-9.08	38.93	43.50	4.57
239.5200	49.33	QP	-8.11	41.22	46.00	4.78
327.7900	43.64	QP	-5.62	38.02	46.00	7.98
480.0800	39.95	QP	-2.28	37.67	46.00	8.33
800.1800	37.72	QP	1.79	39.51	46.00	6.49

**Mode: SD Card Input & HDMI Output**

**Horizontal:**

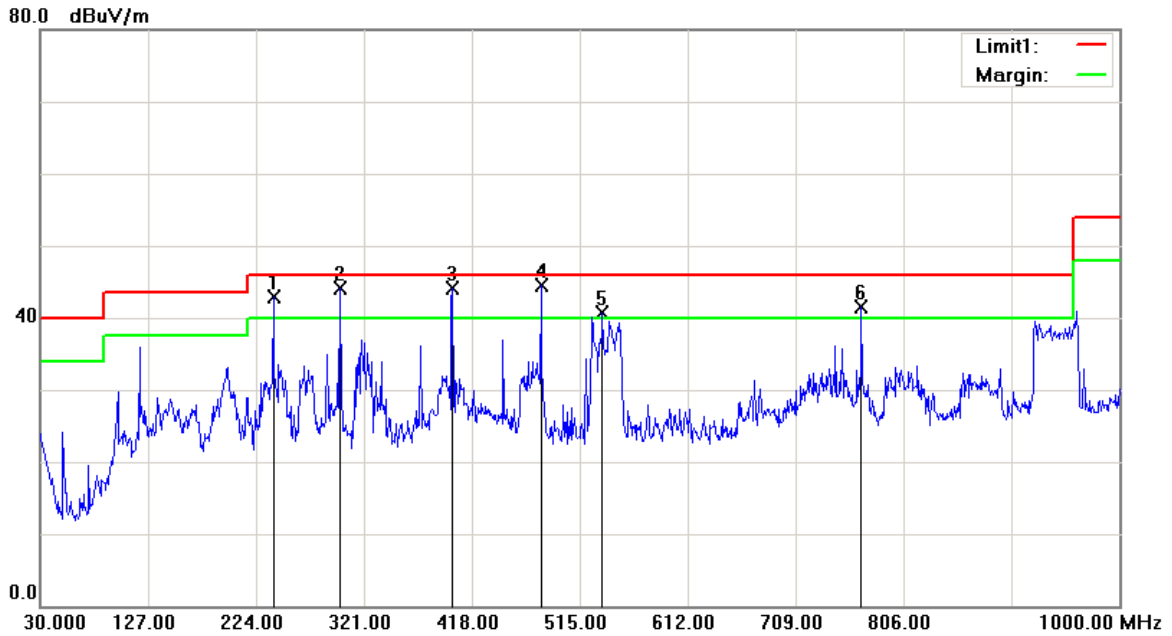

Frequency (MHz)	Receiver Reading (dBuV/m)	Detector (PK/QP/Av e)	Correction Factor (dB)	Cord. Amp. (dBuV/m)	Limit (dBuV/m)	Margin (dB)
239.5200	51.02	QP	-8.11	42.91	46.00	3.09
299.6600	50.32	QP	-6.20	44.12	46.00	1.88
400.5400	48.25	QP	-4.09	44.16	46.00	1.84
480.0800	46.78	QP	-2.28	44.50	46.00	1.50
535.3700	42.66	QP	-1.93	40.73	46.00	5.27
768.1700	40.04	QP	1.38	41.42	46.00	4.58

**Vertical:**

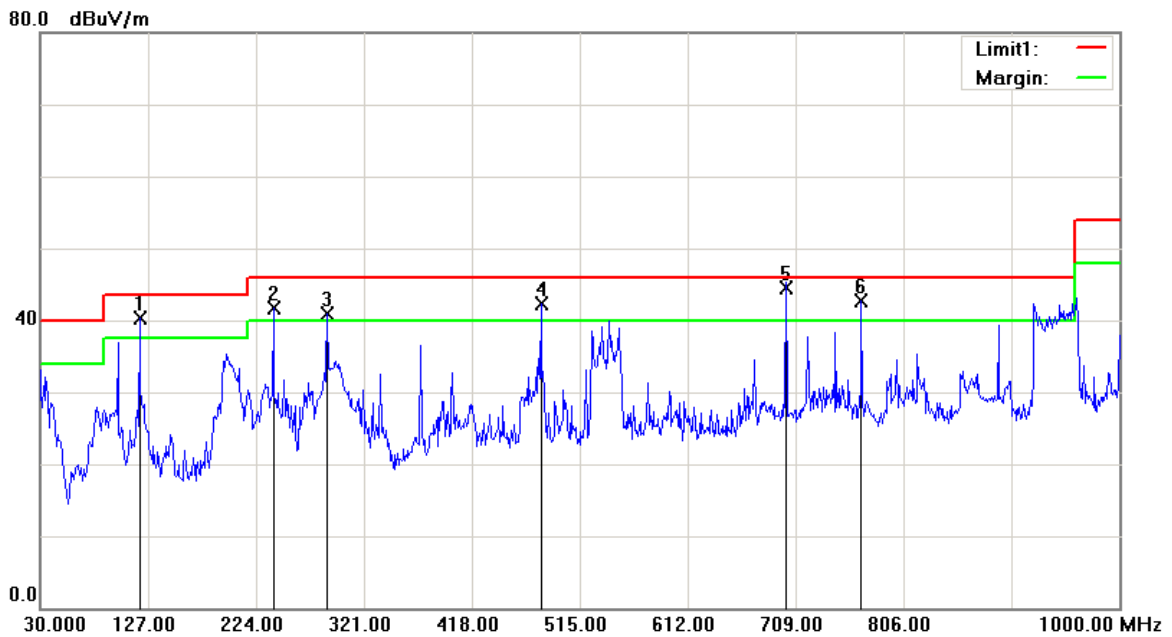

Frequency (MHz)	Receiver Reading (dBuV/m)	Detector (PK/QP/Av e)	Correction Factor (dB)	Cord. Amp. (dBuV/m)	Limit (dBuV/m)	Margin (dB)
119.2400	46.88	QP	-6.50	40.38	43.50	3.12
239.5200	49.86	QP	-8.11	41.75	46.00	4.25
288.0200	47.28	QP	-6.33	40.95	46.00	5.05
480.0800	44.55	QP	-2.28	42.27	46.00	3.73
700.2700	44.12	QP	0.38	44.50	46.00	1.50
768.1700	41.32	QP	1.38	42.70	46.00	3.30

**Mode: USB Input & HDMI Output**

**Horizontal:**

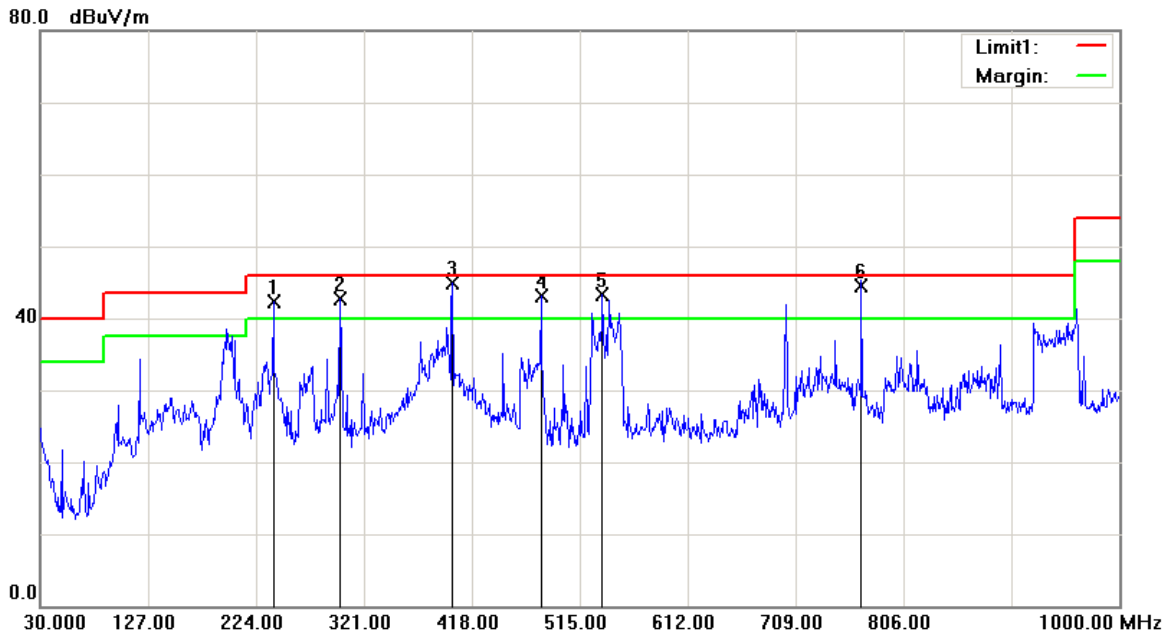

Frequency (MHz)	Receiver Reading (dBuV/m)	Detector (PK/QP/Av e)	Correction Factor (dB)	Cord. Amp. (dBuV/m)	Limit (dBuV/m)	Margin (dB)
239.5200	50.45	QP	-8.11	42.34	46.00	3.66
299.6600	48.85	QP	-6.20	42.65	46.00	3.35
400.5400	48.96	QP	-4.09	44.87	46.00	1.13
480.0800	45.33	QP	-2.28	43.05	46.00	2.95
535.3700	45.30	QP	-1.93	43.37	46.00	2.63
768.1700	43.22	QP	1.38	44.60	46.00	1.40



**Vertical:**

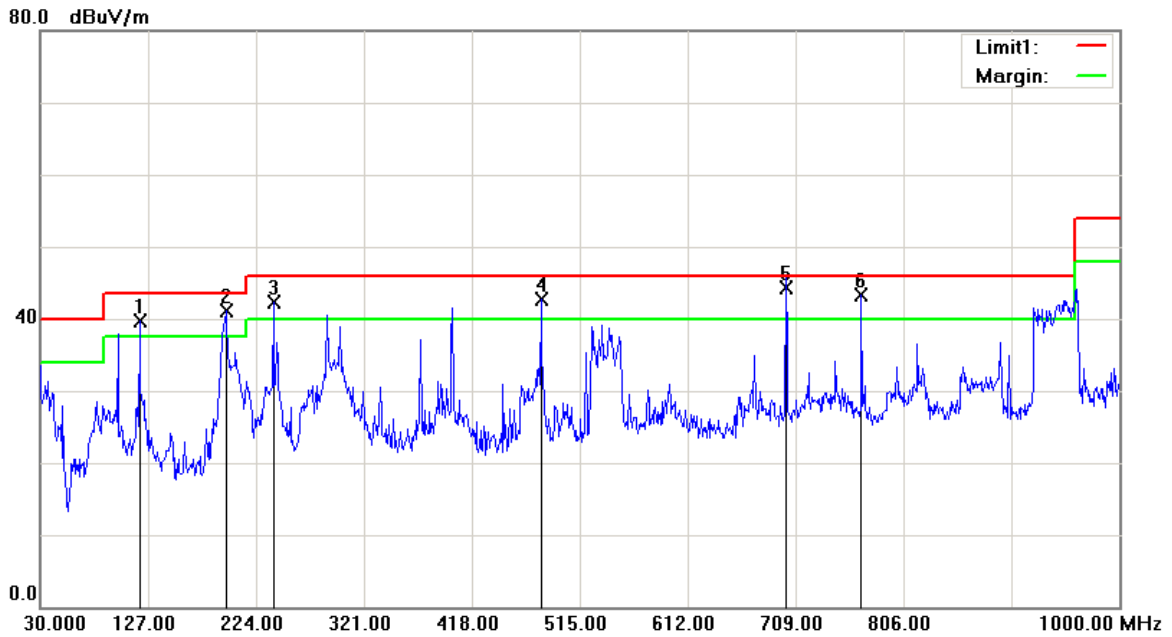

Frequency (MHz)	Receiver Reading (dBuV/m)	Detector (PK/QP/Av e)	Correction Factor (dB)	Cord. Amp. (dBuV/m)	Limit (dBuV/m)	Margin (dB)
119.2400	46.25	QP	-6.50	39.75	43.50	3.75
196.8400	49.24	QP	-8.20	41.04	43.50	2.46
239.5200	50.33	QP	-8.11	42.22	46.00	3.78
480.0800	45.08	QP	-2.28	42.80	46.00	3.20
700.2700	43.92	QP	0.38	44.30	46.00	1.70
768.1700	42.00	QP	1.38	43.38	46.00	2.62

**Above 1GHz**

**Mode: SD Card Input & HDMI Output**

**Horizontal:**

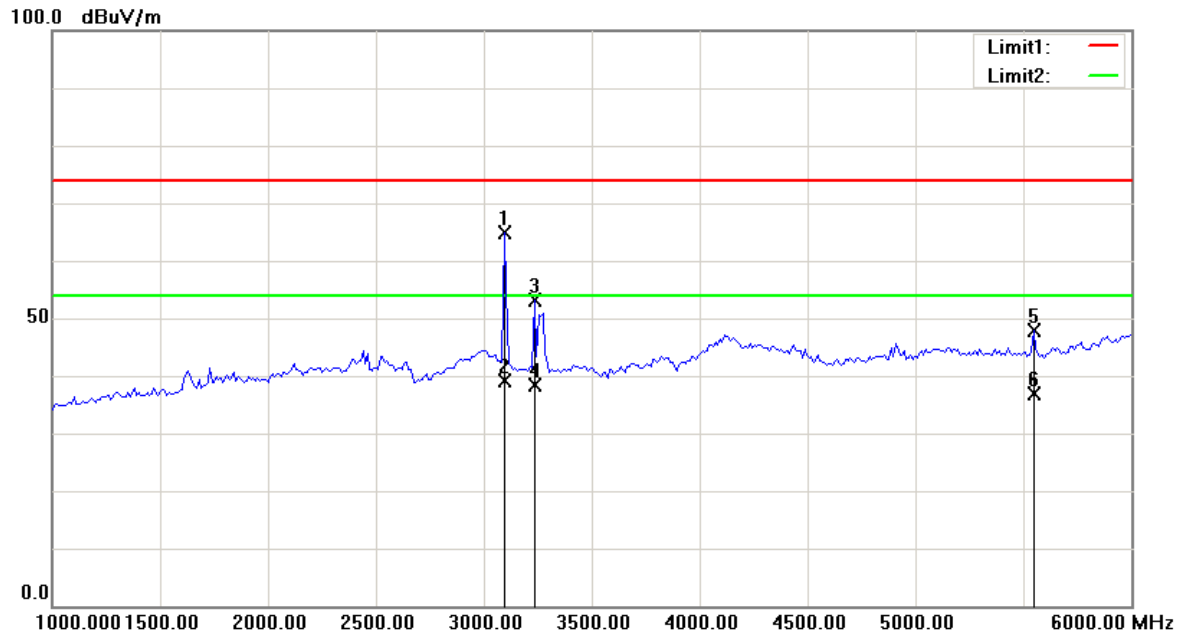

Frequency (MHz)	Receiver Reading (dBuV/m)	Detector (PK/QP/Average)	Correction Factor (dB)	Cord. Amp. (dBuV/m)	Limit (dBuV/m)	Margin (dB)
3094.188	55.87	peak	8.95	64.82	74.00	9.18
3094.188	30.18	AVG	8.95	39.13	54.00	14.87
3234.469	44.07	peak	9.02	53.09	74.00	20.91
3234.469	29.47	AVG	9.02	38.49	54.00	15.51
5549.098	35.47	peak	12.34	47.81	74.00	26.19
5549.098	24.55	AVG	12.34	36.89	54.00	17.11

**Vertical:**

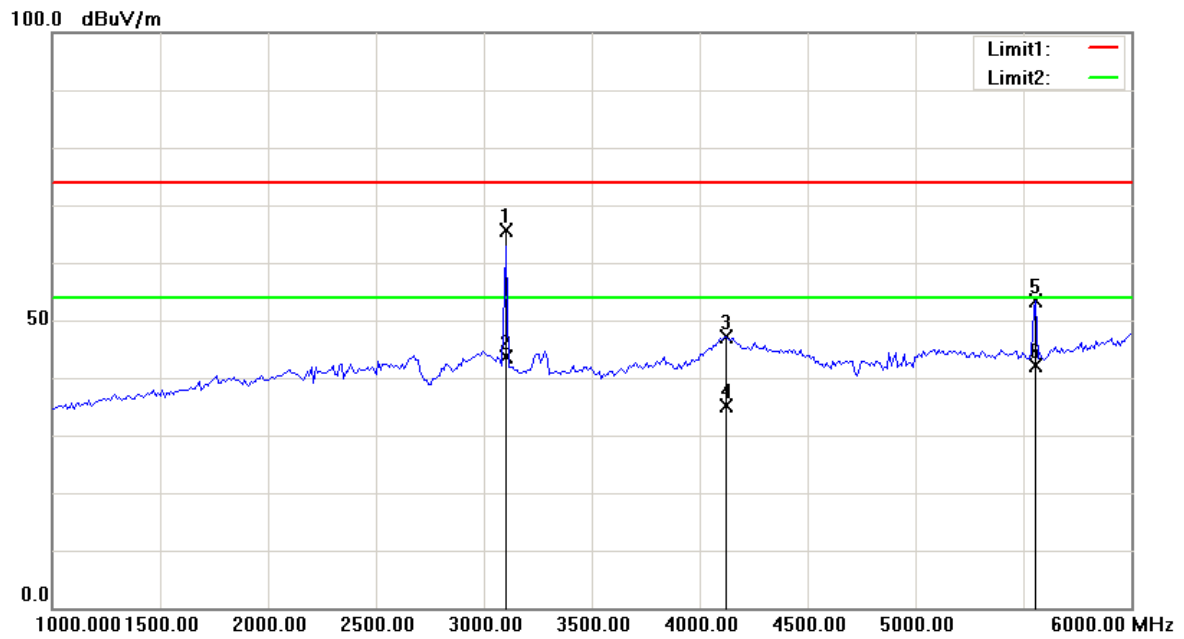

Frequency (MHz)	Receiver Reading (dBuV/m)	Detector (PK/QP/Average)	Correction Factor (dB)	Cord. Amp. (dBuV/m)	Limit (dBuV/m)	Margin (dB)
3104.208	56.77	peak	8.81	65.58	74.00	8.42
3104.208	34.88	AVG	8.81	43.69	54.00	10.31
4126.252	33.85	peak	13.33	47.18	74.00	26.82
4126.252	21.79	AVG	13.33	35.12	54.00	18.88
5559.118	41.10	peak	12.23	53.33	74.00	20.67
5559.118	29.80	AVG	12.23	42.03	54.00	11.97

**Mode: USB Input & HDMI Output**

**Horizontal:**

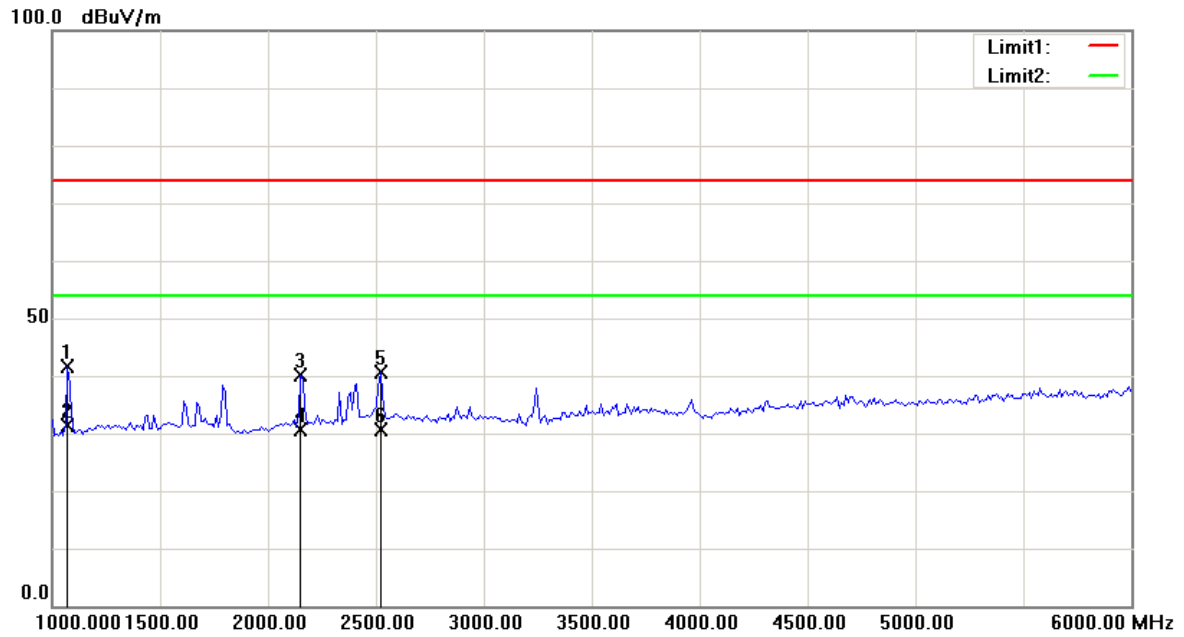

Frequency (MHz)	Receiver Reading (dBuV/m)	Detector (PK/QP/Ave)	Correction Factor (dB)	Cord. Amp. (dBuV/m)	Limit (dBuV/m)	Margin (dB)
1070.140	46.46	peak	-4.71	41.75	74.00	32.25
1070.140	36.09	AVG	-4.71	31.38	54.00	22.62
2152.305	42.26	peak	-2.23	40.03	74.00	33.97
2152.305	32.75	AVG	-2.23	30.52	54.00	23.48
2523.046	41.85	peak	-1.32	40.53	74.00	33.47
2523.046	32.04	AVG	-1.32	30.72	54.00	23.28

**Vertical:**

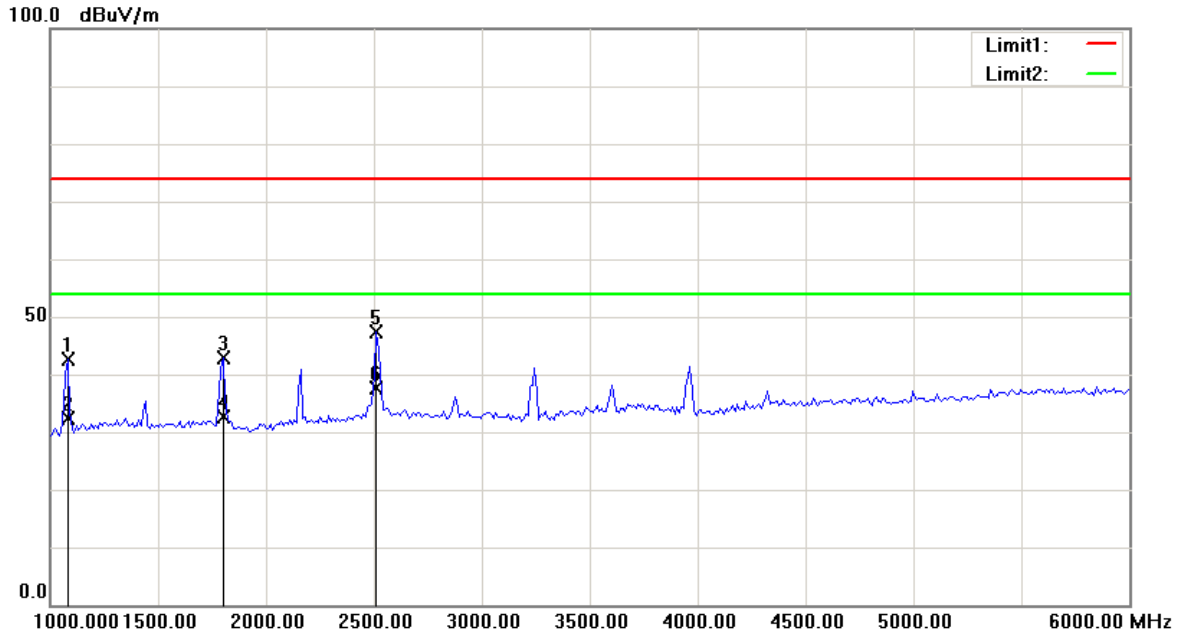

Frequency (MHz)	Receiver Reading (dBuV/m)	Detector (PK/QP/Average)	Correction Factor (dB)	Cord. Amp. (dBuV/m)	Limit (dBuV/m)	Margin (dB)
1080.160	47.26	peak	-4.68	42.58	74.00	31.42
1080.160	37.04	AVG	-4.68	32.36	54.00	21.64
1801.603	45.62	peak	-2.82	42.80	74.00	31.20
1801.603	35.54	AVG	-2.82	32.72	54.00	21.28
2513.026	48.60	peak	-1.34	47.26	74.00	26.74
2513.026	38.98	AVG	-1.34	37.64	54.00	16.36

\*\*\*\*\* END OF REPORT \*\*\*\*\*