

**DuraLabel Pro 200 /  
DuraLabel Pro 300**

**THERMAL TRANSFER / DIRECT THERMAL  
BAR CODE PRINTER**

**USER'S  
MANUAL**

# Contents

1. Introduction .....	1
2. Getting Started .....	1
2.1 Unpacking and Inspection.....	1
2.2 Equipment Checklist.....	1
2.3 Printer Parts.....	3
3. Setup.....	4
3.1 Setting Up the Printer .....	4
3.2 Loading the Ribbon.....	4
3.3 Loading Label Stock .....	6
3.4 External Label Roll Mount Installation (Option) .....	8
3.5 Peel-off Module Installation (Option).....	9
3.5.1 Loading the Paper in Peel-off Mode.....	12
3.6 Cutter Module Installation (Option) .....	14
3.6.1 Loading Label in Cutter Mode .....	17
3.7 Instructions to Top Cover Operation.....	18
4. Power on Utilities.....	21
4.1 Ribbon and Gap/Black Mark Sensor Calibration.....	21
4.2 Gap/Black Mark Calibration ; Self-test ; Dump Mode.....	22
4.3 Printer Initialization .....	25
4.4 Black Mark Sensor Calibration .....	26
4.5 Gap Sensor Calibration .....	26
4.6 Skip AUTO.BAS.....	26
5. Maintenance .....	28
5.1 Cleaning .....	28
6. Troubleshooting.....	29
6.1 LED Status .....	29
6.2 Print Quality.....	30
7. Specifications .....	31
7.1 Printer Specifications .....	31
7.2 Label Stock Specifications.....	31
7.3 Ribbon Specifications.....	31
8. LED and Button Operation.....	33
8.1 LED.....	33
8.2 Button Operation.....	33
Update History .....	36

# Compliances

CE Class B:

EN55022: 1998+A1: 2000+A2: 2003

EN55024: 1998+A1: 2001+A2: 2003 IEC 61000-4 Series

EN61000-3-2: 2006 & EN61000-3-3: 1995+A1: 2001

FCC Part 15, Class B

This device complies with Part 15 of the FCC Rules.

Operation is subject to the following two conditions:

(1) this device may not cause harmful interference and

(2) this device must accept any interference received, including interference that may cause undesired operation.

UL, CUL

C-Tick:

CFR 47, Part 15/CISPR 22 3<sup>rd</sup> Edition: 1997, Class B

ANSI C63.4: 2003

Canadian ICES-003

TÜV-GS: EN60950: 2000

# 1. Introduction

Thank you for purchasing the Thermal Transfer and Direct Thermal Bar Code Printers. Although the printer takes only a small amount of space, it delivers reliable, superior performance.

## 2. Getting Started

### 2.1 Unpacking and Inspection

This printer has been specially packaged to withstand damage during shipping. Please carefully inspect the packaging and printer upon receiving the bar code printer. Please retain the packaging materials in case you need to reship the printer.

### 2.2 Equipment Checklist

- One printer unit
- One Windows labeling software/driver CD disk
- One sample ribbon roll
- One sample label roll
- One label spindle (1 inch diameter core)
- Two label spindle fixed tabs
- Two 1.5" core adapter
- One paper core for ribbon rewind spindle
- Two ribbon supply/rewind spindles
- One Centronics interface cable
- One auto switching power supply
- One power cord
- One quick start guide

If any parts are missing, please contact the Customer Service Department of your purchased reseller or distributor.

#### Options

- External label roll mount

- Label spindle (3-inch diameter core)
- Programmable keyboard
- Stand-alone LCD keyboard
- Automatic cutter module
- Peel off module
- Internal Ethernet print server
- External 802.11b/g wireless print server

### 2.3 Printer Parts

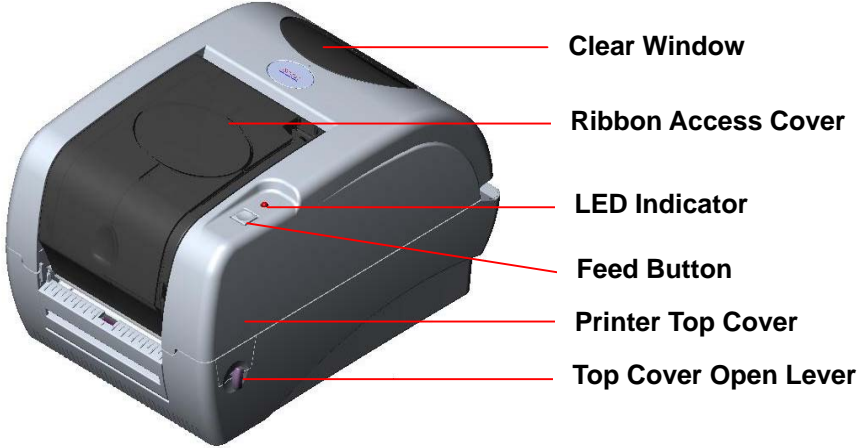

Fig. 1 Top front view

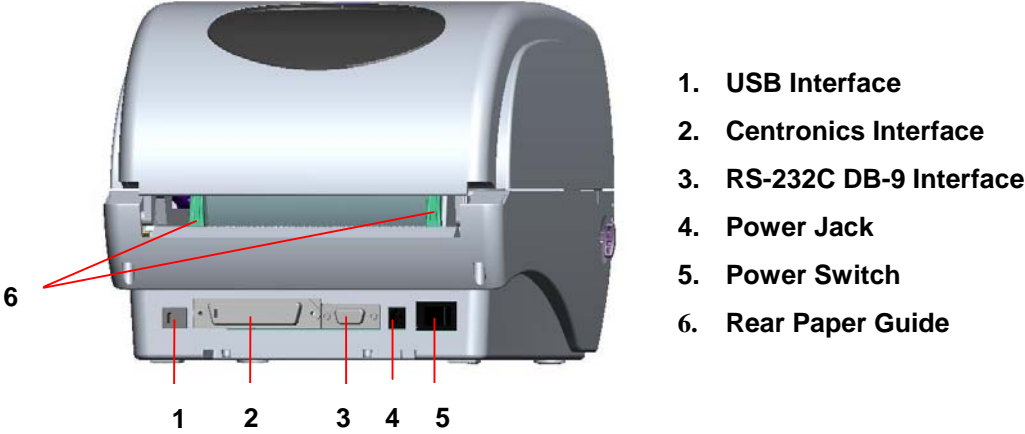
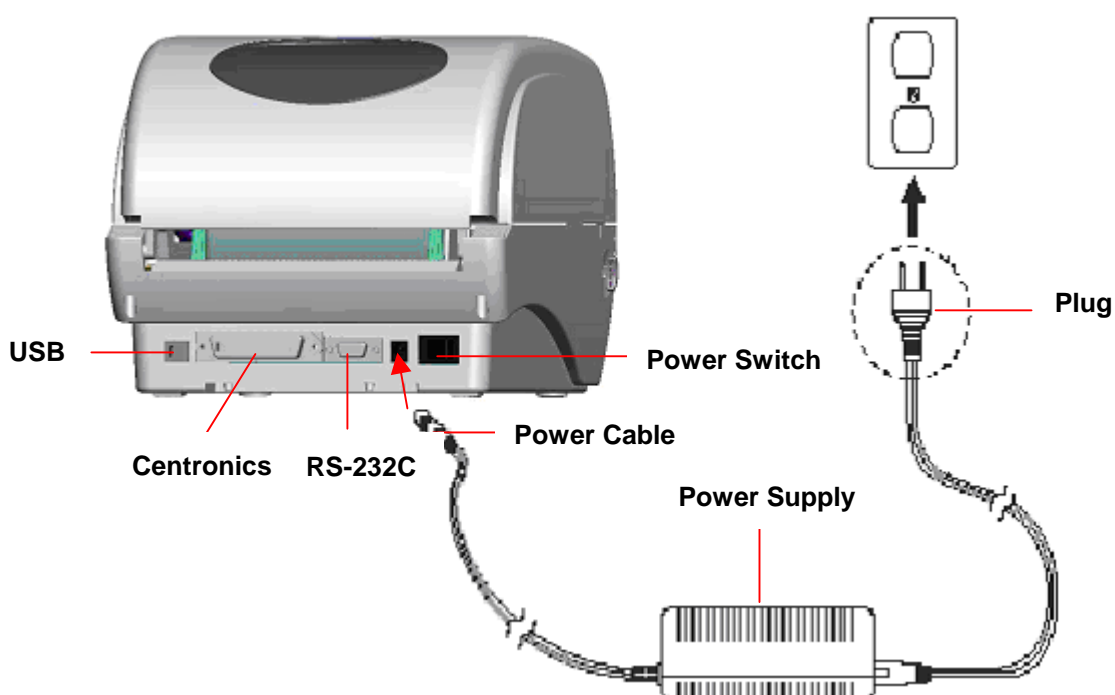

Fig. 2 Rear view

## 3. Setup

### 3.1 Setting Up the Printer

1. Place the printer on a flat, secure surface.
2. Make sure the power switch is off.
3. Connect the printer to the computer with the Centronics or USB cable.
4. Plug the power cord into the power supply connector at the rear of the printer, and then plug the power cord into a properly grounded receptacle.



**Fig. 3 Attach power supply to printer**

### 3.2 Loading the Ribbon

The printer will detect if the ribbon is installed after turning on power on and it will set printing mode to thermal transfer or direct thermal printing mode. If printer does not detect the ribbon, the ribbon take up motor will be turned off.

Make sure both the ribbon access window and the printer top cover are closed prior to

powering up the printer.

Please follow the steps below to install the ribbon into printer.

1. Push down on the ribbon access window to unlatch and open the cover.
2. Place a paper core onto the ribbon rewind spindle.
3. Mount the ribbon rewind paper core on the front hubs.
4. Install a ribbon on the ribbon supply spindle.
5. Mount the ribbon supply spindle on the rear hubs.
6. Thread the ribbon leading tape downward pass the print head.
7. Attach the ribbon leader to the ribbon rewind paper core.
8. Rotate the ribbon rewind paper core until the ribbon leader is thoroughly, firmly encompassed by the black section of the ribbon.
9. Close the ribbon access window.

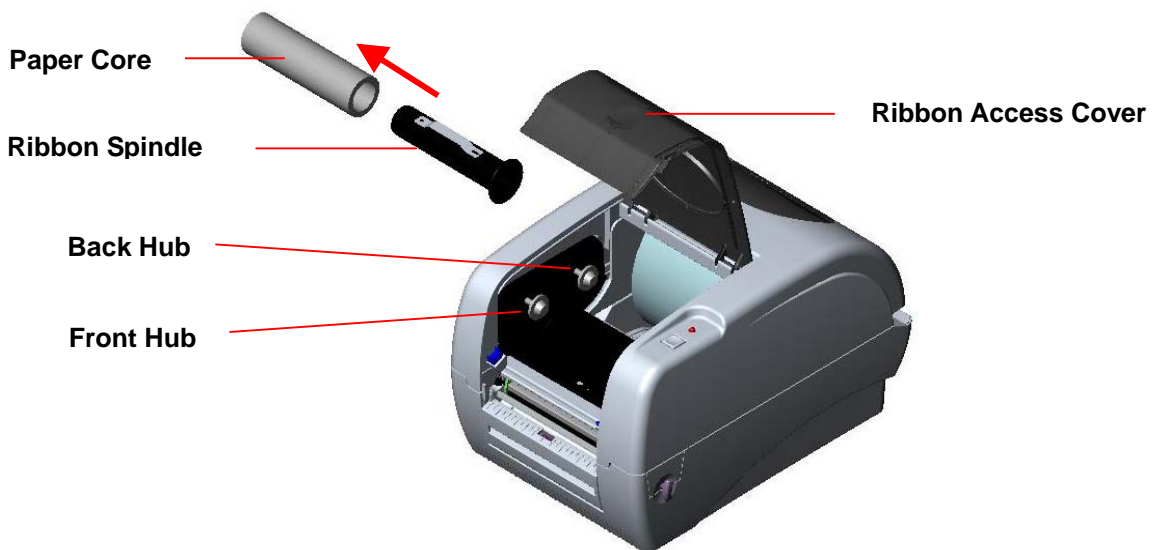

**Fig. 4 Ribbon installation (I)**

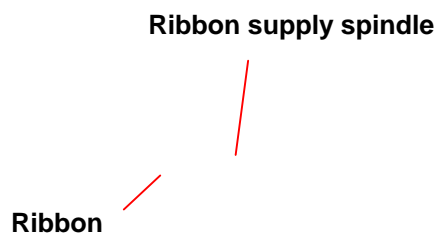

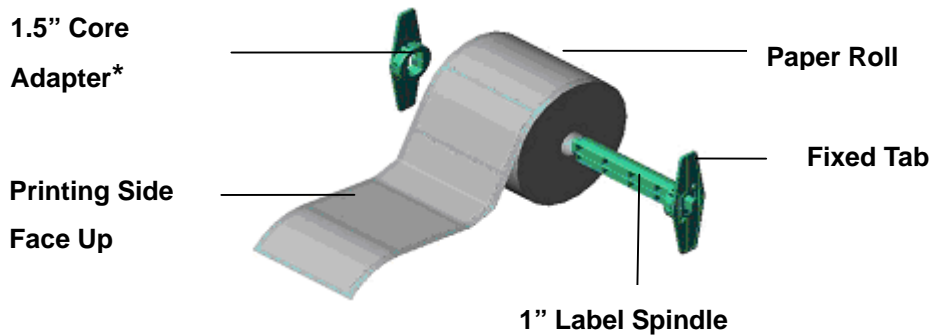



**Fig. 5 Ribbon installation (II)**

### 3.3 Loading Label Stock

1. Insert a 1" label spindle into a paper roll ( \* If your paper core is 1 inch, remove the 1.5" core adapter from the fixed tab. If label width is 4 inch wide, two fixing tabs are not required. ).



**Fig. 6 Label roll installation (I)**

2. Open the printer's top cover by releasing the green top cover open levers located on each side of the printer and lifting the top cover. A top cover support at the rear of the printer will hold the printer top cover open.

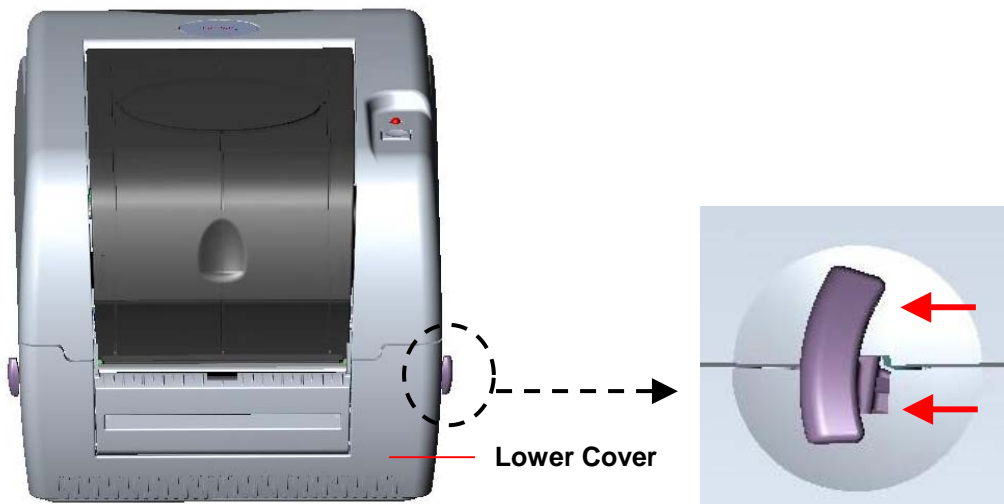
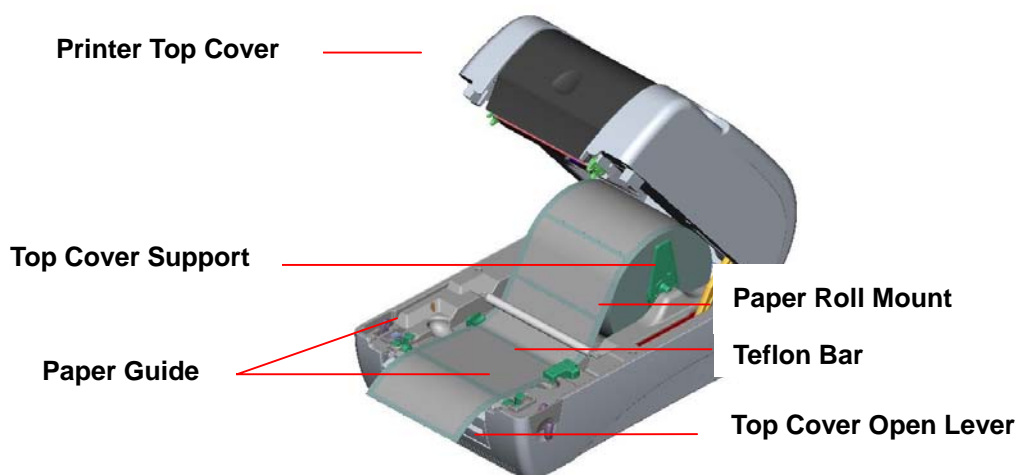

**Fig. 7 Pull the lever to open the cover**

3. Place a roll of paper onto the center of the paper roll mount.
4. Feed the paper, printing side face up, through the Teflon bar and the paper guide and pass over the platen.
5. Adjust the green center-biased paper guides to slightly touch the edges of the label backing.
6. To close the printer top cover, lift the cover to the ultimate open angle then use both hands to close the cover gently. Close the printer top cover slowly and make sure the cover latches securely.

**Note:**

1. ***Make sure hands are not placed between printer top cover and lower cover when close the top cover.***
2. ***Do not free fall the top cover.***
3. ***Failure to securely close and lock the cover will result in poor print quality.***



**Fig. 8 Label installation (II)**

### **3.4 External Label Roll Mount Installation (Option)**

1. Attach an external paper roll mount on the bottom of the printer.

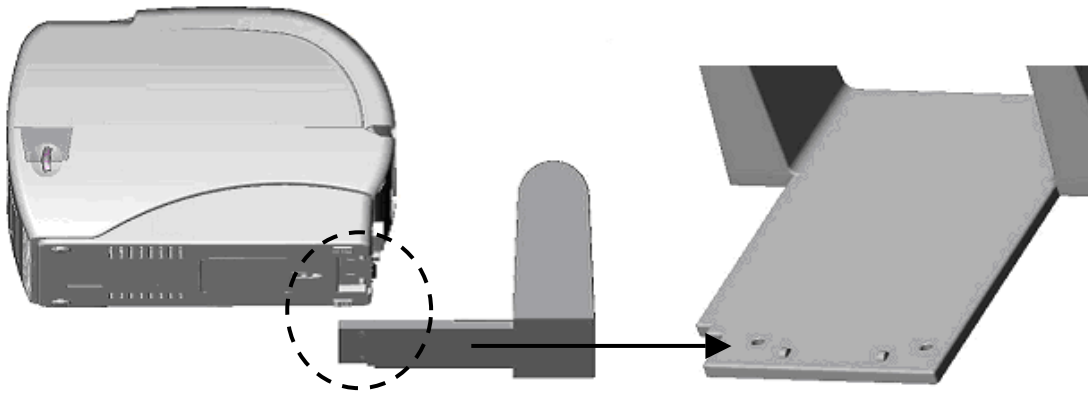

**Fig. 9 Attach the external roll mount to the printer**

1. Open the printer top cover by releasing the top cover open levers. The top cover support will hold the printer top cover.
2. Install a roll of paper on the external paper roll mount.
3. Feed the paper to the external paper feed opening through the rear paper guide.

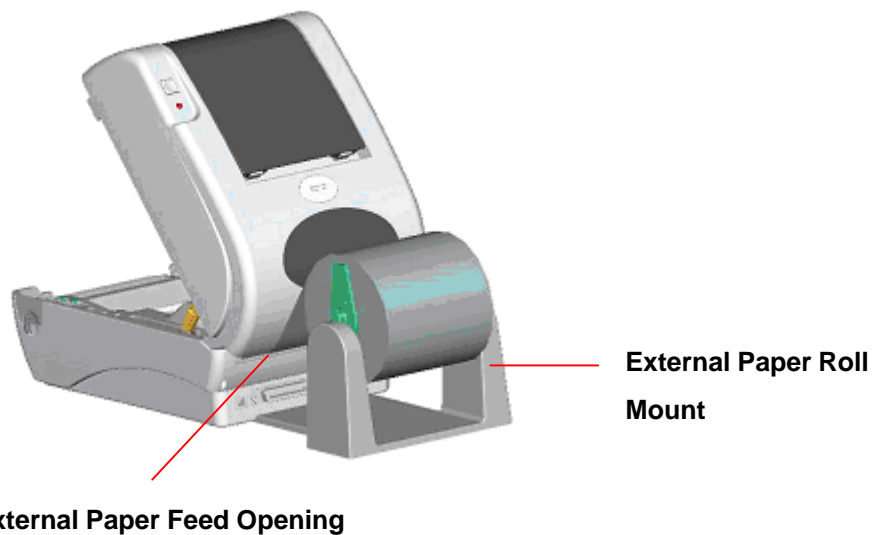

**Fig. 10 External roll mount label installation (I)**

4. Feed the paper, printing side face up, through the paper guide and pass over the platen.

- Adjust the paper guides to fit the paper width.
- Close the printer top cover by lifting the top cover to the maximum opening angle then push down the top cover gently.

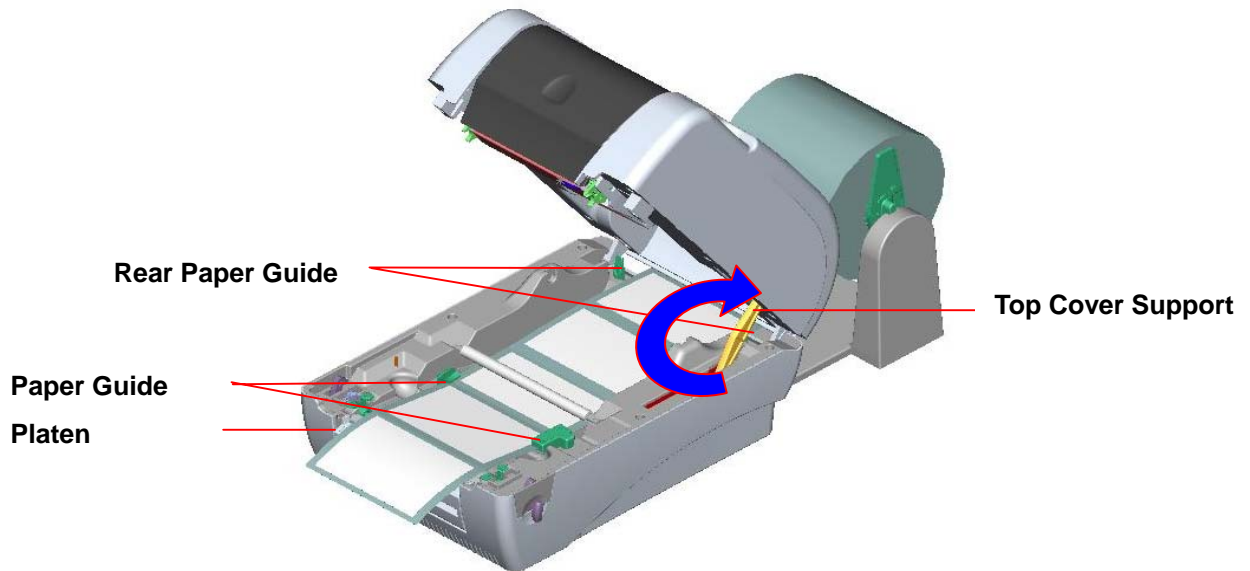

**Fig. 11 External roll mount label installation (II)**

### 3.5 Peel-off Module Installation (Option)

- Open the top cover and remove the front panel from the printer.

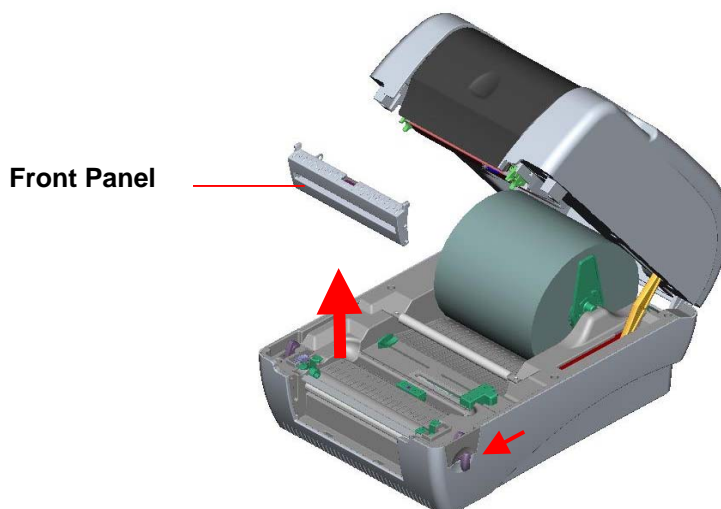

**Fig. 12 Remove the front panel**

- Open the top cover and hold it and push down and push backward the top cover support then push backward the top cover.

3. Use a screwdriver to screw off 6 screws on the lower inner cover.

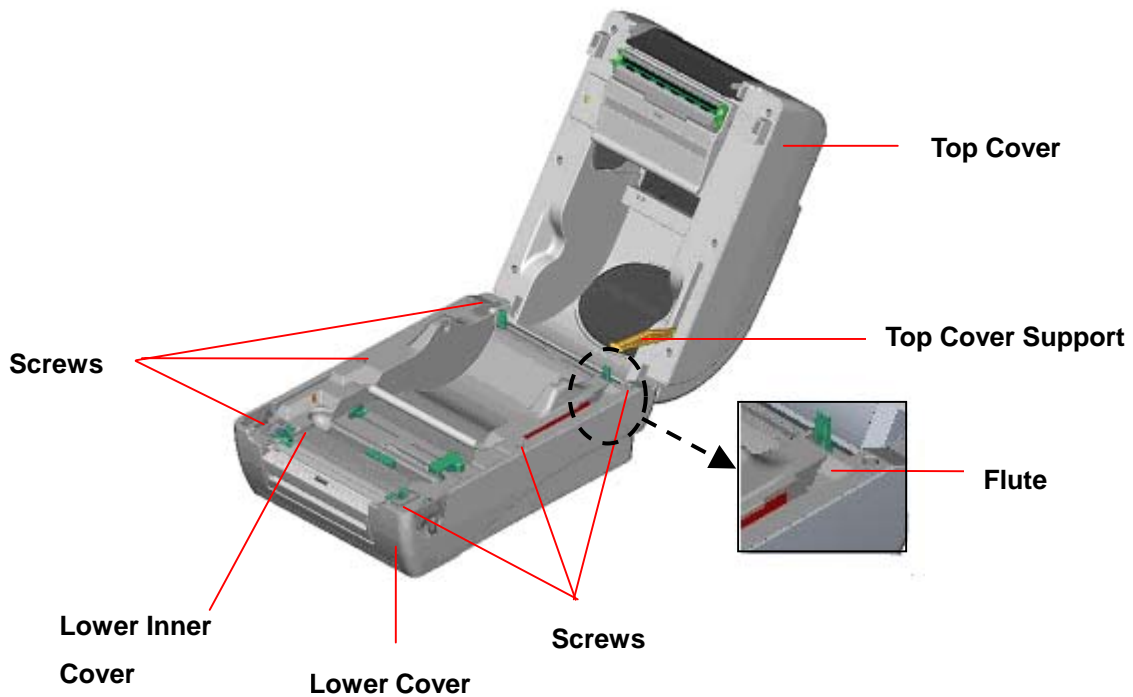

**Fig. 13 Remove 6 screws from lower inner cover**

4. Upside down the printer. Remove two screws at the hinge and remove one screw at memory card cover.
5. Hold the lower cover to lift up the top cover open levers to separate the lower inner cover and the lower cover.
6. Arrange the cable through the bezel. Connect the peel-off panel cable to the 5-pin socket on printer PCB.

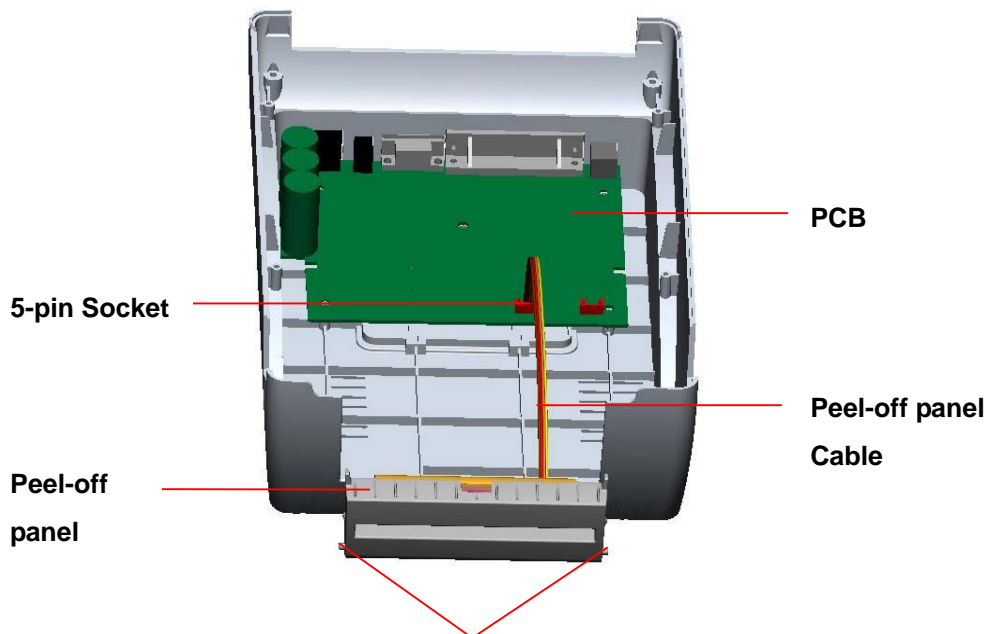

Tenon

**Fig. 14 Connect peel-off sensor cable to main board**

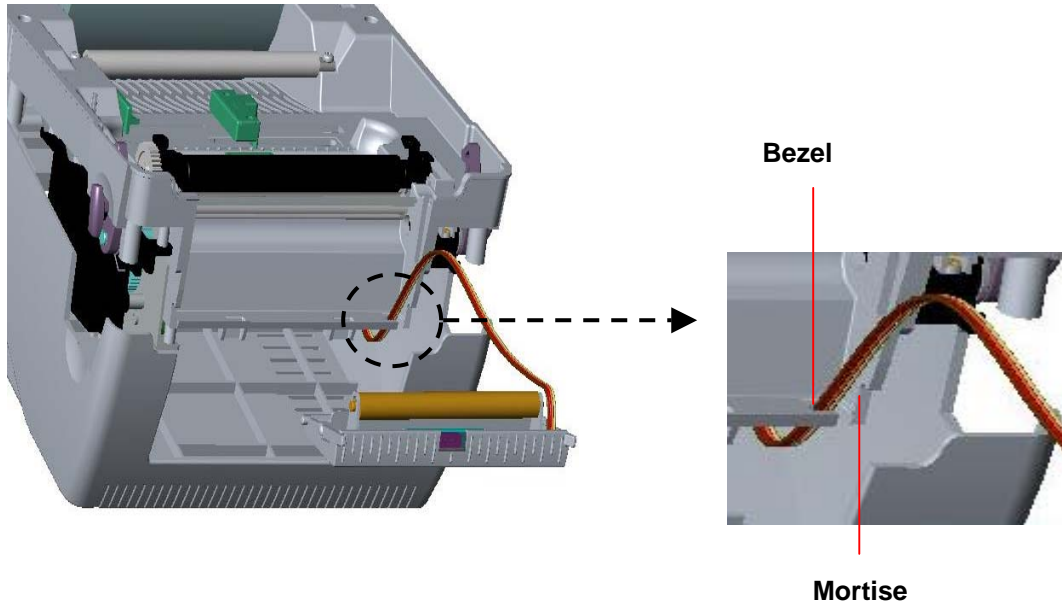

**Fig. 15 Peel-off sensor cable installation**

7. Flat a peel-off panel and embed the tenons in mortises, and you will hear a kick sound.

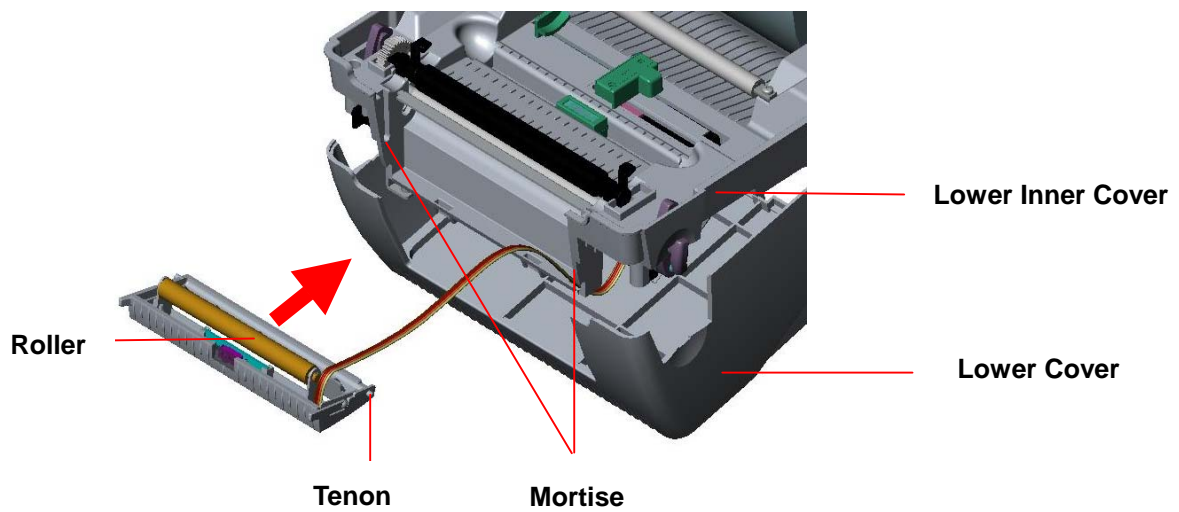

**Fig. 16 Peel-off panel installation (I)**

8. Arrange the lower inner cover back to the lower cover.

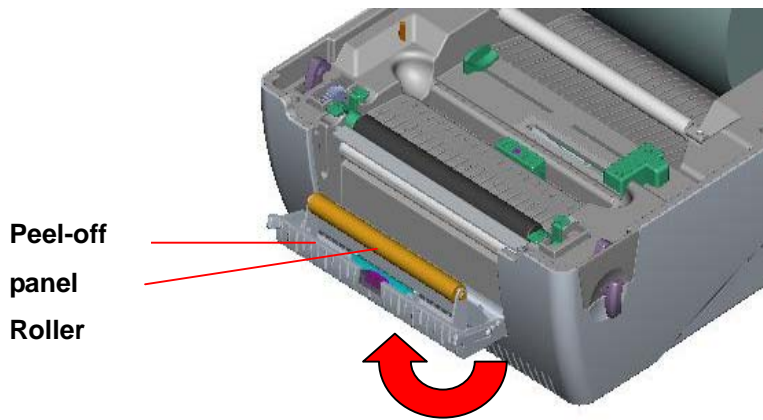

**Fig. 17 Peel-off panel installation (II)**

9. Lift up the peel-off panel to the lower cover to close it.
10. Use a screwdriver to screw down whole screws on the lower inner cover and the lower cover.
11. Close the top cover by arranging the top cover support back to the flute and push it forward then close the top cover slowly.

### 3.5.1 Loading the Paper in Peel-off Mode

***Note: Both thermal paper and plain paper apply for peel-off function but neither PVC nor vynle work at peel-off function.***

1. Insert a 1" label spindle into a paper roll.
2. Open the printer top cover by pulling the top cover open levers. The top cover support will hold the printer top cover.



**Fig. 18 Open the top cover**

3. Install the paper roll on the paper roll mount.
4. Open the peel-off panel by pulling it out.

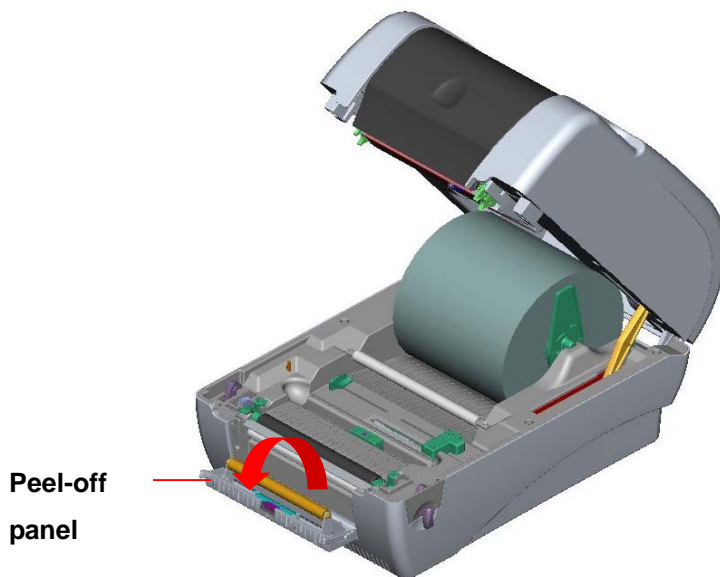

**Fig. 19 Open the peel-off panel**

5. Feed the paper, printing side facing up, through the paper guide and pass over the platen.
6. Lead the paper through the backing paper opening, beneath the roller, pull the
7. Adjust the paper guide by removing left or right to fit the paper width.



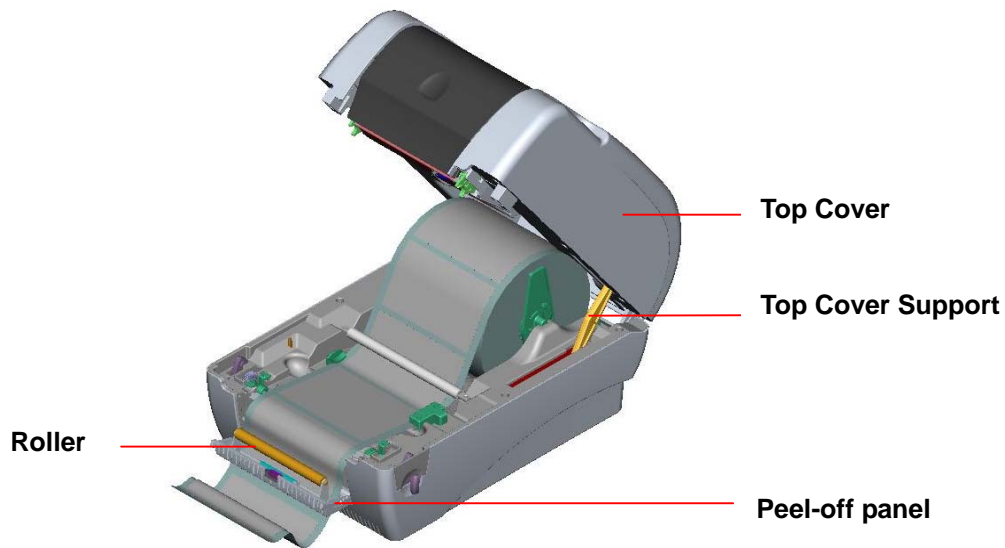

**Fig. 20 Lead the paper through the backing paper opening, beneath the roller**

8. Push the peel-off panel back to the printer.
9. Close the top cover by lifting up the top cover support and close the top cover slowly.

**Note: Pull the label outward tightly after closing the top cover.**



**Fig. 21 Complete label installation for peel-off mode**

### **3.6 Cutter Module Installation (Option)**

1. Pull the top cover open levers to open the top cover.
2. Remove the front panel from the lower cover.

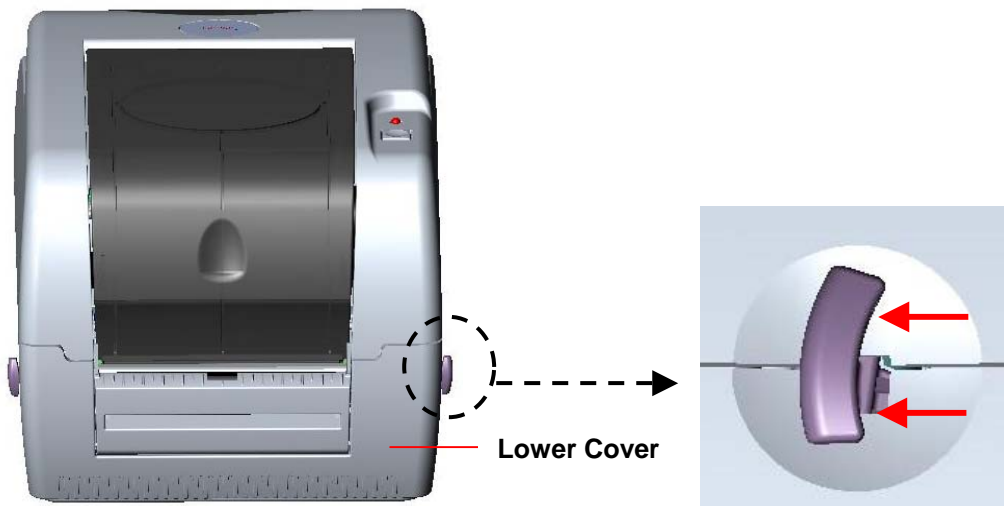

**Fig. 22 Pull the lever to open the cover**

3. Open the top cover and hold it and push down and push backward the top cover support then push backward the top cover.
4. Use a screwdriver to screw off 6 **screws** on the **lower inner cover**.

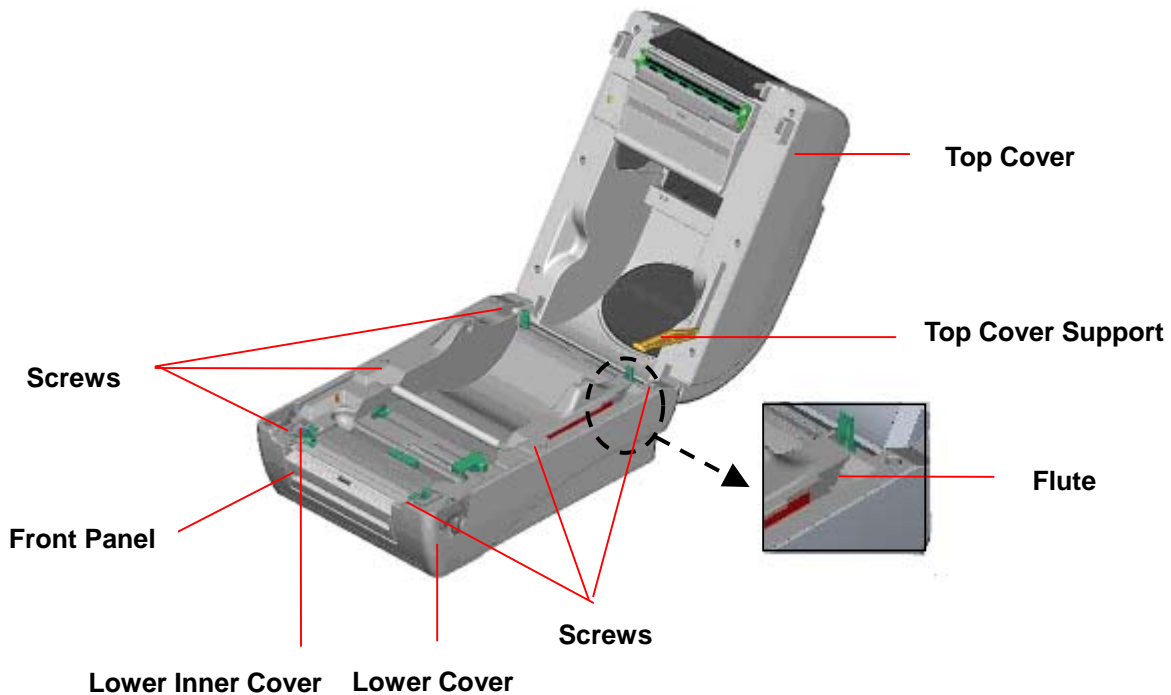
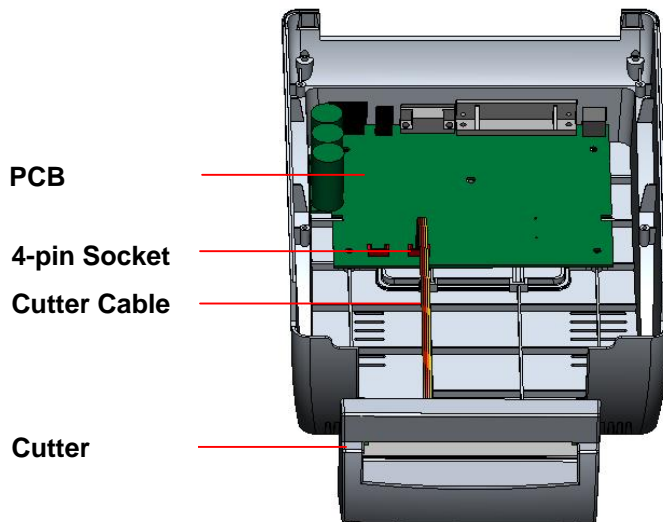

**Fig. 23 Remove 6 screws from lower inner cover**

5. Place the printer upside down and unscrew the two screws of the **hinge holder** on the lower cover. Unscrew the screw of the **memory card cover**.
6. Use both thumbs to hold the lower cover and index fingers to lift up the top cover

open levers to separate the lower inner cover and the lower cover.

7. Arrange the cable through the bezel. Connect the cutter module cable to the 4-pin socket on printer PCB.



**Fig. 24 Cutter module installation**

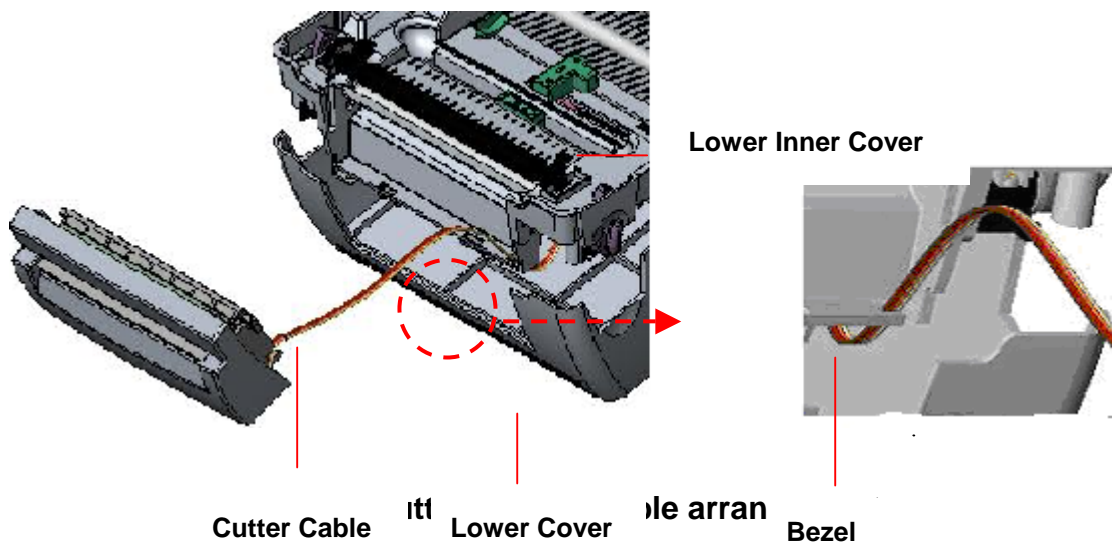

8. Arrange the lower inner cover back to the lower cover.
9. Install the cutter into the niches of the printer.

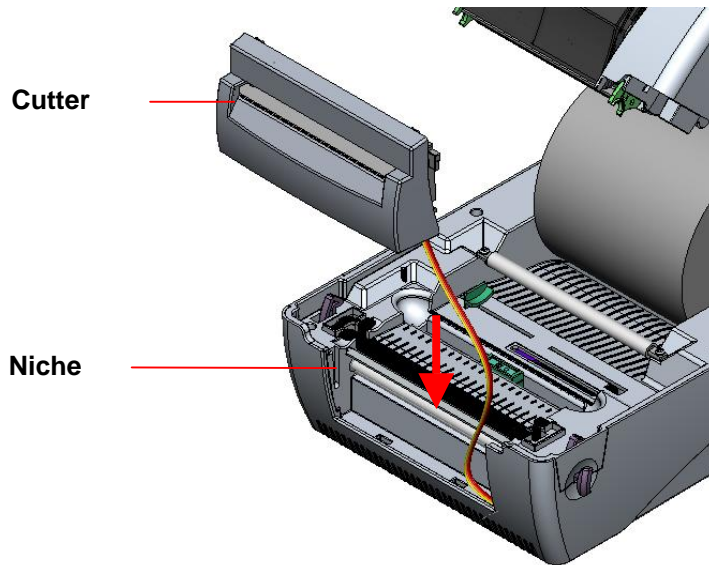
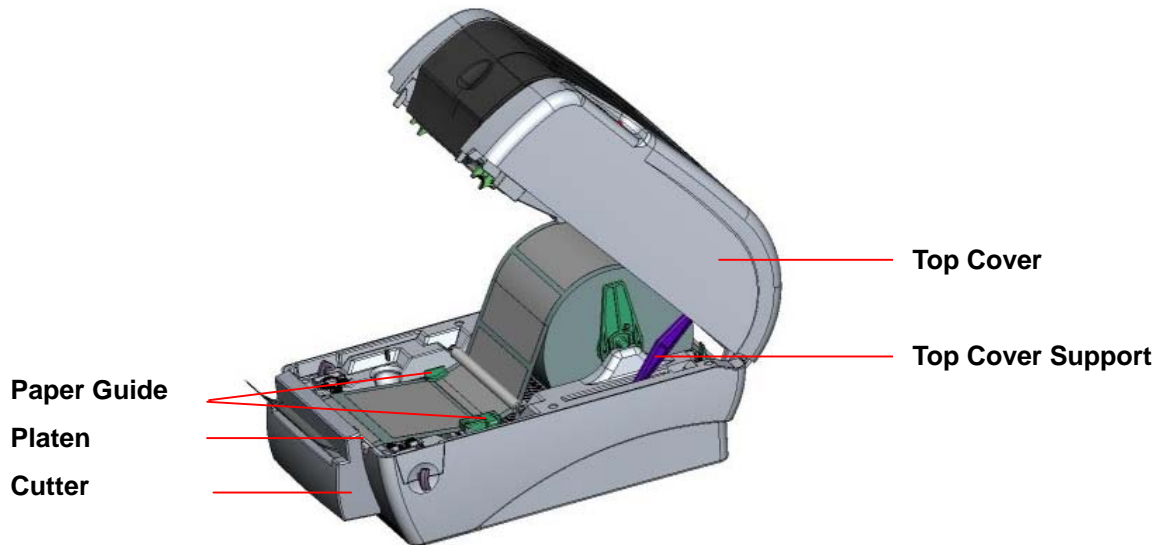

**Fig. 26 Cutter module installation**

10. Use a screwdriver to screw whole screws on the lower inner cover and the lower cover.
11. Close the top cover by arranging the top cover support back to the flute and push it forward then close the top cover slowly.

### **3.6.1 Loading Label in Cutter Mode**

1. Insert a 1" label spindle into a paper roll.
2. Open the printer top.
3. Install a paper roll on the paper roll mount.
4. Feed the paper, printing side face up, through the paper guide and pass over the platen.
5. Lead the paper through the cutter paper opening.
6. Adjust the paper guide by removing left or right to fit the paper width.



**Fig. 27 Label installation in cutter mode**

7. Close the top cover by lifting up the top cover support and close the top cover slowly.



**Fig. 28 Complete label installation in cutter mode**

### **3.7 Instructions to Top Cover Operation**

Please take care when opening or closing the printer's top cover by carefully following these instructions.

To Open:

1. When facing the front of the printer pull the cover release levers on both sides of printer towards you.
2. Lift up the top gradually.

There are two stop positions for the top cover. Position 1 and 2 are indicated on the label below.

**Note: To hold the cover open at position 1, you must lift the cover higher than the stopping point at position 1 and gently lower the cover to stopping point 1. Do not let the cover free fall!**

3. Fully open the top cover and gently lower it to stop position 2.



Fig. 1 Top cover support is fixed at position 2

4. To close the cover, lift up the top cover to the ultimate angle then close the top cover gently and it will be kept at a stop position between 1 and 2 for a while. Use both hands to gently push down the top cover to close it and make sure the cover is latched on both sides.

**Note: Do not place your hands between top cover and lower cover when closing the top cover!**



Fig. 2 Top cover is fully open and ready to close



Fig. 3 Use both hands to close the top cover

5. ***Do not force the cover!*** If you are not sure if top cover is fixed at stop position, please do not push top cover to close it or the top cover will be damaged. Please open the top cover to the ultimate angle to close the top cover again. Use both hands to push top cover to close it.

## 4. Power on Utilities

There are six power-on utilities to set up and test printer hardware. These utilities are activated by pressing FEED button and by turning on the printer power simultaneously.

The utilities are listed as below:

1. Ribbon sensor calibration ; Gap/black mark sensor calibration
2. Gap/black mark sensor calibration ; Self-test and dump mode
3. Printer initialization
4. Black mark sensor calibration
5. Gap sensor calibration
6. Skip AUTO.BAS

### 4.1 Ribbon and Gap/Black Mark Sensor Calibration

Gap/black mark sensor sensitivity should be calibrated at the following conditions:

1. A brand new printer
2. Change label stock.
3. Printer initialization.

Please follow the steps below to calibrate the ribbon and gap/black mark sensor.

1. Turn off the power switch.
2. Hold on the button then turn on the power switch.
- 3 Release the button when LED becomes **red** and blinking. (Any red will do during the 5 blinks).
  - It will calibrate the ribbon sensor and gap/black mark sensor sensitivity.
  - The LED color will be changed as following order :  
Amber → **red (5 blinks)** → amber (5 blinks) → green (5 blinks) → green/amber (5 blinks) → red/amber (5 blinks) → solid green

#### Note:

**Please select gap or black mark sensor by GAP or BLINE command prior to calibrate the sensor.**

**For more information about GAP and BLINE command, please refer to TSPL2 programming manual.**



## 4.2 Gap/Black Mark Calibration ; Self-test ; Dump Mode

While calibrate the gap/black mark sensor, printer will measure the label length, print the internal configuration (self-test) and then enter the dump mode. To calibrate gap or black mark sensor, depends on the sensor setting in the last print job.

Please follow the steps below to calibrate the sensor.

1. Turn off the power switch.
2. Hold on the button then turn on the power switch.
3. Release the button when LED becomes **amber** and blinking. (Any amber will do during the 5 blinks).
  - The LED color will be changed as following order.  
Amber → red (5 blinks) → **amber (5 blinks)** → green (5 blinks) → green/amber (5 blinks) → red/amber (5 blinks) → solid green
4. It calibrates the sensor and measures the label length and prints internal settings then enter the dump mode.

### Note:

**Please select gap or black mark sensor by GAP or BLINE command prior to calibrate the sensor.**

**For more information about GAP and BLINE command, please refer to TSPL2 programming manual.**

## Self-test

Printer will print the printer configuration after gap/black mark sensor calibration. Self-test printout can be used to check if there is any dot damage on the heater element, printer configurations and available memory space.

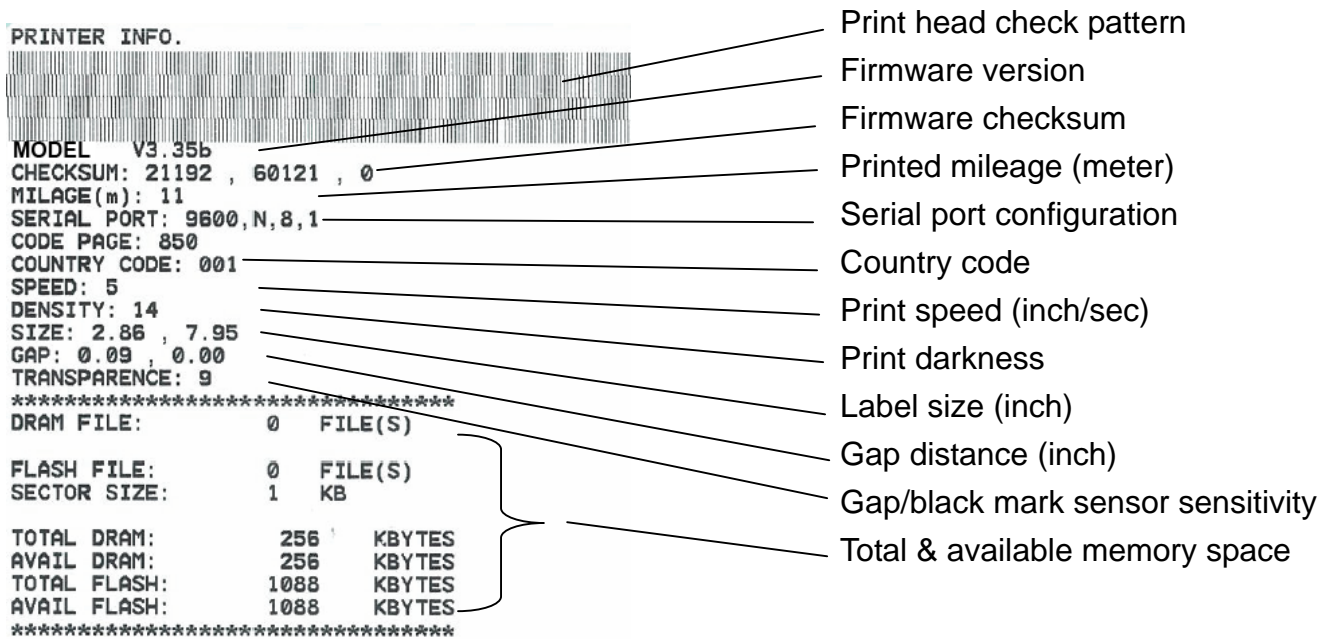

Fig. 29 Self-test printout

### Note:

1. The physical flash memory for RoHS compliant version is 2MB Flash and 2MB DRAM.
2. System occupies 960 KB in Flash memory so total flash memory space for user downloading is 1088 KB
3. System occupies 1792 KB in DRAM so total DRAM memory space for user downloading is 256 KB

## Dump mode

Printer will enter dump mode after printing printer configuration. In the dump mode, all characters will be printed in 2 columns as following. The left side characters are received from your system and right side data are the corresponding hexadecimal value of the characters. It allows users or engineers to verify and debug the program.

<p>ASCII Data →</p>	<pre> SPEED 2.0 53 50 45 45 44 20 32 2E 30 0D DENSITY 8 0A 44 45 4E 53 49 54 59 20 38 SET PEEL 0D 0A 53 45 54 20 50 45 45 4C OFF DIRE 20 4F 46 46 0D 0A 44 49 52 45 CTION 0 G 43 54 49 4F 4E 20 30 0D 0A 47 AP 3.00 mm 41 50 20 33 2E 30 30 20 6D 6D .0.00 mm 2C 30 2E 30 30 20 6D 6D 0D 0A REFERENCE 52 45 46 45 52 45 4E 43 45 20 0.0 SET C 30 2C 30 0D 0A 53 45 54 20 43 UTTER OFF 55 54 54 45 52 20 4F 46 46 0D SIZE 100. 0A 53 49 5A 45 20 31 30 30 2E 02 mm,65.0 30 32 20 6D 6D 2C 36 35 2E 30 4 mm CLS 34 20 6D 6D 0D 0A 43 4C 53 0D BARCODE 1 0A 42 41 52 43 4F 44 45 20 31 44,149,"39 34 34 2C 31 34 39 2C 22 3A 39 ",120,1,0. 22 2C 31 32 30 2C 31 2C 30 2C 2.6,"57114 32 2C 36 2C 22 35 37 31 31 34 38T" PRIN 33 38 54 22 0D 0A 50 52 49 4E T 1,1 SPE 54 20 31 2C 31 0D 0A 53 50 45 ED 2.0 DE 45 44 20 32 2E 30 0D 0A 44 45 NSITY 8 S 4E 53 49 54 59 20 38 0D 0A 53  ET PEEL OF 45 54 20 50 45 45 4C 20 4F 46 F DIRECTI 46 0D 0A 44 49 52 45 43 54 49 ON 0 GAP 4F 4E 20 30 0D 0A 47 41 50 20 3.00 mm,0. 33 2E 30 30 20 6D 6D 2C 30 2E 00 mm REF 30 30 20 6D 6D 0D 0A 52 45 46 ERENCE 0.0 45 52 45 4E 43 45 20 30 2C 30 SET CUTT 0D 0A 53 45 54 20 43 55 54 54 ER OFF SI 45 52 20 4F 46 46 0D 0A 53 49 ZE 100.02 5A 45 20 31 30 30 2E 30 32 20 mm,65.04 m 6D 6D 2C 36 35 2E 30 34 20 6D m CLS BA 6D 0D 0A 43 4C 53 0D 0A 42 41 RCODE 144. 52 43 4F 44 45 20 31 34 34 2C 149,"39",1 31 34 39 2C 22 33 39 22 2C 31 20,1,0,2,6 32 30 2C 31 2C 30 2C 32 2C 36 ,"5711438T 2C 22 35 37 31 31 34 33 38 54 " PRINT 1 22 0D 0A 50 52 49 4E 54 20 31 .1 2C 31 0D 0A </pre>	<p>Hex decimal data related to left column of ASCII data</p>
---------------------	--	--

Fig. 30 Dump mode printout

**Note:**

Turn off / on the power to resume printer for normal printing.

## 4.3 Printer Initialization

Printer initialization is used to clear DRAM and restore printer settings to defaults. The only one exception is ribbon sensitivity, which will not be restored to default.

Printer initialization is activated by the following procedures.

1. Turn off the power switch.
2. Hold on the button then turn on the power switch.
3. Release the button when LED turns **green** after 5 amber blinks. (Any green will do during the 5 blinks).
  - The LED color will be changed as following:  
Amber → red (5 blinks) → amber (5 blinks) → **green (5 blinks)** → green/amber (5 blinks) → red/amber (5 blinks) → solid green

Printer configuration will be restored to defaults as below after initialization.

Parameter	Default setting
Speed	127 mm/sec (5 ips) 76 mm/sec (3 ips)
Density	7
Label Width	4.25" (108.0 mm)
Label Height	2.5" (63.4 mm)
Sensor Type	Gap sensor
Gap Setting	0.12" (3.0 mm)
Print Direction	0
Reference Point	0,0 (upper left corner)
Offset	0
Tear Mode	On
Peel off Mode	Off
Cutter Mode	Off
Serial Port Settings	9600 bps, none parity, 8 data bits, 1 stop bit
Code Page	850
Country Code	001
Clear Flash Memory	No

**Note :**

**Always do gap/black mark sensor calibration after printer initialization.**

## 4.4 Black Mark Sensor Calibration

Set black mark sensor as media sensor and calibrate the black mark sensor.

Please follow the steps as below.

1. Turn off the power switch.
2. Hold on the button then turn on the power switch.
3. Release the button when LED turns **green/amber** after 5 green blinks. (Any green/amber will do during the 5 blinks).
  - The LED color will be changed as following:  
Amber → red (5 blinks) → amber (5 blinks) → green (5 blinks) → **green/amber (5 blinks)** → red/amber (5 blinks) → solid green

## 4.5 Gap Sensor Calibration

Set gap sensor as media sensor and calibrate the gap sensor.

Please follow the steps as below.

1. Turn off the power switch.
2. Hold on the button then turn on the power switch.
3. Release the button when LED turns **red/amber** after 5 green/amber blinks. (Any red/amber will do during the 5 blinks).
  - The LED color will be changed as following:  
Amber → red (5 blinks) → amber (5 blinks) → green (5 blinks) → **green/amber (5 blinks)** → red/amber (5 blinks) → solid green

## 4.6 Skip AUTO.BAS

TSPL2 programming language allows user to download an auto execution file to flash memory. Printer will run the AUTO.BAS program immediately when turning on printer power. The AUTO.BAS program can be interrupted without running the program by the power-on utility.

Please follow the procedures below to skip an AUTO.BAS program.

1. Turn off printer power.
2. Press the FEED button and then turn on power. The LED will become red, orange, green with 5 blinking (around 5 seconds) for each color.

3. Release the FEED button when LED becomes solid green.

The LED color will be changed as following pattern:

Orange → red (5 blinks) → orange (5 blinks) → green (5 blinks) → **solid green**

4. Printer will be interrupted to run the AUTO.BAS program.

## 5. Maintenance

### 5.1 Cleaning

Use one or more of the following supplies that meets your needs:

- Cleaning pens.
- Cleaning swabs
- Lint-free cloth.

The cleaning process is described as following

<b>Printer Part</b>	<b>Method</b>
Printer Head	<ul style="list-style-type: none"><li>■ Let the print head to cool for one minute.</li><li>■ Use a cleaning pen to swab the print elements.</li></ul>
Platen Roller	<ul style="list-style-type: none"><li>■ Rotate the platen roller and wipe it thoroughly with 70% alcohol and a cleaning swab, or lint-free cloth.</li></ul>
Exterior	<ul style="list-style-type: none"><li>■ Wipe it with water-dampened cloth.</li></ul>
Interior	<ul style="list-style-type: none"><li>■ Brush or air blow.</li></ul>

## 6. Troubleshooting

This section lists the common problems that according to the LED status and other problems you may encounter when operating the printer. Also, it provides solutions.

### 6.1 LED Status

LED Status / Color	Printer Status	Solution Number
Off	off	1
Solid Green	on	2
Green with blinking	Pause	3
Red with blinking	Stopped	4

#### 1. **No power.**

- Turn on the power switch.
- Check if the green LED is lit on power supply. If it is not lit on, power supply is broken.
- Check both power connection from the power cord to the power supply and from the power supply to the printer power jack.

#### 2. **The printer is on and ready to use.**

- No action necessary.

#### 3. **The printer is paused.**

- Press the feed button to resume printing.

#### 4. **The out of label or ribbon or the printer setting is not correct**

*Out of label or ribbon*

- Load a roll of label and follow the instructions in Loading the Paper then press the feed button to resume printing.
- Load a roll of ribbon and follow the instructions in Loading the Ribbon then press the feed button to resume printing.

*Printer setting is not correct*

- Initialize the printer by following the instructions in “Power on Utility”.



## 6.2 Print Quality

### *Continuous feeding labels*

- The printer setting may go wrong. Please do the **Initialization** and **Gap/Black Mark Calibration**.

### *No print on the label*

- Is the label or ribbon loaded correctly? Follow the instructions in **Loading the Paper** or **Loading the Ribbon**.
- Does the ribbon run out? Follow the instructions in **Loading the Ribbon**.

### *Poor print quality*

- Top cover is not closed properly. Close the top cover completely and make sure the right side and left side levers are latched to top cover properly.
- Clean the thermal print head.
- Adjust the print density setting.
- Ribbon and paper media are not compatible.

## 7. Specifications

### 7.1 Printer Specifications

Item	
<b>Mechanism</b>	
Resolution	203 dpi   300 dpi
Max. Print Width	108 mm   104 mm
Max. Print Length	1000 mm ( 39" )   420 mm (16.53")
Ribbon Capacity	300 meter with 1" core (Max. OD 67 mm)
Printing Speed	2, 3, 4 and 5 ips   2, 3 ips
Peeler function	2, 3 ips   2 ips
Printing Method	Direct thermal and thermal transfer printing.
<b>Enclosure</b>	
Structure	Double-walled plastic.
Dimension	Standard Model: 314mm(L) x 213mm(W) x 188mm(H)
Operation Panel	One push switch, and one indicator LED (Green, Orange, Red colors).
<b>Hardware</b>	
Sensor	Transmissive sensor (offset 6 mm from liner edge). Reflective sensor (position adjustable). Head open micro switch. Ribbon end sensor
Memory	2M byte Flash memory 2M bytes DRAM
Interface	RS-232C (max baud rate, 19,200 bps). USB: V1.1. Centronics.
Power	AC input: 100-240V universal auto switching power supply. DC output: 24V 3.75A.
<b>Firmware</b>	
Font Type	8 alpha-numeric bitmap fonts, and 1 true type font.
Rotation	0, 90,180 and 270 degrees.
Barcode Format	<b>1D Bar code</b> Code 39, Code 93, Code 128UCC, Code128 subsets A.B.C, Codabar, Interleave 2 of 5, EAN-8, EAN-13,

Command Set	EAN-128, UPC-A, UPC-E, EAN and UPC2(5) digits add-on, MSI, PLESSEY, POSTNET, ChinaPOST, ITF-14, EAN-14. 2D Bar code PDF-417, Maxicode, and DataMatrix, QR CODE. TSPL2
<b>Environment</b>	
Operation	Temperature: 5°C ~ 40°C. Relative Humidity: 25% ~ 85% (Non Condensing).
Storage	Temperature: -40°C ~ 60°C. Relative Humidity: 10% ~ 90% (Non Condensing).

## 7.2 Label Stock Specifications

Item	Specification
Type	Label (Continuous , Die-cut , Fan-fold).
Wound Type	Outside wound.
Width	20mm ~ 112mm (0.78" ~ 4.4").
Length	10mm ~ 1000mm (0.4" ~ 39"). 25.4mm ~ 1000mm (1" ~ 39").(for peeler and cutter)
Thickness	0.06mm ~ 0.19mm. (2.3~7.4 mil), max. 150g/m <sup>2</sup>
Roll Diameter	5".
Roll Core Diameter	25.4mm ~ 76.2mm (1" ~ 3").
Gap Height	2mm min.
Black Mark Height	2mm min.
Black Mark Width	8mm min.

## 7.3 Ribbon Specifications

Item	Specification
Type	Wax, Wax / Resin, Resin.
Core Diameter	1".
Width	Max 110mm.
Capacity	300m with 1" core.
Wound Type	Outside wound.
Ribbon End	Clear or silver end tape.

## 8. LED and Button Operation

### 8.1 LED

LED Color	Description
Green/ Solid	This illuminates that the power is on and the device is ready to use.
Green/ Flash	This illuminates that the system is downloading data from PC to memory and the printer is paused.
Amber	This illuminates that the system is clearing data from printer.
Red / Solid	This illuminates printer head open, cutter error.
Red / Flash	This illuminates a printing error, such as paper empty, paper jam, ribbon empty, or memory error etc.

### 8.2 Button Operation

<b>Feed</b>	<ul style="list-style-type: none"> <li>● Press the button when the LED is <b>green</b>.               <ul style="list-style-type: none"> <li>■ It feeds the label to the beginning of the next label.</li> </ul> </li> </ul>
<b>Pause</b>	<ul style="list-style-type: none"> <li>● Press the feed button during printing               <ul style="list-style-type: none"> <li>■ The printing job is suspended.</li> </ul> </li> </ul>
<b>Ribbon Sensor and Gap/Black Mark Sensor Calibration</b>	<ol style="list-style-type: none"> <li>1. Turn off the power switch.</li> <li>2. Hold on the button then turn on the power switch.</li> <li>3 Release the button when LED becomes <b>red</b> and blinking. (Any red will do during the 5 blinks).           <ul style="list-style-type: none"> <li>■ It will calibrate the ribbon sensor and gap/black mark sensor sensitivity.</li> <li>■ The LED color will be changed as following order : Amber → <b>red (5 blinks)</b> → amber (5 blinks) → green (5 blinks) → green/amber (5 blinks) → red/amber (5 blinks) → solid green</li> </ul> </li> </ol> <p><b>Note:</b> Please select gap or black mark sensor by <b>GAP</b> or <b>BLINE</b> command prior to calibrate the sensor. For more information about <b>GAP</b> and <b>BLINE</b> command, please refer to <b>TSPL2 programming manual</b>.</p>

<p><b>Gap/Black Mark Sensor Calibration, Label Length Measurement, Self Test and enter Dump Mode</b></p>	<ol style="list-style-type: none"> <li>1. Turn off the power switch.</li> <li>2. Hold on the button then turn on the power switch.</li> <li>3. Release the button when LED becomes <b>amber</b> and blinking. (Any amber will do during the 5 blinks). <ul style="list-style-type: none"> <li>■ The LED color will be changed as following order. Amber → red (5 blinks) → <b>amber (5 blinks)</b> → green (5 blinks) → green/amber (5 blinks) → red/amber (5 blinks) → solid green</li> <li>■ It calibrates the sensor and measures the label length and prints internal settings then enter the dump mode.</li> </ul> </li> </ol> <p><b>Note:</b>  <b>Please select gap or black mark sensor by GAP or BLINE command prior to calibrate the sensor.</b>  <b>For more information about GAP and BLINE command, please refer to TSPL2 programming manual.</b></p>
<p><b>Printer Initialization</b></p>	<ol style="list-style-type: none"> <li>1. Turn off the power switch.</li> <li>2. Hold on the button then turn on the power switch.</li> <li>3. Release the button when LED turns <b>green</b> after 5 amber blinks. (Any green will do during the 5 blinks). <ul style="list-style-type: none"> <li>■ The LED color will be changed as following: Amber → red (5 blinks) → amber (5 blinks) → <b>green (5 blinks)</b> → green/amber (5 blinks) → red/amber (5 blinks) → solid green</li> </ul> </li> </ol> <p><b>Note:</b>  <b>Always do gap/black mark sensor calibration after printer initialization.</b></p>
<p><b>Black Mark Sensor Calibration</b></p>	<ol style="list-style-type: none"> <li>1. Turn off the power switch.</li> <li>2. Hold on the button then turn on the power switch.</li> <li>3. Release the button when LED turns <b>green/amber</b> after 5 green blinks. (Any green/amber will do during the 5 blinks). <ul style="list-style-type: none"> <li>■ The LED color will be changed as following: Amber → red (5 blinks) → amber (5 blinks) → green (5 blinks) → <b>green/amber (5 blinks)</b> → red/amber (5 blinks) → solid green</li> </ul> </li> </ol>

<p><b>Gap Sensor Calibration</b></p>	<ol style="list-style-type: none"> <li>1. Turn off the power switch.</li> <li>2. Hold on the button then turn on the power switch.</li> <li>3. Release the button when LED turns <b>red/amber</b> after 5 green/amber blinks. (Any red/amber will do during the 5 blinks). <ul style="list-style-type: none"> <li>■ The LED color will be changed as following: Amber → red (5 blinks) → amber (5 blinks) → green (5 blinks) → green/amber (5 blinks) → <b>red/amber (5 blinks)</b> → solid green</li> </ul> </li> </ol>
<p><b>Skip AUTO.BAS</b></p>	<ol style="list-style-type: none"> <li>1. Turn off printer power.</li> <li>2. Press the FEED button and then turn on power.</li> <li>3. Release the FEED button when LED becomes <b>solid green</b>. <ul style="list-style-type: none"> <li>■ The LED color will be changed as following: Amber → red (5 blinks) → amber (5 blinks) → green (5 blinks) → green/amber (5 blinks) → red/amber (5 blinks) → <b>solid green</b></li> </ul> </li> <li>4. Printer will be interrupted to run the AUTO.BAS program.</li> </ol>

# Update History

Date	Content	Editor
2006/8/15	1. Modify to RoHS version.	Camille Pao
2006/9/25	1. Modify power on utilities section. 2. Modify LED and button operation section.	Camille Pao
2006/11/30	1. Modify power on utilities section.	Camille Pao

**Any changes or modifications not expressly approved by the party responsible for compliance could void the authority to operate equipment.**

This equipment has been tested and found to comply with the limits for a Class B digital device, pursuant to part 15 of the FCC Rules. These limits are designed to provide reasonable protection against harmful interference in a residential installation. This equipment generates, uses and can radiate radio frequency energy and, if not installed and used in accordance with the instructions, may cause harmful interference to radio communications. However, there is no guarantee that interference will not occur in a particular installation. If this equipment does cause harmful interference to radio or television reception, which can be determined by turning the equipment off and on, the user is encouraged to try to correct the interference by one or more of the following measures:

- Reorient or relocate the receiving antenna.
- Increase the separation between the equipment and receiver.
- Connect the equipment into an outlet on a circuit different from that to which the receiver is connected.
- Consult the dealer or an experienced radio/TV technician for help.



**Graphic Products, Inc.**