



Test Report

Product Name	Printer
Model No.	TSC-30B, CN-30B, BP-30B, PR30B, GR30B, 3300B, TSC-30RB, CN-30RB, BP-30RB, PR30RB, GR30RB, 3300RB, Alpha-3RB
FCC ID.	VTV0481201

Applicant	TSC Auto ID Technology Co., Ltd.
Address	9F., No. 95, Minquan Rd. Xindian Dist. New Taipei City 23141, Taiwan (R.O.C.)

Date of Receipt	Apr. 23, 2012
Issued Date	Jul. 18, 2012
Report No.	124450R-RFUSP29V01
Report Version	V1.0



The Test Results relate only to the samples tested.

The test report shall not be reproduced except in full without the written approval of Quietek Corporation.

This report must not be used to claim product endorsement by NVLAP any agency of the U.S. Government

Test Report Certification

Issued Date: Jul. 18, 2012

Report No.: 124450R-RFUSP29V01



Product Name	Printer
Applicant	TSC Auto ID Technology Co., Ltd.
Address	9F., No. 95, Minquan Rd. Xindian Dist. New Taipei City 23141, Taiwan (R.O.C.)
Manufacturer	TSC Auto ID Technology Co., Ltd.
Model No.	TSC-30B, CN-30B, BP-30B, PR30B, GR30B, 3300B, TSC-30RB, CN-30RB, BP-30RB, PR30RB, GR30RB, 3300RB, Alpha-3RB
FCC ID.	VTV0481201
EUT Rated Voltage	DC 7.4V (Power by Battery), DC 12V(Power by Adapter)
EUT Test Voltage	AC 120V/ 60Hz
Trade Name	TSC
Applicable Standard	FCC CFR Title 47 Part 15 Subpart C: 2010 ANSI C63.4: 2003
Test Result	Complied

The Test Results relate only to the samples tested.

The test report shall not be reproduced except in full without the written approval of QuietTek Corporation.

This report must not be used to claim product endorsement by NVLAP any agency of the U.S. Government

Documented By : Jinn Chen
(Senior Adm. Specialist / Jinn Chen)

Tested By : Jack Hsu
(Assistant Engineer / Jack Hsu)

Approved By : [Signature]
(Manager / Vincent Lin)

TABLE OF CONTENTS

Description	Page
1. GENERAL INFORMATION	5
1.1. EUT Description.....	5
1.2. Operational Description.....	8
1.3. Tested System Details.....	9
1.4. Configuration of Tested System	9
1.5. EUT Exercise Software	10
1.6. Test Facility	11
2. CONDUCTED EMISSION	12
2.1. Test Equipment.....	12
2.2. Test Setup	12
2.3. Limits.....	13
2.4. Test Procedure	13
2.5. Uncertainty	13
2.6. Test Result of Conducted Emission.....	14
3. PEAK POWER OUTPUT	20
3.1. Test Equipment.....	20
3.2. Test Setup	20
3.3. Limit	20
3.4. Test Procedure	20
3.5. Uncertainty	20
3.6. Test Result of Peak Power Output.....	21
4. RADIATED EMISSION	23
4.1. Test Equipment.....	23
4.2. Test Setup	23
4.3. Limits.....	24
4.4. Test Procedure	25
4.5. Uncertainty	25
4.6. Test Result of Radiated Emission.....	26
5. RF ANTENNA CONDUCTED TEST	40
5.1. Test Equipment.....	40
5.2. Test Setup	40
5.3. Limits.....	40
5.4. Test Procedure	40
5.5. Uncertainty	40
5.6. Test Result of RF Antenna Conducted Test.....	41
6. BAND EDGE	53
6.1. Test Equipment.....	53
6.2. Test Setup	54
6.3. Limit	55
6.4. Test Procedure	55
6.5. Uncertainty	55

6.6.	Test Result of Band Edge	56
7.	CHANNEL NUMBER.....	64
7.1.	Test Equipment	64
7.2.	Test Setup	64
7.3.	Limit	64
7.4.	Test Procedure	64
7.5.	Uncertainty	64
7.6.	Test Result of Channel Number.....	65
8.	CHANNEL SEPARATION.....	67
8.1.	Test Equipment	67
8.2.	Test Setup	67
8.3.	Limit	67
8.4.	Test Procedure	67
8.5.	Uncertainty	67
8.6.	Test Result of Channel Separation.....	68
9.	DWELL TIME.....	72
9.1.	Test Equipment	72
9.2.	Test Setup	72
9.3.	Limit	72
9.4.	Test Procedure	72
9.5.	Uncertainty	72
9.6.	Test Result of Dwell Time	73
10.	OCCUPIED BANDWIDTH	77
10.1.	Test Equipment	77
10.2.	Test Setup	77
10.3.	Limits.....	77
10.4.	Test Procedure	77
10.5.	Uncertainty	77
10.6.	Test Result of Occupied Bandwidth	78
11.	EMI REDUCTION METHOD DURING COMPLIANCE TESTING	84

Attachment 1: EUT Test Photographs

Attachment 2: EUT Detailed Photographs

1. GENERAL INFORMATION

1.1. EUT Description

Product Name	Printer
Trade Name	TSC
Model No.	TSC-30B, CN-30B, BP-30B, PR30B, GR30B, 3300B, TSC-30RB, CN-30RB, BP-30RB, PR30RB, GR30RB, 3300RB, Alpha-3RB
FCC ID.	VTV0481201
Frequency Range	2402 – 2480MHz
Channel Number	79
Type of Modulation	FHSS: GFSK(1Mbps) / π /4DQPSK(2Mbps) / 8DPSK(3Mbps)
Antenna Type	SMD
Channel Control	Auto
Antenna Gain	Refer to the table “Antenna List”
USB Cable	Shielded, 1.0m, with one ferrite core bonded.
RS-232 to USB Cable	Shielded, 1.0m
Power Adapter#1	MFR: Powertron Electronics Corp. (Trade Mark : Powertron), M/N: PA1015-2DU Input: AC 100-240V, 0.4A, 50-60Hz Output: AC 12V $\overline{=}$ 1.0A 12W Max Cable Out: Non-shielded, 1.2m, with one ferrite core bonded.
Power Adapter#2	MFR: Li Tone Electronics Co., LTD. (Trade Mark : L.T.E.), M/N: LTE12W-S2 Input: AC 100-240V, 1A, 50/60Hz Output: DC 12V $\overline{=}$ 1A MAX:12W Cable Out: Non-shielded, 1.8m, with one ferrite core bonded.
Power Adapter#3	MFR: Atech OEM Inc.(Trade Mark : OEM), M/N: ADS0128-W 120100 Input: AC 100-240V, 0.5A, 50-60Hz Output: DC 12V $\overline{=}$ 1.0A Cable Out: Non-shielded, 1.5m
Power Adapter#4 (Car Charger)	MFR: Atech OEM Inc.(Trade Mark : OEM), M/N: C11A-1215CD0-S0 Input: DC 12 ~ 24V Output: DC 12V $\overline{=}$ 1.5A(MAX) Cable Out: Non-shielded, 1.5m

Antenna List

No.	Manufacturer	Part No.	Antenna Type	Peak Gain
1	H&H Technology Co., Ltd	IADEA002420C	SMD	-1.42 dBi for 2.4 GHz

Note: The antenna of EUT is conform to FCC 15.203.

Frequency of Each Channel:

Channel	Frequency	Channel	Frequency	Channel	Frequency	Channel	Frequency
Channel 00:	2402 MHz	Channel 20:	2422 MHz	Channel 40:	2442 MHz	Channel 60:	2462 MHz
Channel 01:	2403 MHz	Channel 21:	2423 MHz	Channel 41:	2443 MHz	Channel 61:	2463 MHz
Channel 02:	2404 MHz	Channel 22:	2424 MHz	Channel 42:	2444 MHz	Channel 62:	2464 MHz
Channel 03:	2405 MHz	Channel 23:	2425 MHz	Channel 43:	2445 MHz	Channel 63:	2465 MHz
Channel 04:	2406 MHz	Channel 24:	2426 MHz	Channel 44:	2446 MHz	Channel 64:	2466 MHz
Channel 05:	2407 MHz	Channel 25:	2427 MHz	Channel 45:	2447 MHz	Channel 65:	2467 MHz
Channel 06:	2408 MHz	Channel 26:	2428 MHz	Channel 46:	2448 MHz	Channel 66:	2468 MHz
Channel 07:	2409 MHz	Channel 27:	2429 MHz	Channel 47:	2449 MHz	Channel 67:	2469 MHz
Channel 08:	2410 MHz	Channel 28:	2430 MHz	Channel 48:	2450 MHz	Channel 68:	2470 MHz
Channel 09:	2411 MHz	Channel 29:	2431 MHz	Channel 49:	2451 MHz	Channel 69:	2471 MHz
Channel 10:	2412 MHz	Channel 30:	2432 MHz	Channel 50:	2452 MHz	Channel 70:	2472 MHz
Channel 11:	2413 MHz	Channel 31:	2433 MHz	Channel 51:	2453 MHz	Channel 71:	2473 MHz
Channel 12:	2414 MHz	Channel 32:	2434 MHz	Channel 52:	2454 MHz	Channel 72:	2474 MHz
Channel 13:	2415 MHz	Channel 33:	2435 MHz	Channel 53:	2455 MHz	Channel 73:	2475 MHz
Channel 14:	2416 MHz	Channel 34:	2436 MHz	Channel 54:	2456 MHz	Channel 74:	2476 MHz
Channel 15:	2417 MHz	Channel 35:	2437 MHz	Channel 55:	2457 MHz	Channel 75:	2477 MHz
Channel 16:	2418 MHz	Channel 36:	2438 MHz	Channel 56:	2458 MHz	Channel 76:	2478 MHz
Channel 17:	2419 MHz	Channel 37:	2439 MHz	Channel 57:	2459 MHz	Channel 77:	2479 MHz
Channel 18:	2420 MHz	Channel 38:	2440 MHz	Channel 58:	2460 MHz	Channel 78:	2480 MHz
Channel 19:	2421 MHz	Channel 39:	2441 MHz	Channel 59:	2461 MHz		

Note:

1. The EUT is a Printer with a built-in 2.4GHz Bluetooth transceiver.
2. These tests were conducted on a sample for the purpose of demonstrating compliance of Bluetooth transmitter with Part 15 Subpart C Paragraph 15.247 for spread spectrum devices.
3. Each model through the pretest, only the worst case (Alpha-3RW :USB to RS232 Cable) is shown in the test report
4. Regarding to the operation frequency, the lowest, middle and highest frequency are selected to perform the test.
5. The EUT is including thirteen models and each models are different in product name and shown as below:

	Control Method	
	Shipment Control	Firmware Control
Model No.	Cable	Print Speed (Unit : ips)
Alpha-3RB	USB, RS-232	1.5, 2, 2.5, 3, 3.5, 4
TSC-30B	USB	1.5, 2, 3, 4
CN-30B	USB	2, 3, 3.5, 4
BP-30B	USB	2, 2.5, 3, 3.5, 4
PR30B	USB	2, 2.5, 3, 4
GR30B	USB	2, 3, 4
3300B	USB	1.5, 2, 3, 3.5, 4
TSC-30RB	RS-232	1.5, 2, 3, 4
CN-30RB	RS-232	2, 3, 3.5, 4
BP-30RB	RS-232	2, 2.5, 3, 3.5, 4
PR30RB	RS-232	2, 2.5, 3, 4
GR30RB	RS-232	2, 3, 4
3300RB	RS-232	1.5, 2, 3, 3.5, 4
(1)The different models of the system where the module is identical. (2)The different model with different Cable, but electrical characteristic and I/O Port are the same. (3) The print speed is firmware control		

Test Mode	Mode 1: Transmit - 1Mbps (GFSK) Mode 2: Transmit - 3Mbps (8DPSK)
-----------	---

1.3. Tested System Details

The types for all equipment, plus descriptions of all cables used in the tested system (including inserted cards) are:

	Product	Manufacturer	Model No.	Serial No.	Power Cord
1	Notebook PC	DELL	PPT	N/A	Non-Shielded, 0.8m
2	USB Mouse	DELL	MO56UC	G0X01JK0	N/A
3	Microphone & Earphone	PCHOME	N/A	N/A	N/A
4	DVD ROM	DELL	PD01S	N/A	N/A
5	Monitor	LG	W2261VT	907YHZK07373	Non-Shielded, 1.8m

Signal Cable Type	Signal cable Description
A	Mouse Cable
B	Microphone & Earphone Cable
C	USB to RS232 Cable
D	USB Cable
E	VGA Cable

1.4. Configuration of Tested System

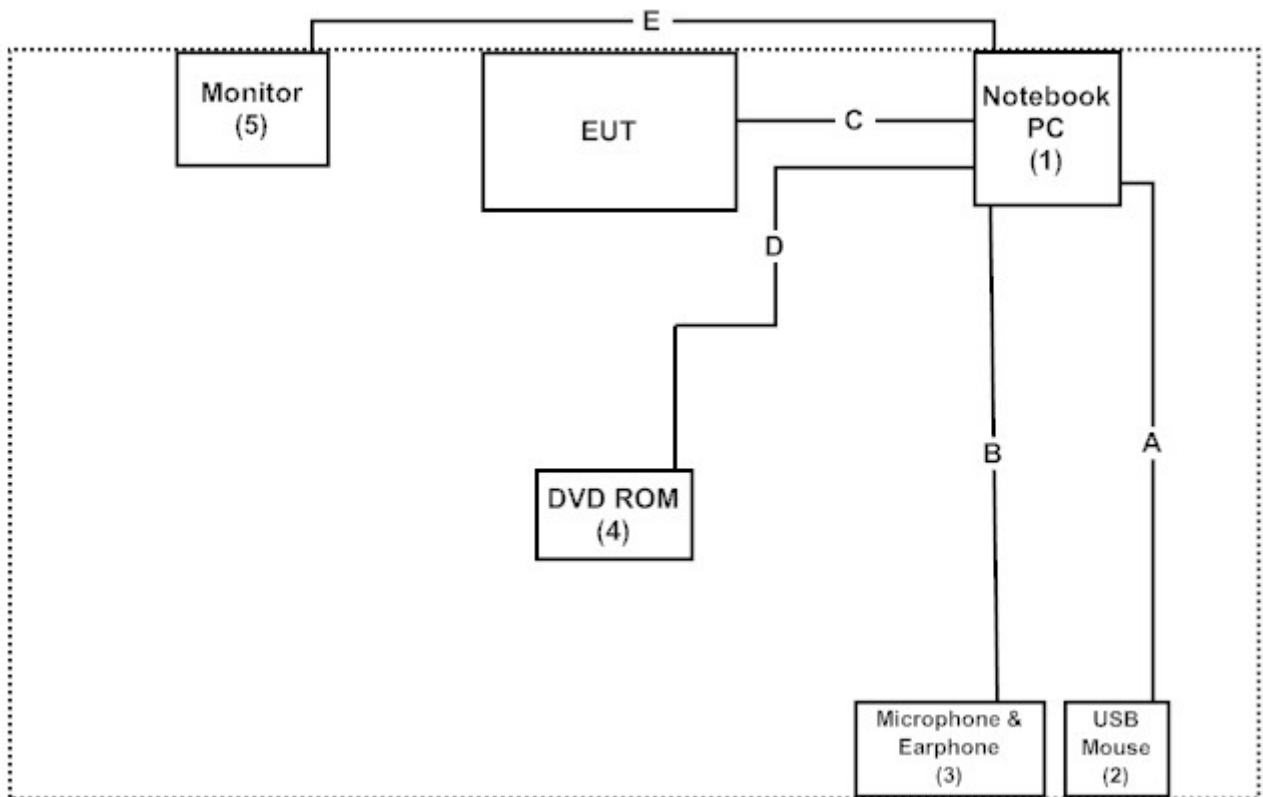

1.5. EUT Exercise Software

- (1) Setup the EUT as shown in Section 1.4
- (2) Execute program on the Notebook.
- (3) Configure the test mode, the test channel, and the data rate.
- (4) Start transmits continually.
- (5) Verify that the EUT works properly.

1.6. Test Facility

Ambient conditions in the laboratory:

Items	Required (IEC 68-1)	Actual
Temperature (°C)	15-35	20-35
Humidity (%RH)	25-75	30-65
Barometric pressure (mbar)	860-1060	950-1000

The related certificate for our laboratories about the test site and management system can be downloaded from Quietek Corporation's Web Site: <http://www.quietek.com/tw/ctg/cts/accreditations.htm>
The address and introduction of Quietek Corporation's laboratories can be founded in our Web site: <http://www.quietek.com/>

Site Description: File on
Federal Communications Commission
FCC Engineering Laboratory
7435 Oakland Mills Road
Columbia, MD 21046
Registration Number: 92195

Accreditation on NVLAP
NVLAP Lab Code: 200533-0

Site Name: Quietek Corporation
Site Address: No.5-22, Ruishukeng,
Linkou Dist. New Taipei City 24451,
Taiwan, R.O.C.
TEL: 886-2-8601-3788 / FAX : 886-2-8601-3789
E-Mail : service@quietek.com

FCC Accreditation Number: TW1014

2. Conducted Emission

2.1. Test Equipment

	Equipment	Manufacturer	Model No. / Serial No.	Last Cal.	Remark
X	Test Receiver	R & S	ESCS 30 / 825442/018	Sep., 2011	
X	Artificial Mains Network	R & S	ENV4200 / 848411/10	Feb., 2012	Peripherals
X	LISN	R & S	ESH3-Z5 / 825562/002	Feb., 2012	EUT
	DC LISN	Schwarzbeck	8226 / 176	Mar, 2012	EUT
X	Pulse Limiter	R & S	ESH3-Z2 / 357.8810.52	Feb., 2012	
	No.1 Shielded Room				

Note:

1. All equipments are calibrated every one year.
2. The test instruments marked by "X" are used to measure the final test results.

2.2. Test Setup

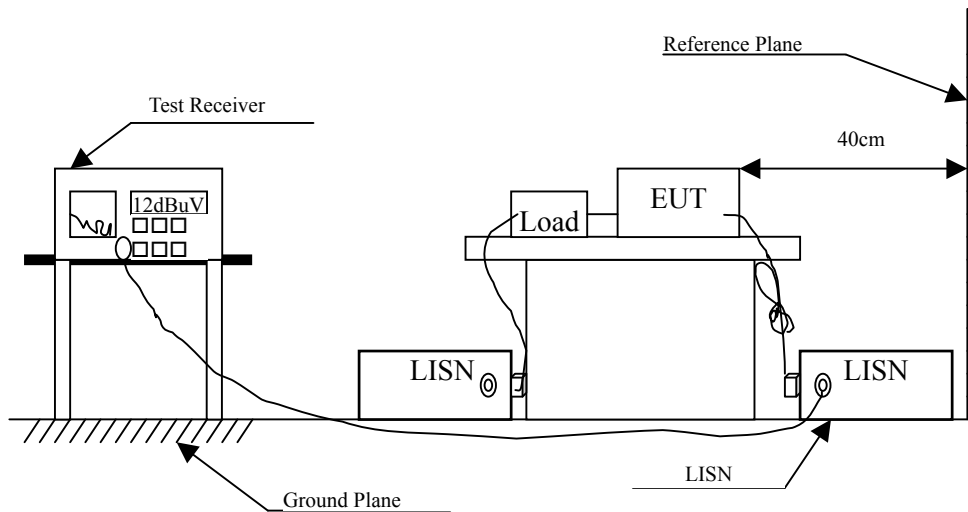

2.3. Limits

FCC Part 15 Subpart C Paragraph 15.207 (dBuV) Limit		
Frequency MHz	Limits	
	QP	AV
0.15 - 0.50	66-56	56-46
0.50-5.0	56	46
5.0 - 30	60	50

Remarks: In the above table, the tighter limit applies at the band edges.

2.4. Test Procedure

The EUT and Peripherals are connected to the main power through a line impedance stabilization network (L.I.S.N.). This provides a 50 ohm /50uH coupling impedance for the measuring equipment. The peripheral devices are also connected to the main power through a LISN that provides a 50ohm /50uH coupling impedance with 50ohm termination. (Please refer to the block diagram of the test setup and photographs.)

Both sides of A.C. line are checked for maximum conducted interference. In order to find the maximum emission, the relative positions of equipment and all the interface cables must be changed according to ANSI C63.4: 2003 on conducted measurement.

Conducted emissions were investigated over the frequency range from 0.15MHz to 30MHz using a receiver bandwidth of 9kHz.

The EUT was setup to ANSI C63.4, 2003; tested to FHSS test procedure of FCC Public Notice DA 00-705 for compliance to FCC 47CFR 15.247 requirements.

2.5. Uncertainty

± 2.26 dB

2.6. Test Result of Conducted Emission

Product : Printer
 Test Item : Conducted Emission Test
 Power Line : Line 1
 Test Mode : Mode 2: Transmit - 3Mbps (8DPSK) (2441MHz) +Adapter#1

Frequency MHz	Correct Factor dB	Reading Level dBuV	Measurement Level dBuV	Margin dB	Limit dBuV
LINE 1					
Quasi-Peak					
0.170	9.707	39.400	49.107	-16.322	65.429
0.279	9.647	29.100	38.747	-23.567	62.314
0.396	9.640	30.950	40.590	-18.381	58.971
3.955	9.700	21.540	31.240	-24.760	56.000
8.201	9.750	21.040	30.790	-29.210	60.000
25.998	9.960	22.860	32.820	-27.180	60.000
Average					
0.170	9.707	24.250	33.957	-21.472	55.429
0.279	9.647	18.020	27.667	-24.647	52.314
0.396	9.640	23.890	33.530	-15.441	48.971
3.955	9.700	14.340	24.040	-21.960	46.000
8.201	9.750	15.510	25.260	-24.740	50.000
25.998	9.960	22.030	31.990	-18.010	50.000

Note:

1. All Reading Levels are Quasi-Peak and average value.
2. "█" means the worst emission level.
3. Measurement Level = Reading Level + Correct Factor

Product : Printer
 Test Item : Conducted Emission Test
 Power Line : Line 2
 Test Mode : Mode 2: Transmit - 3Mbps (8DPSK) (2441MHz) +Adapter#1

Frequency MHz	Correct Factor dB	Reading Level dBuV	Measurement Level dBuV	Margin dB	Limit dBuV
LINE 2					
Quasi-Peak					
0.162	9.721	33.340	43.062	-22.595	65.657
0.224	9.670	30.300	39.970	-23.916	63.886
0.392	9.650	30.280	39.930	-19.156	59.086
0.470	9.650	25.570	35.220	-21.637	56.857
5.736	9.730	26.120	35.850	-24.150	60.000
25.998	10.190	22.480	32.670	-27.330	60.000
Average					
0.162	9.721	17.680	27.402	-28.255	55.657
0.224	9.670	24.790	34.460	-19.426	53.886
0.392	9.650	23.530	33.180	-15.906	49.086
0.470	9.650	18.310	27.960	-18.897	46.857
5.736	9.730	19.190	28.920	-21.080	50.000
25.998	10.190	21.510	31.700	-18.300	50.000

Note:

1. All Reading Levels are Quasi-Peak and average value.
2. "█" means the worst emission level.
3. Measurement Level = Reading Level + Correct Factor

Product : Printer
 Test Item : Conducted Emission Test
 Power Line : Line 1
 Test Mode : Mode 2: Transmit - 3Mbps (8DPSK) (2441MHz) +Adapter#2

Frequency MHz	Correct Factor dB	Reading Level dBuV	Measurement Level dBuV	Margin dB	Limit dBuV
LINE 1					
Quasi-Peak					
0.302	9.640	20.610	30.250	-31.407	61.657
0.388	9.640	34.140	43.780	-15.420	59.200
0.685	9.640	28.060	37.700	-18.300	56.000
0.943	9.670	26.970	36.640	-19.360	56.000
5.732	9.710	30.690	40.400	-19.600	60.000
11.865	9.820	21.720	31.540	-28.460	60.000
Average					
0.302	9.640	8.970	18.610	-33.047	51.657
0.388	9.640	29.250	38.890	-10.310	49.200
0.685	9.640	20.570	30.210	-15.790	46.000
0.943	9.670	17.740	27.410	-18.590	46.000
5.732	9.710	23.750	33.460	-16.540	50.000
11.865	9.820	15.610	25.430	-24.570	50.000

Note:

1. All Reading Levels are Quasi-Peak and average value.
2. "█" means the worst emission level.
3. Measurement Level = Reading Level + Correct Factor

Product : Printer
 Test Item : Conducted Emission Test
 Power Line : Line 2
 Test Mode : Mode 2: Transmit - 3Mbps (8DPSK) (2441MHz) +Adapter#2

Frequency MHz	Correct Factor dB	Reading Level dBuV	Measurement Level dBuV	Margin dB	Limit dBuV
LINE 2					
Quasi-Peak					
0.181	9.702	41.270	50.972	-14.142	65.114
0.236	9.662	33.000	42.662	-20.881	63.543
0.373	9.650	34.900	44.550	-15.079	59.629
0.986	9.690	26.050	35.740	-20.260	56.000
3.670	9.710	23.490	33.200	-22.800	56.000
5.900	9.740	23.050	32.790	-27.210	60.000
Average					
0.181	9.702	29.490	39.192	-15.922	55.114
0.236	9.662	19.230	28.892	-24.651	53.543
0.373	9.650	24.220	33.870	-15.759	49.629
0.986	9.690	17.600	27.290	-18.710	46.000
3.670	9.710	16.750	26.460	-19.540	46.000
5.900	9.740	16.570	26.310	-23.690	50.000

Note:

1. All Reading Levels are Quasi-Peak and average value.
2. "█" means the worst emission level.
3. Measurement Level = Reading Level + Correct Factor

Product : Printer
 Test Item : Conducted Emission Test
 Power Line : Line 1
 Test Mode : Mode 2: Transmit - 3Mbps (8DPSK) (2441MHz) +Adapter#3

Frequency MHz	Correct Factor dB	Reading Level dBuV	Measurement Level dBuV	Margin dB	Limit dBuV
LINE 1					
Quasi-Peak					
0.201	9.840	25.310	35.150	-29.393	64.543
0.322	9.840	18.460	28.300	-32.786	61.086
0.459	9.840	28.350	38.190	-18.981	57.171
1.130	9.850	23.530	33.380	-22.620	56.000
5.330	9.891	23.760	33.651	-26.349	60.000
29.728	10.104	12.640	22.744	-37.256	60.000
Average					
0.201	9.840	11.740	21.580	-32.963	54.543
0.322	9.840	8.960	18.800	-32.286	51.086
0.459	9.840	19.200	29.040	-18.131	47.171
1.130	9.850	2.100	11.950	-34.050	46.000
5.330	9.891	6.960	16.851	-33.149	50.000
29.728	10.104	1.820	11.924	-38.076	50.000

Note:

1. All Reading Levels are Quasi-Peak and average value.
2. "█" means the worst emission level.
3. Measurement Level = Reading Level + Correct Factor

Product : Printer
 Test Item : Conducted Emission Test
 Power Line : Line 2
 Test Mode : Mode 2: Transmit - 3Mbps (8DPSK) (2441MHz) +Adapter#3

Frequency MHz	Correct Factor dB	Reading Level dBuV	Measurement Level dBuV	Margin dB	Limit dBuV
LINE 2					
Quasi-Peak					
0.166	9.840	9.370	19.210	-46.333	65.543
0.205	9.840	24.990	34.830	-29.599	64.429
0.298	9.840	17.720	27.560	-34.211	61.771
0.498	9.840	22.350	32.190	-23.867	56.057
1.384	9.850	3.640	13.490	-42.510	56.000
9.474	10.040	7.870	17.910	-42.090	60.000
Average					
0.166	9.840	0.970	10.810	-44.733	55.543
0.205	9.840	13.490	23.330	-31.099	54.429
0.298	9.840	7.580	17.420	-34.351	51.771
0.498	9.840	18.300	28.140	-17.917	46.057
1.384	9.850	-2.380	7.470	-38.530	46.000
9.474	10.040	-1.610	8.430	-41.570	50.000

Note:

1. All Reading Levels are Quasi-Peak and average value.
2. "■" means the worst emission level.
3. Measurement Level = Reading Level + Correct Factor

3. Peak Power Output

3.1. Test Equipment

	Equipment	Manufacturer	Model No./Serial No.	Last Cal.
X	Power Meter	Anritsu	ML2495A/6K00003357	May, 2012
X	Power Sensor	Anritsu	MA2411B/0738448	Jun, 2012

Note: 1. All equipments are calibrated every one year.
 2. The test instruments marked by “X” are used to measure the final test results.

3.2. Test Setup

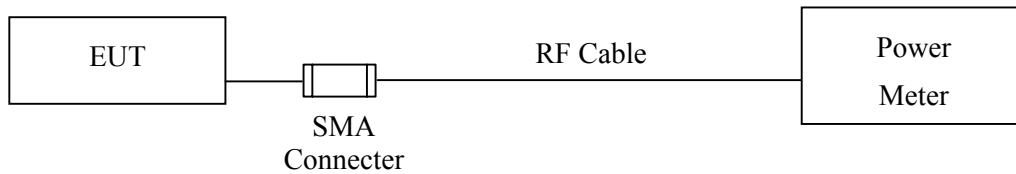

3.3. Limit

The maximum peak power shall be less 1Watt.

3.4. Test Procedure

The EUT was setup to ANSI C63.4, 2003; tested to FHSS test procedure of FCC Public Notice DA 00-705 for compliance to FCC 47CFR 15.247 requirements.

3.5. Uncertainty

± 1.27 dB

3.6. Test Result of Peak Power Output

Product : Printer
Test Item : Peak Power Output
Test Site : No.3 OATS
Test Mode : Mode 1: Transmit - 1Mbps (GFSK) +Adapter#2

Channel No.	Frequency (MHz)	Measurement (dBm)	Required Limit	Result
Channel 00	2402.00	0.14	1 Watt= 30 dBm	Pass
Channel 39	2441.00	0.87	1 Watt= 30 dBm	Pass
Channel 78	2480.00	0.79	1 Watt= 30 dBm	Pass

Product : Printer
Test Item : Peak Power Output
Test Site : No.3 OATS
Test Mode : Mode 2: Transmit - 3Mbps (8DPSK) +Adapter#2

Channel No.	Frequency (MHz)	Measurement (dBm)	Required Limit	Result
Channel 00	2402.00	-2.33	1 Watt= 30 dBm	Pass
Channel 39	2441.00	-2.84	1 Watt= 30 dBm	Pass
Channel 78	2480.00	-2.91	1 Watt= 30 dBm	Pass

4. Radiated Emission

4.1. Test Equipment

The following test equipments are used during the radiated emission test:

Test Site		Equipment	Manufacturer	Model No./Serial No.	Last Cal.
☒ Site # 3	X	Bilog Antenna	Schaffner Chase	CBL6112B/2673	Sep., 2011
	X	Horn Antenna	Schwarzbeck	BBHA9120D/D305	Sep., 2011
	X	Horn Antenna	Schwarzbeck	BBHA9170/208	Jul., 2012
	X	Pre-Amplifier	Agilent	8447D/2944A09549	Sep., 2011
	X	Spectrum Analyzer	Agilent	E4407B / US39440758	May, 2012
	X	Test Receiver	R & S	ESCS 30/ 825442/018	Sep., 2011
	X	Coaxial Cable	Quietek	QTK-CABLE/ CAB5	Feb., 2012
	X	Controller	Quietek	QTK-CONTROLLER/ CTRL3	N/A
	X	Coaxial Switch	Anritsu	MP59B/6200265729	N/A

- Note: 1. All equipments are calibrated every one year.
 2. The test instruments marked by "X" are used to measure the final test results.

4.2. Test Setup

Below 1GHz

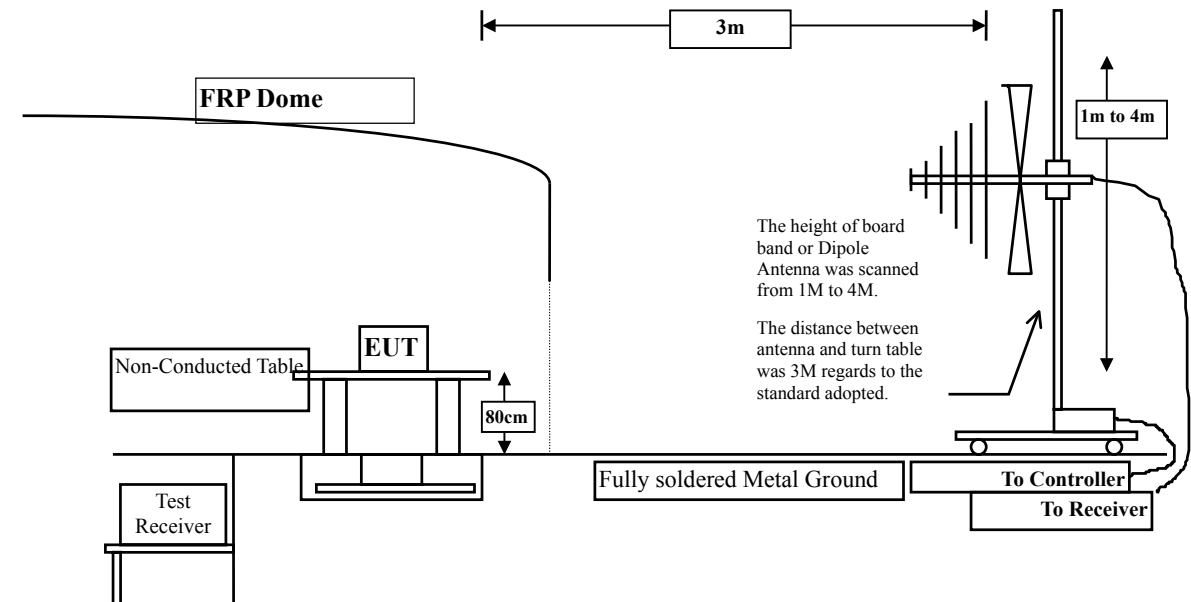

Above 1GHz

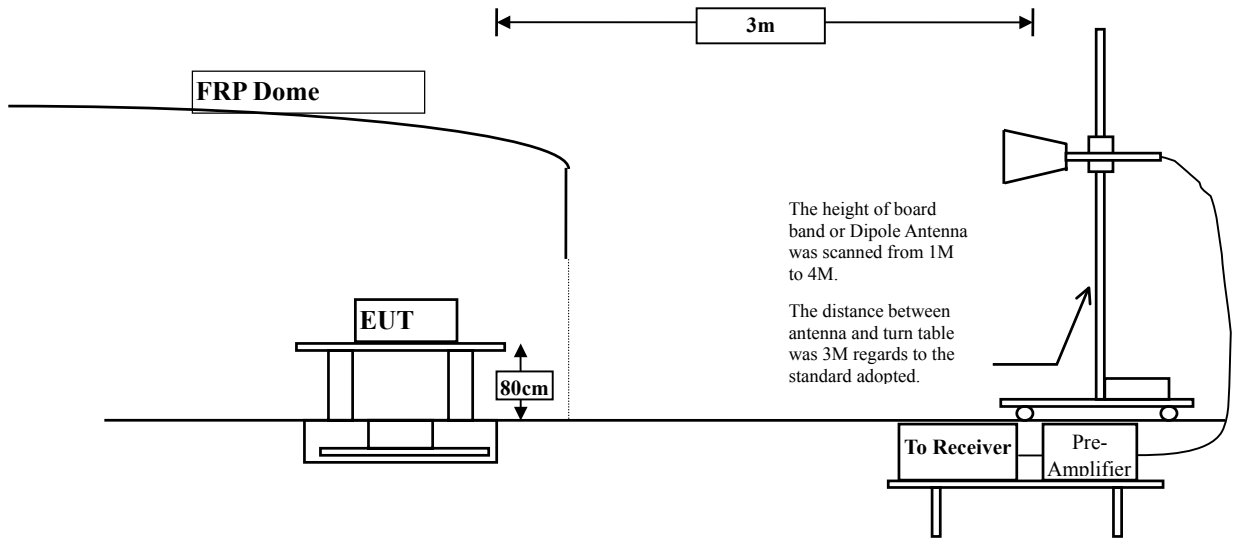

4.3. Limits

➤ General Radiated Emission Limits

Emissions radiated outside of the specified frequency bands, except for harmonics, shall be attenuated by at least 20dB below the level of the fundamental or to the general radiated emission limits in paragraph 15.209, whichever is the lesser attenuation.

FCC Part 15 Subpart C Paragraph 15.209 Limits		
Frequency MHz	uV/m @3m	dBuV/m@3m
30-88	100	40
88-216	150	43.5
216-960	200	46
Above 960	500	54

- Remarks:
1. RF Voltage (dBuV) = 20 log RF Voltage (uV)
 2. In the Above Table, the tighter limit applies at the band edges.
 3. Distance refers to the distance in meters between the measuring instrument antenna and the closed point of any part of the device or system.

4.4. Test Procedure

The EUT was setup according to ANSI C63.4, 2003 and tested according to FHSS test procedure of FCC Public Notice DA 00-705 for compliance to FCC 47CFR 15.247 requirements.

The EUT is placed on a turn table which is 0.8 meter above ground. The turn table is rotated 360 degrees to determine the position of the maximum emission level. The EUT was positioned such that the distance from antenna to the EUT was 3 meters.

The antenna is scanned from 1 meter to 4 meters to find out the maximum emission level. This is repeated for both horizontal and vertical polarization of the antenna. In order to find the maximum emission, all of the interface cables were manipulated according to ANSI C63.4:2003 on radiated measurement.

The resolution bandwidth below 1GHz setting on the field strength meter is 120 kHz and above 1GHz is 1MHz.

Radiated emission measurements below 1GHz are made using broadband Bilog antenna and above 1GHz are made using Horn Antennas.

The measurement is divided into the Preliminary Measurement and the Final Measurement.

The suspected frequencies are searched for in Preliminary Measurement with the measurement antenna kept pointed at the source of the emission both in azimuth and elevation, with the polarization of the antenna oriented for maximum response. The antenna is pointed at an angle towards the source of the emission, and the EUT is rotated in both height and polarization to maximize the measured emission. The emission is kept within the illumination area of the 3 dB bandwidth of the antenna.

The worst radiated emission is measured on the Final Measurement.

The measurement frequency range form 30MHz - 10th Harmonic of fundamental was investigated.

4.5. Uncertainty

± 3.9 dB above 1GHz

± 3.8 dB below 1GHz

4.6. Test Result of Radiated Emission

Product : Printer
 Test Item : Harmonic Radiated Emission
 Test Site : No.3 OATS
 Test Mode : Mode 1: Transmit - 1Mbps (GFSK)(2402MHz) +Adapter#2

Frequency MHz	Correct Factor dB	Reading Level dBuV	Measurement Level dBuV/m	Margin dB	Limit dBuV/m
Horizontal					
Peak Detector:					
4804.000	3.327	39.790	43.117	-30.883	74.000
7206.000	10.136	35.500	45.636	-28.364	74.000
9608.000	13.706	36.510	50.216	-23.784	74.000
Average Detector:					
--					
Vertical					
Peak Detector:					
4804.000	6.638	43.000	49.637	-24.363	74.000
7206.000	11.005	36.430	47.435	-26.565	74.000
9608.000	14.103	35.560	49.663	-24.337	74.000
Average Detector:					
--					

Note:

1. All Readings below 1GHz are Quasi-Peak, above 1GHz are performed with peak and/or average measurements as necessary.
2. Peak measurements: RBW = 1MHz, VBW = 3 MHz, Sweep: Auto.
3. Average measurements: RBW = 1MHz, VBW = 10 Hz, Sweep: Auto.
4. Measurement Level = Reading Level + Correct Factor.
5. Correct Factor = Antenna factor + Cable loss – Amplifier gain.
6. The average measurement was not performed when the peak measured data under the limit of average detection.
7. The emission levels of other frequencies are very lower than the limit and not show in test report.

Product : Printer
 Test Item : Harmonic Radiated Emission
 Test Site : No.3 OATS
 Test Mode : Mode 1: Transmit - 1Mbps (GFSK)(2441MHz) +Adapter#2

Frequency MHz	Correct Factor dB	Reading Level dBuV	Measurement Level dBuV/m	Margin dB	Limit dBuV/m
Horizontal					
Peak Detector:					
4882.000	3.001	38.240	41.241	-32.759	74.000
7323.000	11.846	35.070	46.917	-27.083	74.000
9764.000	12.563	38.080	50.643	-23.357	74.000
Average Detector:					
--					
Vertical					
Peak Detector:					
4882.000	5.713	41.300	47.014	-26.986	74.000
7323.000	12.727	35.300	48.028	-25.972	74.000
9764.000	13.028	36.270	49.298	-24.702	74.000
Average Detector:					
--					

Note:

- All Readings below 1GHz are Quasi-Peak, above 1GHz are performed with peak and/or average measurements as necessary.
- Peak measurements: RBW = 1MHz, VBW = 3 MHz, Sweep: Auto.
- Average measurements: RBW = 1MHz, VBW = 10 Hz, Sweep: Auto.
- Measurement Level = Reading Level + Correct Factor.
- Correct Factor = Antenna factor + Cable loss – Amplifier gain.
- The average measurement was not performed when the peak measured data under the limit of average detection.
- The emission levels of other frequencies are very lower than the limit and not show in test report.

Product : Printer
 Test Item : Harmonic Radiated Emission
 Test Site : No.3 OATS
 Test Mode : Mode 1: Transmit - 1Mbps (GFSK)(2480MHz) +Adapter#2

Frequency MHz	Correct Factor dB	Reading Level dBuV	Measurement Level dBuV/m	Margin dB	Limit dBuV/m
Horizontal					
Peak Detector:					
4960.000	2.760	41.220	43.980	-30.020	74.000
7440.000	12.567	34.620	47.186	-26.814	74.000
9920.000	13.456	36.700	50.156	-23.844	74.000
Average Detector:					
--					
Vertical					
Peak Detector:					
4960.000	5.557	41.950	47.507	-26.493	74.000
7440.000	13.426	34.690	48.115	-25.885	74.000
9920.000	13.958	36.130	50.088	-23.912	74.000
Average Detector:					
--					

Note:

1. All Readings below 1GHz are Quasi-Peak, above 1GHz are performed with peak and/or average measurements as necessary.
2. Peak measurements: RBW = 1MHz, VBW = 3 MHz, Sweep: Auto.
3. Average measurements: RBW = 1MHz, VBW = 10 Hz, Sweep: Auto.
4. Measurement Level = Reading Level + Correct Factor.
5. Correct Factor = Antenna factor + Cable loss – Amplifier gain.
6. The average measurement was not performed when the peak measured data under the limit of average detection.
7. The emission levels of other frequencies are very lower than the limit and not show in test report.

Product : Printer
 Test Item : Harmonic Radiated Emission
 Test Site : No.3 OATS
 Test Mode : Mode 2: Transmit - 3Mbps (8DPSK)(2402MHz) +Adapter#2

Frequency MHz	Correct Factor dB	Reading Level dBuV	Measurement Level dBuV/m	Margin dB	Limit dBuV/m
Horizontal					
Peak Detector:					
4804.000	3.327	36.400	39.727	-34.273	74.000
7206.000	10.136	36.680	46.816	-27.184	74.000
9608.000	13.706	36.850	50.556	-23.444	74.000
Average Detector:					
--					
Vertical					
Peak Detector:					
4804.000	6.638	37.110	43.747	-30.253	74.000
7206.000	11.005	35.880	46.885	-27.115	74.000
9608.000	14.103	35.790	49.893	-24.107	74.000
Average Detector:					
--					

Note:

1. All Readings below 1GHz are Quasi-Peak, above 1GHz are performed with peak and/or average measurements as necessary.
2. Peak measurements: RBW = 1MHz, VBW = 3 MHz, Sweep: Auto.
3. Average measurements: RBW = 1MHz, VBW = 10 Hz, Sweep: Auto.
4. Measurement Level = Reading Level + Correct Factor.
5. Correct Factor = Antenna factor + Cable loss –Amplifier gain.
6. The average measurement was not performed when the peak measured data under the limit of average detection.
7. The emission levels of other frequencies are very lower than the limit and not show in test report.

Product : Printer
 Test Item : Harmonic Radiated Emission
 Test Site : No.3 OATS
 Test Mode : Mode 2: Transmit - 3Mbps (8DPSK) (2441MHz) +Adapter#2

Frequency MHz	Correct Factor dB	Reading Level dBuV	Measurement Level dBuV/m	Margin dB	Limit dBuV/m
Horizontal					
Peak Detector:					
4882.000	3.001	36.930	39.931	-34.069	74.000
7323.000	11.846	35.090	46.937	-27.063	74.000
9764.000	12.563	36.920	49.483	-24.517	74.000
Average Detector:					
--					
Vertical					
Peak Detector:					
4882.000	5.713	37.050	42.764	-31.236	74.000
7323.000	12.727	35.240	47.968	-26.032	74.000
9764.000	13.028	37.590	50.618	-23.382	74.000
Average Detector:					
--					

Note:

1. All Readings below 1GHz are Quasi-Peak, above 1GHz are performed with peak and/or average measurements as necessary.
2. Peak measurements: RBW = 1MHz, VBW = 3 MHz, Sweep: Auto.
3. Average measurements: RBW = 1MHz, VBW = 10 Hz, Sweep: Auto.
4. Measurement Level = Reading Level + Correct Factor.
5. Correct Factor = Antenna factor + Cable loss –Amplifier gain.
6. The average measurement was not performed when the peak measured data under the limit of average detection.
7. The emission levels of other frequencies are very lower than the limit and not show in test report.

Product : Printer
 Test Item : Harmonic Radiated Emission
 Test Site : No.3 OATS
 Test Mode : Mode 2: Transmit - 3Mbps (8DPSK) (2480MHz) +Adapter#2

Frequency MHz	Correct Factor dB	Reading Level dBuV	Measurement Level dBuV/m	Margin dB	Limit dBuV/m
Horizontal					
Peak Detector:					
4960.000	2.760	36.860	39.620	-34.380	74.000
7440.000	12.567	34.890	47.456	-26.544	74.000
9920.000	13.456	35.680	49.136	-24.864	74.000
Average Detector:					
--					
Vertical					
Peak Detector:					
4960.000	5.557	36.790	42.347	-31.653	74.000
7440.000	13.426	34.950	48.375	-25.625	74.000
9920.000	13.958	36.600	50.558	-23.442	74.000
Average Detector:					
--					

Note:

1. All Readings below 1GHz are Quasi-Peak, above 1GHz are performed with peak and/or average measurements as necessary.
2. Peak measurements: RBW = 1MHz, VBW = 3 MHz, Sweep: Auto.
3. Average measurements: RBW = 1MHz, VBW = 10 Hz, Sweep: Auto.
4. Measurement Level = Reading Level + Correct Factor.
5. Correct Factor = Antenna factor + Cable loss – Amplifier gain.
6. The average measurement was not performed when the peak measured data under the limit of average detection.
7. The emission levels of other frequencies are very lower than the limit and not show in test report.

Product : Printer
 Test Item : General Radiated Emission
 Test Site : No.3 OATS
 Test Mode : Mode 1: Transmit - 1Mbps (GFSK) (2441MHz) +Adapter#1

Frequency MHz	Correct Factor dB	Reading Level dBuV	Measurement Level dBuV/m	Margin dB	Limit dBuV/m
Horizontal					
398.600	-2.268	31.253	28.985	-17.015	46.000
497.540	-0.273	33.181	32.908	-13.092	46.000
598.420	3.991	27.986	31.977	-14.023	46.000
697.360	3.171	31.460	34.631	-11.369	46.000
806.000	4.968	32.987	37.955	-8.045	46.000
897.180	5.182	29.249	34.431	-11.569	46.000
Vertical					
398.600	-4.678	35.042	30.364	-15.636	46.000
497.540	-1.393	32.886	31.493	-14.507	46.000
598.420	-2.979	33.193	30.214	-15.786	46.000
697.360	1.311	33.144	34.455	-11.545	46.000
798.240	2.808	32.837	35.645	-10.355	46.000
897.180	2.332	29.637	31.969	-14.031	46.000

Note:

1. All Readings below 1GHz are Quasi-Peak, above 1GHz are performed with peak and/or average measurements as necessary.
2. Peak measurements: RBW = 1MHz, VBW = 3 MHz, Sweep: Auto.
3. Average measurements: RBW = 1MHz, VBW = 10 Hz, Sweep: Auto.
4. Measurement Level = Reading Level + Correct Factor.
5. Correct Factor = Antenna factor + Cable loss – Amplifier gain.
6. The average measurement was not performed when the peak measured data under the limit of average detection.
7. The emission levels of other frequencies are very lower than the limit and not show in test report.

Product : Printer
 Test Item : General Radiated Emission
 Test Site : No.3 OATS
 Test Mode : Mode 2: Transmit - 3Mbps (8DPSK) (2441MHz) +Adapter#1

Frequency MHz	Correct Factor dB	Reading Level dBuV	Measurement Level dBuV/m	Margin dB	Limit dBuV/m
Horizontal					
398.600	-2.268	31.529	29.261	-16.739	46.000
497.540	-0.273	32.233	31.960	-14.040	46.000
598.420	3.991	27.694	31.685	-14.315	46.000
697.360	3.171	31.694	34.865	-11.135	46.000
806.000	4.968	32.069	37.037	-8.963	46.000
897.180	5.182	29.400	34.582	-11.418	46.000
Vertical					
99.840	-0.021	30.666	30.645	-12.855	43.500
398.600	-4.678	34.634	29.956	-16.044	46.000
497.540	-1.393	33.196	31.803	-14.197	46.000
697.360	1.311	33.659	34.970	-11.030	46.000
798.240	2.808	32.754	35.562	-10.438	46.000
897.180	2.332	28.936	31.268	-14.732	46.000

Note:

1. All Readings below 1GHz are Quasi-Peak, above 1GHz are performed with peak and/or average measurements as necessary.
2. Peak measurements: RBW = 1MHz, VBW = 3 MHz, Sweep: Auto.
3. Average measurements: RBW = 1MHz, VBW = 10 Hz, Sweep: Auto.
4. Measurement Level = Reading Level + Correct Factor.
5. Correct Factor = Antenna factor + Cable loss – Amplifier gain.
6. The average measurement was not performed when the peak measured data under the limit of average detection.
7. The emission levels of other frequencies are very lower than the limit and not show in test report.

Product : Printer
 Test Item : General Radiated Emission
 Test Site : No.3 OATS
 Test Mode : Mode 1: Transmit - 1Mbps (GFSK) (2441MHz) +Adapter#2

Frequency MHz	Correct Factor dB	Reading Level dBuV	Measurement Level dBuV/m	Margin dB	Limit dBuV/m
Horizontal					
249.220	-6.014	41.526	35.512	-10.488	46.000
299.660	-3.585	39.981	36.396	-9.604	46.000
398.600	-2.268	36.617	34.349	-11.651	46.000
460.680	1.589	32.753	34.342	-11.658	46.000
701.240	2.668	31.891	34.559	-11.441	46.000
901.060	5.591	34.439	40.030	-5.970	46.000
Vertical					
198.780	-8.221	40.824	32.603	-10.897	43.500
398.600	-4.678	39.072	34.394	-11.606	46.000
499.480	-0.852	33.235	32.383	-13.617	46.000
751.680	2.850	35.526	38.376	-7.624	46.000
901.060	3.331	37.063	40.394	-5.606	46.000
967.020	8.071	28.801	36.872	-17.128	54.000

Note:

1. All Readings below 1GHz are Quasi-Peak, above 1GHz are performed with peak and/or average measurements as necessary.
2. Peak measurements: RBW = 1MHz, VBW = 3 MHz, Sweep: Auto.
3. Average measurements: RBW = 1MHz, VBW = 10 Hz, Sweep: Auto.
4. Measurement Level = Reading Level + Correct Factor.
5. Correct Factor = Antenna factor + Cable loss – Amplifier gain.
6. The average measurement was not performed when the peak measured data under the limit of average detection.
7. The emission levels of other frequencies are very lower than the limit and not show in test report.

Product : Printer
 Test Item : General Radiated Emission
 Test Site : No.3 OATS
 Test Mode : Mode 2: Transmit - 3Mbps (8DPSK) (2441MHz) +Adapter#2

Frequency MHz	Correct Factor dB	Reading Level dBuV	Measurement Level dBuV/m	Margin dB	Limit dBuV/m
Horizontal					
299.660	-3.585	40.059	36.474	-9.526	46.000
460.680	1.589	33.590	35.179	-10.821	46.000
600.360	3.977	30.714	34.691	-11.309	46.000
848.680	5.776	34.007	39.782	-6.218	46.000
901.060	5.591	34.109	39.700	-6.300	46.000
949.560	6.695	28.858	35.553	-10.447	46.000
Vertical					
249.220	-7.634	41.801	34.167	-11.833	46.000
398.600	-4.678	38.820	34.142	-11.858	46.000
499.480	-0.852	33.504	32.652	-13.348	46.000
751.680	2.850	35.259	38.109	-7.891	46.000
899.120	3.063	37.138	40.201	-5.799	46.000
967.020	8.071	28.578	36.649	-17.351	54.000

Note:

1. All Readings below 1GHz are Quasi-Peak, above 1GHz are performed with peak and/or average measurements as necessary.
2. Peak measurements: RBW = 1MHz, VBW = 3 MHz, Sweep: Auto.
3. Average measurements: RBW = 1MHz, VBW = 10 Hz, Sweep: Auto.
4. Measurement Level = Reading Level + Correct Factor.
5. Correct Factor = Antenna factor + Cable loss – Amplifier gain.
6. The average measurement was not performed when the peak measured data under the limit of average detection.
7. The emission levels of other frequencies are very lower than the limit and not show in test report.

Product : Printer
 Test Item : General Radiated Emission
 Test Site : No.3 OATS
 Test Mode : Mode 1: Transmit - 1Mbps (GFSK) (2441MHz) +Adapter#3

Frequency MHz	Correct Factor dB	Reading Level dBuV	Measurement Level dBuV/m	Margin dB	Limit dBuV/m
Horizontal					
200.720	-10.595	30.140	19.545	-23.955	43.500
398.600	-2.268	32.353	30.085	-15.915	46.000
497.540	-0.273	35.176	34.903	-11.097	46.000
598.420	3.991	27.768	31.759	-14.241	46.000
697.360	3.171	31.346	34.517	-11.483	46.000
806.000	4.968	29.075	34.043	-11.957	46.000
Vertical					
198.780	-8.221	33.356	25.135	-18.365	43.500
297.720	-7.143	31.810	24.668	-21.332	46.000
497.540	-1.393	32.473	31.080	-14.920	46.000
697.360	1.311	32.919	34.230	-11.770	46.000
897.180	2.332	28.487	30.819	-15.181	46.000
967.020	6.921	24.345	31.266	-22.734	54.000

Note:

1. All Readings below 1GHz are Quasi-Peak, above 1GHz are performed with peak and/or average measurements as necessary.
2. Peak measurements: RBW = 1MHz, VBW = 3 MHz, Sweep: Auto.
3. Average measurements: RBW = 1MHz, VBW = 10 Hz, Sweep: Auto.
4. Measurement Level = Reading Level + Correct Factor.
5. Correct Factor = Antenna factor + Cable loss – Amplifier gain.
6. The average measurement was not performed when the peak measured data under the limit of average detection.
7. The emission levels of other frequencies are very lower than the limit and not show in test report.

Product : Printer
 Test Item : General Radiated Emission
 Test Site : No.3 OATS
 Test Mode : Mode 2: Transmit - 3Mbps (8DPSK) (2441MHz) +Adapter#3

Frequency MHz	Correct Factor dB	Reading Level dBuV	Measurement Level dBuV/m	Margin dB	Limit dBuV/m
Horizontal					
90.140	-9.449	36.174	26.725	-16.775	43.500
297.720	-3.633	29.121	25.489	-20.511	46.000
398.600	-2.268	32.789	30.521	-15.479	46.000
497.540	-0.273	34.602	34.329	-11.671	46.000
596.480	4.017	27.644	31.661	-14.339	46.000
697.360	3.171	31.267	34.438	-11.562	46.000
Vertical					
198.780	-8.221	31.229	23.008	-20.492	43.500
297.720	-7.143	31.661	24.519	-21.481	46.000
398.600	-4.678	34.721	30.043	-15.957	46.000
497.540	-1.393	32.676	31.283	-14.717	46.000
598.420	-2.979	32.145	29.166	-16.834	46.000
697.360	1.311	32.174	33.485	-12.515	46.000

Note:

1. All Readings below 1GHz are Quasi-Peak, above 1GHz are performed with peak and/or average measurements as necessary.
2. Peak measurements: RBW = 1MHz, VBW = 3 MHz, Sweep: Auto.
3. Average measurements: RBW = 1MHz, VBW = 10 Hz, Sweep: Auto.
4. Measurement Level = Reading Level + Correct Factor.
5. Correct Factor = Antenna factor + Cable loss – Amplifier gain.
6. The average measurement was not performed when the peak measured data under the limit of average detection.
7. The emission levels of other frequencies are very lower than the limit and not show in test report.

Product : Printer
 Test Item : General Radiated Emission
 Test Site : No.3 OATS
 Test Mode : Mode 1: Transmit - 1Mbps (GFSK) (2441MHz) +Adapter#4

Frequency MHz	Correct Factor dB	Reading Level dBuV	Measurement Level dBuV/m	Margin dB	Limit dBuV/m
Horizontal					
198.780	-10.661	30.841	20.180	-23.320	43.500
297.720	-3.633	30.711	27.079	-18.921	46.000
398.600	-2.268	32.266	29.998	-16.002	46.000
596.480	4.017	28.659	32.676	-13.324	46.000
796.300	5.161	27.606	32.767	-13.233	46.000
897.180	5.182	28.268	33.450	-12.550	46.000
Vertical					
198.780	-8.221	33.490	25.269	-18.231	43.500
297.720	-7.143	31.684	24.542	-21.458	46.000
365.620	-2.179	27.903	25.724	-20.276	46.000
460.680	-3.221	25.460	22.239	-23.761	46.000
596.480	-3.113	33.050	29.937	-16.063	46.000
749.740	2.510	28.755	31.265	-14.735	46.000

Note:

1. All Readings below 1GHz are Quasi-Peak, above 1GHz are performed with peak and/or average measurements as necessary.
2. Peak measurements: RBW = 1MHz, VBW = 3 MHz, Sweep: Auto.
3. Average measurements: RBW = 1MHz, VBW = 10 Hz, Sweep: Auto.
4. Measurement Level = Reading Level + Correct Factor.
5. Correct Factor = Antenna factor + Cable loss – Amplifier gain.
6. The average measurement was not performed when the peak measured data under the limit of average detection.
7. The emission levels of other frequencies are very lower than the limit and not show in test report.

Product : Printer
 Test Item : General Radiated Emission
 Test Site : No.3 OATS
 Test Mode : Mode 2: Transmit - 3Mbps (8DPSK) (2441MHz) +Adapter#4

Frequency MHz	Correct Factor dB	Reading Level dBuV	Measurement Level dBuV/m	Margin dB	Limit dBuV/m
Horizontal					
198.780	-10.661	29.952	19.291	-24.209	43.500
297.720	-3.633	28.755	25.123	-20.877	46.000
497.540	-0.273	36.676	36.403	-9.597	46.000
598.420	3.991	28.726	32.717	-13.283	46.000
697.360	3.171	29.906	33.077	-12.923	46.000
897.180	5.182	27.832	33.014	-12.986	46.000
Vertical					
198.780	-8.221	32.181	23.960	-19.540	43.500
249.220	-7.634	31.082	23.448	-22.552	46.000
344.280	-3.171	29.950	26.780	-19.220	46.000
596.480	-3.113	32.251	29.138	-16.862	46.000
749.740	2.510	29.642	32.152	-13.848	46.000
844.800	3.181	25.210	28.391	-17.609	46.000

Note:

1. All Readings below 1GHz are Quasi-Peak, above 1GHz are performed with peak and/or average measurements as necessary.
2. Peak measurements: RBW = 1MHz, VBW = 3 MHz, Sweep: Auto.
3. Average measurements: RBW = 1MHz, VBW = 10 Hz, Sweep: Auto.
4. Measurement Level = Reading Level + Correct Factor.
5. Correct Factor = Antenna factor + Cable loss – Amplifier gain.
6. The average measurement was not performed when the peak measured data under the limit of average detection.
7. The emission levels of other frequencies are very lower than the limit and not show in test report.

5. RF Antenna Conducted Test

5.1. Test Equipment

	Equipment	Manufacturer	Model No./Serial No.	Last Cal.
	Spectrum Analyzer	R&S	FSP40 / 100170	Jun, 2012
	Spectrum Analyzer	Agilent	E4407B / US39440758	Jun, 2012
X	Spectrum Analyzer	Agilent	N9010A / MY48030495	Apr., 2012

Note: 1. All equipments are calibrated every one year.
 2. The test instruments Marked “X” are used to measure the final test results.

5.2. Test Setup

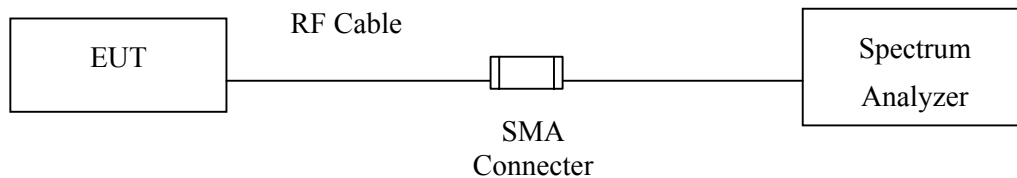

5.3. Limits

According to FCC Section 15.247(d). In any 100 kHz bandwidth outside the frequency band in which the spread spectrum or digitally modulated intentional radiator is operating, the radio frequency power that is produced by the intentional radiator shall be at least 20 dB below that in the 100 kHz bandwidth within the band that contains the highest level of the desired power, based on either an RF conducted or measurement, provided the transmitter demonstrates compliance with the peak conducted power limits. If the transmitter complies with the conducted power limits based on the use of RMS averaging over a time interval, the attenuation required under this paragraph shall be 30 dB instead of 20 dB.

5.4. Test Procedure

The EUT was setup to ANSI C63.4, 2003; tested to FHSS test procedure of FCC Public Notice DA 00-705 for compliance to FCC 47CFR 15.247 requirements.

5.5. Uncertainty

± 150Hz

5.6. Test Result of RF Antenna Conducted Test

Product : Printer
 Test Item : RF Antenna Conducted Test
 Test Site : No.3 OATS
 Test Mode : Mode 1: Transmit - 1Mbps (GFSK) +Adapter#2

Figure Channel 00:

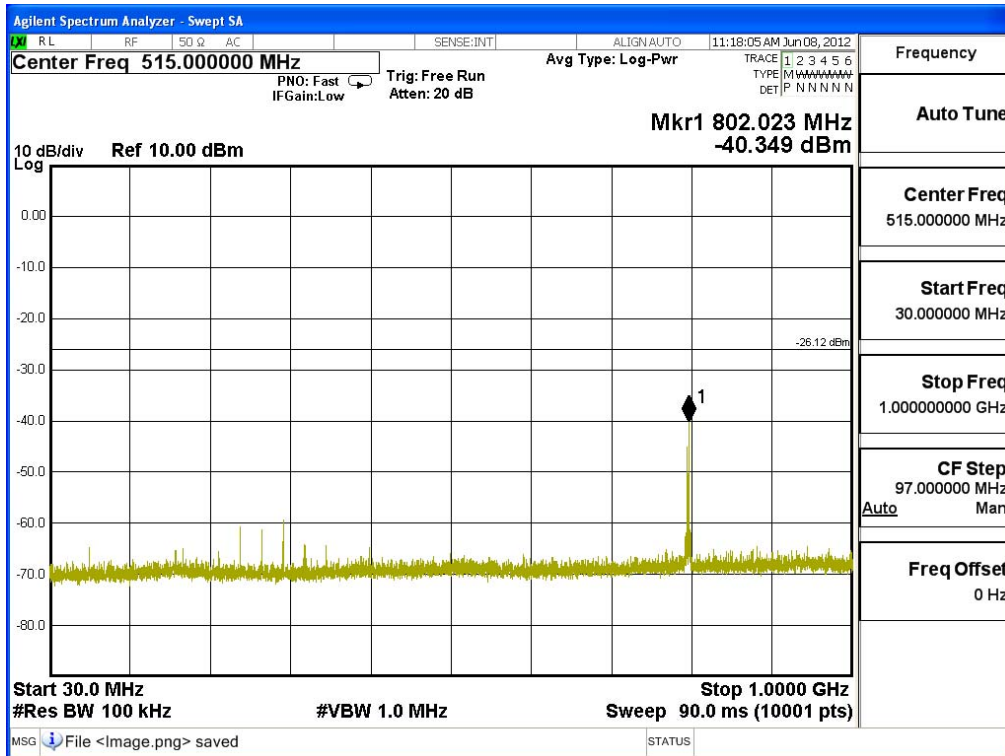

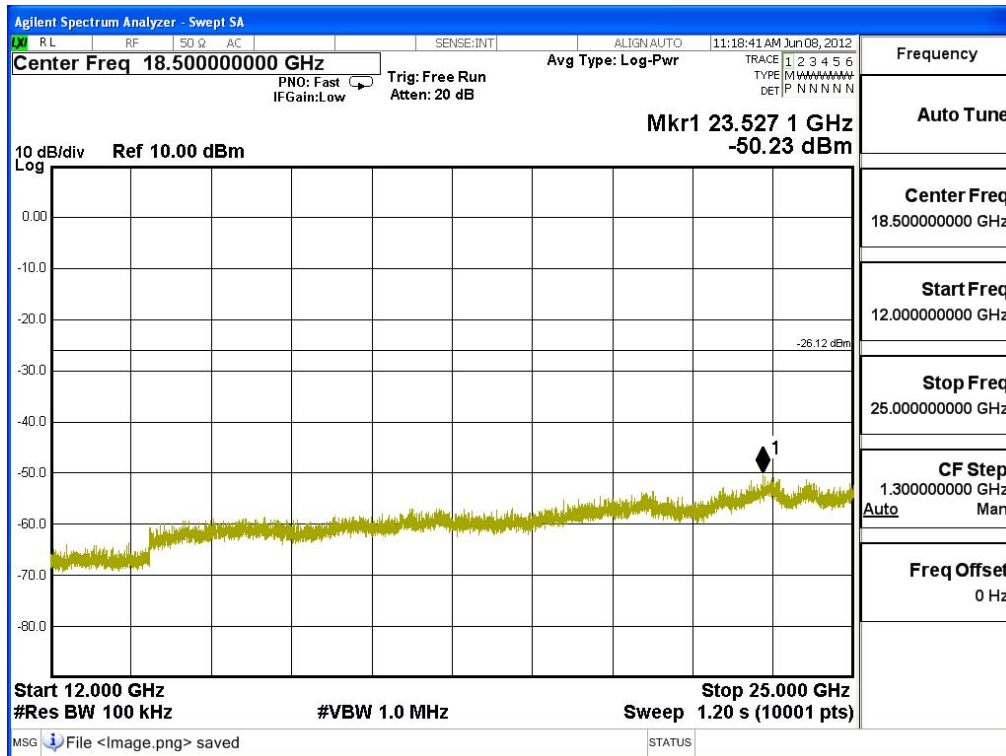
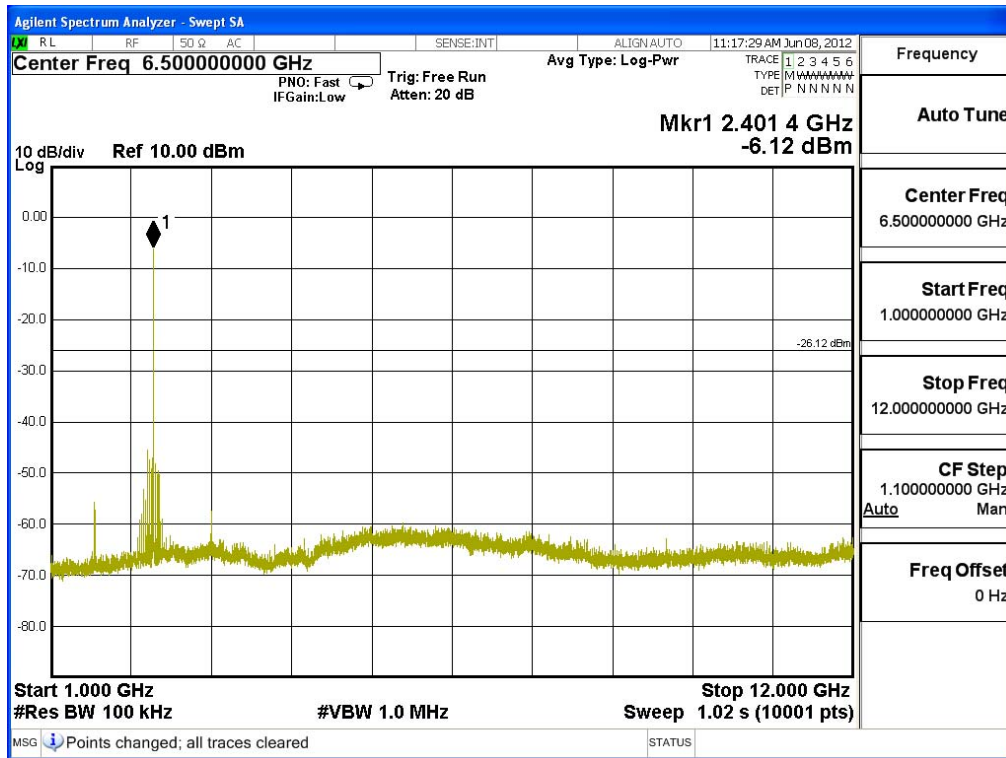

Product : Printer
 Test Item : RF Antenna Conducted Test
 Test Site : No.3 OATS
 Test Mode : Mode 1: Transmit - 1Mbps (GFSK) +Adapter#2

Figure Channel 39:

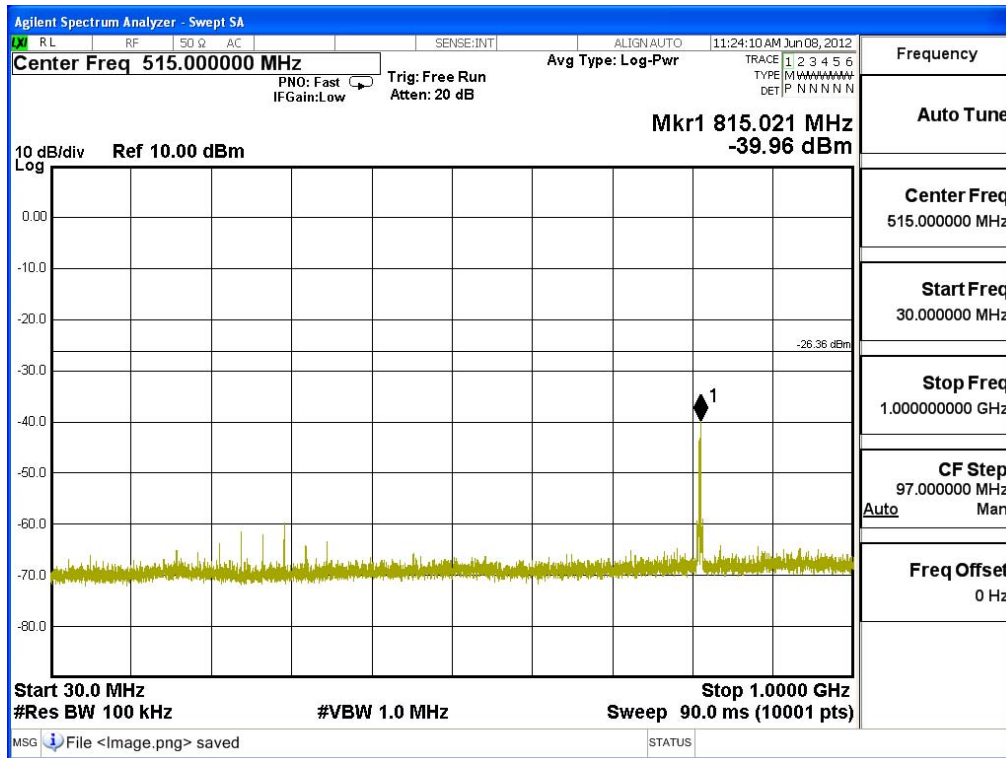

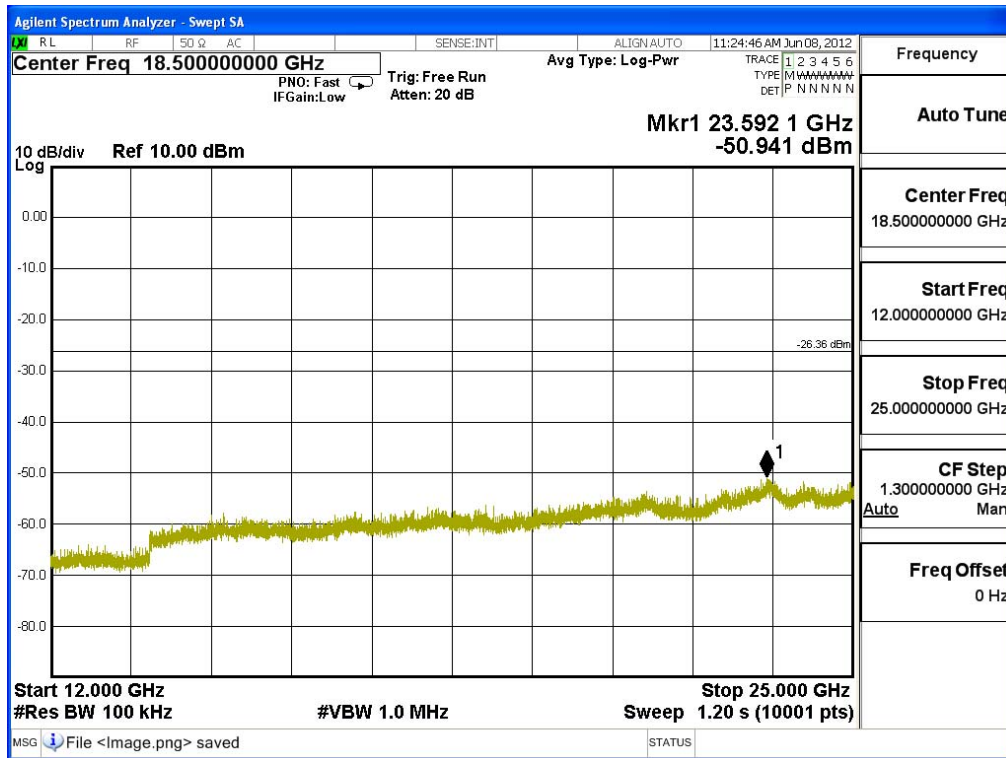
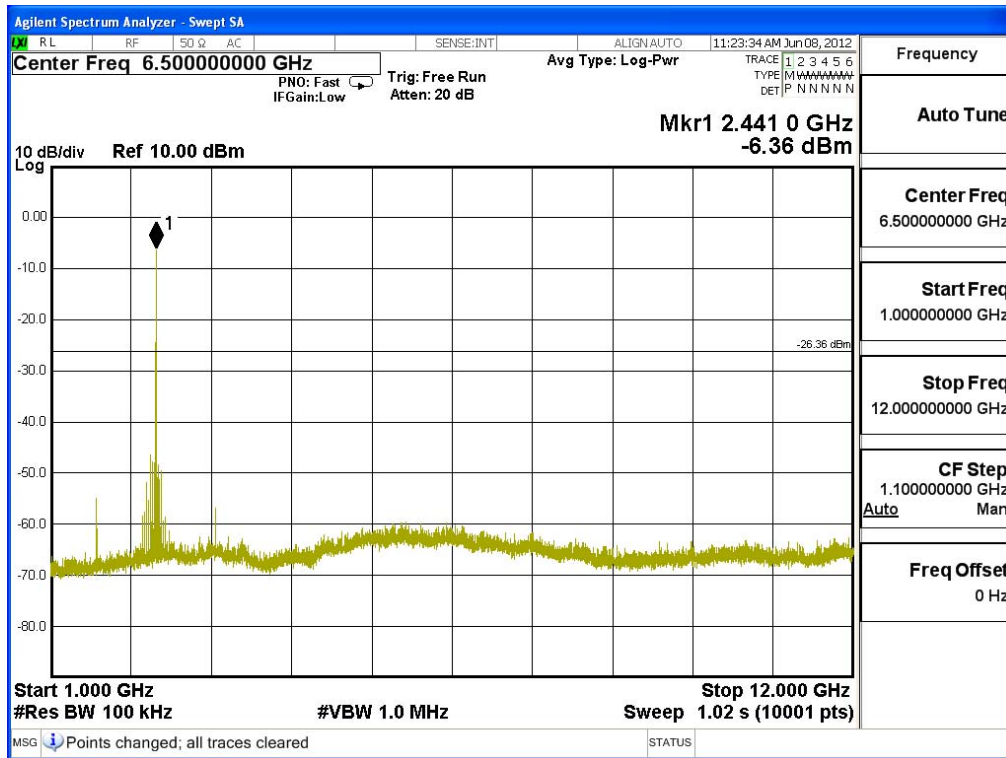

Product : Printer
 Test Item : RF Antenna Conducted Test
 Test Site : No.3 OATS
 Test Mode : Mode 1: Transmit - 1Mbps (GFSK) +Adapter#2

Figure Channel 78:

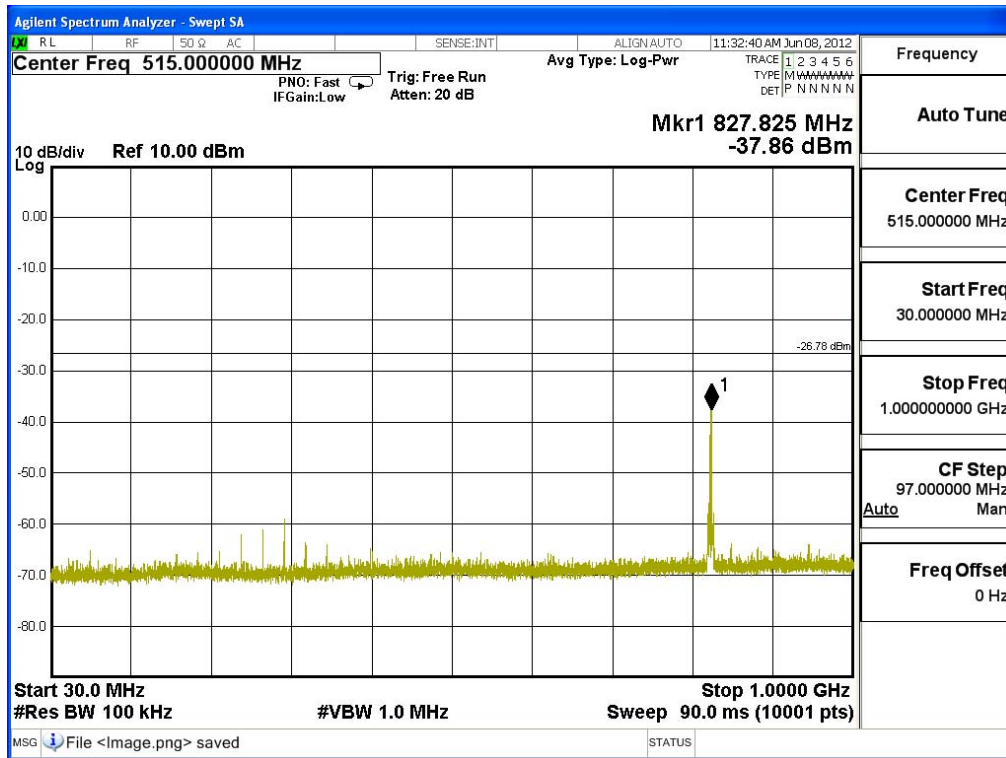

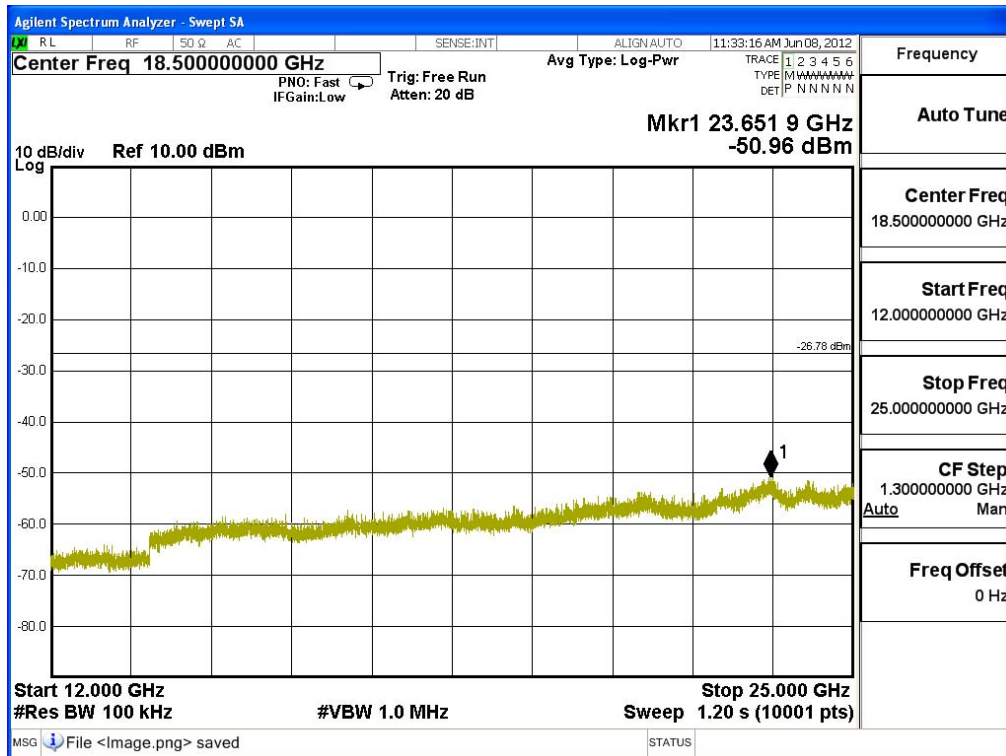
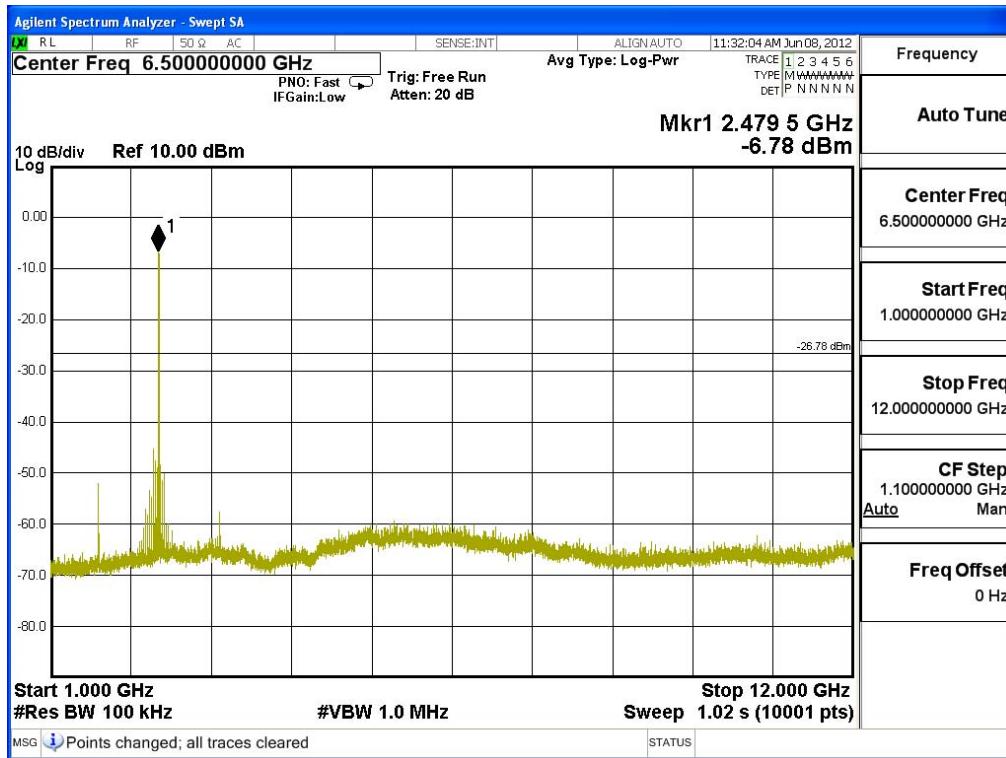

Product : Printer
 Test Item : RF Antenna Conducted Test
 Test Site : No.3 OATS
 Test Mode : Mode 2: Transmit - 3Mbps (8DPSK) +Adapter#2

Figure Channel 00:

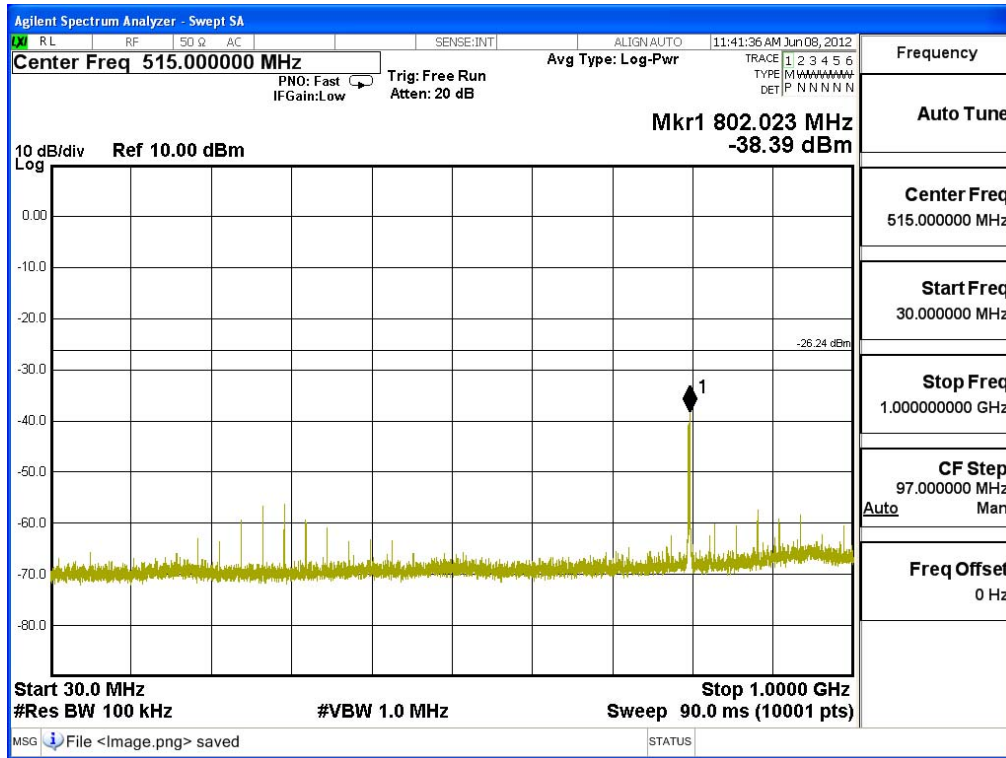

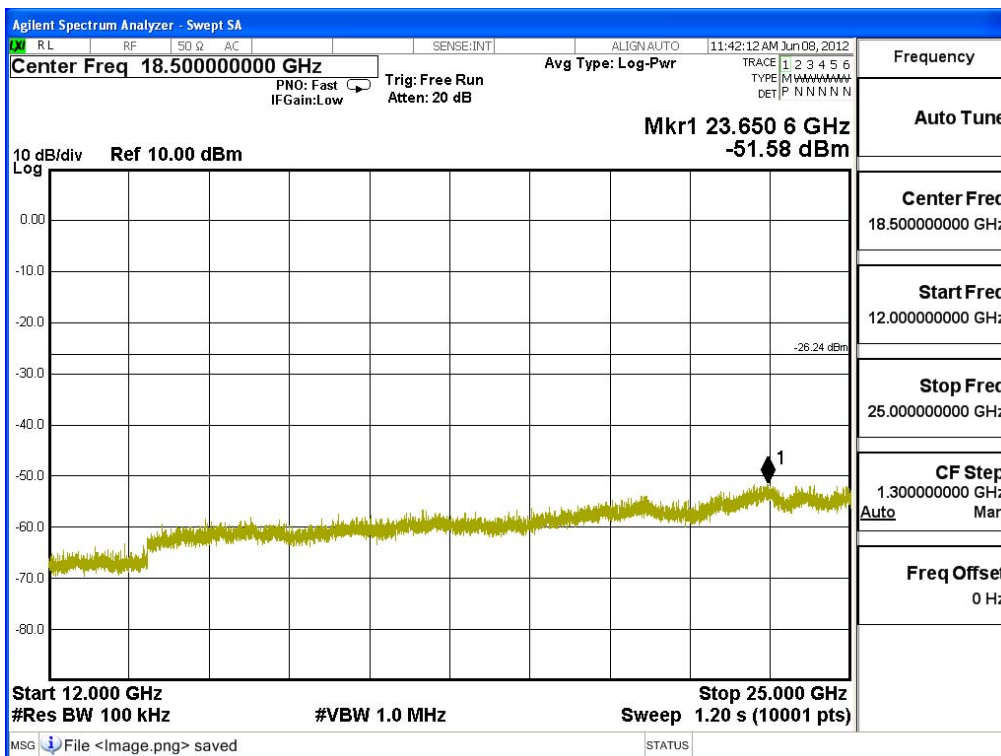
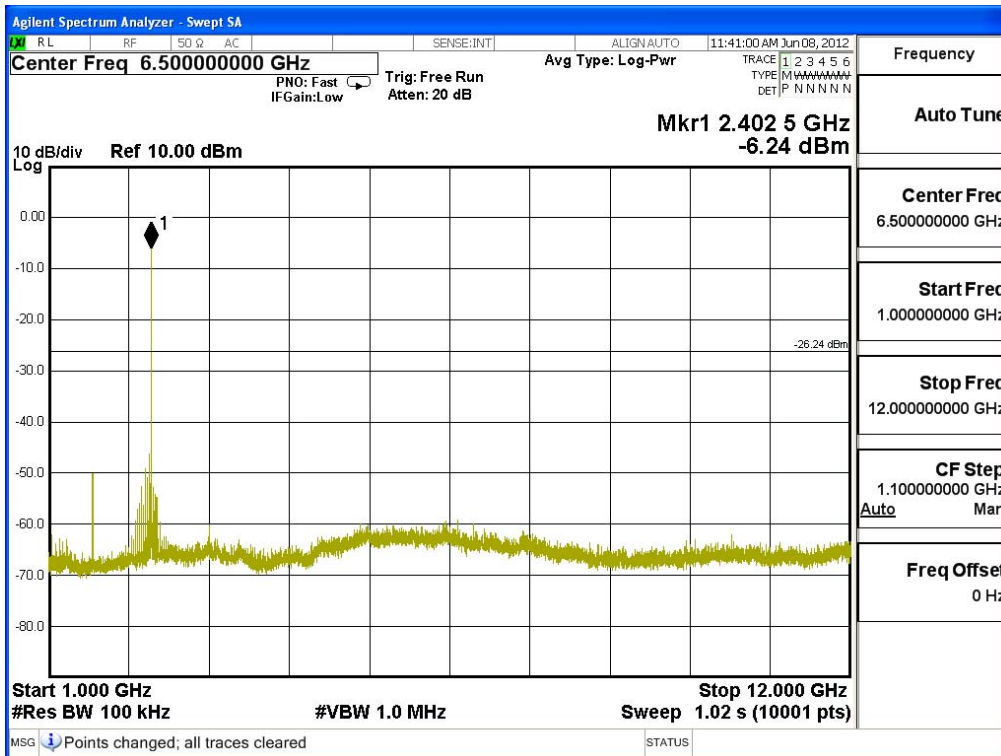

Product : Printer
 Test Item : RF Antenna Conducted Test
 Test Site : No.3 OATS
 Test Mode : Mode 2: Transmit - 3Mbps (8DPSK) +Adapter#2

Figure Channel 39:

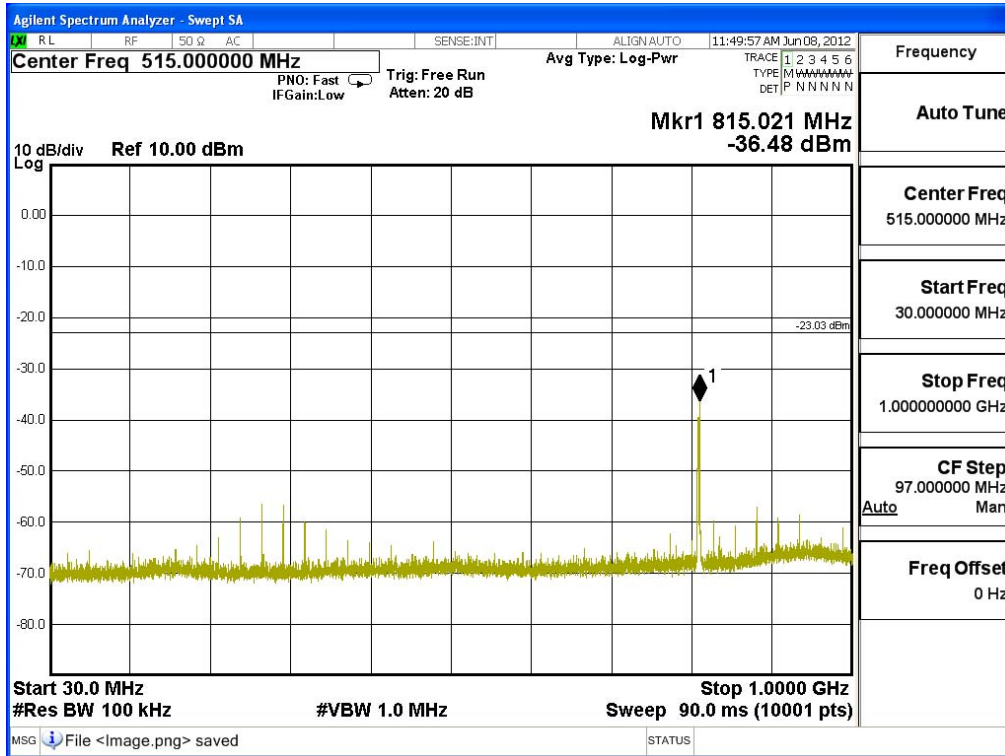

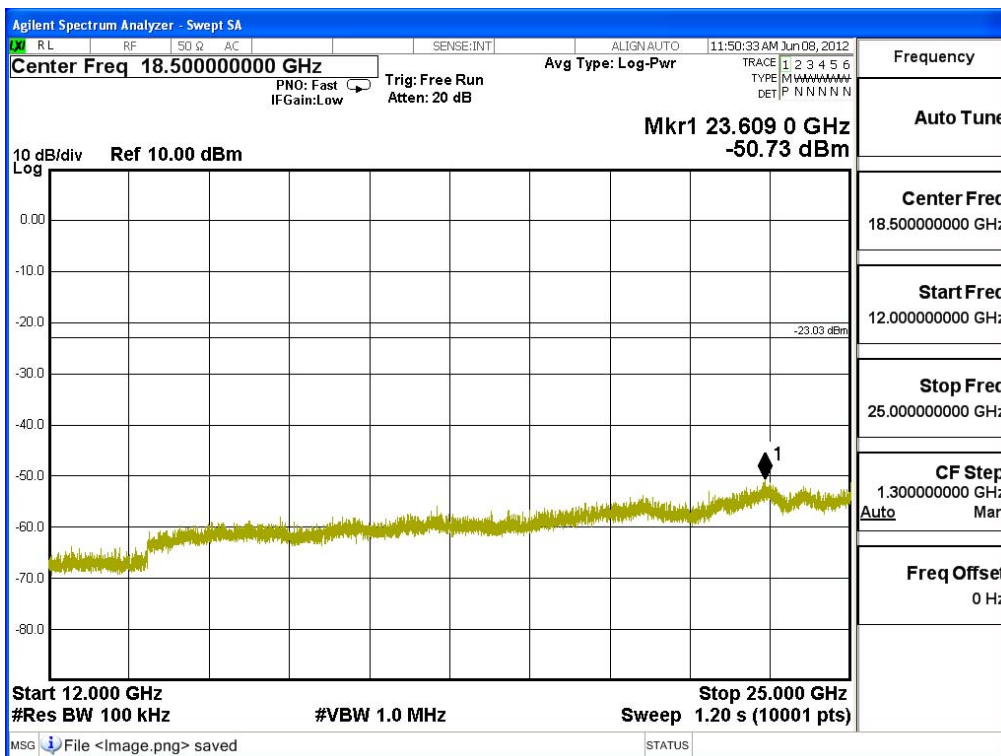
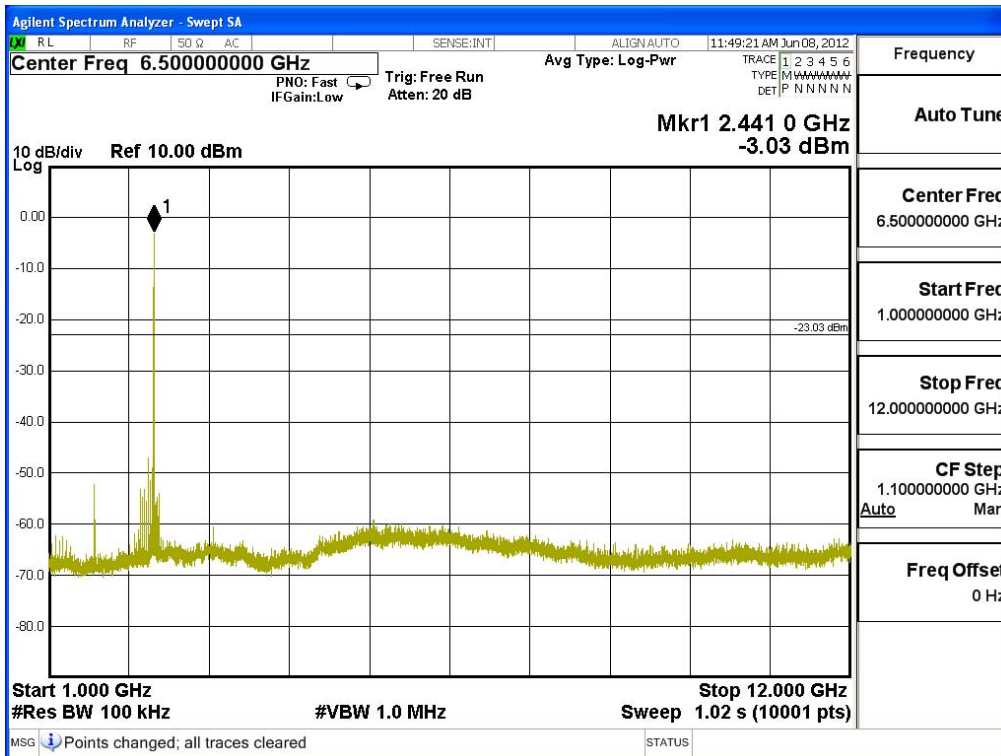

Product : Printer
 Test Item : RF Antenna Conducted Test
 Test Site : No.3 OATS
 Test Mode : Mode 2: Transmit - 3Mbps (8DPSK) +Adapter#2

Figure Channel 78:

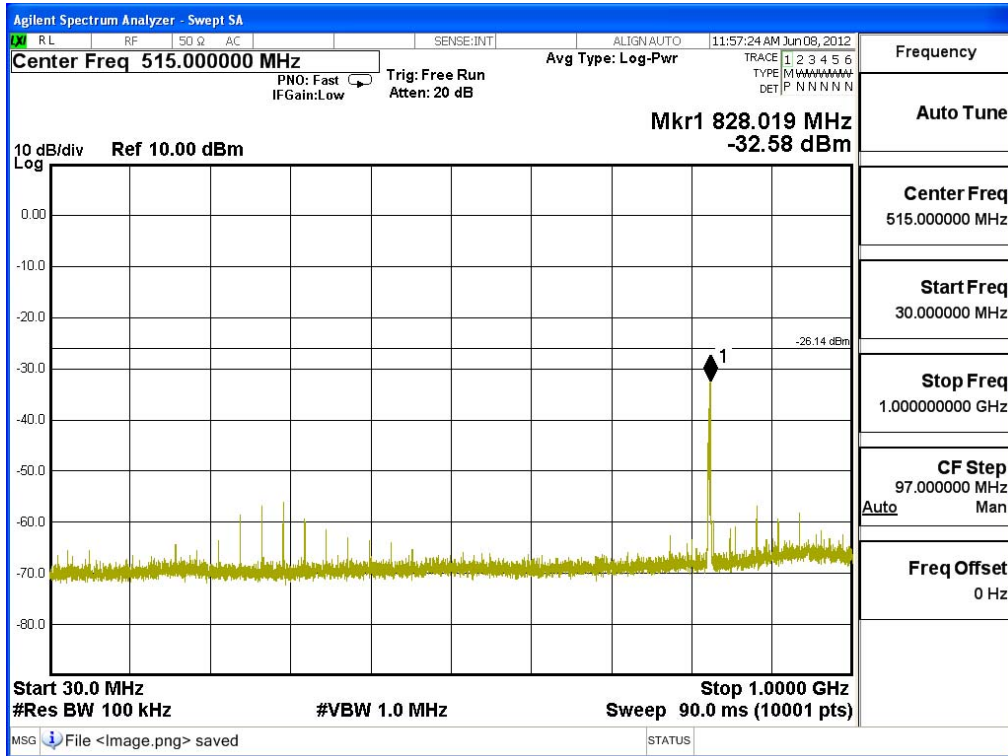

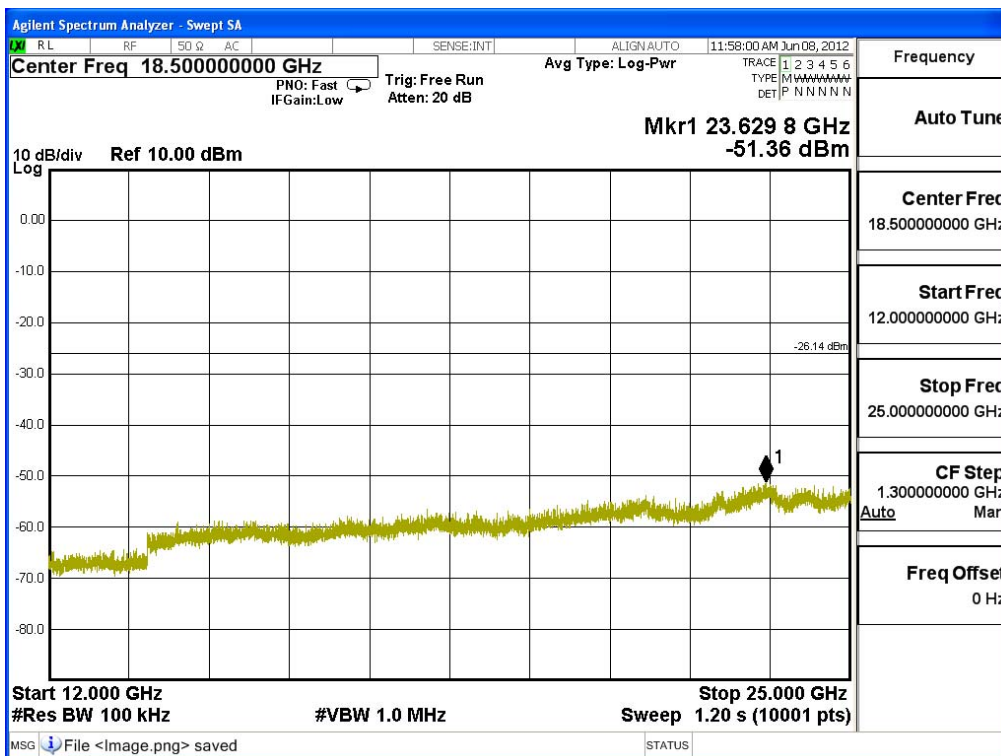
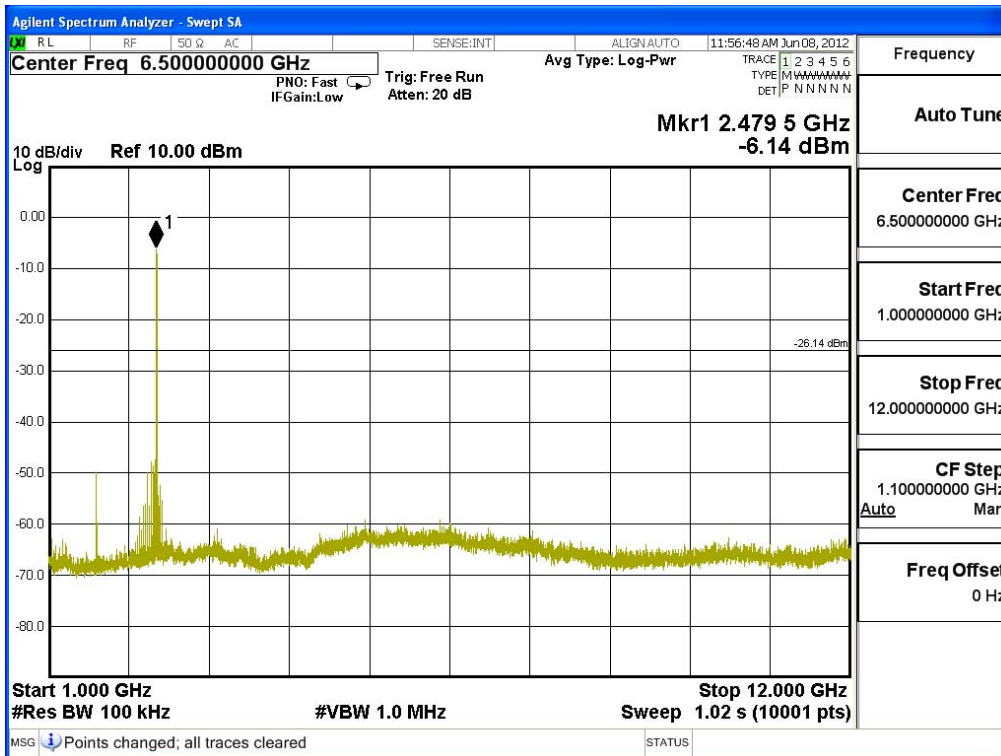

6. Band Edge

6.1. Test Equipment

RF Conducted Measurement

The following test equipments are used during the band edge tests:

	Equipment	Manufacturer	Model No./Serial No.	Last Cal.
	Spectrum Analyzer	R&S	FSP40 / 100170	Jun, 2012
	Spectrum Analyzer	Agilent	E4407B / US39440758	Jun, 2012
X	Spectrum Analyzer	Agilent	N9010A / MY48030495	Apr., 2012

RF Radiated Measurement:

The following test equipments are used during the band edge tests:

Test Site		Equipment	Manufacturer	Model No./Serial No.	Last Cal.
☒ Site # 3		Bilog Antenna	Schaffner Chase	CBL6112B/2673	Sep., 2011
	X	Horn Antenna	Schwarzbeck	BBHA9120D/D305	Sep., 2011
		Horn Antenna	Schwarzbeck	BBHA9170/208	Jul., 2012
	X	Pre-Amplifier	Agilent	8447D/2944A09549	Sep., 2011
	X	Spectrum Analyzer	Agilent	E4407B / US39440758	May, 2012
		Test Receiver	R & S	ESCS 30/ 825442/018	Sep., 2011
	X	Coaxial Cable	Quietek	QTK-CABLE/ CAB5	Feb., 2012
	X	Controller	Quietek	QTK-CONTROLLER/ CTRL3	N/A
	X	Coaxial Switch	Anritsu	MP59B/6200265729	N/A

- Note:
1. All equipments are calibrated every one year.
 2. The test instruments marked by "X" are used to measure the final test results.

6.2. Test Setup

RF Conducted Measurement

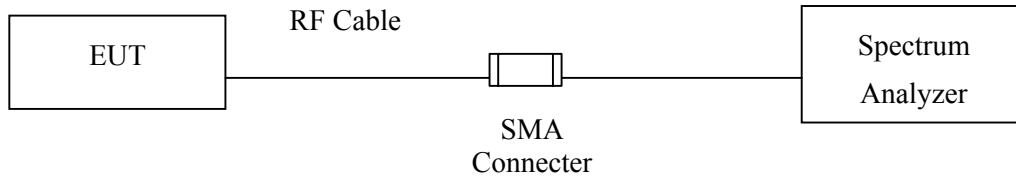

RF Radiated Measurement:

Above 1GHz

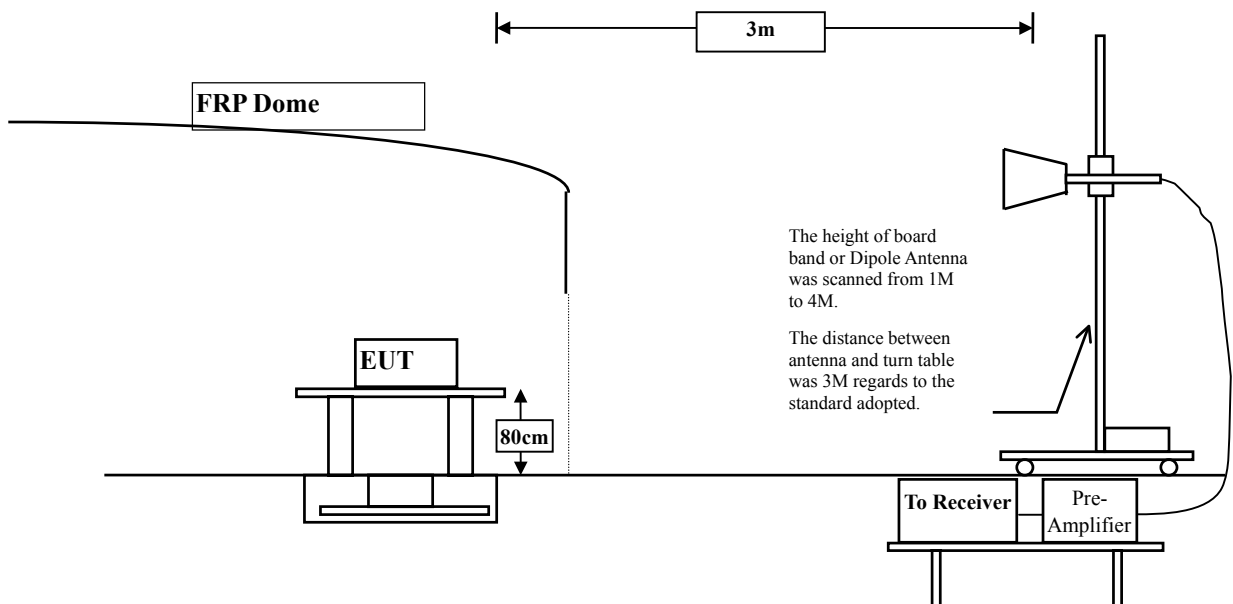

6.3. Limit

In any 100 kHz bandwidth outside the frequency band in which the spread spectrum intentional radiator is operating, the radio frequency power that is produced by the intentional radiator shall be at least 20 dB below that in the 100 kHz bandwidth within the band that contains the highest level of the desired power, based on either an RF conducted or a radiated measurement. Attenuation below the general limits specified in Section 15.209(a) is not required. In addition, radiated emissions which fall in the restricted bands, as defined in Section 15.205(a), must also comply with the radiated emission limits specified in Section 15.209(a) (see Section 15.205(c)).

6.4. Test Procedure

The EUT and its simulators are placed on a turn table which is 0.8 meter above ground. The turn table can rotate 360 degrees to determine the position of the maximum emission level. The EUT was positioned such that the distance from antenna to the EUT was 3 meters.

The antenna can move up and down between 1 meter and 4 meters to find out the maximum emission level.

Both horizontal and vertical polarization of the antenna are set on measurement. In order to find the maximum emission, all of the interface cables must be manipulated according to ANSI C63.4:2003 on radiated measurement.

The bandwidth below 1GHz setting on the field strength meter is 120 kHz, above 1GHz are 1 MHz. The EUT was setup to ANSI C63.4, 2003; tested to FHSS test procedure of FCC Public Notice DA 00-705 for compliance to FCC 47CFR 15.247 requirements.

6.5. Uncertainty

± 3.9 dB above 1GHz

± 3.8 dB below 1GHz

6.6. Test Result of Band Edge

Product : Printer
 Test Item : Band Edge
 Test Site : No.3 OATS
 Test Mode : Mode 1: Transmit - 1Mbps (GFSK) +Adapter#2

Fundamental Filed Strength

Antenna Pole	Frequency [MHz]	Correction Factor [dB/m]	Reading Level [dBuV]	Emission Level [dBuV/m]	Detector
Horizontal	2402	31.573	48.95	80.524	Peak
Horizontal	2402	31.573	39.96	71.534	Average
Vertical	2402	30.917	52.86	83.777	Peak
Vertical	2402	30.917	43.36	74.277	Average

Note: 1:Spectrum Analyzer setting:

Peak detector: RBW=1MHz, VBW=1MHz

Average detector: RBW=1MHz, VBW=10Hz

Band Edge Test Data

Antenna Pole	Test Frequency (MHz)	Fundamental (dBuV/m)	Δ (dB)	Band Edge Field Strength (dBuV/m)	Limit (dBuV/m)	Detector
Horizontal	2349.6	80.524	39.81	40.714	74.000	Peak
Horizontal	2350	71.534	34.31	37.224	54.000	Average
Vertical	2349.6	83.777	39.81	43.967	74.000	Peak
Vertical	2350	74.277	34.31	39.967	54.000	Average

Note:

The Band Edge Field Strength was calculated using the Fundamental and Conducted Band Edge measurements per the Marker-Delta Method with the following formula:

Band Edge field Strength = F - Δ

F = Fundamental field Strength (Peak or Average)

Δ = Conducted Band Edge Delta (Peak or Average)

Peak Detector of conducted Band Edge Delta

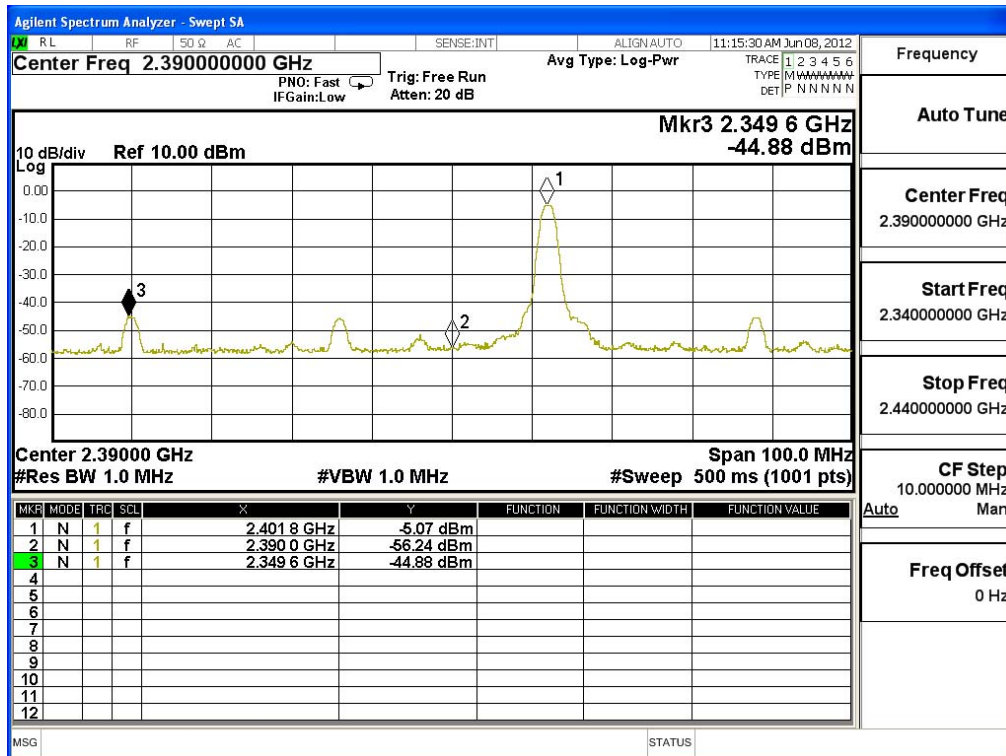

Average Detector of conducted Band Edge Delta

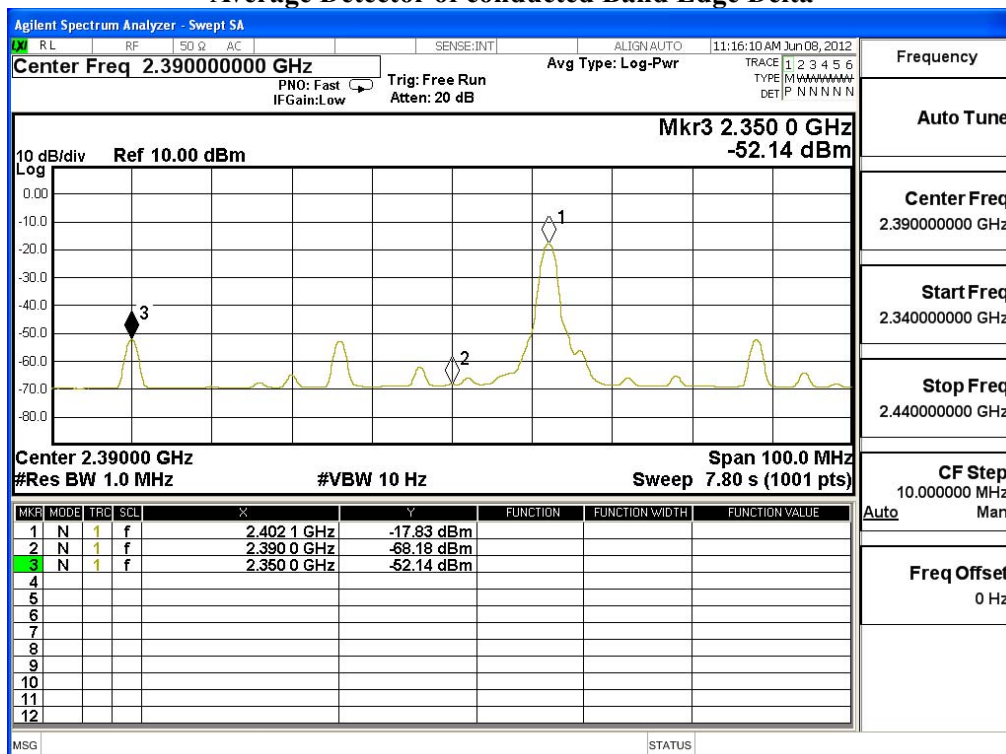

Product : Printer
 Test Item : Band Edge
 Test Site : No.3 OATS
 Test Mode : Mode 1: Transmit - 1Mbps (GFSK) +Adapter#2

Fundamental Filed Strength

Antenna Pole	Frequency [MHz]	Correction Factor [dB/m]	Reading Level [dBuV]	Emission Level [dB(uV/m)]	Detector
Horizontal	2480	32.155	53.07	85.226	Peak
Horizontal	2480	32.155	43.51	75.666	Average
Vertical	2480	31.412	54.61	86.022	Peak
Vertical	2480	31.412	44.72	76.132	Average

Note: 1:Spectrum Analyzer setting:

Peak detector: RBW=1MHz, VBW=1MHz

Average detector: RBW=1MHz, VBW=10Hz

Band Edge Test Data

Antenna Pole	Test Frequency (MHz)	Fundamental (dBuV/m)	Δ (dB)	Band Edge Field Strength (dBuV/m)	Limit (dBuV/m)	Detector
Horizontal	2483.5	85.226	41.63	43.596	74.000	Peak
Horizontal	2483.5	75.666	40.66	35.006	54.000	Average
Vertical	2483.5	86.022	41.63	44.392	74.000	Peak
Vertical	2483.5	76.132	40.66	35.472	54.000	Average

Note:

The Band Edge Field Strength was calculated using the Fundamental and Conducted Band Edge measurements per the Marker-Delta Method with the following formula:

Band Edge field Strength = F - Δ

F = Fundamental field Strength (Peak or Average)

Δ = Conducted Band Edge Delta (Peak or Average)

Peak Detector of conducted Band Edge Delta

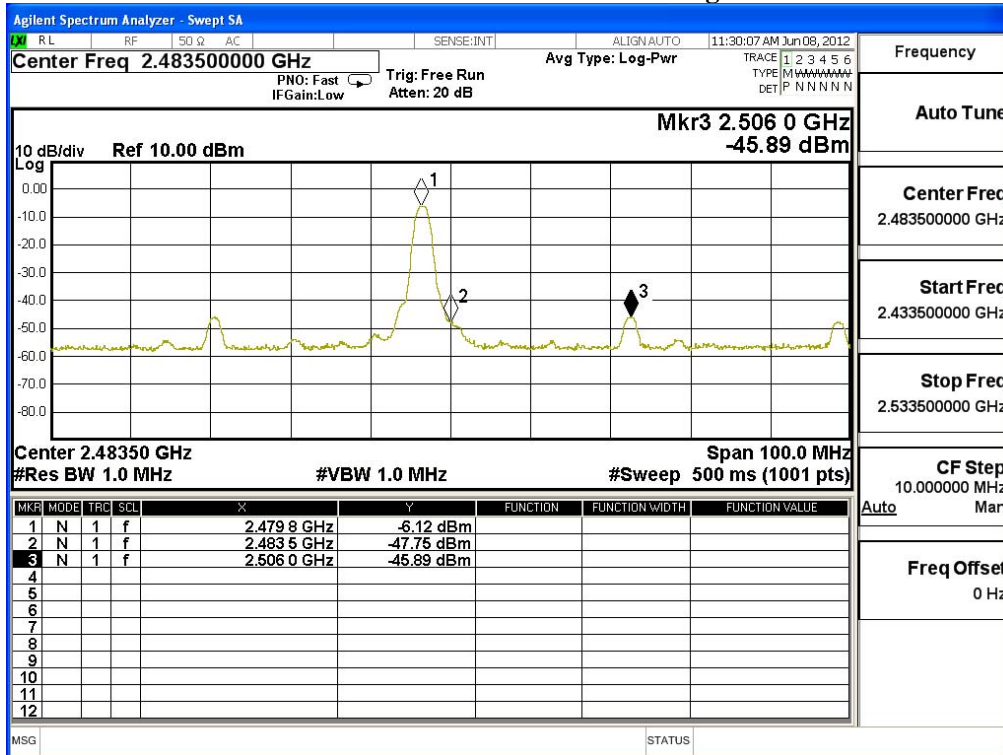

Average Detector of conducted Band Edge Delta

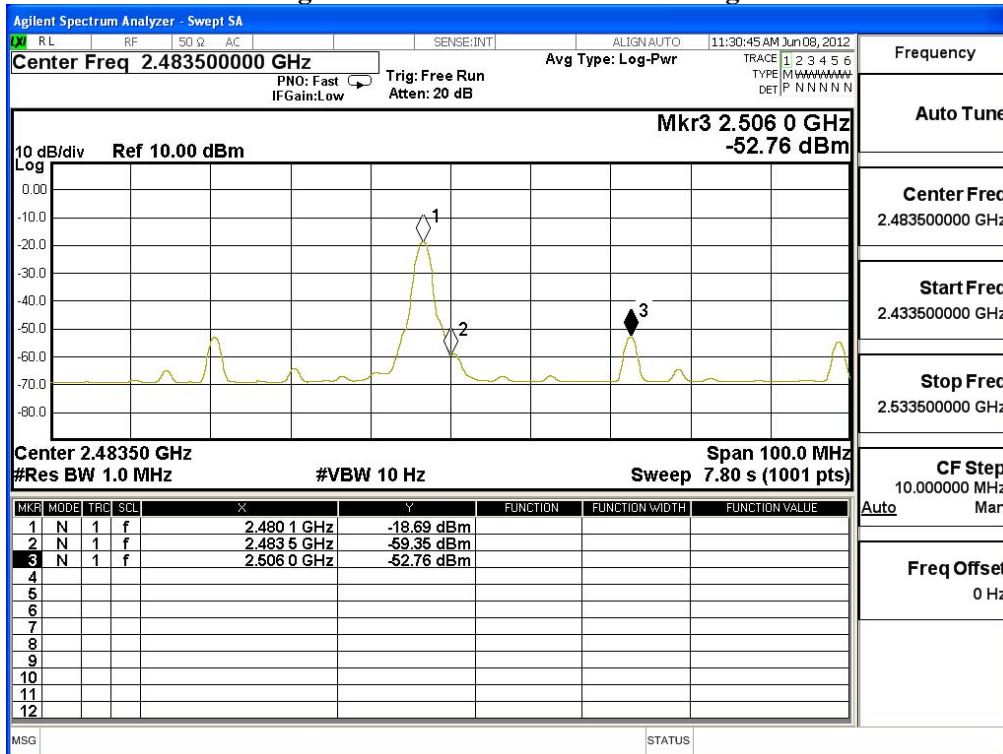

Product : Printer
 Test Item : Band Edge
 Test Site : No.3 OATS
 Test Mode : Mode 2: Transmit - 3Mbps (8DPSK) +Adapter#2

Fundamental Filed Strength

Antenna Pole	Frequency [MHz]	Correction Factor [dB/m]	Reading Level [dBuV]	Emission Level [dBuV/m]	Detector
Horizontal	2402	31.573	49.03	80.604	Peak
Horizontal	2402	31.573	37.92	69.494	Average
Vertical	2402	30.917	50.86	81.777	Peak
Vertical	2402	30.917	39.45	70.367	Average

Note: 1:Spectrum Analyzer setting:

Peak detector: RBW=1MHz, VBW=1MHz

Average detector: RBW=1MHz, VBW=10Hz

Band Edge Test Data

Antenna Pole	Test Frequency (MHz)	Fundamental (dBuV/m)	Δ (dB)	Band Edge Field Strength (dBuV/m)	Limit (dBuV/m)	Detector
Horizontal	2375.8	80.604	41.74	38.864	74.000	Peak
Horizontal	2376	69.494	34.96	34.534	54.000	Average
Vertical	2375.8	81.777	41.74	40.037	74.000	Peak
Vertical	2376	70.367	34.96	35.407	54.000	Average

Note:

The Band Edge Field Strength was calculated using the Fundamental and Conducted Band Edge measurements per the Marker-Delta Method with the following formula:

Band Edge field Strength = F - Δ

F = Fundamental field Strength (Peak or Average)

Δ = Conducted Band Edge Delta (Peak or Average)

Peak Detector of conducted Band Edge Delta

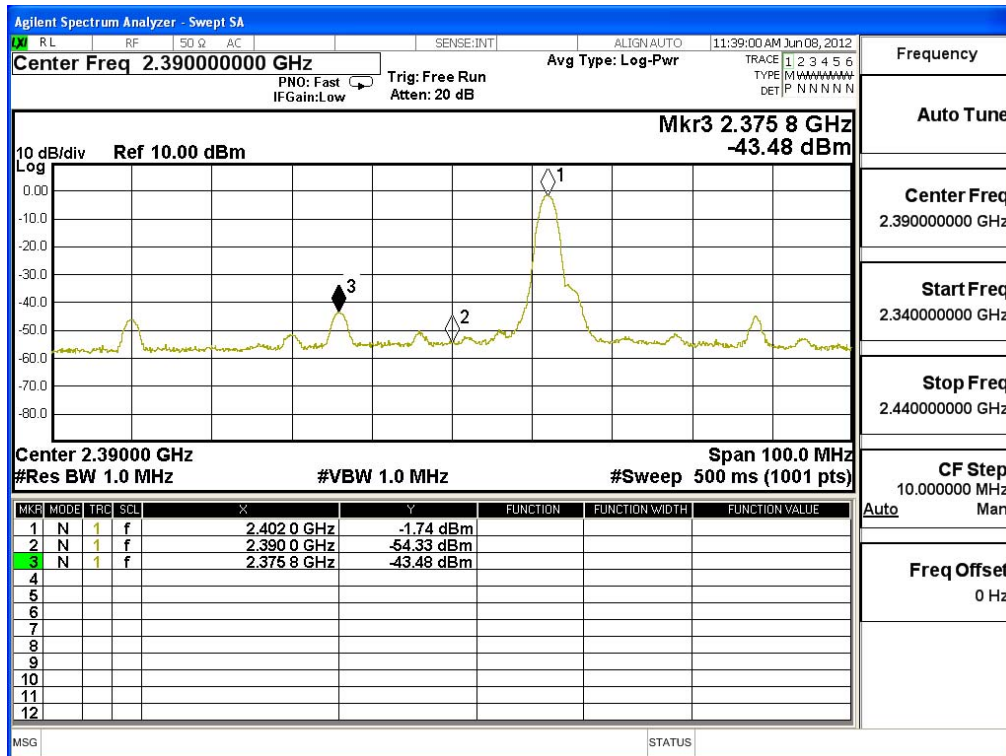

Average Detector of conducted Band Edge Delta

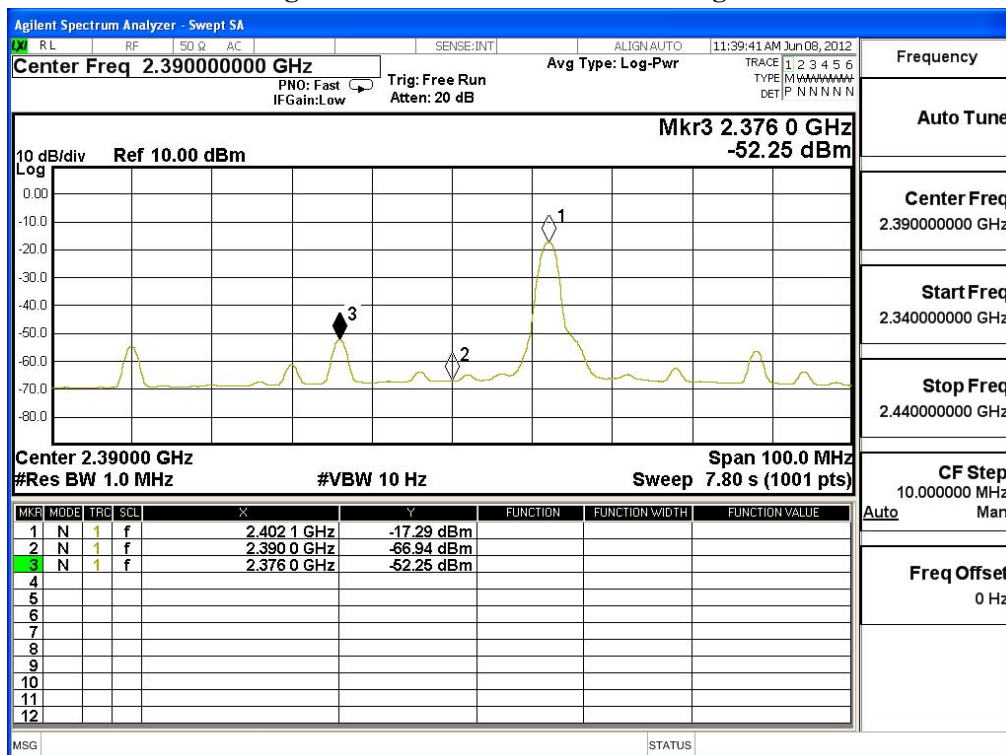

Product : Printer
 Test Item : Band Edge
 Test Site : No.3 OATS
 Test Mode : Mode 2: Transmit - 3Mbps (8DPSK) +Adapter#2

Fundamental Filed Strength

Antenna Pole	Frequency [MHz]	Correction Factor [dB/m]	Reading Level [dBuV]	Emission Level [dB(uV/m)]	Detector
Horizontal	2480	32.155	50.9	83.056	Peak
Horizontal	2480	32.155	39.47	71.626	Average
Vertical	2480	31.412	52.61	84.022	Peak
Vertical	2480	31.412	40.62	72.032	Average

Note: 1:Spectrum Analyzer setting:

Peak detector: RBW=1MHz, VBW=1MHz

Average detector: RBW=1MHz, VBW=10Hz

Band Edge Test Data

Antenna Pole	Test Frequency (MHz)	Fundamental (dBuV/m)	Δ (dB)	Band Edge Field Strength (dBuV/m)	Limit (dBuV/m)	Detector
Horizontal	2483.5	83.056	34.26	48.796	74.000	Peak
Horizontal	2483.5	71.626	35.39	36.236	54.000	Average
Vertical	2483.5	84.022	34.26	49.762	74.000	Peak
Vertical	2483.5	72.032	35.39	36.642	54.000	Average

Note:

The Band Edge Field Strength was calculated using the Fundamental and Conducted Band Edge measurements per the Marker-Delta Method with the following formula:

Band Edge field Strength = F - Δ

F = Fundamental field Strength (Peak or Average)

Δ = Conducted Band Edge Delta (Peak or Average)

Peak Detector of conducted Band Edge Delta

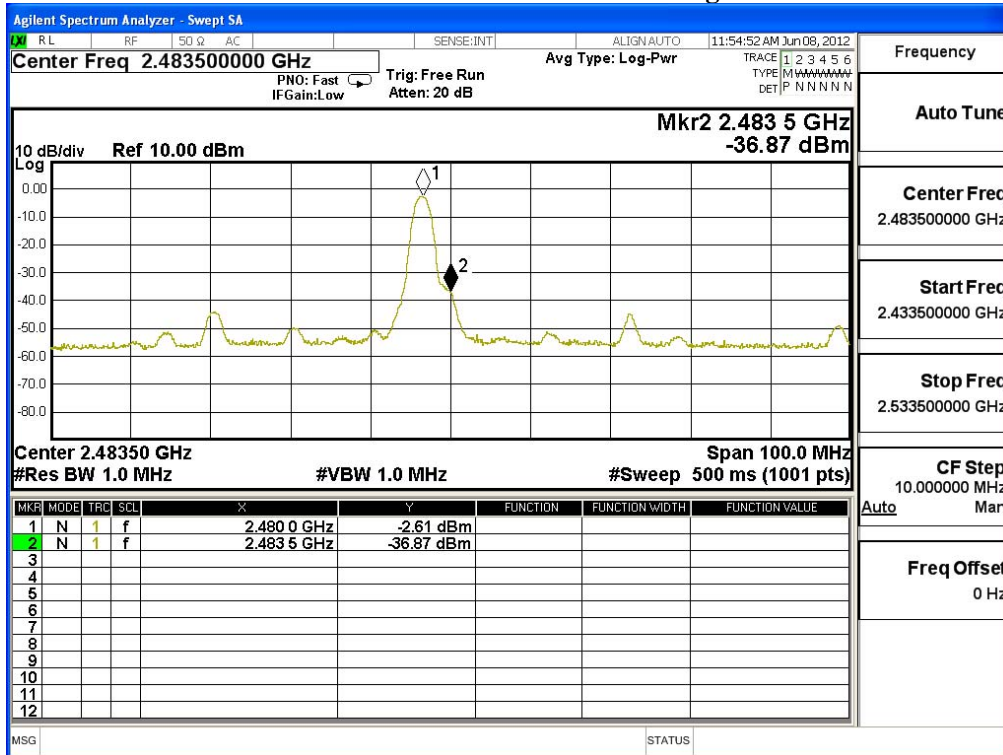

Average Detector of conducted Band Edge Delta

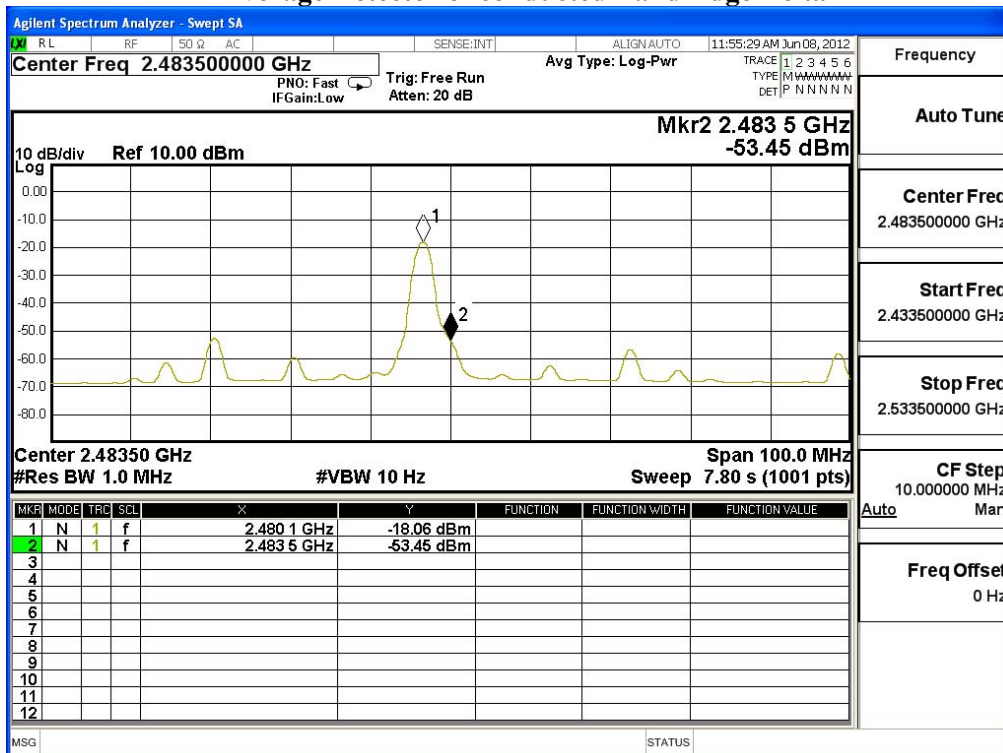

7. Channel Number

7.1. Test Equipment

	Equipment	Manufacturer	Model No./Serial No.	Last Cal.
	Spectrum Analyzer	R&S	FSP40 / 100170	Jun, 2012
	Spectrum Analyzer	Agilent	E4407B / US39440758	Jun, 2012
X	Spectrum Analyzer	Agilent	N9010A / MY48030495	Apr., 2012

Note: 1. All equipments are calibrated every one year.
 2. The test instruments marked by “X” are used to measure the final test results.

7.2. Test Setup

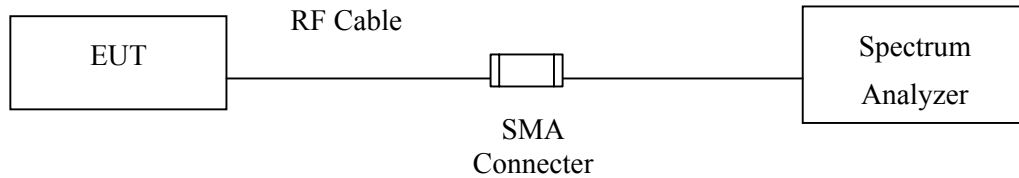

7.3. Limit

Frequency hopping systems operating in the 2400-2483.5 MHz bands shall use at least 75 hopping frequencies.

7.4. Test Procedure

The EUT was setup to ANSI C63.4, 2003; tested to FHSS test procedure of FCC Public Notice DA 00-705 for compliance to FCC 47CFR 15.247 requirements.

7.5. Uncertainty

N/A

7.6. Test Result of Channel Number

Product : Printer
 Test Item : Channel Number
 Test Site : No.3 OATS
 Test Mode : Mode 1: Transmit - 1Mbps (GFSK) +Adapter#2

Frequency Range (MHz)	Measurement (Hopping Channel)	Required Limit (Hopping Channel)	Result
2402 ~ 2480	79	>75	Pass

2402-2421MHz

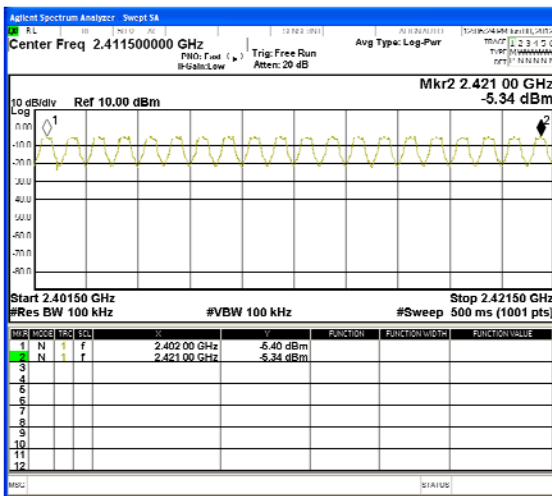

2422-2441MHz

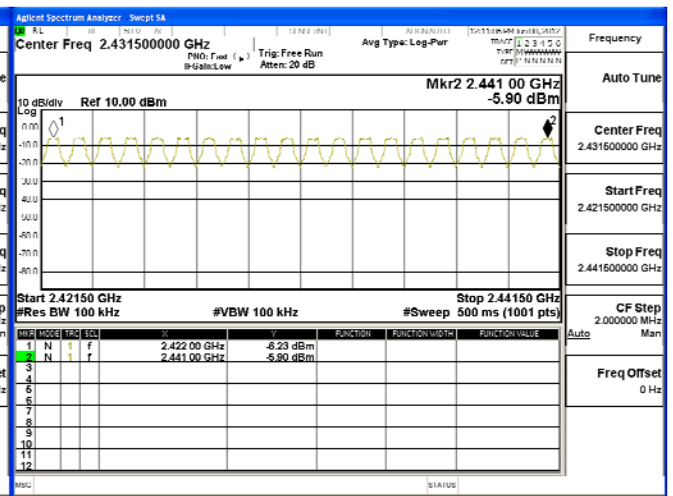

2442-2461MHz

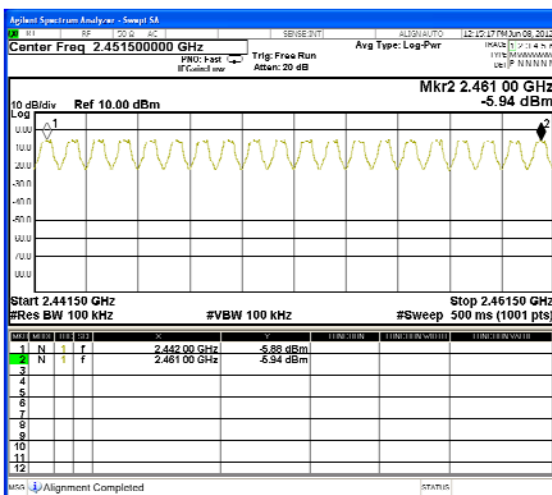

2462-2480MHz

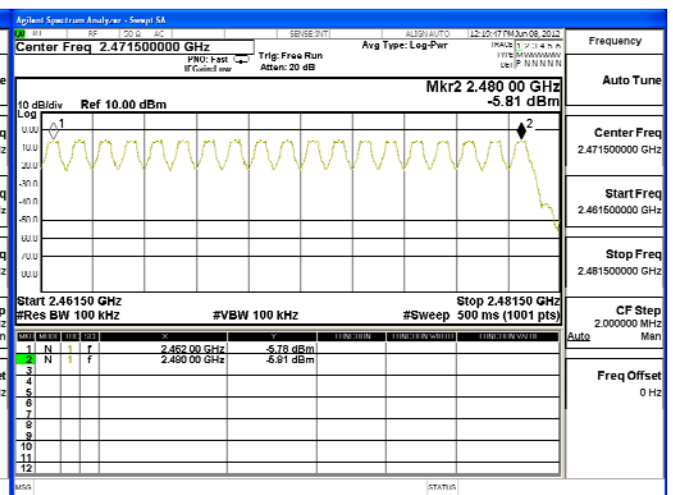

Product : Printer
 Test Item : Channel Number
 Test Site : No.3 OATS
 Test Mode : Mode 2: Transmit - 3Mbps (8DPSK) +Adapter#2

Frequency Range (MHz)	Measurement (Hopping Channel)	Required Limit (Hopping Channel)	Result
2402 ~ 2480	79	>75	Pass

2402-2421MHz

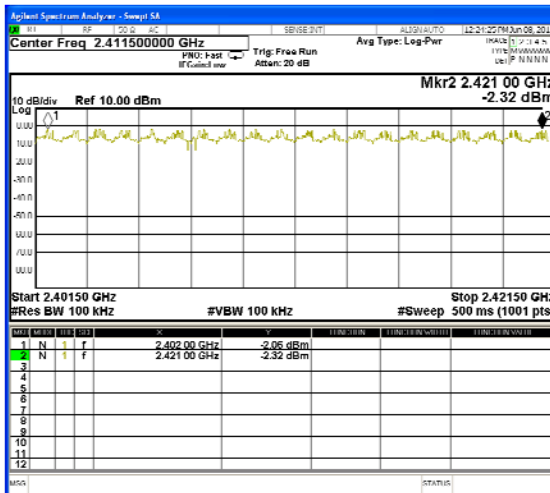

2422-2441MHz

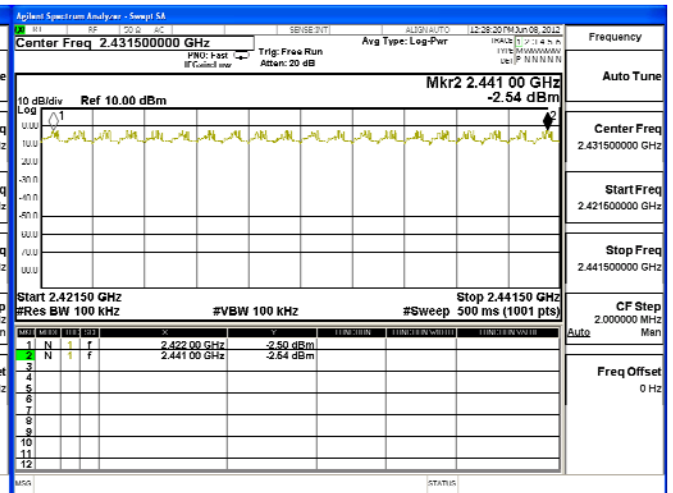

2442-2461MHz

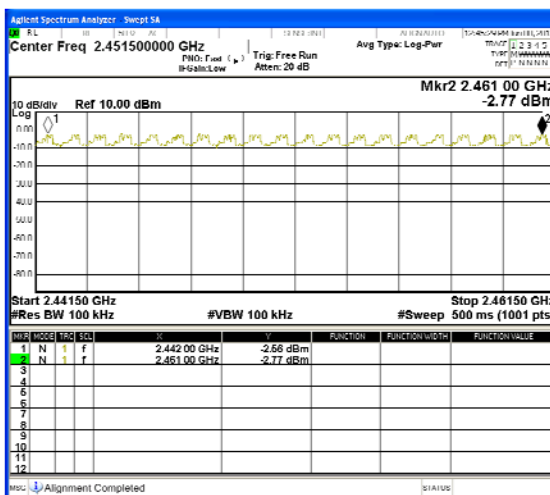

2462-2480MHz

