



Test Report

Product Name : Control Point 1000
Model No. : CP-1000ez
FCC ID. : VTQCP1KEZ0711

Applicant : Alpha Telecom, Inc. U.S.A.

Address : 1362 Borregas Ave., Sunnyvale, CA94089, U.S.A.

Date of Receipt : 2007/10/18
Issued Date : 2007/11/21
Report No. : 07A260R-RFUSP07V01

The test results relate only to the samples tested.

The test report shall not be reproduced except in full without the written approval of QuieTek Corporation.

Test Report Certification

Issued Date : 2007/11/21

Report No. : 07A260R-RFUSP07V01



Product Name : Control Point 1000
 Applicant : Alpha Telecom, Inc. U.S.A.
 Address : 1362 Borregas Ave., Sunnyvale, CA94089, U.S.A.
 Manufacturer : Alpha Telecom, Inc. U.S.A.
 Model No. : CP-1000ez
 FCC ID. : VTQCP1KEZ0711
 Rated Voltage : AC 120 V / 60 Hz
 EUT Voltage : AC90~240V / 50~60Hz
 Trade Name : ALPHA TELECOM
 Applicable Standard : FCC CFR Title 47 Part 15 Subpart C Section 15.249: 2006
 Test Result : Complied

The test results relate only to the samples tested.

The test report shall not be reproduced except in full without the written approval of Quietek Corporation.

Documented By : Carol Tsai
 (Carol Tsai / Adm. Specialist)
 Reviewed By : Sheena Huang
 (Sheena Huang / Assistant Engineer)
 Approved By : Roy Wang
 (Roy Wang / Manager)

TABLE OF CONTENTS

Description	Page
1. General Information	4
1.1. EUT Description	4
1.2. Operational Description	5
1.3. Test Mode	6
1.4. Tested System Details	7
1.5. Configuration of tested System	8
1.6. EUT Exercise Software	8
1.7. Test Facility	9
2. Conducted Emission	10
2.1. Test Equipment	10
2.2. Test Setup	10
2.3. Limits	11
2.4. Test Procedure	11
2.5. Test Specification	11
2.6. Uncertainty	11
2.7. Test Result	12
2.8. Test Photo	20
3. Radiated Emission	22
3.1. Test Equipment	22
3.2. Test Setup	22
3.3. Limits	23
3.4. Test Procedure	24
3.5. Test Specification	24
3.6. Uncertainty	24
3.7. Test Result	25
3.8. Test Photo	33
4. Band Edge	36
4.1. Test Equipment	36
4.2. Test Setup	37
4.3. Limits	38
4.4. Test Procedure	38
4.5. Test Specification	38
4.6. Uncertainty	38
4.7. Test Result	39
Attachement	47
EUT Photograph	47

1. General Information

1.1. EUT Description

Product Name	Control Point 1000
Trade Name	ALPHA TELECOM
Model No.	CP-1000ez
Frequency Range	908.42MHz
Antenna Gain	-5.39 dBi
Channel Number	1
Type of Modulation	FSK
Channel Control	Single Channel
Antenna Type	Trace type
Power Adapter	OHE, SL-0306 I/P: 90~240 VAC / 50/60 Hz / 0.15~0.07A O/P: 12V / 0.4A Cable IN: Non-Shielded, 1.6m Cable Out Non-Shielded, 1.8m
Power Adapter	BILLION, 96PS-026 I/P: 100~240 VAC / 50/60 Hz O/P: 12V / 1.67A / 20W Max. Cable IN: Non-Shielded, 1.6m Cable Out Non-Shielded, 1.3m

Working Frequency of Each Channel	
Channel	Frequency
Channel 01	908.42 MHz

Note:

1. This device is a Control Point 1000 included a 908.42 MHz receiving function, and 908.42 MHz transmitting function.
2. These tests were conducted on a sample of the equipment for the purpose of demonstrating compliance with Part 15 Subpart C Paragraph 15.249.
3. Regards to the frequency band operation; the lowest , middle and highest frequency of channel were selected to perform the test, and then shown on this report.
4. This device is a composite device in accordance with Part 15 regulations. The function receiving was measured and made a test report that the report number is 07A260R-ITUSP01V02 under Declaration of Conformity.

1.3. Test Mode

QuieTek has verified the construction and function in typical operation. All the test modes were carried out with the EUT in normal operation, which was shown in this test report and defined as:

Pre-Test Mode	
EMI	Mode 1: Transmit (Adapter: OHE) Mode 2: Transmit (Adapter: BILLION)
Final Test Mode	
TX	Mode 1: Transmit (Adapter: OHE) Mode 2: Transmit (Adapter: BILLION)

Emission	Mode 1	Mode 2
Performed Item	Test	Test
Conducted Emission	Yes	Yes
Radiated Emission	Yes	Yes
Band Edge	Yes	No

1.4. Tested System Details

The types for all equipments, plus descriptions of all cables used in the tested system (including inserted cards) are:

	Product	Manufacturer	Model No.	Serial No.	FCC ID	Power Cord
1	Notebook PC	DELL	LATITUDE D400	N/A	DoC	Non-Shielded, 1.7m, one ferrite core bonded
2	USB 2.0 Flash Memory	Sony	USM2GJX	N/A	DoC	--
3	USB 2.0 Flash Memory	Sony	USM2GJX	N/A	DoC	--
4	USB 2.0 Flash Memory	Sony	USM2GJX	N/A	DoC	--
5	USB 2.0 Flash Memory	Sony	USM2GJX	N/A	DoC	--

1.5. Configuration of tested System

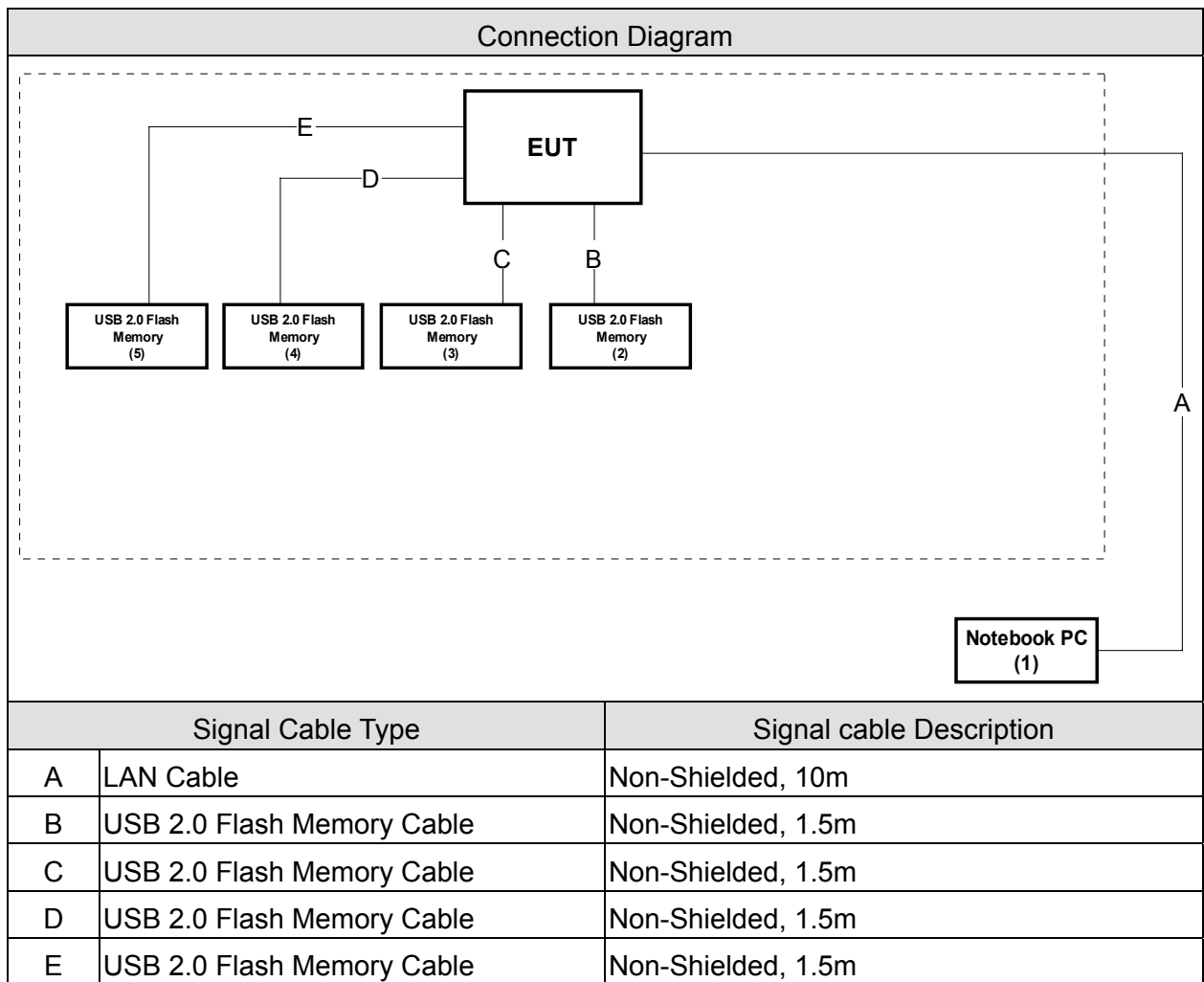

1.6. EUT Exercise Software

1	Setup the EUT and display as shown on 1.5.
2	Turn on the power of all equipment
3	The EUT (Rx) will continuously receive the radio signal.

1.7. Test Facility

Ambient conditions in the laboratory:

Items	Test Item	Required (IEC 68-1)	Actual
Temperature (°C)	FCC PART 15 C 15.207 Conducted Emission	15 - 35	25
Humidity (%RH)		25 - 75	50
Barometric pressure (mbar)		860 - 1060	950-1000
Temperature (°C)	FCC PART 15 C 15.249 Band Edge	15 - 35	25
Humidity (%RH)		25 - 75	65
Barometric pressure (mbar)		860 - 1060	950-1000
Temperature (°C)	FCC PART 15 C 15.209 Radiated Emission	15 - 35	25
Humidity (%RH)		25 - 75	65
Barometric pressure (mbar)		860 - 1060	950-1000

Site Description:

January 24, 2005 File on
Federal Communications Commission
Laboratory Division
7435 Oakland Mills Road
Columbia, MD 21046
Registration Number: 365520



Accredited by CNLA
Accreditation Number: 1313
Effective through: December 27, 2007



Accredited by NVLAP
NVLAP Lab Code: 200347-0
Effective through: September 30, 2008



Site Name: Quietek Corporation

Site Address: No.75-1, Wang-Yeh Valley, Yung-Hsing,
Chiung-Lin, Hsin-Chu County,
Taiwan, R.O.C.
TEL : 886-3-592-8858 / FAX : 886-3-592-8859
E-Mail : service@quietek.com

2. Conducted Emission

2.1. Test Equipment

The following test equipment are used during the test:

Conducted Emission / SR2

Instrument	Manufacturer	Type No.	Serial No	Cal. Date
4-Wire ISN	R & S	ENY 41	837032/001	2007/04/15
Artificial Mains Network	R & S	ENV4200	848411/010	2007/03/13
Double 2-Wire ISN	R & S	ENY 22	835354/008	2007/04/15
LISN	R & S	ESH3-Z5	825562/002	2007/03/31
Pulse Limiter	R & S	ZSH3Z2	357.8810.54	2007/07/19
Test Receiver	R & S	ESCS 30	100122	2007/02/21

Note: All equipment upon which need to calibrated are with calibration period of 1 year.

2.2. Test Setup

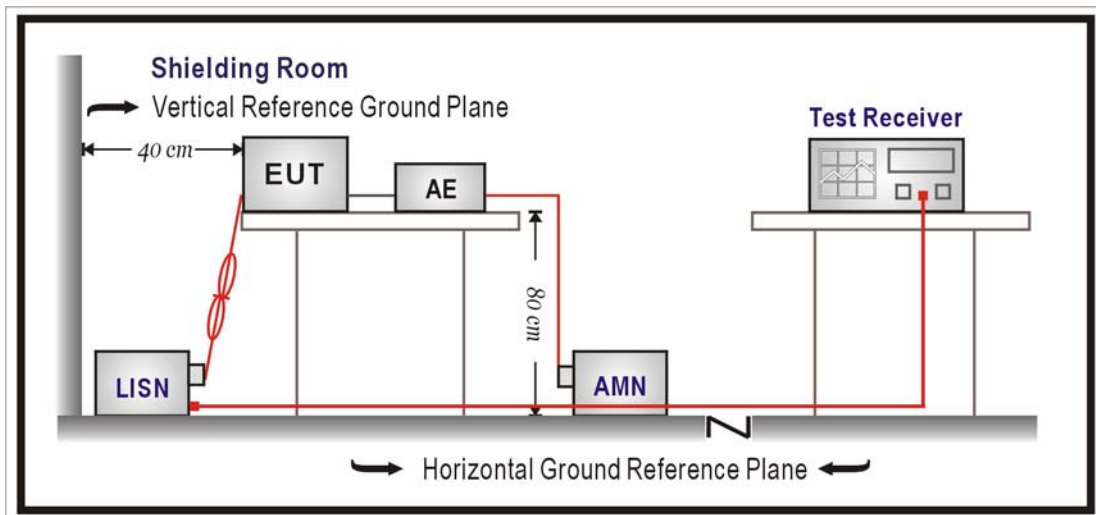

2.3. Limits

FCC Part 15 Subpart C Paragraph 15.207 Limits (dBuV)		
Frequency MHz	QP	AV
0.15 - 0.50	66-56	56-46
0.50-5.0	56	46
5.0 - 30	60	50

Remarks : In the above table, the tighter limit applies at the band edges.

2.4. Test Procedure

The EUT and simulators are connected to the main power through a line impedance stabilization network (L.I.S.N.). This provides a 50 ohm /50uH coupling impedance for the measuring equipment. The peripheral devices are also connected to the main power through a LISN that provides a 50ohm /50uH coupling impedance with 50ohm termination. (Please refers to the block diagram of the test setup and photographs.) Both sides of A.C. line are checked for maximum conducted interference. In order to find the maximum emission, the relative positions of equipment and all of the interface cables must be changed according to ANSI C63.4: 2003 on conducted measurement. Conducted emissions were invested over the frequency range from 0.15MHz to 30MHz using a receiver bandwidth of 9kHz.

2.5. Test Specification

According to FCC Part 15 Subpart C Paragraph 15.207: 2006

2.6. Uncertainty

The measurement uncertainty is defined as ± 2.26 dB.

2.7. Test Result

Site : ShieldingRoom 2	Time : 2007/10/25 - 14:15
Limit : CISPR_B_00M_QP	Margin : 0
EUT : Control Point 1000	Probe : QTK-LISN-SR2 - Line1
Power : AC 120V/60Hz	Note : Mode 1: Transmit (Adapter: OHE)

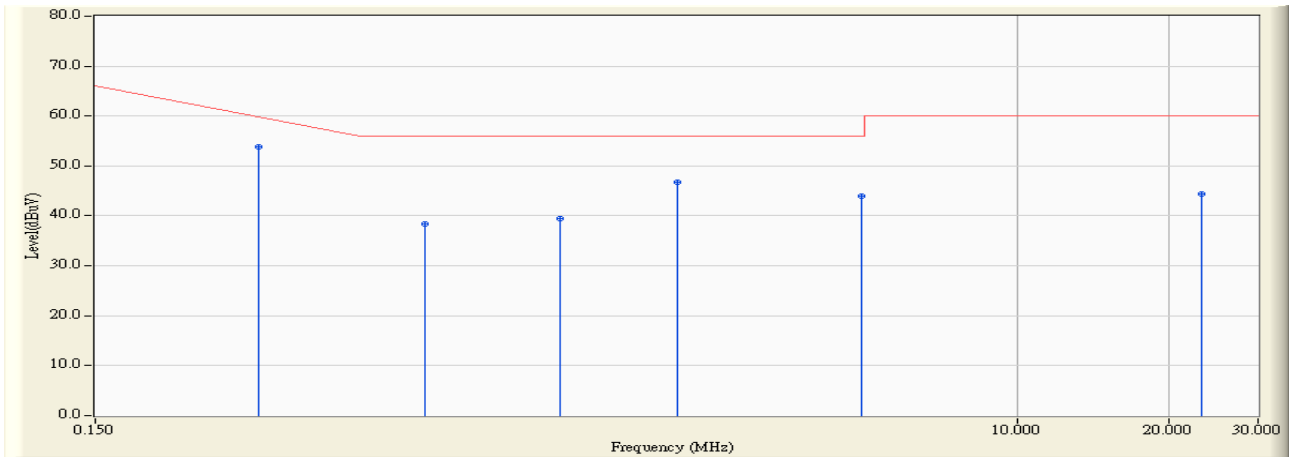

		Frequency (MHz)	Correct Factor (dB)	Reading Level (dBuV)	Measure Level (dBuV)	Margin (dB)	Limit (dBuV)	Detector Type
1	*	0.316	0.200	53.710	53.910	-7.347	61.257	QUASPEAK
2		0.673	0.210	38.120	38.330	-17.670	56.000	QUASPEAK
3		1.244	0.231	39.310	39.541	-16.459	56.000	QUASPEAK
4		2.128	0.320	46.460	46.780	-9.220	56.000	QUASPEAK
5		4.931	0.400	43.570	43.970	-12.030	56.000	QUASPEAK
6		23.129	1.270	43.180	44.450	-15.550	60.000	QUASPEAK

Note:

1. All Reading Levels are Quasi-Peak and average value.
2. " * ", means this data is the worst emission level.
3. Measurement Level = Reading Level + Correct Factor.

Site : ShieldingRoom 2	Time : 2007/10/25 - 14:15
Limit : CISPR_B_00M_AV	Margin : 0
EUT : Control Point 1000	Probe : QTK-LISN-SR2 - Line1
Power : AC 120V/60Hz	Note : Mode 1: Transmit (Adapter: OHE)

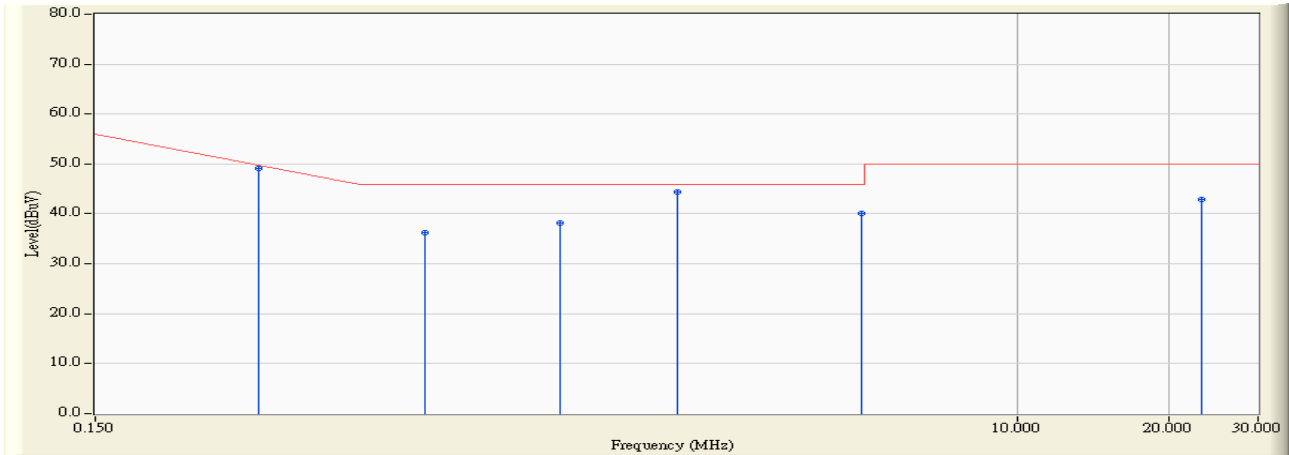

		Frequency (MHz)	Correct Factor (dB)	Reading Level (dBuV)	Measure Level (dBuV)	Margin (dB)	Limit (dBuV)	Detector Type
1	*	0.316	0.200	48.950	49.150	-1.107	51.257	AVERAGE
2		0.673	0.210	36.140	36.350	-9.650	46.000	AVERAGE
3		1.244	0.231	37.910	38.141	-7.859	46.000	AVERAGE
4		2.128	0.320	44.130	44.450	-1.550	46.000	AVERAGE
5		4.931	0.400	39.680	40.080	-5.920	46.000	AVERAGE
6		23.129	1.270	41.730	43.000	-7.000	50.000	AVERAGE

Note:

1. All Reading Levels are Quasi-Peak and average value.
2. " * ", means this data is the worst emission level.
3. Measurement Level = Reading Level + Correct Factor.

Site : ShieldingRoom 2	Time : 2007/10/25 - 14:21
Limit : CISPR_B_00M_QP	Margin : 0
EUT : Control Point 1000	Probe : QTK-LISN-SR2 - Line2
Power : AC 120V/60Hz	Note : Mode 1: Transmit (Adapter: OHE)

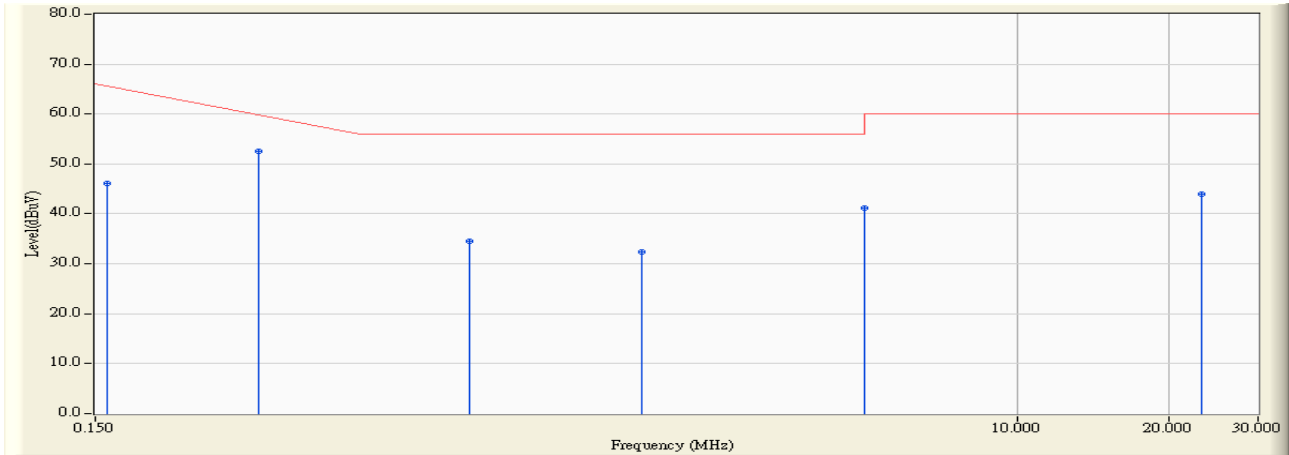

	Frequency (MHz)	Correct Factor (dB)	Reading Level (dBuV)	Measure Level (dBuV)	Margin (dB)	Limit (dBuV)	Detector Type
1	0.158	0.200	46.000	46.200	-19.571	65.771	QUASPEAK
2	* 0.315	0.200	52.420	52.620	-8.666	61.286	QUASPEAK
3	0.828	0.210	34.270	34.480	-21.520	56.000	QUASPEAK
4	1.813	0.220	32.250	32.470	-23.530	56.000	QUASPEAK
5	4.978	0.390	40.760	41.150	-14.850	56.000	QUASPEAK
6	23.129	0.970	43.040	44.010	-15.990	60.000	QUASPEAK

Note:

1. All Reading Levels are Quasi-Peak and average value.
2. " * ", means this data is the worst emission level.
3. Measurement Level = Reading Level + Correct Factor.

Site : ShieldingRoom 2	Time : 2007/10/25 - 14:21
Limit : CISPR_B_00M_AV	Margin : 0
EUT : Control Point 1000	Probe : QTK-LISN-SR2 - Line2
Power : AC 120V/60Hz	Note : Mode 1: Transmit (Adapter: OHE)

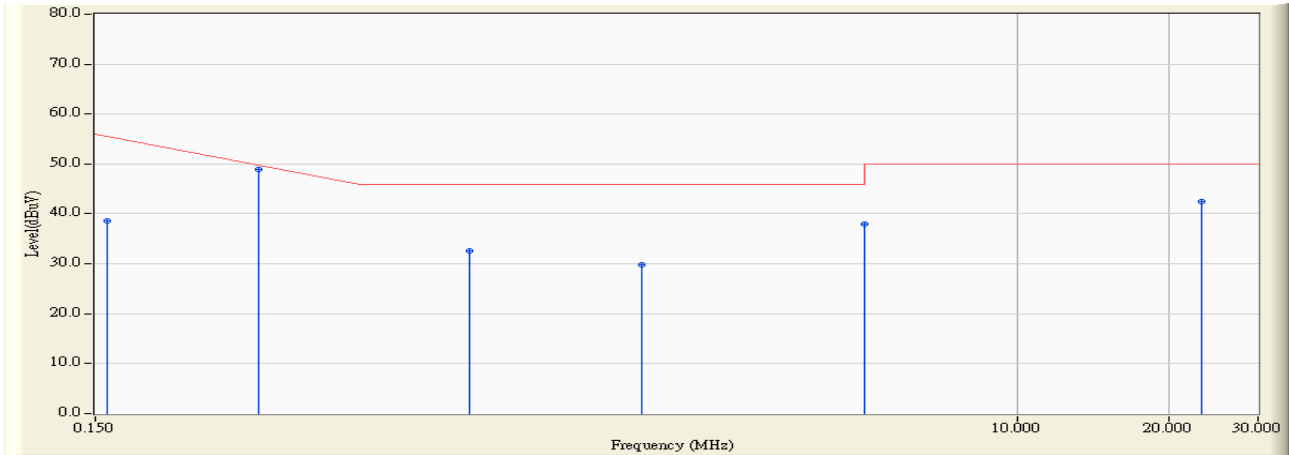

	Frequency (MHz)	Correct Factor (dB)	Reading Level (dBuV)	Measure Level (dBuV)	Margin (dB)	Limit (dBuV)	Detector Type
1	0.158	0.200	38.380	38.580	-17.191	55.771	AVERAGE
2	* 0.315	0.200	48.630	48.830	-1.456	51.286	AVERAGE
3	0.828	0.210	32.430	32.640	-13.360	46.000	AVERAGE
4	1.813	0.220	29.670	29.890	-16.110	46.000	AVERAGE
5	4.978	0.390	37.480	37.870	-8.130	46.000	AVERAGE
6	23.129	0.970	41.510	42.480	-7.520	50.000	AVERAGE

Note:

1. All Reading Levels are Quasi-Peak and average value.
2. " * ", means this data is the worst emission level.
3. Measurement Level = Reading Level + Correct Factor.

Site : ShieldingRoom 2	Time : 2007/10/25 - 14:28
Limit : CISPR_B_00M_QP	Margin : 0
EUT : Control Point 1000	Probe : QTK-LISN-SR2 - Line1
Power : AC 120V/60Hz	Note : Mode 2: Transmit (Adapter: BILLION)

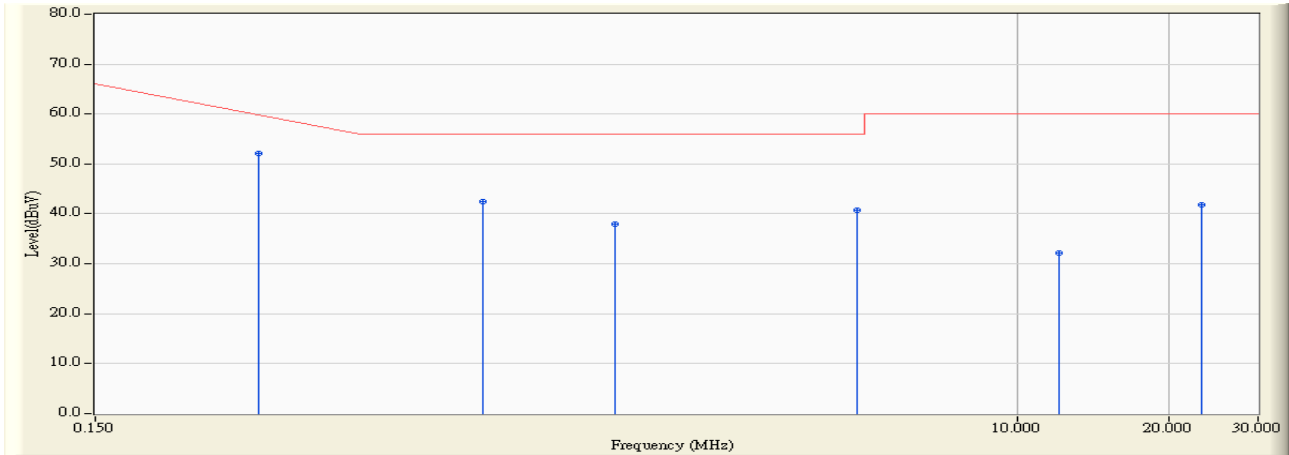

		Frequency (MHz)	Correct Factor (dB)	Reading Level (dBuV)	Measure Level (dBuV)	Margin (dB)	Limit (dBuV)	Detector Type
1	*	0.316	0.200	51.990	52.190	-9.067	61.257	QUASPEAK
2		0.875	0.210	42.300	42.510	-13.490	56.000	QUASPEAK
3		1.603	0.280	37.700	37.980	-18.020	56.000	QUASPEAK
4		4.836	0.400	40.400	40.800	-15.200	56.000	QUASPEAK
5		12.138	0.790	31.420	32.210	-27.790	60.000	QUASPEAK
6		23.130	1.270	40.620	41.890	-18.110	60.000	QUASPEAK

Note:

1. All Reading Levels are Quasi-Peak and average value.
2. " * ", means this data is the worst emission level.
3. Measurement Level = Reading Level + Correct Factor.

Site : ShieldingRoom 2	Time : 2007/10/25 - 14:28
Limit : CISPR_B_00M_AV	Margin : 0
EUT : Control Point 1000	Probe : QTK-LISN-SR2 - Line1
Power : AC 120V/60Hz	Note : Mode 2: Transmit (Adapter: BILLION)

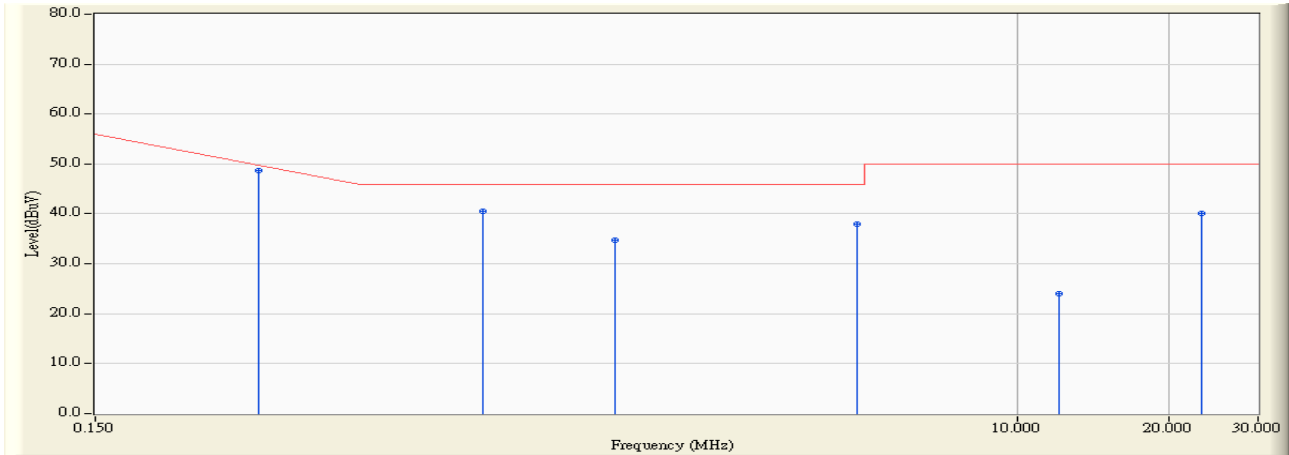

		Frequency (MHz)	Correct Factor (dB)	Reading Level (dBuV)	Measure Level (dBuV)	Margin (dB)	Limit (dBuV)	Detector Type
1	*	0.316	0.200	48.430	48.630	-1.627	51.257	AVERAGE
2		0.875	0.210	40.270	40.480	-5.520	46.000	AVERAGE
3		1.603	0.280	34.480	34.760	-11.240	46.000	AVERAGE
4		4.836	0.400	37.540	37.940	-8.060	46.000	AVERAGE
5		12.138	0.790	23.140	23.930	-26.070	50.000	AVERAGE
6		23.130	1.270	38.820	40.090	-9.910	50.000	AVERAGE

Note:

1. All Reading Levels are Quasi-Peak and average value.
2. " * ", means this data is the worst emission level.
3. Measurement Level = Reading Level + Correct Factor.

Site : ShieldingRoom 2	Time : 2007/10/25 - 14:34
Limit : CISPR_B_00M_QP	Margin : 0
EUT : Control Point 1000	Probe : QTK-LISN-SR2 - Line2
Power : AC 120V/60Hz	Note : Mode 2: Transmit (Adapter: BILLION)

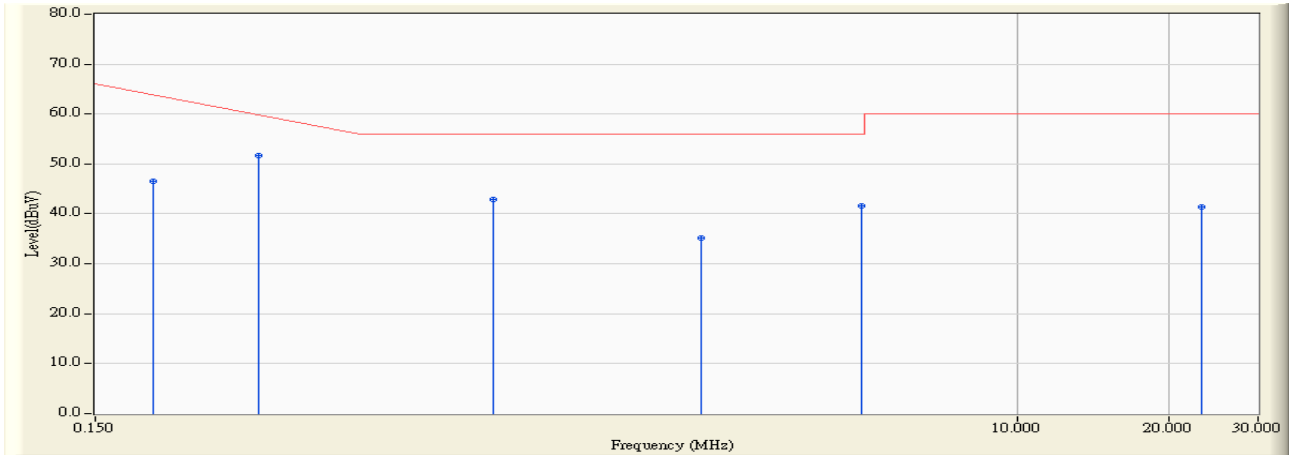

	Frequency (MHz)	Correct Factor (dB)	Reading Level (dBuV)	Measure Level (dBuV)	Margin (dB)	Limit (dBuV)	Detector Type
1	0.195	0.200	46.300	46.500	-18.214	64.714	QUASPEAK
2	* 0.316	0.200	51.390	51.590	-9.667	61.257	QUASPEAK
3	0.922	0.210	42.660	42.870	-13.130	56.000	QUASPEAK
4	2.378	0.250	34.920	35.170	-20.830	56.000	QUASPEAK
5	4.933	0.390	41.260	41.650	-14.350	56.000	QUASPEAK
6	23.130	0.970	40.520	41.490	-18.510	60.000	QUASPEAK

Note:

1. All Reading Levels are Quasi-Peak and average value.
2. " * ", means this data is the worst emission level.
3. Measurement Level = Reading Level + Correct Factor.

Site : ShieldingRoom 2	Time : 2007/10/25 - 14:34
Limit : CISPR_B_00M_AV	Margin : 0
EUT : Control Point 1000	Probe : QTK-LISN-SR2 - Line2
Power : AC 120V/60Hz	Note : Mode 2: Transmit (Adapter: BILLION)

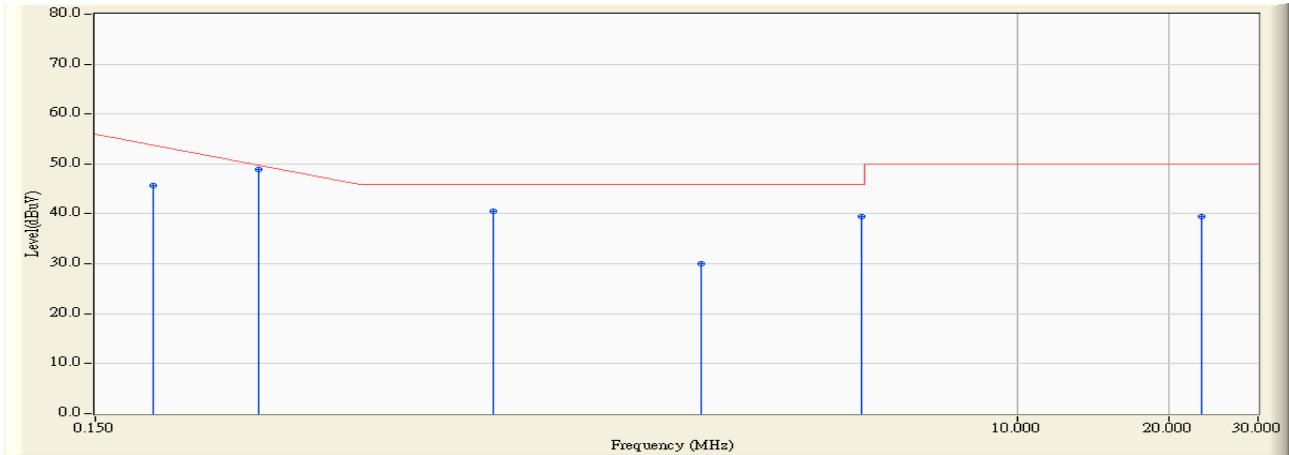

		Frequency (MHz)	Correct Factor (dB)	Reading Level (dBuV)	Measure Level (dBuV)	Margin (dB)	Limit (dBuV)	Detector Type
1		0.195	0.200	45.400	45.600	-9.114	54.714	AVERAGE
2	*	0.316	0.200	48.750	48.950	-1.307	51.257	AVERAGE
3		0.922	0.210	40.430	40.640	-5.360	46.000	AVERAGE
4		2.378	0.250	29.690	29.940	-16.060	46.000	AVERAGE
5		4.933	0.390	39.040	39.430	-6.570	46.000	AVERAGE
6		23.130	0.970	38.440	39.410	-10.590	50.000	AVERAGE

Note:

1. All Reading Levels are Quasi-Peak and average value.
2. " * ", means this data is the worst emission level.
3. Measurement Level = Reading Level + Correct Factor.

3. Radiated Emission

3.1. Test Equipment

The following test equipment are used during the test:

Radiated Emission / Site1

Instrument	Manufacturer	Type No.	Serial No	Cal. Date
Bilog Antenna	Schaffner Chase	CBL6112B	2895	2007/09/03
Horn Antenna	Electro Metrics	EM-6961	103325	2007/03/15
Pre-Amplifier	HP	8449B	3008A01123	2006/11/15
Pre-Amplifier	Quietek	AP-025C	N/A	N/A
Spectrum Analyzer	R & S	FSP40	100005	2007/08/25
Spectrum Analyzer	Advantest	R3162	120300649	2006/11/24
Test Receiver	R & S	ESCS 30	825442/017	2007/02/13

- Note: 1. All equipments that need to calibrate are with calibration period of 1 year.
 2. "N/A" Ca1.Date is used to Pre-test, not final test.

3.2. Test Setup

Under 1GHz Test Setup:

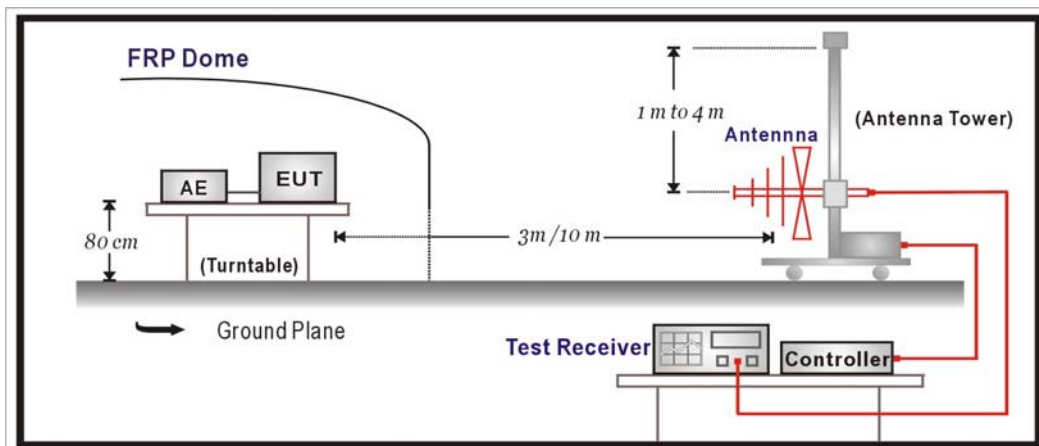

Above 1GHz Test Setup:

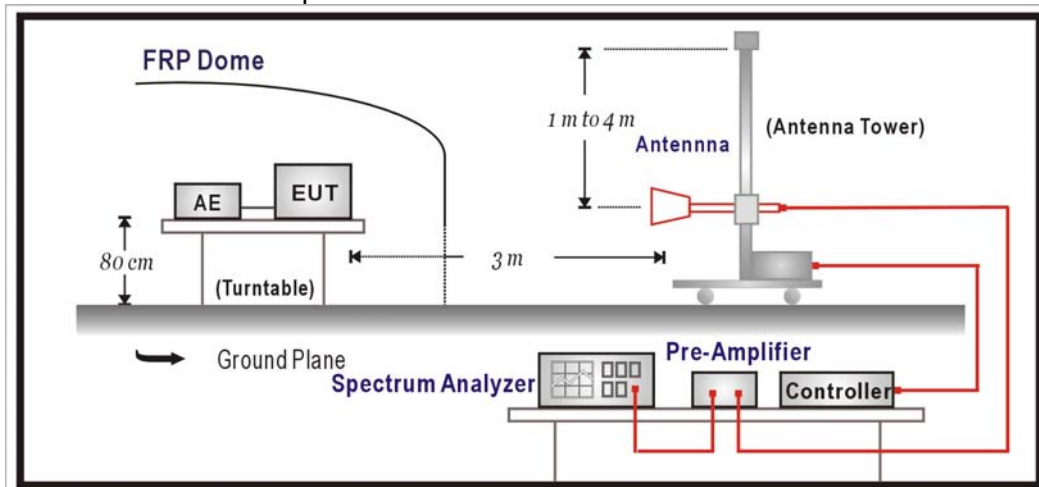

3.3. Limits

➤ Fundamental and Harmonics Emission Limits

FCC Part 15 Subpart C Paragraph 15.249 Limits				
Fundamental Frequency MHz	Field Strength of Fundamental		Field Strength of Harmonics	
	mV/m	dBuV/m	uV/m	dBuV/m
902-928	50	94	500	54
2400-2483.5	50	94	500	54
5725-5875	50	94	500	54

- Remarks :
1. RF Voltage (dBuV) = 20 log RF Voltage (uV)
 2. Distance refers to the distance in meters between the measuring instrument antenna and the closed point of any part of the device or system.
 3. The emission limit in this paragraph is based on measurement instrumentation employing an average detector.

➤ Spurious electric field strength limits

FCC Part 15 Subpart C Paragraph 15.209 Limits			
Frequency MHz	uV/m	dBuV/m	Measurement distance (meter)
1.705-30	30	29.5	30
30-88	100	40	3
88-216	150	43.5	3
216-960	200	46	3
Above 960	500	54	3

- Remarks :
1. RF Voltage (dBuV) = 20 log RF Voltage (uV)
 2. In the Above Table, the tighter limit applies at the band edges.
 3. Distance refers to the distance in meters between the measuring instrument antenna and the closed point of any part of the device or system.

3.4. Test Procedure

The EUT and its simulators are placed on a turn table which is 0.8 meter above ground. The turn table can rotate 360 degrees to determine the position of the maximum emission level. The antenna can move up and down between 1 meter and 4 meters to find out the maximum emission level.

Both horizontal and vertical polarization of the antenna are set on measurement. In order to find the maximum emission, all of the interface cables must be manipulated according to ANSI C63.4:2003 on radiated measurement.

On any frequency or frequencies below or equal to 1000 MHz, the limits shown are based on measuring equipment employing a quasi-peak detector function and on any frequency or frequencies above 1000 MHz the radiated limits shown are based upon the use of measurement instrumentation employing an average detector function. When average radiated emission measurement are included emission measurement below 1000 MHz, there also is a limit on the radio frequency emissions, as measured using instrumentation with a peak detector function, corresponding to 20 dB above the maximum permitted average limit. The bandwidth below 1GHz setting on the field strength meter is 120 kHz and above 1GHz is 1MHz.

3.5. Test Specification

According to FCC Part 15 Subpart C Paragraph 15.209 and Paragraph 15.249: 2006

3.6. Uncertainty

The measurement uncertainty
 30MHz~1GHz as $\pm 3.19\text{dB}$
 1GHz~26.5GHz as $\pm 3.9\text{dB}$

3.7. Test Result

Fundamental :

Site : Site 1	Time : 2007/10/26 - 14:55
Limit : FCC_PART15.249(30M-21G)_F_03M_PK	Margin : 6
EUT : Control Point 1000	Probe : FCC_RF_30-1G(2007) - HORIZONTAL
Power : AC 120V/60Hz	Note : Mode 1: Transmit (Adapter: OHE) Fundamental

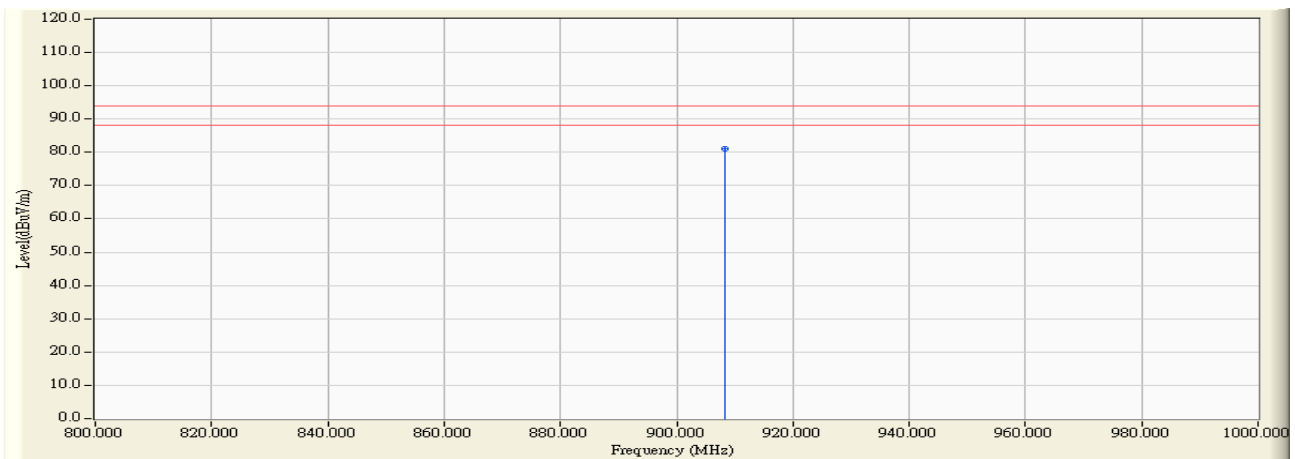

		Frequency (MHz)	Correct Factor (dB)	Reading Level (dBuV)	Measure Level (dBuV/m)	Margin (dB)	Limit (dBuV/m)	Detector Type
1	*	908.380	26.674	54.340	81.014	-12.986	94.000	PEAK

Note:

1. All Readings below 1GHz are Quasi-Peak, above are performed with peak and/or average measurements as necessary.
2. “ * ”, means this data is the worst emission level.
3. Measurement Level = Reading Level + Correct Factor.
4. The average measurement was not performed when the peak measured data under the limit of average detection. If the readings given are average, peak measurement should also be supplied.

Site : Site 1	Time : 2007/10/26 - 14:57
Limit : FCC_PART15.249(30M-21G)_F_03M_PK	Margin : 6
EUT : Control Point 1000	Probe : FCC_RF_30-1G(2007) - VERTICAL
Power : AC 120V/60Hz	Note : Mode 1: Transmit (Adapter: OHE) Fundamental

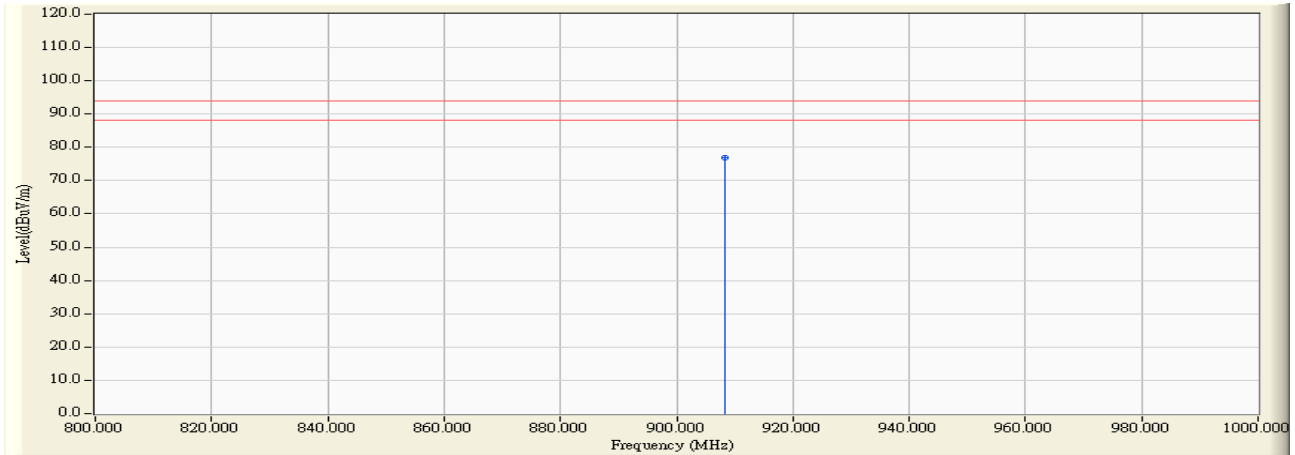

		Frequency (MHz)	Correct Factor (dB)	Reading Level (dBuV)	Measure Level (dBuV/m)	Margin (dB)	Limit (dBuV/m)	Detector Type
1	*	908.400	22.426	54.450	76.876	-17.124	94.000	PEAK

Note:

1. All Readings below 1GHz are Quasi-Peak, above are performed with peak and/or average measurements as necessary.
2. “ * ”, means this data is the worst emission level.
3. Measurement Level = Reading Level + Correct Factor.
4. The average measurement was not performed when the peak measured data under the limit of average detection. If the readings given are average, peak measurement should also be supplied.

30 MHz-1 GHz Spurious:

Site : Site 1	Time : 2007/10/26 - 17:02
Limit : FCC_CLASS_B_03M_QP	Margin : 6
EUT : Control Point 1000	Probe : FCC_RF_30-1G(200605) - HORIZONTAL
Power : AC 120V/60Hz	Note : Mode 1: Transmit (Adapter: OHE)

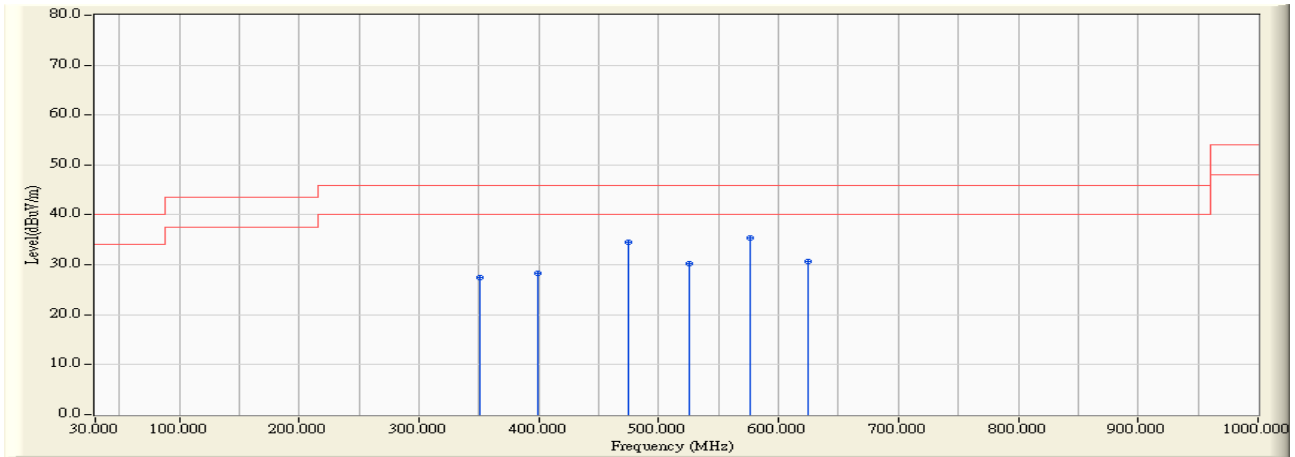

	Frequency (MHz)	Correct Factor (dB)	Reading Level (dBuV)	Measure Level (dBuV/m)	Margin (dB)	Limit (dBuV/m)	Detector Type
1	350.741	-81.760	109.109	27.349	-18.651	46.000	PEAK
2	399.339	-81.760	110.006	28.246	-17.754	46.000	PEAK
3	475.150	-81.760	116.358	34.598	-11.402	46.000	PEAK
4	525.691	-81.760	111.952	30.192	-15.808	46.000	PEAK
5	* 576.232	-81.760	117.154	35.394	-10.606	46.000	PEAK
6	624.830	-81.760	112.525	30.765	-15.235	46.000	PEAK

Note:

1. All Reading Levels are Quasi-Peak value.
2. “ * ”, means this data is the worst emission level.
3. Measurement Level = Reading Level + Correct Factor.

Site : Site 1	Time : 2007/10/26 - 17:59
Limit : FCC_CLASS_B_03M_QP	Margin : 6
EUT : Control Point 1000	Probe : FCC_RF_30-1G(200605) - VERTICAL
Power : AC 120V/60Hz	Note : Mode 1: Transmit (Adapter: OHE)

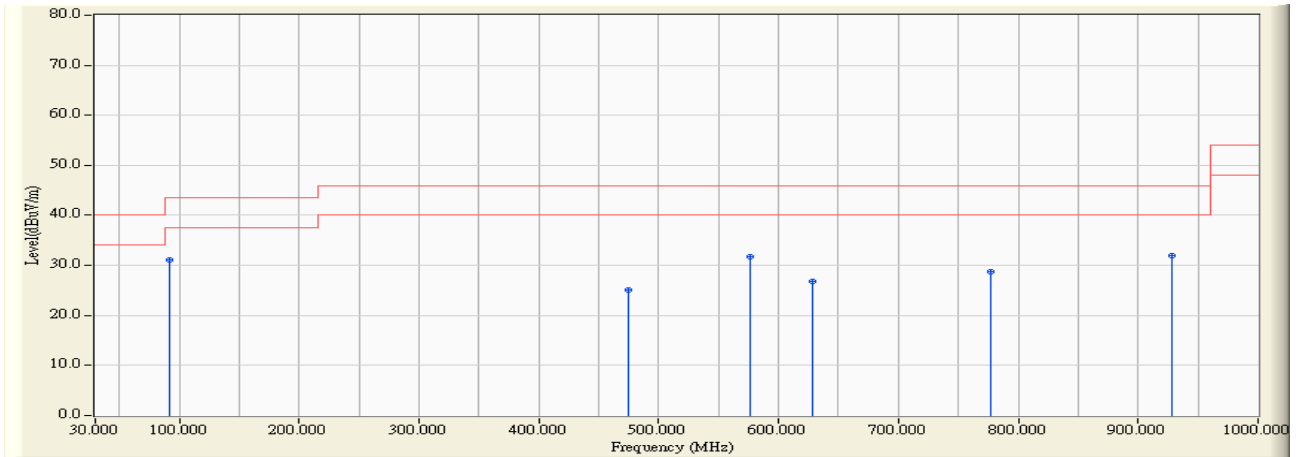

		Frequency (MHz)	Correct Factor (dB)	Reading Level (dBuV)	Measure Level (dBuV/m)	Margin (dB)	Limit (dBuV/m)	Detector Type
1	*	92.204	-81.760	112.823	31.063	-12.437	43.500	PEAK
2		475.150	-81.760	106.773	25.013	-20.987	46.000	PEAK
3		576.232	-81.760	113.511	31.751	-14.249	46.000	PEAK
4		628.717	-81.760	108.668	26.908	-19.092	46.000	PEAK
5		776.453	-81.760	110.393	28.633	-17.367	46.000	PEAK
6		928.076	-81.760	113.739	31.979	-14.021	46.000	PEAK

Note:

1. All Reading Levels are Quasi-Peak value.
2. “ * ”, means this data is the worst emission level.
3. Measurement Level = Reading Level + Correct Factor.

Site : Site 1	Time : 2007/10/26 - 16:52
Limit : FCC_CLASS_B_03M_QP	Margin : 6
EUT : Control Point 1000	Probe : FCC_RF_30-1G(2007) - HORIZONTAL
Power : AC 120V/60Hz	Note : Mode 2: Transmit (Adapter: BILLION)

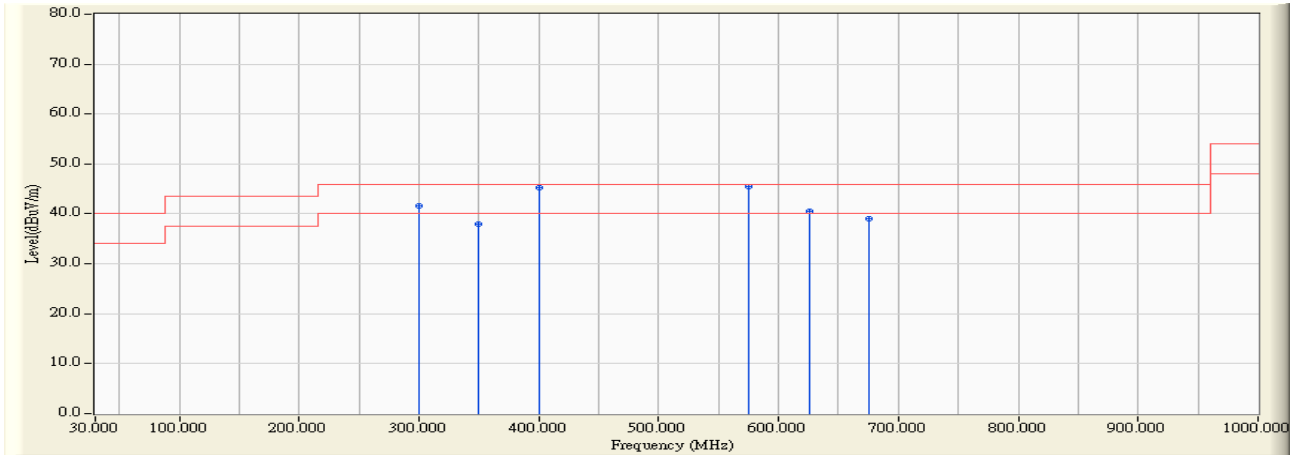

	Frequency (MHz)	Correct Factor (dB)	Reading Level (dBuV)	Measure Level (dBuV/m)	Margin (dB)	Limit (dBuV/m)	Detector Type
1	299.660	-32.750	74.305	41.555	-4.445	46.000	PEAK
2	350.100	-33.970	71.859	37.889	-8.111	46.000	PEAK
3	400.540	-28.310	73.578	45.268	-0.732	46.000	PEAK
4	* 575.140	-24.560	70.016	45.456	-0.544	46.000	PEAK
5	625.580	-27.530	68.049	40.519	-5.481	46.000	PEAK
6	676.020	-28.460	67.507	39.047	-6.953	46.000	PEAK

Note:

1. All Reading Levels are Quasi-Peak value.
2. “ * ”, means this data is the worst emission level.
3. Measurement Level = Reading Level + Correct Factor.

Site : Site 1	Time : 2007/10/26 - 16:58
Limit : FCC_CLASS_B_03M_QP	Margin : 6
EUT : Control Point 1000	Probe : FCC_RF_30-1G(2007) - VERTICAL
Power : AC 120V/60Hz	Note : Mode 2: Transmit (Adapter: BILLION)

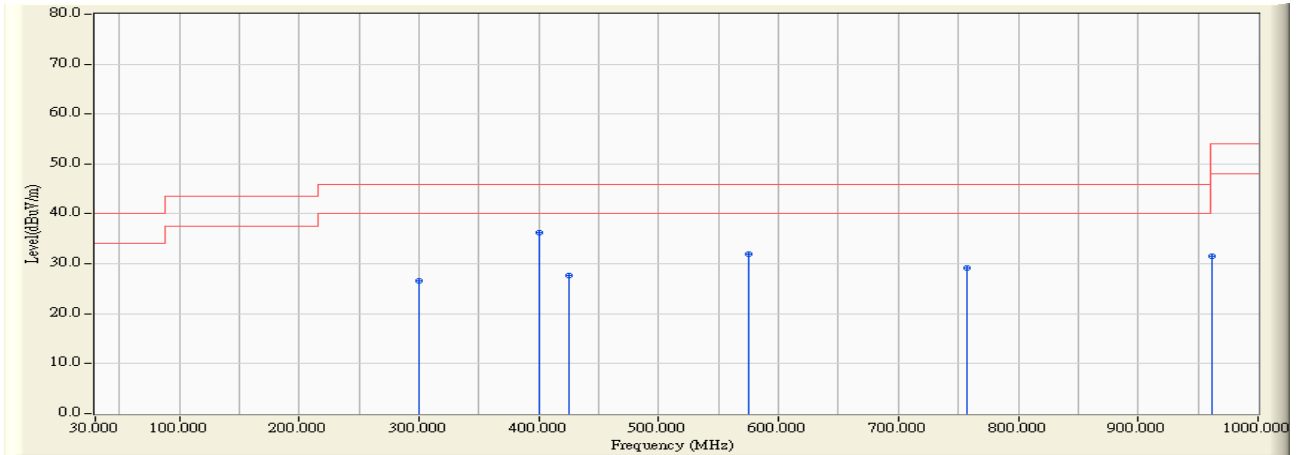

	Frequency (MHz)	Correct Factor (dB)	Reading Level (dBuV)	Measure Level (dBuV/m)	Margin (dB)	Limit (dBuV/m)	Detector Type
1	299.660	-38.160	64.661	26.501	-19.499	46.000	PEAK
2	* 400.540	-29.500	65.756	36.256	-9.744	46.000	PEAK
3	425.760	-32.520	60.217	27.697	-18.303	46.000	PEAK
4	575.140	-26.680	58.639	31.959	-14.041	46.000	PEAK
5	757.500	-27.420	56.629	29.209	-16.791	46.000	PEAK
6	961.200	-23.150	54.717	31.567	-22.433	54.000	PEAK

Note:

1. All Reading Levels are Quasi-Peak value.
2. “ * ”, means this data is the worst emission level.
3. Measurement Level = Reading Level + Correct Factor.

Spurious and Harmonics Emission :

Site : Site 1	Time : 2007/10/23 - 20:23
Limit : FCC_SpartC_15.247_H_03M_PK	Margin : 6
EUT : Control Point 1000	Probe : FCC_CB4_1-18G(2007) - HORIZONTAL
Power : AC 120V/60Hz	Note : Mode 1: Transmit (Adapter: OHE)

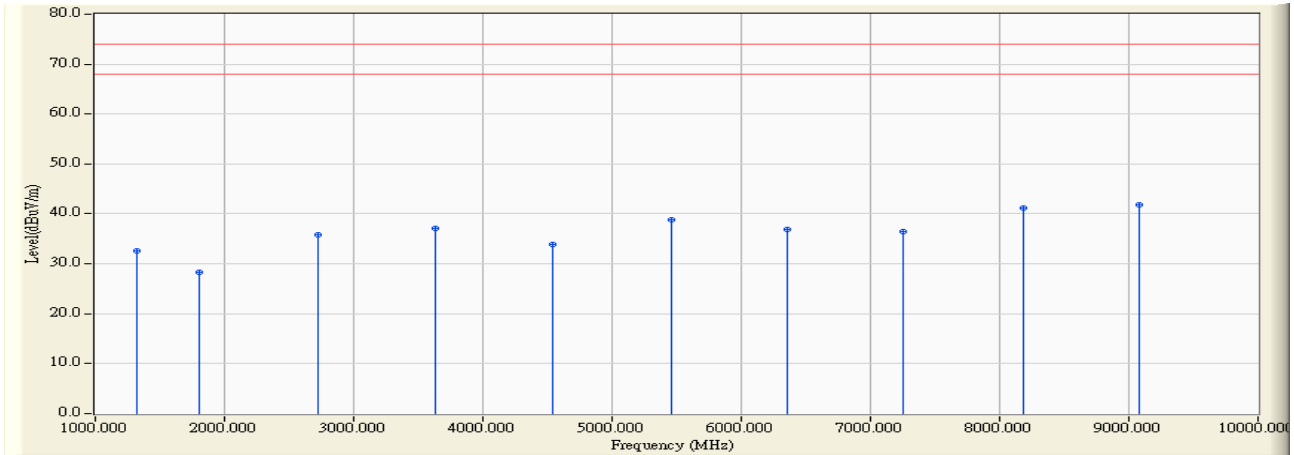

	Frequency (MHz)	Correct Factor (dB)	Reading Level (dBuV)	Measure Level (dBuV/m)	Margin (dB)	Peak Limit (dBuV/m)	Average Limit (dBuV/m)	Detector Type
1	1324.640	-13.938	46.600	32.662	-41.338	74.000	54.00	PEAK
2	1809.610	-7.282	35.660	28.379	-45.621	74.000	54.00	PEAK
3	2723.440	-1.196	37.060	35.864	-38.136	74.000	54.00	PEAK
4	3637.270	2.506	34.630	37.136	-36.864	74.000	54.00	PEAK
5	4543.080	0.296	33.520	33.817	-40.183	74.000	54.00	PEAK
6	5454.490	1.393	37.400	38.793	-35.207	74.000	54.00	PEAK
7	6356.710	-0.115	37.060	36.945	-37.055	74.000	54.00	PEAK
8	7258.510	0.105	36.410	36.514	-37.486	74.000	54.00	PEAK
9	8178.350	3.611	37.620	41.230	-32.770	74.000	54.00	PEAK
10	* 9080.160	5.102	36.780	41.883	-32.117	74.000	54.00	PEAK

Note:

1. All Readings below 1GHz are Quasi-Peak, above are performed with peak and/or average measurements as necessary.
2. “ * ”, means this data is the worst emission level.
3. Measurement Level = Reading Level + Correct Factor.
4. The average measurement was not performed when the peak measured data under the limit of average detection. If the readings given are average, peak measurement should also be supplied.

Site : Site 1	Time : 2007/10/23 - 20:39
Limit : FCC_SpartC_15.247_H_03M_PK	Margin : 6
EUT : Control Point 1000	Probe : FCC_CB4_1-18G(2007) - VERTICAL
Power : AC 120V/60Hz	Note : Mode 1: Transmit (Adapter: OHE)

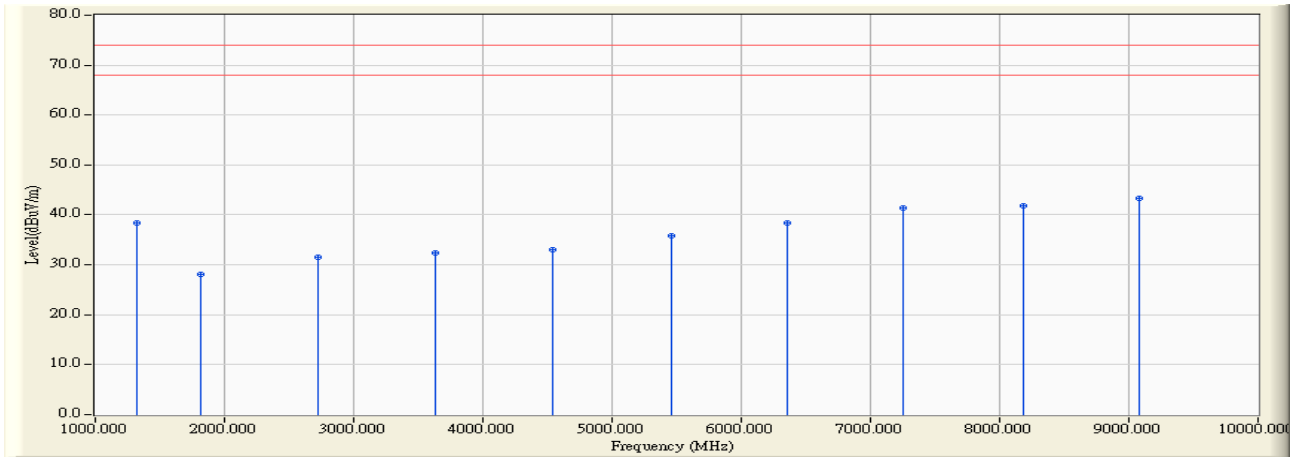

	Frequency (MHz)	Correct Factor (dB)	Reading Level (dBuV)	Measure Level (dBuV/m)	Margin (dB)	Peak Limit (dBuV/m)	Average Limit (dBuV/m)	Detector Type
1	1324.640	-6.401	44.730	38.329	-35.671	74.000	54.00	PEAK
2	1817.630	-6.651	34.830	28.179	-45.821	74.000	54.00	PEAK
3	2723.440	-4.486	36.060	31.574	-42.426	74.000	54.00	PEAK
4	3637.270	-1.587	33.980	32.394	-41.606	74.000	54.00	PEAK
5	4543.080	-1.382	34.400	33.019	-40.981	74.000	54.00	PEAK
6	5454.490	-1.521	37.360	35.840	-38.160	74.000	54.00	PEAK
7	6356.710	1.401	37.010	38.411	-35.589	74.000	54.00	PEAK
8	7258.510	3.903	37.400	41.303	-32.697	74.000	54.00	PEAK
9	8178.350	4.661	37.250	41.910	-32.090	74.000	54.00	PEAK
10	* 9080.160	5.526	37.730	43.256	-30.744	74.000	54.00	PEAK

Note:

1. All Readings below 1GHz are Quasi-Peak, above are performed with peak and/or average measurements as necessary.
2. “ * ”, means this data is the worst emission level.
3. Measurement Level = Reading Level + Correct Factor.
4. The average measurement was not performed when the peak measured data under the limit of average detection. If the readings given are average, peak measurement should also be supplied.

4. Band Edge

4.1. Test Equipment

The following test equipment are used during the test:

RF Conducted Measurement:				
Item	Equipment	Manufacturer	Model No. / Serial No.	Last Cal.
1	Spectrum Analyzer	R & S	FSP / 100561	Mar., 2007
2	No.1 OATS			Sep., 2007
RF Radiated Measurement:				
Item	Equipment	Manufacturer	Model No. / Serial No.	Last Cal.
1	X Spectrum Analyzer	R & S	FSP40 / 100005	Aug., 2007
2	X Pre-Amplifier	HP	8449B / 3008A01123	Feb., 2007
3	Loop Antenna	R & S	HFH2-Z2 / 833799/004	Sep., 2007
4	BiconiLog Antenna	Schwarzbeck	VULB 9166 / 1061	Sep., 2007
5	Bilog Antenna	Chase	CBL6112B / 2455	Sep., 2007
6	X Horn Antenna	Schwarzbeck	BBHA 9120D / BBHA9120D312	Sep., 2007
7	No.1 OATS			Sep., 2007

- Note: 1. All equipments that need to calibrate are with calibration period of 1 year.
 2. Mark "X" test instruments are used to measure the final test results.

4.2. Test Setup

RF Conducted Measurement:

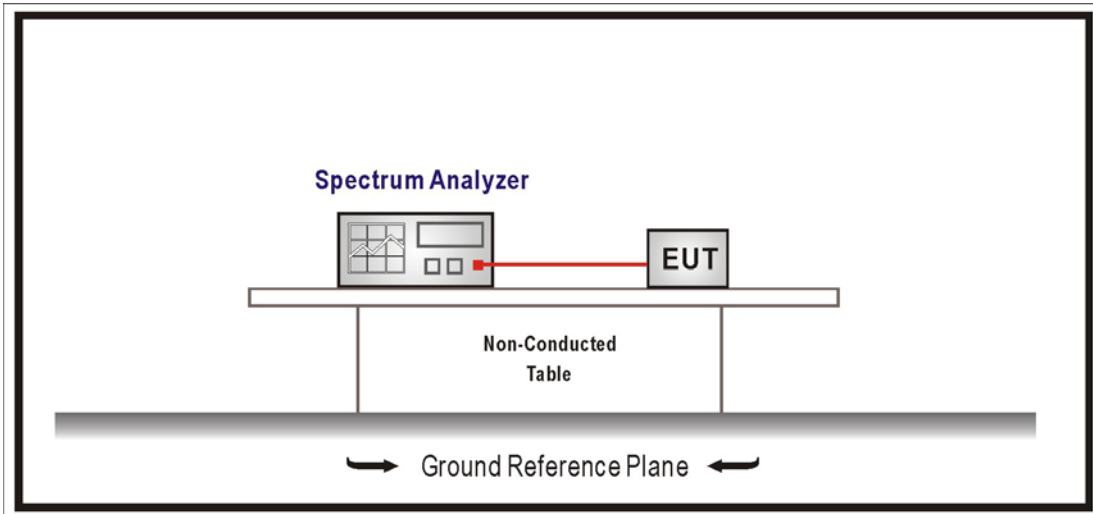

RF Radiated Measurement:

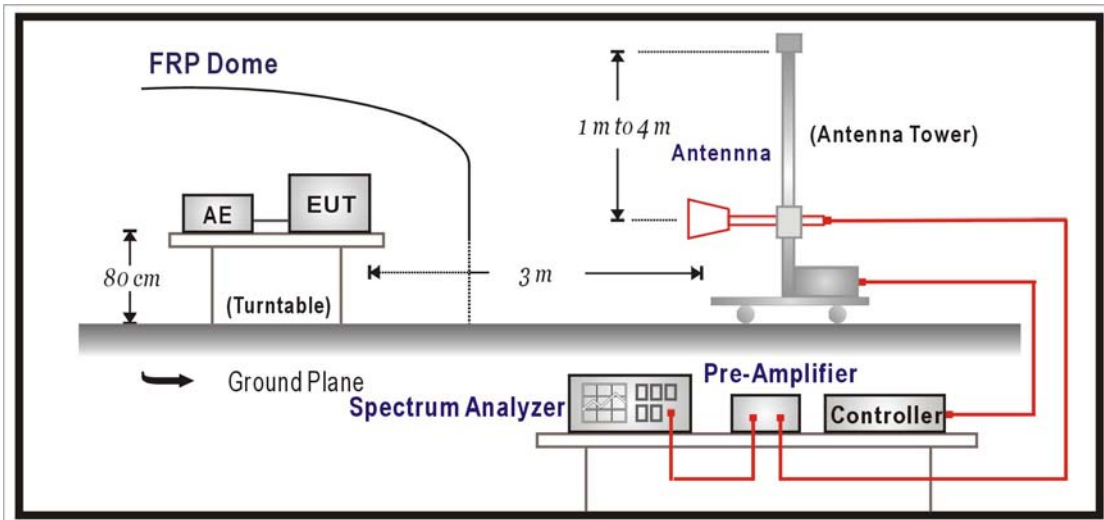

4.3. Limits

In any 100 kHz bandwidth outside the frequency band in which the spread spectrum intentional radiator is operating, the radio frequency power that is produced by the intentional radiator shall be at least 50 dB below that in the 100 kHz bandwidth within the band that contains the highest level of the desired power, based on either an RF conducted or a radiated measurement. Attenuation below the general limits specified in Section 15.209(a) is not required. In addition, radiated emissions which fall in the restricted bands, as defined in Section 15.205(a), must also comply with the radiated emission limits specified in Section 15.209(a) (see Section 15.205(c)).

4.4. Test Procedure

The EUT and its simulators are placed on a turn table which is 0.8 meter above ground. The turn table can rotate 360 degrees to determine the position of the maximum emission level. The EUT was positioned such that the distance from antenna to the EUT was 3 meters.

The antenna can move up and down between 1 meter and 4 meters to find out the maximum emission level.

Both horizontal and vertical polarization of the antenna are set on measurement. In order to find the maximum emission, all of the interface cables must be manipulated according to ANSI C63.4:2003 on radiated measurement.

The bandwidth below 1GHz setting on the field strength meter is 120 kHz, above 1GHz are 1 MHz.

4.5. Test Specification

According to FCC Part 15 Subpart C Paragraph 15.249: 2006

4.6. Uncertainty

The measurement uncertainty

Conducted is defined as $\pm 1.27\text{dB}$

Radiated is defined as $\pm 3.9\text{dB}$

4.7. Test Result

Site : Site 1	Time : 2007/10/29 - 20:24
Limit : FCC_SpartC_15.209_03M_PK	Margin : 6
EUT : Control Point 1000	Probe : FCC_RF_30-1G(2007) - HORIZONTAL
Power : AC 120V/60Hz	Note : Mode 1: Transmit (Adapter: OHE) Bandedge

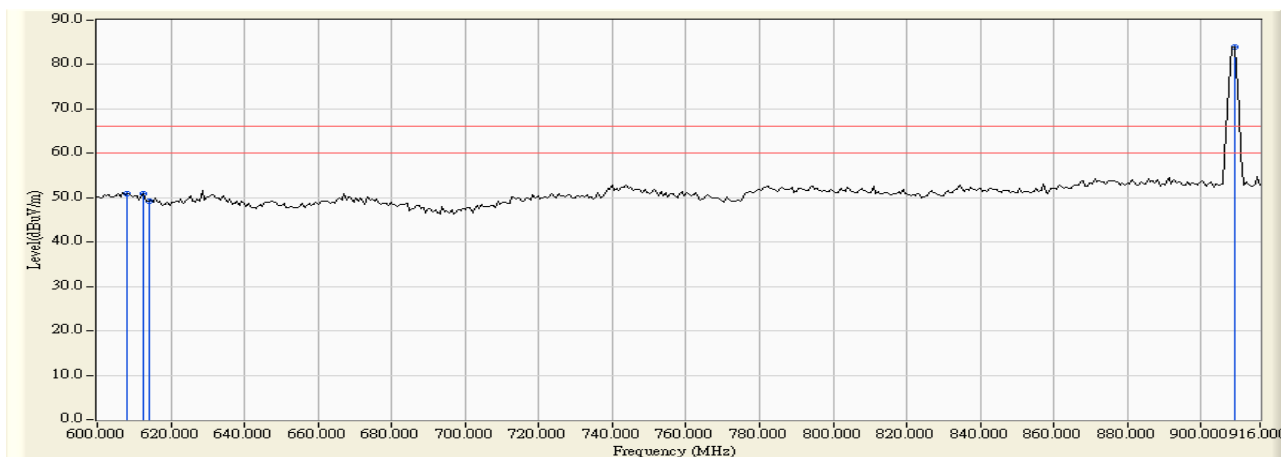

	Frequency (MHz)	Correct Factor (dB)	Reading Level (dBuV)	Measure Level (dBuV/m)	Margin (dB)	Peak Limit (dBuV/m)	Average Limit (dBuV/m)	Detector Type
1	608.000	25.312	25.502	50.814	-15.206	74.000	54.00	PEAK
2	* 612.665	24.179	26.725	50.904	-15.116	74.000	54.00	PEAK
3	614.000	23.825	25.338	49.163	-16.857	74.000	54.00	PEAK
4	909.034	26.653	57.330	83.983	17.963	74.000	54.00	PEAK

Note:

1. All Readings below 1GHz are Quasi-Peak, above are performed with peak and/or average measurements as necessary.
2. “ * ”, means this data is the worst emission level.
3. Measurement Level = Reading Level + Correct Factor.
4. The average measurement was not performed when the peak measured data under the limit of average detection. If the readings given are average, peak measurement should also be supplied.

Site : Site 1	Time : 2007/10/29 - 20:43
Limit : FCC_SpartC_15.209_03M_PK	Margin : 6
EUT : Control Point 1000	Probe : FCC_RF_30-1G(2007) - VERTICAL
Power : AC 120V/60Hz	Note : Mode 1: Transmit (Adapter: OHE) Bandedge

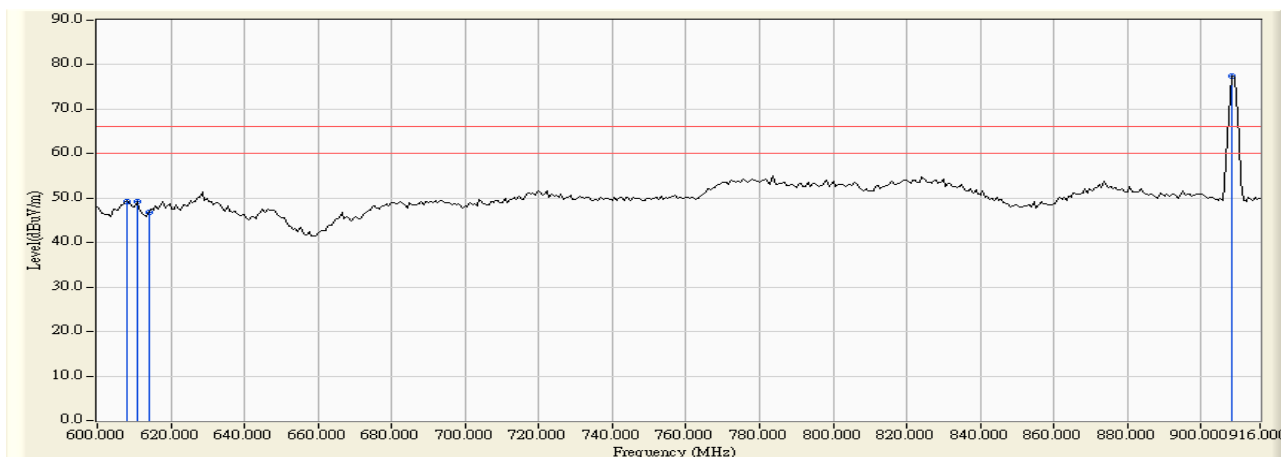

	Frequency (MHz)	Correct Factor (dB)	Reading Level (dBuV)	Measure Level (dBuV/m)	Margin (dB)	Peak Limit (dBuV/m)	Average Limit (dBuV/m)	Detector Type
1	608.000	23.369	25.949	49.318	-16.702	74.000	54.00	PEAK
2	* 610.766	21.762	27.451	49.213	-16.807	74.000	54.00	PEAK
3	614.000	20.961	25.830	46.791	-19.229	74.000	54.00	PEAK
4	908.401	22.426	54.940	77.366	11.346	74.000	54.00	PEAK

Note:

1. All Readings below 1GHz are Quasi-Peak, above are performed with peak and/or average measurements as necessary.
2. “ * ”, means this data is the worst emission level.
3. Measurement Level = Reading Level + Correct Factor.
4. The average measurement was not performed when the peak measured data under the limit of average detection. If the readings given are average, peak measurement should also be supplied.

Site : Site 1	Time : 2007/10/29 - 20:27
Limit : FCC_SpartC_15.209_03M_AV	Margin : 6
EUT : Control Point 1000	Probe : FCC_RF_30-1G(2007) - HORIZONTAL
Power : AC 120V/60Hz	Note : Mode 1: Transmit (Adapter: OHE) Bandedge

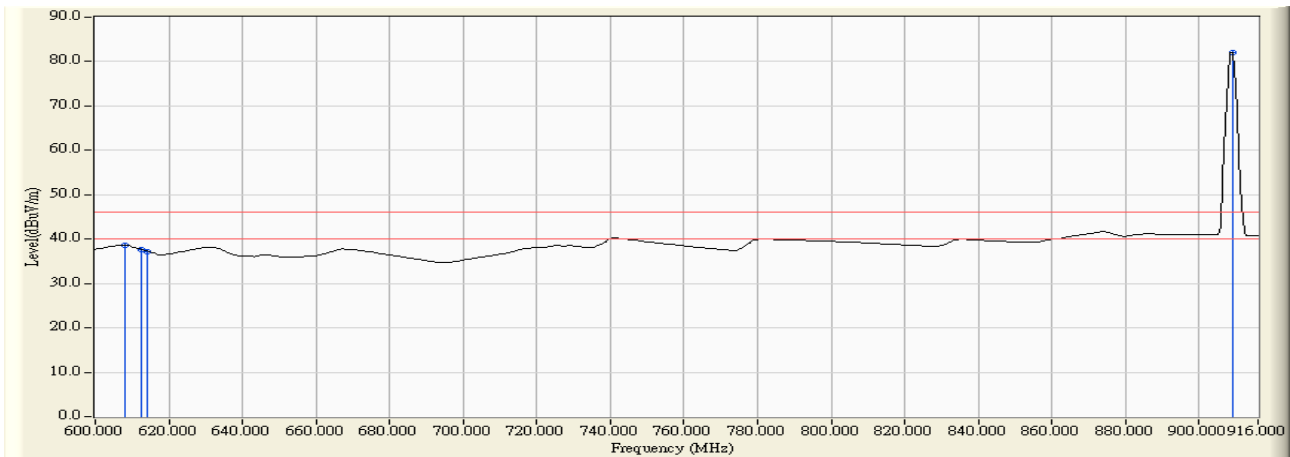

	Frequency (MHz)	Correct Factor (dB)	Reading Level (dBuV)	Measure Level (dBuV/m)	Margin (dB)	Peak Limit (dBuV/m)	Average Limit (dBuV/m)	Detector Type
1	608.000	25.312	13.363	38.675	-7.345	74.000	54.00	AVERAGE
2	* 612.665	24.179	13.457	37.636	-8.384	74.000	54.00	AVERAGE
3	614.000	23.825	13.452	37.277	-8.743	74.000	54.00	AVERAGE
4	909.034	26.653	55.431	82.084	36.064	74.000	54.00	AVERAGE

Note:

1. All Readings below 1GHz are Quasi-Peak, above are performed with peak and/or average measurements as necessary.
2. “ * ”, means this data is the worst emission level.
3. Measurement Level = Reading Level + Correct Factor.
4. The average measurement was not performed when the peak measured data under the limit of average detection. If the readings given are average, peak measurement should also be supplied.

Site : Site 1	Time : 2007/10/29 - 20:46
Limit : FCC_SpartC_15.209_03M_AV	Margin : 6
EUT : Control Point 1000	Probe : FCC_RF_30-1G(2007) - VERTICAL
Power : AC 120V/60Hz	Note : Mode 1: Transmit (Adapter: OHE) Bandedge

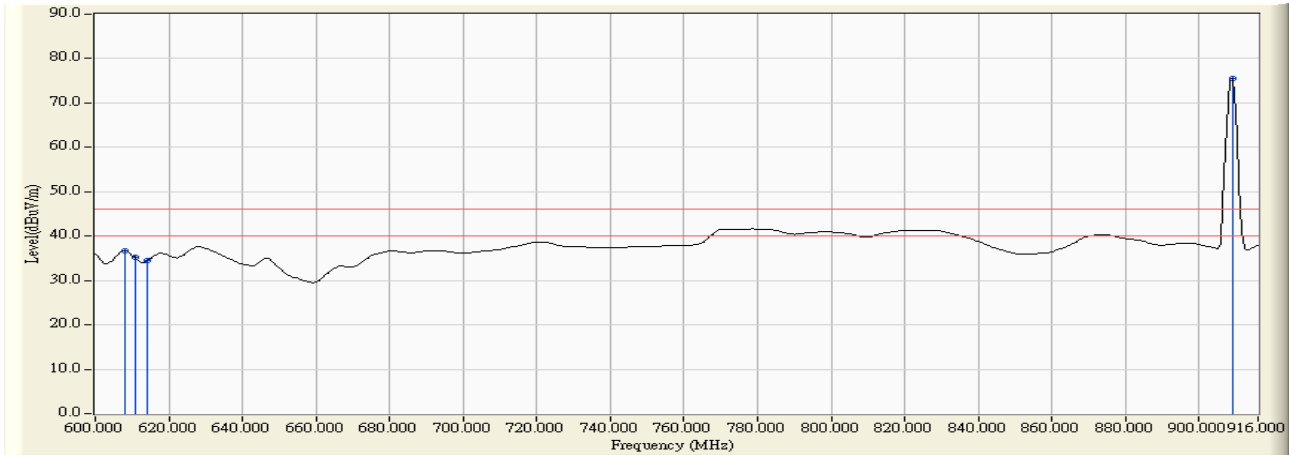

	Frequency (MHz)	Correct Factor (dB)	Reading Level (dBuV)	Measure Level (dBuV/m)	Margin (dB)	Peak Limit (dBuV/m)	Average Limit (dBuV/m)	Detector Type
1	608.000	23.369	13.334	36.703	-9.317	74.000	54.00	AVERAGE
2	* 610.766	21.762	13.403	35.165	-10.855	74.000	54.00	AVERAGE
3	614.000	20.961	13.465	34.426	-11.594	74.000	54.00	AVERAGE
4	909.034	22.404	53.041	75.445	29.425	74.000	54.00	AVERAGE

Note:

1. All Readings below 1GHz are Quasi-Peak, above are performed with peak and/or average measurements as necessary.
2. “ * ”, means this data is the worst emission level.
3. Measurement Level = Reading Level + Correct Factor.
4. The average measurement was not performed when the peak measured data under the limit of average detection. If the readings given are average, peak measurement should also be supplied.

Site : Site 1	Time : 2007/10/29 - 20:31
Limit : FCC_SpartC_15.209_03M_PK	Margin : 6
EUT : Control Point 1000	Probe : FCC_RF_1G-18G(2007) - HORIZONTAL
Power : AC 120V/60Hz	Note : Mode 1: Transmit (Adapter: OHE) Bandedge

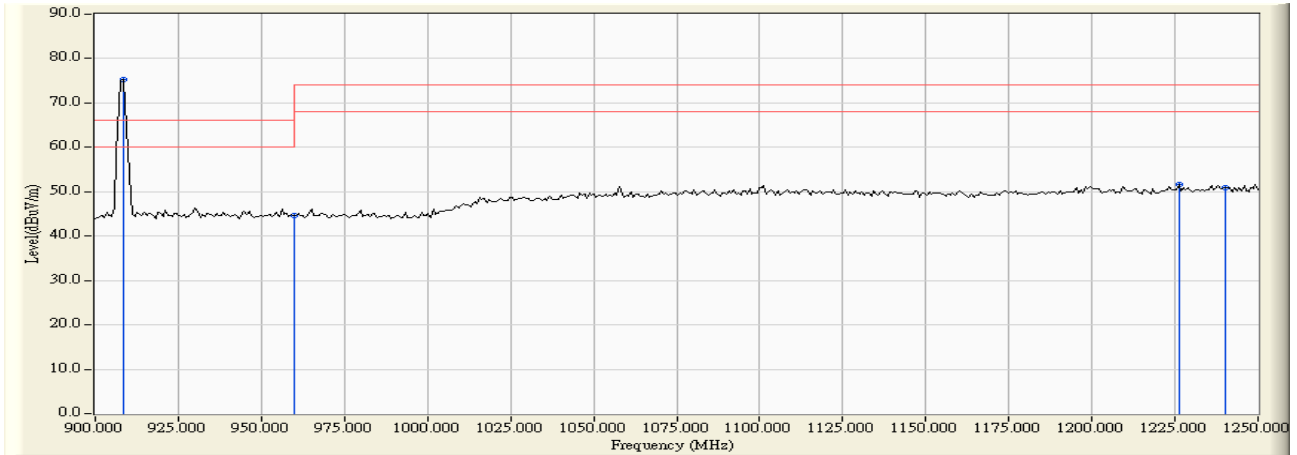

	Frequency (MHz)	Correct Factor (dB)	Reading Level (dBuV)	Measure Level (dBuV/m)	Margin (dB)	Peak Limit (dBuV/m)	Average Limit (dBuV/m)	Detector Type
1	908.417	17.910	57.267	75.177	9.157	74.000	54.00	PEAK
2	960.000	17.910	26.727	44.637	-21.383	74.000	54.00	PEAK
3	* 1226.152	22.050	29.575	51.625	-22.345	74.000	54.00	PEAK
4	1240.000	22.304	28.538	50.843	-23.127	74.000	54.00	PEAK

Note:

1. All Readings below 1GHz are Quasi-Peak, above are performed with peak and/or average measurements as necessary.
2. “ * ”, means this data is the worst emission level.
3. Measurement Level = Reading Level + Correct Factor.
4. The average measurement was not performed when the peak measured data under the limit of average detection. If the readings given are average, peak measurement should also be supplied.

Site : Site 1	Time : 2007/10/29 - 20:48
Limit : FCC_SpartC_15.209_03M_PK	Margin : 6
EUT : Control Point 1000	Probe : FCC_RF_1G-18G(2007) - VERTICAL
Power : AC 120V/60Hz	Note : Mode 1: Transmit (Adapter: OHE) Bandedge

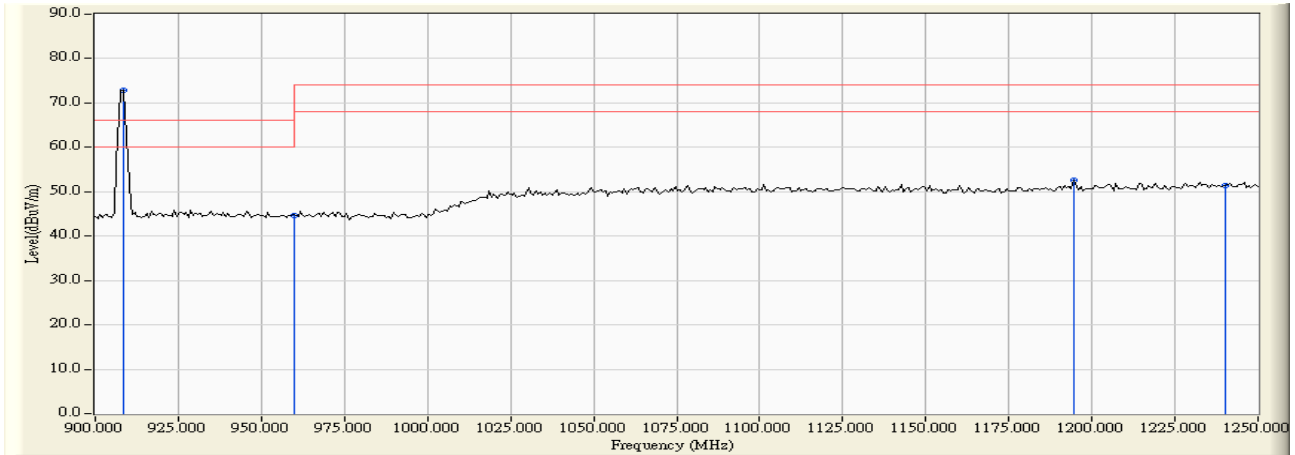

	Frequency (MHz)	Correct Factor (dB)	Reading Level (dBuV)	Measure Level (dBuV/m)	Margin (dB)	Peak Limit (dBuV/m)	Average Limit (dBuV/m)	Detector Type
1	908.417	17.910	54.918	72.828	6.808	74.000	54.00	PEAK
2	960.000	17.910	26.723	44.633	-21.387	74.000	54.00	PEAK
3	* 1194.589	23.093	29.486	52.579	-21.391	74.000	54.00	PEAK
4	1240.000	23.104	28.286	51.391	-22.579	74.000	54.00	PEAK

Note:

1. All Readings below 1GHz are Quasi-Peak, above are performed with peak and/or average measurements as necessary.
2. “ * ”, means this data is the worst emission level.
3. Measurement Level = Reading Level + Correct Factor.
4. The average measurement was not performed when the peak measured data under the limit of average detection. If the readings given are average, peak measurement should also be supplied.

Site : Site 1	Time : 2007/10/29 - 20:39
Limit : FCC_SpartC_15.209_03M_AV	Margin : 6
EUT : Control Point 1000	Probe : FCC_RF_1G-18G(2007) - HORIZONTAL
Power : AC 120V/60Hz	Note : Mode 1: Transmit (Adapter: OHE) Bandedge

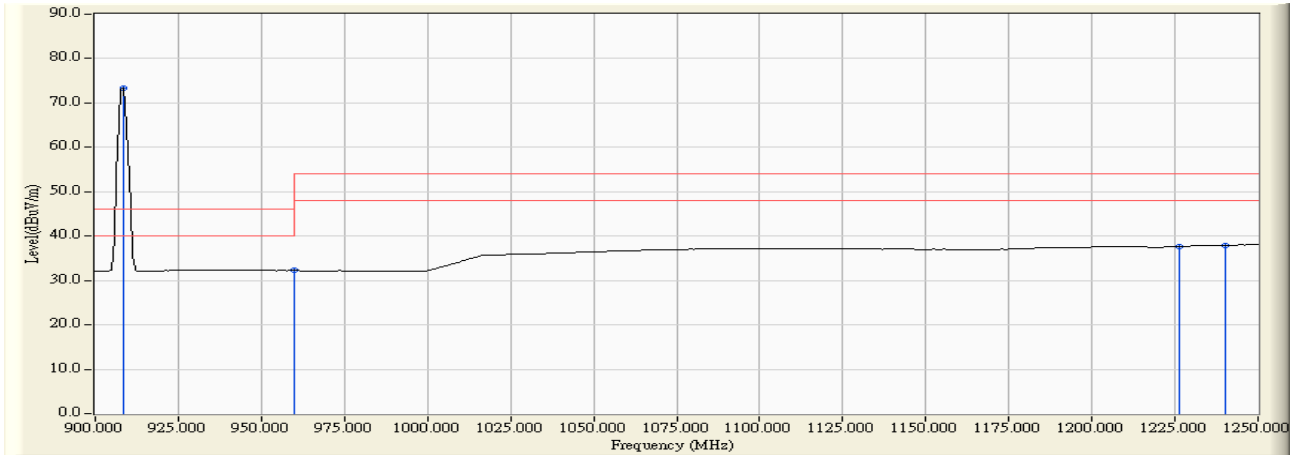

	Frequency (MHz)	Correct Factor (dB)	Reading Level (dBuV)	Measure Level (dBuV/m)	Margin (dB)	Peak Limit (dBuV/m)	Average Limit (dBuV/m)	Detector Type
1	908.417	17.910	55.398	73.308	27.288	74.000	54.00	AVERAGE
2	960.000	17.910	14.338	32.248	-13.772	74.000	54.00	AVERAGE
3	* 1226.152	22.050	15.628	37.678	-16.292	74.000	54.00	AVERAGE
4	1240.000	22.304	15.646	37.951	-16.019	74.000	54.00	AVERAGE

Note:

1. All Readings below 1GHz are Quasi-Peak, above are performed with peak and/or average measurements as necessary.
2. “ * ”, means this data is the worst emission level.
3. Measurement Level = Reading Level + Correct Factor.
4. The average measurement was not performed when the peak measured data under the limit of average detection. If the readings given are average, peak measurement should also be supplied.

Site : Site 1	Time : 2007/10/29 - 20:51
Limit : FCC_SpartC_15.209_03M_AV	Margin : 6
EUT : Control Point 1000	Probe : FCC_RF_1G-18G(2007) - VERTICAL
Power : AC 120V/60Hz	Note : Mode 1: Transmit (Adapter: OHE) Bandedge

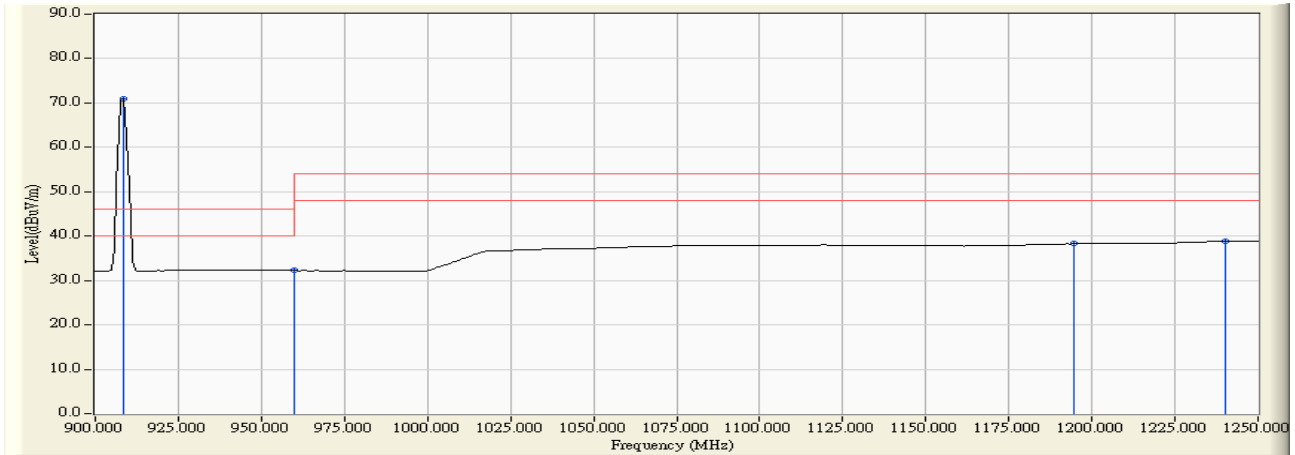

	Frequency (MHz)	Correct Factor (dB)	Reading Level (dBuV)	Measure Level (dBuV/m)	Margin (dB)	Peak Limit (dBuV/m)	Average Limit (dBuV/m)	Detector Type
1	908.417	17.910	53.053	70.963	24.943	46.020	54.00	AVERAGE
2	960.000	17.910	14.318	32.228	-13.792	46.020	54.00	AVERAGE
3	* 1194.589	23.093	15.164	38.257	-15.713	53.970	54.00	AVERAGE
4	1240.000	23.104	15.670	38.775	-15.195	53.970	54.00	AVERAGE

Note:

1. All Readings below 1GHz are Quasi-Peak, above are performed with peak and/or average measurements as necessary.
2. “ * ”, means this data is the worst emission level.
3. Measurement Level = Reading Level + Correct Factor.
4. The average measurement was not performed when the peak measured data under the limit of average detection. If the readings given are average, peak measurement should also be supplied.