

Two plated mounting holes are near rear panel.

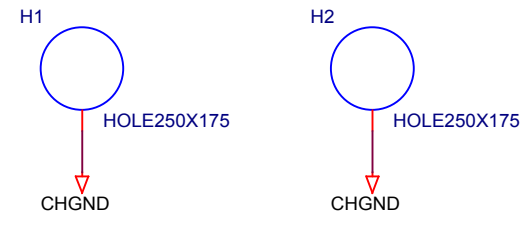

4Home Media, Inc. Saratoga, CA COMPANY CONFIDENTIAL		
Title 4Home C.P. - +12V DC Input		
Size B	Document Number <Doc>	Rev 2.0
Date:	Saturday, December 16, 2006	Sheet 1 of 8

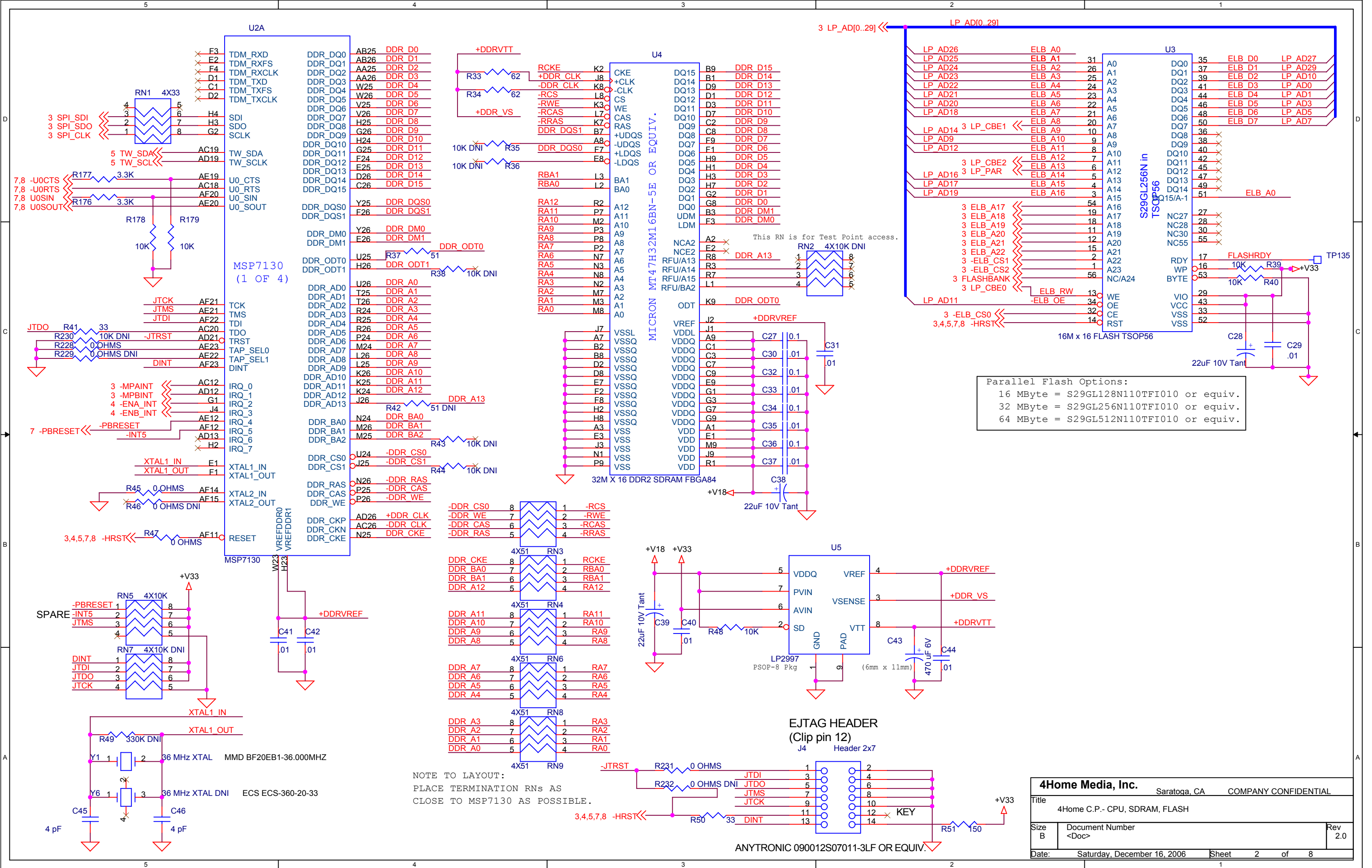

4Home Media, Inc.		Saratoga, CA	COMPANY CONFIDENTIAL
Title: 4Home C.P.- CPU, SDRAM, FLASH			
Size B	Document Number <Doc>	Rev 2.0	
Date:	Saturday, December 16, 2006	Sheet	2 of 8

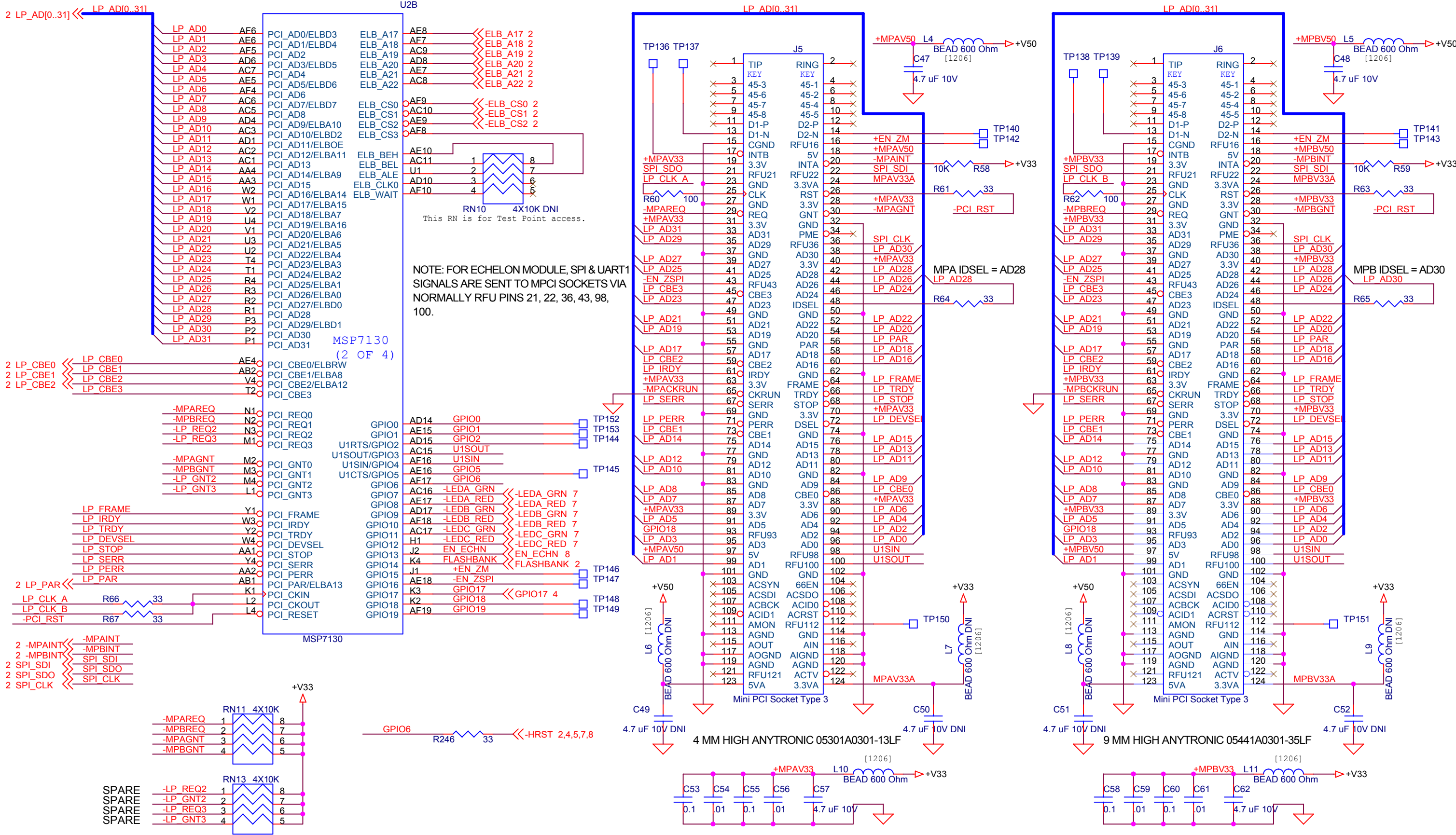

NOTE: FOR ECHELON MODULE, SPI & UART1 SIGNALS ARE SENT TO MPC1 SOCKETS VIA NORMALLY RFU PINS 21, 22, 36, 43, 98, 100.

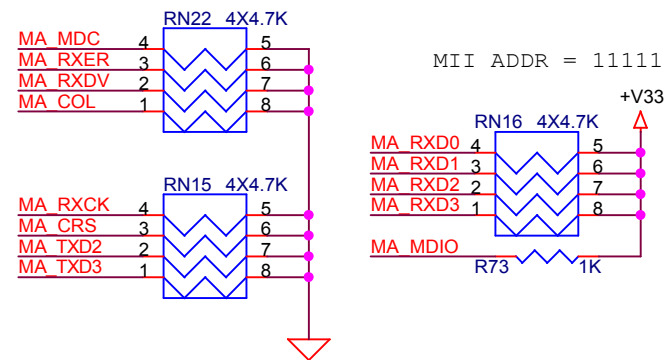

Note to Layout:
Observe special rules for these DM & DP traces.

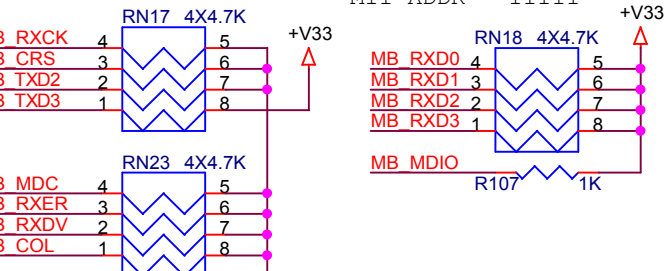
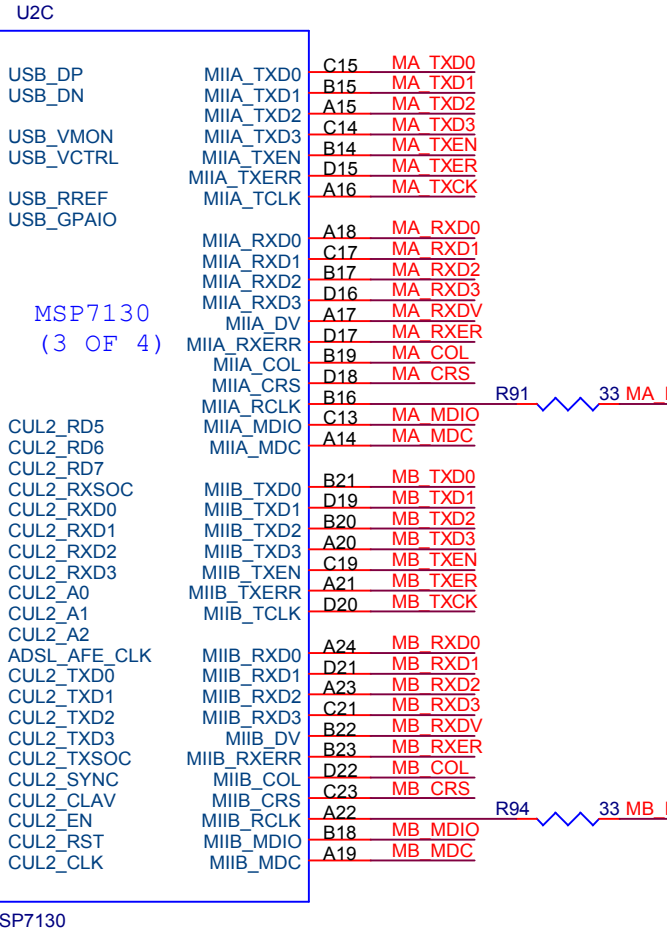

No Repeater Mode
8-bit Boot Flash
Single XTAL Mode

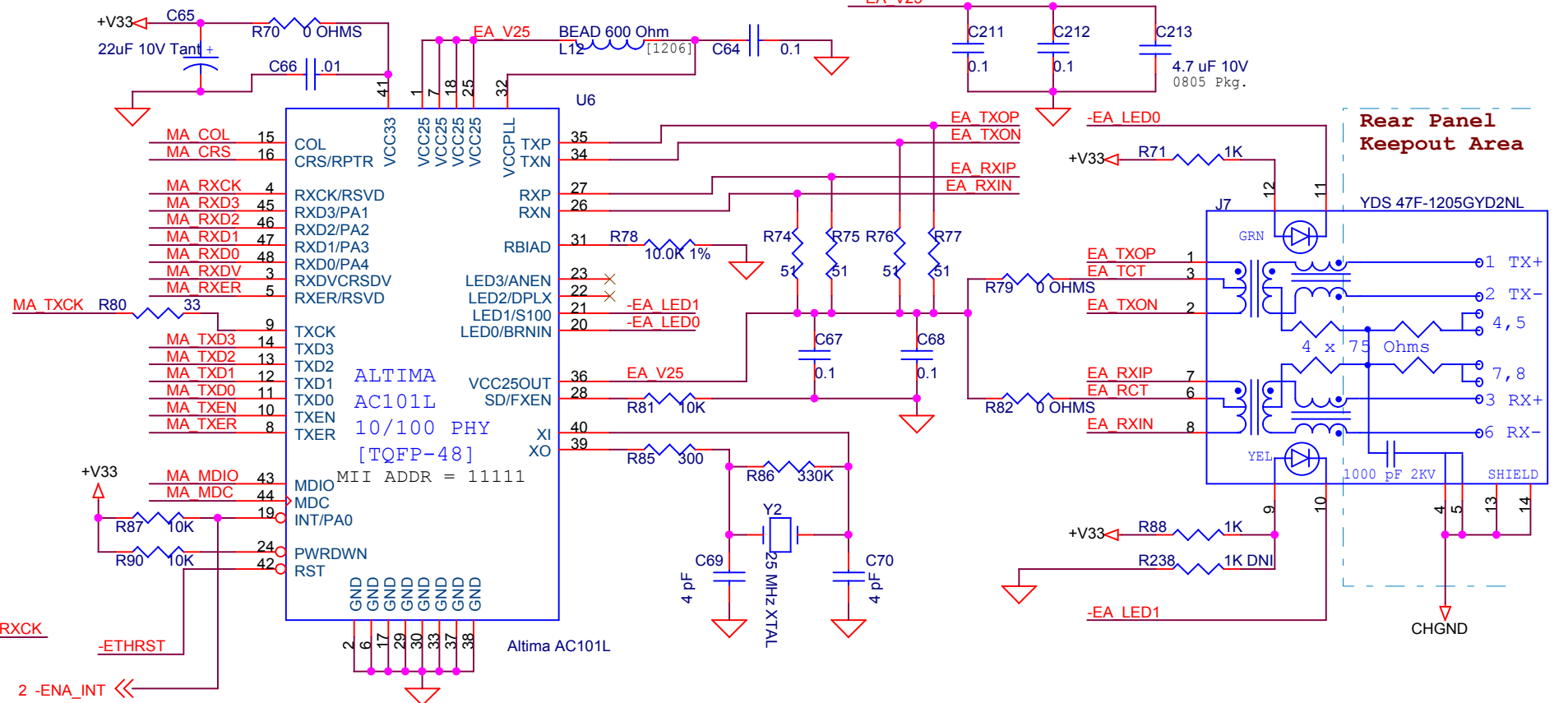

Rear Panel
Keepout Area

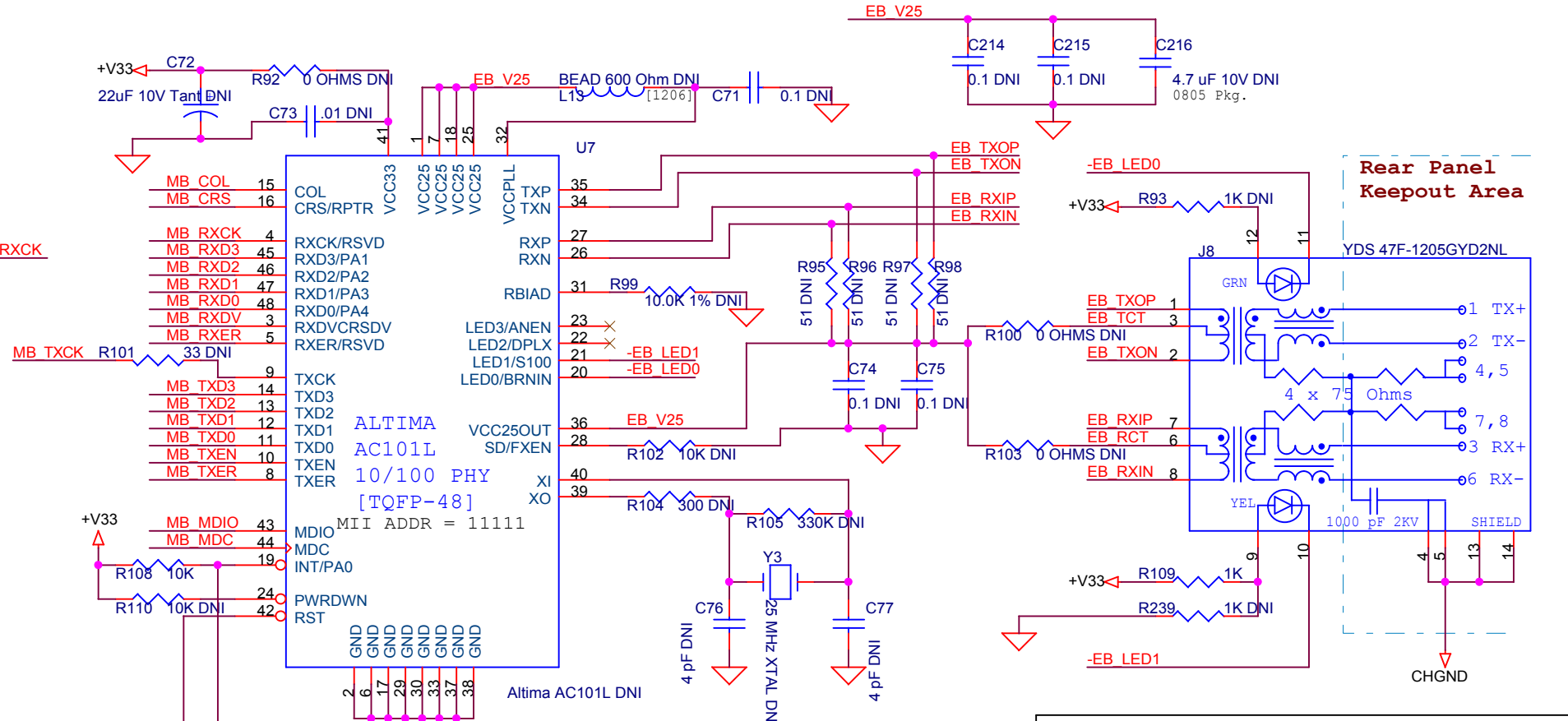

Rear Panel
Keepout Area

4Home Media, Inc. Saratoga, CA COMPANY CONFIDENTIAL		
Title: 4Home C.P. - 10/100 Ports		
Size: B	Document Number: <Doc>	Rev: 2.0
Date: Saturday, December 16, 2006	Sheet: 4	of 8