

FCC PART 15.247
EMI MEASUREMENT AND TEST REPORT
For

FULL RIVER (HONGKONG) LIMITED

BL3 Liantangjiao Industrial Zone ,Shima Village,Tangxia Town, Dongguan city ,China

FCC ID: VTIWL8185-PA

Nov.20,2007

This Report Concerns: Original Report	Equipment Type : WIRELESS LAN CARD
Test Engineer:	Eric Li <i>Eric Li</i>
Report No.:	F07111531C
Receive EUT Date/Test Date:	Nov. 14,2007/ Nov. 14-20,2007
Reviewed By:	Christina <i>Christina</i>
Prepared By:	 Shenzhen BST Technology Co.,Ltd. 3F,Weames Technology Building, No. 10 Kefa Road,Science Park, Nanshan District,Shenzhen,Guangdong,China Tel: 0755-26747751 ~ 3 Fax: 0755-26747751 ~ 3 ext.826

Note: The test report is specially limited to the above company and this particular sample only. It may not be duplicated without prior written consent of Shenzhen BST Technology Co.,Ltd. This report must not be used by the client to claim product certification,approval,or endorsement by NVLAP, NIST or any agency of the US Government.

TABLE OF CONTENTS

1.	GENERAL INFORMATION	4
1.1.	Report information	4
1.2.	Measurement Uncertainty	4
2.	PRODUCT DESCRIPTION	5
2.1.	EUT Description	5
2.2.	Block Diagram of EUT Configuration.....	5
2.3.	Support Equipment List	5
2.4.	Test Conditions	5
3.	FCC ID LABEL.....	6
4.	TEST RESULTS SUMMARY	7
	Modifications	7
5.	TEST EQUIPMENT USED	8
6.	CONDUCTED POWER LINE TEST.....	9
6.1.	Test Equipment	9
6.2.	Test Procedure	9
6.3.	Test Setup.....	9
6.4.	Configuring of the EUT	9
6.5.	EUT Operating Condition.....	11
6.6.	Conducted Power line Emission Limits.....	11
6.7.	Conducted Power Line Test Result.....	11
7.	RADIATED DISTURBANCE TEST	12
7.1.	Test Equipment	12
7.2.	Test Procedure	12
7.3.	Radiated Test Setup	12
7.4.	Configuration of the EUT	12
7.5.	EUT Operating Condition.....	12
7.6.	Radiated Emission Limit.....	12
7.7.	Radiated Emission Test Result	13
8.	6DB BANDWIDTH MEASUREMENT	17
8.1.	LIMITS OF 6dB BANDWIDTH MEASUREMENT.....	17
8.2.	Test Procedure	17
8.3.	Test Setup.....	17
8.4.	Test Data	17
9.	MAXIMUM PEAK OUTPUT POWER	18
9.1.	LIMITS OF MAXIMUM PEAK OUTPUT POWER MEASUREMENT	18
9.2.	TEST PROCEDURES	18
9.3.	Radiated Test Setup	18
9.4.	Test Data	18
10.	POWER SPECTRAL DENSITY MEASUREMENT.....	19
10.1.	LIMITS OF POWER SPECTRAL DENSITY MEASUREMENT.....	19

- 10.2. Test Procedure 19
- 10.3. TEST SETUP 19
- 10.4. Test Data 19
- 11. BAND EDGES MEASUREMENT20**
 - 11.1. LIMITS OF BAND EDGES MEASUREMENT..... 20
 - 11.2. TEST PROCEDURE 20
 - 11.3. TEST RESULTS 20
- 12. ANTENNA REQUIREMENT23**
 - 12.1. STANDARD APPLICABLE..... 23
 - 12.2. ANTENNA CONNECTED CONSTRUCTION 23
- APPENDIX I TEST CURVES.....24**
- APPENDIX II TEST PICTURE.....27**

1. GENERAL INFORMATION

1.1. Report information

1.1.1.This report is not a certificate of quality; it only applies to the sample of the specific product/equipment given at the time of its testing. The results are not used to indicate or imply that they are application to the similar items. In addition, such results must not be used to indicate or imply that BST approves recommends or endorses the manufacture, supplier or use of such product/equipment, or that BST in any way guarantees the later performance of the product/equipment.

1.1.2.The sample/s mentioned in this report is/are supplied by Applicant, BST therefore assumes no responsibility for the accuracy of information on the brand name, model number, origin of manufacture or any information supplied.

Additional copies of the report are available to the Applicant at an additional fee. No third part can obtain a copy of this report through BST, unless the applicant has authorized BST in writing to do so.

Test Facility -

The open area test site used to collect the radiated data is located on the address of Shenzhen Academy of Metrology & Quality Inspection (FCC Registered Test Site Number: 97379) on

Longzhu Road, Nanshan , Shenzhen, Guangdong, China.

The Open Area Test Site is constructed and calibrated to meet the FCC requirements.

1.2. Measurement Uncertainty

Available upon request.

2. PRODUCT DESCRIPTION

2.1. EUT Description

Description : WIRELESS LAN CARD

Applicant : FULL RIVER (HONGKONG) LIMITED
 BL3 Liantangjiao Industrial Zone ,Shima
 Village,Tangxia Town, Dongguan city ,China

Model Number : WL8185-PA

Additional Information

Frequency : 2412-2462MHz

Power Supply : DC5V (Supplied by computer)

Maximum Range : N/A

Transmitter : -

Antenna

Current Consumption : N/A

2.2. Block Diagram of EUT Configuration

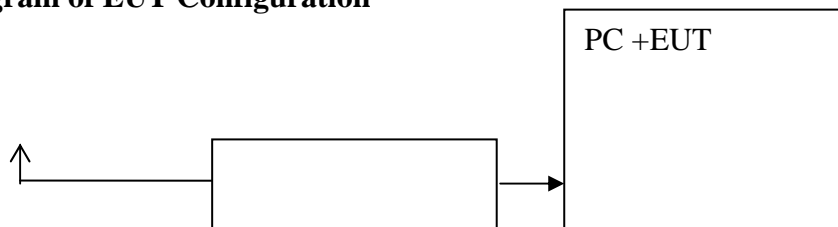

2.3. Support Equipment List

1. -----
2. PC(HP) FCC DOC
- 3.

2.4. Test Conditions

Temperature: 23~25

Relative Humidity: 55~63 %

3. FCC ID LABEL

FCC ID: VTIWL8185-PA

Label Location on EUT

EUT Bottom View/ FCC ID Label Location

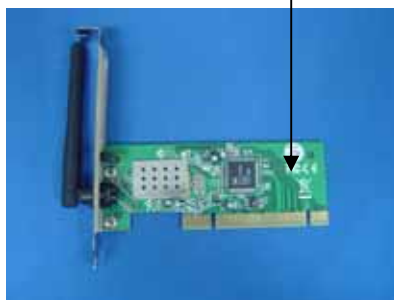

4. TEST RESULTS SUMMARY

FCC 15 Subpart C, Paragraph 15.247

Test Standards	Test Items	Test Results
FCC Part 15 Subpart C, Paragraph 15.247(d)	Radiated disturbance	Pass
FCC Part 15 Subpart C, Paragraph 15.247(a)(2)	Spectrum Bandwidth of a Direct Sequence Spread Spectrum System Limit: min. 500kHz	Pass
FCC Part 15 Subpart C, Paragraph 15.247(b)	Maximum Peak Output Power	Pass
FCC Part 15, Paragraph 15.247(e)	Power Spectral Density	Pass
FCC Part 15, Paragraph 15.247(d)	Band Edge Measurement Limit: 20dB less than the peak value of fundamental frequency	Pass
FCC Part 15, Paragraph 15.207	Conducted Test	Pass
FCC Part 15, Paragraph 15.203	Antenna Requirement	Pass

Remark: "N/A" means "Not applicable."

Modifications

No modification was made.

5. TEST EQUIPMENT USED

Equipment/Facilities	Manufacturer	Model #	Serial no.	Date of Cal.	Cal. Interval
Cable	Resenberger	N/A	NO.1	Mar 10 , 2007	1 Year
Cable	SCHWARZBECK	N/A	NO.2	Mar 10 , 2007	1 Year
Cable	SCHWARZBECK	N/A	NO.3	Mar 10 , 2007	1 Year
LISN	Rohde & Schwarz	ESH3-Z5	100305	Mar 10 , 2007	1 Year
50 Coaxial Switch	ANRITSU CORP	MP59B	6200283933	Mar 10, 2007	1 Year
EMI Test Receiver	Rohde & Schwarz	ESP13	100180	Oct.18,2007	1 Year
Spectrum Analyzer	Rohde & Schwarz	FSP40	100273	Sep.10,2007	1 Year
3m Semi-Anechoic Chamber	Albatross Projects	9m×6m×6m	N/A	Feb.20,2007	1 Year
Signal Generator	FLUKE	PM5418 + Y/C	LO747012	Feb.20,2007	1 Year
Signal Generator	FLUKE	PM5418TX	LO738007	Feb.20,2007	1 Year
Loop Antenna	SCHWARZBECK	FMZB1516	113	Jan.30,2007	1 Year
Trilog-Super Broadband Antenna	SCHWARZBECK	VULB9161	9161-4079	Sep.22,2007	1 Year
Broad-Band Horn Antenna	SCHWARZBECK	BBHA9120D	9120D-564	Sep.22,2007	1 Year
Ultra Broadband Antenna	Rohde & Schwarz	HL-562	100110	June.15,2007	1 Year
AMN	Rohde & Schwarz	ESH3-Z5	100196	Oct.11,2007	1 Year
AMN	Rohde & Schwarz	ESH3-Z5	100197	Oct.11,2007	1 Year
Pulse Limiter	Rohde & Schwarz	ESH3-Z2	N/A	N/A	N/A
Power Meter	Rohde & Schwarz	NRVD	100041	Feb.20,2007	1 Year
EMI Test Receiver	Rohde & Schwarz	ESCS30	100003	Feb.20,2007	1 Year
Coaxial Cable with N-connectors	SCHWARZBECK	AK9515H	95549	Sep.22,2007	1 Year
Radio Communication Test Set	Rohde & Schwarz	CMS 54	846621/024	Feb.20,2007	1 Year
Modulation Analyzer	Hewlett-Packard	8901B	2303A00362	Feb.20,2007	1 Year
Absorbing clamp	Rohde & Schwarz	MDS-21	N/A	Oct.29,2007	1 Year

6. CONDUCTED POWER LINE TEST

6.1. Test Equipment

Please refer to section 5 this report.

6.2. Test Procedure

The EUT and simulators are connected to the main power through a line impedance stabilization network (L.I.S.N.).This provides a 50ohm/50uh coupling inpedance for the measuring equipment.The peripheral devices are also connected to the main power through a LISN that provides a 50ohm/50uh coupling inpedance with 50ohm termination.

Both sides of A.C. Line are check for maximum conducted interference.In order to find the maximum emission,the relative positions of equipment and all of the interface cables must be changed according to ASIN C63.4:2003 on conducted measurement .Conducted emissions were invested over the frequency range from 0.15MHz to 30MH z using a receiver bandwidth of 9Khz.

6.3. Test Setup

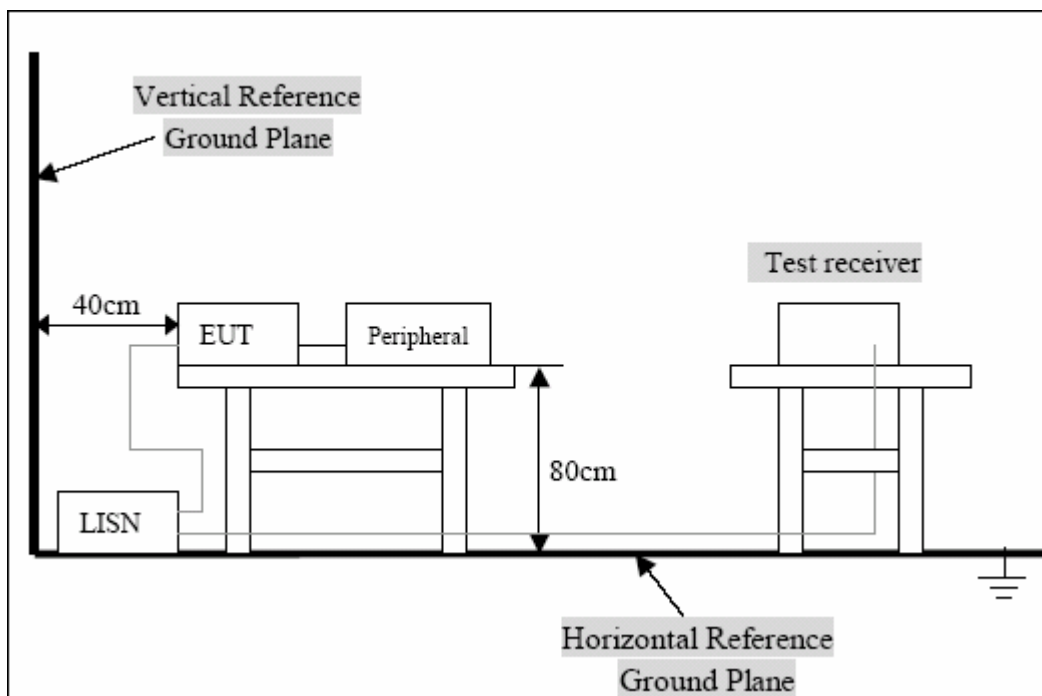

For the actual test configuration,Please refer to the related items-Photos of testing

6.4. Configuring of the EUT

The EUT was configured according to ASIN C63.4:4-2003. EUT was used DC 5.0V (Power by PC). The operation frequency is from 13.56MHZ. Enable the signal transmitted from the external antenna from EUT to receiver. All interface ports were connected to the appropriate peripherals. All peripherals and cables are listed below.

A.EUT

Device	Manufacturer	Model #	FCC ID
Refer to Section 2			

B.Internal Devices

Device	Manufacturer	# Model	FCC ID
N/A			

6.5. EUT Operating Condition

Operating condition is according to ANSI C63.4-2003.
 Setup the EUT and simulators as shown on follow.
 Enable RF signal and confirm EUT active.
 Modulate output capacity of EUT up to specification.

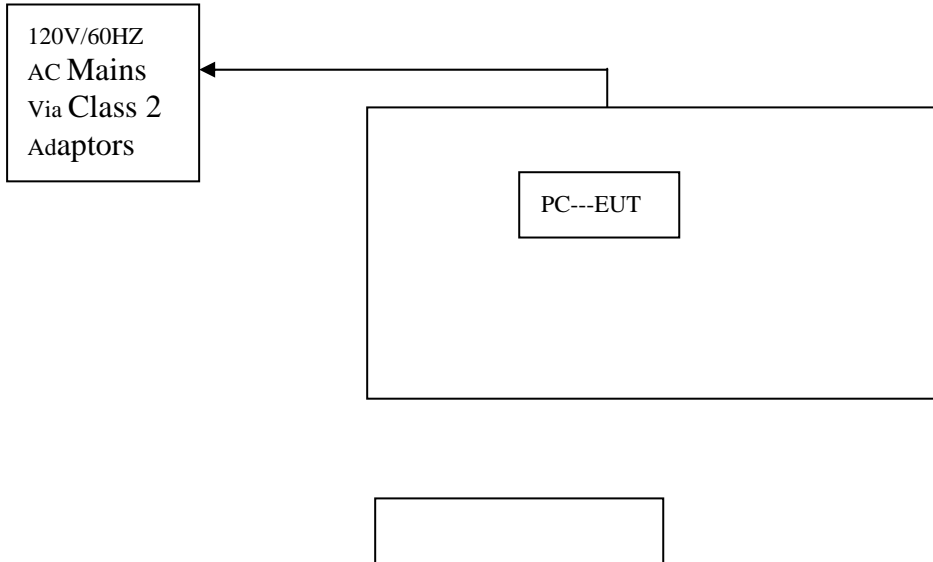

6.6. Conducted Power line Emission Limits

FCC Part 15 Paragraph 15.207 (dBuv)			
Range	Frequency (MHZ)	Class A QP/AV	Class B QP/AV
	0.15-0.5	79/66	65-56/56-46
	0.5-5.0	73/60	56-46
	5.0-3.0	73/60	60-50

Note: In the above table, the tighter limit applies at the band edges.

6.7. Conducted Power Line Test Result

Refer to APPENDIX I Test Curves

7. RADIATED DISTURBANCE TEST

7.1. Test Equipment

Please refer to section 5 this report.

7.2. Test Procedure

The out of band emission tests were performed in the 3-meter chamber test site, using the setup accordance with the ANSI C63.4-2003. The specification used was the FCC Part Subpart C limits.

7.3. Radiated Test Setup

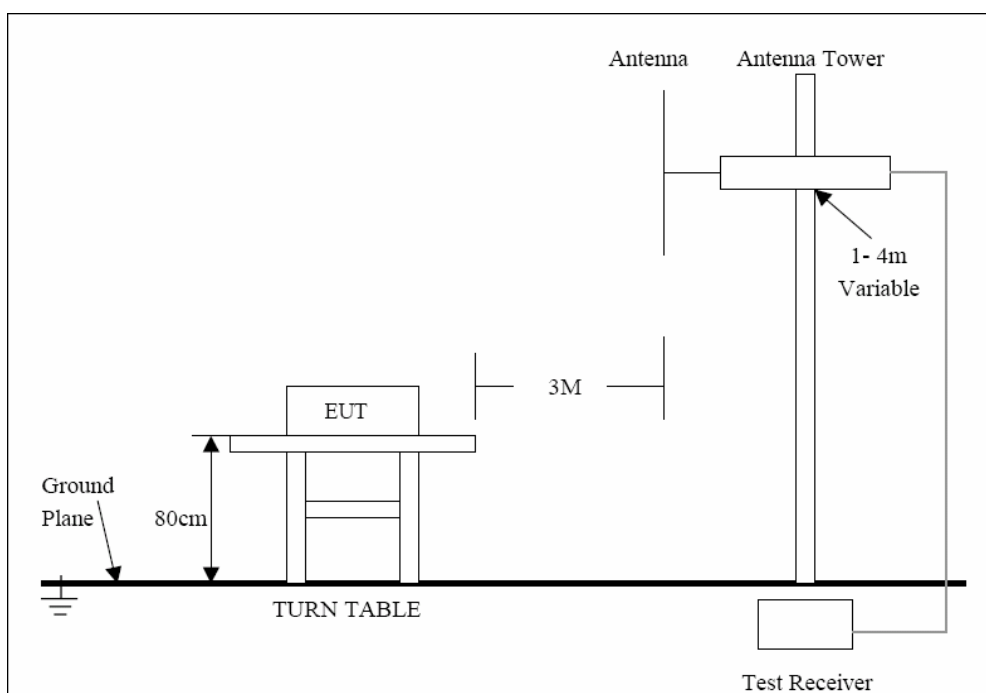

Setup below 3mMHz, refer to 7.3; For the accrual test configuration, please refer to the related items-photos of Testing.

7.4. Configuration of the EUT

Same as section 6.4 of this report

7.5. EUT Operating Condition

Same as section 6.5 of this report.

7.6. Radiated Emission Limit

radiator shall not exceed the field strength levels specified in the following table:

Frequency (MHZ)	Distance (m)	Field Strength (microvolts/m)
Fundamental	-	50000
Harmonics	-	500
30-88	3	100
88-216	3	150
216-960	3	200
ABOVE 960	3	500

7.7. Radiated Emission Test Result

General Radiated Emission Data

Below 1GHz Worst-Case Data

Ambient temperature: 24° C Relative humidity: 53 % Test mode: (ch6 2437MHz)						
Frequency MHz	Emission QP (dBuV/m)	Read Value (dBuV)	Correction Factor (dB/m)	Polarization	Limits (dBuV/m)	Note
121.352	35.4	23.5	11.9	Horizontal	43.5	---
151.579	28.6	17.7	10.9	Horizontal	43.5	---
214.179	32.6	18.3	14.3	Horizontal	43.5	---
284.120	37.0	17.0	20.0	Horizontal	46.0	---
498.303	32.2	12.2	20.0	Horizontal	46.0	---
914.892	36.6	16.0	20.6	Horizontal	46.0	---
32.821	35.8	28.0	7.8	Vertical	40.0	---
121.355	30.1	16.9	13.2	Vertical	43.5	---
154.082	27.1	13.8	13.3	Vertical	43.5	---
216.352	24.3	12.4	11.9	Vertical	43.5	---
278.016	28.6	17.0	11.6	Vertical	46.0	---
424.308	32.9	13.8	19.1	Vertical	46.0	---
568.156	35.9	15.3	20.6	Vertical	46.0	---
913.601	35.0	12.7	22.3	Vertical	46.0	---

- REMARKS:** 1. Emission level(dBuV/m)=Read Value(dBuV) + Correction Factor(dB/m)
 2. Correction Factor(dB/m) = Antenna Factor (dB/m) + Cable Factor (dB)
 3. The other emission levels were very low against the limit.

Emission Up 1GHz

Radiated Emission Data

Ambient temperature: 24° C						
Relative humidity: 53 %						
Test mode: (ch1 2412MHz)						
Frequency MHz	Emission (dBuV/m)	Read Value (dBuV)	Correction Factor (dB/m)	Polarization	Limits (dBuV/m)	Note
2412.0	116.50	117.7	-1.2	Vertical		Fundamental(PK)
2412.0	103.40	104.6	-1.2	Horizontal		Fundamental(PK)
7206.0	56.10	46.1	10	Horizontal	74.0	Harmonic (PK)
4824.0	56.30	50.0	6.3	Horizontal	74.0	Harmonic(PK)
4824.0	58.40	52.1	6.3	Vertical	74.0	Harmonic(PK)
7206.0	59.20	49.2	10	Vertical	74.0	Harmonic(PK)
2412.0	89.70	90.9	-1.2	Vertical		Fundamental (AV)
2412.0	84.30	85.5	-1.2	Horizontal		Fundamental (AV)
4824.0	49.10	42.8	6.3	Horizontal	54.0	Harmonic(AV)
7602.0	49.20	39.2	10	Horizontal	54.0	Harmonic(AV)
4824.0	51.80	45.5	6.3	Vertical	54.0	Harmonic(AV)
7206.0	53.30	43.3	10	Vertical	54.0	Harmonic(AV)

- REMARKS:** 1. Emission level(dBuV/m)=Read Value(dBuV) + Correction Factor(dB/m)
 2. Correction Factor(dB/m) = Antenna Factor (dB/m) + Cable Factor (dB)+Amplifier Factor(dB)
 3. The other emission levels were very low against the lim

Radiated Emission Data

Ambient temperature: 24° C						
Relative humidity: 53 %						
Test mode: (ch6 2437MHz)						
Frequency GHz	Emission (dBuV/m)	Read Value (dBuV)	Correction Factor (dB/m)	Polarization	Limits (dBuV/m)	Note
Frequency GHz	90.7	94.6	-3.9	Horizontal		Fundamental(PK)
2437.0	119.60	120.8	-1.2	Vertical		Fundamental(PK)
2437.0	108.40	109.6	-1.2	Horizontal		Fundamental(PK)
7311.0	55.60	45.6	10	Horizontal	74.0	Harmonic (PK)
4874.0	57.30	51.0	6.3	Horizontal	74.0	Harmonic (PK)
4874.0	59.40	53.1	6.3	Vertical	74.0	Harmonic(PK)
7311.0	61.10	51.1	10	Vertical	74.0	Harmonic(PK)
2437.0	89.90	91.1	-1.2	Vertical		Fundamental (AV)
2437.0	86.70	87.9	-1.2	Horizontal		Fundamental (AV)
4874.0	50.60	44.3	6.3	Horizontal	54.0	Harmonic(AV)
7311.0	51.20	41.2	10	Horizontal	54.0	Harmonic(AV)
4874.0	53.00	46.7	6.3	Vertical	54.0	Harmonic(AV)
7311.0	53.60	43.6	10	Vertical	54.0	Harmonic(AV)

- REMARKS:** 1. Emission level(dBuV/m)=Read Value(dBuV) + Correction Factor(dB/m)
 2. Correction Factor(dB/m) = Antenna Factor (dB/m) + Cable Factor (dB)+Amplifier Factor(dB)
 3. The other emission levels were very low against the limit.

Radiated Emission Data

Ambient temperature: 24° C
 Relative humidity: 53 %
 Test mode: (ch11 2462MHz)

Frequency GHz	Emission (dBuV/m)	Read Value (dBuV)	Correction Factor (dB/m)	Polarization	Limits (dBuV/m)	Note
2462.0	98.40	99.6	-1.2	Vertical		Fundamental(PK)
2462.0	108.60	109.8	-1.2	Horizontal		Fundamental(PK)
4924.0	55.40	49.1	6.3	Horizontal	74.0	Harmonic (PK)
7386.0	58.20	48.2	10	Horizontal	74.0	Harmonic (PK)
4924.0	59.30	53.0	6.3	Vertical	74.0	Harmonic(PK)
7386.0	59.90	49.9	10	Vertical	74.0	Harmonic(PK)
2462.0	87.90	89.1	-1.2	Vertical		Fundamental (AV)
2462.0	79.60	80.8	-1.2	Horizontal		Fundamental (AV)
4924.0	48.00	41.7	6.3	Horizontal	54.0	Harmonic(AV)
7386.0	50.90	40.9	10	Horizontal	54.0	Harmonic(AV)
4924.0	52.80	46.5	6.3	Vertical	54.0	Harmonic(AV)
7386.0	53.40	43.4	10	Vertical	54.0	Harmonic(AV)

- REMARKS:** 1. Emission level(dBuV/m)=Read Value(dBuV) + Correction Factor(dB/m)
 2. Correction Factor(dB/m) = Antenna Factor (dB/m) + Cable Factor (dB)+Amplifier Factor(dB)
 3. The other emission levels were very low against the limit.

8. 6DB BANDWIDTH MEASUREMENT

8.1. LIMITS OF 6dB BANDWIDTH MEASUREMENT

The minimum of 6dB Bandwidth Measurement is 0.5 MHz.

8.2. Test Procedure

The transmitter output was connected to the spectrum analyzer through an attenuator. The bandwidth of the fundamental frequency was measured by spectrum analyzer with 100kHz RBW and 100kHz VBW. The 6dB bandwidth is defined as the total spectrum the power of which is higher than peak power minus 6dB.

8.3. Test Setup



8.4. Test Data

Test Data

CHANNEL	6dB BANDWIDTH (MHz)	MINIMUM LIMIT (MHz)	results
Ch1 , 2412MHz	11.97	0.5	Pass
Ch6 , 2437MHz	12.64	0.5	Pass
Ch11 , 2462MHz	12.77	0.5	Pass

9. MAXIMUM PEAK OUTPUT POWER

9.1. LIMITS OF MAXIMUM PEAK OUTPUT POWER MEASUREMENT

The Maximum Peak Output Power Measurement is 30dBm.

9.2. TEST PROCEDURES

1. A detector was used on the output port of the EUT. An oscilloscope was used to read the response of the detector.
2. Replaced the EUT by the signal generator. The center frequency of the S.G was adjusted to the center frequency of the measured channel.
3. Adjusted the power to have the same reading on oscilloscope. Record the power level.

9.3. Radiated Test Setup

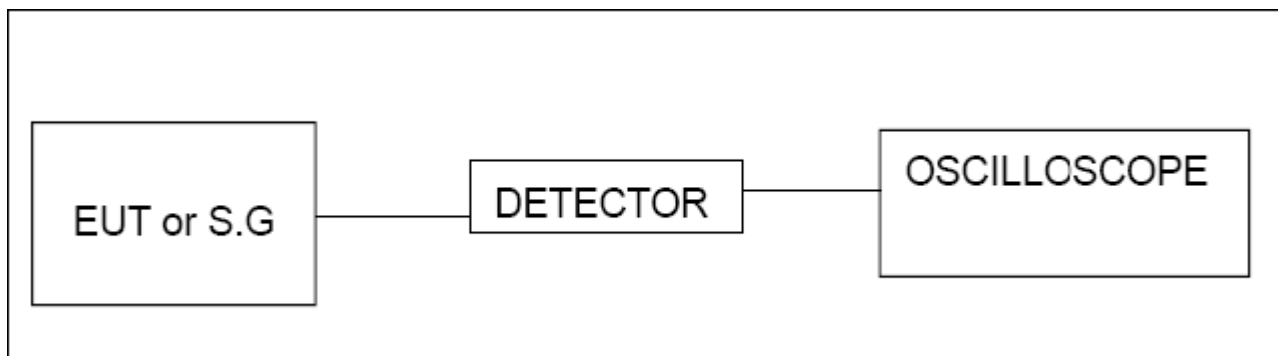

9.4. Test Data

Test Data

CHANNEL	Peak Power Output (dBm)	LIMIT (dBm)	results
Ch1	16.1	30dBm	Pass
Ch6	16.7	30dBm	Pass
Ch11	15.9	30dBm	Pass

Note : The power was integrated over 26 dB bandwidth.

10. POWER SPECTRAL DENSITY MEASUREMENT

10.1.LIMITS OF POWER SPECTRAL DENSITY MEASUREMENT

The Maximum of Power Spectral Density Measurement is 8dBm.

10.2.Test Procedure

The transmitter output was connected to the spectrum analyzer through an attenuator, the bandwidth of the fundamental frequency was measured with the spectrum analyzer using 3kHz RBW and 30kHz VBW, set sweep time = span/3kHz.

The power spectral density was measured and recorded.

The sweep time is allowed to be longer than span/3kHz for a full response of the mixer in the spectrum analyzer.

10.3. TEST SETUP

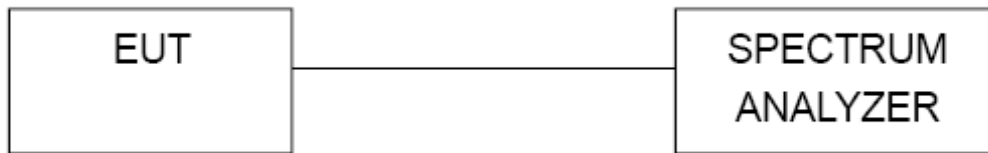

10.4.Test Data

Test Data

CHANNEL	RF POWER LEVEL IN 3kHz BW (dBm)	MAXIMUM LIMIT (dBm)	results
Ch1	-18.1	8	Pass
Ch6	-17.88	8	Pass
Ch11	-18.23	8	Pass

11. BAND EDGES MEASUREMENT

11.1.LIMITS OF BAND EDGES MEASUREMENT

Below -20dB of the highest emission level of operating band (in 100kHz Resolution Bandwidth).

11.2.TEST PROCEDURE

The transmitter output was connected to the spectrum analyzer via a low lose cable. Set both RBW and VBW of spectrum analyzer to 100kHz with suitable frequency span including 100 MHz bandwidth from band edge. The band edges was measured and recorded.

The spectrum plots (Peak RBW=VBW=100kHz) are attached on the following pages.

11.3.TEST RESULTS

The spectrum plots are attached on the following images.

- a) Lower Band Edge: maximum value is -29.34dBm that is attenuated more than 20dB
- b) Upper Band Edge: maximum value is -44.32dBm that is attenuated more than 20dB

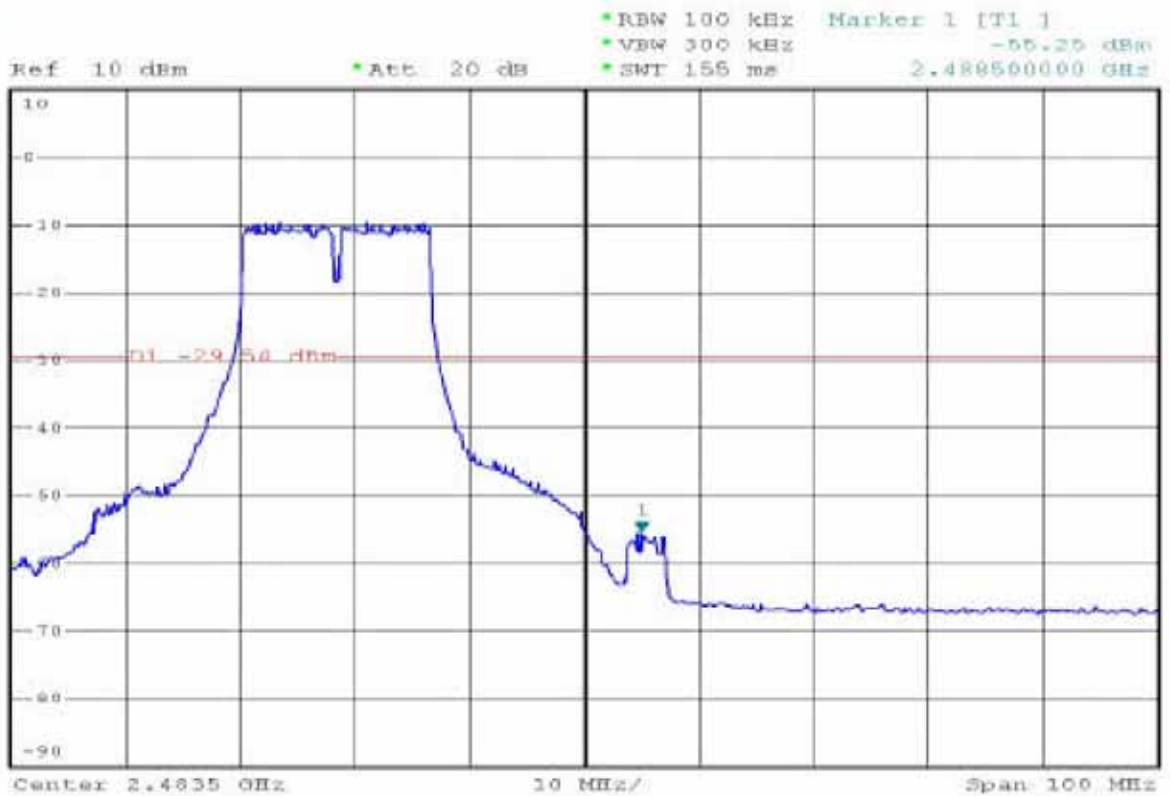
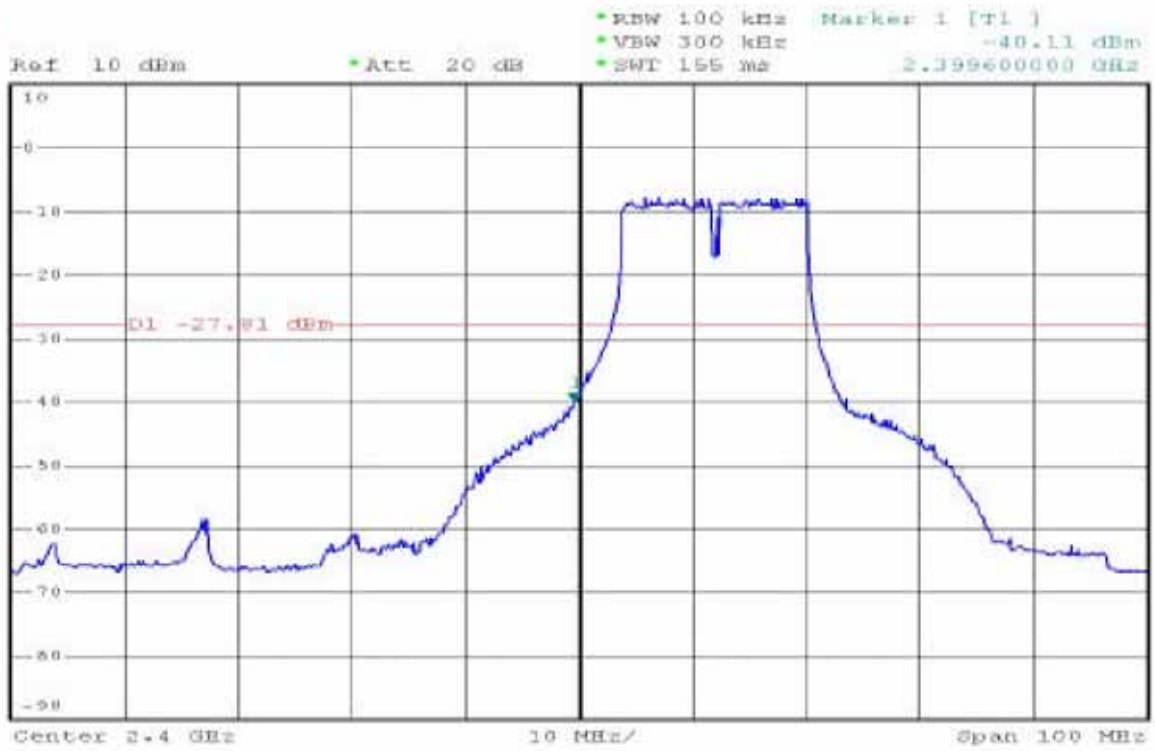

NOTE:

15.205:Emission in 2310 – 2390 MHz and 2483.5 to 2500 MHz (restricted band)

All readings above 1 GHz are AV and PK values. RBW=1MHz and VBW=10Hz for AV value ,

RBW=1MHz and VBW RBW for peak value.Measurements were made at 3 meters

a) Channel 1

Fundamental Frequency: 2412 MHz

Frequency (MHz)	Level (dBuV)	Read Value (dBuV)	Correction Factor (dB/m)	Polarization	Remark	Margin (dB)	Limit@3m (dBuV/m)	
							Peak	Ave.
2355.288	37.76	38.96	-1.2	H	Avg.	37.81	74	54
2343.864	40.39	41.59	-1.2	V	Avg.	40.58	74	54
2390.000	--	--	-1.2	V	Avg.	49.09	74	54
2390.000	--	--	-1.2	H	Peak	52.39	74	54
2344.068	49.12	50.32	-1.2	H	Peak	--	74	54
2332.440	51.45	52.65	-1.2	V	Peak	--	74	54

b) Channel 11

Fundamental Frequency: 2462 MHz

Frequency (MHz)	Level (dBuV)	Read Value (dBuV)	Correction Factor (dB/m)	Polarization	Remark	Margin (dB)	Limit@3m (dBuV/m)	
							Peak	Ave.
2488.980	37.81	39.01	-1.2	H	Avg.	H	74	54
2486.548	40.58	41.78	-1.2	V	Avg.	V	74	54
2485.712	49.09	50.29	-1.2	H	Peak	H	74	54
2495.820	52.39	53.59	-1.2	V	Peak	V	74	54
2483.500	--	--	-1.2	H	Peak	H	74	54
2483.500	--	--	-1.2	V	Peak	V	74	54

Notes:

1. Level = Reading + Corrected Factor
2. Corrected Factor = Antenna Factor + Cable Loss – Amplifier, example:37.81 = 31.60 + 6.21
- 3.--:The emission is too low.

12. ANTENNA REQUIREMENT

12.1. STANDARD APPLICABLE

For intentional device, according to FCC 47 CFR Section 15.203, an intentional radiator shall be designed to ensure that no antenna other than that furnished by the responsible party shall be used with the device. And according to FCC 47 CFR Section 15.247 (b), if transmitting antennas of directional gain greater than 6dBi are used, the power shall be reduced by the amount in dB that the directional gain of the antenna exceeds 6dBi.

12.2.ANTENNA CONNECTED CONSTRUCTION

The antenna connector is unique,
The maximum
Gain of the antenna is 2.7dBi.

APPENDIX I TEST CURVES



RECEIVER FREQUENCY
402 kHz
Att 10 dB

RBW 9 kHz
MT 1 ms
PREAMP OFF

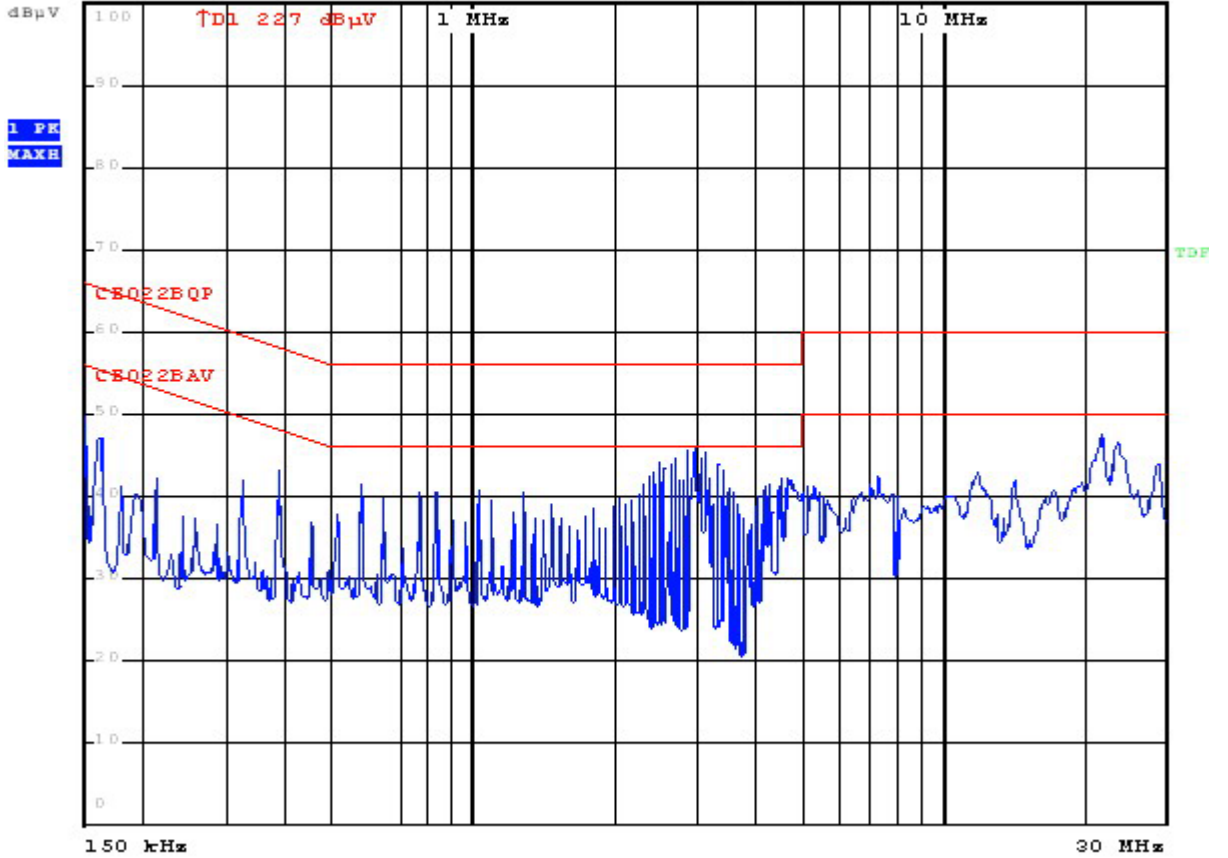



Demod FM

RBW 9 kHz
MT 100 ms
PREAMP OFF

Att 10 dB

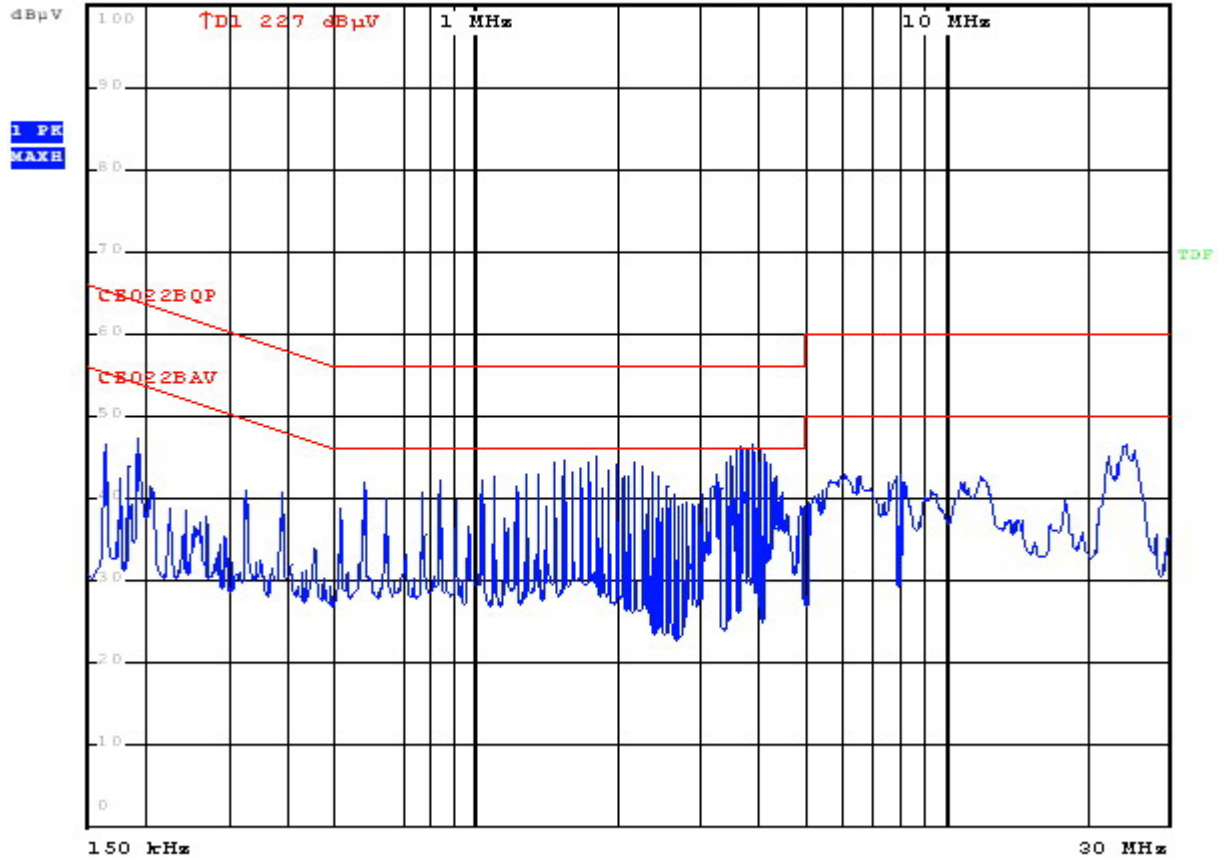

APPENDIX II TEST PICTURE

Photo 1 Conducted Disturbance Test



Photo 2 Radiated disturbances



Photo 3 General Appearance of the EUT



Photo 4 General Appearance of the EUT

