

▶ PSENmlock mini PSEN mIm 1 sa 1.1/2.1/2.2

PILZ
THE SPIRIT OF SAFETY

Operating Manual-1005802-EN-02-Draft
- PSEN sensor technology



Draft

This document is the original document.

Where unavoidable, for reasons of readability, the masculine form has been selected when formulating this document. We do assure you that all persons are regarded without discrimination and on an equal basis.

All rights to this documentation are reserved by Pilz GmbH & Co. KG. Copies may be made for the user's internal purposes. Suggestions and comments for improving this documentation will be gratefully received.

Pilz®, PIT®, PMI®, PNOZ®, Primo®, PSEN®, PSS®, PVIS®, SafetyBUS p®, SafetyEYE®, SafetyNET p®, the spirit of safety® are registered and protected trademarks of Pilz GmbH & Co. KG in some countries.



SD means Secure Digital

1	Introduction	5
1.1	Validity of documentation	5
1.2	Using the documentation	5
1.3	Definition of symbols	5
1.4	Third-party manufacturer licence information	6
2	Safety	7
2.1	Intended use	7
2.2	Safety regulations	8
2.2.1	Safety assessment	8
2.2.2	Additional documents that apply	8
2.2.3	Use of qualified personnel	8
2.2.4	Warranty and liability	9
2.2.5	Disposal	9
2.3	For your safety	9
3	Security	10
4	Overview	11
4.1	Device features	11
4.2	Approved combinations	12
5	Function description	13
5.1	Structure	13
5.2	Safety outputs 12 and 22	15
5.3	Safety inputs S11 and S21 (series connection)	16
5.4	Diagnostic output/signal output Y32	16
5.5	Diagnostic input Y1	16
5.6	Activation of safety inputs S31 and S41 (solenoid operation)	16
5.7	Safety Device Diagnostics	18
5.8	Operating modes	20
5.8.1	Operation without Safety Device Diagnostics	21
5.8.1.1	Timing diagram, case 1 (operation without Safety Device Diagnostics)	21
5.8.1.2	Timing diagram, case 2 (automatic guard locking when closing the safety gate)	22
5.8.2	Operation with active use of Safety Diagnostics	23
5.9	Block diagram	24
5.10	Auxiliary release	25
5.10.1	Recommissioning	26
6	Wiring	28
6.1	Important information	28
6.2	Pin assignment, connector and cable	28
6.3	EMC requirements and electrical safety	29
7	Connection to control systems and evaluation devices	30
7.1	Important information	30
7.2	Minimum requirements for activation of guard locking	31
7.3	Single connection	33

7.4	Series connection.....	33
7.5	Connection to Pilz evaluation devices.....	38
8	Teaching in the actuator	39
9	Installation	41
9.1	Important information	41
9.2	Align safety switch and actuator.....	42
9.3	Installation of multiple safety switches	43
9.4	PSEN mlm mounting types	44
9.4.1	External attachment with actuator a.....	44
9.4.1.1	Installation on sliding gate.....	44
9.4.1.2	Installation on swing gate.....	44
9.4.2	Internal attachment with actuator b.....	48
9.5	Installation safety switch	50
9.5.1	Mounting of safety switch using two screws	51
9.6	Actuator installation	52
9.7	Internal attachment: Mounting of safety switch and actuator using mounting set 1 (optional).....	52
9.7.1	Mounting guidelines for internally attached auxiliary release.....	55
10	Operation	56
10.1	PSEN mlm in normal operation.....	56
10.2	Fault indicator PSEN mlm.....	58
11	Checks and maintenance	59
12	Dimensions	61
13	Technical details	63
14	Classification in accordance with ZVEI, CB24I	71
15	Safety characteristic data	72
16	Supplementary data	73
16.1	Radio approval.....	73
17	Order reference	74
17.1	System.....	74
17.2	Accessories.....	75
18	EC declaration of conformity	78
19	EC declaration of conformity	79
20	UKCA-Declaration of Conformity	80

1 Introduction

1.1 Validity of documentation

This operating manual explains the function and operation, describes the installation and provides guidelines on how to connect the product.

This documentation is valid for the product PSEN mIm 1 sa 1.1/2.1/2.2.

1.2 Using the documentation

This document is intended for instruction. Only install and commission the product if you have read and understood this document. The document should be retained for future reference.

1.3 Definition of symbols

Information that is particularly important is identified as follows:



DANGER!

This warning must be heeded! It warns of a hazardous situation that poses an immediate threat of serious injury and death and indicates preventive measures that can be taken.



WARNING!

This warning must be heeded! It warns of a hazardous situation that could lead to serious injury and death and indicates preventive measures that can be taken.



CAUTION!

This refers to a hazard that can lead to a less serious or minor injury plus material damage, and also provides information on preventive measures that can be taken.



NOTICE

This describes a situation in which the product or devices could be damaged and also provides information on preventive measures that can be taken. It also highlights areas within the text that are of particular importance.



INFORMATION

This gives advice on applications and provides information on special features.

1.4 **Third-party manufacturer licence information**

This product includes Open Source software with various licenses.

Further information is available in the document "Third-party manufacturer licence information PSEN mlm 1 ba/sa" (document number 1006757) at www.pilz.com.

Draft

2 Safety



INFORMATION

If the auxiliary release screw is not turned back correctly after use, guard locking cannot be activated/deactivated.

2.1 Intended use

PSENmlock mini is used for safe guard locking and safe interlocking on small swing gates and sliding gates, as well as flaps and covers. It prevents a safeguard from being opened while a hazardous machine function is being performed.

The hazardous machine function may only be executed under the following conditions:

- ▶ There is a high signal at safety outputs 12 and 22 and
- ▶ There is a low signal at safety inputs S31 (Lock/Unlock Request 1) and S41 (Lock/Unlock Request 2).

Safety inputs S31 and S41 (solenoid operation) may only be operated under the following condition:

- ▶ Plant is in a safe condition

Make sure that this is the case with an AND operation in the safety system immediately before the output is operated.

The safety switch meets the requirements in accordance with:

- ▶ EN 60947-5-3: PDDb
- ▶ EN ISO 13849-1: PL d (Cat. 3)
- ▶ EN ISO 14119
 - Interlocking device with guard locking
 - Coding level with actuator PSEN mlm 1 sa 1.1: low, type 4
 - Coding level with actuator PSEN mlm 1 sa 2.1/2.2: high, type 4

The safety switch may only be used with one of the approved actuators (see [Approved combinations](#) [12]). Only mounting aids provided by Pilz may be used to make the attachment.

Safety level PL d (Cat. 3) is only achieved when

- ▶ For the interlock, the safety outputs have 2-channel processing
- ▶ For guard locking, the solenoid has 2-channel operation via safe, tested outputs, suitable for PL d (Cat. 3) applications.

With 1-channel operation of the safety inputs S31 (Lock/Unlock Request 1) and S41 (Lock/Unlock Request 2), it is only possible to achieve safety level PL d (Cat. 2).

The following is deemed improper use in particular

- ▶ Any component, technical or electrical modification to the product,
- ▶ Use of the product outside the areas described in this operating manual,
 - Use under corrosive environmental conditions (cooling emulsions, surface treatment, gases, ...),

- Use in environments with high dust pollution,
- ▶ Use of the safety switch and actuator as mechanical stops,
- ▶ Use of the product outside the technical details (see [Technical details](#)  63]).

2.2 Safety regulations

2.2.1 Safety assessment

Before using a device, a safety assessment in accordance with the Machinery Directive is required.

As an individual component, the product meets functional safety requirements in accordance with EN ISO 13849. However, this does not guarantee the functional safety of the overall plant/machine. To achieve the relevant safety level of the overall plant/machine's required safety functions, each safety function needs to be considered separately.

The safety switch does not have an emergency release.

2.2.2 Additional documents that apply

Please read and take note of the following documents.

Only when using Safety Device Diagnostics (SDD)

- ▶ Fieldbus module operating manual, for example SDD ES PROFINET
- ▶ System description "Safety Device Diagnostics"

When using passive junctions

- ▶ Operating manual for a passive junction

When using a series connection

- ▶ PSEN System Description, safety switch series connection (10065003)

You will need to be conversant with the information in these documents in order to fully understand this operating manual.

2.2.3 Use of qualified personnel

The products may only be assembled, installed, programmed, commissioned, operated, maintained and decommissioned by persons who are competent to do so.

A competent person is a qualified and knowledgeable person who, because of their training, experience and current professional activity, has the specialist knowledge required. In order to inspect, assess and handle products, devices, systems, plant and machinery, this person must be familiar with the state of the art and the applicable national, European and international laws, directives and standards.

It is the company's responsibility only to employ personnel who

- ▶ Are familiar with the basic regulations concerning health and safety / accident prevention,
- ▶ Have read and understood the information provided in the section entitled Safety
- ▶ Have a good knowledge of the generic and specialist standards applicable to the specific application.

2.2.4 Warranty and liability

All claims to warranty and liability will be rendered invalid if

- ▶ The product was used contrary to the purpose for which it is intended,
- ▶ Damage can be attributed to not having followed the guidelines in the manual,
- ▶ Operating personnel are not suitably qualified,
- ▶ Any type of modification has been made (e.g. exchanging components on the PCB boards, soldering work etc.).

2.2.5 Disposal

- ▶ In safety-related applications, please comply with the mission time T_M in the safety-related characteristic data.
- ▶ When decommissioning, please comply with local regulations regarding the disposal of electronic devices (e.g. Electrical and Electronic Equipment Act).

2.3 For your safety



WARNING!

Risk of injury due to loss of the safety function

Replacing an actuator (e.g. defective actuator) with an inappropriate actuator from the interlock and guard locking system may lead to serious injury and death.

- You should prevent the interlocking and guard locking system from being manipulated with an inappropriate actuator.
- Keep the substitute actuator (optional) in a safe place and protect it from unauthorised access.
- Destroy any replaced actuators before disposal.

3 **Security**

To secure plants, systems, machines and networks against cyberthreats it is necessary to implement (and continuously maintain) an overall industrial security concept that is state of the art.

Perform a risk assessment in accordance with VDI/VDE 2182 or IEC 62443-3-2 and plan the security measures with care. If necessary, seek advice from Pilz Customer Support.

Draft

4 Overview

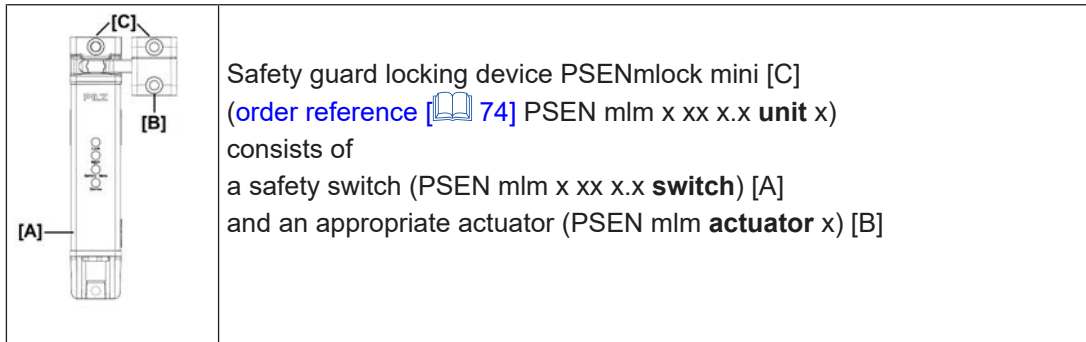

4.1 Device features

- ▶ Safe guard locking for small swing gates and sliding gates, as well as flaps and covers
- ▶ Safe interlocking (position monitoring)
- ▶ Transponder technology
- ▶ 2 safety outputs
- ▶ 2 safety outputs for the solenoids [Series connection \[33\]](#)
- ▶ 2 safety inputs to activate the solenoid
- ▶ 2 safety inputs for the [series connection \[33\]](#)
- ▶ Safety Device Diagnostics (SDD)
 - Safety Device Diagnostics can be used to retrieve sensor information on one or more sensors, to perform actions and to read and write configuration parameters.
 - Manipulation protection in accordance with ISO 14119 is possible by verifying the short name of the actuator through the controller via SDD communication
- ▶ Diagnostic input
- ▶ Signal output/diagnostic output
- ▶ Guard locking element keeps the safety gate from being opened unintentionally
- ▶ Auxiliary release for opening the safety gate
- ▶ Suitable for left and right hinged safety gates
- ▶ Pilz coding type
 Information about the Pilz coding types can be found under [Teaching in the actuator \[39\]](#).
 - PSEN mlm x sa 1.1: coded
 - PSEN mlm x sa 2.1: fully coded
 - PSEN mlm x sa 2.2: uniquely coded
- ▶ M12, 12-pin male connector
- ▶ LEDs:
 - Lock: Status of guard locking
 - Input: Status of safety inputs S11 and S21
 - Safety gate: Status of actuator
 - Device: Supply voltage/fault

- ▶ The actuator is available in two types (see [Order reference: Accessories \[75\]](#)).
 - Actuator a (side mounting, external attachment)
 - Actuator b (front mounting, internal attachment)

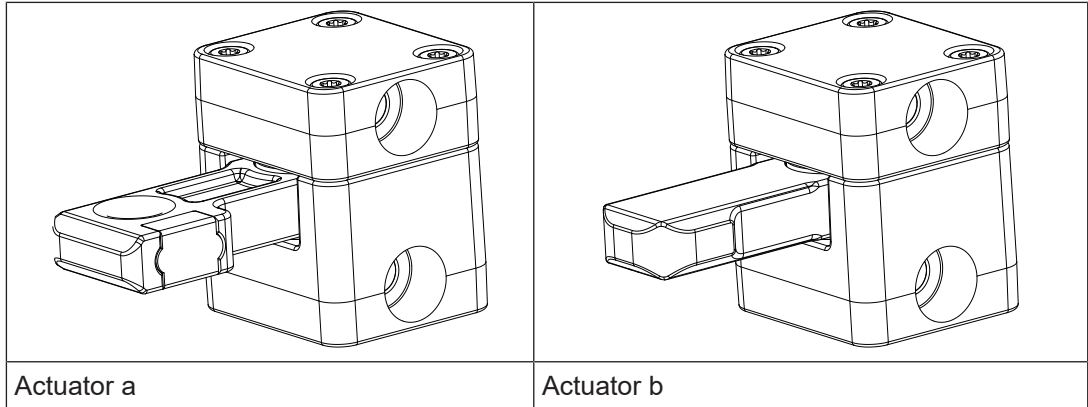

4.2

Approved combinations

An approved combination (unit) consists of a safety switch and the corresponding actuator. Information such as product type, features and order number, see [Order reference \[74\]](#).

PSEN mlm x sa 1.1

Safety switch	Actuator
PSEN mlm x sa 1.1 switch	PSEN mlm actuator a
	PSEN mlm actuator b

PSEN mlm x sa 2.x

Safety switch	Actuator
PSEN mlm x sa 2.1 switch	PSEN mlm actuator a
	PSEN mlm actuator b
PSEN mlm x sa 2.2 switch	PSEN mlm actuator a
	PSEN mlm actuator b

5 Function description

5.1 Structure

The interlocking and guard locking system prevents the safety gates to the danger zone from being opened while there is any hazard within the danger zone (machine movement, voltage, ...).

The safety outputs 12/22 may have a high or low signal, depending on the position of the actuator, the state of the safety inputs S31/S41 (solenoid activation) and the state of the safety inputs S11/S21.

Safety switch and actuator a, external attachment

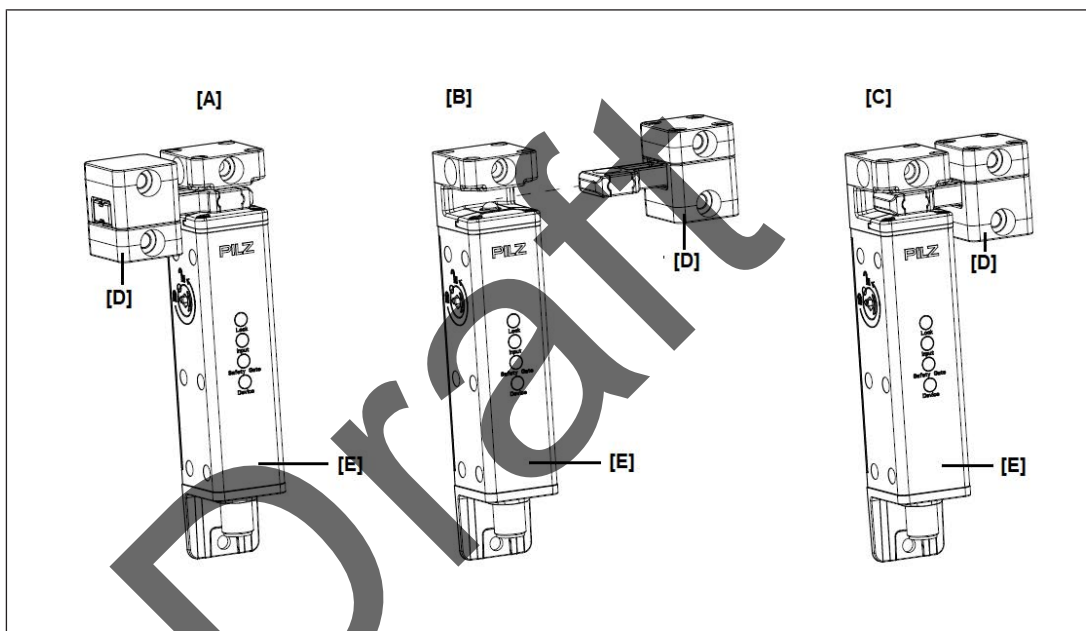

Legend

- [A] Safety switch and actuator **a** (right-hand side mounting, external attachment)
Gate closed
- [B] Safety switch and actuator **a** (left-hand side mounting, external attachment)
Gate open
- [C] Safety switch and actuator **a** (left-hand side mounting, external attachment)
Gate closed
- [D] Actuator **a**
- [E] Safety switch

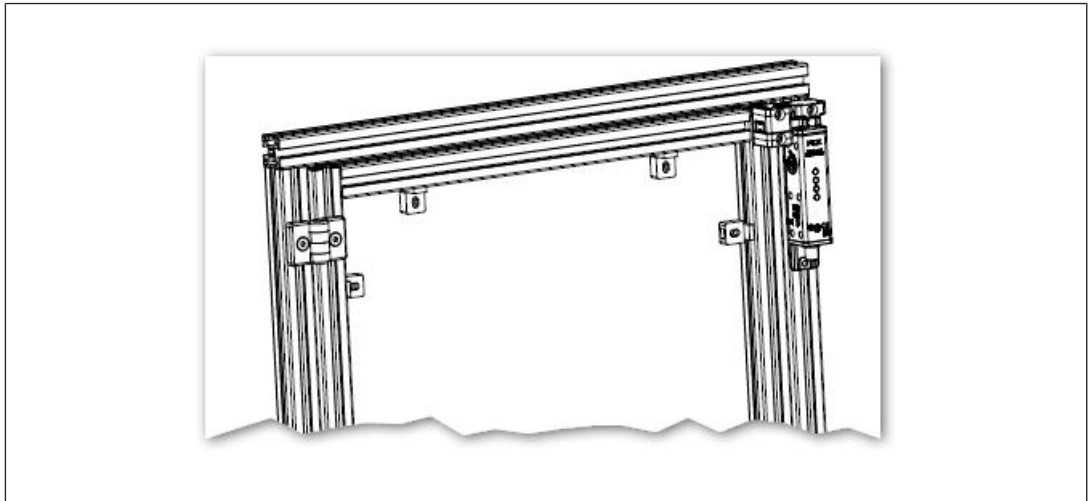
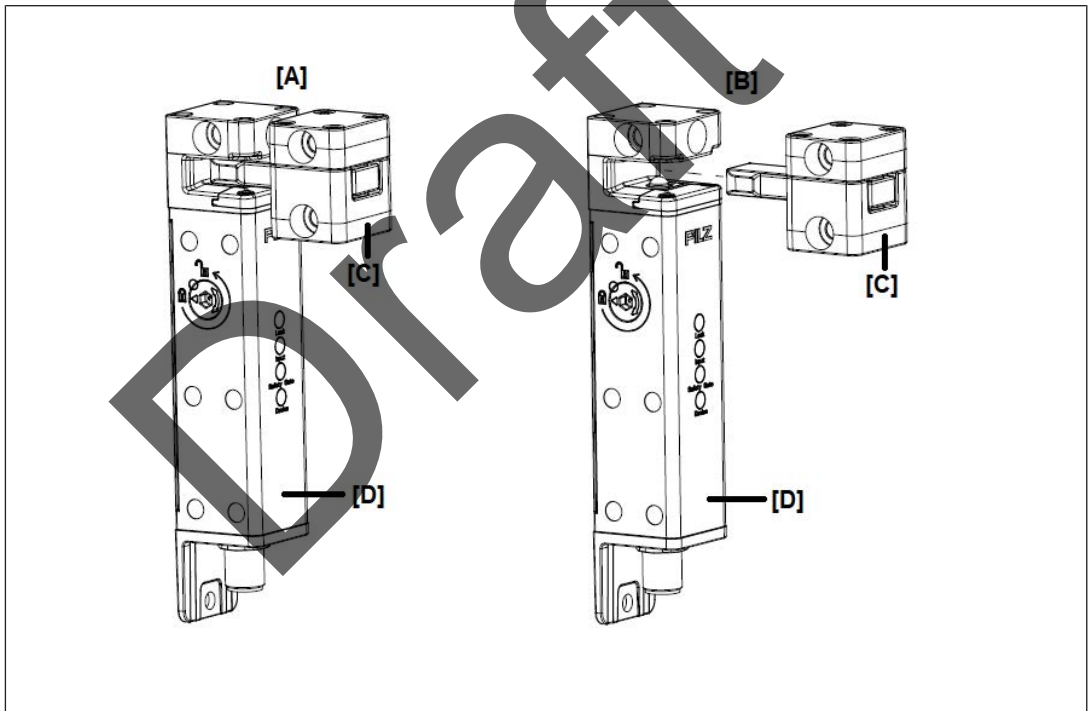

Fig.: Example: External attachment of safety switch and actuator a (left-hand side mounting)

Safety switch and actuator b, internal attachment



Legend

- [A] Safety switch and actuator **b** (front mounting, internal attachment)
Gate closed
- [B] Safety switch and actuator **b** (front mounting, internal attachment)
Gate open
- [C] Actuator **b**
- [D] Safety switch

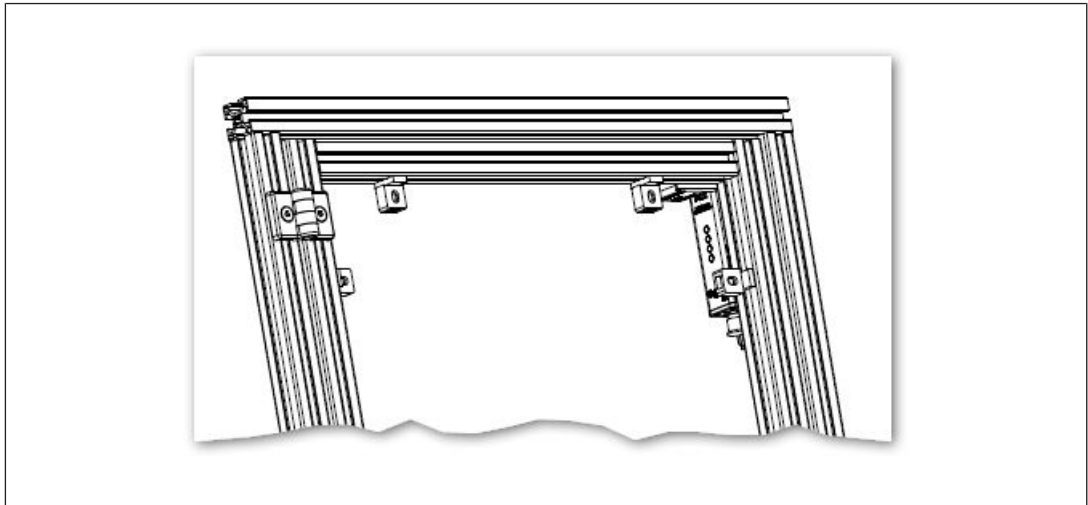

Fig.: Example: Internal attachment of safety switch and actuator b (view from the outside)

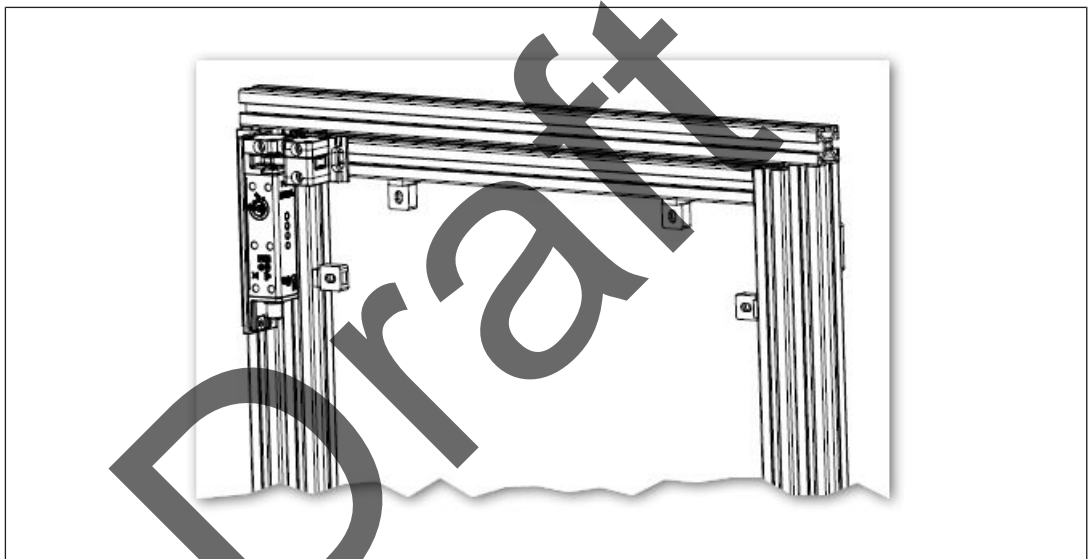

Fig.: Example: Internal attachment of safety switch and actuator b (view from the inside)

5.2 Safety outputs 12 and 22

Under these conditions there is a high signal at safety outputs 12 and 22:

- ▶ The actuator is detected **and**
- ▶ The guard locking pin has been activated successfully (guard locking pin is in the locked position) **and**
- ▶ There is a low signal at the safety inputs S31 and S41 **and**
- ▶ There is a high signal at the safety inputs S11 and S21

If one of these conditions is not met, the signal at the safety outputs will be low.

- ▶ If one safety input S11 or S21 switches from high to low, while the other safety input remains high, safety outputs 12/22 switch off (low) and the Input LED goes out.
- ▶ If this safety input switches back from low to high while the other safety input remains high, safety outputs 12/22 switch to high.

5.3 Safety inputs S11 and S21 (series connection)

The safety switch has safety inputs S11 und S21, enabling additional safety switches to be connected.

If safety input S11/S21 is switched off, safety output 12/22 is also switched off.

Safety outputs 12/22 are connected via safety inputs S11/S21, see [Series connection](#) [ 33].

5.4 Diagnostic output/signal output Y32

▶ Signal output/diagnostic output Y32 without SDD mode

- When the correct actuator has been detected (safety gate detected as closed), there is a high signal at signal output/diagnostic output Y32.

▶ Signal output/diagnostic output Y32 with SDD mode

- If an SDD fieldbus module is used, the signal output/diagnostic output Y32 is activated for writing data.

5.5 Diagnostic input Y1

If an SDD fieldbus module is used, the diagnostic input Y1 is automatically activated and data is read.

If no SDD fieldbus module is used, the diagnostic input Y1 must be connected to 24 V.

In a series connection, the signal output/diagnostic output Y32 must be connected to diagnostic input Y1 on the next sensor in the series connection, see [Series connection](#) [ 33].

5.6 Activation of safety inputs S31 and S41 (solenoid operation)

Guard locking

- ▶ Guard locking on the safety switch is activated/deactivated via the safety inputs S31 and S41.
- ▶ In the series connection, safety outputs 32/42 forward activation of the solenoid to the next safety switch.
- ▶ Guard locking can only be activated when the actuator provided for the safety switch is engaged (failsafe locking mechanism).
- ▶ Guard locking on the safety switch **is based on a bistable, electromechanical principle.**

If the power supply is interrupted, the guard locking device maintains the last position it had prior to the power interruption. This means:

- Guard locking remains deactivated, if it was deactivated prior to the power interruption
or
- Guard locking remains activated, if it was activated prior to the power interruption.

- ▶ Guard locking may only be deactivated by the higher level safety controller once the hazardous machine movement has been completed.

- ▶ In a fault state, guard locking can be deactivated when die "Lock" LED lights up green. It cannot be reactivated in the fault state.

Active use of Safety Device Diagnostics

- ▶ After activation of guard locking is received from the controller, the safety inputs S31 and S41 must have a low signal within [t1] max. 500 ms.

Single connection

Guard locking is activated by a low signal at the safety inputs S31 and S41. A high signal at these safety inputs deactivates guard locking (power to unlock).

Series connection

In a series connection with n safety switches, guard locking is activated by a low signal with the safety inputs S31/S41 (solenoid activation). Guard locking is activated and safety outputs 12/22 are switched on after a delay. Please refer to the technical details (see [Technical details \[63\]](#)) for the length of the delay.

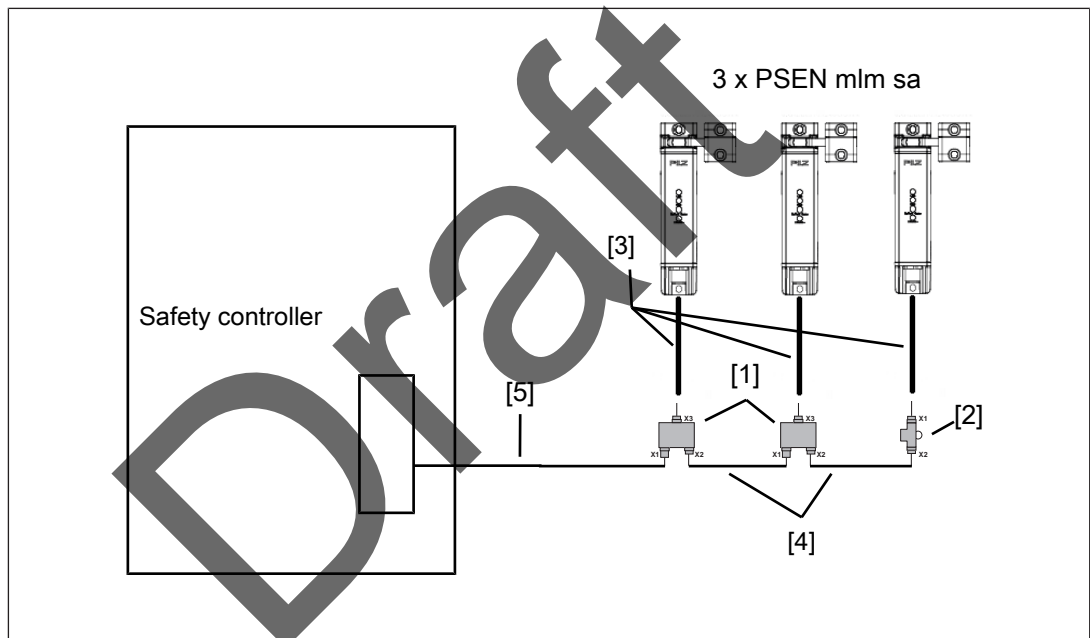

Legend

- [1] PSEN ml Y junction M12 (order number 570486)
 - [2] PSEN ml end adapter (order number 570 487)
 - [3] 12-core cable
PSEN cable M12-12sf M12-12sm (order number depends on the cable length)
 - [4] 8-core cable
PSEN cable M12-8sf M12-8sm (order number depends on the cable length)
 - [5] 8-core cable
PSEN cable M12-8sf (order number depends on the cable length)
- ▶ Series connection for diagnostics with Safety Device Diagnostics

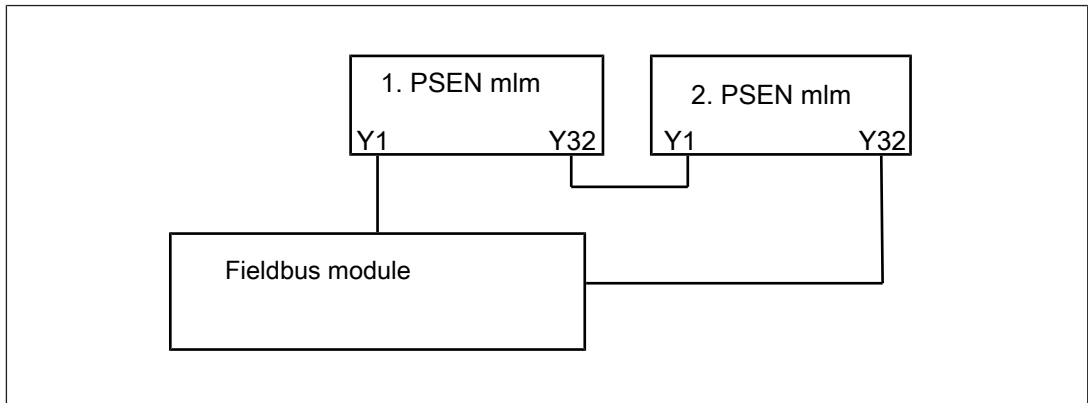

► Series connection for solenoid activation

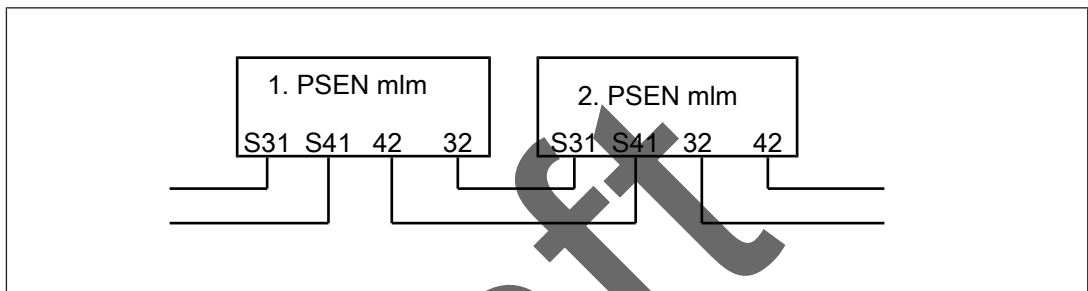

► Series connection for OSSD outputs

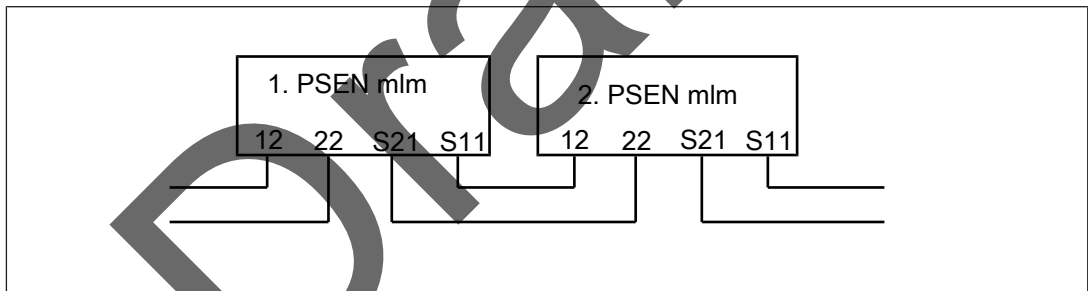

5.7 Safety Device Diagnostics

Safety Device Diagnostics is an option that can be selected independently of the safety-related wiring.

When using Safety Device Diagnostics, up to 16 sensors (of which max. 8 PSEN mlm) can be connected as subscribers to a fieldbus module.

The communication of the sensors with the fieldbus module is automatically built up again with each new supply of the supply voltage. As a result, a sensor can be exchanged, e.g. when servicing, without the need for special measures.

An exchange can be detected via the fieldbus module e.g. through the serial number.

- With Safety Device Diagnostics there are the following diagnostic options for the fieldbus module:
 - Poll information from the sensors (examples: what sensor in the series has switched, at what point could there be an open circuit in the series connection)
 - Read the sensors' configuration parameters (examples: number of teach-in processes remaining, switch's serial number)

- Perform actions (example: poll updated actuator name)
- Specifically deactivate guard locking on individual PSEN mlm devices in a series connection

The results of the sensor diagnostics can be checked already during the installation phase via the display in the fieldbus module, without the need to connect the fieldbus module to the network.

- ▶ Safety Device Diagnostics provide the following benefits for the fieldbus module when wiring:
 - Information is passed on via the fieldbus module directly to the network.
 - Any assignment of inputs/outputs of the fieldbus module to the sensors.
 - This prevents wiring errors and an expansion or reduction of the sensors is possible without the need to change existing wiring.
 - Wiring in accordance with IP20: Rapid installation in the control cabinet is enabled.
 - Wiring in accordance with IP67: Various passive junctions can be used (see [Order reference Accessories \[📖 75\]](#)) to connect several sensors with only one cable from the field in the control cabinet.

Further information on Safety Device Diagnostics can be found in [Additional documents that apply \[📖 8\]](#).

Draft

5.8 Operating modes

The safety switch can be used in various operating modes.

- ▶ Operation without Safety Device Diagnostics
 - Standard operating mode
After every restart the safety switch is in operation without Safety Device Diagnostics.
 - No communication with Safety Device Diagnostics
 - Guard locking is activated/deactivated exclusively via safety inputs S31/S41.
- ▶ Operation with passive use of the Safety Device Diagnostics
 - Safety switch supplies diagnostic data to Safety Device Diagnostics
 - Guard locking is activated/deactivated exclusively via safety inputs S31/S41.
- ▶ Operation with active use of Safety Device Diagnostics
 - Guard locking is deactivated by a combination of a command from Safety Device Diagnostics and the state of safety inputs S31/S41 (S31/S41 must have a high signal).
The safety requirements are guaranteed by the signals at safety inputs S31/S41 (the fieldbus for Safety Device Diagnostics communication is not safety-related).

Draft

5.8.1 Operation without Safety Device Diagnostics

5.8.1.1 Timing diagram, case 1 (operation without Safety Device Diagnostics)

- ▶ [1] The safety gate is open. Diagnostic input Y1 is activated (high), the auxiliary release is not operated (low).
- ▶ [2] Safety inputs S11/S21 signal that guard locking has been activated successfully on the preceding device in the series connection (high).
- ▶ [3] The safety gate is closed, the diagnostic-/signal output Y32 signals that the safety gate is closed (high).
- ▶ [4] Guard locking is requested via safety inputs S31/S41. As soon as guard locking is safely secured, safety outputs 12/22 are activated (high).
- ▶ [5] The safety gate is now securely locked.
- ▶ [6] Execution of the hazardous machine function is now permitted.

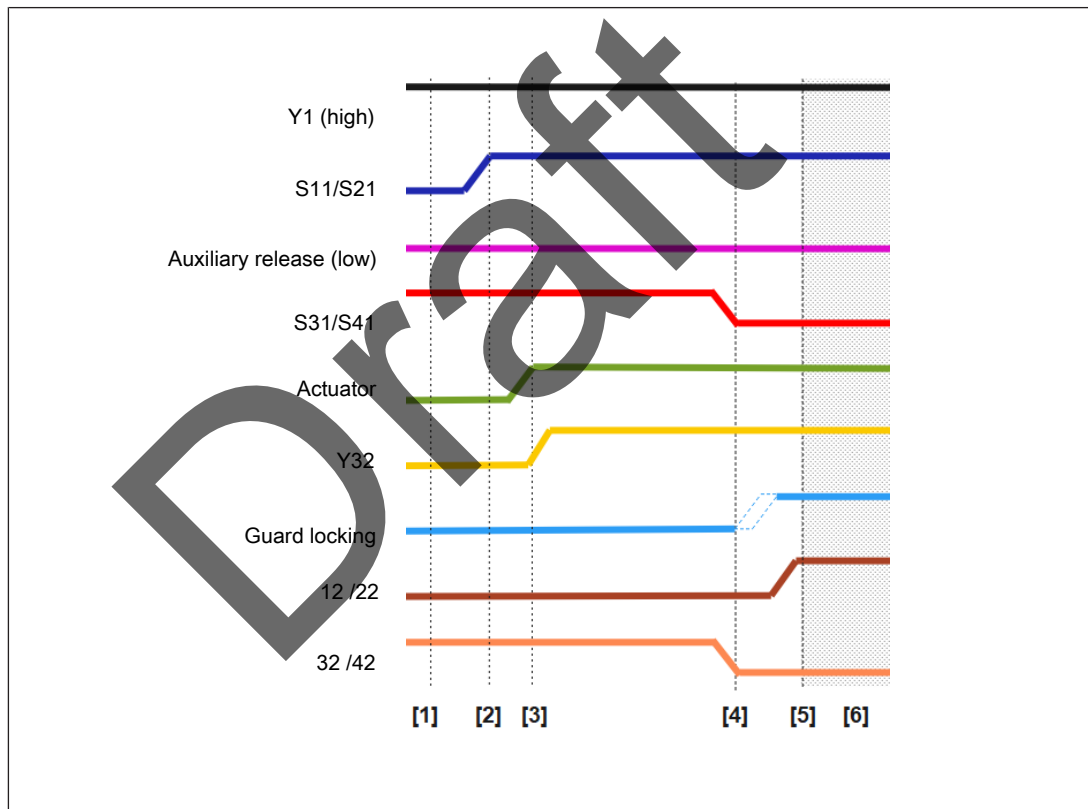

Fig.: Timing diagram, case 1

Legend

- [1] Safety gate open
- [2] Series connection input switches to high
- [3] Safety gate closed
- [4] Guard locking requested (by safety controller)
- [5] The safety gate is securely locked (guard locking is activated)
- [6] Execution of the hazardous machine function is permitted

5.8.1.2 Timing diagram, case 2 (automatic guard locking when closing the safety gate)

- ▶ The safety gate is closed and is securely locked. The hazardous machine function is executed.
- ▶ [1] Guard locking is deactivated via safety inputs S31/S41 (high). Safety outputs 12/22 are deactivated. (low).
- ▶ [2] The safety gate is opened, the diagnostic-/signal output Y32 signals that the safety gate is open (low).
- ▶ [3] Guard locking is requested via safety inputs S31/S41 (low).
- ▶ [4] The safety gate is closed again, the diagnostic-/signal output Y32 signals that the safety gate is closed (high). Guard locking is activated automatically.
- ▶ [5] As soon as guard locking is safely secured, safety outputs 12/22 are activated (high).
- ▶ [6] Execution of the hazardous machine function is once again permitted.

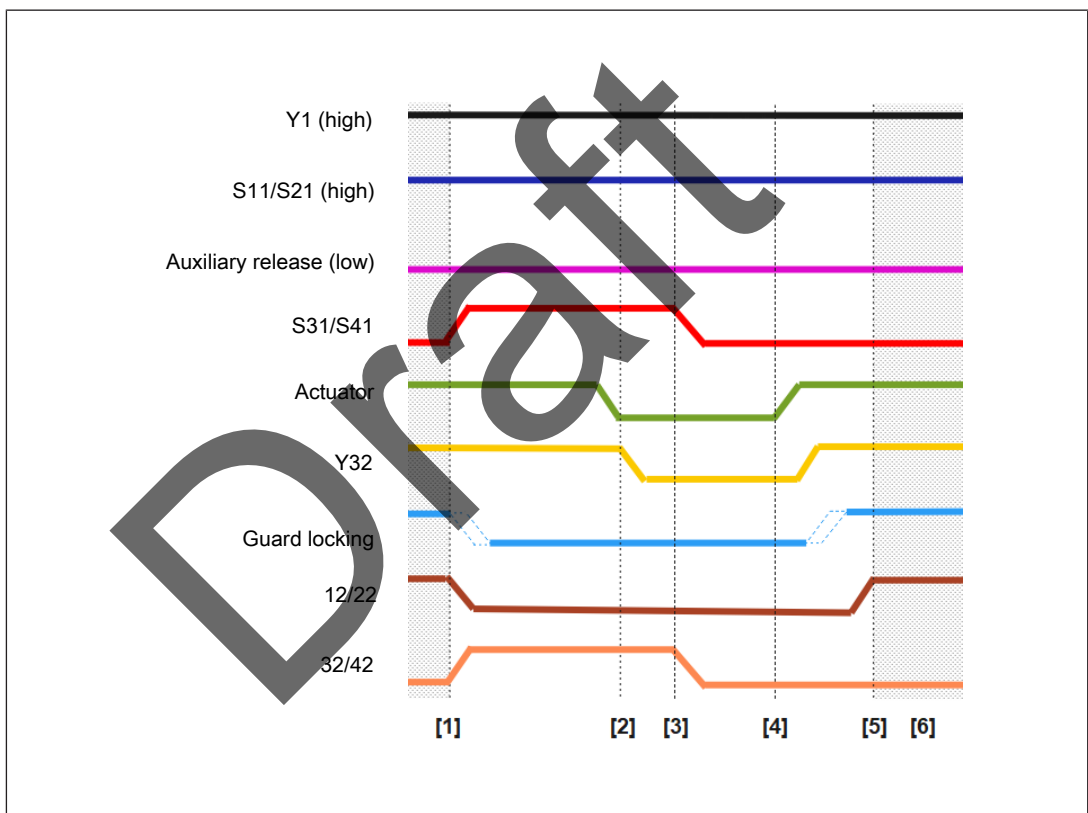

Fig.: Timing diagram, case 2

Legend

- [1] Deactivation of guard locking is requested (by safety controller)
- [2] Safety gate open
- [3] Safety gate guard locking is requested (by safety controller)
- [4] Guard locking is activated automatically when closing the gate (power to unlock)
- [5] The safety gate is securely locked (guard locking is activated)
- [6] Execution of the hazardous machine function is permitted

5.8.2 Operation with active use of Safety Diagnostics

- ▶ [1] The safety gate is closed and is securely locked. The hazardous machine function is executed. Safety inputs S11/S21 signal that guard locking has been activated successfully on the preceding device in the series connection (high). Diagnostic input Y1 is activated (high), the auxiliary release is not operated (low).
- ▶ [2] Deactivation of guard locking is requested via safety inputs S31/S41 (high).
- ▶ [3] Gate guard locking can now be deactivated with an SDD command.
- ▶ [4] The safety gate is opened.
- ▶ [5] Guard locking is requested via safety inputs S31/S41 (low).
- ▶ [6] The safety gate is closed again and guard locking is activated automatically, the guard locking signal switches to high.
- ▶ [7] As soon as guard locking is safely secured, safety outputs 12/22 are activated (high).
- ▶ [8] Execution of the hazardous machine function is once again permitted.

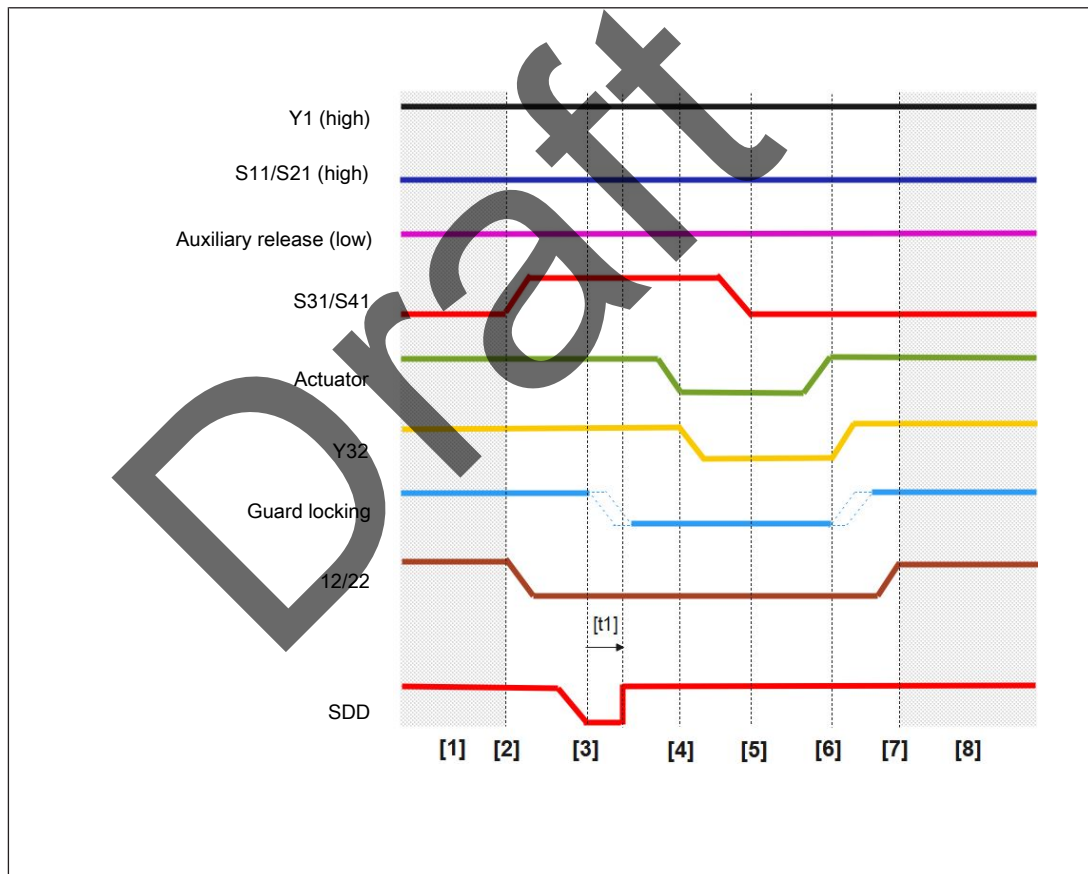

Fig.: Timing diagram: Operation with active use of Safety Device Diagnostics

Legend

- [1] Execution of the hazardous machine function is permitted
- [2] Deactivation of guard locking is requested (by safety controller)
- [3] Guard locking is deactivated via SDD guard locking command (not safety-related)
- [4] Safety gate open
- [5] Safety gate guard locking requested (by safety controller)

- [6] Safety gate closed
- [7] Guard locking is activated automatically by closing the gate
- [8] Execution of the hazardous machine function is permitted
- [t1] Validity time for SDD command, the latest time within which guard locking must be deactivated via S31/S41

5.9 Block diagram

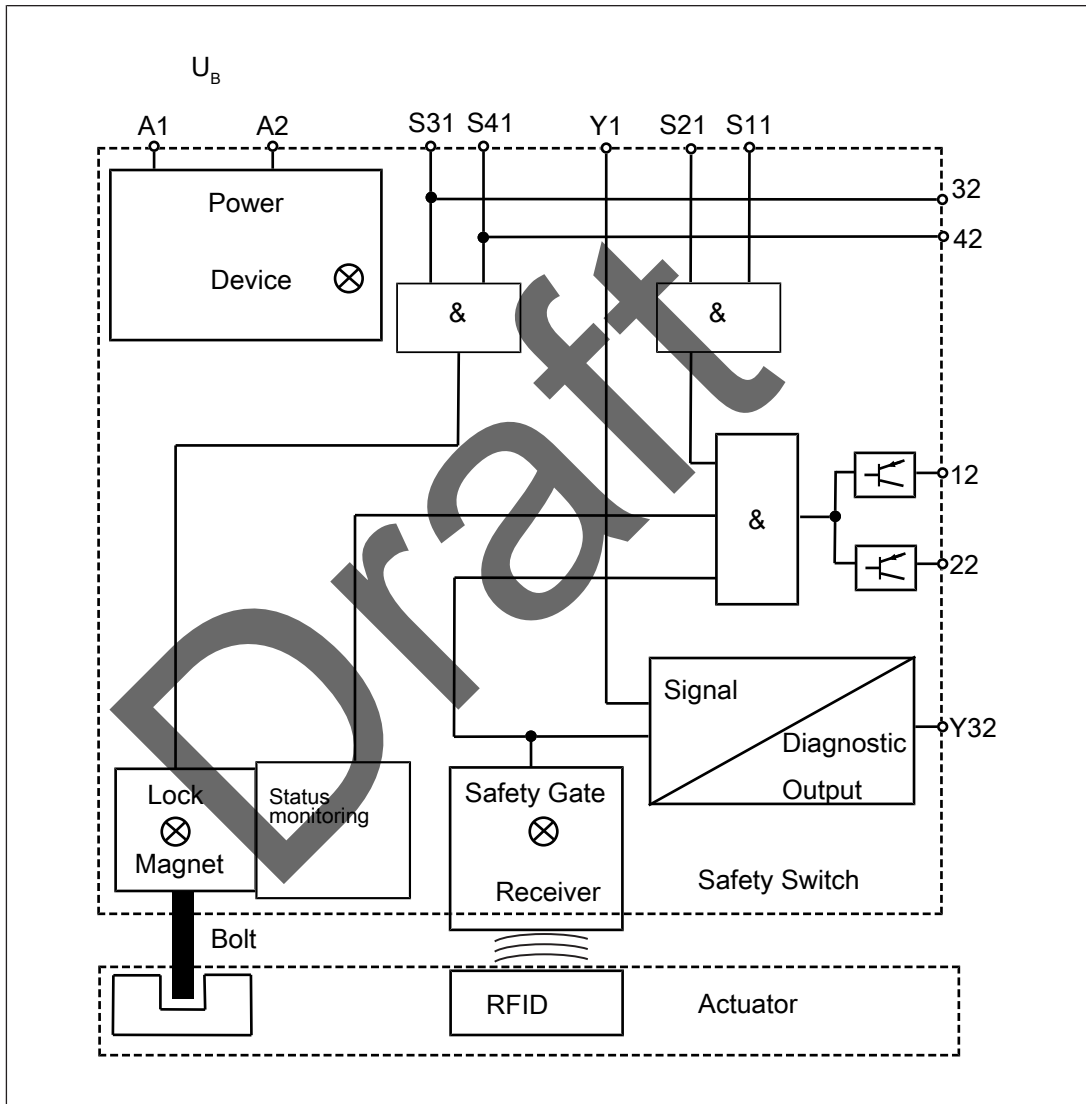



Fig.:

Legend

- [U_B] Supply Voltage
A1: +24 V
A2: 0 V
- [S31], [S41] Safety inputs
Activation of solenoid to open and close guard locking
- [Y1] Diagnostic input

[S21], [S11]	Safety inputs (see Series connection [ 33])
[32], [42]	Safety outputs for activating the solenoid on the next safety switch in the series connection (see Series connection [ 33])
[12], [22]	Safety outputs
[Y32]	Signal/diagnostic output

5.10 Auxiliary release

The auxiliary release enables guard locking to be opened from the access side to the danger zone.



NOTICE

The auxiliary release may only be operated once the machine is at standstill.

The safety switch has auxiliary releases on two opposite sides.

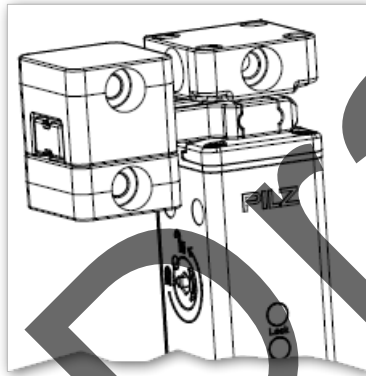

Auxiliary release
PSEN mlm with actuator a

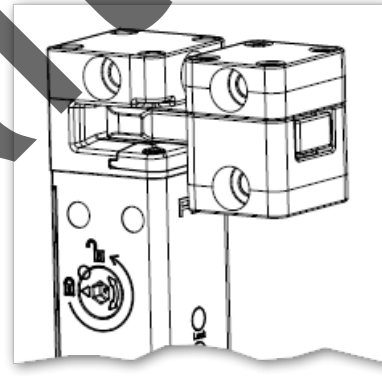

Auxiliary release
PSEN mlm with actuator b



INFORMATION

If guard locking is deactivated using the auxiliary release, there is a low signal at safety outputs 12 and 22. A warning will be output (see chapter [Operation](#) [ 56]). The safety switch does **not** switch to the fault condition.

It is possible to open guard locking using the control system.



NOTICE

The auxiliary release does not represent a safety function. The operator is responsible for using an appropriate auxiliary release, depending on the specific application. A hazard assessment can be carried out as an option, and specifications from the product standard must be adhered to. The functionality of the auxiliary release should be checked regularly.

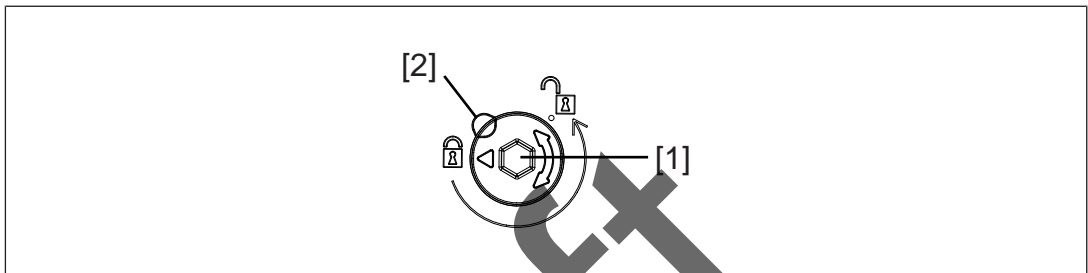

Fig.: Auxiliary release

Legend

- [1] Auxiliary release screw, hexagon socket with wrench size 4 (SW4)
- [2] Marked area for locking varnish (supplied without locking varnish)

Operating principle

1. Using an Allen key (SW4), rotate the auxiliary release screw [1] as far as it will go in the direction of the arrow (max. 230°). The guard locking pin is displaced and the bolt is released. The safety gate to the danger zone can be opened.

5.10.1 Recommissioning

Recommission the safety switch

1. Using an Allen key (SW4), rotate the auxiliary release screw [1] (see [diagram \[25\]](#)) as far as it will go in the opposite direction to the arrow (max. 230°).
2. Use varnish to seal the marked area/indent [2] (see [diagram \[25\]](#)).
3. Carry out a function test on the safety switch and actuator. The safety function may only be checked by qualified personnel.



INFORMATION

If the auxiliary release screw is not turned back correctly after use, guard locking cannot be activated/deactivated.



NOTICE

Once the auxiliary release has been operated, guard locking cannot be re-activated until the safety gates are opened and then closed again.

Draft

6 Wiring

6.1 Important information

- ▶ Information given in the [Technical details \[63\]](#) must be followed.
- ▶ Ensure that the connection cable is disconnected from the power supply when it is plugged into the safety switch.

6.2 Pin assignment, connector and cable



NOTICE

The colour marking for the connection lead only applies for the cable that Pilz supplies as an accessory

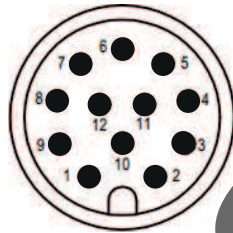

12-pin M12 male connector

PIN	Function	Terminal designation	Cable colour (Pilz cable)
1	+24 V UB	A1	Brown
2	0 V UB	A2	Blue
3	Operation of solenoid to open and close guard locking (channel 2)	S41	White
4	Safety output channel 1	12	Green
5	Operation of solenoid to open and close guard locking (channel 1)	S31	Pink
6	Safety output channel 2	22	Yellow
7	Safety input channel 1	S11	Black
8	Signal output/diagnostic output	Y32	Grey
9	Diagnostics input	Y1	Red
10	Safety input channel 2	S21	Purple
11	Operation of solenoid of the next safety switch in the series connection (channel 1)	32	Grey-pink

PIN	Function	Terminal designation	Cable colour (Pilz cable)
12	Operation of solenoid of the next safety switch in the series connection (channel 2)	42	Red-blue

**NOTICE**

Fasten the connection cable with a torque of 0.6 Nm.

6.3**EMC requirements and electrical safety**

- ▶ Ensure the wiring and EMC requirements of EN 60204-1 are met.
- ▶ UL requirement: The supply voltage to the safety switch must be protected with a quick-acting fuse (see [Technical details](#) [ 63]).
- ▶ The power supply and the components connected to the PSEN mIm must meet the regulations for extra low voltages with protective electrical separation (SELV, PELV).
- ▶ The power supply must have an overvoltage protection of ≤ 35 VDC.

**INFORMATION**

Only use safety relays with a 24 VDC supply voltage. Safety relays with a wide-range power supply or in AC device versions have internal potential isolation and are not suitable as evaluation devices.

7 Connection to control systems and evaluation devices

7.1 Important information

The selected evaluation device must have the following properties:

- ▶ 2-channel with plausibility monitoring

Both OSSDs must change the switch state synchronously. In particular, the evaluation device must monitor that the state of both OSSDs was "Gate unlocked" before both return to the "Gate locked" state and vice-versa.

- ▶ OSSD signals are evaluated through 2 channels.
- ▶ The use of Safety Device Diagnostics is described in the System Description "Safety Device Diagnostics".



WARNING!

Hazard due to loss of the safety function

Depending on the application, serious injury or death may result. The safety function can be lost when the safe state is not checked regularly.

- Use an evaluation device/safety system to test whether the plant is in a safe condition.
- Do not operate the solenoid via S31/S41 unless the plant is in a safe condition.

7.2 Minimum requirements for activation of guard locking

Use in PL d (Cat. 3) applications

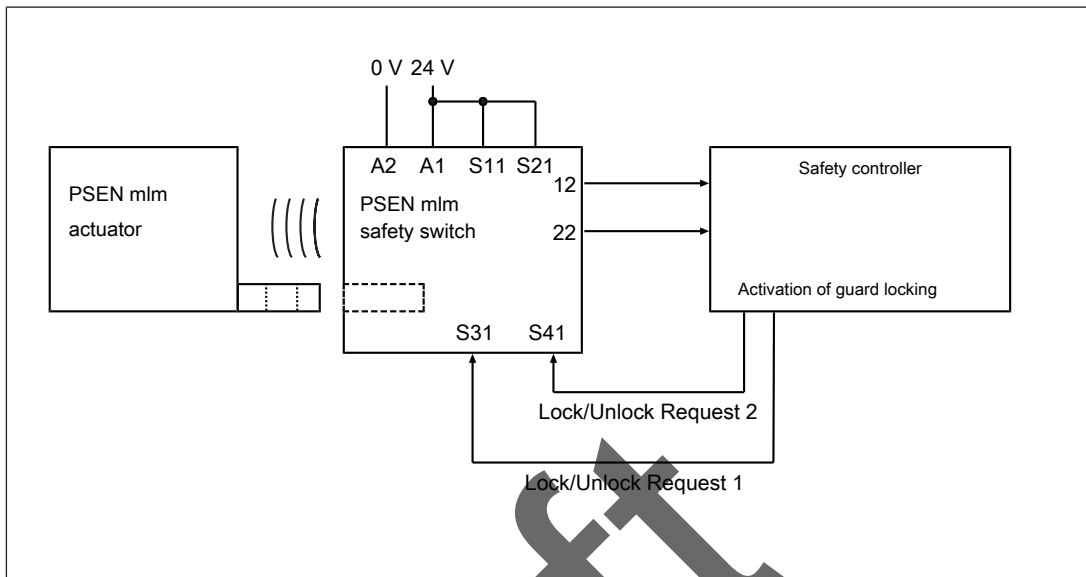

- ▶ Safety inputs S31 and S41 (solenoid activation) have 2-channel operation via safe outputs, which are suitable for PL d (Cat. 3) applications
- ▶ Use 2-channel operation for safety inputs S31 and S41 (solenoid activation)
- ▶ Use 2-channel processing for safety outputs (12 and 22)

Use in PL d (Cat. 2) applications

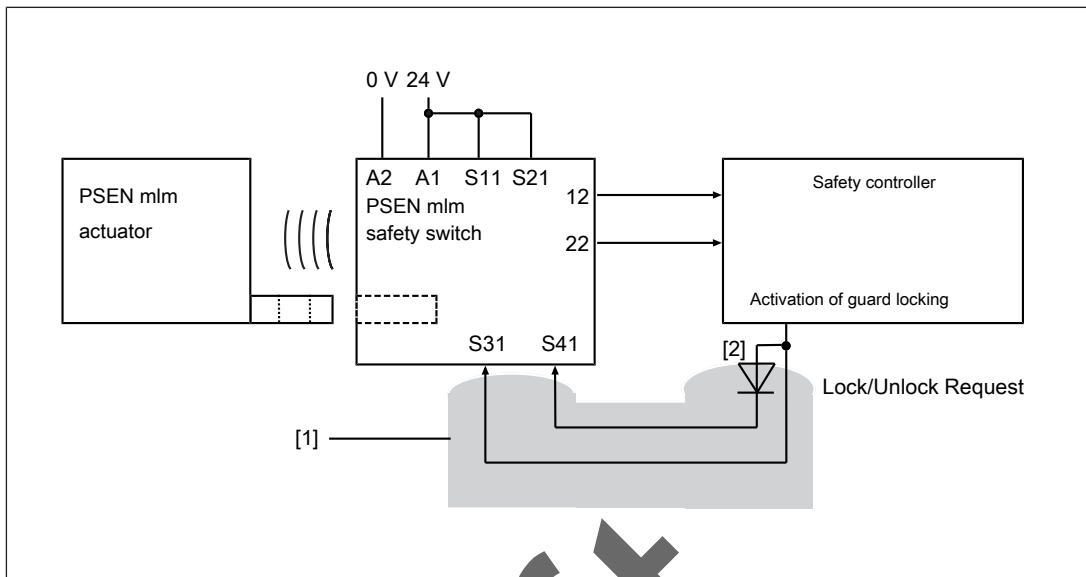

Legend

[1] Protected cable layout

[2] Diode optional (see [Series connection \[33\]](#), "Examples for cable lengths"), to prevent the reduction of the maximum total cable length.

Use in PL d (Cat. 2) 1-channel:

With a series connection of 4 to 8 safety switches, the total cable length is reduced by up to 15 m. This reduction can be avoided by installing a diode.



WARNING!

Hazard due to loss of the safety function

Serious or fatal injury could result, depending on the application. Shorts across the signal cable can cause the safety inputs to activate and lead to the loss of the safety function.

- Exclude shorts through appropriate measures (e.g. protected cable layout, see EN ISO 13849-2).

- ▶ 1-channel operation for safety inputs S31 and S41 (solenoid operation) via safe outputs
- ▶ Use 2-channel processing for safety outputs (12 and 22)
- ▶ Use 1-channel operation for interconnected safety inputs S31 and S41 (solenoid activation)
- ▶ Exclusion of shorts across signal cables through appropriate measures (e.g. protected cable layout, see EN ISO 13849-2)

7.3 Single connection

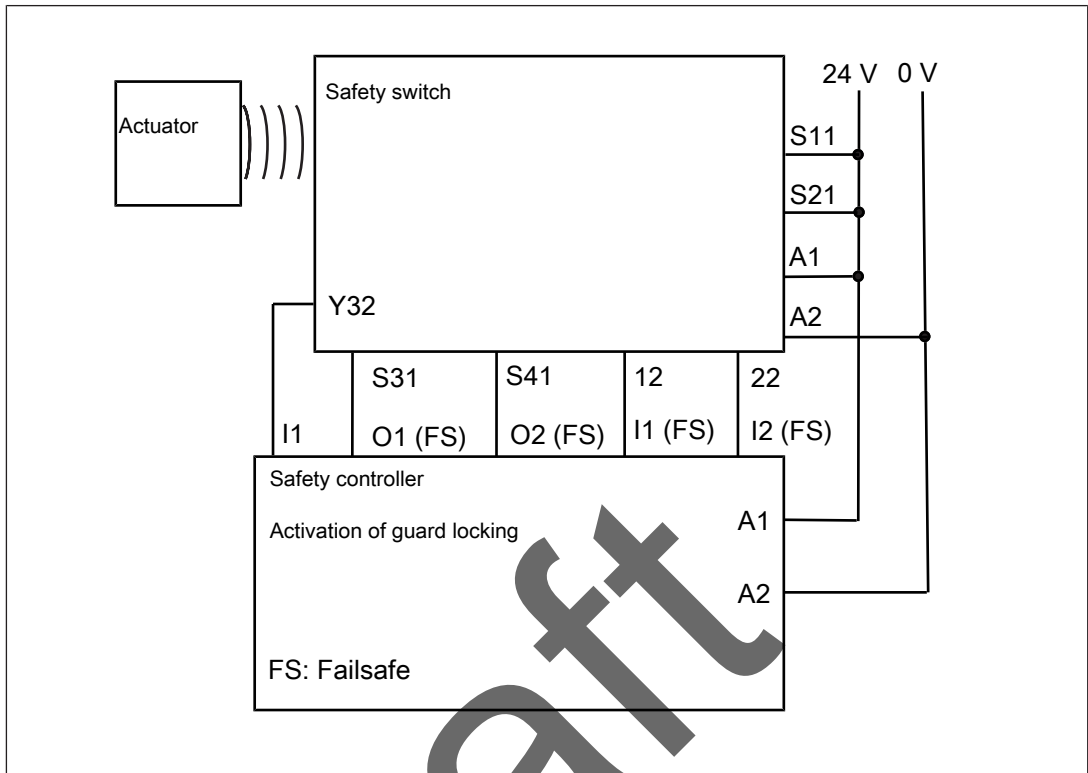

7.4 Series connection



NOTICE

Extension of delay-on de-energisation

When several (n) devices are connected in series, the delay-on de-energisation time is multiplied by the number of interconnected safety switches. The max. delay-on de-energisation is made up of the risk time (see [Technical details \[63\]](#)) + (n-1) x max. delay-on de-energisation of the safety inputs + max. delay-on de-energisation of the evaluation device.



NOTICE

Increased current at the solenoid input

When several (n) devices are connected in series, the input current is multiplied by the number of safety switches connected in series (see [Technical details \[63\]](#)).

Up to 8 safety switches can be connected in series.

In practice, the maximum possible number will be limited by the following parameters, among others:

- ▶ The required performance level (e.g. PL d (Cat. 3)),
- ▶ The maximum delay or risk time permitted by the application,
- ▶ Cable length (see notes on cable lengths),
- ▶ Height of supply voltage.

Ensure there is sufficient supply voltage, taking inrush currents and fusing into consideration.

Notes on cable lengths

- ▶ The values are determined under the following conditions:

Room temperature (25°C)

Cable cross section 0.25 mm²

With the output current per output (12, 22, Y32), it is presumed that this need only be supplied by one device. All the others are loaded with the input current from downstream safety switches, which is already included in the total current.

The devices are spread over the total cable length (in this case: an example with 6 safety switches).

The total cable length is the distance to the furthest device. Stub lines from Y-adapters to less distant devices are not taken into consideration.

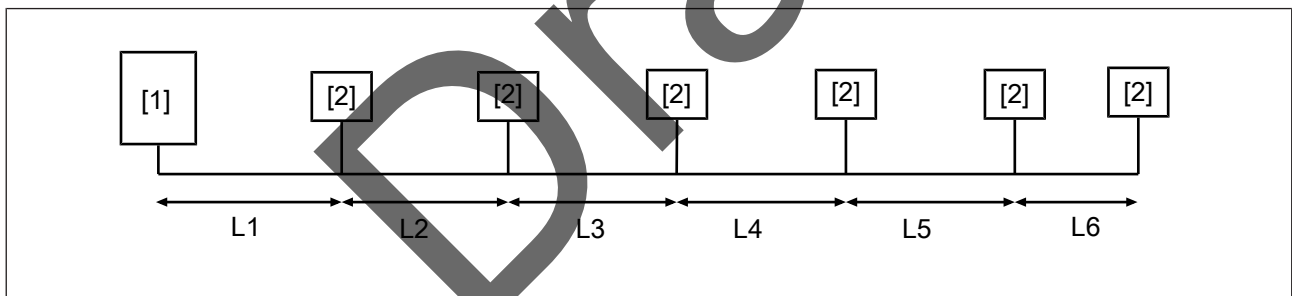

Legend

- [1] Safety controller
- [2] Safety switch PSEN mlm

Examples for cable lengths

<p>Use in PL d (Cat. 3) applications (see Minimum requirements for activation of guard locking [31])</p> <p>2-channel application</p> <p>Series connection of 1 to 8 safety switches</p>	
Supply voltage at the safety controller = 24.0 V	Supply voltage at the safety controller = 28.8 V
Total cable length: 45 m	Total cable length: 75 m

Use in PL d (Cat. 2) applications (see [Minimum requirements for activation of guard locking](#) [ 31])

1-channel application

Series connection of 1 to 3 safety switches*

Supply voltage at the safety controller = 24.0 V	Supply voltage at the safety controller = 28.8 V
Total cable length: 45 m*	Total cable length: 75 m*

*With a series connection of 4 to 8 safety switches, the total cable length is reduced by up to 15 m.

This reduction can be avoided by installing a diode when connecting S41 in the control cabinet (see [Minimum requirements for activation of guard locking](#) [ 31], "Use in PL d (Cat. 2) applications").

Draft

Connecting the safety switches in a series connection

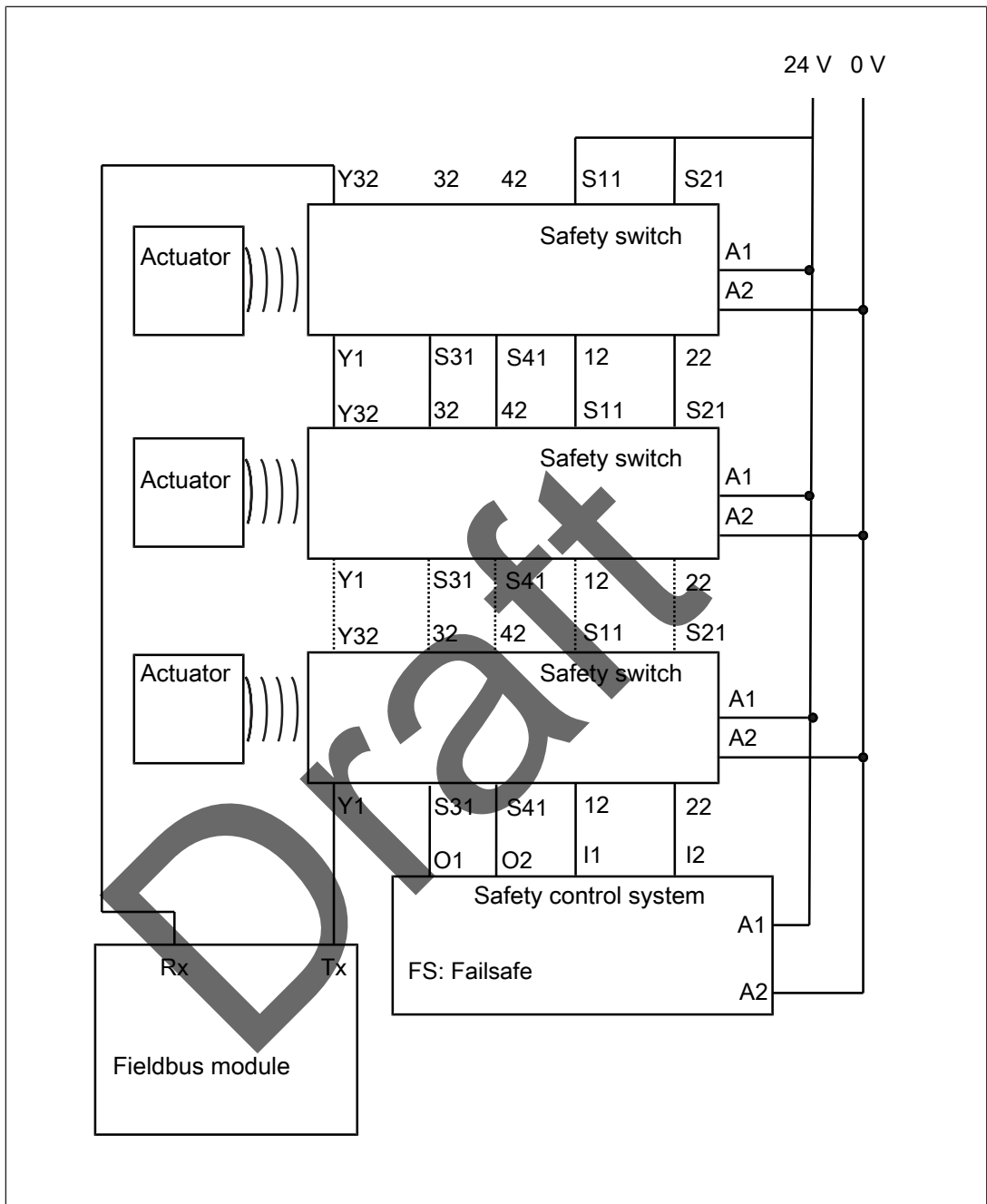

The following options are available for connecting the safety switch in a series connection:
Wiring to the safety controller via PSEN ml Y junction

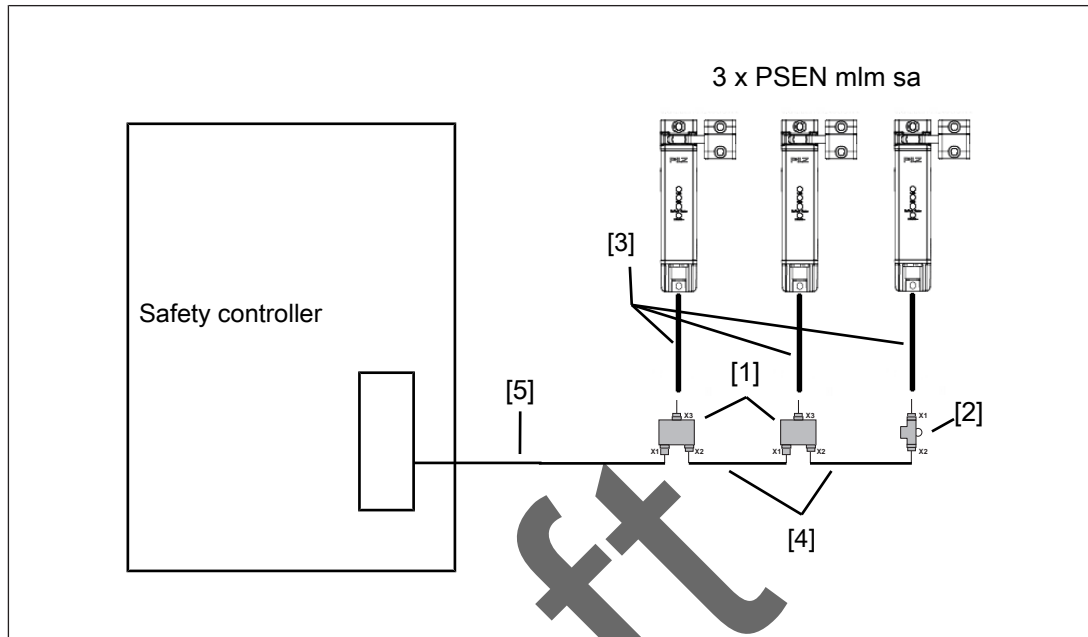

Legend

- [1] PSEN ml Y junction M12 (order number 570486)
 - [2] PSEN ml end adapter (order number 570487)
 - [3] 12-core cable
PSEN cable M12-12sf M12-12sm (order number depends on the cable length)
 - [4] 8-core cable
PSEN cable M12-8sf M12-8sm (order number depends on the cable length)
 - [5] 8-core cable
PSEN cable M12-8sf (order number depends on the cable length)
- ▶ When establishing the series connections that connect to the safety controller, use the following adapters and cables:
 - PSEN ml Y junction M12
 - PSEN ml end adapter
 - PSEN cable M12-12sf M12-12sm
 - PSEN cable M12-8sf M12-8sm
 - ▶ Connection in the control cabinet at the terminal block
 - Connect a 12-core cable (for example PSEN cable M12-12sf M12-12sm) to the safety switch and guide it to the terminal block in the control cabinet.



NOTICE

Before commissioning, check the [Series connection of the safety channels](#) [59].

7.5 Connection to Pilz evaluation devices

The safety switch can be connected to Pilz evaluation devices.

Suitable Pilz evaluation devices are, for example:

- ▶ PNOZmulti for safety gate monitoring
Configure the switch in the PNOZmulti Configurator with switch type 3.
- ▶ PSSuniversal PLC for safety gate monitoring with function block FS_SafetyGate

The correct connection to the respective evaluation device is described in the operating manual for the evaluation device. Make sure that the connection is made in accordance with the specifications in the operating manual for the selected evaluation device.

Connection to PNOZmulti is illustrated by way of example.

Connection example with PNOZmulti and Safety Device Diagnostics (SDD)

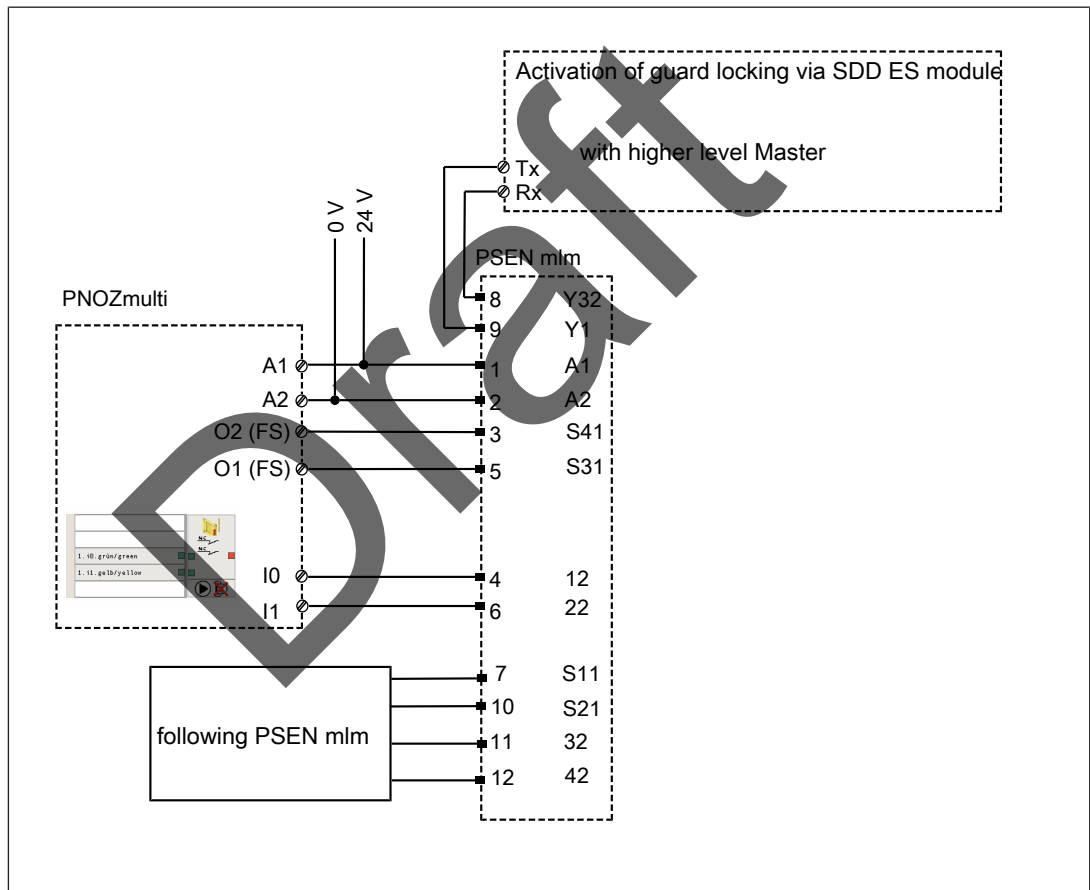

8 Teaching in the actuator

A distinction is made between the following Pilz coding types:

Coded	The safety switch PSEN mlm x sa 1.1 switch accepts any PSEN mlm actuator.
Fully-coded	The safety switch PSEN mlm x sa 2.1 switch accepts only one PSEN mlm actuator. A maximum of 8 learning procedures are possible for that one actuator.
Uniquely coded	The safety switch PSEN mlm x sa 2.2 switch accepts only one PSEN mlm actuator. Only one learning procedure is possible for that one actuator.

PSEN mlm x sa 1.1

Any corresponding Pilz actuator (see [Technical Details \[63\]](#)) is detected as soon as it is brought into the response range.

The response range is achieved when the actuator is inserted into the safety switch.

PSEN mlm x sa 2.1

Teaching in the actuator for the first time:

The first actuator to be detected by the safety switch (see [Technical details \[63\]](#)) is taught in automatically as soon as it is brought into the response range.

To teach in a new actuator:

- ▶ A maximum of 8 learning procedures are possible.
1. The actuator that is to be taught in must be brought into the safety switch's response range as the only transponder. As soon as the actuator is detected, the "Safety Gate" LED will flash yellow.
 2. After a waiting period of 20 s, the "Safety Gate" LED has the following status: yellow, flashes quickly. Trigger a system reset in the next 120 s by interrupting the supply voltage.
 3. When the supply voltage is switched back on, the learning procedure is complete and the number of permitted additional learning procedures is reduced by 1.



NOTICE

- The actuator must not be removed during the learning procedure.
- It is no longer possible to reteach this actuator on the same safety switch.

PSEN mIm x sa 2.2

The **first** actuator to be detected by the safety switch (see [Technical details](#) [ 63]) is taught in automatically as soon as it is brought into the response range.

The safety gate LEDs light up a constant yellow when the actuator is detected (see [Normal operation](#) [ 56]).



NOTICE

No other actuator may be taught in once this actuator has been taught.

Draft

9 Installation

9.1 Important information





NOTICE

Install the safety switch and actuator so that the possibilities of defeat are reduced to a minimum (see guidelines for reducing the possibilities for defeating interlocking devices in EN ISO 14119).



NOTICE

Install safety switch and actuator so that it is not possible to reach through with hand or finger.

- ▶ Prevent anyone from becoming trapped unintentionally in the danger zone. The safety switch does not have an emergency release.
- ▶ The fastening of safety switch and actuator has to be sufficiently stable to ensure the proper operation of the safety switch and the actuator.
- ▶ Prevent the safety switch and actuator being exposed to heavy shock or vibration.
- ▶ The mounting surfaces for safety switches and actuators can have a max. unevenness of 0.5 mm.
- ▶ The actuator must rest flush on the mounting surface.
- ▶ The safety switch and actuator should be installed opposite each other in parallel.
- ▶ Once installed, it must be possible to operate at least one of the auxiliary releases.
- ▶ Use the same type of screw to attach the safety switch and actuator.
- ▶ Use non-removable flat head locking screws to attach the safety switch and actuator (e.g. cheese-head or pan head screws) or rivets.
- ▶ Use M5 screws with a min. resistance class of 8.8 to attach the safety switch and actuator, and ensure that a minimum screw depth of ≥ 7 mm is achieved.
- ▶ The fastening elements must be prevented from coming loose,
 - on the safety switch: by complying with the max. torque setting (see [Technical details](#)  63]) and medium strength threadlocking adhesive.
 - on the actuator: by complying with the max. torque setting (see [Technical details](#)  63]) and medium strength threadlocking adhesive.
- ▶ Torque setting: Please note the information provided under [Technical details](#)  63]. Don't fully tighten the safety screws until the safety switches and actuators are correctly aligned and the function has been tested.
- ▶ If possible, conceal the installation of the safety switch and actuator.

9.2 Align safety switch and actuator

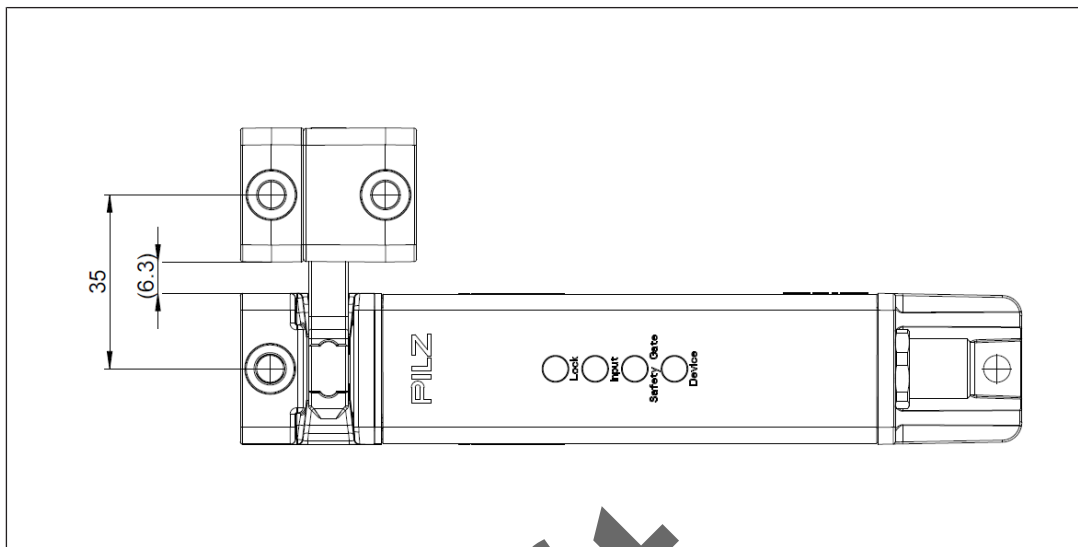
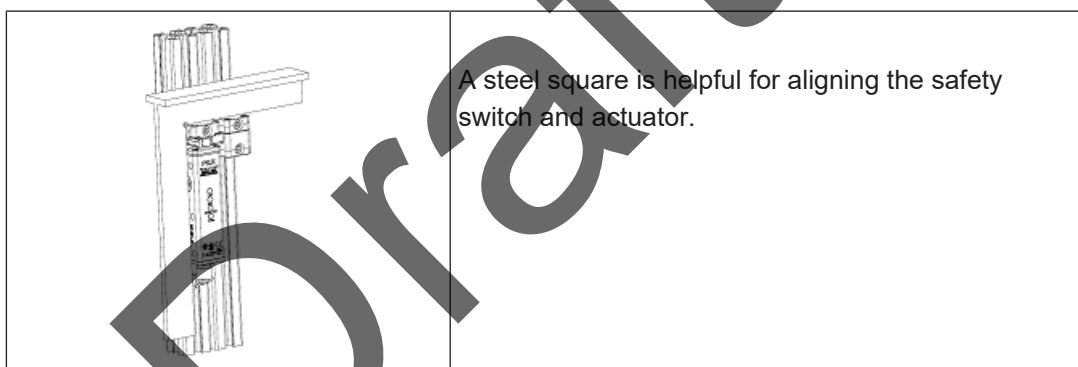

Fig.: Align safety switch and actuator

Comply with the stated dimensions, tolerances, see [Technical details](#) [63].



9.3 Installation of multiple safety switches

When multiple safety switches are installed, you must observe the following minimum distances between them.

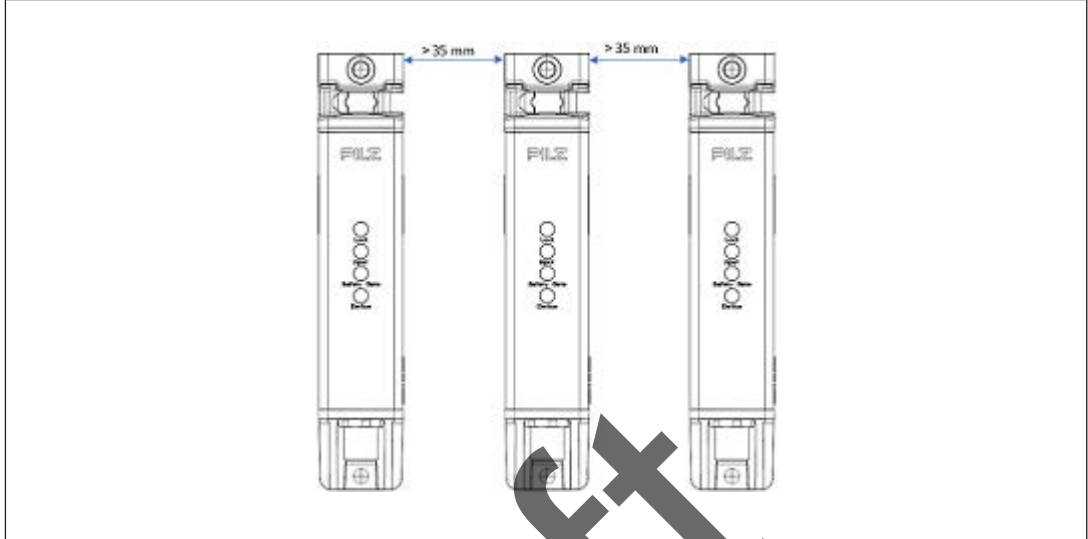

Fig.: Distances, safety switches in parallel > 35 mm

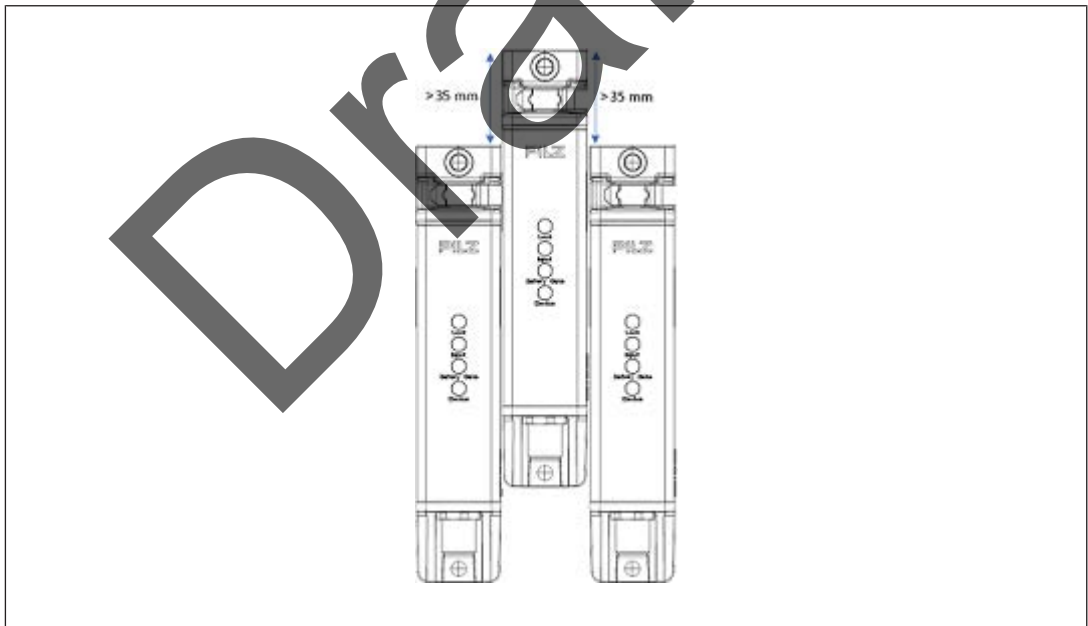

Fig.: Distances, safety switches directly in parallel, with vertical offset > 35 mm

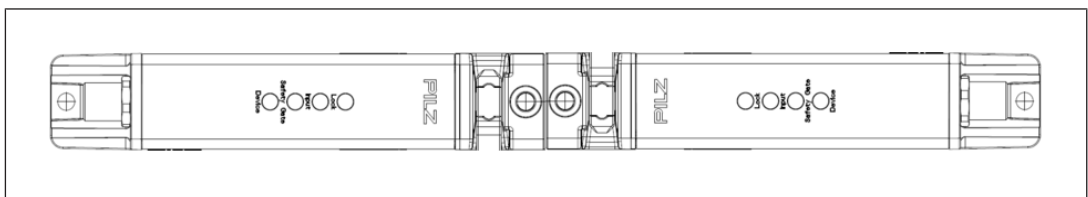

Fig.: Distances, safety switches "head to head", no distance

9.4 PSEN mlm mounting types

The PSENmlock mini can be mounted as an internal or external attachment. External attachment is the preferred mounting type.

9.4.1 External attachment with actuator a

The following mounting examples are based on a 30 x 30 mm profile. With other profiles, mounting plates are required for safety switches and actuators.

9.4.1.1 Installation on sliding gate

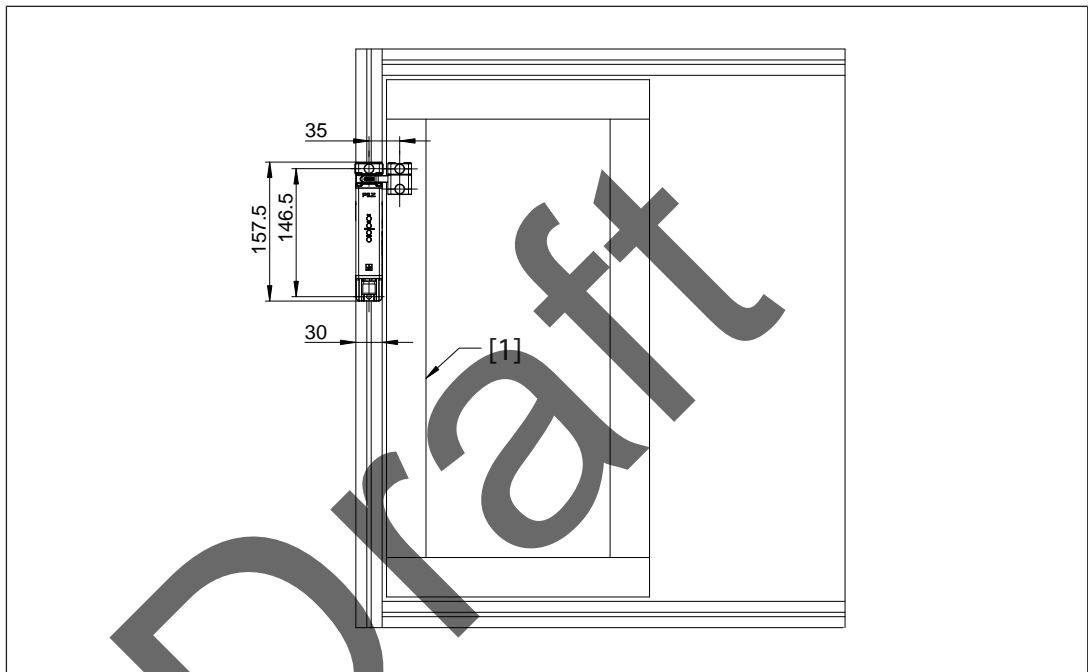

Legend

[1] Sliding gate

- ▶ Use two screws to mount the safety switch on the frame.
 - ⇒ Screw for the actuator: M5 cylinder head screw, 30 mm
 - ⇒ Screw for the male connector: M5 cylinder head screw, 8/10 mm
- ▶ Use two 30 mm M5 cylinder head screws to attach the actuator to the gate.

9.4.1.2 Installation on swing gate

Note the minimum gate radius R, see [Technical details](#)  63].

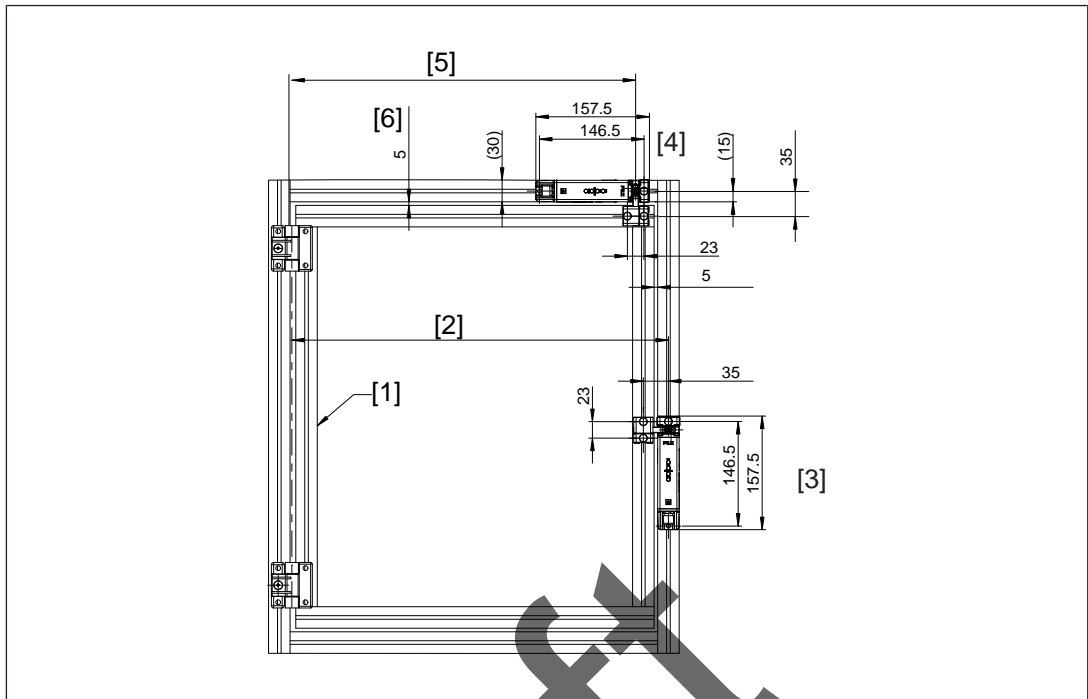

Legend

- [1] Swing gate
- [2] Gate radius R when safety switch is attached parallel to the rotational axis [3]
- [3] Safety switch attached **parallel to the rotational axis**
parallel to the rotational axis = preferred mounting type
- [4] Safety switch attached across the rotational axis
- [5] Gate radius R when safety switch is attached across the rotational axis [4]
- [6] Gap between gate and frame

- ▶ Use two screws to mount the safety switch on the frame.
 - ⇒ Screw for the actuator: M5 cylinder head screw, 30 mm
 - ⇒ Screw for the male connector: M5 cylinder head screw, 8/10 mm
- ▶ Use two 30 mm M5 cylinder head screws to attach the actuator to the gate.

The actuator should engage smoothly into the safety switch.

Maintain a slight parallel offset from the gate's rotation point when installing the actuator.

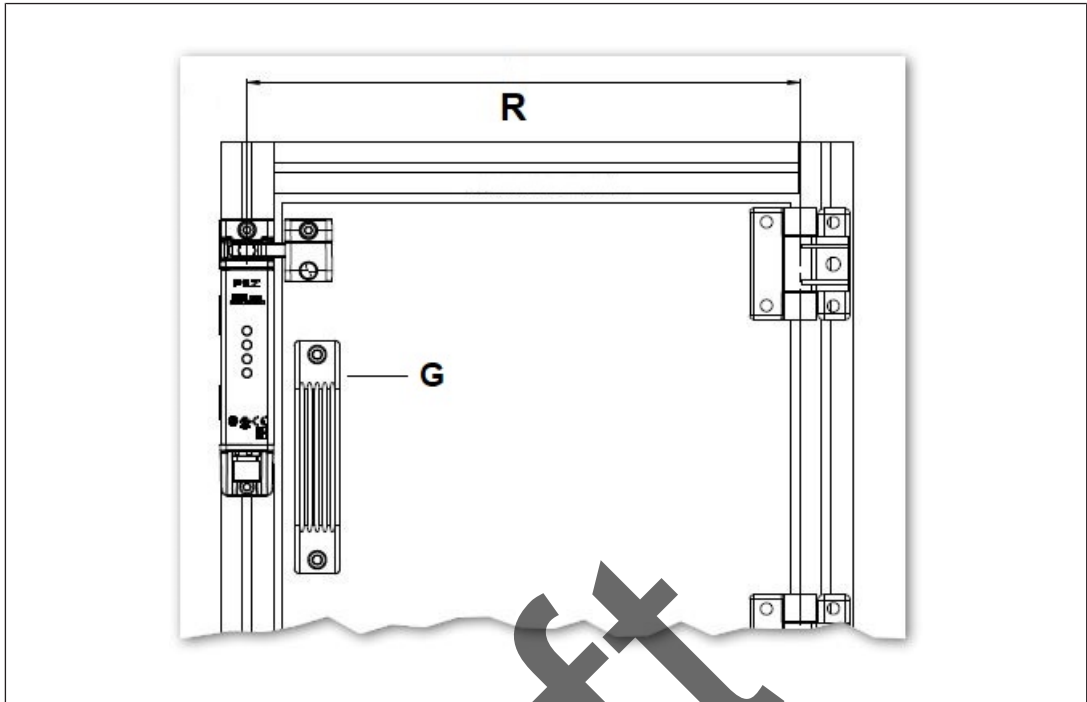
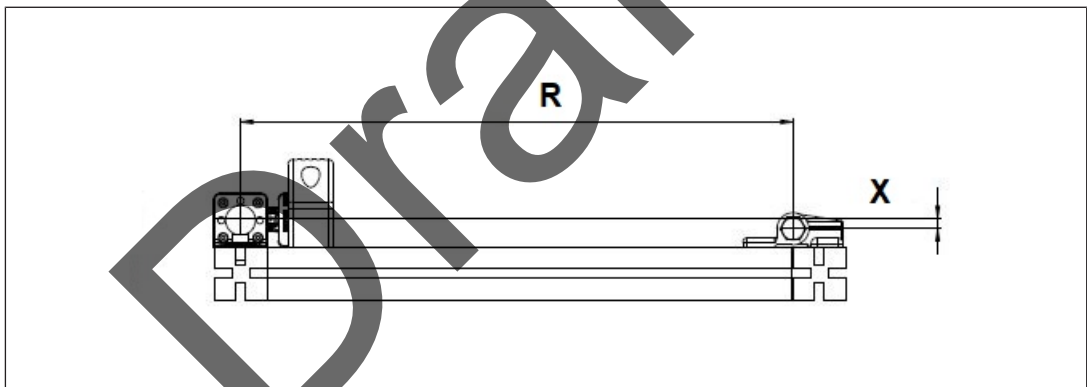

Fig.: External attachment parallel to the rotational axis



Legend

- [R] Gate radius R
- [X] X-dimension
- [G] Handle

Factors that positively influence the smooth insertion of the actuator into the safety switch:

- ▶ Small X-dimension
- ▶ Large gate radius R
- ▶ Little play in the gate bearing
- ▶ Gate sags very little



INFORMATION

The insertion of the actuator into the safety switch is influenced by the above factors. For this reason we recommend you use 3D data to inspect the installation situation, see www.pilz.com.

Mount safety switch on a swing gate across the rotational axis

Depending on the installation boundary conditions, a larger gate radius may be required.

Draft

9.4.2 Internal attachment with actuator b

Depending on the application, mounting plates/mounting brackets may be required for internal attachment of the safety switch with actuator b (see [Internal attachment: Mounting of safety switch and actuator using mounting set 1 \(optional\)](#) [ 52]).

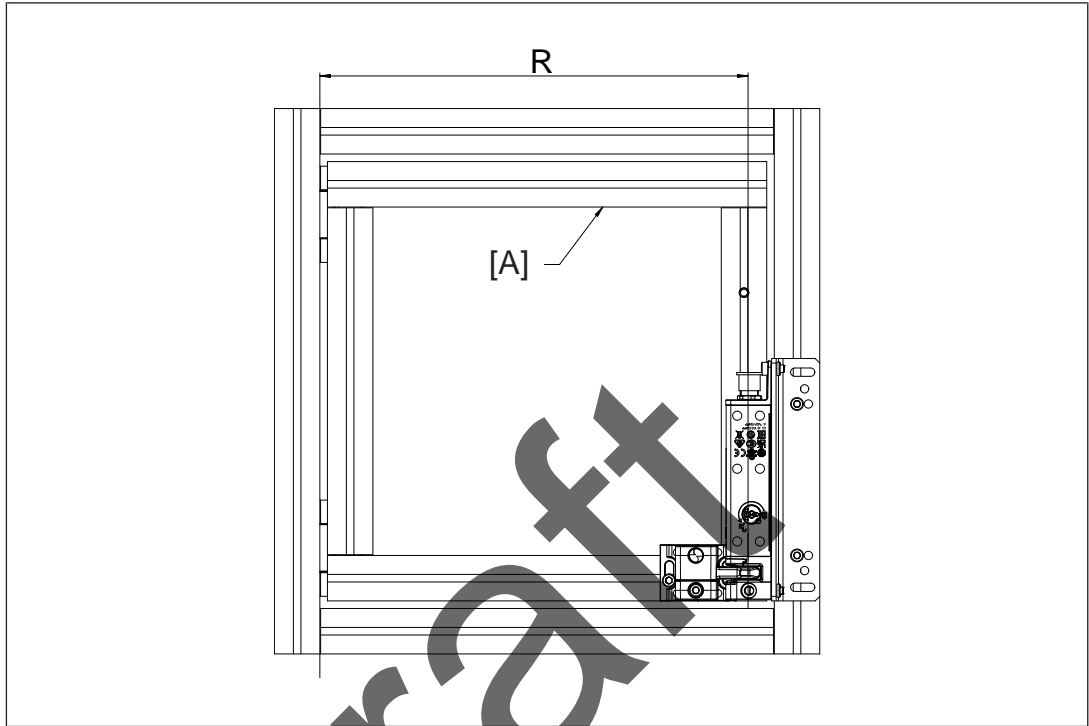
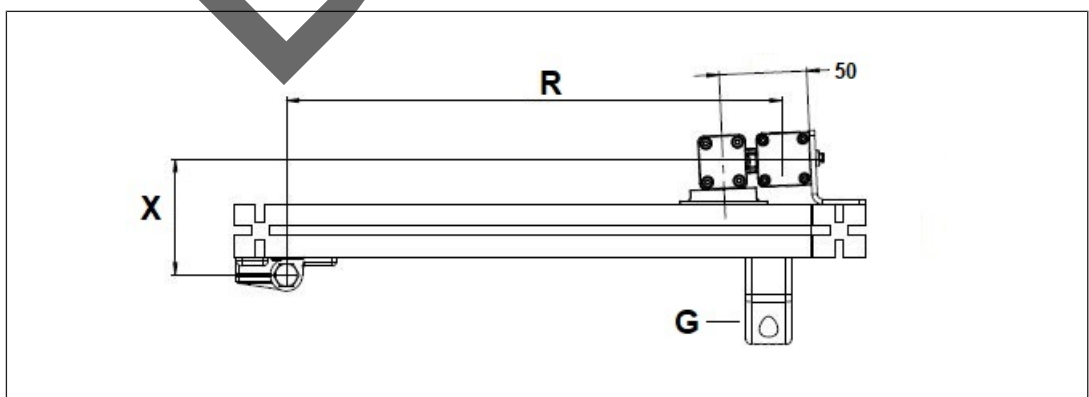

Fig.: Internal attachment parallel to the rotational axis with mounting bracket/mounting plate

Legend

[A] Gate profile 30 x 30 mm



Legend

[R] Gate radius R

[X] X-dimension

[G] Handle on the outside

Factors that positively influence the smooth insertion of the actuator into the safety switch:

- ▶ Small X-dimension

- ▶ Large gate radius R
- ▶ Little play in the gate bearing
- ▶ Gate sags very little



INFORMATION

The insertion of the actuator into the safety switch is influenced by the above factors. For this reason we recommend you use 3D data to inspect the installation situation, see www.pilz.com.



NOTICE

Auxiliary release must be reachable

On the safety switch, ensure that the auxiliary release screw is reachable with an Allen key (SW4) on one of the two sides when the gate/cover/flap is closed.

Draft

9.5 Installation safety switch

- ▶ In order to attach the safety switch at the three possible mounting positions, the foot bracket can be rotated.

As a result, the safety switch can be mounted on the frames of left and right-hinged sliding gates and swing gates. If necessary use a mounting plate or mounting bracket (see Order reference: Accessories).

Different holding forces arise, based on the installation.

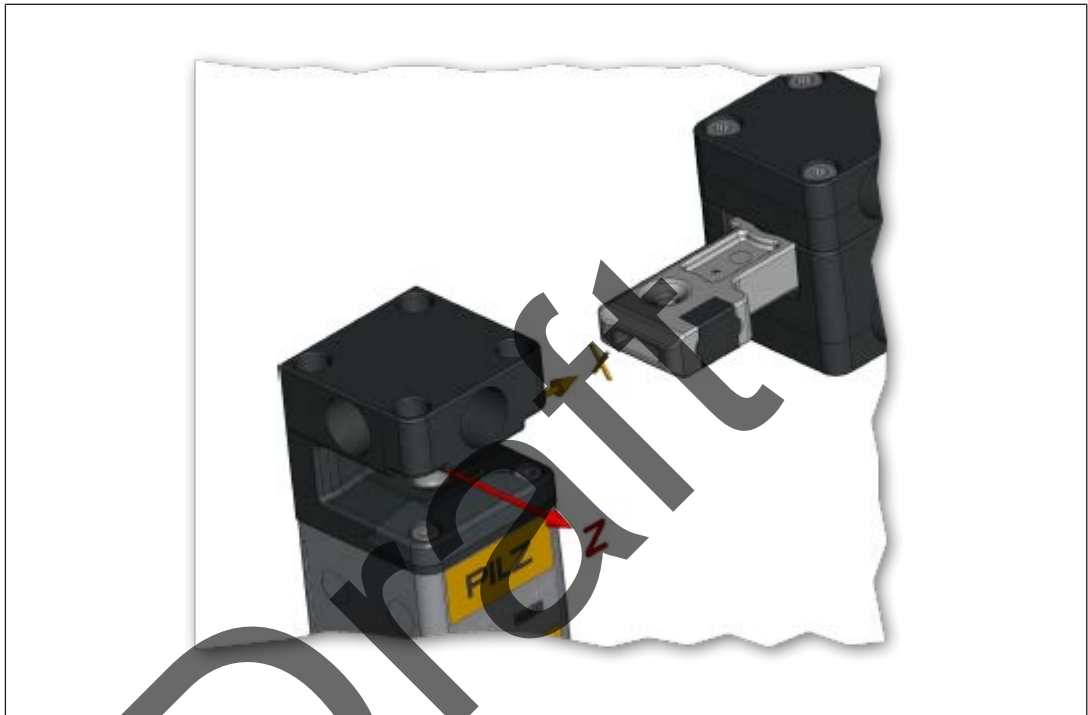
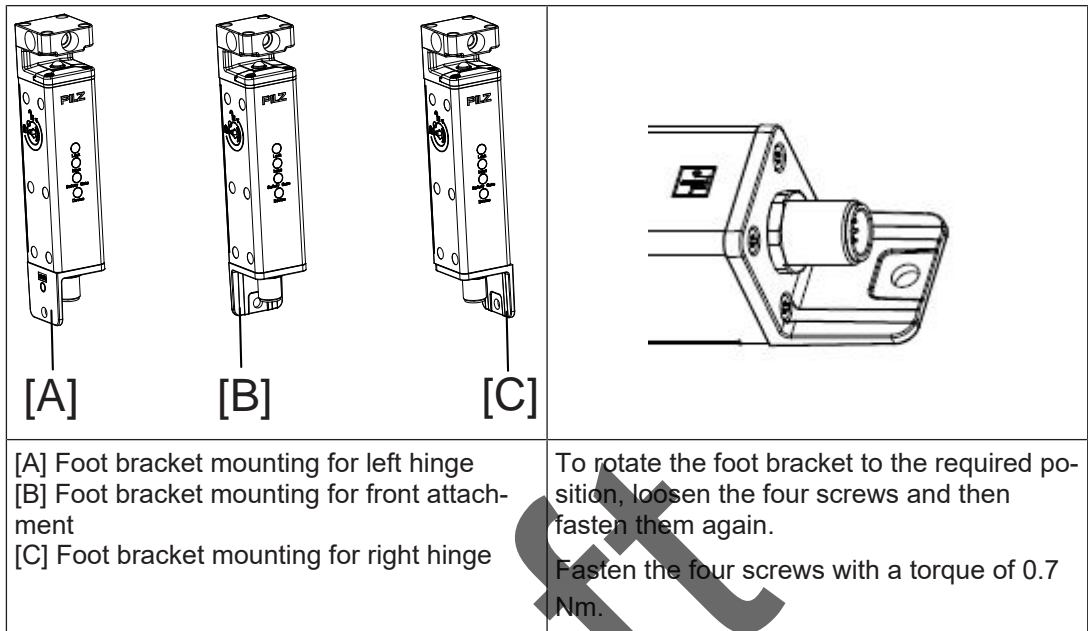

Fig.: Holding force directions

- ▶ Holding force F_{Zn} in Z-direction: 1500 N
- ▶ Holding force F_{Xn} in X-direction: 1950 N

The safety switch foot bracket can be rotated.

Adjust the foot bracket to the required mounting position.



9.5.1

Mounting of safety switch using two screws

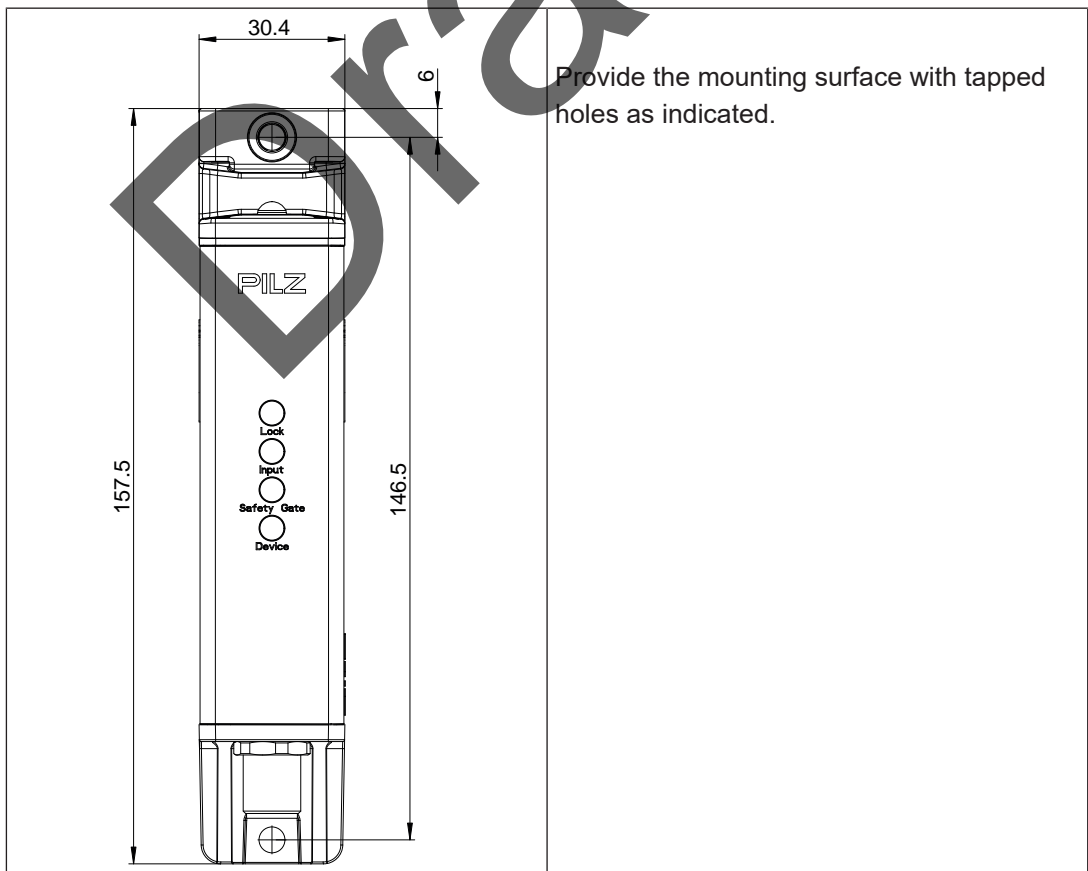

1. Attach the safety switch to the swing gate/sliding gate/flap/cover.
2. Use two M5 screws to fix the safety switch to the mounting surface.

9.6 Actuator installation

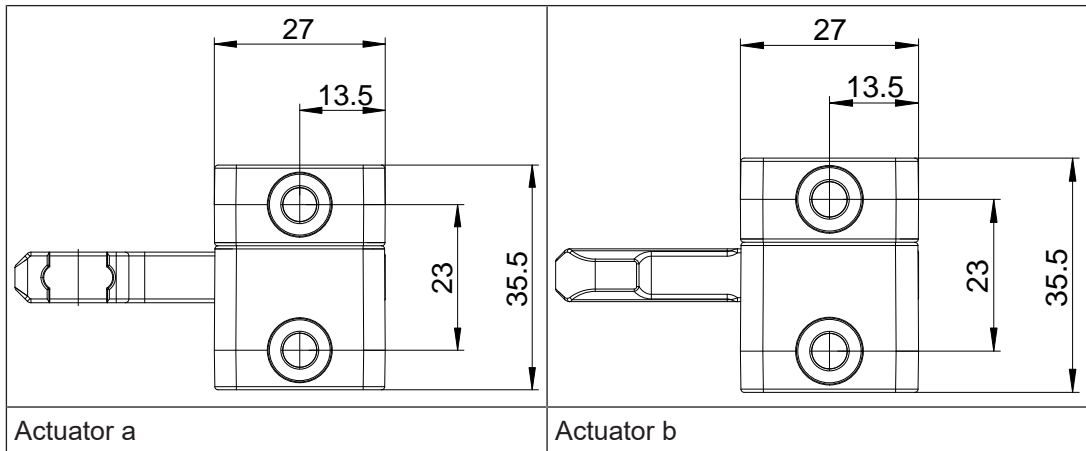

1. Attach the actuator a/b to the gate/flap/cover.
2. Use two M5 screws to fix the actuator a/b to the mounting surface.

9.7 Internal attachment: Mounting of safety switch and actuator using mounting set 1 (optional)

Depending on the application, mounting plates/mounting brackets may be required for internal attachment of the safety switch with actuator b.



NOTICE

The PSEN mIm mounting set 1 listed under accessories, material number 6K000021, is suitable for internal attachment of the safety switch parallel to the rotational axis.

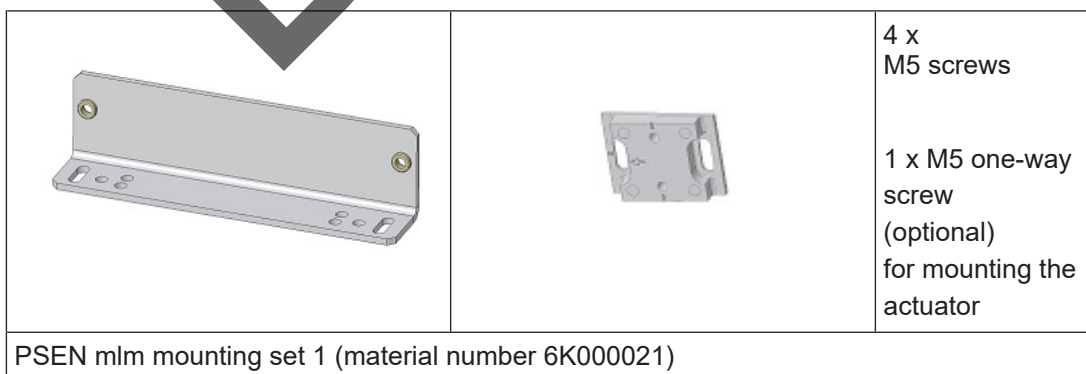

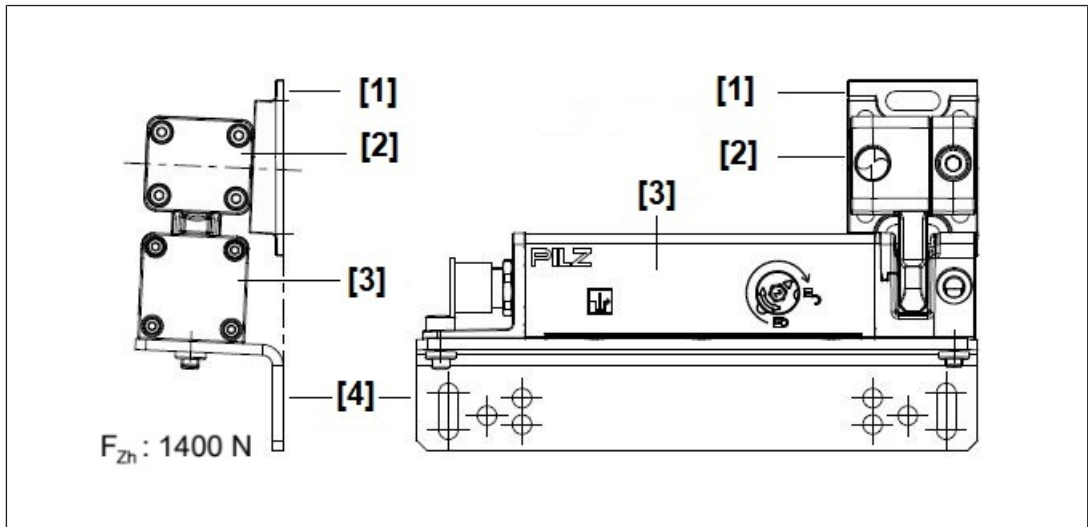

Fig.: Safety switch installed on mounting bracket and actuator on mounting plate

Legend

- [1] Mounting plate for actuator b
- [2] Actuator b (mounting using 2 screws, a one-way screw optional)
- [3] Safety switch
- [4] Bracket for safety switch (Mounting using 2 screws)
- [1] [4] PSEN mIm mounting set 1 (material number 6K000021)

Draft

Dimensions mounting bracket/mounting plate

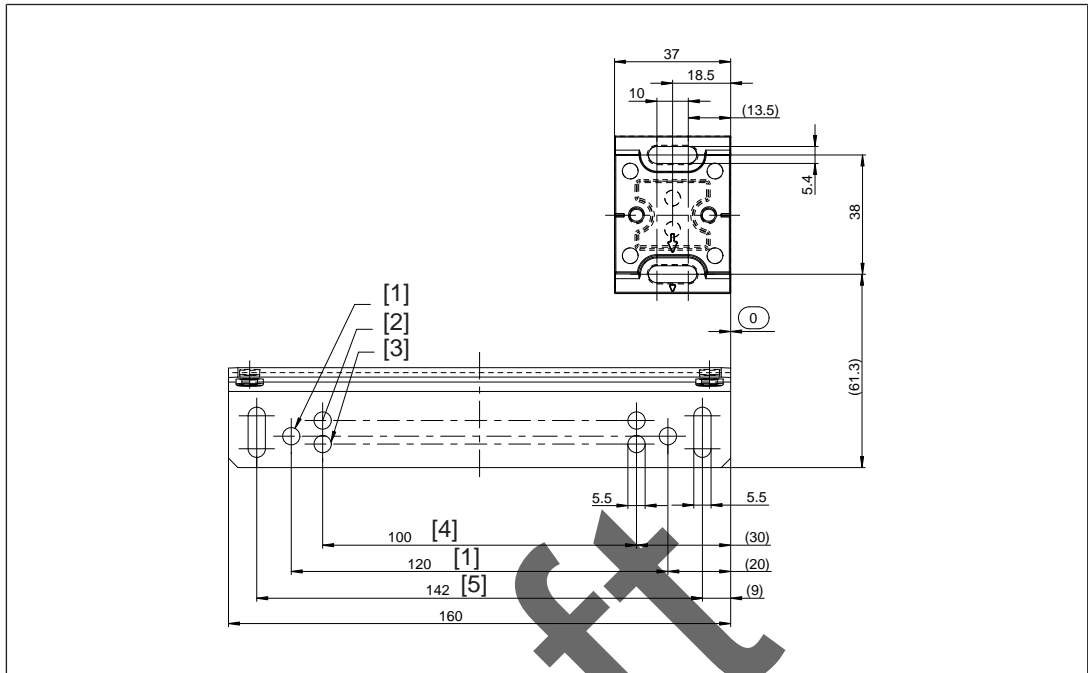



Fig.: Dimensions mounting bracket/mounting plate

Legend

- [1] Hole for screw connection to 40 mm profile
- [2] Hole for screw connection to 30 mm profile
- [3] Hole for screw connection to 45 mm profile
- [4] For 30/40 mm profile
- [5] Elongated hole for screw connection to universal profiles

9.7.1 Mounting guidelines for internally attached auxiliary release

Further information is available under [Auxiliary release](#) [ 25].

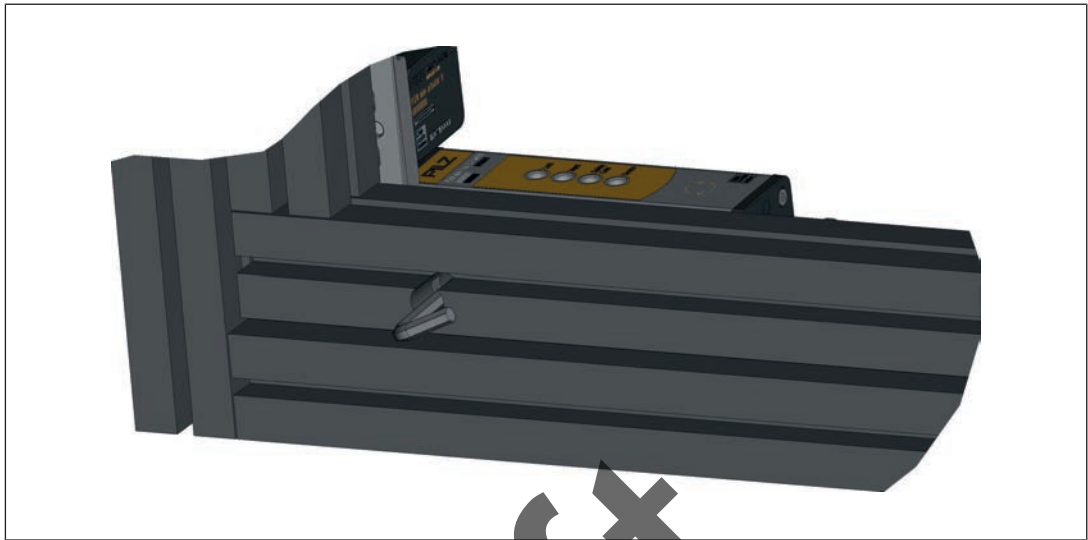

Fig.: Internally attached auxiliary release reachable with an Allen key (SW4) via a suitable opening

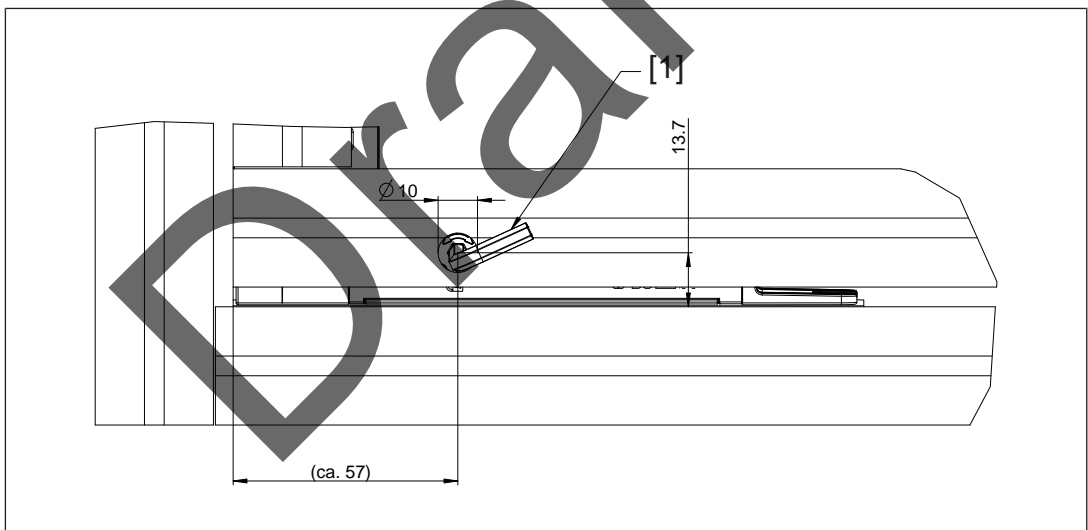







Fig.: Dimensions for reaching the auxiliary release

Legend

[1] Allen key (SW4)

10 Operation

Legend

	LED off
	LED on
	LED flashes (500 ms on, 500 ms off)
	LED flashes quickly (50 ms on, 950 ms off)
	LED flashes very quickly (25 ms on, 475 ms off)

Status indicators













- ▶ "Device" LED illuminates green: The unit is ready for operation
- ▶ "Safety Gate" LED lights up yellow: Actuator is within the response range
- ▶ "Input" LED lights up yellow: The unit is ready for operation
- ▶ "Lock" LED lights up green: Guard locking active











NOTICE



The safety functions should be checked after initial commissioning and each time the plant/machine is changed. The safety functions may only be checked by qualified personnel.

10.1 PSEN mlm in normal operation























LED status				Switch status
Device	Safety Gate	Input	Lock	
 Green	 Yellow	 Yellow	 Green	The safety switch is started
 Green	 ●	 ●	 ●	Safety gate open, actuator not detected, guard locking deactivated, safety inputs S11 and S21 are low
 Green	 ●	 Yellow	 ●	Safety gate open, actuator not detected, guard locking deactivated, safety inputs S11 and S21 are high

LED status				Switch status
Device	Safety Gate	Input	Lock	
 Green	 Yellow	 Yellow		Safety gate closed, actuator detected, guard locking deactivated, safety inputs S11 and S21 are high
 Green	 Yellow	 Yellow	 Green	Safety gate closed, actuator detected, guard locking activated, safety inputs S11 and S21 are high

Warnings

LED status				Switch status	Remedy / measure
Device	Safety Gate	Input	Lock		
Display not definitive	Display not definitive	Display not definitive	 Green	Guard locking cannot be activated/deactivated	Check the alignment of the actuator to the safety switch. Activate/deactivate guard locking again.
 Green	Display not definitive	Display not definitive	 Red	Auxiliary release	► Auxiliary release: Turn back the auxiliary release screw and then recommission the safety switch (see Recommissioning [26])

10.2 Fault indicator PSEN mlm

LED status				Switch status	Remedy / measure
Device	Safety gate	Input	Lock		
 Red				Safety outputs in fault condition	Check the wiring and switch the supply voltage off and then on again.
 Red			 Green	Safety outputs in fault condition Guard locking can be deactivated.	Check the wiring and switch the supply voltage off and then on again.
 Red			 Green	Safety outputs in fault condition Guard locking cannot be deactivated.	Change the safety switch.
 Green			 Red	Auxiliary release	▶ Auxiliary release: Turn back the auxiliary release screw and then switch the supply voltage on (see Recommissioning [26]).
 Red				Device is in error state.	Change the safety switch.
 Green	 Yellow	Display not definitive		Wrong actuator	Only use approved combinations (see Approved combinations [12])

11 Checks and maintenance

It is not necessary to perform maintenance work on the product in normal operation. Please return any faulty products to Pilz.

Regular inspection of the switch function is required to guarantee the trouble-free, long-term function.

If the interlock and guard locking system is only used rarely (opening and closing the safety gate and activating/deactivating the guard locking device), a manual function test is required.

The correct function of the device should be checked at regular intervals and after each error.

Test intervals in accordance with EN ISO 14119:

- ▶ For PI d, at least once a year

Visual inspection

- ▶ Check the safety switch and actuator for damage.
Replace the damaged safety switch and actuator.
- ▶ Check that the safety switch and actuator are firmly secured.
Tighten the fixing screws using the appropriate torque.
- ▶ Check the offset of the safety switch and actuator.
 - Max. lateral offset
 - Max. angular offset
 - Max. vertical offset
- ▶ Check that the wiring is correct.
- ▶ Remove any dirt from the safety switch and actuator.
- ▶ (Optional) Check that the seal on the auxiliary release is intact. If the seal is not intact, use varnish to seal the auxiliary release at the area marked.

Function test

- ▶ When inserted into the safety switch, the actuator is detected and the safety gate LED lights up a constant yellow.
- ▶ The guard locking device can be activated/deactivated when the safety inputs S31 and S41 are activated.
- ▶ Under these conditions there is a high signal at safety outputs 12 and 22:
 - The actuator is detected
 - Guard locking pin has successfully been activated (guard locking pin is in the locked position)

If one of these conditions is not met, the signal at the safety outputs will be low.

Series connection of the safety channels

Before commissioning and after each change, check that the safety function is guaranteed when the gates are opened. To do this, open each gate individually and check the status at the inputs on the evaluation device:

- ▶ Close all the gates.

There must be high signals at the inputs on the evaluation device (e.g. S11, S21 or I1, I2).

- ▶ Open one gate; the other gates remain closed.

There must be low signals at the inputs on the evaluation device (e.g. S11, S21 or I1, I2).

- ▶ Close the gate again.

High signals must return at the inputs on the evaluation device (e.g. S11, S21 or I1, I2).

- ▶ Repeat the test for each gate.
- ▶ If the input signals do not react as described above, check and rectify the wiring and carry out the test again.

Draft

12 Dimensions

Safety switch PSEN mlm x ba/sa 1.1/2.1/2.2

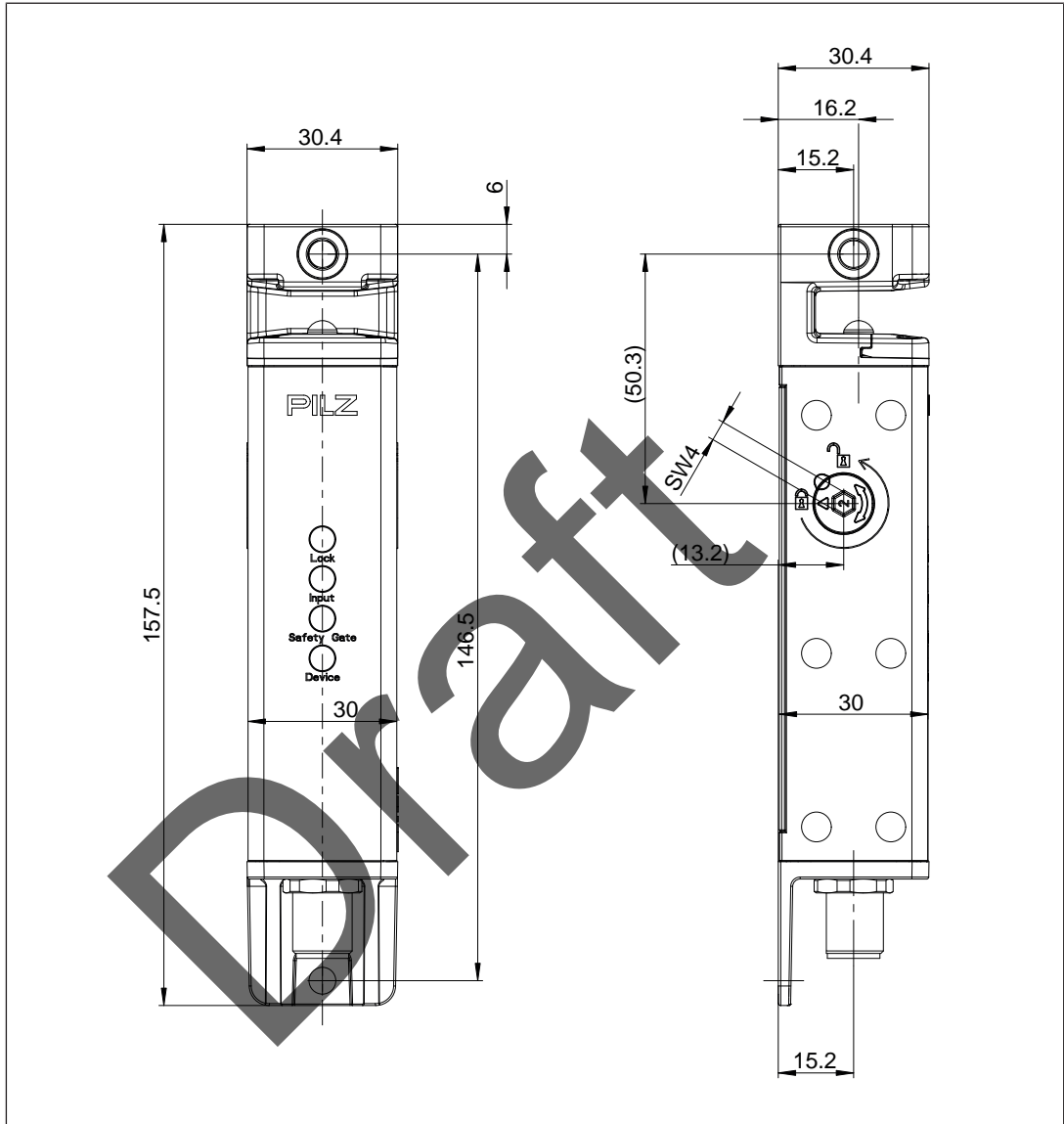

Fig.: Safety switch

Actuator a, PSEN mlm 1.1/2.1/2.2

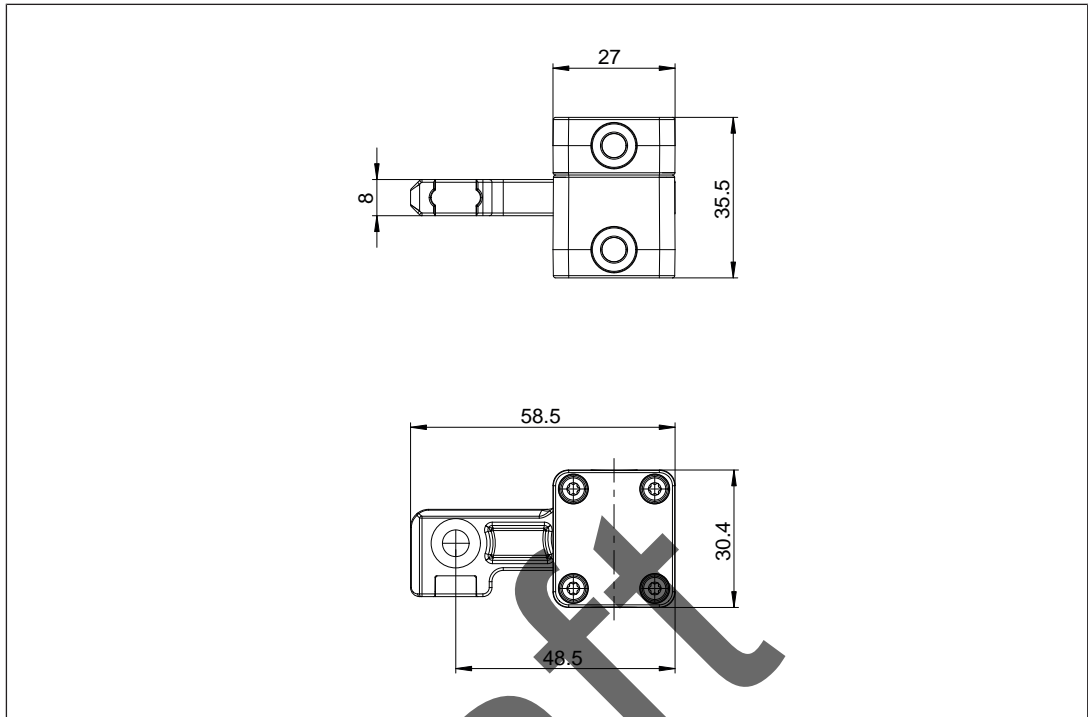

Fig.: Actuator a

Actuator b, PSEN mlm 1.1/2.1/2.2

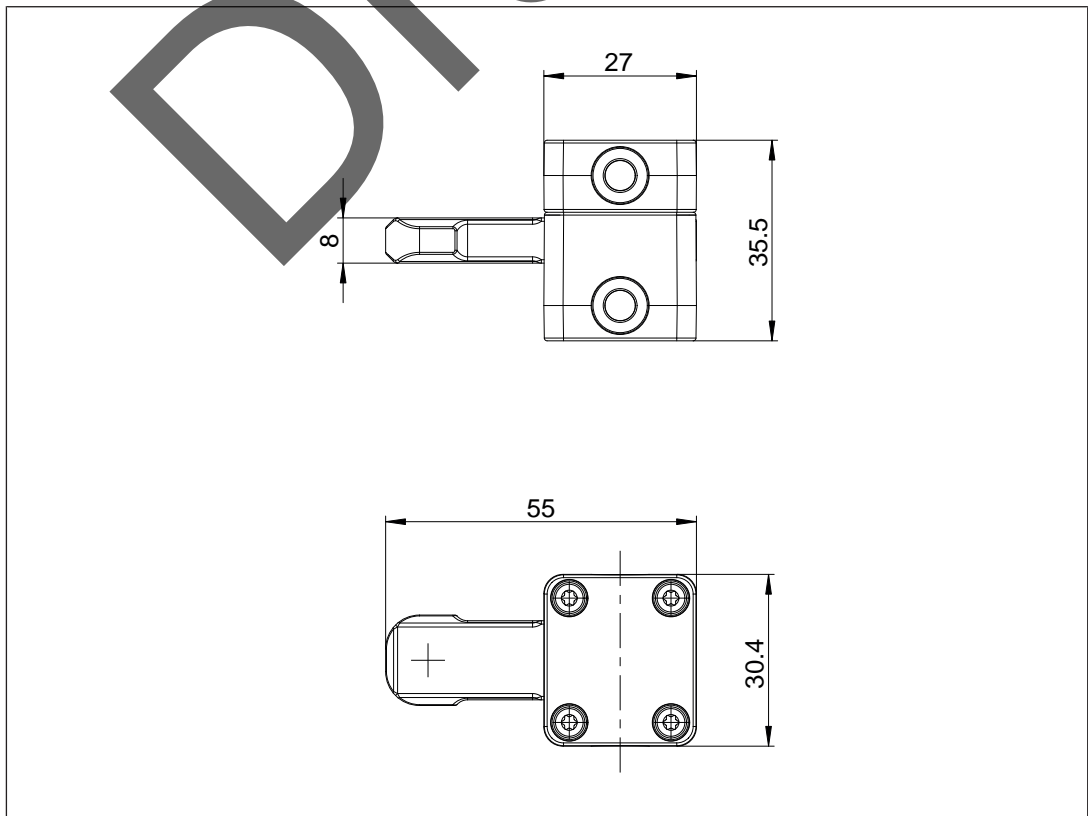

Fig.: Actuator b

13 Technical details

Safety switch PSEN mlm 1 sa with actuator a

General	6K000012	6K000013	6K000014
Certifications	CE, FCC, IC, TÜV, cULus Listed	CE, FCC, IC, TÜV, cULus Listed	CE, FCC, IC, TÜV, cULus Listed
Sensor's mode of operation	Transponders	Transponders	Transponders
Coding level in accordance with EN ISO 14119	High	High	High
Design in accordance with EN ISO 14119	4	4	4
Classification in accordance with EN 60947-5-3	PDDB	PDDB	PDDB
Pilz coding type	coded	fully coded	uniquely coded
Transponders	6K000012	6K000013	6K000014
Frequency band	127 kHz +/- 3 kHz	127 kHz +/- 3 kHz	127 kHz +/- 3 kHz
Max. transmitter output	15 mW	15 mW	15 mW
Electrical data	6K000012	6K000013	6K000014
Supply voltage			
Voltage	24 V	24 V	24 V
Kind	DC	DC	DC
Type of power supply	SELV/PELV	SELV/PELV	SELV/PELV
Voltage tolerance	-22,5 %/+20 %	-22,5 %/+20 %	-22,5 %/+20 %
Output of external power supply (DC)	0,5 W	0,5 W	0,5 W
Max. switching frequency	0,5 Hz	0,5 Hz	0,5 Hz
Max. solenoid current for t < 150 ms	1,15 A	1,15 A	1,15 A
Max. cable capacitance at the safety outputs			
No-load, PNOZ with relay contacts	40 nF	40 nF	40 nF
PNOZmulti, PNOZelog, PSS	70 nF	70 nF	70 nF
Max. inrush current impulse			
Current pulse, A1	8,4 A	8,4 A	8,4 A
Pulse duration, A1	0,0105 ms	0,0105 ms	0,0105 ms
Max. unit fuse protection in accordance with UL	1,5 A	1,5 A	1,5 A
No-load current	20 mA	20 mA	20 mA
Inputs	6K000012	6K000013	6K000014
Quantity	4	4	4
Voltage at inputs	24 V DC	24 V DC	24 V DC
Current at solenoid input	4 mA	4 mA	4 mA
Input current range	2 - 2,6 mA	2 - 2,6 mA	2 - 2,6 mA

Inputs	6K000012	6K000013	6K000014
Potential isolation between input and internal module bus voltage	No	No	No
Semiconductor outputs	6K000012	6K000013	6K000014
OSSD safety outputs	2	2	2
Signal outputs	1	1	1
Switching current per output	100 mA	100 mA	100 mA
Breaking capacity per output	2,4 W	2,4 W	2,4 W
Potential isolation from system voltage	No	No	No
Short circuit-proof	Yes	Yes	Yes
Residual current at outputs	100 µA	100 µA	100 µA
Voltage drop at OSSDs	1,25 V	1,25 V	1,25 V
Conditional rated short circuit current	100 A	100 A	100 A
Lowest operating current	1 mA	1 mA	1 mA
Utilisation category in accordance with EN 60947-1	DC-12	DC-12	DC-12
Times	6K000012	6K000013	6K000014
Max. test pulse duration, safety outputs	450 µs	450 µs	450 µs
Switch-on delay			
after UB is applied	1,2 s	1,2 s	1,2 s
Inputs typ.	40 ms	40 ms	40 ms
Inputs max.	45 ms	45 ms	45 ms
Actuator typ.	770 ms	770 ms	770 ms
Actuator max.	800 ms	800 ms	800 ms
Delay-on de-energisation			
Inputs typ.	5 ms	5 ms	5 ms
Inputs max.	5 ms	5 ms	5 ms
Risk time in accordance with EN 60947-5-3	100 ms	100 ms	100 ms
Processing time activate/deactivate guard locking	1.000 ms	1.000 ms	1.000 ms
Environmental data	6K000012	6K000013	6K000014
Ambient temperature			
in accordance with the standard	EN 60068-2-14	EN 60068-2-14	EN 60068-2-14
Temperature range	-10 - 60 °C	-10 - 60 °C	-10 - 60 °C
Storage temperature			
in accordance with the standard	EN 60068-2-1/-2	EN 60068-2-1/-2	EN 60068-2-1/-2
Temperature range	-25 - 70 °C	-25 - 70 °C	-25 - 70 °C

Environmental data	6K000012	6K000013	6K000014
Climatic suitability			
in accordance with the standard	EN 60068-2-78	EN 60068-2-78	EN 60068-2-78
Humidity	93 % r. h. at 40 °C	93 % r. h. at 40 °C	93 % r. h. at 40 °C
Max. operating height above SL	2000 m	2000 m	2000 m
EMC	EN 301489-1 V2.1.1, EN 55011: class A, EN 60947-5-2, EN 60947-5-3	EN 301489-1 V2.1.1, EN 55011: class A, EN 60947-5-2, EN 60947-5-3	EN 301489-1 V2.1.1, EN 55011: class A, EN 60947-5-2, EN 60947-5-3
Vibration			
in accordance with the standard	EN 60947-5-2	EN 60947-5-2	EN 60947-5-2
Frequency	10 - 55 Hz	10 - 55 Hz	10 - 55 Hz
Amplitude	1 mm	1 mm	1 mm
Shock stress			
in accordance with the standard	EN 60947-5-2	EN 60947-5-2	EN 60947-5-2
Number of shocks	3	3	3
Acceleration	30g	30g	30g
Duration	11 ms	11 ms	11 ms
Airgap creepage			
Overvoltage category	II	II	II
Pollution degree	2	2	2
Rated insulation voltage	75 V	75 V	75 V
Rated impulse withstand voltage	1 kV	1 kV	1 kV
Protection type			
Housing	IP65, IP67	IP65, IP67	IP65, IP67
Mechanical data	6K000012	6K000013	6K000014
Escape release available	No	No	No
Mechanical life	1,000,000 cycles	1,000,000 cycles	1,000,000 cycles
Holding force FZ _h			
in Z-direction	1500 N	1500 N	1500 N
in X-direction	1950 N	1950 N	1950 N
Holding force F1 _{Max} in accordance with ISO 14119			
in Z-direction	3000 N	3000 N	3000 N
in X-direction	3900 N	3900 N	3900 N
Latching force	11 N	11 N	11 N
Max. vertical offset	+/-0,25 mm	+/-0,25 mm	+/-0,25 mm
Max. lateral offset	+/- 1,0 mm	+/- 1,0 mm	+/- 1,0 mm
Max. angular offset around the X axis	+/-3,1 deg	+/-3,1 deg	+/-3,1 deg
Max. angular offset around the Y axis	-5/+12 deg	-5/+12 deg	-5/+12 deg

Mechanical data	6K000012	6K000013	6K000014
Max. angular offset around the Z axis	+/-2,3 deg	+/-2,3 deg	+/-2,3 deg
Max. offset in closing direction	+/-2 mm	+/-2 mm	+/-2 mm
Max. retract speed of actuator	0,3 m/s	0,3 m/s	0,3 m/s
Actuator 1	PSEN mlm actuator a	PSEN mlm actuator a	PSEN mlm actuator a
Min. distance between safety switches	35 mm	35 mm	35 mm
Connection type	M12, 12-pin male connector	M12, 12-pin male connector	M12, 12-pin male connector
Max. cable length	45 m	45 m	45 m
Material	Stainless steel, plastic, galvanised steel, die cast zinc	Stainless steel, plastic, galvanised steel, die cast zinc	Stainless steel, plastic, galvanised steel, die cast zinc
Max. fixing screws torque settings	6 - 6,5 Nm	6 - 6,5 Nm	6 - 6,5 Nm
Min. gate radius	200 mm	200 mm	200 mm
Dimensions			
Height	157,5 mm	157,5 mm	157,5 mm
Width	30,4 mm	30,4 mm	30,4 mm
Depth	30,4 mm	30,4 mm	30,4 mm
Actuator dimensions			
Height	35,5 mm	35,5 mm	35,5 mm
Width	30,4 mm	30,4 mm	30,4 mm
Depth	58,5 mm	58,5 mm	58,5 mm
Weight of safety switch	425 g	425 g	425 g
Weight of actuator	175 g	175 g	175 g
Weight	600 g	600 g	600 g

Safety switch PSEN mlm 1 sa with actuator b

General	6K000018	6K000019	6K000020
Certifications	CE, FCC, IC, TÜV, cULus Listed	CE, FCC, IC, TÜV, cULus Listed	CE, FCC, IC, TÜV, cULus Listed
Sensor's mode of operation	Transponders	Transponders	Transponders
Coding level in accordance with EN ISO 14119	High	High	High
Design in accordance with EN ISO 14119	4	4	4
Classification in accordance with EN 60947-5-3	PDDB	PDDB	PDDB
Pilz coding type	coded	fully coded	uniquely coded
Transponders	6K000018	6K000019	6K000020
Frequency band	127 kHz +/- 3 kHz	127 kHz +/- 3 kHz	127 kHz +/- 3 kHz
Max. transmitter output	15 mW	15 mW	15 mW

Electrical data	6K000018	6K000019	6K000020
Supply voltage			
Voltage	24 V	24 V	24 V
Kind	DC	DC	DC
Type of power supply	SELV/PELV	SELV/PELV	SELV/PELV
Voltage tolerance	-22,5 %/+20 %	-22,5 %/+20 %	-22,5 %/+20 %
Output of external power supply (DC)	0,5 W	0,5 W	0,5 W
Max. switching frequency	0,5 Hz	0,5 Hz	0,5 Hz
Max. solenoid current for t < 150 ms	1,15 A	1,15 A	1,15 A
Max. cable capacitance at the safety outputs			
No-load, PNOZ with relay contacts	40 nF	40 nF	40 nF
PNOZmulti, PNOZelog, PSS	70 nF	70 nF	70 nF
Max. inrush current impulse			
Current pulse, A1	8,4 A	8,4 A	8,4 A
Pulse duration, A1	0,0105 ms	0,0105 ms	0,0105 ms
Max. unit fuse protection in accordance with UL	1,5 A	1,5 A	1,5 A
No-load current	20 mA	20 mA	20 mA
Inputs	6K000018	6K000019	6K000020
Quantity	4	4	4
Voltage at inputs	24 V DC	24 V DC	24 V DC
Current at solenoid input	4 mA	4 mA	4 mA
Input current range	2 - 2,6 mA	2 - 2,6 mA	2 - 2,6 mA
Potential isolation between input and internal module bus voltage	No	No	No
Semiconductor outputs	6K000018	6K000019	6K000020
OSSD safety outputs	2	2	2
Signal outputs	1	1	1
Switching current per output	100 mA	100 mA	100 mA
Breaking capacity per output	2,4 W	2,4 W	2,4 W
Potential isolation from system voltage	No	No	No
Short circuit-proof	Yes	Yes	Yes
Residual current at outputs	100 µA	100 µA	100 µA
Voltage drop at OSSDs	1,25 V	1,25 V	1,25 V
Conditional rated short circuit current	100 A	100 A	100 A
Lowest operating current	1 mA	1 mA	1 mA

Semiconductor outputs	6K000018	6K000019	6K000020
Utilisation category in accordance with EN 60947-1	DC-12	DC-12	DC-12
Times	6K000018	6K000019	6K000020
Max. test pulse duration, safety outputs	450 µs	450 µs	450 µs
Switch-on delay			
after UB is applied	1,2 s	1,2 s	1,2 s
Inputs typ.	40 ms	40 ms	40 ms
Inputs max.	45 ms	45 ms	45 ms
Actuator typ.	770 ms	770 ms	770 ms
Actuator max.	800 ms	800 ms	800 ms
Delay-on de-energisation			
Inputs typ.	5 ms	5 ms	5 ms
Inputs max.	5 ms	5 ms	5 ms
Risk time in accordance with EN 60947-5-3	100 ms	100 ms	100 ms
Processing time activate/deactivate guard locking	1.000 ms	1.000 ms	1.000 ms
Environmental data	6K000018	6K000019	6K000020
Ambient temperature			
in accordance with the standard	EN 60068-2-14	EN 60068-2-14	EN 60068-2-14
Temperature range	-10 - 60 °C	-10 - 60 °C	-10 - 60 °C
Storage temperature			
in accordance with the standard	EN 60068-2-1/-2	EN 60068-2-1/-2	EN 60068-2-1/-2
Temperature range	-25 - 70 °C	-25 - 70 °C	-25 - 70 °C
Climatic suitability			
in accordance with the standard	EN 60068-2-78	EN 60068-2-78	EN 60068-2-78
Humidity	93 % r. h. at 40 °C	93 % r. h. at 40 °C	93 % r. h. at 40 °C
Max. operating height above SL	2000 m	2000 m	2000 m
EMC	EN 301489-1 V2.1.1, EN 55011: class A, EN 60947-5-2, EN 60947-5-3	EN 301489-1 V2.1.1, EN 55011: class A, EN 60947-5-2, EN 60947-5-3	EN 301489-1 V2.1.1, EN 55011: class A, EN 60947-5-2, EN 60947-5-3
Vibration			
in accordance with the standard	EN 60947-5-2	EN 60947-5-2	EN 60947-5-2
Frequency	10 - 55 Hz	10 - 55 Hz	10 - 55 Hz
Amplitude	1 mm	1 mm	1 mm

Environmental data	6K000018	6K000019	6K000020
Shock stress			
in accordance with the standard	EN 60947-5-2	EN 60947-5-2	EN 60947-5-2
Number of shocks	3	3	3
Acceleration	30g	30g	30g
Duration	11 ms	11 ms	11 ms
Airgap creepage			
Overvoltage category	II	II	II
Pollution degree	2	2	2
Rated insulation voltage	75 V	75 V	75 V
Rated impulse withstand voltage	1 kV	1 kV	1 kV
Protection type			
Housing	IP65, IP67	IP65, IP67	IP65, IP67
Mechanical data	6K000018	6K000019	6K000020
Escape release available	No	No	No
Mechanical life	1,000,000 cycles	1,000,000 cycles	1,000,000 cycles
Holding force FZh			
in Z-direction	1500 N	1500 N	1500 N
in X-direction	1950 N	1950 N	1950 N
Holding force F1Max in accordance with ISO 14119			
in Z-direction	3000 N	3000 N	3000 N
in X-direction	3900 N	3900 N	3900 N
Latching force	11 N	11 N	11 N
Max. vertical offset	+/-0,25 mm	+/-0,25 mm	+/-0,25 mm
Max. lateral offset	+/- 1,0 mm	+/- 1,0 mm	+/- 1,0 mm
Max. angular offset around the X axis	+/-3 deg	+/-3 deg	+/-3 deg
Max. angular offset around the Y axis	+/-12 deg	+/-12 deg	+/-12 deg
Max. angular offset around the Z axis	+/-3,2 deg	+/-3,2 deg	+/-3,2 deg
Max. offset in closing direction	+/-1 mm	+/-1 mm	+/-1 mm
Max. retract speed of actuator	0,3 m/s	0,3 m/s	0,3 m/s
Actuator 1	PSEN m1m actuator b	PSEN m1m actuator b	PSEN m1m actuator b
Min. distance between safety switches	35 mm	35 mm	35 mm
Connection type	M12, 12-pin male connector	M12, 12-pin male connector	M12, 12-pin male connector
Max. cable length	45 m	45 m	45 m
Material	Stainless steel, plastic, galvanised steel, die cast zinc	Stainless steel, plastic, galvanised steel, die cast zinc	Stainless steel, plastic, galvanised steel, die cast zinc

Mechanical data	6K000018	6K000019	6K000020
Max. fixing screws torque settings	6 - 6,5 Nm	6 - 6,5 Nm	6 - 6,5 Nm
Min. gate radius	200 mm	200 mm	200 mm
Dimensions			
Height	157,5 mm	157,5 mm	157,5 mm
Width	30,4 mm	30,4 mm	30,4 mm
Depth	30,4 mm	30,4 mm	30,4 mm
Actuator dimensions			
Height	35,5 mm	35,5 mm	35,5 mm
Width	30,4 mm	30,4 mm	30,4 mm
Depth	55 mm	55 mm	55 mm
Weight of safety switch	425 g	425 g	425 g
Weight of actuator	170 g	170 g	170 g
Weight	595 g	595 g	595 g

Where standards are undated, the 2023-08 latest editions shall apply.

Draft

14 Classification in accordance with ZVEI, CB24I

The following tables describe the classes and specific values of the product interface and the classes of interfaces compatible with it. The classification is described in the ZVEI position paper "Classification of Binary 24 V Interfaces - Functional Safety aspects covered by dynamic testing".

Inputs

Drain		Source	
Safety switch	C2	Safety control system	C2, C3

Drain parameters	Min.	Typ.	Max.
Test impulse duration	-	-	500 μ s
Input resistance	5 kOhm	-	-
Capacitive load	-	-	1 nF
Test impulse interval	2 ms	-	-

Solenoid inputs

Drain		Source	
Safety switch	C2	Safety control system	C2, C3

Drain parameters	Min.	Typ.	Max.
Test impulse duration	-	-	500 μ s
Input resistance	3 kOhm	-	-
Capacitive load	-	-	1,5 nF

Safe 1-pole SC outputs

Source		Drain	
Safety switch	C2	Evaluation device	C2

Parameter source	Min.	Typ.	Max.
test pulse duration	-	-	450 μ s
Max. ratio t_i/T	-	-	5 %
Rated current	-	-	0,1 A
Capacitive load	-	-	70 nF

15 Safety characteristic data



NOTICE

You must comply with the safety characteristic data in order to achieve the required safety level for your plant/machine.

Operating mode	EN ISO 13849-1: 2015 PL	EN ISO 13849-1: 2015 Category	EN ISO 13849-1: 2015 PFH _D [1/h]	EN ISO 13849-1: 2015 T _M [year]
1-ch. guard locking	PL d	Cat. 2	8,65E-10	20
2-ch. guard locking	PL d	Cat. 3	8,65E-10	20
2-ch. OSSD	PL d	Cat. 3	3,29E-09	20

- ▶ T_M is the maximum mission time in accordance with EN ISO 13849-1.
- ▶ The PFH_D value for the interlocking device already includes the optional maximum eight devices connected in series.
- ▶ For each guard locking safety function, the PFH_D value need only be considered once, even in a series connection.

All the units used within a safety function must be considered when calculating the safety characteristic data.



INFORMATION

A safety function's SIL/PL values are **not** identical to the SIL/PL values of the units that are used and may differ from these.



NOTICE

Be sure that you observe the mechanical life. The safety characteristic data are only valid as long as the values of mechanical life are met.

16 Supplementary data

16.1 Radio approval

USA/Canada

FC FCC ID: VT8-PSENMLM
IC: 7482A-PSENMLM

FCC/IC-Requirements:

This product complies with Part 15 of the FCC Rules and with Industry Canada licence-exempt RSS standards.

Operation is subject to the following two conditions:

- 1) this product may not cause harmful interference, and
- 2) this product must accept any interference received, including interference that may cause undesired operation.

Changes or modifications made to this product not expressly approved by Pilz may void the FCC authorization to operate this equipment.

NOTE: This equipment has been tested and found to comply with the limits for a Class A digital device, pursuant to Part 15 of the FCC Rules. These limits are designed to provide reasonable protection against harmful interference when the equipment is operated in a commercial environment. This equipment generates, uses, and can radiate radio frequency energy and, if not installed and used in accordance with the instruction manual, may cause harmful interference to radio communications. Operation of this equipment in a residential area is likely to cause harmful interference in which case the user will be required to correct the interference at his own expense.

This equipment complies with FCC and ISED radiation exposure limits set forth for an uncontrolled environment. This equipment should be installed and operated with minimum distance of 20 cm between the radiator and your body.

This transmitter must not be co-located or operating in conjunction with any other antenna or transmitter.

Le présent produit est conforme aux CNR d'Industrie Canada applicables aux appareils radio exempts de licence. L'exploitation est autorisée aux deux conditions suivantes:

- (1) le produit ne doit pas produire de brouillage, et
- (2) l'utilisateur de le produit doit accepter tout brouillage radioélectrique subi, même si le brouillage est susceptible d'en compromettre le fonctionnement.

Cet équipement est conforme aux limites d'exposition aux rayonnements ISED établies pour un environnement non contrôlé. Cet équipement doit être installé et utilisé avec un minimum de 20 cm de distance entre la source de rayonnement et votre corps.

Ce transmetteur ne doit pas être placé au même endroit ou utilisé simultanément avec un autre transmetteur ou antenne.

Draft

17 Order reference

17.1 System

Product type	Features	Order no.
PSEN mlm 1 sa 1.1 unit a	Safety guard locking device PSENmlock mini, coded, with safety switch and actuator a (side mounting, external attachment), application: small swing gates and sliding gates, as well as flaps and covers, safe guard locking for personal protection, bistable guard locking principle, 12-pin M12 male connector, series connection, automatic reset	6K000012
PSEN mlm 1 sa 1.1 unit b	Safety guard locking device PSENmlock mini, coded, with safety switch and actuator b (front mounting, internal attachment), application: small swing gates and sliding gates, as well as flaps and covers, safe guard locking for personal protection, bistable guard locking principle, 12-pin M12 male connector, series connection, automatic reset	6K000018
PSEN mlm 1 sa 1.1 switch	Safety switch, coded, for safety guard locking device PSENmlock mini, application: small swing gates and sliding gates, as well as flaps and covers, safe guard locking for personal protection, bistable guard locking principle, 12-pin M12 male connector, series connection, automatic reset	6K000004
PSEN mlm 1 sa 2.1 unit a	Safety guard locking device PSENmlock mini, fully coded, with safety switch and actuator a (side mounting, external attachment), application: small swing gates and sliding gates, as well as flaps and covers, safe guard locking for personal protection, bistable guard locking principle, 12-pin M12 male connector, series connection, automatic reset	6K000013
PSEN mlm 1 sa 2.1 unit b	Safety guard locking device PSENmlock mini, fully coded, with safety switch and actuator b (front mounting, internal attachment), application: small swing gates and sliding gates, as well as flaps and covers, safe guard locking for personal protection, bistable guard locking principle, 12-pin M12 male connector, series connection, automatic reset	6K000019
PSEN mlm 1 sa 2.1 switch	Safety switch, fully coded, for safety guard locking device PSENmlock mini, application: small swing gates and sliding gates, as well as flaps and covers, safe guard locking for personal protection, bistable guard locking principle, 12-pin M12 male connector, series connection, automatic reset	6K000005
PSEN mlm 1 sa 2.2 unit a	Safety guard locking device PSENmlock mini, uniquely coded, with safety switch and actuator a (side mounting, external attachment), application: small swing gates and sliding gates, as well as flaps and covers, safe guard locking for personal protection, bistable guard locking principle, 12-pin M12 male connector, series connection, automatic reset	6K000014
PSEN mlm 1 sa 2.2 unit b	Safety guard locking device PSENmlock mini, uniquely coded, with safety switch and actuator b (front mounting, internal attachment), application: small swing gates and sliding gates, as well as flaps and covers, safe guard locking for personal protection, bistable guard locking principle, 12-pin M12 male connector, series connection, automatic reset	6K000020

Product type	Features	Order no.
PSEN mlm 1 sa 2.2 switch	Safety switch, uniquely coded, for safety guard locking device PSENmlock mini, application: small swing gates and sliding gates, as well as flaps and covers, safe guard locking for personal protection, bistable guard locking principle, 12-pin M12 male connector, series connection, automatic reset	6K000006
PSEN mlm actuator a	Actuator a, for safety guard locking device PSENmlock mini, side mounting, external attachment	6K000007
PSEN mlm actuator b	Actuator b, for safety guard locking device PSENmlock mini, front mounting, internal attachment	6K000008

17.2 Accessories

Mounting accessories

Product type	Features	Order no.
PSEN mlm mounting set 1	Mounting set 1 (mounting bracket, mounting plate and screws) for internal attachment, for PSENmlock mini, appropriate for 30 mm, 40 mm or 45 mm standard profiles	6K000021
PSEN mlm cover set	Cover set for PSENmlock mini, protective caps for mounting holes on the safety switch and actuator	6K000022

Cable

Product type	Features	Connector X1	Connector X2	Connector X3	Order no.
PSEN cable axial M12 8-pole 3m	3 m	M12, 8-pin female connector, straight			540319
PSEN cable axial M12 8-pole 5m	5 m	M12, 8-pin female connector, straight			540320
PSEN cable axial M12 8-pole 10m	10 m	M12, 8-pin female connector, straight			540321
PSEN cable M12-8sf, 20m	20 m	M12, 8-pin female connector, straight			540333
PSEN cable axial M12 8-pole 30m	30 m	M12, 8-pin female connector, straight			540326
PSEN cable M12-8sf M12-8sm, 0.5m	0.5 m	M12, 8-pin female connector, straight	M12, 8-pin male connector, straight		540345
PSEN cable M12-8sf M12-8sm, 1m	1 m	M12, 8-pin female connector, straight	M12, 8-pin male connector, straight		540346
PSEN cable M12-8sf M12-8sm, 1.5m	1.5 m	M12, 8-pin female connector, straight	M12, 8-pin male connector, straight		540347

Product type	Features	Connector X1	Connector X2	Connector X3	Order no.
PSEN cable M12-8sf M12-8sm, 2m	2 m	M12, 8-pin fe- male con- nector, straight	M12, 8-pin male con- nector, straight		540340
PSEN cable M12-8sf M12-8sm, 5m	5 m	M12, 8-pin fe- male con- nector, straight	M12, 8-pin male con- nector, straight		540341
PSEN cable M12-8sf M12-8sm, 10m	10 m	M12, 8-pin fe- male con- nector, straight	M12, 8-pin male con- nector, straight		540342
PSEN cable M12-8sf M12-8sm, 20m	20 m	M12, 8-pin fe- male con- nector, straight	M12, 8-pin male con- nector, straight		540343
PSEN cable M12-8sf M12-8sm, 30m	30 m	M12, 8-pin fe- male con- nector, straight	M12, 8-pin male con- nector, straight		540344
PSEN cable M12-12sf 2m	2 m	M12, 12-pin fe- male con- nector, straight			570350
PSEN cable M12-12sf 3m	3 m	M12, 12-pin fe- male con- nector, straight			570351
PSEN cable M12-12sf 5m	5 m	M12, 12-pin fe- male con- nector, straight			570352
PSEN cable M12-12sf 10m	10 m	M12, 12-pin fe- male con- nector, straight			570353
PSEN cable M12-12sf 20m	20 m	M12, 12-pin fe- male con- nector, straight			570354
PSEN cable M12-12sf 30m	30 m	M12, 12-pin fe- male con- nector, straight			570355
PSEN cable M12-12sf 50m	50 m	M12, 12-pin fe- male con- nector, straight			570356
PSEN cable M12-12sf/ M12-12sm 1m	1 m	M12, 12-pin fe- male con- nector, straight	M12, 12-pin male con- nector, straight		570357
PSEN cable M12-12sf/ M12-12sm 2m	2 m	M12, 12-pin fe- male con- nector, straight	M12, 12-pin male con- nector, straight		570358
PSEN cable M12-12sf/ M12-12sm 3m	3 m	M12, 12-pin fe- male con- nector, straight	M12, 12-pin male con- nector, straight		570359
PSEN cable M12-12sf/ M12-12sm 5m	5 m	M12, 12-pin fe- male con- nector, straight	M12, 12-pin male con- nector, straight		570360

Product type	Features	Connector X1	Connector X2	Connector X3	Order no.
PSEN cable M12-12sf/ M12-12sm 10m	10 m	M12, 12-pin female connector, straight	M12, 12-pin male connector, straight		570361
PSEN cable M12-12sf/ M12-12sm 20m	20 m	M12, 12-pin female connector, straight	M12, 12-pin male connector, straight		570362

Series connection

Product type	Features	Connector X1	Connector X2	Connector X3	Order no.
PSEN ml Y junction M12		M12, 8-pin male connector	M12, 8-pin female connector	M12, 12-pin female connector	570486
PSEN ml end adapter		M12, 12-pin female connector	M12, 8-pin male connector		570487

Draft

18 **EC declaration of conformity**

This product/these products meet the requirements of the directive 2006/42/EC on machinery of the European Parliament and of the Council. The complete EC Declaration of Conformity is available on the Internet at www.pilz.com/downloads.

Representative: Pilz GmbH & Co. KG, Felix-Wankel-Str. 2, 73760 Ostfildern, Germany

Draft

19 **EC declaration of conformity**

This product/these products meet(s) the requirements of the following directives of the European Parliament and of the Council.

- ▶ 2014/53/EU on radio equipment

The complete EC Declaration of Conformity is available on the Internet at www.pilz.com/downloads.

Representative: Pilz GmbH & Co. KG, Felix-Wankel-Str. 2, 73760 Ostfildern, Germany

Draft

20

UKCA-Declaration of Conformity

This product(s) complies with following UK legislation: Supply of Machinery (Safety) Regulation 2008.

The complete UKCA Declaration of Conformity is available on the Internet at www.pilz.com/downloads.

Representative: Pilz Automation Technology, Pilz House, Little Colliers Field, Corby, Northamptonshire, NN18 8TJ United Kingdom, eMail: mail@pilz.co.uk

Draft

Support

Technical support is available from Pilz round the clock.

Americas

Brazil

+55 11 97569-2804

Canada

+1 888 315 7459

Mexico

+52 55 5572 1300

USA (toll-free)

+1 877-PILZUSA (745-9872)

Asia

China

+86 400-088-3566

Japan

+81 45 471-2281

South Korea

+82 31 778 3300

Australia and Oceania

Australia

+61 3 95600621

New Zealand

+64 9 6345350

Europe

Austria

+43 1 7986263-444

Belgium, Luxembourg

+32 9 3217570

France

+33 3 88104003

Germany

+49 711 3409-444

Ireland

+353 21 4804983

Italy, Malta

+39 0362 1826711

Scandinavia

+45 74436332

Spain

+34 938497433

Switzerland

+41 62 88979-32

The Netherlands

+31 347 320477

Türkiye

+90 216 5775552

United Kingdom

+44 1536 462203

You can reach our international hotline on:

+49 711 3409-222

support@pilz.com

Pilz develops environmentally-friendly products using ecological materials and energy-saving technologies. Offices and production facilities are ecologically designed, environmentally-aware and energy-saving. So Pilz offers sustainability, plus the security of using energy-efficient products and environmentally-friendly solutions.



We are represented internationally. Please refer to our homepage www.pilz.com for further details or contact our headquarters.

Headquarters: Pilz GmbH & Co. KG, Felix-Wankel-Straße 2, 73760 Ostfildern, Germany
Telephone: +49 711 3409-0, E-Mail: info@pilz.com, Internet: www.pilz.com

PILZ
THE SPIRIT OF SAFETY