



**PSEN cs5.1p**

PSEN sensor technology



**pilz**

This document is the original document.

All rights to this documentation are reserved by Pilz GmbH & Co. KG. Copies may be made for internal purposes. Suggestions and comments for improving this documentation will be gratefully received.

Pilz®, PIT®, PMI®, PNOZ®, Primo®, PSEN®, PSS®, PVIS®, SafetyBUS p®, SafetyEYE®, SafetyNET p®, the spirit of safety® are registered and protected trademarks of Pilz GmbH & Co. KG in some countries.



SD means Secure Digital

<b>Introduction</b>	<b>5</b>
Validity of documentation	5
Using the documentation	5
Definition of symbols	5
<b>Safety</b>	<b>6</b>
Intended use	6
Safety regulations	6
Safety assessment	6
Use of qualified personnel	7
Warranty and liability	7
Disposal	7
For your safety	8
<b>Unit features</b>	<b>8</b>
<b>Function description</b>	<b>8</b>
Block diagram	9
Operating distances	10
Lateral offset when aligning to the triangle or square marking	11
Vertical offset when aligning to the triangle or square marking	12
Lateral and vertical offset when aligning to the semicircle marking	13
<b>Wiring</b>	<b>14</b>
Pin assignment, connector and cable	14
<b>Connection to evaluation devices</b>	<b>15</b>
<b>Teaching in the actuator</b>	<b>18</b>
<b>Installation</b>	<b>18</b>
<b>Adjustment</b>	<b>21</b>
<b>Operation</b>	<b>21</b>
Normal mode	22
Error display	22
<b>Dimensions in mm</b>	<b>23</b>
<b>Technical details</b>	<b>24</b>
Safety characteristic data	27
<b>Supplementary data</b>	<b>27</b>
Radio approval	27
<b>Order reference</b>	<b>27</b>
System	27

---

Accessories	28
<b>EC declaration of conformity</b>	<b>28</b>

## Introduction

### Validity of documentation

This documentation is valid for the product PSEN cs5.1p. It is valid until new documentation is published.

This operating manual explains the function and operation, describes the installation and provides guidelines on how to connect the product.

### Using the documentation

This document is intended for instruction. Only install and commission the product if you have read and understood this document. The document should be retained for future reference.

### Definition of symbols

Information that is particularly important is identified as follows:



#### **DANGER!**

This warning must be heeded! It warns of a hazardous situation that poses an immediate threat of serious injury and death and indicates preventive measures that can be taken.



#### **WARNING!**

This warning must be heeded! It warns of a hazardous situation that could lead to serious injury and death and indicates preventive measures that can be taken.



#### **CAUTION!**

This refers to a hazard that can lead to a less serious or minor injury plus material damage, and also provides information on preventive measures that can be taken.



#### **NOTICE**

This describes a situation in which the product or devices could be damaged and also provides information on preventive measures that can be taken. It also highlights areas within the text that are of particular importance.

**INFORMATION**

This gives advice on applications and provides information on special features.

**Safety****Intended use**

The safety functions of the safety switch are:

- ▶ safe detection of the presence of the actuator
- ▶ 2 safety inputs for series connection of multiple safety sensors
- ▶ 2 safety outputs, each of which supply a high signal when the corresponding input is high and the actuator is in the switch's response range.

The safety switch meets the requirements in accordance with:

- ▶ EN 60947-5-3 with the actuator PSEN cs5.1 : PDDB
- ▶ EN 62061: SIL CL 3
- ▶ EN ISO 13849-1: PL eCat. 4
- ▶ EN ISO 14119

The safety switch may only be used with the corresponding actuator PSEN cs5.1.

The safety level PL e (Cat. 4 )/SIL CL 3 is only achieved if

- ▶ the safety outputs use 2-channel processing.

The following is deemed improper use in particular:

- ▶ Any component, technical or electrical modification to the product
- ▶ Use of the product outside the areas described in this manual
- ▶ Use of the product outside the technical details (see chapter entitled "Technical Details").

**NOTICE**

**EMC-compliant electrical installation**

The product is designed for use in an industrial environment. The product may cause interference if installed in other environments. If installed in other environments, measures should be taken to comply with the applicable standards and directives for the respective installation site with regard to interference.

**Safety regulations****Safety assessment**

Before using a unit it is necessary to perform a safety assessment in accordance with the Machinery Directive.

Functional safety is guaranteed for the product as a single component. However, this does not guarantee the functional safety of the overall plant/machine. In order to achieve the required safety level for the overall plant/machine, define the safety requirements for the plant/machine and then define how these must be implemented from a technical and organisational standpoint.

### **Use of qualified personnel**

The products may only be assembled, installed, programmed, commissioned, operated, maintained and decommissioned by competent persons.

A competent person is someone who, because of their training, experience and current professional activity, has the specialist knowledge required to test, assess and operate the work equipment, devices, systems, plant and machinery in accordance with the general standards and guidelines for safety technology.

It is the company's responsibility only to employ personnel who:

- ▶ Are familiar with the basic regulations concerning health and safety / accident prevention
- ▶ Have read and understood the information provided in this description under "Safety"
- ▶ And have a good knowledge of the generic and specialist standards applicable to the specific application.

### **Warranty and liability**

All claims to warranty and liability will be rendered invalid if

- ▶ The product was used contrary to the purpose for which it is intended
- ▶ Damage can be attributed to not having followed the guidelines in the manual
- ▶ Operating personnel are not suitably qualified
- ▶ Any type of modification has been made (e.g. exchanging components on the PCB boards, soldering work etc.).

### **Disposal**

- ▶ In safety-related applications, please comply with the mission time  $T_M$  in the safety-related characteristic data.
- ▶ When decommissioning, please comply with local regulations regarding the disposal of electronic devices (e.g. Electrical and Electronic Equipment Act).

**For your safety****DANGER!**

Risk to life due to manipulation / defeat of the safeguard

If replacement actuators are obtained, these must be installed as described in the chapter entitled [Installation](#) [18].

If replacement actuators are used manipulatively or the function of the safeguard is defeated, there is a risk to life when operating the plant or machine! This must be considered in the operator's hazard assessment and the operator must define appropriate measures to exclude manipulation.

- ▶ Do not remove the protective cap until you are just about to connect the unit. This will prevent potential contamination.

**Unit features**

- ▶ Transponder technology for presence detection (safety function)
- ▶ Coding: coded (measure to minimise defeat possibilities in accordance with ISO 14119)
- ▶ Dual-channel operation
- ▶ 2 safety inputs for series connection of multiple safety switches
- ▶ 2 safety outputs
- ▶ 1 signal output
- ▶ LED display for:
  - State of the actuator
  - State of the inputs
  - Supply voltage/fault
- ▶ 4 actuation directions, each with 3 approach directions (see [Explanation of markings](#) [10])
  - Square marking for normal operating distance
  - Triangle marking for short operating distance
  - 2 semicircle markings for a lateral approach. Please note the Lateral and vertical offset with the lateral approach to the semicircle marking.

The guaranteed safe operating distances only apply when the actuator approaches the switch vertically. With the other approach directions, the operating distances may sometimes be considerably larger (particularly when approaching the semicircle).

**Function description**

The safety outputs may have a high or low signal, depending on the position of the actuator and the signal status of the safety inputs.



**Electrical states of the safety inputs and outputs (when switch is ready for operation: DEVICE LED is green):**

Actuator in the re- sponse range	Safety input S11	Safety input S21	Safety out- put 12	Safety out- put 22	Signal out- put Y32
Yes	High	High	High	High	High
Yes	Low	Low	Low	Low	High
No	X	X	Low	Low	Low
Yes	High	Low	High	Low	High
Yes	Low	High	Low	High	High

x: High or low signal

**Feasibility monitoring for safety inputs S11 and S21**

- ▶ If one safety input switches from high to low, while the other safety input remains high, an unequal status is displayed: **Input LED has quick yellow flashes and Device LED flashes red**
- ▶ If this safety input switches back from low to high, while the other safety input remains high, a feasibility error is displayed and a partial operation lock is triggered: **Input LED flashes yellow and Device LED flashes red**

A switch to a high signal will only lead to normal switch operation if both inputs had a low signal. From this moment on, the switch to high may occur (partial operation lock see [Error display \[📖 22\]](#)).

**Block diagram**

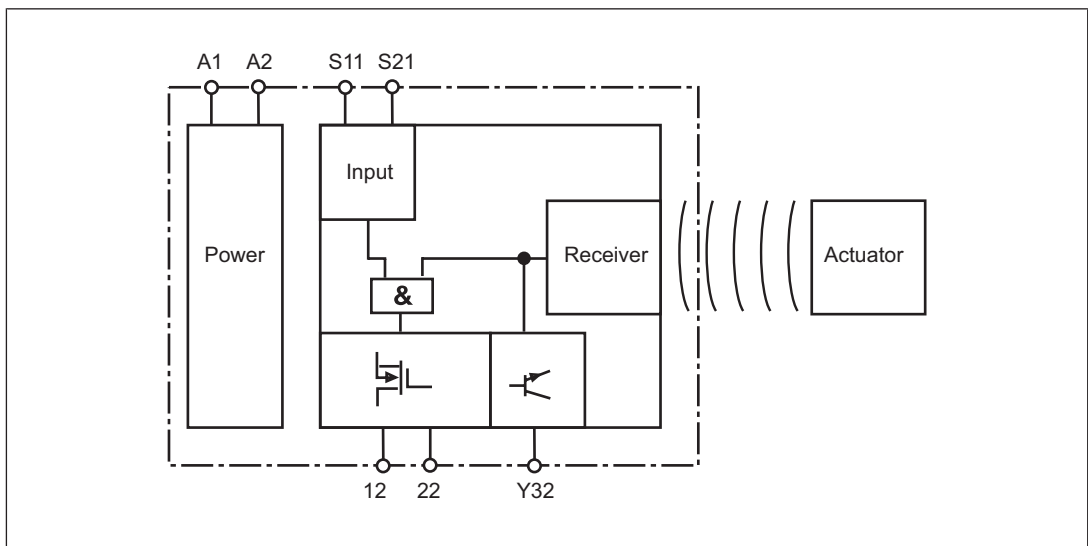

**Operating distances**

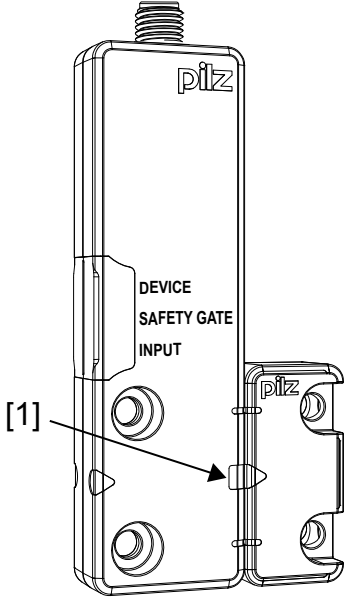
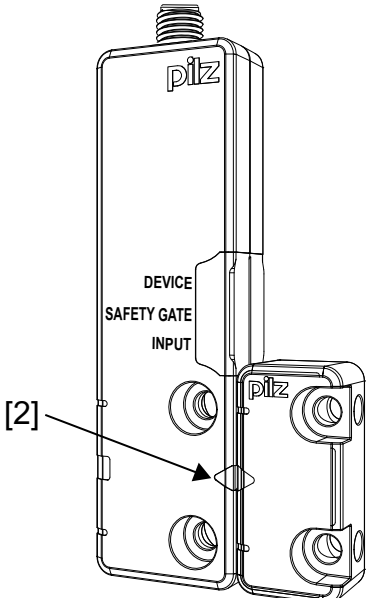
Alignment of the actuator	Operating distances
<p>[1] Actuator aligned to the square marking on the switch</p> 	<p> <math>S_{ao}</math> Assured operating distance: 8 mm  <math>S_o</math> Typical operating distance: 11 mm  <math>S_r</math> Typical release distance: 14 mm  <math>S_{ar}</math> Assured release distance: 20 mm                 </p>
<p>[2] Actuator aligned to the triangle marking on the switch</p> 	<p> <math>S_{ao}</math> Assured operating distance: 4 mm  <math>S_o</math> Typical operating distance: 5 mm  <math>S_r</math> Typical release distance: 8 mm  <math>S_{ar}</math> Assured release distance: 12 mm                 </p>

[3] Actuator aligned to the semicircle marking on the switch

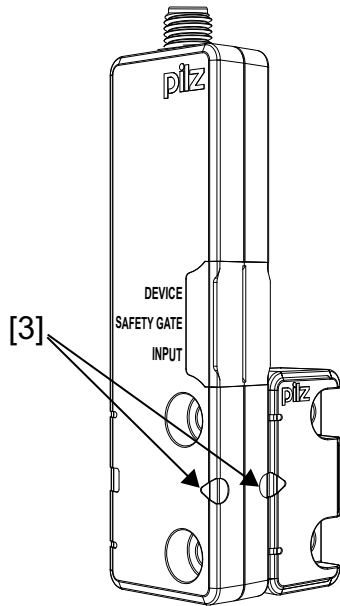

$S_{ao}$  Assured operating distance: 6 mm  
 $S_o$  Typical operating distance: 9 mm  
 $S_r$  Typical release distance: 11 mm  
 $S_{ar}$  Assured release distance: 19 mm

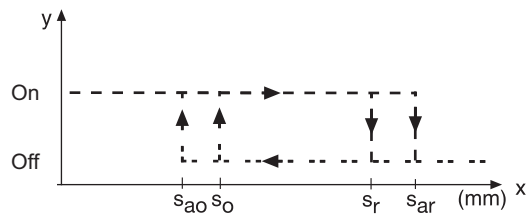

**Lateral offset when aligning to the triangle or square marking**

	Alignment 1: Actuator aligned to the square marking on the switch	Alignment 2: Actuator aligned to the triangle marking on the switch

**Legend:**

- ▶ [1]: Hysteresis
- ▶ [2]: Typical operating distance  $S_o$
- ▶ [3]: Typical release distance  $S_r$
- ▶ [4]: Offset in mm
- ▶ [5]: Operating distance in mm
- ▶ [6]: Response range
- ▶ [7]: Status of LED

**Vertical offset when aligning to the triangle or square marking**

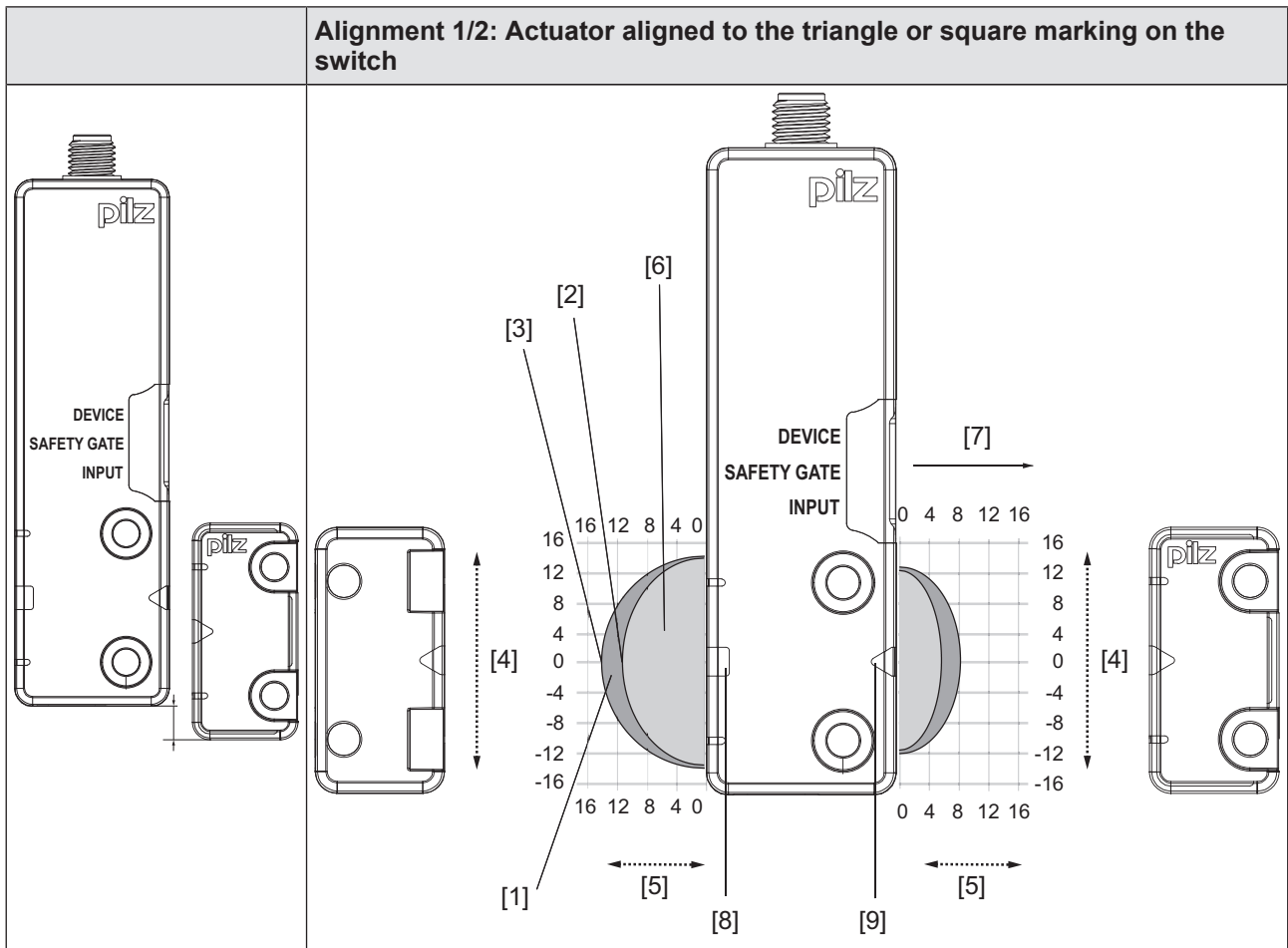

**Legend**

- ▶ [1]: Hysteresis
- ▶ [2]: Typical operating distance  $S_o$
- ▶ [3]: Typical release distance  $S_r$
- ▶ [4]: Offset in mm
- ▶ [5]: Operating distance in mm
- ▶ [6]: Response range
- ▶ [7]: Status of LED
- ▶ [8]: Square marking

- ▶ [9]: Triangle marking

**Lateral and vertical offset when aligning to the semicircle marking**

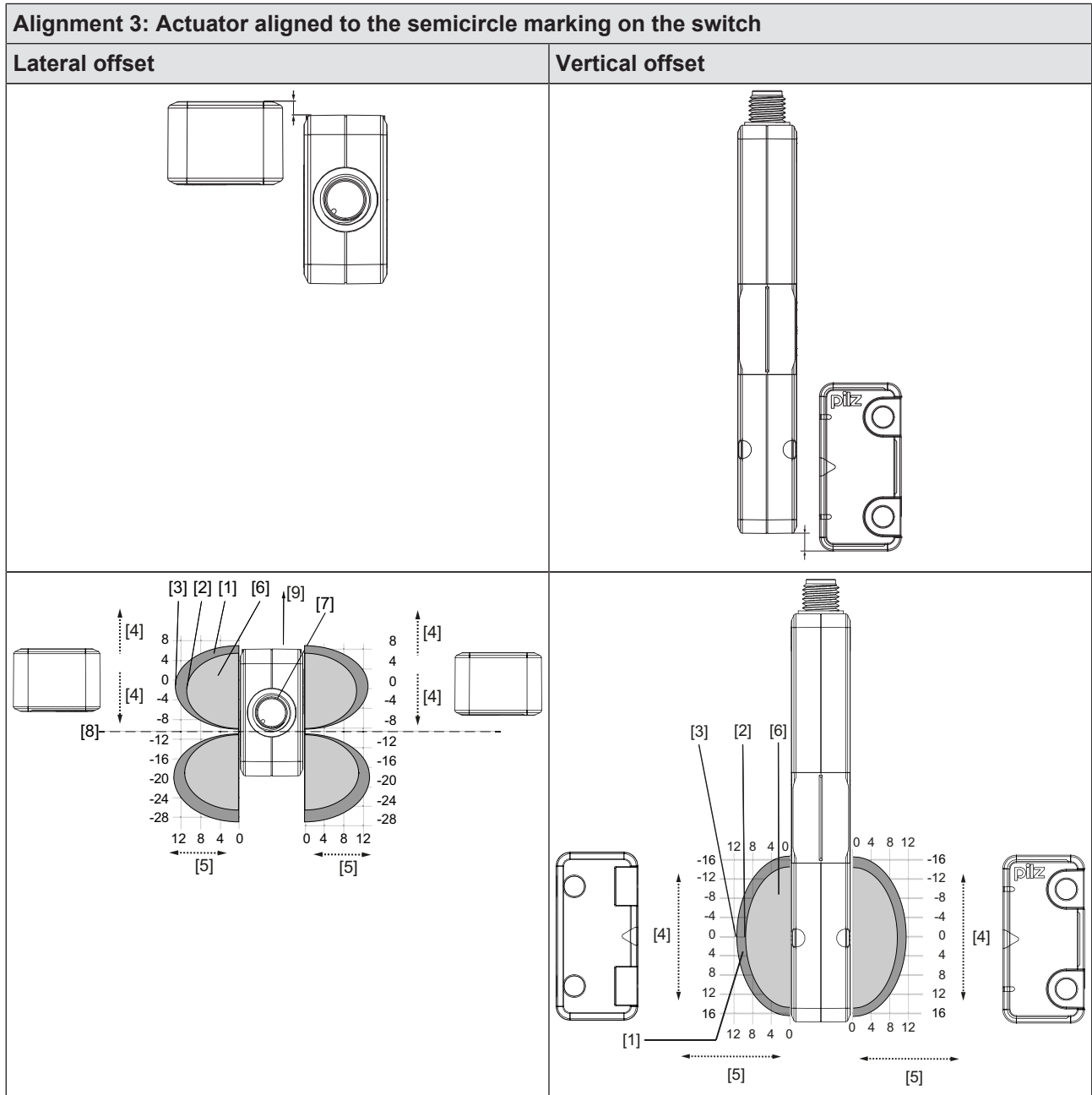

Two actuators are shown in the diagrams because the sensor can be approached from both sides at the semicircle marking. However, only one actuator can be used.

**Legend**

- ▶ [1]: Hysteresis
- ▶ [2]: Typical operating distance  $S_o$
- ▶ [3]: Typical release distance  $S_r$
- ▶ [4]: Offset in mm
- ▶ [5]: Operating distance in mm

- ▶ [6]: Response range
- ▶ [7]: Connector on the sensor
- ▶ [8]: Limit of response range, position of gate hinge
- ▶ [9]: Status of LED

## Wiring

Please note:

- ▶ Information given in the "Technical details" must be followed.
- ▶ The max. cable length  $l_{\max}$  in the input circuit is calculated from
  - the max. cable capacitance at the safety outputs (see [Technical data](#) [ 24]).
  - the minimum permitted supply voltage at the sensor (19.2 V).
- ▶ The power supply must meet the regulations for extra low voltages with protective separation (SELV, PELV).
- ▶ The inputs and outputs of the safety switch must have a protective separation to voltages over 60 VDC.



### INFORMATION

Only use safety relays with a 24 VDC supply voltage. Safety relays with universal power supply or in AC device versions have internal potential isolation and are not suitable as evaluation devices.



### CAUTION!

Do not connect the signal output to 0 V!

If the signal output Y32 is connected to 0 V, the safety switch may be damaged as a result. Connect the signal output Y32 to a consumer, e.g. to the input on a control system, or leave the signal output unconnected.

- ▶ The supply voltage to the safety switch must be protected with a 2 A to 4 A quick-acting fuse.
- ▶ Ensure the EMC requirements of IEC 60204-1 are met.
- ▶ When connecting in series, make sure you comply with the wiring technology requirements (DIN EN 60204-1) and manipulation protection requirements (EN ISO 14119).

### Pin assignment, connector and cable

	8 pin M8/M12 connector
--	------------------------

PIN	Pin designation	Function	Wire colour
1	S21	Input, channel 2	white
2	A1	+24 VUB	brown
3	12	Output, channel1	Green
4	22	Output, channel2	yellow
5	Y32	Signal output	grey
6	S11	Input, channel 1	Pink
7	A2	0 V UB	blue
8	-	Do not connect	red

The wire colour also applies for the cable available from Pilz as an accessory.

### Connection to evaluation devices

Make sure that the selected evaluation device has the following properties:

- ▶ Dual-channel with feasibility monitoring
- ▶ OSSD signals are evaluated

#### Connection diagram, single connection

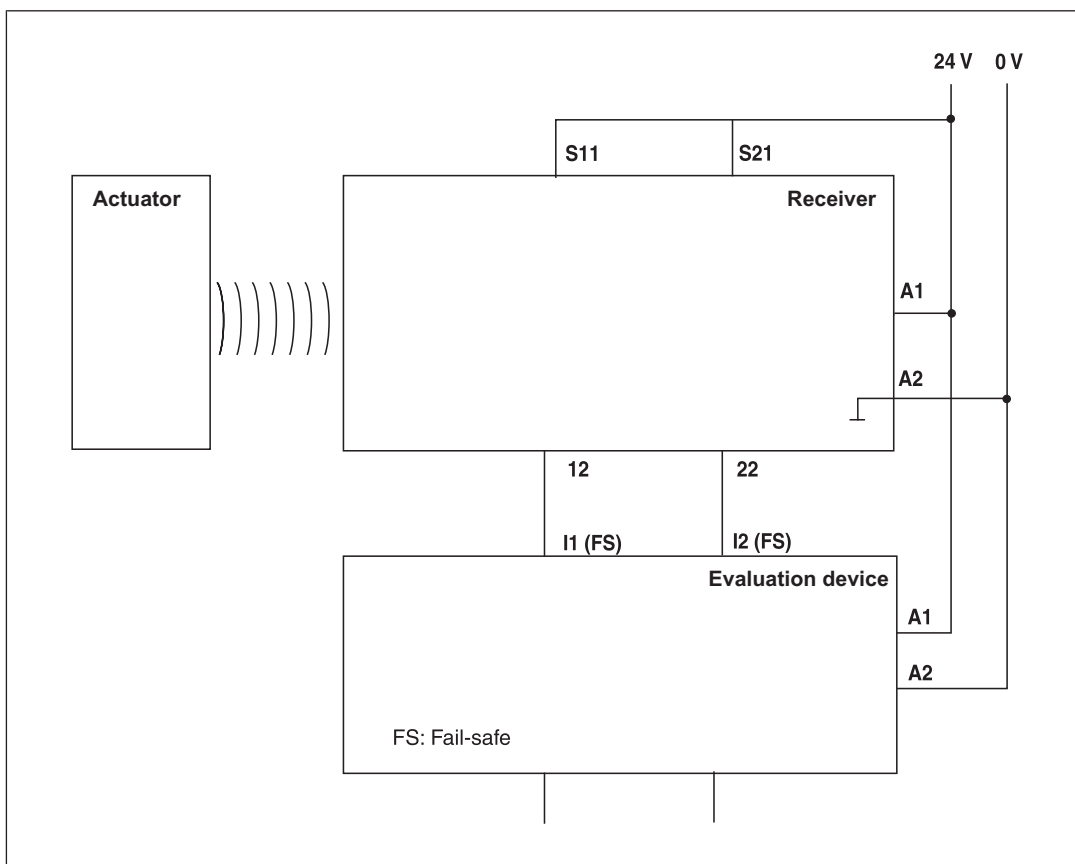

Connection diagram, series connection

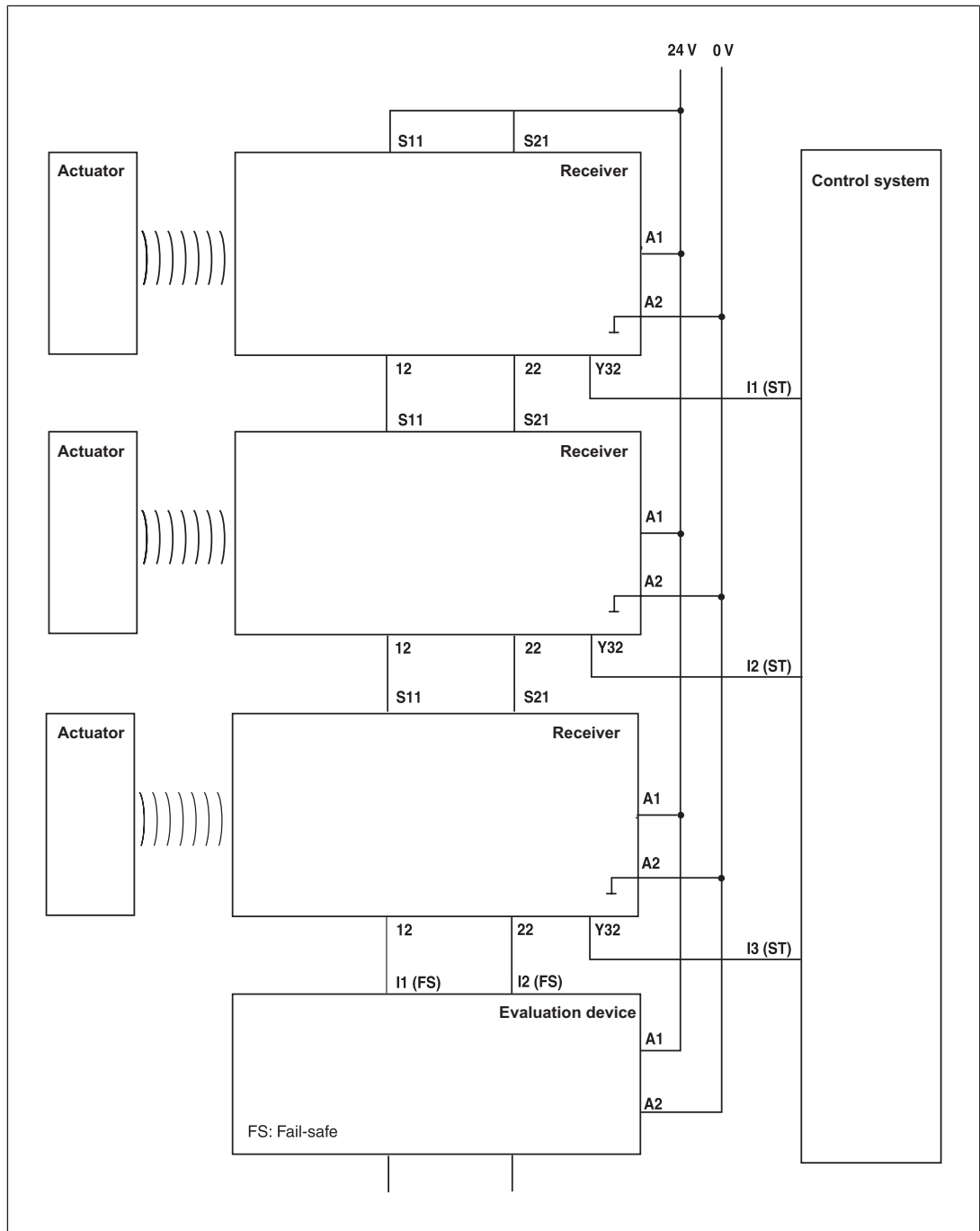



**CAUTION!**

Extension of delay-on de-energisation

When several (n) devices are connected in series, the delay-on de-energisation time adds with the number of interconnected safety switches.

The max. delay-on de-energisation is made up of the risk time (see [Technical details](#) [ 24])

+ (n-1) x max. delay-on de-energisation of the inputs

+ max. delay-on de-energisation of the evaluation device

The safety sensors PSENcode are also suitable for series connection with other sensors. The series connection of maximum 32 sensors PSENcs 5.x and PSEN 6.x is approved for SIL CL 3 .

In practice, the maximum possible number will be limited by the following parameters, among others:

- ▶ The required SIL level (e.g. SIL CL 3),
- ▶ The required Performance Level (e.g. Cat. 4 / PL e),
- ▶ The maximum delay or risk time permitted by the application.

It's important to ensure there is sufficient supply voltage, taking inrush currents and fusing into consideration.

**Connection to Pilz evaluation devices**

The safety switch PSEN cs5.1p can be connected to Pilz evaluation devices, for example. Make sure that an evaluation device is selected that can evaluate OSSD signals through two channels.

Suitable Pilz evaluation devices are, for example:

- ▶ PNOZelog for safety gate monitoring
- ▶ PNOZpower for safety gate monitoring
- ▶ PNOZsigma for safety gate monitoring
- ▶ PNOZ X for safety gate monitoring
- ▶ PNOZmulti for safety gate monitoring  
Configure the switch in the PNOZmulti Configurator with switch type 3.
- ▶ PSS for safety gate monitoring with standard function block SB064, SB066 or FS\_Safety Gate

The correct connection to the respective evaluation device is described in the instructions for the evaluation device. Make sure that the connection is made in accordance with the specifications in the instructions for the selected evaluation device.

The connections to two evaluation devices are shown on the following pages, by way of example:

- ▶ PNOZ s3 and
- ▶ PNOZmulti

### PNOZ s3

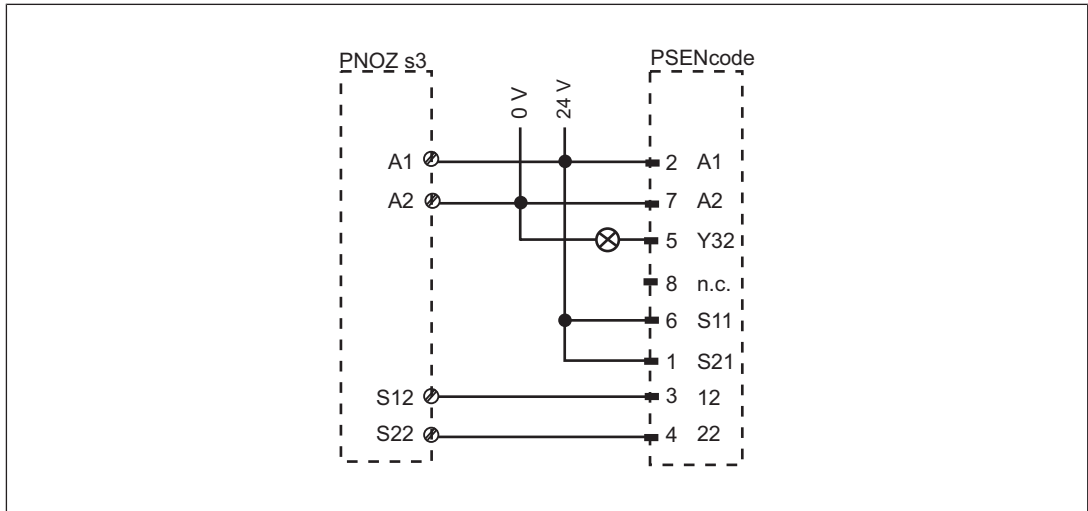

### PNOZmulti

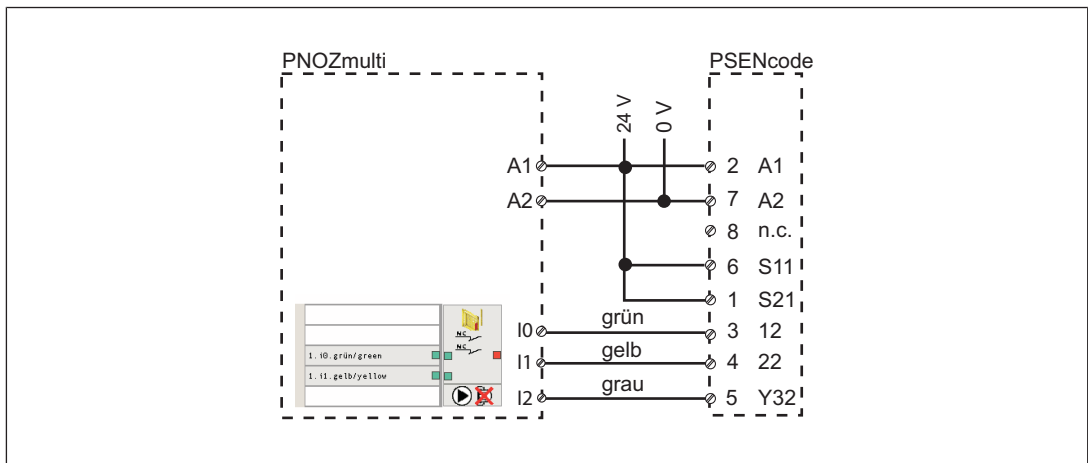

#### Legend:

I0	Input OSSD
I1	Input OSSD
I2	Signal input

### Teaching in the actuator

Any Pilz actuator (PSEN cs5.1) is detected as soon as it is brought into the response range.

### Installation



#### CAUTION!

The unit's properties may be affected if installed in an environment containing electrically or magnetically conductive material. Please check the operating distances and the assured release distance.

- ▶ The safety switch and actuator should be installed opposite each other in parallel. Make sure that the actuator is aligned to the marking on the sensor that guarantees the operating distance required by the plant design (see [Operating distances](#) [📖 10]).
- ▶ Safety switches and actuators should only be secured using M4 screws with a flat head (e.g. M4 cheese-head or pan head screws).
- ▶ Torque setting: Note the stated max. torque in the [Technical details](#) [📖 24].
- ▶ The distance between two safety switches must be maintained (see [Technical Details](#) [📖 24]).
- ▶ If using angled connector plugs, note the defined angle of the cable routing.
- ▶ When installing make sure you comply with the requirements of EN ISO 14119.
- ▶ Make sure that the safety switch and actuator cannot be used as an end stop.
- ▶ The actuator should be protected from unauthorised removal and from contamination. Close the mounting holes using the seals provided (see diagrams). The use of seals should be regarded as equivalent to using permanent fastenings in accordance with Clause 7.2c of EN ISO 14119.

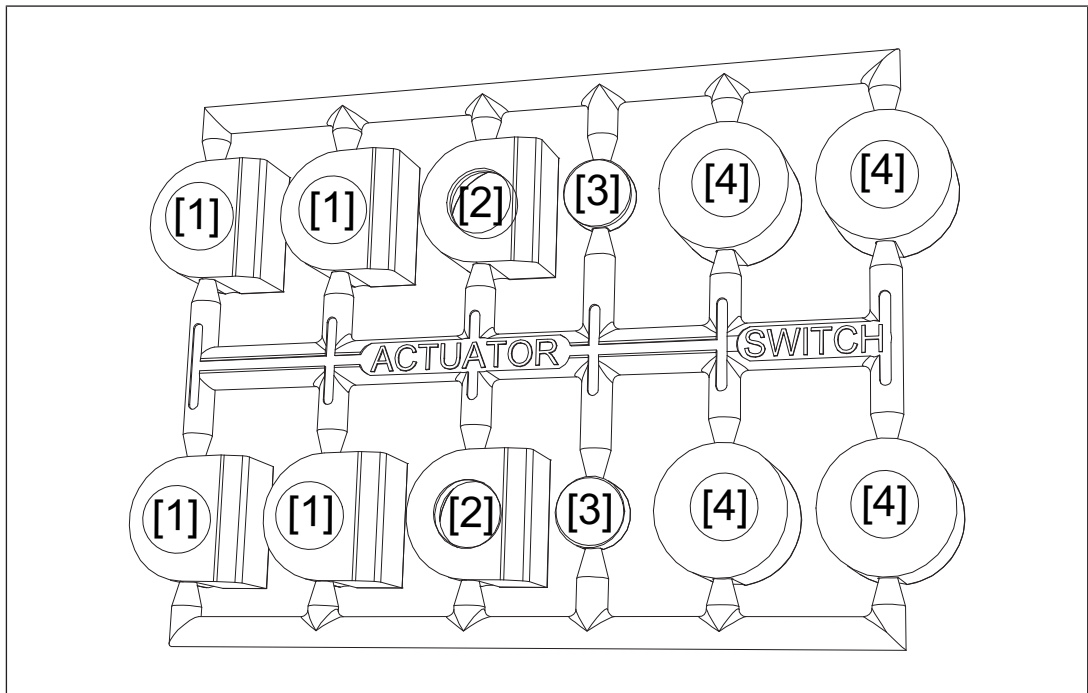

Fig.: Seals

- [1]: 4 seals for actuators
- [2]: Unused seals
- [3]: 2 seals for actuators
- [4]: 2 seals for switches, 2 seals unused

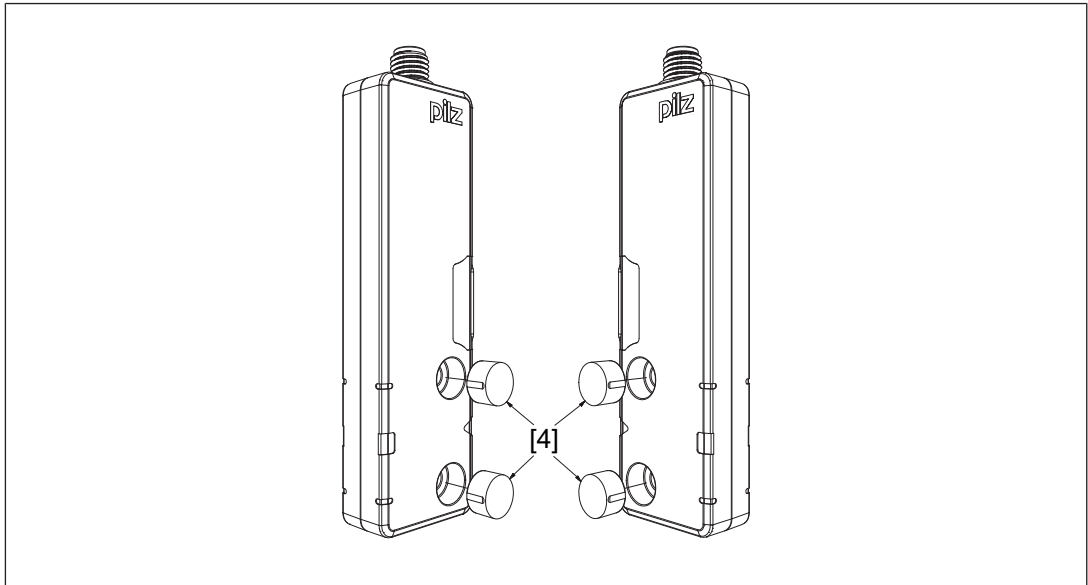

Fig.: Applying the screw cover [4] on the switch

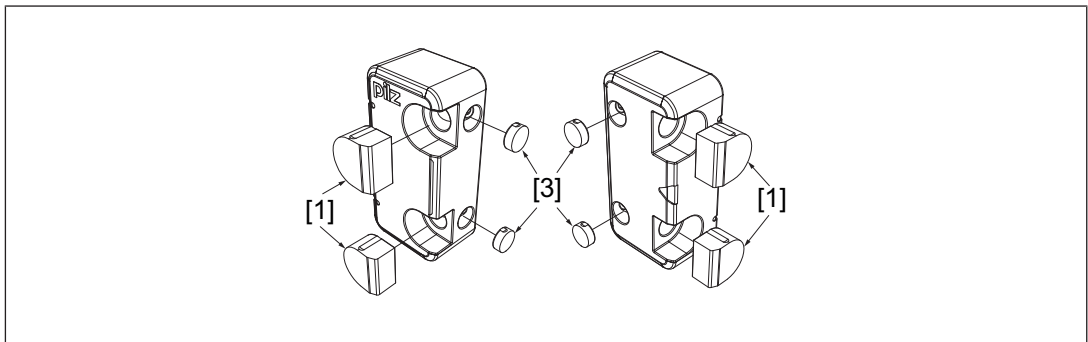

Fig.: Applying the screw covers [1] and [3] on the actuator



**CAUTION!**

Malfunction due to missing gate end stop on semicircle marking

If you use the semicircle marking on a safety gate, make sure that a gate end stop is used. The actuator may not be moved beyond the limit of the response range (see diagram).

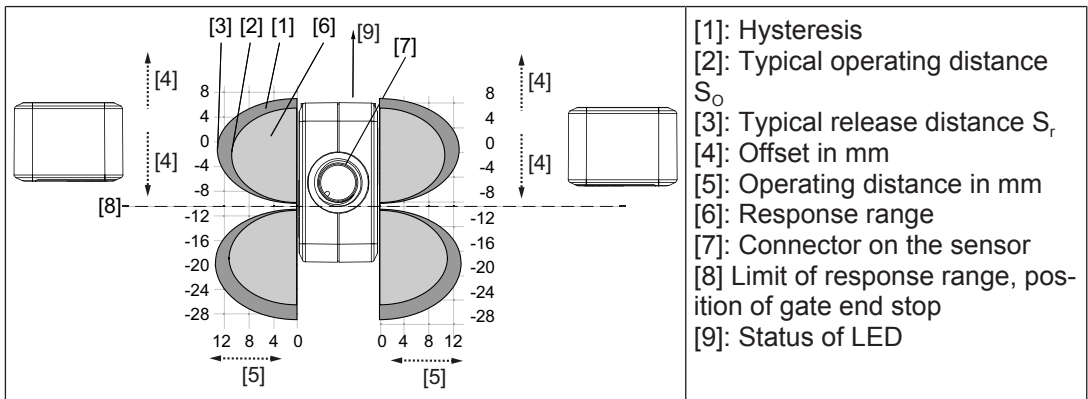



**Procedure:**

1. Drill holes (for M4 screws) in the mounting surface to secure the actuator and sensor (see [Dimensions in mm](#) [ 23]).
2. Use a screw to fix the sensor to the mounting surface.  
Make sure that the sensor marking that is be used for operation can be operated using the actuator from the right side.
3. Do not fully tighten the second screw on the safety switch.
4. Use a screw to fix the actuator to the mounting surface.  
Make sure that the actuator with the marking (triangle) points towards the marking on the sensor.
5. Do not fully tighten the second screw on the actuator.
6. Align the safety switch and tighten the screws.
7. Align the actuator and tighten the screws.

For simpler installation, the mounting brackets with order number 532 110 can be used.





**Adjustment**

- ▶ The stated operating distances (see [Technical details](#) [ 24]) only apply when the safety switch and actuator are installed facing each other in parallel. Operating distances may deviate if other arrangements are used.
- ▶ Note the maximum permitted lateral and vertical offset (see [Operating distances](#) [ 10] and [Lateral and vertical offset](#) [ 13]).





**Operation**

Check the function of the safety switch before commissioning.













**Status indicators:****Legend:**

	LED off
	LED on
	LED flashes (500 ms on, 500 ms off)
	LED flashes quickly (50 ms on, 950 ms off)

**Normal mode**

LED status		Switch status
Device	 Green	Ready for operation
Safety Gate	 yel- low	Actuator is within the response range
	 Off	Actuator is outside the response range
Input	 yel- low	Both safety inputs are high
	 Off	Both safety inputs are low

**Error display**

LED status			Switch status	Remedy / measure
Device	Safety gate	Input		
 red	 Off	 Off	Internal error on switch	Change the switch
 red	 yellow	 yellow	Supply voltage is outside the tolerance range	Ensure the voltage supply corresponds to the <a href="#">Technical details [24]</a> .
 yellow	Display not definitive	Display not definitive	Supply voltage is at the limit of the tolerance range	Ensure the voltage supply corresponds to the <a href="#">Technical details [24]</a> .
 red	Display of last status	Display of last status	Outputs in fault condition	Check the outputs and switch the voltage off and then on again.
 green	 yellow	Display not definitive	Wrong actuator	Use the actuator PSEN cs5.1.
 Off	 yellow	 yellow	Switch doesn't start	Change the switch.

### Dimensions in mm

Safety switch	
Actuator	

**Legend:**

- [1] Square marking
- [2] Triangle marking
- [3] LEDs
- [4] Semicircle marking

## Technical details

<b>General</b>	
Approvals	CE, EAC (Eurasian), ECOLAB, FCC, IC, TÜV, UL/cUL
Sensor's mode of operation	Transponder
Codification in accordance with ISO 14119	Low
Building class in accordance with ISO 14119	4
Classification to EN 60947-5-3	PDDB
<b>Electrical data</b>	
Supply voltage	
Voltage	24,0 V
Kind	DC
Voltage tolerance	-20 %/+20 %
Output of external power supply (DC)	1,0 W
Max. switching frequency	3 Hz
Max. cable capacitance at the safety outputs	
No-load, PNOZ with relay contacts	40 nF
PNOZmulti, PNOZelog, PSS	40 nF
Max. inrush current impulse	
Current pulse, A1	0,50 A
No-load current	25 mA
<b>Inputs</b>	
Number	2
Voltage at inputs	24 V DC
Input current range	1,6 - 3,0 mA
<b>Semiconductor outputs</b>	
OSSD safety outputs	2
Signal outputs	1
Switching current per output	100 mA
Breaking capacity per output	2,4 W
Residual current at outputs	400 µA
Voltage drop at OSSDs	1,0 V
Conditional rated short circuit current	100 A
Lowest operating current	0 mA
Utilisation category in accordance with EN 60947-1	DC-12
<b>Times</b>	
Test pulse duration, safety outputs	150 µs
Switch-on delay	
after UB is applied	1,0 s
Inputs typ.	1 ms
Inputs max.	3 ms
Actuator typ.	30 ms
Actuator max.	50 ms



<b>Times</b>	
Delay-on de-energisation	
Inputs typ.	2 ms
Inputs max.	4 ms
Actuator typ.	30 ms
Actuator max.	40 ms
Risk time in accordance with EN 60947-5-3	150 ms
Supply interruption before de-energisation in the input circuit	450,0 µs
Supply interruption before de-energisation	20 ms
Simultaneity, channel 1 and 2	∞
<b>Environmental data</b>	
Ambient temperature	
In accordance with the standard	EN 60068-2-14
Temperature range	-25 - 70 °C
Storage temperature	
In accordance with the standard	EN 60068-2-1/-2
Temperature range	-40 - 85 °C
Climatic suitability	
In accordance with the standard	EN 60068-2-30
Humidity	93 % r. h. at 40 °C
EMC	EN 60947-5-3
Vibration	
In accordance with the standard	EN 60947-5-2
Frequency	10,0 - 55,0 Hz
Amplitude	1,00 mm
Shock stress	
In accordance with the standard	EN 60947-5-2
Acceleration	30g
Duration	11 ms
Airgap creepage	
Overvoltage category	III
Pollution degree	3
Rated insulation voltage	75 V
Rated impulse withstand voltage	1,00 kV
Protection type	
Housing	IP66, IP67
<b>Mechanical data</b>	
Actuator 1	PSEN cs5.1
Operating distances	
Repetition accuracy switching distances	3 %
Change of operating distance with temperature changes	+0,02mm/°C

**Mechanical data**

Operating distances when the actuator approaches square marking

Assured operating distance Sao	<b>8 mm</b>
Assured release distance Sar	<b>20 mm</b>
Typical operating distance So	<b>11 mm</b>
Typical release distance Sr	<b>14 mm</b>
Typical hysteresis	<b>2 mm</b>

Operating distances when the actuator approaches triangle marking

Assured operating distance Sao	<b>4 mm</b>
Assured release distance Sar	<b>12 mm</b>
Typical operating distance So	<b>5 mm</b>
Typical release distance Sr	<b>8 mm</b>
Typical hysteresis	<b>2 mm</b>

Operating distances when the actuator approaches semicircle marking

Assured operating distance Sao	<b>6 mm</b>
Assured release distance Sar	<b>19 mm</b>
Typical operating distance So	<b>9 mm</b>
Typical release distance Sr	<b>11 mm</b>
Typical hysteresis	<b>2 mm</b>

Min. distance between safety switches **250 mm**

Sensor flush installation in accordance with EN 60947-5-2

**Yes, follow installation guidelines**

Connection type

**M8, 8-pin male connector**

Material

**Lexan 9945, PA+GF, PBT**

Fixing screws torque settings

**1,00 Nm**

Dimensions

Height	<b>26,4 mm</b>
Width	<b>97,6 mm</b>
Depth	<b>13,0 mm</b>

Actuator dimensions

Height	<b>18,0 mm</b>
Width	<b>37,0 mm</b>
Depth	<b>13,0 mm</b>

Weight of safety switch

**48 g**

Weight of actuator

**10 g**

Weight

**58 g**

Where standards are undated, the 2014-09 latest editions shall apply.

### Safety characteristic data

Operating mode	EN ISO 13849-1: 2008 PL	EN ISO 13849-1: 2008 Category	EN 62061 SIL CL	EN 62061 PFH <sub>D</sub> [1/h]	IEC 61511 SIL	IEC 61511 PFD	EN ISO 13849-1: 2008 T <sub>M</sub> [year]
2-ch. OSSD	PL e	Cat. 4	SIL CL 3	9,56E-10	–	8,51E-06	20

All the units used within a safety function must be considered when calculating the safety characteristic data.



#### INFORMATION

A safety function's SIL/PL values are **not** identical to the SIL/PL values of the units that are used and may be different. We recommend that you use the PAscal software tool to calculate the safety function's SIL/PL values.

### Supplementary data

#### Radio approval

*USA/Canada*

**FC** FCC ID: VT8- PSENC55  
IC: 7482A- PSENC55

FCC/IC-Requirements:  
This product complies with Part 15 of the FCC Rules and with Industry Canada licence-exempt RSS standards. Operation is subject to the following two conditions:  
1) this product may not cause harmful interference, and  
2) this product must accept any interference received, including interference that may cause undesired operation.

Changes or modifications made to this product not expressly approved by Pilz may void the FCC authorization to operate this equipment.

NOTE: This equipment has been tested and found to comply with the limits for a Class A digital device, pursuant to Part 15 of the FCC Rules. These limits are designed to provide reasonable protection against harmful interference when the equipment is operated in a commercial environment. This equipment generates, uses, and can radiate radio frequency energy and, if not installed and used in accordance with the instruction manual, may cause harmful interference to radio communications. Operation of this equipment in a residential area is likely to cause harmful interference in which case the user will be required to correct the interference at his own expense.

Le présent produit est conforme aux CNR d'Industrie Canada applicables aux appareils radio exempts de licence. L'exploitation est autorisée aux deux conditions suivantes:  
(1) le produit ne doit pas produire de brouillage, et  
(2) l'utilisateur de le produit doit accepter tout brouillage radioélectrique subi, même si le brouillage est susceptible d'en compromettre le fonctionnement.

### Order reference

#### System

Product type	Features	Connection type	Order no.
PSEN cs5.1p/PSEN cs5.1 1unit	Safety gate system, coded	8-pin M8 connector	542 000
PSEN cs5.1p 1switch	Safety switch, coded	8-pin M8 connector	542 050
PSEN cs5.1 1actuator	Actuator, coded		542 080

**Accessories**

Product type	Features	Order no.
PSEN Winkel / bracket	Mounting bracket	532 110

**EC declaration of conformity**

This product/these products meet the requirements of the directive 2006/42/EC for machinery of the European Parliament and of the Council. The complete EC Declaration of Conformity is available on the Internet at [www.pilz.com/downloads](http://www.pilz.com/downloads).

Representative: Norbert Fröhlich, Pilz GmbH & Co. KG, Felix-Wankel-Str. 2, 73760 Ostfildern, Germany

# Support

Technical support is available from Pilz round the clock.

## Americas

Brazil  
+55 11 97569-2804  
Canada  
+1 888-315-PILZ (315-7459)  
Mexico  
+52 55 5572 1300  
USA (toll-free)  
+1 877-PILZUSA (745-9872)

## Asia

China  
+86 21 60880878-216  
Japan  
+81 45 471-2281  
South Korea  
+82 31 450 0680

## Australia

+61 3 95446300

## Europe

Austria  
+43 1 7986263-0  
Belgium, Luxembourg  
+32 9 3217575  
France  
+33 3 88104000  
Germany  
+49 711 3409-444  
Ireland  
+353 21 4804983  
Italy  
+39 0362 1826711

## Scandinavia

+45 74436332

## Spain

+34 938497433

## Switzerland

+41 62 88979-30

## The Netherlands

+31 347 320477

## Turkey

+90 216 5775552

## United Kingdom

+44 1536 462203

You can reach our international hotline on:

+49 711 3409-444

support@pilz.com

Pilz develops environmentally-friendly products using ecological materials and energy-saving technologies. Offices and production facilities are ecologically designed, environmentally-aware and energy-saving. So Pilz offers sustainability, plus the security of using energy-efficient products and environmentally-friendly solutions.

### The 4-fold safety of automation

COMPONENTS  
SYSTEMS  
SERVICES

Technical Ecological  
Personal Economical

Energy  
saving by Pilz

BLUECOMPETENCE

Alliance Member

Partner of the Engineering Industry Sustainability Initiative



Pilz GmbH & Co. KG  
Felix-Wankel-Straße 2  
73760 Ostfildern, Germany  
Tel.: +49 711 3409-0  
Fax: +49 711 3409-133  
info@pilz.com  
www.pilz.com

**pilz**  
the spirit of safety

CMSE, InduraNET p, PAS4000, PAScal, PASconfig, Pilz, PIT, PLID, PMCPrimo, PMCProtego, PMCTendo, PMD, PMI, PNOZ, Primo, PSEN, PSS, PVS, Safety SafetyYE, SafetyNET p, the spirit of safety, are registered and protected trademarks of Pilz GmbH & Co. KG in some countries. We would point out that product features may vary from the details stated in this document, depending on the status at the time of publication and the scope of the equipment. We accept no responsibility for the validity, accuracy and entirety of the text and graphics presented in this information. Please contact our Technical Support if you have any questions.