

# FCC Radio Test Report

## FCC ID: VSFMS3A

This report concerns: Original Grant

**Project No.** : 1907H013  
**Equipment** : Tablet  
**Brand Name** : Juniper Systems  
**Test Model** : MS3A  
**Series Model** : N/A  
**Applicant** : Juniper Systems  
**Address** : 1132 W 1700 N Logan, UT 84321  
**Manufacturer** : Juniper Systems  
**Address** : 1132 W 1700 N Logan, UT 84321  
**Date of Receipt** : Jul. 16, 2019  
**Date of Test** : Jul. 18, 2019~Nov. 03, 2019  
**Issued Date** : Nov. 07, 2019  
**Report Version** : R00  
**Test Sample** : Engineering Sample No.: SH2019091645/SH2019091646/  
SH2019091641-5 /SH2019091641-6  
**Standard(s)** : FCC Part15, Subpart C (15.247)  
ANSI C63.10-2013  
KDB 558074 D01 15.247 Meas Guidance V05r02

The above equipment has been tested and found compliance with the requirement of the relative standards by BTL Inc.

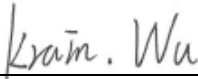
  
Prepared by : Krain Wu

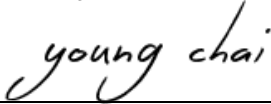
  
Approved by : Young Chai



Certificate # 5123.03

Add: No. 29, Jintang Road, Tangzhen Industry Park, Pudong New Area, Shanghai 201210, China

TEL: +86-021-61765666

Web: www.newbtl.com

**Declaration**

**BTL** represents to the client that testing is done in accordance with standard procedures as applicable and that test instruments used has been calibrated with standards traceable to international standard(s) and/or national standard(s).

**BTL's** reports apply only to the specific samples tested under conditions. It is manufacture's responsibility to ensure that additional production units of this model are manufactured with the identical electrical and mechanical components. **BTL** shall have no liability for any declarations, inferences or generalizations drawn by the client or others from **BTL** issued reports.

The report must not be used by the client to claim product certification, approval, or endorsement by NVLAP, NIST, A2LA, or any agency of the U.S. Government.

This report is the confidential property of the client. As a mutual protection to the clients, the public and ourselves, the test report shall not be reproduced, except in full, without our written approval.

**BTL's** laboratory quality assurance procedures are in compliance with the **ISO/IEC 17025** requirements, and accredited by the conformity assessment authorities listed in this test report.

**BTL** is not responsible for the sampling stage, so the results only apply to the sample as received.

The information, data and test plan are provided by manufacturer which may affect the validity of results, so it is manufacturer's responsibility to ensure that the apparatus meets the essential requirements of applied standards and in all the possible configurations as representative of its intended use.

**Limitation**

For the use of the authority's logo is limited unless the Test Standard(s)/Scope(s)/Item(s) mentioned in this test report is (are) included in the conformity assessment authorities acceptance respective.

Please note that the measurement uncertainty is provided for informational purpose only and are not use in determining the Pass/Fail results.

<b>Table of Contents</b>	<b>Page</b>
<b>REPORT ISSUED HISTORY</b>	<b>5</b>
<b>1 . SUMMARY OF TEST RESULTS</b>	<b>6</b>
1.1 TEST FACILITY	7
1.2 MEASUREMENT UNCERTAINTY	7
1.3 TEST ENVIRONMENT CONDITIONS	7
<b>2 . GENERAL INFORMATION</b>	<b>8</b>
2.1 GENERAL DESCRIPTION OF EUT	8
2.2 DESCRIPTION OF TEST MODES	10
2.3 PARAMETERS OF TEST SOFTWARE	11
2.4 BLOCK DIAGRAM SHOWING THE CONFIGURATION OF SYSTEM TESTED	11
2.5 SUPPORT UNITS	11
<b>3 . AC POWER LINE CONDUCTED EMISSIONS TEST</b>	<b>12</b>
3.1 LIMIT	12
3.2 TEST PROCEDURE	12
3.3 DEVIATION FROM TEST STANDARD	12
3.4 TEST SETUP	13
3.5 EUT OPERATING CONDITIONS	13
3.6 TEST RESULTS	13
<b>4 . RADIATED EMISSION TEST</b>	<b>14</b>
4.1 LIMIT	14
4.2 TEST PROCEDURE	15
4.3 DEVIATION FROM TEST STANDARD	15
4.4 TEST SETUP	16
4.5 EUT OPERATING CONDITIONS	17
4.6 TEST RESULT - 9 KHZ TO 30 MHZ	17
4.7 TEST RESULT - 30 MHZ TO 1000 MHZ	17
4.8 TEST RESULT - ABOVE 1000 MHZ	17
<b>5 . BANDWIDTH TEST</b>	<b>18</b>
5.1 LIMIT	18
5.2 TEST PROCEDURE	18
5.3 DEVIATION FROM STANDARD	18
5.4 TEST SETUP	18
5.5 EUT OPERATION CONDITIONS	18

<b>Table of Contents</b>	<b>Page</b>
<b>5.6 TEST RESULTS</b>	<b>18</b>
<b>6 . MAXIMUM OUTPUT POWER &amp; E.I.R.P. TEST</b>	<b>19</b>
6.1 LIMIT	19
6.2 TEST PROCEDURE	19
6.3 DEVIATION FROM STANDARD	19
6.4 TEST SETUP	19
6.5 EUT OPERATION CONDITIONS	19
6.6 TEST RESULTS	19
<b>7 . CONDUCTED SPURIOUS EMISSION</b>	<b>20</b>
7.1 LIMIT	20
7.2 TEST PROCEDURE	20
7.3 DEVIATION FROM STANDARD	20
7.4 TEST SETUP	20
7.5 EUT OPERATION CONDITIONS	20
7.6 TEST RESULTS	20
<b>8 . POWER SPECTRAL DENSITY TEST</b>	<b>21</b>
8.1 LIMIT	21
8.2 TEST PROCEDURE	21
8.3 DEVIATION FROM STANDARD	21
8.4 TEST SETUP	21
8.5 EUT OPERATION CONDITIONS	21
8.6 TEST RESULTS	21
<b>9 . MEASUREMENT INSTRUMENTS LIST</b>	<b>22</b>
<b>APPENDIX A - AC POWER LINE CONDUCTED EMISSIONS</b>	<b>24</b>
<b>APPENDIX B - RADIATED EMISSION - 9 KHZ TO 30 MHZ</b>	<b>27</b>
<b>APPENDIX C - RADIATED EMISSION - 30 MHZ TO 1000 MHZ</b>	<b>32</b>
<b>APPENDIX D - RADIATED EMISSION - ABOVE 1000 MHZ</b>	<b>35</b>
<b>APPENDIX E - BANDWIDTH</b>	<b>60</b>
<b>APPENDIX F - MAXIMUM OUTPUT POWER &amp; E.I.R.P.</b>	<b>63</b>
<b>APPENDIX G - CONDUCTED SPURIOUS EMISSION</b>	<b>65</b>
<b>APPENDIX H - POWER SPECTRAL DENSITY</b>	<b>68</b>

**REPORT ISSUED HISTORY**

Report Version	Description	Issued Date
R00	Original Issue.	Nov. 07, 2019

### 1. SUMMARY OF TEST RESULTS

Test procedures according to the technical standard(s):

FCC Part15, Subpart C (15.247)				
Standard(s) Section	Test Item	Test Result	Judgment	Remark
15.207	AC Power Line Conducted Emissions	APPENDIX A	N/A	-----
15.247(d) 15.205(a) 15.209(a)	Radiated Emissions	APPENDIX B APPENDIX C APPENDIX D	PASS	-----
15.247(a)(2)	Bandwidth	APPENDIX E	PASS	-----
15.247(b)(3)	Maximum Output Power & e.i.r.p.	APPENDIX F	PASS	-----
15.247(d)	Conducted Spurious Emission	APPENDIX G	PASS	-----
15.247(e)	Power Spectral Density	APPENDIX H	PASS	-----
15.203	Antenna Requirement	-----	PASS	-----

**NOTE:**

(1) "N/A" denotes test is not applicable to this device.

### 1.1 TEST FACILITY

The test facilities used to collect the test data in this report is at the location of No. 29, Jintang Road, Tangzhen Industry Park, Pudong New Area, Shanghai 201210, China  
 BTL's Test Firm Registration Number for FCC: 476765  
 BTL's Designation Number for FCC: CN1241

### 1.2 MEASUREMENT UNCERTAINTY

ISO/IEC 17025 requires that an estimate of the measurement uncertainties associated with the emissions test results be included in the report. The measurement uncertainties given below are based on a 95% confidence level (based on a coverage factor (k=2))  
 The BTL measurement uncertainty as below table:

#### A. AC power line conducted emissions test:

Test Site	Method	Measurement Frequency Range	U, (dB)
SH-C01	CISPR	150 kHz~30MHz	± 2.26

#### B. Radiated emissions test:

Test Site	Method	Measurement Frequency Range	Ant. H / V	U, (dB)
SH-CB01	CISPR	9 KHz~30 MHz	V	3.79
		9 KHz~30 MHz	H	3.57
		30MHz~200MHz	V	4.04
		30MHz~200MHz	H	3.76
		200MHz~1,000MHz	V	4.24
		200MHz~1,000MHz	H	3.84
		1GHz~18GHz	V	4.46
		1GHz~18GHz	H	4.40
		18 GHz~40 GHz	V	3.95
		18 GHz~40 GHz	H	3.95

Note: Unless specifically mentioned, the uncertainty of measurement has not been taken into account to declare the compliance or non-compliance to the specification.

### 1.3 TEST ENVIRONMENT CONDITIONS

Test Item	Temperature	Humidity	Test Voltage	Tested By
AC Power Line Conducted Emissions	24°C	61%	AC 120V	Summer Xu
Radiated Emissions-9K-30MHz	23°C	55%	AC 120V	Summer Xu
Radiated Emissions-30 MHz to 1GHz	23°C	55%	AC 120V	Summer Xu
Radiated Emissions-Above 1000 MHz	23°C	55%	AC 120V	Summer Xu
Bandwidth	24°C	61%	AC 120V	Summer Xu
Maximum Output Power & e.i.r.p.	24°C	61%	AC 120V	Summer Xu
Conducted Spurious Emission	24°C	61%	AC 120V	Summer Xu
Power Spectral Density	24°C	61%	AC 120V	Summer Xu

## 2. GENERAL INFORMATION

### 2.1 GENERAL DESCRIPTION OF EUT

Equipment	Tablet
Brand Name	Juniper Systems
Test Model	MS3A
Series Model	N/A
Model Difference(s)	N/A
Software Version	MS3A-userdebug 9.1.0.1-20190619 eng.mirror.20190619.093211 test-keys
Hardware Version	DVT1
Power Source	#1 DC voltage supplied from AC/DC adapter. Model: PSAA30R-120 #2 Supplied from Li-ion battery pack.
Power Rating	#1 I/P: 100~240V 0.8A 50~60Hz O/P: 12V --- 2.5A #2 7.2V, 6.0A, 43.2W
Operation Frequency	2402 MHz ~ 2480 MHz
Modulation Technology	GFSK
Bit Rate of Transmitter	1Mbps/2Mbps
Max. Output Power	1.53 dBm (0.0014 W)
Max. e.i.r.p.	2.73 dBm (0.0019 W)

Note:

1. For a more detailed features description, please refer to the manufacturer's specifications or the user's manual.



## 2. Channel List:

Channel	Frequency (MHz)	Channel	Frequency (MHz)
00	2402	20	2442
01	2404	21	2444
02	2406	22	2446
03	2408	23	2448
04	2410	24	2450
05	2412	25	2452
06	2414	26	2454
07	2416	27	2456
08	2418	28	2458
09	2420	29	2460
10	2422	30	2462
11	2424	31	2464
12	2426	32	2466
13	2428	33	2468
14	2430	34	2470
15	2432	35	2472
16	2434	36	2474
17	2436	37	2476
18	2438	38	2478
19	2440	39	2480

## 3. Table for Filed Antenna:

Ant.	Brand	Model Name	Antenna Type	Connector	Gain (dBi)
1	N/A	N/A	PIFA	N/A	1.2

## 2.2 DESCRIPTION OF TEST MODES

The test system was pre-tested based on the consideration of all possible combinations of EUT operation mode.

Pretest Mode	Description
Mode 1	TX Mode <b>NOTE (1)</b>
Mode 2	TX Mode Channel 00 _1Mbps
Mode 3	TX Mode Channel 00 _2Mbps

Following mode(s) as (were) found to be the worst case(s) and selected for the final test.

<b>AC power line conducted emissions test</b>	
Final Test Mode	Description
Mode 2	TX Mode Channel 00 _1Mbps
Mode 3	TX Mode Channel 00 _2Mbps

<b>Radiated emissions test - Below 1GHz</b>	
Final Test Mode	Description
Mode 2	TX Mode Channel 00 _1Mbps
Mode 3	TX Mode Channel 00 _2Mbps

<b>Radiated emissions test - Above 1GHz</b>	
Final Test Mode	Description
Mode 1	TX Mode <b>NOTE (1)</b>

<b>Conducted test</b>	
Final Test Mode	Description
Mode 1	TX Mode <b>NOTE (1)</b>

Note:

- (1) The measurements are performed at the high, middle, low available channels.
- (2) For radiated emission above 1 GHz test, 1GHz~26.5GHz have been pre-tested and in this report only recorded the worst case. The remaining spurious points are all below the limit value of 20dB.

**2.3 PARAMETERS OF TEST SOFTWARE**

During testing channel & power controlling software provided by the customer was used to control the operating channel as well as the output power level. The RF output power selection is for the setting of RF output power expected by the customer and is going to be fixed on the firmware of the final end product power parameters of BT LE

Test Software	QRCT		
Frequency (MHz)	2402	2440	2480
Parameters	N/A	N/A	N/A

**2.4 BLOCK DIAGRAM SHOWING THE CONFIGURATION OF SYSTEM TESTED**

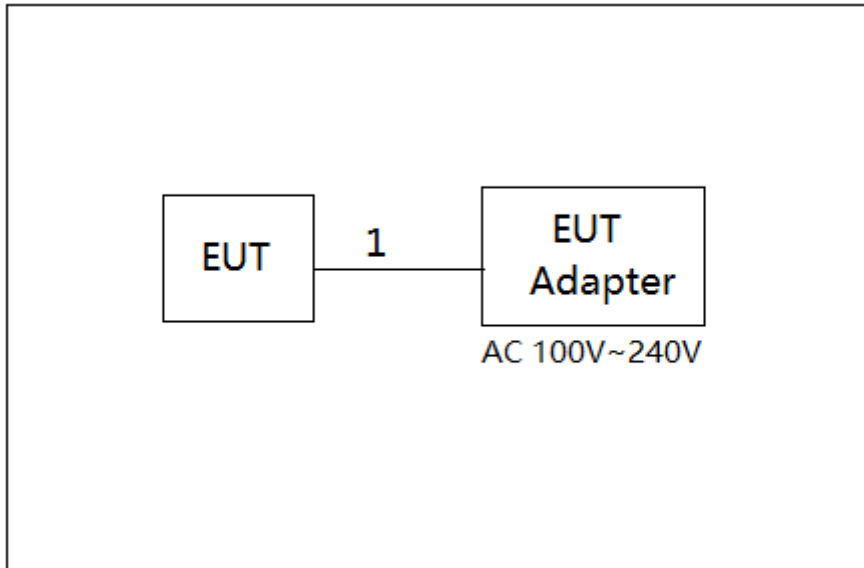

**2.5 SUPPORT UNITS**

Item	Equipment	Mfr/Brand	Model/Type No.	Series No.
-	-	-	-	-

Item	Cable Type	Shielded Type	Ferrite Core	Length
1	DC Cable	N/A	N/A	1.5m

### 3. AC POWER LINE CONDUCTED EMISSIONS TEST

#### 3.1 LIMIT

Frequency of Emission (MHz)	Limit (dB $\mu$ V)	
	Quasi-peak	Average
0.15 - 0.5	66 to 56*	56 to 46*
0.50 - 5.0	56	46
5.0 - 30.0	60	50

Note:

- (1) The tighter limit applies at the band edges.
- (2) The limit of " \* " marked band means the limitation decreases linearly with the logarithm of the frequency in the range.

The following table is the setting of the receiver

Receiver Parameters	Setting
Attenuation	10 dB
Start Frequency	0.15 MHz
Stop Frequency	30 MHz
IF Bandwidth	9 kHz

#### 3.2 TEST PROCEDURE

- a. The EUT was placed 0.8 meters from the horizontal ground plane with EUT being connected to the power mains through a line impedance stabilization network (LISN). All other support equipment powered from additional LISN(s). The LISN provide 50 Ohm/ 50uH of coupling impedance for the measuring instrument.
- b. Interconnecting cables that hang closer than 40 cm to the ground plane shall be folded back and forth in the center forming a bundle 30 to 40 cm long.
- c. I/O cables that are not connected to a peripheral shall be bundled in the center. The end of the cable may be terminated, if required, using the correct terminating impedance. The overall length shall not exceed 1 m.
- d. LISN at least 80 cm from nearest part of EUT chassis.
- e. For the actual test configuration, please refer to the related Item –EUT Test Photos.

#### 3.3 DEVIATION FROM TEST STANDARD

No deviation

### 3.4 TEST SETUP

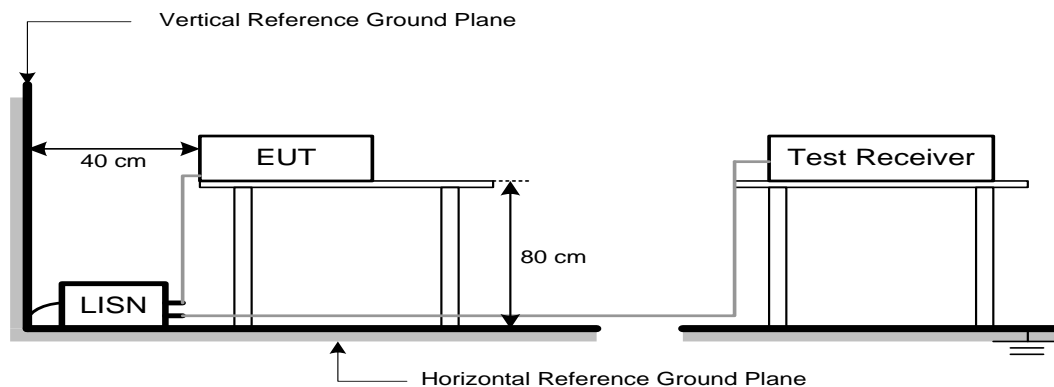

### 3.5 EUT OPERATING CONDITIONS

The EUT was configured for testing in a typical fashion (as a customer would normally use it). The EUT has been programmed to continuously transmit during test. This operating condition was tested and used to collect the included data.

### 3.6 TEST RESULTS

Please refer to the APPENDIX A.

Remark:

- (1) All readings are QP Mode value unless otherwise stated AVG in column of 'Note'. If the QP Mode Measured value compliance with the QP Limits and lower than AVG Limits, the EUT shall be deemed to meet both QP & AVG Limits and then only QP Mode was measured, but AVG Mode didn't perform. In this case, a "\*" marked in AVG Mode column of Interference Voltage Measured.
- (2) Measuring frequency range from 150 kHz to 30 MHz.

## 4. RADIATED EMISSION TEST

### 4.1 LIMIT

In case the emission fall within the restricted band specified on 15.205(a), then the 15.209(a) limit in the table below has to be followed.

#### LIMITS OF RADIATED EMISSION MEASUREMENT (9 kHz-1000 MHz)

Frequency (MHz)	Field Strength (microvolts/meter)	Measurement Distance (meters)
0.009-0.490	2400/F(kHz)	300
0.490-1.705	24000/F(kHz)	30
1.705-30.0	30	30
30-88	100	3
88-216	150	3
216-960	200	3
Above 960	500	3

#### LIMITS OF RADIATED EMISSION MEASUREMENT (9 kHz-30 MHz)

Frequency (MHz)	Magnetic field strength (H-Field) ( $\mu\text{A/m}$ )	Measurement Distance (meters)
0.009-0.490	6.37/F(kHz)	300
0.490-1.705	6.37/F(kHz)	30
1.705-30.0	0.08	30

#### LIMITS OF RADIATED EMISSION MEASUREMENT (30 MHz-1000 MHz)

Frequency (MHz)	Field Strength ( $\mu\text{V/m}$ at 3m)
30-88	100
88-216	150
216-960	200
Above 960	500

#### LIMITS OF RADIATED EMISSION MEASUREMENT (Above 1000 MHz)

Frequency (MHz)	(dBuV/m at 3 m)	
	Peak	Average
Above 1000	74	54

**Note:**

- (1) The limit for radiated test was performed according to FCC PART 15C.
- (2) The tighter limit applies at the band edges.
- (3) Emission level (dBuV/m)=20log Emission level (uV/m).
- (4) The test result calculated as following:  
 Measurement Value = Reading Level + Correct Factor  
 Correct Factor = Antenna Factor + Cable Loss - Amplifier Gain(if use)  
 Margin Level = Measurement Value - Limit Value

Spectrum Parameter	Setting
Attenuation	Auto
Start Frequency	1000 MHz
Stop Frequency	10th carrier harmonic
RBW / VBW (Emission in restricted band)	RBW 1 MHz VBW 3 MHz peak detector for Pk value RMS detector for AV value

Receiver Parameter	Setting
Attenuation	Auto
Start ~ Stop Frequency	9 kHz~90 kHz for PK/AVG detector
Start ~ Stop Frequency	90 kHz~110 kHz for QP detector
Start ~ Stop Frequency	110 kHz~490 kHz for PK/AVG detector
Start ~ Stop Frequency	490 kHz~30 MHz for QP detector
Start ~ Stop Frequency	30 MHz~1000 MHz for QP detector

#### 4.2 TEST PROCEDURE

- a. The measuring distance of 3 m shall be used for measurements. The EUT was placed on the top of a rotating table 0.8 meter above the ground at a 3 meter semi-anechoic chamber. The table was rotated 360 degrees to determine the position of the highest radiation.(below 1 GHz)
- b. The measuring distance of 3 m shall be used for measurements. The EUT was placed on the top of a rotating table 1.5 meter above the ground at a 3 meter semi-anechoic chamber. The table was rotated 360 degrees to determine the position of the highest radiation.(above 1 GHz)
- c. The height of the equipment or of the substitution antenna shall be 0.8m or 1.5m; the height of the test antenna shall vary between 1 m to 4 m. Both horizontal and vertical polarizations of the antenna are set to make the measurement.
- d. For each suspected emission, the EUT was arranged to its worst case and then the antenna was tuned to heights find the maximum reading (used Bore sight function).
- e. The receiver system was set to peak and average detect function and specified bandwidth with maximum hold mode when the test frequency is above 1 GHz.
- f. The initial step in collecting radiated emission data is a receiver peak detector mode pre-scanning the measurement frequency range. Significant peaks are then marked and then Quasi Peak detector mode re-measured.
- g. All readings are Peak unless otherwise stated QP in column of Note. Peak denotes that the Peak reading compliance with the QP Limits and then QP Mode measurement didn't perform. (below 1 GHz)
- h. All readings are Peak Mode value unless otherwise stated AVG in column of Note. If the Peak Mode Measured value compliance with the Peak Limits and lower than AVG Limits, the EUT shall be deemed to meet both Peak & AVG Limits and then only Peak Mode was measured, but AVG Mode didn't perform. (above 1 GHz)
- i. For the actual test configuration, please refer to the related Item –EUT Test Photos.

#### 4.3 DEVIATION FROM TEST STANDARD

No deviation

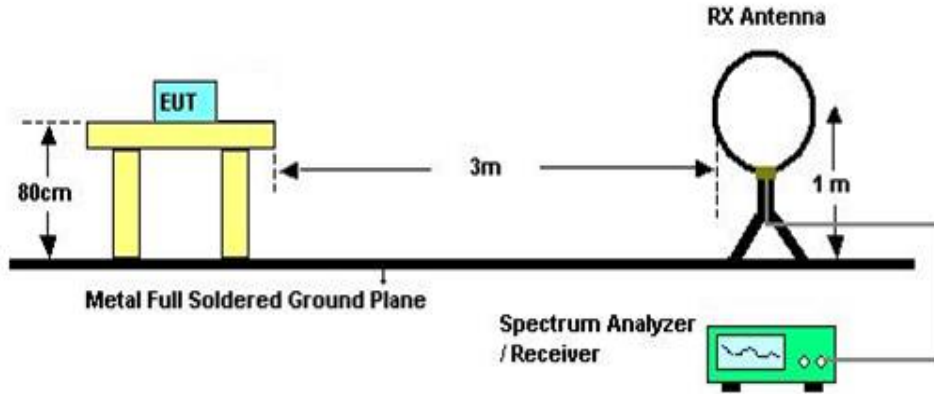
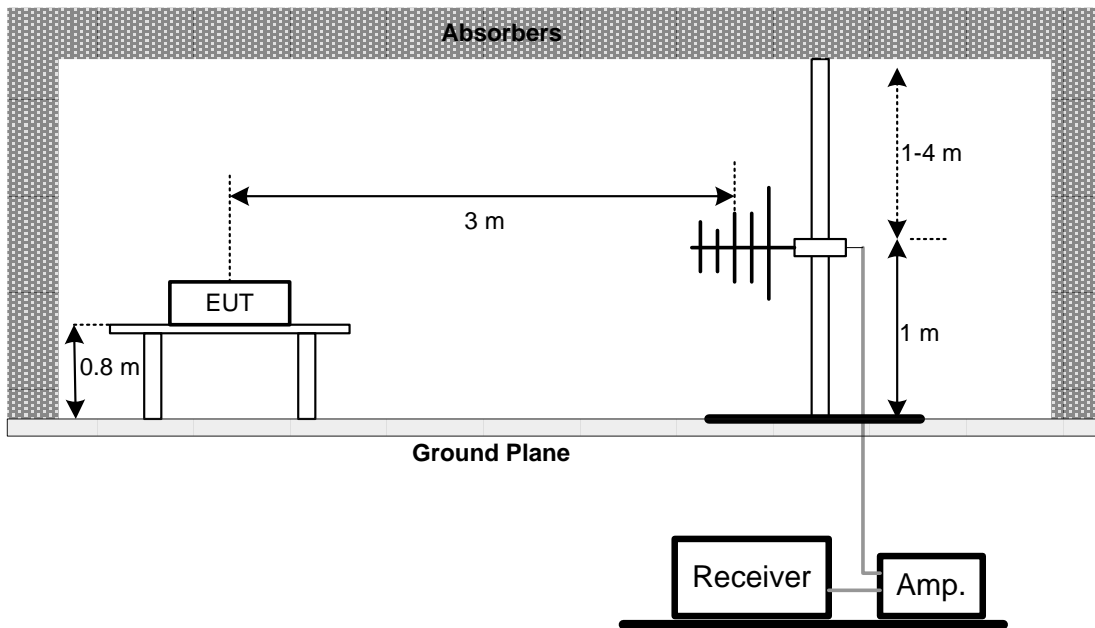
**4.4 TEST SETUP****9 kHz-30 MHz****30 MHz to 1 GHz**



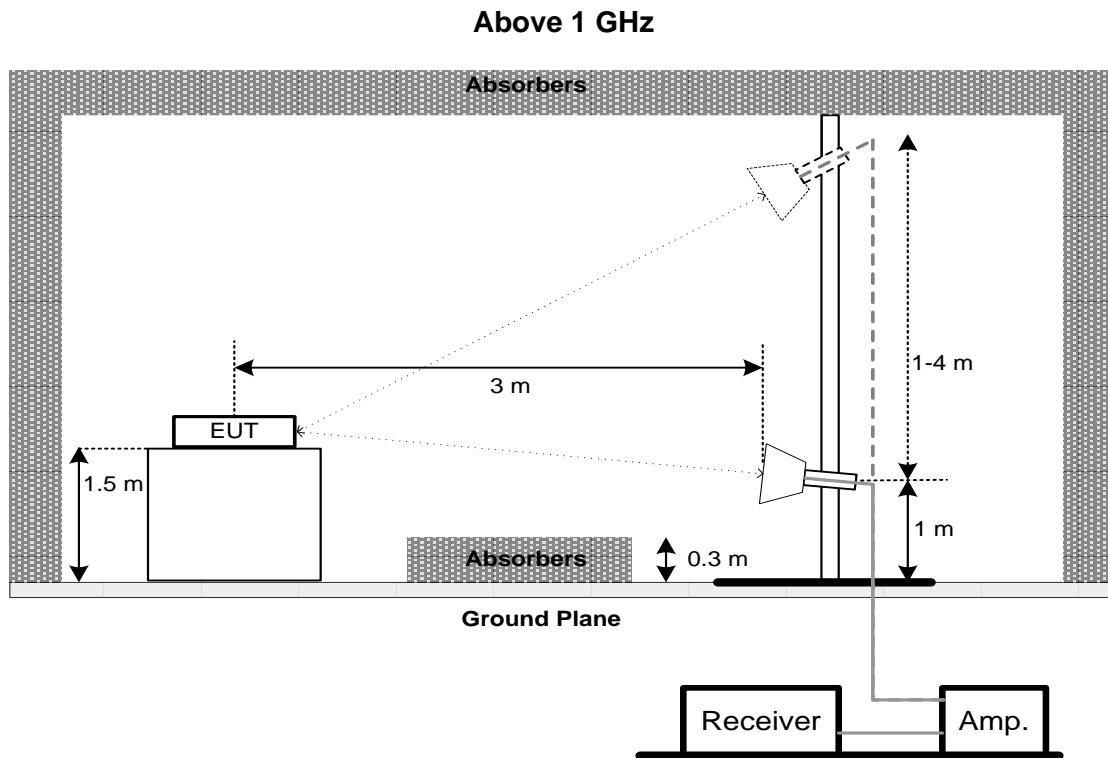

#### 4.5 EUT OPERATING CONDITIONS

The EUT was programmed to be in continuously transmitting mode.

#### 4.6 TEST RESULT - 9 kHz TO 30 MHz

Please refer to the APPENDIX B

Remark:

- (1) Distance extrapolation factor =  $40 \log (\text{specific distance} / \text{test distance})$  (dB).
- (2) Limit line = specific limits (dBuV) + distance extrapolation factor.

#### 4.7 TEST RESULT - 30 MHz TO 1000 MHz

Please refer to the APPENDIX C.

#### 4.8 TEST RESULT - ABOVE 1000 MHz

Please refer to the APPENDIX D.

Remark:

- (1) No limit: This is fundamental signal, the judgment is not applicable.  
For fundamental signal judgment was referred to Peak output test.

**5. BANDWIDTH TEST**

**5.1 LIMIT**

FCC Part15, Subpart C (15.247)		
Section	Test Item	Limit
15.247(a)(2)	Bandwidth	$\geq 500$ kHz (6 dB bandwidth)

**5.2 TEST PROCEDURE**

- a. The EUT was directly connected to the spectrum analyzer and antenna output port as show in the block diagram below.
- b. Spectrum Setting : RBW= 100 kHz, VBW=300 kHz, Sweep time = 2.5 ms.

**5.3 DEVIATION FROM STANDARD**

No deviation.

**5.4 TEST SETUP**



**5.5 EUT OPERATION CONDITIONS**

The EUT tested system was configured as the statements of 4.5 unless otherwise a special operating condition is specified in the follows during the testing.

**5.6 TEST RESULTS**

Please refer to the APPENDIX E.

## 6. MAXIMUM OUTPUT POWER & E.I.R.P. TEST

### 6.1 LIMIT

FCC Part15, Subpart C (15.247)		
Section	Test Item	Limit
15.247(b)(3)	Maximum Output Power	1 watt or 30 dBm

### 6.2 TEST PROCEDURE

- The EUT was directly connected to the spectrum analyzer and antenna output port as show in the block diagram below.
- The maximum conducted output power was performed in accordance with method 11.9.1.1 (for peak power) or 11.9.2.2 (for AVG power) of ANSI C63.10-2013.

### 6.3 DEVIATION FROM STANDARD

No deviation.

### 6.4 TEST SETUP



### 6.5 EUT OPERATION CONDITIONS

The EUT tested system was configured as the statements of 4.5 unless otherwise a special operating condition is specified in the follows during the testing.

### 6.6 TEST RESULTS

Please refer to the APPENDIX F.

## 7. CONDUCTED SPURIOUS EMISSION

### 7.1 LIMIT

For FCC

In any 100 kHz bandwidth outside the frequency band in which the spread spectrum or digitally modulated intentional radiator is operating, the radio frequency power that is produced by the intentional radiator shall be at least 20 dB below that in the 100 kHz bandwidth within the band that contains the highest level of the desired power, based on either an RF conducted or a radiated measurement, provided the transmitter demonstrates compliance with the peak Output Power limits. If the transmitter complies with the Output Power limits based on the use of RMS averaging over a time interval, as permitted under paragraph (b)(3) of this section, the attenuation required under this paragraph shall be 30 dB instead of 20 dB. Attenuation below the general limits specified in Section 15.209(a) is not required. In addition, radiated emissions which fall in the restricted bands, as defined in Section 15.205(a), must also comply with the radiated emission limits specified in Section 15.209(a) (see Section 15.205(c)).

### 7.2 TEST PROCEDURE

- a. The EUT was directly connected to the spectrum analyzer and antenna output port as show in the block diagram below.
- b. Spectrum Setting : RBW= 100 kHz, VBW=300 kHz, Sweep time = 10 ms.

### 7.3 DEVIATION FROM STANDARD

No deviation.

### 7.4 TEST SETUP



### 7.5 EUT OPERATION CONDITIONS

The EUT tested system was configured as the statements of 4.5 unless otherwise a special operating condition is specified in the follows during the testing.

### 7.6 TEST RESULTS

Please refer to the APPENDIX G.

## 8. POWER SPECTRAL DENSITY TEST

### 8.1 LIMIT

FCC Part15, Subpart C (15.247)		
Section	Test Item	Limit
15.247(e)	Power Spectral Density	8 dBm (in any 3 kHz)

### 8.2 TEST PROCEDURE

- The EUT was directly connected to the spectrum analyzer and antenna output port as show in the block diagram below.
- Spectrum Setting: RBW=3 kHz, VBW=10 kHz, Sweep time = auto.

### 8.3 DEVIATION FROM STANDARD

No deviation.

### 8.4 TEST SETUP



### 8.5 EUT OPERATION CONDITIONS

The EUT tested system was configured as the statements of 4.5 unless otherwise a special operating condition is specified in the follows during the testing.

### 8.6 TEST RESULTS

Please refer to the APPENDIX H.

## 9. MEASUREMENT INSTRUMENTS LIST

AC Power Line Conducted Emissions					
Item	Kind of Equipment	Manufacturer	Type No.	Serial No.	Calibrated until
1	Line Impedance Stabilisation Network	Schwarzbeck	NNLK 8121	8121-822	Mar. 29, 2020
2	TWO-LINE V-NETWORK	R&S	ENV216	101340	Nov. 20, 2019
3	Test Cable	emci	EMCRG400-BM-NM-10000	170628	Apr. 17, 2020
4	EMI Test Receiver	R&S	ESCI	100082	Mar. 29, 2020
5	50Ω Terminator	SHX	TF2-1G-A	17051602	Mar. 29, 2020
6	50Ω coaxial switch	Anritsu	MP59B	6201750902	Mar. 29, 2020
7	Measurement Software	Farad	EZ-EMC Ver.NB-03A1-01	N/A	N/A

Radiated Emissions - 9 kHz to 30MHz					
Item	Kind of Equipment	Manufacturer	Type No.	Serial No.	Calibrated until
1	Loop Antenna	EMCI	EMCI LPA600	275	Mar. 29, 2020
2	EMI Test Receiver	R&S	ESCI	100082	Mar. 29, 2020
3	Measurement Software	Farad	EZ-EMC Ver.NB-03A1-01	N/A	N/A

Radiated Emissions - 30 MHz to 1 GHz					
Item	Kind of Equipment	Manufacturer	Type No.	Serial No.	Calibrated until
1	TRILOG Broadband Antenna	Schwarzbeck	VULB 9168	719	Mar. 29, 2020
2	Pre-Amplifier	emci	EMC9135	980400	Mar. 29, 2020
3	MXE EMI Receiver	Keysight	N9038A	MY57150106	Mar. 29, 2020
4	Test Cable	emci	EMC104-SM-SM-7000	170330	Apr. 17, 2020
5	Test Cable	emci	EMC104-SM-SM-1000	170331	Apr. 17, 2020
6	Test Cable	emci	EMC104-SM-NM-3500	170621	Apr. 17, 2020
7	Measurement Software	Farad	EZ-EMC Ver.NB-03A1-01	N/A	N/A

Radiated Emissions - Above 1GHz					
Item	Kind of Equipment	Manufacturer	Type No.	Serial No.	Calibrated until
1	Double-Ridged Waveguide Horn Antenna	ETS-Lindgren	9120D	00206960	Mar. 29, 2020
2	Pre-Amplifier	emci	EMC012645SE	980421	Mar. 29, 2020
3	EXA Spectrum Analyzer	Keysight	N9010A	MY56480545	Mar. 29, 2020
4	Test Cable	emci	EMC104-SM-SM-7000	170330	Apr. 17, 2020
5	Test Cable	emci	EMC104-SM-SM-1000	170331	Apr. 17, 2020
6	Test Cable	emci	EMC104-SM-NM-3500	170621	Apr. 17, 2020
7	Measurement Software	Farad	EZ-EMC Ver.NB-03A1-01	N/A	N/A
8	MXE EMI Receiver	Keysight	N9038A	MY57150106	Mar. 29, 2020

Bandwidth					
Item	Kind of Equipment	Manufacturer	Type No.	Serial No.	Calibrated until
1	Spectrum Analyzer	R&S	FSP40	100626	Mar. 29, 2020

Maximum Output Power					
Item	Kind of Equipment	Manufacturer	Type No.	Serial No.	Calibrated until
1	Power Meter	Keysight	8990B	MY51000507	Mar. 29, 2020
2	Pulse Power Sensor	Keysight	N1923A	MY58310003	Mar. 29, 2020

Antenna Conducted Spurious Emissions					
Item	Kind of Equipment	Manufacturer	Type No.	Serial No.	Calibrated until
1	Spectrum Analyzer	R&S	FSP40	100626	Mar. 29, 2020

Power Spectral Density					
Item	Kind of Equipment	Manufacturer	Type No.	Serial No.	Calibrated until
1	Spectrum Analyzer	R&S	FSP40	100626	Mar. 29, 2020

Remark: "N/A" denotes no model name, serial no. or calibration specified.

All calibration period of equipment list is one year.

## **APPENDIX A - AC POWER LINE CONDUCTED EMISSIONS**



Test Mode: TX Mode

### Line

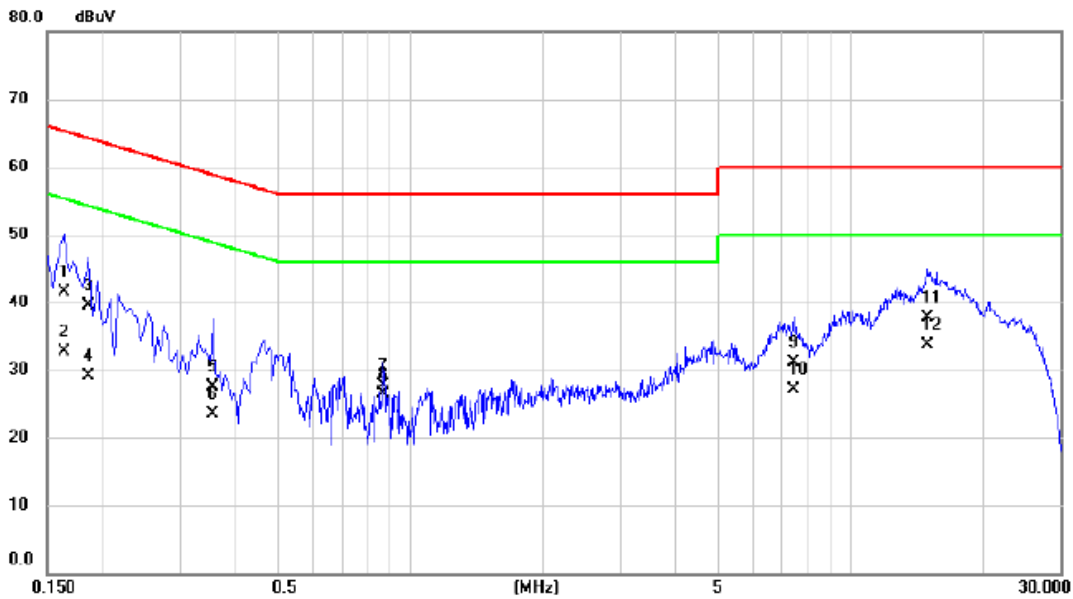

No.	Mk.	Freq. MHz	Reading Level dBuV	Correct Factor dB	Measure- ment dBuV	Limit dBuV	Margin dB	Detector	Comment
1		0.1635	31.80	9.78	41.58	65.28	-23.70	QP	
2		0.1635	22.90	9.78	32.68	55.28	-22.60	AVG	
3		0.1860	29.60	9.81	39.41	64.21	-24.80	QP	
4		0.1860	19.20	9.81	29.01	54.21	-25.20	AVG	
5		0.3570	17.60	9.87	27.47	58.80	-31.33	QP	
6		0.3570	13.70	9.87	23.57	48.80	-25.23	AVG	
7		0.8700	17.80	9.82	27.62	56.00	-28.38	QP	
8		0.8700	16.60	9.82	26.42	46.00	-19.58	AVG	
9		7.4355	20.90	10.14	31.04	60.00	-28.96	QP	
10		7.4355	16.90	10.14	27.04	50.00	-22.96	AVG	
11		14.9820	27.60	10.07	37.67	60.00	-22.33	QP	
12	*	14.9820	23.70	10.07	33.77	50.00	-16.23	AVG	

**REMARKS:**

(1) Measurement Value = Reading Level + Correct Factor.

(2) Margin Level = Measurement Value - Limit Value.

Test Mode: TX Mode

### Neutral

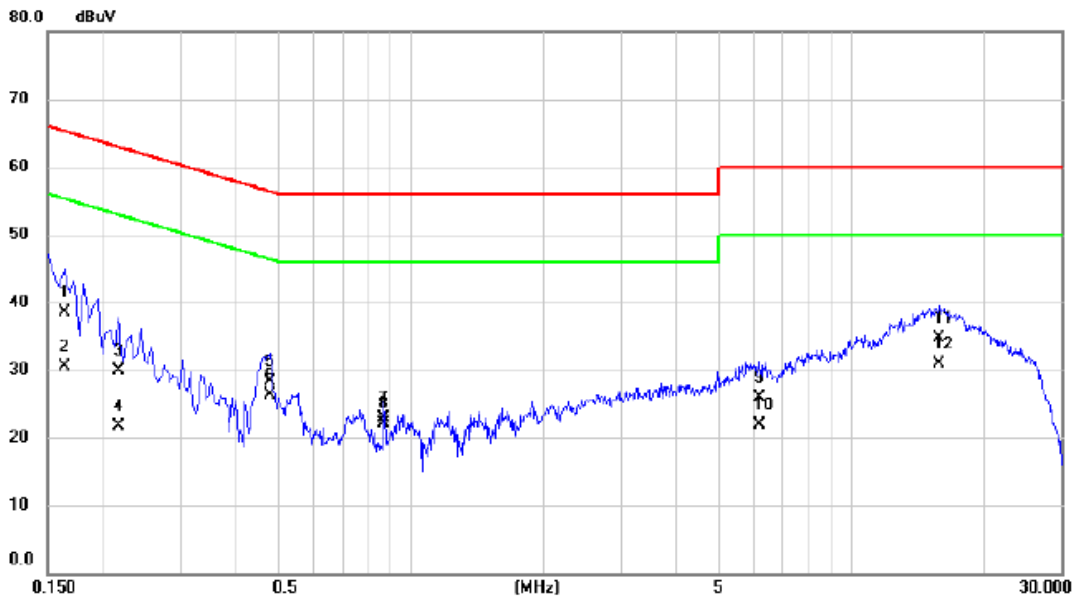

No.	Mk.	Freq.	Reading Level	Correct Factor	Measurement	Limit	Margin	Detector	Comment
		MHz	dBuV	dB	dBuV	dBuV	dB		
1		0.1635	29.00	9.59	38.59	65.28	-26.69	QP	
2		0.1635	21.00	9.59	30.59	55.28	-24.69	AVG	
3		0.2175	20.20	9.68	29.88	62.91	-33.03	QP	
4		0.2175	12.00	9.68	21.68	52.91	-31.23	AVG	
5		0.4785	18.50	9.81	28.31	56.37	-28.06	QP	
6		0.4785	16.40	9.81	26.21	46.37	-20.16	AVG	
7		0.8700	13.20	9.75	22.95	56.00	-33.05	QP	
8		0.8700	12.30	9.75	22.05	46.00	-23.95	AVG	
9		6.1845	15.90	10.10	26.00	60.00	-34.00	QP	
10		6.1845	11.90	10.10	22.00	50.00	-28.00	AVG	
11		15.8145	24.50	10.11	34.61	60.00	-25.39	QP	
12	*	15.8145	20.70	10.11	30.81	50.00	-19.19	AVG	

**REMARKS:**

- (1) Measurement Value = Reading Level + Correct Factor.
- (2) Margin Level = Measurement Value - Limit Value.

**APPENDIX B - RADIATED EMISSION - 9 KHZ TO 30 MHZ**

Test Mode: TX Mode

### Ant 0°

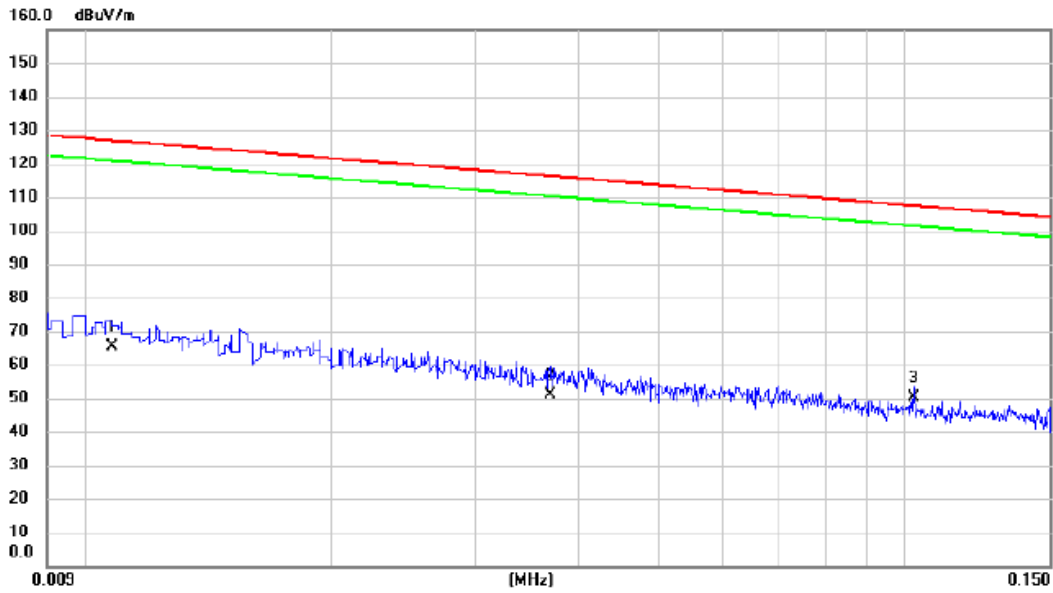

No.	Mk.	Freq. MHz	Reading Level dBuV	Correct Factor dB	Measure- ment dBuV/m	Limit dBuV/m	Margin dB	Detector	Comment
1		0.0108	-12.70	77.91	65.21	126.94	-61.73	AVG	
2		0.0370	-16.67	67.60	50.93	116.24	-65.31	AVG	
3	*	0.1025	-7.56	57.85	50.29	107.39	-57.10	QP	

**REMARKS:**

- (1) Measurement Value = Reading Level + Correct Factor.
- (2) Margin Level = Measurement Value - Limit Value.

Test Mode: TX Mode

Ant 0°

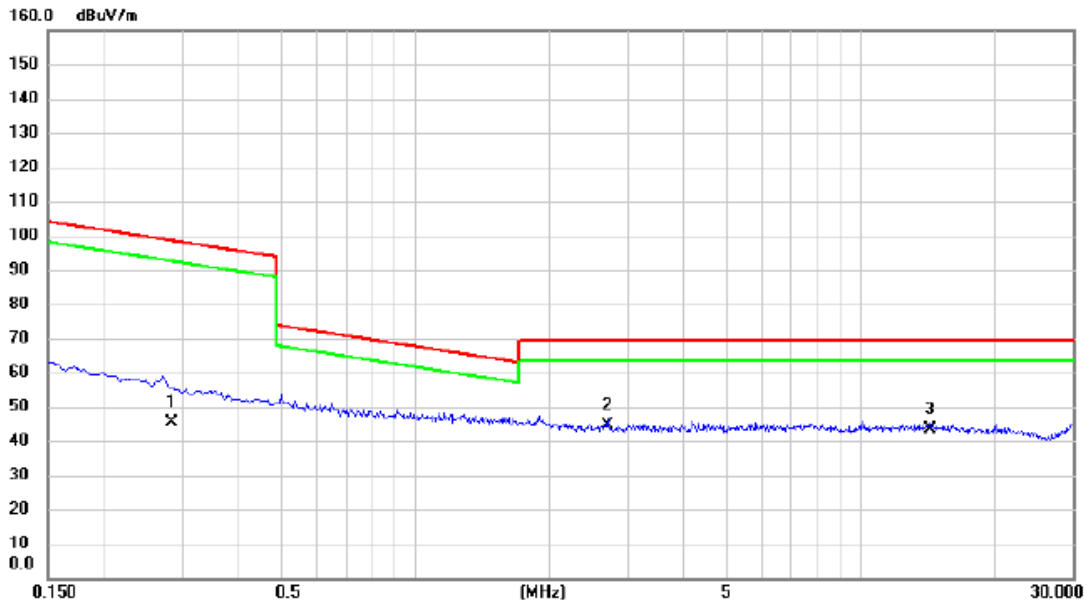

No.	Mk.	Freq. MHz	Reading Level dBuV	Correct Factor dB	Measure- ment dBuV/m	Limit dBuV/m	Margin dB	Detector	Comment
1		0.2850	-3.90	49.21	45.31	98.51	-53.20	AVG	
2	*	2.7015	6.23	38.24	44.47	69.54	-25.07	QP	
3		14.2980	5.35	38.14	43.49	69.54	-26.05	QP	

REMARKS:

(1) Measurement Value = Reading Level + Correct Factor.

(2) Margin Level = Measurement Value - Limit Value.

Test Mode: TX Mode

**Ant 90°**

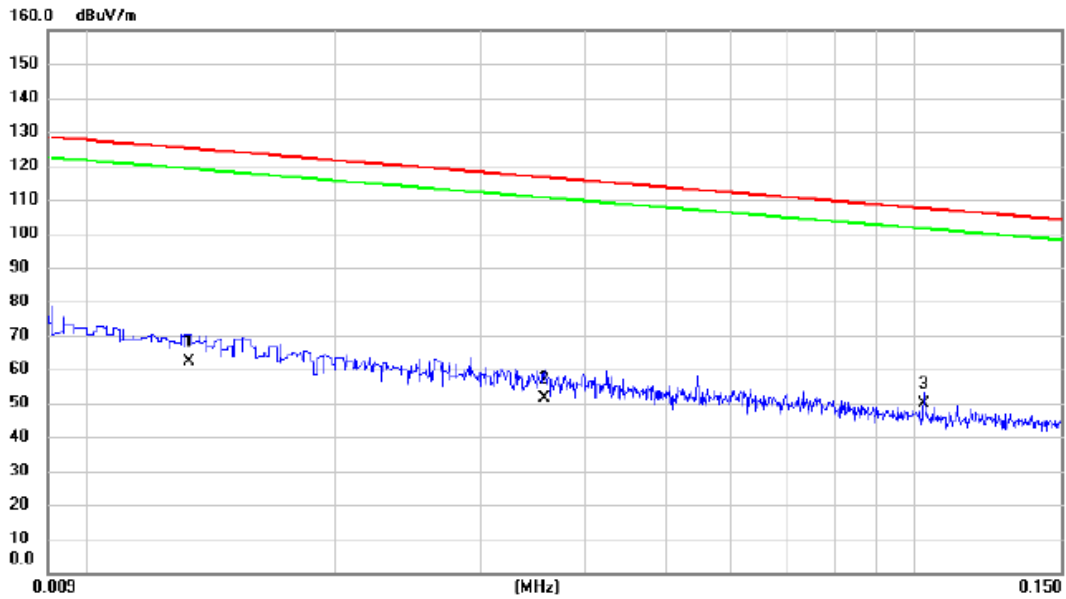

No.	Mk.	Freq. MHz	Reading Level dBuV	Correct Factor dB	Measure- ment dBuV/m	Limit dBuV/m	Margin dB	Detector	Comment
1		0.0133	-14.30	76.39	62.09	125.13	-63.04	AVG	
2		0.0357	-16.40	67.99	51.59	116.55	-64.96	AVG	
3	*	0.1025	-7.90	57.85	49.95	107.39	-57.44	QP	

**REMARKS:**

(1) Measurement Value = Reading Level + Correct Factor.

(2) Margin Level = Measurement Value - Limit Value.

Test Mode: TX Mode

**Ant 90°**

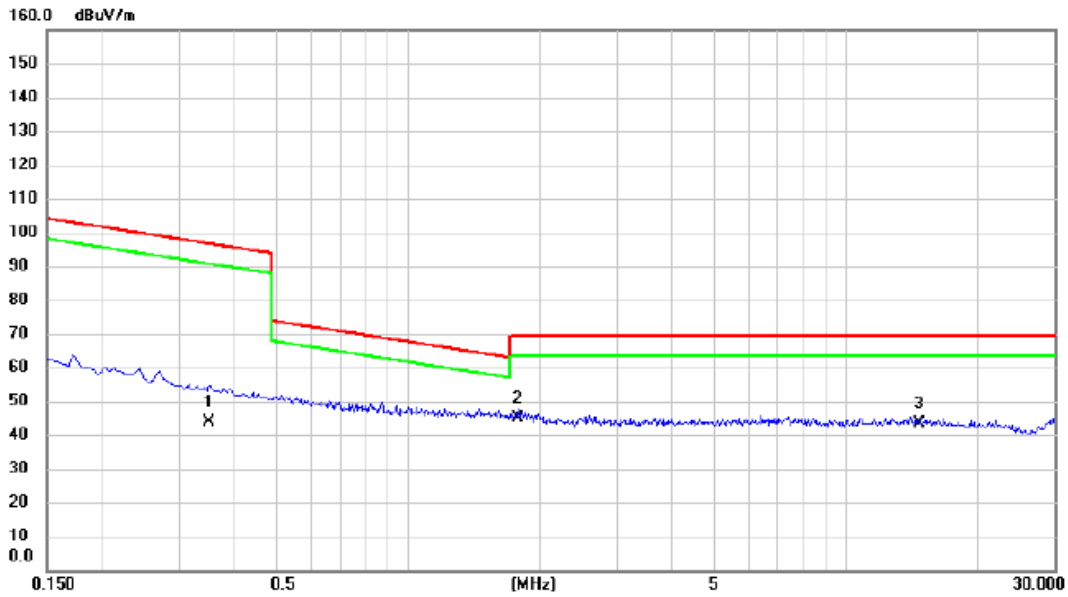

No. Mk.	Freq. MHz	Reading Level dBuV	Correct Factor dB	Measurement dBuV/m	Limit dBuV/m	Margin dB	Detector	Comment
1	0.3525	-3.80	47.55	43.75	96.66	-52.91	AVG	
2 *	1.7790	5.54	39.33	44.87	69.54	-24.67	QP	
3	14.7930	5.42	38.06	43.48	69.54	-26.06	QP	

**REMARKS:**

- (1) Measurement Value = Reading Level + Correct Factor.
- (2) Margin Level = Measurement Value - Limit Value.

**APPENDIX C - RADIATED EMISSION - 30 MHZ TO 1000 MHZ**



Test Mode: TX Mode

### Vertical

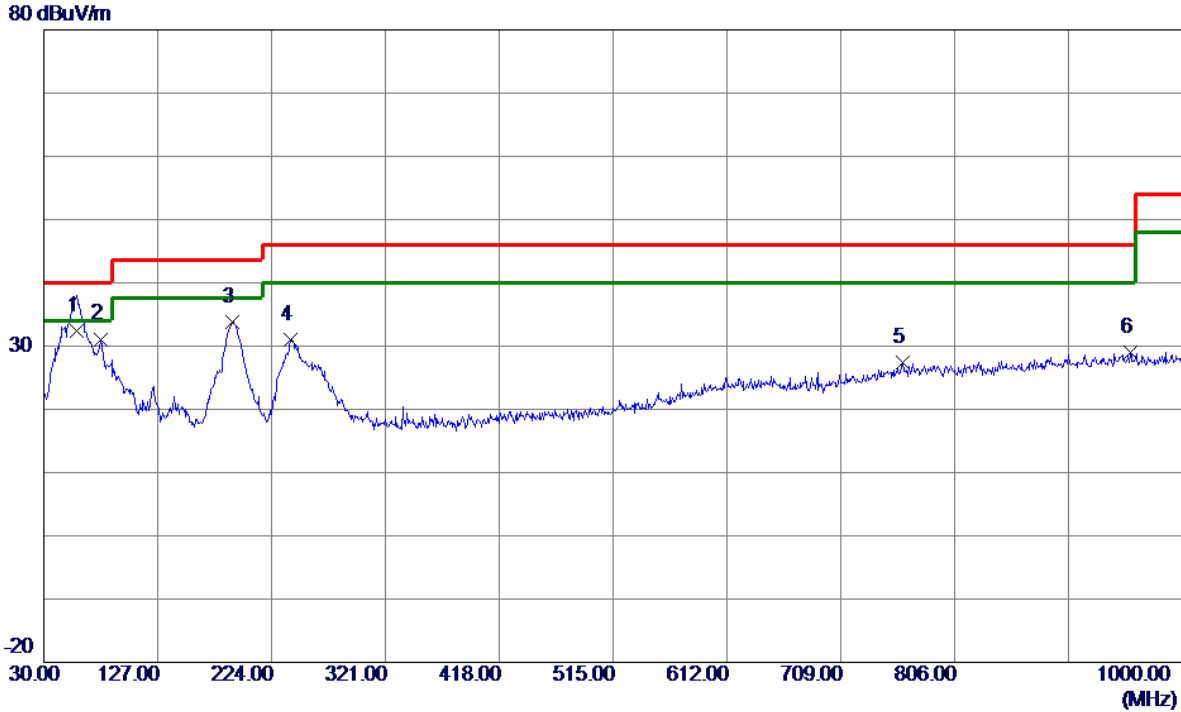

No.	Freq. MHz	Reading Level dBuV/m	Correct Factor dB	Measure ment dBuV/m	Limit dBuV/m	Margin dB	Detector	Comment
1 *	57.6450	49.85	-17.45	32.40	40.00	-7.60	QP	
2	78.5000	51.40	-20.30	31.10	40.00	-8.90	Peak	
3	190.5350	52.15	-18.27	33.88	43.50	-9.62	Peak	
4	240.4900	47.92	-16.91	31.01	46.00	-14.99	Peak	
5	761.3800	33.97	-6.62	27.35	46.00	-18.65	Peak	
6	955.8650	34.06	-5.11	28.95	46.00	-17.05	Peak	

**REMARKS:**

- (1) Measurement Value = Reading Level + Correct Factor.
- (2) Margin Level = Measurement Value - Limit Value.

Test Mode: TX Mode

### Horizontal

80 dBuV/m

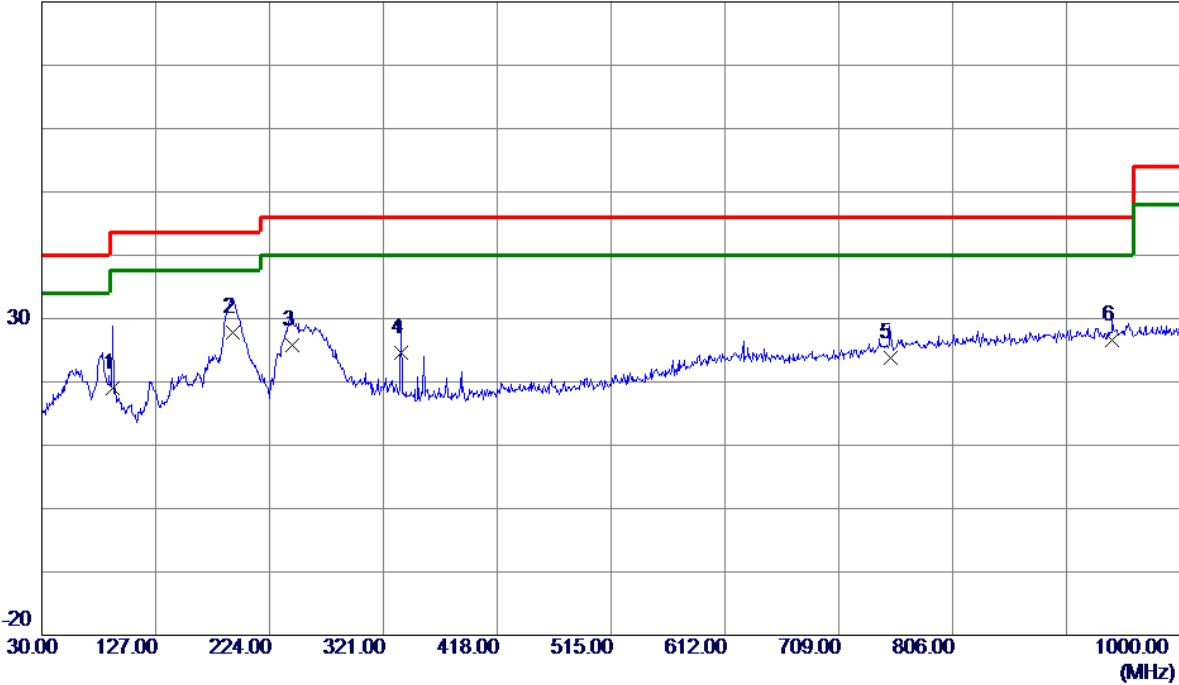

No.	Freq. MHz	Reading Level dBuV/m	Correct Factor dB	Measure ment dBuV/m	Limit dBuV/m	Margin dB	Detector	Comment
1	90.1400	39.47	-20.47	19.00	43.50	-24.50	Peak	
2 *	192.9600	46.15	-18.44	27.71	43.50	-15.79	Peak	
3	242.9150	42.73	-16.90	25.83	46.00	-20.17	Peak	
4	336.0350	38.41	-13.82	24.59	46.00	-21.41	Peak	
5	752.6500	30.46	-6.65	23.81	46.00	-22.19	Peak	
6	941.8000	31.82	-5.19	26.63	46.00	-19.37	Peak	

**REMARKS:**

- (1) Measurement Value = Reading Level + Correct Factor.
- (2) Margin Level = Measurement Value - Limit Value.

**APPENDIX D - RADIATED EMISSION - ABOVE 1000 MHZ**

Test Mode : TX 2402 MHz \_CH00\_1Mbps

### Vertical

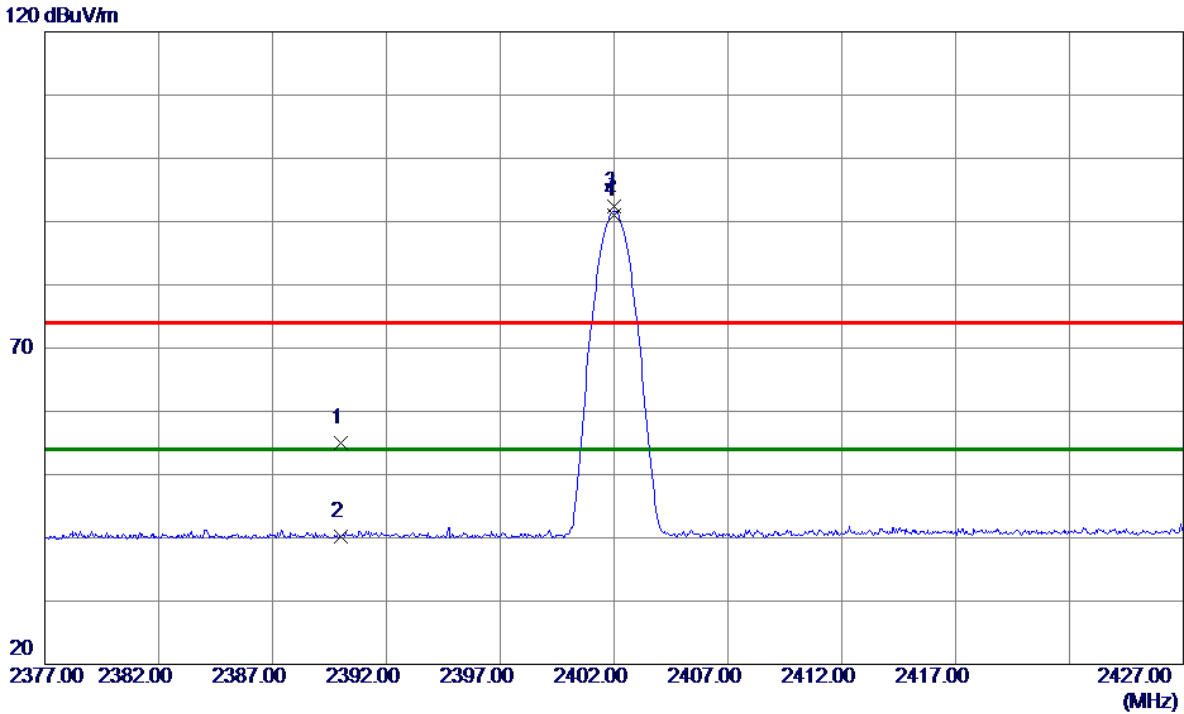

No.	Freq. MHz	Reading Level dBuV/m	Correct Factor dB	Measure ment dBuV/m	Limit dBuV/m	Margin dB	Detector	Comment
1	2390.0000	22.63	32.39	55.02	74.00	-18.98	Peak	
2	2390.0000	7.90	32.39	40.29	54.00	-13.71	AVG	
3	2402.0000	59.90	32.43	92.33	74.00	18.33	Peak	NO limit
4 *	2402.0000	58.56	32.43	90.99	54.00	36.99	AVG	NO limit

**REMARKS:**

(1) Measurement Value = Reading Level + Correct Factor.

(2) Margin Level = Measurement Value - Limit Value.

Test Mode : TX 2402 MHz \_CH00\_1Mbps

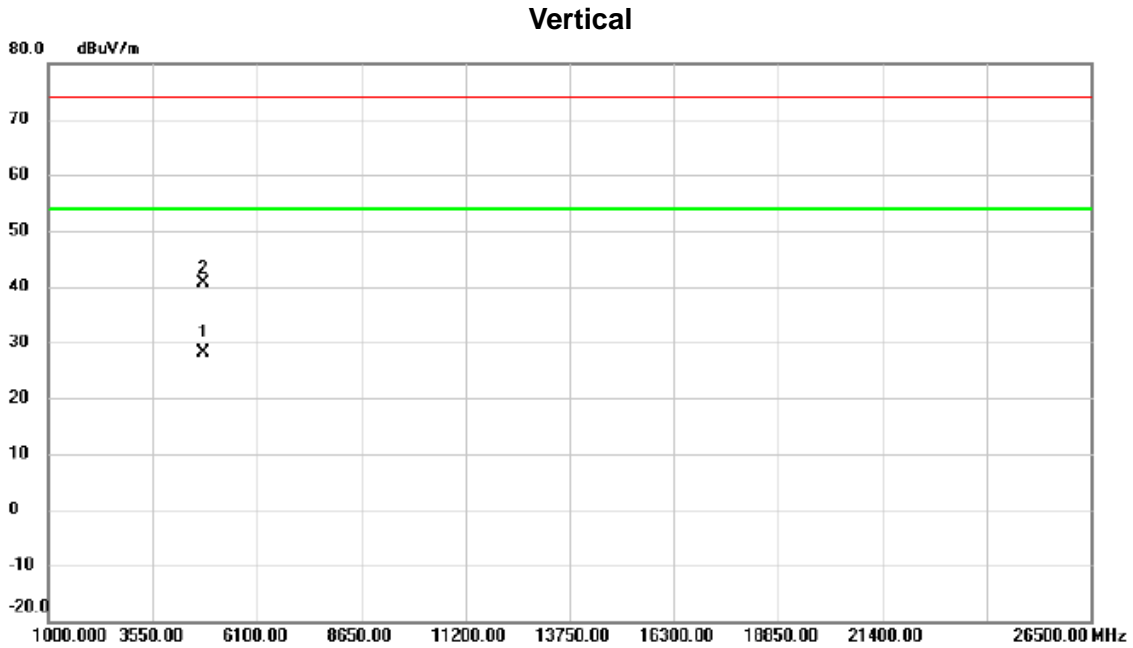

No.	Mk.	Freq. MHz	Reading Level dBuV	Correct Factor dB	Measure- ment dBuV/m	Limit dBuV/m	Margin dB	Detector	Comment
1	*	4804.000	37.94	-9.77	28.17	54.00	-25.83	AVG	
2		4805.505	50.45	-9.77	40.68	74.00	-33.32	peak	

**REMARKS:**

- (1) Measurement Value = Reading Level + Correct Factor.
- (2) Margin Level = Measurement Value - Limit Value.

Test Mode : TX 2402 MHz \_CH00\_1Mbps

### Horizontal

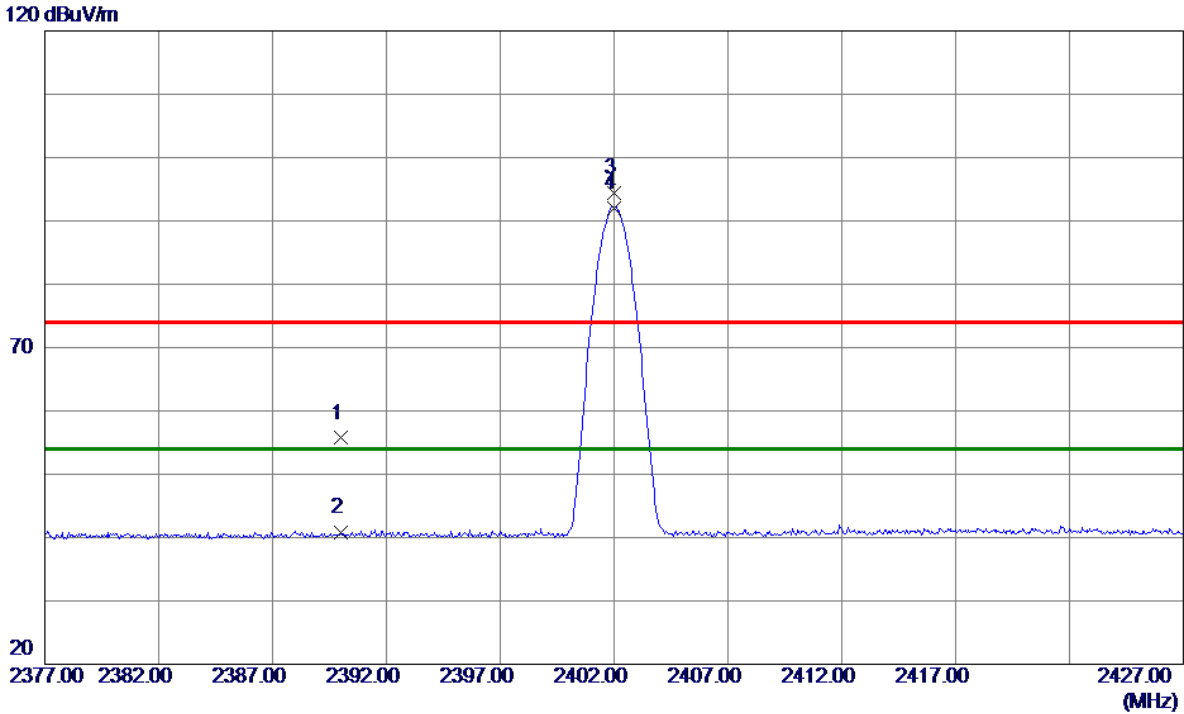

No.	Freq. MHz	Reading Level dBuV/m	Correct Factor dB	Measure ment dBuV/m	Limit dBuV/m	Margin dB	Detector	Comment
1	2390.0000	23.31	32.39	55.70	74.00	-18.30	Peak	
2	2390.0000	8.38	32.39	40.77	54.00	-13.23	AVG	
3	2402.0000	61.89	32.43	94.32	74.00	20.32	Peak	NO limit
4 *	2402.0000	59.57	32.43	92.00	54.00	38.00	AVG	NO limit

**REMARKS:**

- (1) Measurement Value = Reading Level + Correct Factor.
- (2) Margin Level = Measurement Value - Limit Value.

Test Mode : TX 2402 MHz \_CH00\_1Mbps

### Horizontal

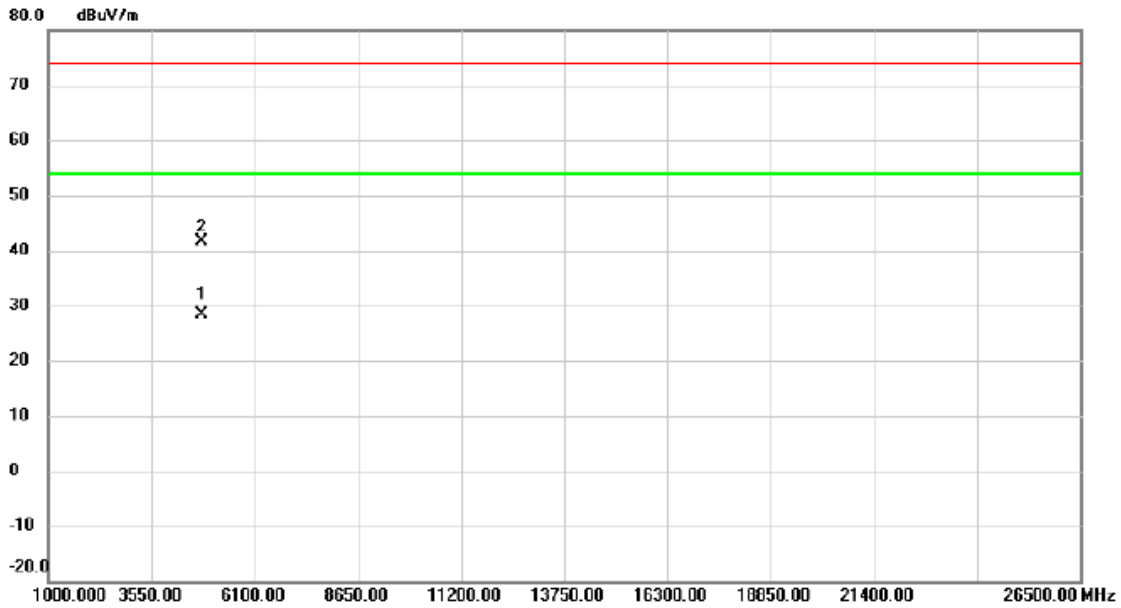

No.	Mk.	Freq. MHz	Reading Level dBuV	Correct Factor dB	Measure- ment dBuV/m	Limit dBuV/m	Margin dB	Detector	Comment
1	*	4804.000	38.14	-9.77	28.37	54.00	-25.63	AVG	
2		4806.440	51.32	-9.75	41.57	74.00	-32.43	peak	

**REMARKS:**

- (1) Measurement Value = Reading Level + Correct Factor.
- (2) Margin Level = Measurement Value - Limit Value.

Test Mode : TX 2440 MHz \_CH19\_1Mbps

### Vertical

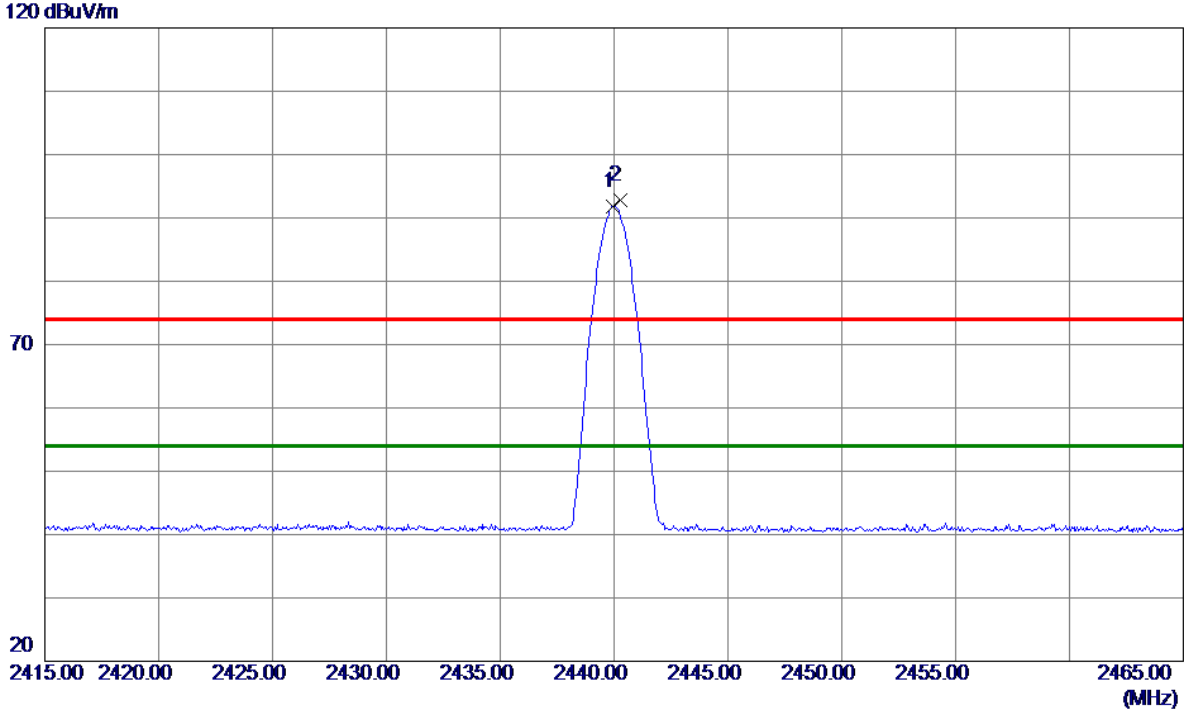

No.	Freq. MHz	Reading Level dBuV/m	Correct Factor dB	Measure ment dBuV/m	Limit dBuV/m	Margin dB	Detector	Comment
1 *	2439.9500	59.29	32.54	91.83	54.00	37.83	AVG	NO limit
2	2440.2500	60.30	32.54	92.84	74.00	18.84	Peak	NO limit

**REMARKS:**

- (1) Measurement Value = Reading Level + Correct Factor.
- (2) Margin Level = Measurement Value - Limit Value.



Test Mode : TX 2440 MHz \_CH19\_1Mbps

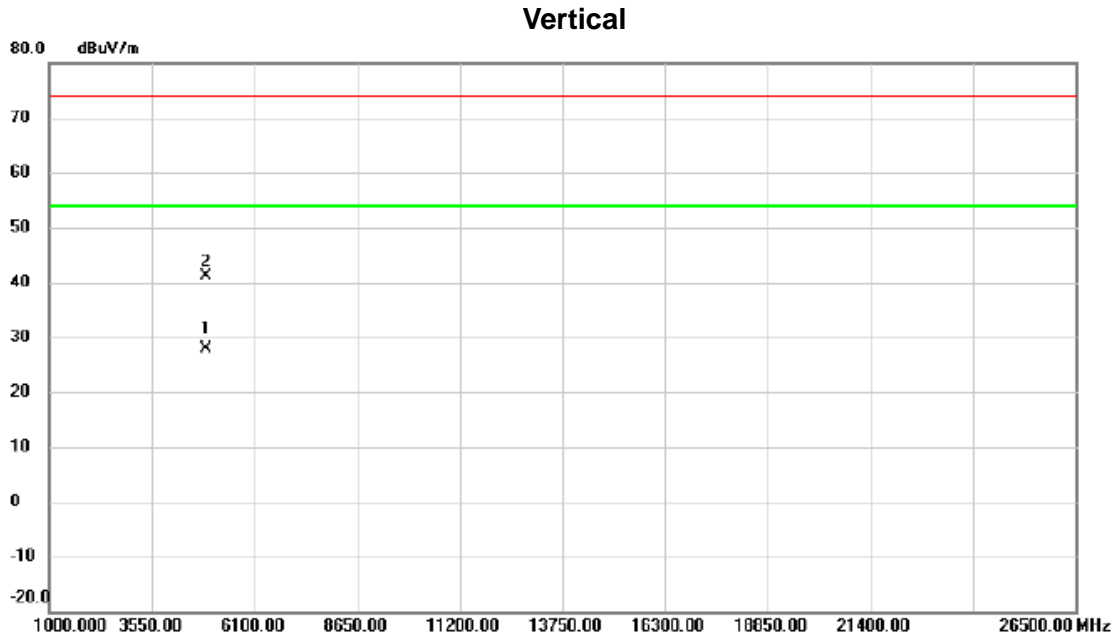

No.	Mk.	Freq. MHz	Reading Level dBuV	Correct Factor dB	Measure- ment dBuV/m	Limit dBuV/m	Margin dB	Detector	Comment
1	*	4882.000	37.37	-9.47	27.90	54.00	-26.10	AVG	
2		4882.345	50.64	-9.47	41.17	74.00	-32.83	peak	

**REMARKS:**

- (1) Measurement Value = Reading Level + Correct Factor.
- (2) Margin Level = Measurement Value - Limit Value.

Test Mode : TX 2440 MHz \_CH19\_1Mbps

### Horizontal

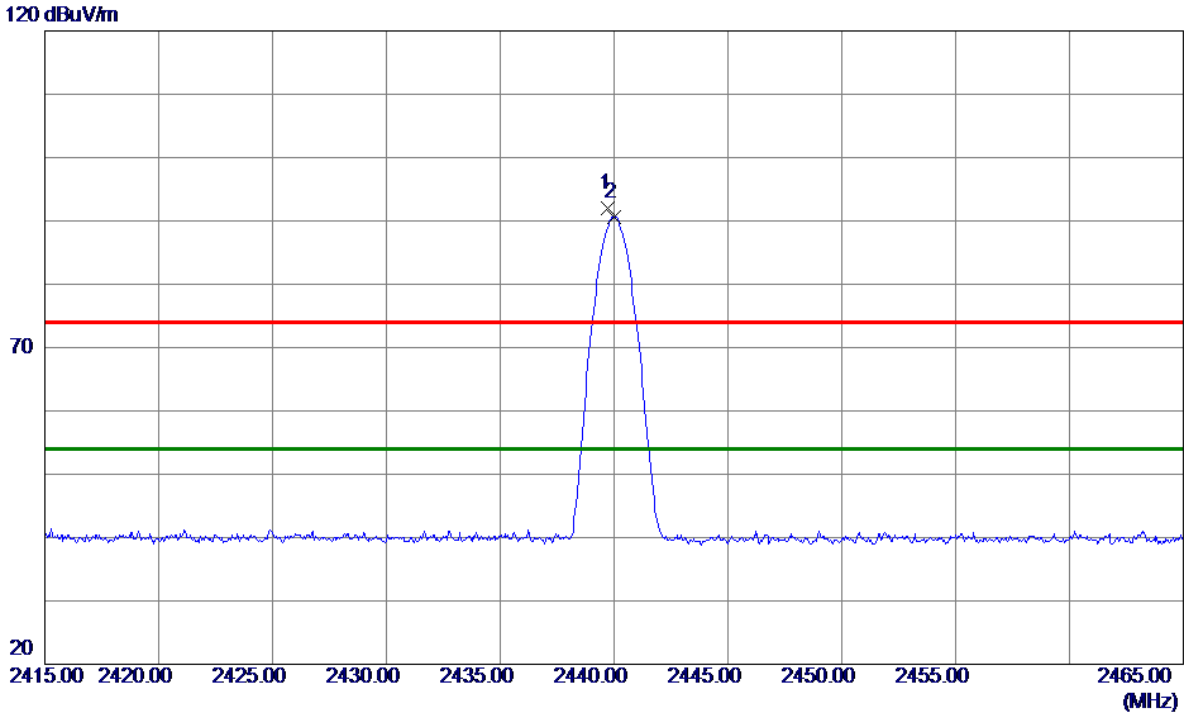

No.	Freq. MHz	Reading Level dBuV/m	Correct Factor dB	Measure ment dBuV/m	Limit dBuV/m	Margin dB	Detector	Comment
1	2439.7500	59.56	32.54	92.10	74.00	18.10	Peak	NO limit
2 *	2440.0000	58.15	32.54	90.69	54.00	36.69	AVG	NO limit

**REMARKS:**

- (1) Measurement Value = Reading Level + Correct Factor.
- (2) Margin Level = Measurement Value - Limit Value.

Test Mode : TX 2440 MHz \_CH19\_1Mbps

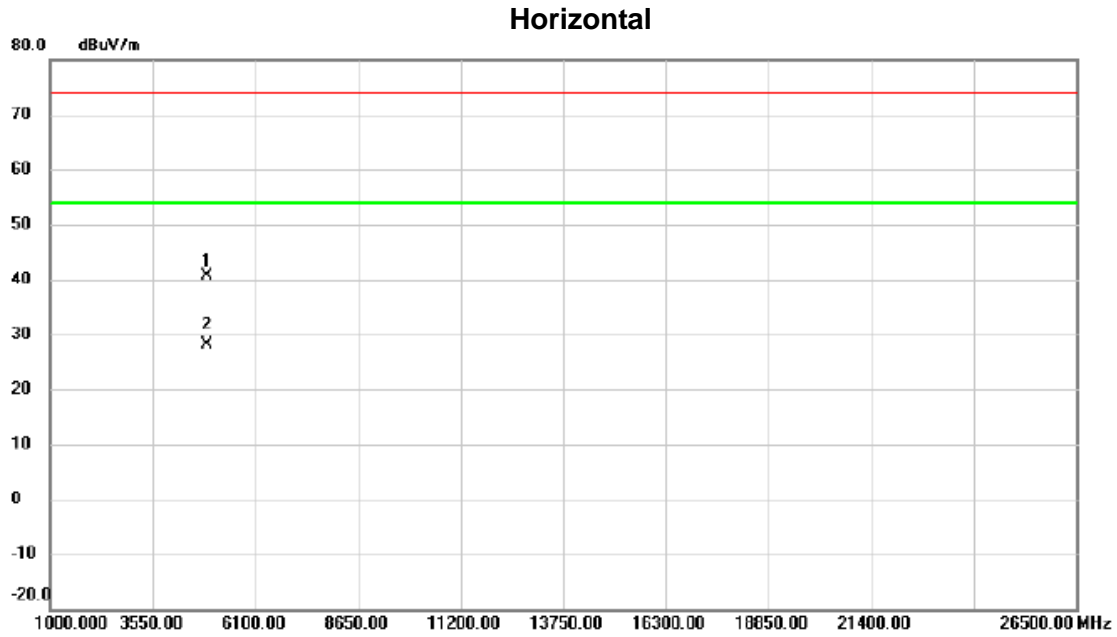

No. Mk.	Freq. MHz	Reading Level dBuV	Correct Factor dB	Measure- ment dBuV/m	Limit dBuV/m	Margin dB	Detector	Comment
1	4881.530	50.20	-9.47	40.73	74.00	-33.27	peak	
2 *	4882.000	37.52	-9.47	28.05	54.00	-25.95	AVG	

**REMARKS:**

- (1) Measurement Value = Reading Level + Correct Factor.
- (2) Margin Level = Measurement Value - Limit Value.

Test Mode : TX 2480 MHz \_CH39\_1Mbps

### Vertical

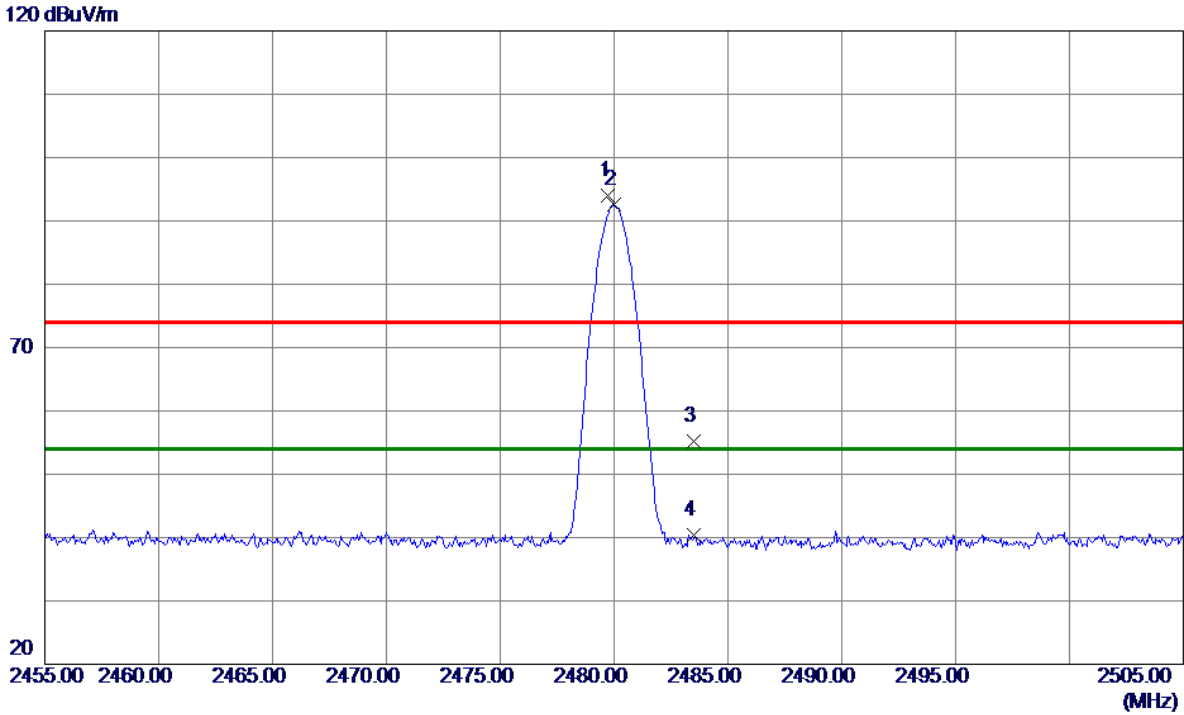

No.	Freq. MHz	Reading Level dBuV/m	Correct Factor dB	Measure ment dBuV/m	Limit dBuV/m	Margin dB	Detector	Comment
1	2479.7500	61.29	32.65	93.94	74.00	19.94	Peak	NO limit
2 *	2480.0000	59.92	32.65	92.57	54.00	38.57	AVG	NO limit
3	2483.5000	22.58	32.66	55.24	74.00	-18.76	Peak	
4	2483.5000	7.76	32.66	40.42	54.00	-13.58	AVG	

**REMARKS:**

- (1) Measurement Value = Reading Level + Correct Factor.
- (2) Margin Level = Measurement Value - Limit Value.

Test Mode : TX 2480 MHz \_CH39\_1Mbps

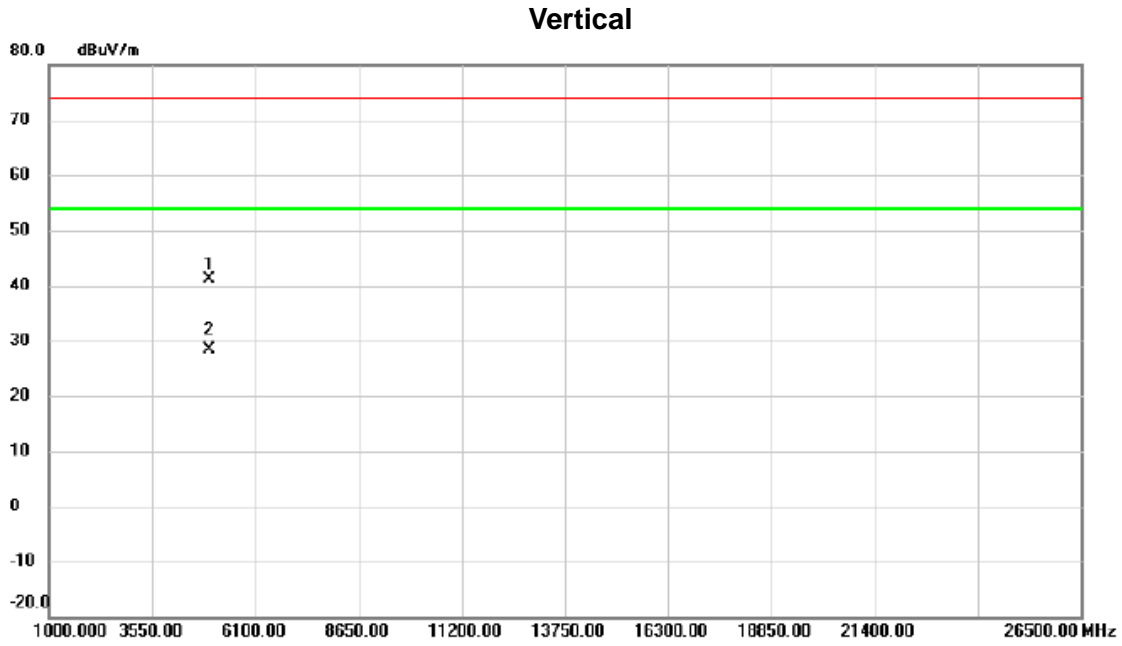

No.	Mk.	Freq. MHz	Reading Level dBuV	Correct Factor dB	Measure- ment dBuV/m	Limit dBuV/m	Margin dB	Detector	Comment
1		4958.965	50.21	-9.18	41.03	74.00	-32.97	peak	
2	*	4960.000	37.52	-9.17	28.35	54.00	-25.65	AVG	

**REMARKS:**

- (1) Measurement Value = Reading Level + Correct Factor.
- (2) Margin Level = Measurement Value - Limit Value.

Test Mode : TX 2480 MHz \_CH39\_1Mbps

### Horizontal

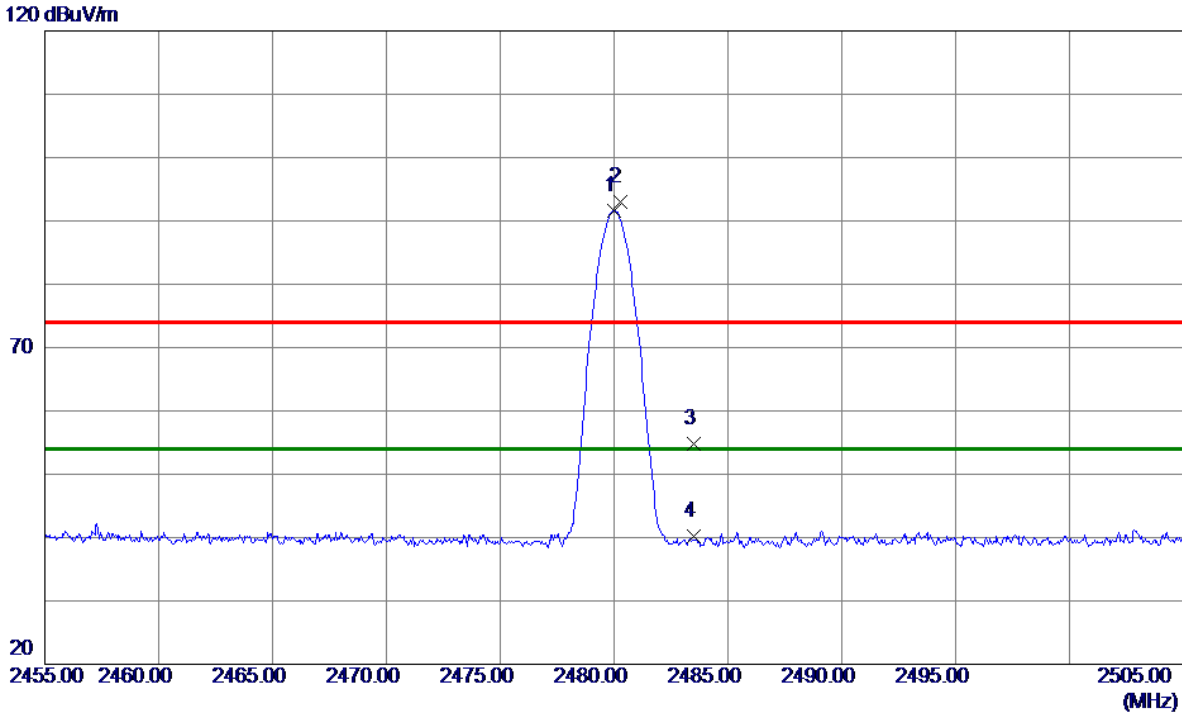

No.	Freq. MHz	Reading Level dBuV/m	Correct Factor dB	Measure ment dBuV/m	Limit dBuV/m	Margin dB	Detector	Comment
1 *	2480.0000	58.96	32.65	91.61	54.00	37.61	AVG	NO limit
2	2480.2500	60.33	32.65	92.98	74.00	18.98	Peak	NO limit
3	2483.5000	22.18	32.66	54.84	74.00	-19.16	Peak	
4	2483.5000	7.57	32.66	40.23	54.00	-13.77	AVG	

**REMARKS:**

- (1) Measurement Value = Reading Level + Correct Factor.
- (2) Margin Level = Measurement Value - Limit Value.

Test Mode : TX 2480 MHz \_CH39\_1Mbps

### Horizontal

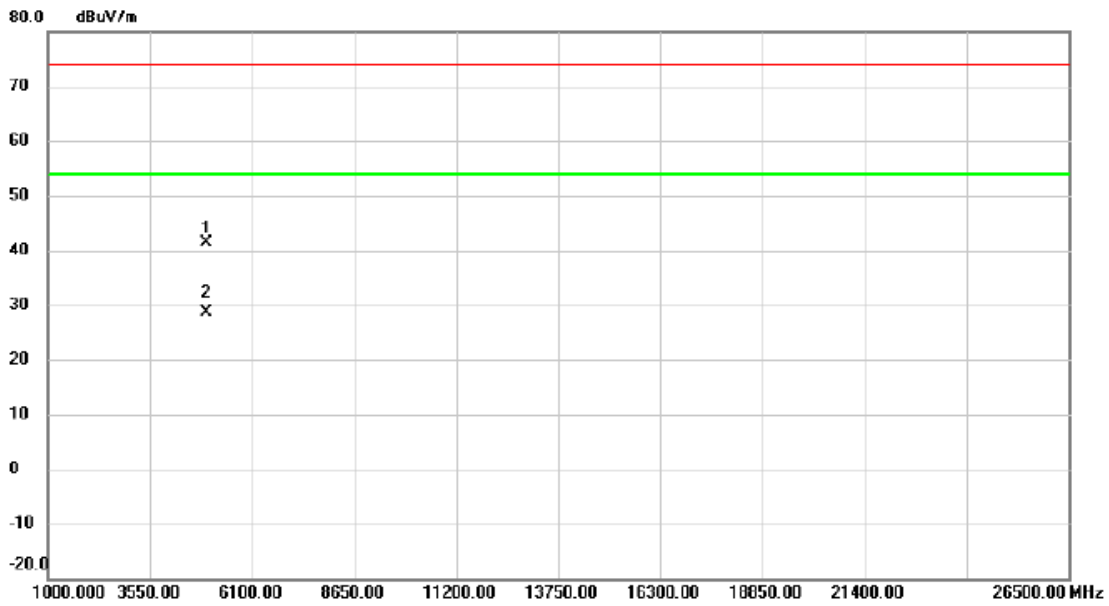

No.	Mk.	Freq. MHz	Reading Level dBuV	Correct Factor dB	Measure- ment dBuV/m	Limit dBuV/m	Margin dB	Detector	Comment
1		4958.025	50.57	-9.18	41.39	74.00	-32.61	peak	
2	*	4960.000	37.78	-9.17	28.61	54.00	-25.39	AVG	

**REMARKS:**

- (1) Measurement Value = Reading Level + Correct Factor.
- (2) Margin Level = Measurement Value - Limit Value.

Test Mode : TX 2402 MHz \_CH00\_2Mbps

### Vertical

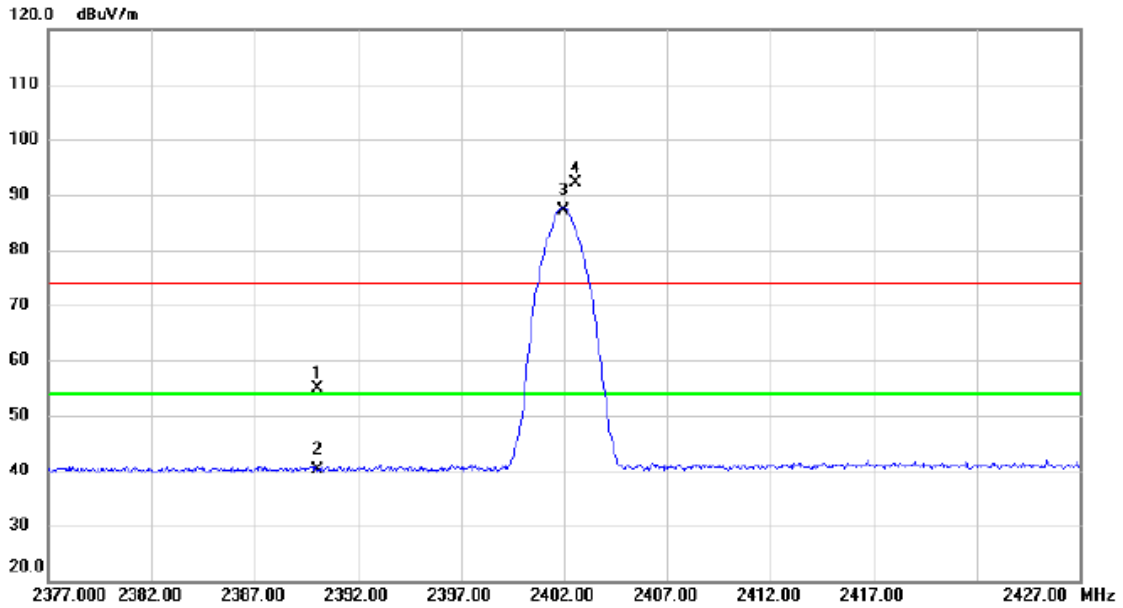

No.	Mk.	Freq.	Reading Level	Correct Factor	Measurement	Limit	Margin	Detector	Comment
		MHz	dBuV	dB	dBuV/m	dBuV/m	dB		
1		2390.000	22.52	32.39	54.91	74.00	-19.09	peak	
2		2390.000	7.62	32.39	40.01	54.00	-13.99	AVG	
3	*	2401.950	54.75	32.42	87.17	54.00	33.17	AVG	NO limit
4	X	2402.550	59.70	32.43	92.13	74.00	18.13	peak	NO limit

**REMARKS:**

- (1) Measurement Value = Reading Level + Correct Factor.
- (2) Margin Level = Measurement Value - Limit Value.



Test Mode : TX 2402 MHz \_CH00\_2Mbps

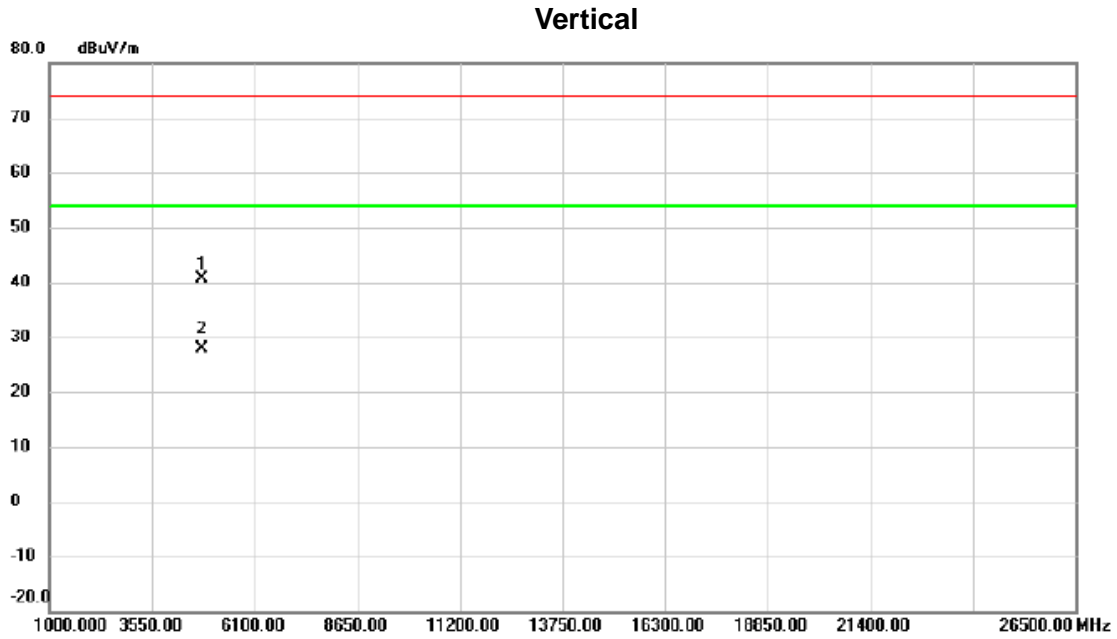

No.	Mk.	Freq. MHz	Reading Level dBuV	Correct Factor dB	Measure- ment dBuV/m	Limit dBuV/m	Margin dB	Detector	Comment
1		4802.080	50.39	-9.77	40.62	74.00	-33.38	peak	
2	*	4804.000	37.68	-9.77	27.91	54.00	-26.09	AVG	

**REMARKS:**

- (1) Measurement Value = Reading Level + Correct Factor.
- (2) Margin Level = Measurement Value - Limit Value.

Test Mode : TX 2402 MHz \_CH00\_2Mbps

### Horizontal

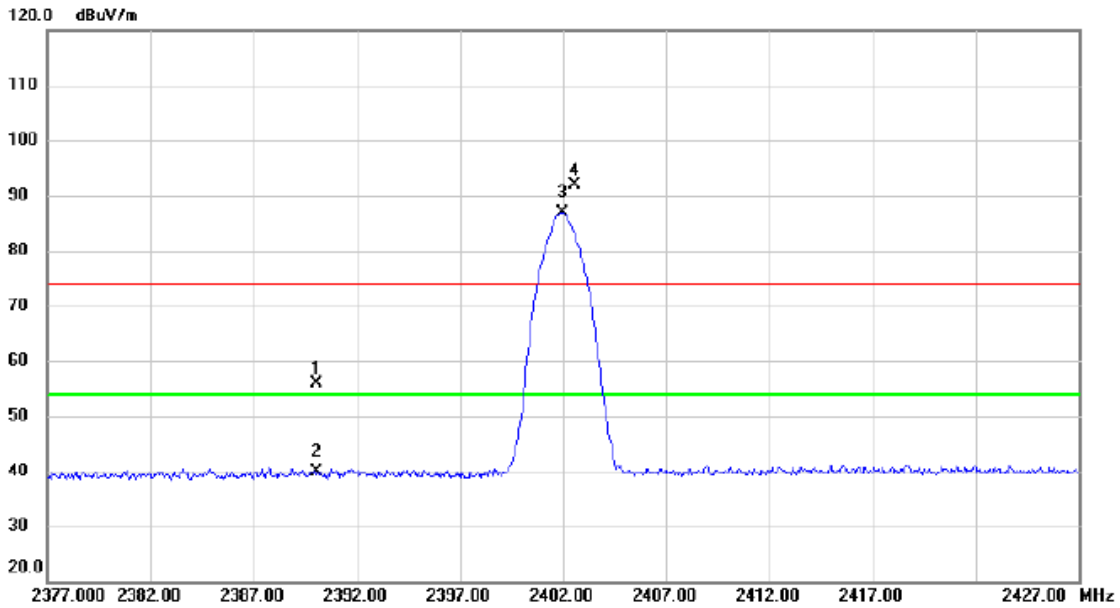

No.	Mk.	Freq. MHz	Reading Level dBuV	Correct Factor dB	Measure- ment dBuV/m	Limit dBuV/m	Margin dB	Detector	Comment
1		2390.000	23.49	32.39	55.88	74.00	-18.12	peak	
2		2390.000	7.47	32.39	39.86	54.00	-14.14	AVG	
3	*	2401.950	54.57	32.42	86.99	54.00	32.99	AVG	NO limit
4	X	2402.600	59.52	32.43	91.95	74.00	17.95	peak	NO limit

**REMARKS:**

(1) Measurement Value = Reading Level + Correct Factor.

(2) Margin Level = Measurement Value - Limit Value.

Test Mode : TX 2402 MHz \_CH00\_2Mbps

### Horizontal

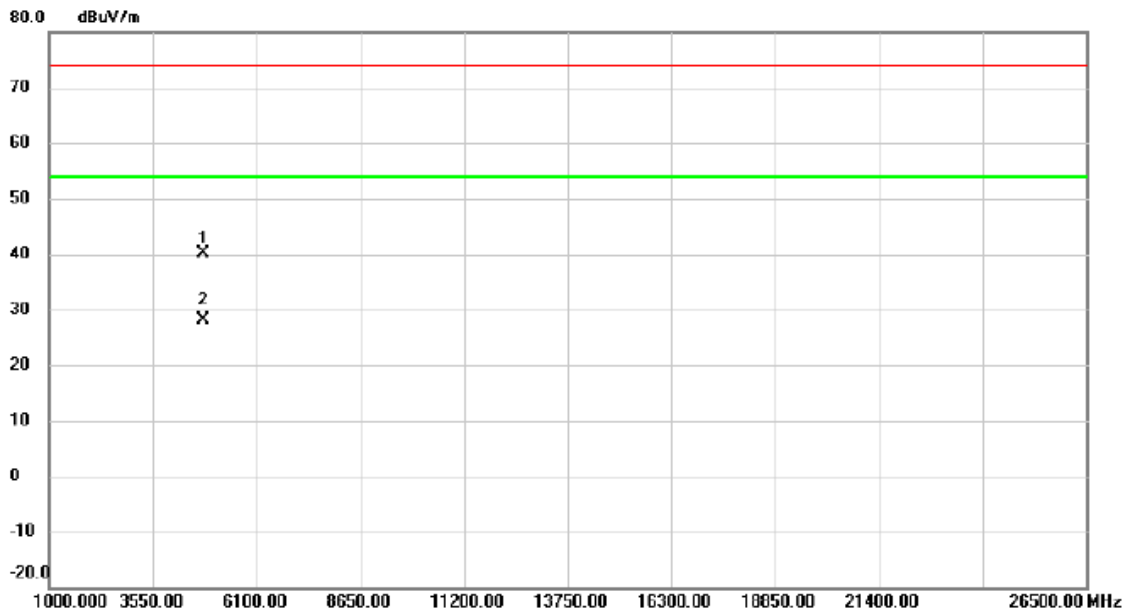

No.	Mk.	Freq. MHz	Reading Level dBuV	Correct Factor dB	Measure- ment dBuV/m	Limit dBuV/m	Margin dB	Detector	Comment
1		4803.210	50.02	-9.77	40.25	74.00	-33.75	peak	
2	*	4804.000	37.84	-9.77	28.07	54.00	-25.93	AVG	

**REMARKS:**

- (1) Measurement Value = Reading Level + Correct Factor.
- (2) Margin Level = Measurement Value - Limit Value.

Test Mode : TX 2440 MHz \_CH19\_2Mbps

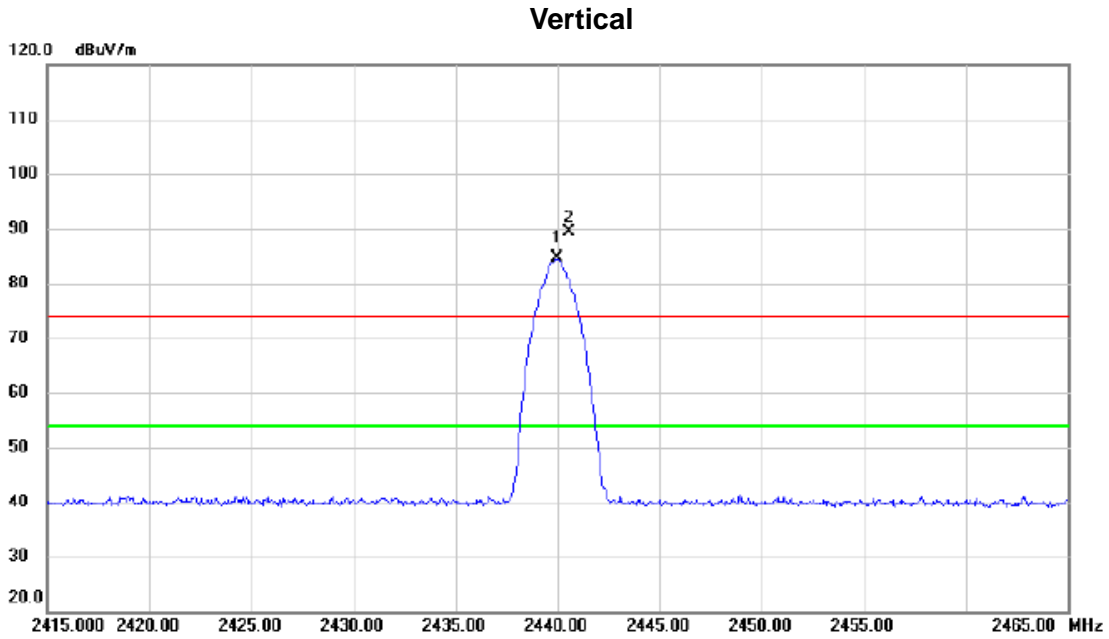

No.	Mk.	Freq. MHz	Reading Level dBuV	Correct Factor dB	Measure- ment dBuV/m	Limit dBuV/m	Margin dB	Detector	Comment
1	*	2439.950	52.03	32.53	84.56	54.00	30.56	AVG	NO limit
2	X	2440.600	56.96	32.53	89.49	74.00	15.49	peak	NO limit

**REMARKS:**

- (1) Measurement Value = Reading Level + Correct Factor.
- (2) Margin Level = Measurement Value - Limit Value.

Test Mode : TX 2440 MHz \_CH19\_2Mbps

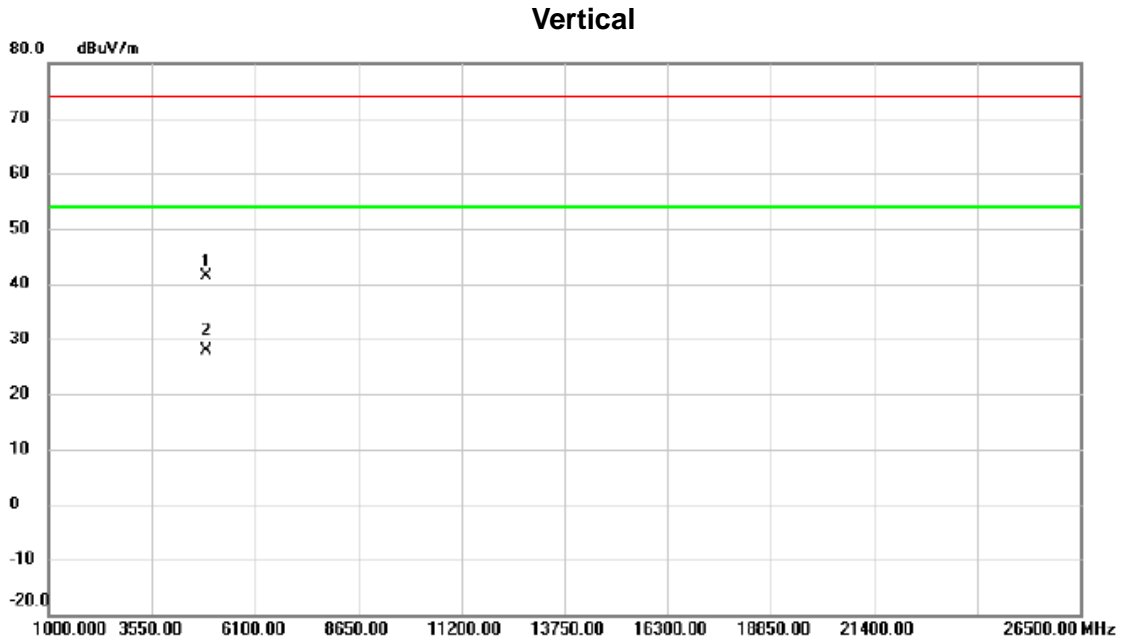

No. Mk.	Freq. MHz	Reading Level dBuV	Correct Factor dB	Measure- ment dBuV/m	Limit dBuV/m	Margin dB	Detector	Comment
1	4879.645	50.92	-9.48	41.44	74.00	-32.56	peak	
2 *	4882.000	37.38	-9.47	27.91	54.00	-26.09	AVG	

**REMARKS:**

- (1) Measurement Value = Reading Level + Correct Factor.
- (2) Margin Level = Measurement Value - Limit Value.

Test Mode : TX 2440 MHz \_CH19\_2Mbps

### Horizontal

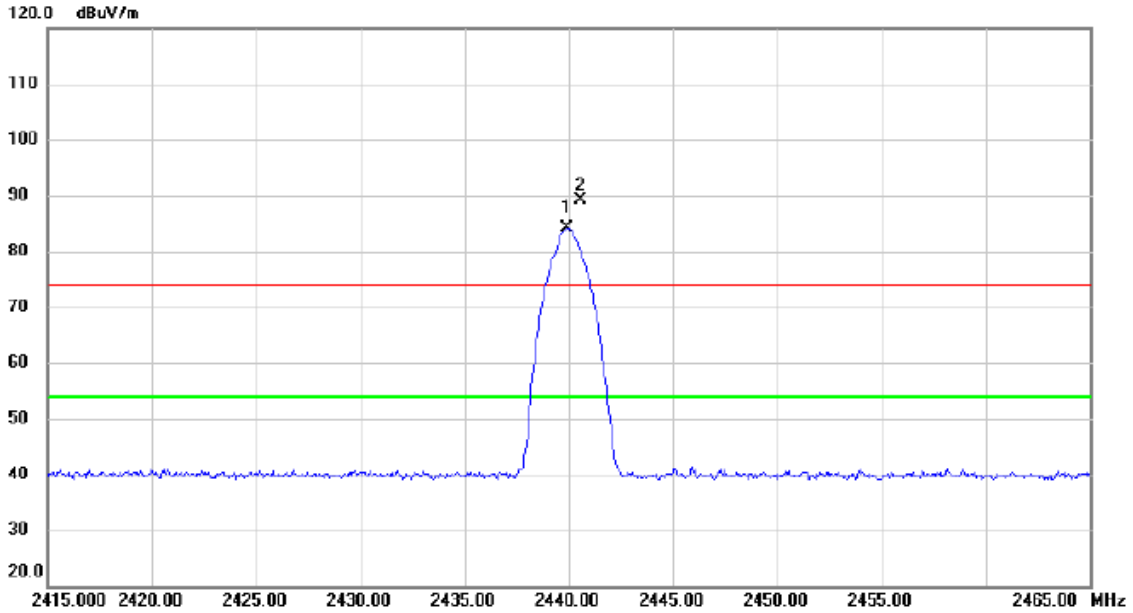

No.	Mk.	Freq. MHz	Reading Level dBuV	Correct Factor dB	Measure- ment dBuV/m	Limit dBuV/m	Margin dB	Detector	Comment
1	*	2439.900	51.57	32.53	84.10	54.00	30.10	AVG	NO limit
2	X	2440.550	56.51	32.53	89.04	74.00	15.04	peak	NO limit

**REMARKS:**

- (1) Measurement Value = Reading Level + Correct Factor.
- (2) Margin Level = Measurement Value - Limit Value.

Test Mode : TX 2440 MHz \_CH19\_2Mbps

### Horizontal

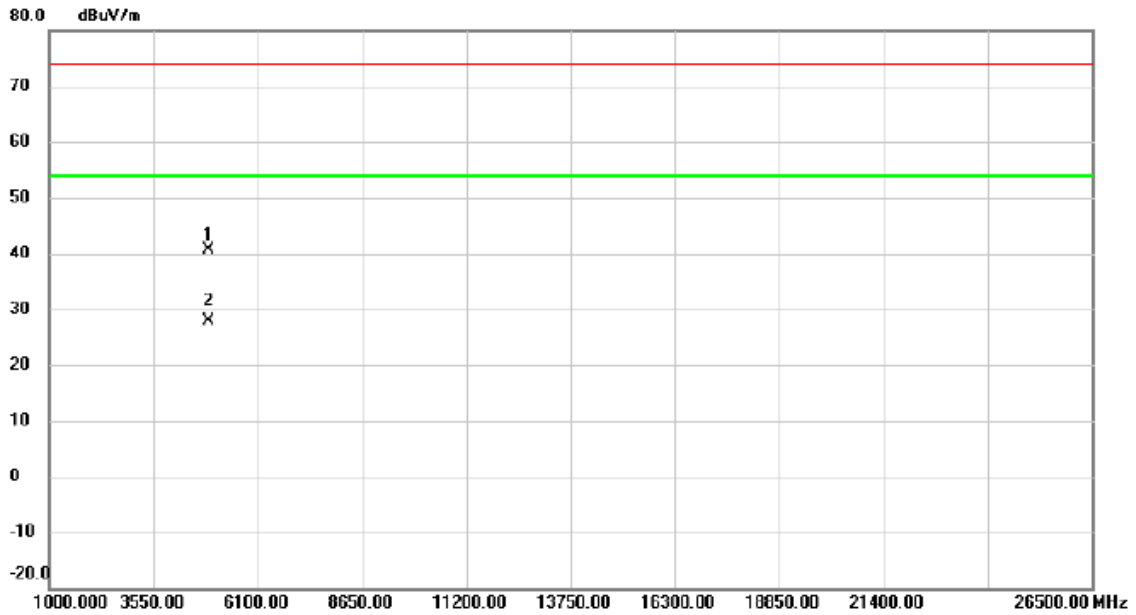

No.	Mk.	Freq. MHz	Reading Level dBuV	Correct Factor dB	Measure- ment dBuV/m	Limit dBuV/m	Margin dB	Detector	Comment
1		4881.550	50.11	-9.47	40.64	74.00	-33.36	peak	
2	*	4882.000	37.33	-9.47	27.86	54.00	-26.14	AVG	

**REMARKS:**

- (1) Measurement Value = Reading Level + Correct Factor.
- (2) Margin Level = Measurement Value - Limit Value.

Test Mode : TX 2480 MHz \_CH39\_2Mbps

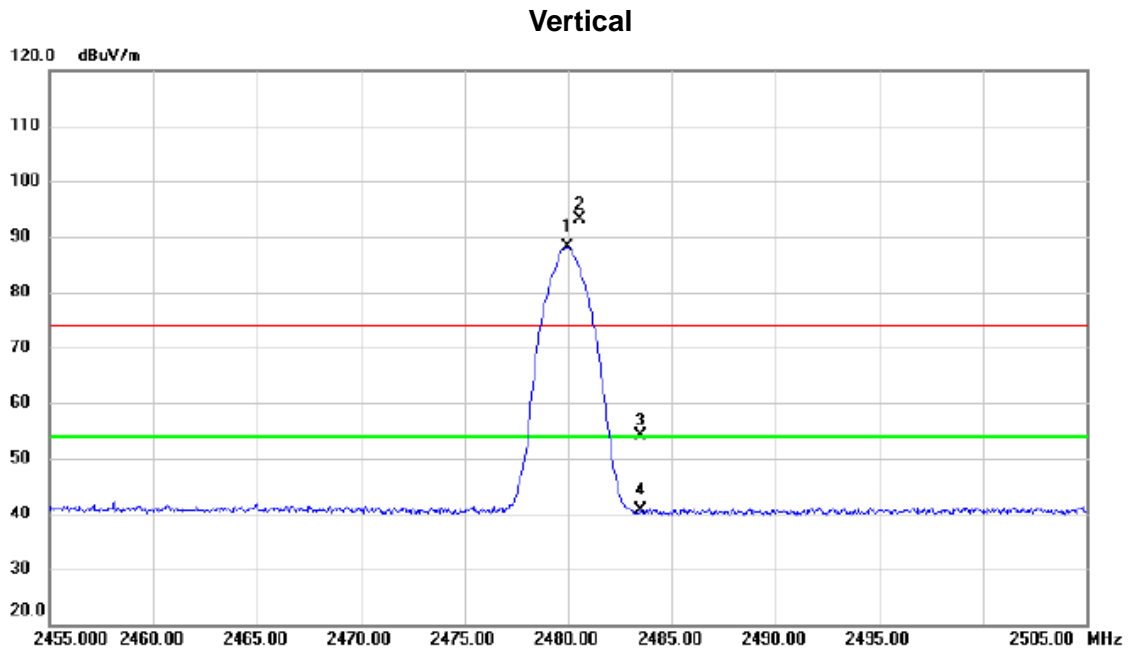

No.	Mk.	Freq. MHz	Reading Level dBuV	Correct Factor dB	Measure- ment dBuV/m	Limit dBuV/m	Margin dB	Detector	Comment
1	*	2479.950	55.58	32.65	88.23	54.00	34.23	AVG	NO limit
2	X	2480.550	60.47	32.66	93.13	74.00	19.13	peak	NO limit
3		2483.500	21.59	32.66	54.25	74.00	-19.75	peak	
4		2483.500	7.93	32.66	40.59	54.00	-13.41	AVG	

**REMARKS:**

- (1) Measurement Value = Reading Level + Correct Factor.
- (2) Margin Level = Measurement Value - Limit Value.



Test Mode : TX 2480 MHz \_CH39\_2Mbps

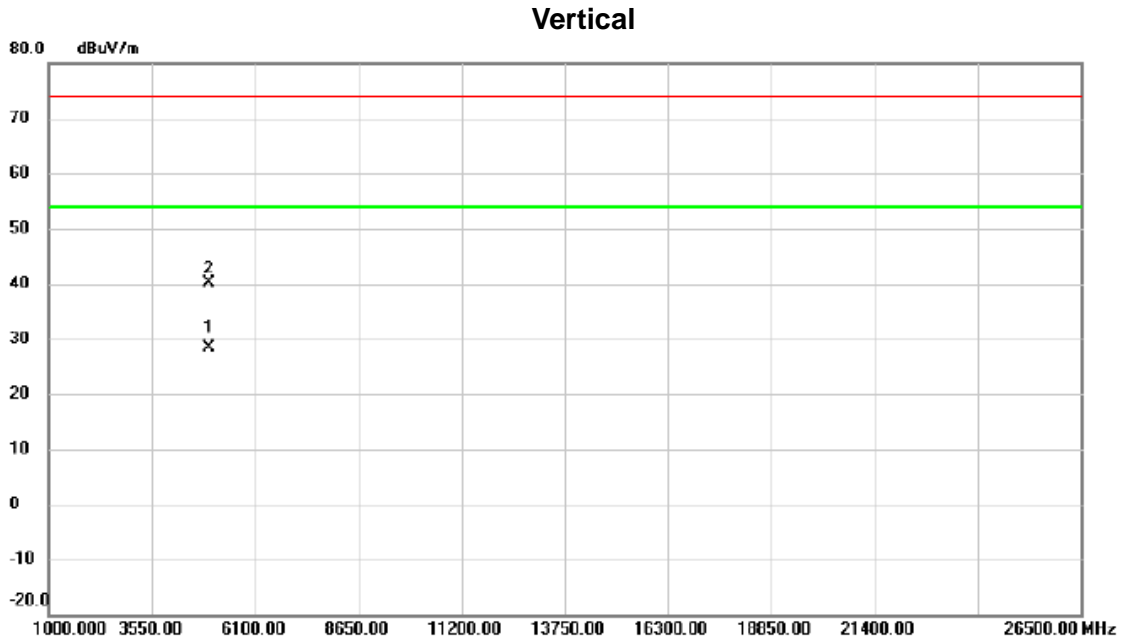

No.	Mk.	Freq. MHz	Reading Level dBuV	Correct Factor dB	Measure- ment dBuV/m	Limit dBuV/m	Margin dB	Detector	Comment
1	*	4960.000	37.52	-9.17	28.35	54.00	-25.65	AVG	
2		4965.150	49.36	-9.15	40.21	74.00	-33.79	peak	

**REMARKS:**

- (1) Measurement Value = Reading Level + Correct Factor.
- (2) Margin Level = Measurement Value - Limit Value.

Test Mode : TX 2480 MHz \_CH39\_2Mbps

### Horizontal

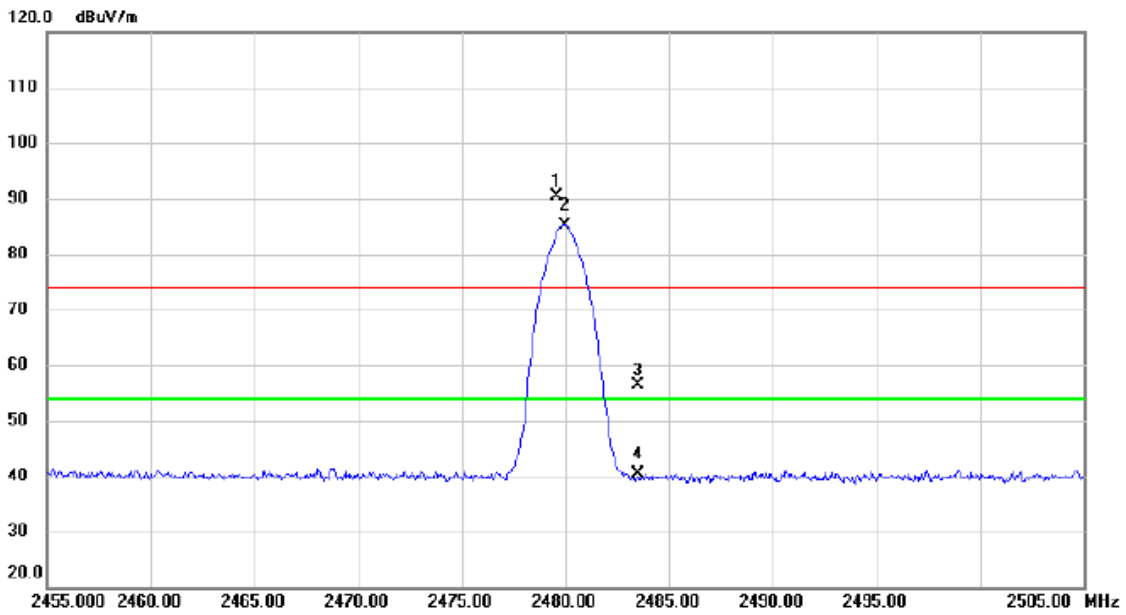

No.	Mk.	Freq. MHz	Reading Level dBuV	Correct Factor dB	Measure- ment dBuV/m	Limit dBuV/m	Margin dB	Detector	Comment
1	X	2479.550	57.83	32.65	90.48	74.00	16.48	peak	NO limit
2	*	2479.950	52.52	32.65	85.17	54.00	31.17	AVG	NO limit
3		2483.500	23.78	32.66	56.44	74.00	-17.56	peak	
4		2483.500	7.68	32.66	40.34	54.00	-13.66	AVG	

**REMARKS:**

- (1) Measurement Value = Reading Level + Correct Factor.
- (2) Margin Level = Measurement Value - Limit Value.

Test Mode : TX 2480 MHz \_CH39\_2Mbps

### Horizontal

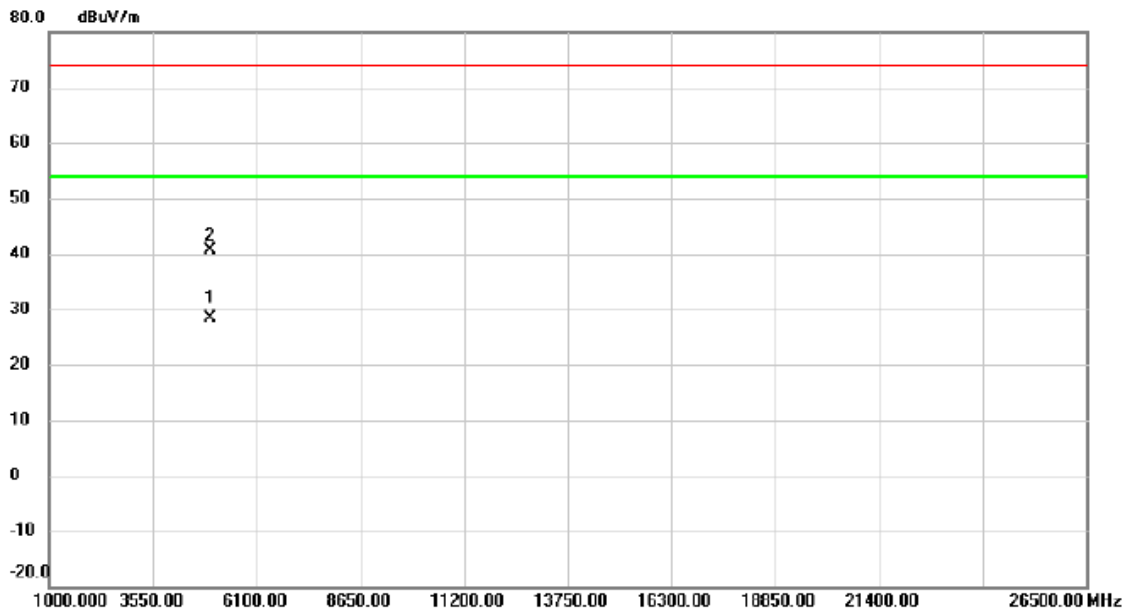

No.	Mk.	Freq. MHz	Reading Level dBuV	Correct Factor dB	Measure- ment dBuV/m	Limit dBuV/m	Margin dB	Detector	Comment
1	*	4960.000	37.46	-9.17	28.29	54.00	-25.71	AVG	
2		4961.530	49.83	-9.17	40.66	74.00	-33.34	peak	

**REMARKS:**

- (1) Measurement Value = Reading Level + Correct Factor.
- (2) Margin Level = Measurement Value - Limit Value.

## APPENDIX E - BANDWIDTH

Test Mode: CH00, CH19 , CH39 - 1Mbps

Channel	Frequency (MHz)	6 dB Bandwidth (MHz)	99 % Emission Bandwidth (MHz)	6 dB Bandwidth Min. Limit (kHz)	Test Result
00	2402	0.657	1.040	500	Pass
19	2440	0.660	1.040	500	Pass
39	2480	0.662	1.040	500	Pass

### 6dB Bandwidth

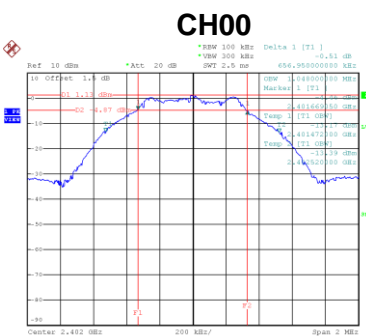

Date: 22.AUG.2019 19:27:28

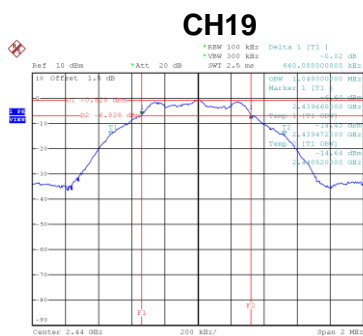

Date: 22.AUG.2019 19:29:31

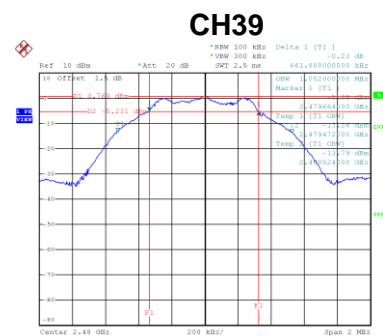

Date: 22.AUG.2019 19:31:39

### 99 % Emission Bandwidth

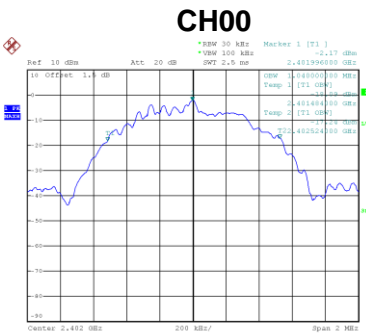

Date: 18.SEP.2019 16:28:25

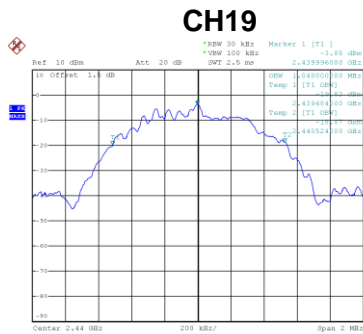

Date: 18.SEP.2019 16:30:09

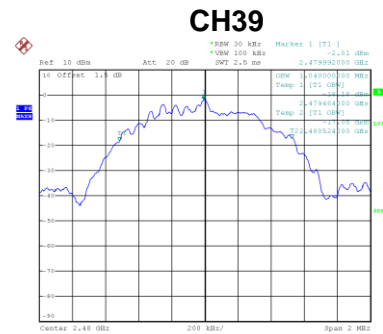

Date: 18.SEP.2019 16:30:50

Test Mode: CH00, CH19 , CH39 - 2Mbps

Channel	Frequency (MHz)	6 dB Bandwidth (MHz)	99 % Emission Bandwidth (MHz)	6 dB Bandwidth Min. Limit (kHz)	Test Result
00	2402	1.150	2.040	500	Pass
19	2440	1.148	2.040	500	Pass
39	2480	1.114	2.048	500	Pass

### 6dB Bandwidth

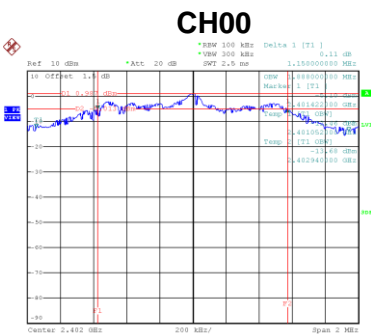

Date: 22.AUG.2019 19:36:37

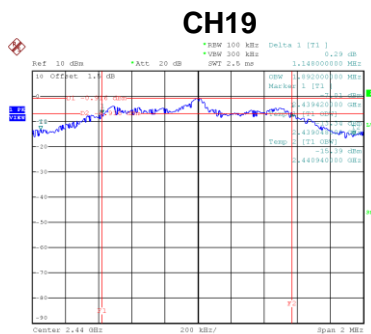

Date: 22.AUG.2019 19:38:05

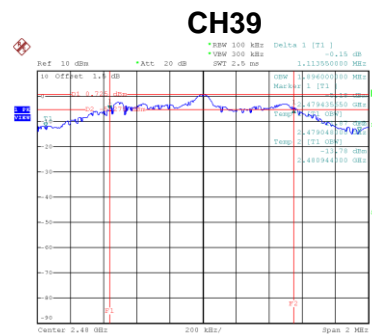

Date: 22.AUG.2019 19:40:09

### 99 % Emission Bandwidth

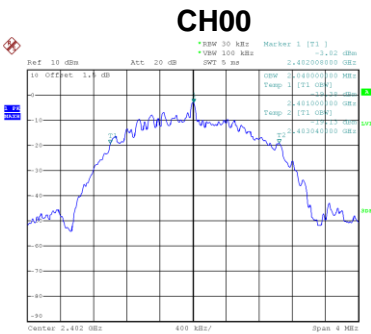

Date: 18.SEP.2019 16:35:05

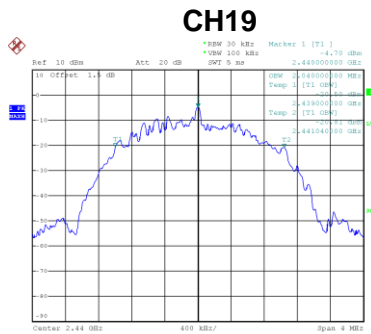

Date: 18.SEP.2019 16:34:31



Date: 18.SEP.2019 16:33:31

## **APPENDIX F - MAXIMUM OUTPUT POWER & E.I.R.P.**

Test Mode : CH00, CH19 , CH39 - 1Mbps

Frequency (MHz)	Output Power (dBm)	Output Power (W)	Max. Limit (dBm)	Max. Limit (W)	Test Result
2402	1.41	0.0014	30.00	1.00	Pass
2440	-0.38	0.0009	30.00	1.00	Pass
2480	1.13	0.0013	30.00	1.00	Pass

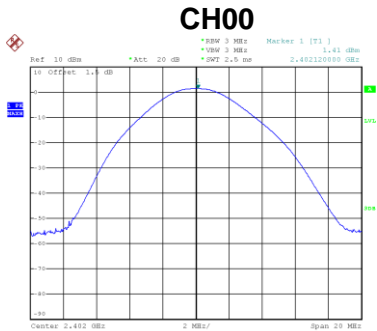

Date: 22.AUG.2019 19:51:52

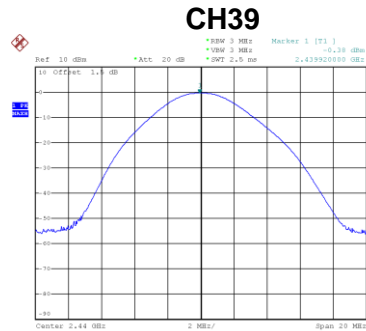

Date: 22.AUG.2019 19:52:41

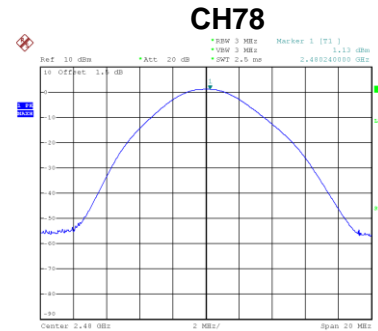

Date: 22.AUG.2019 19:54:00

Test Mode : CH00, CH19 , CH39 - 2Mbps

Frequency (MHz)	Output Power (dBm)	Output Power (W)	Max. Limit (dBm)	Max. Limit (W)	Test Result
2402	1.53	0.0014	30.00	1.00	Pass
2440	-0.28	0.0009	30.00	1.00	Pass
2480	1.23	0.0013	30.00	1.00	Pass

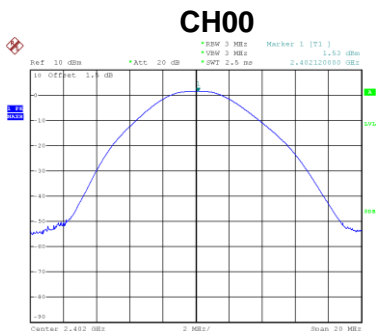

Date: 22.AUG.2019 19:49:26

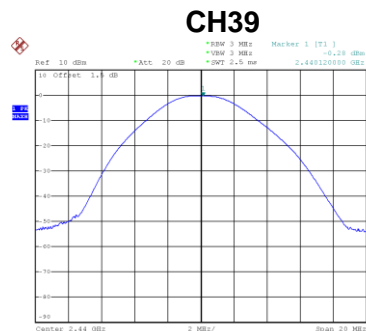

Date: 22.AUG.2019 19:49:20

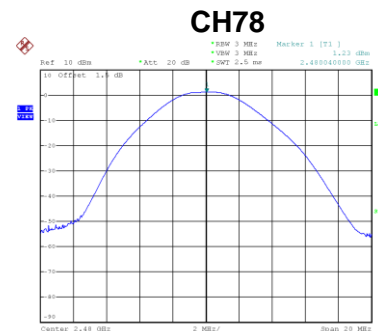

Date: 22.AUG.2019 19:46:52



## **APPENDIX G - CONDUCTED SPURIOUS EMISSION**

Test Mode : CH00, CH19 , CH39 - 1Mbps

### Bandedge- CH00 (Lower)

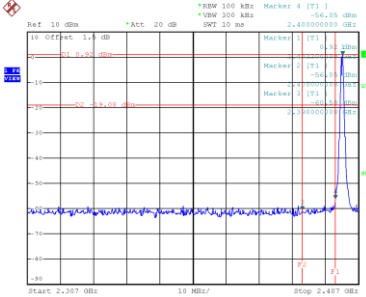

Date: 22.AUG.2019 19:27:51

### Bandedge CH39 (Upper)

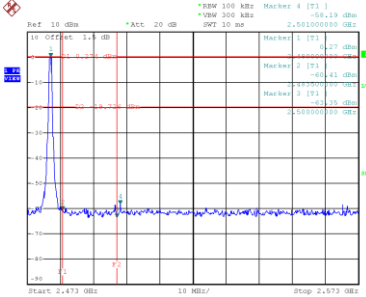

Date: 22.AUG.2019 19:32:03

### CH00 – 10th Harmonic of the fundamental frequency

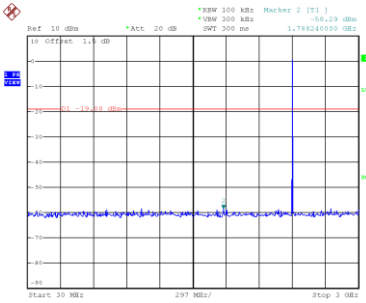

Date: 22.AUG.2019 19:28:04

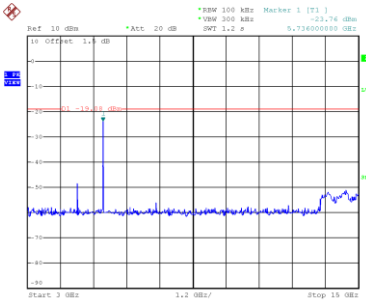

Date: 22.AUG.2019 19:28:11

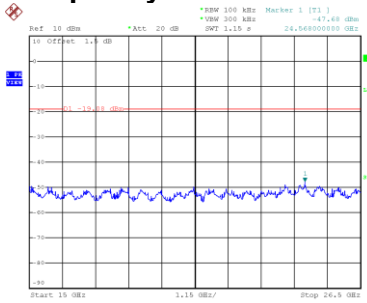

Date: 22.AUG.2019 19:28:18

### CH19 – 10th Harmonic of the fundamental frequency

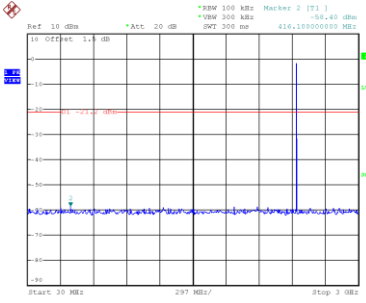

Date: 22.AUG.2019 19:30:07

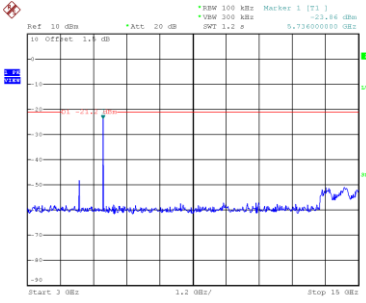

Date: 22.AUG.2019 19:30:14

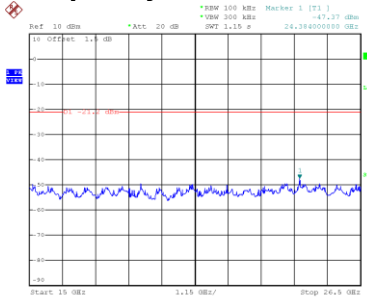

Date: 22.AUG.2019 19:30:20

### CH39 – 10th Harmonic of the fundamental frequency

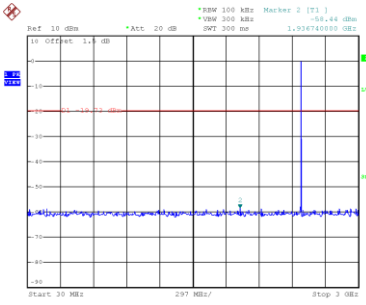

Date: 22.AUG.2019 19:32:16

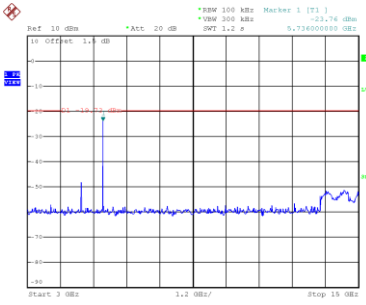

Date: 22.AUG.2019 19:32:22

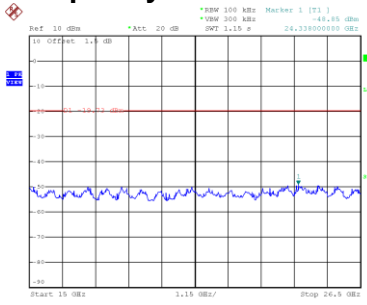

Date: 22.AUG.2019 19:32:29

Test Mode : CH00, CH19 , CH39 - 2Mbps

### Bandedge- CH00 (Lower)

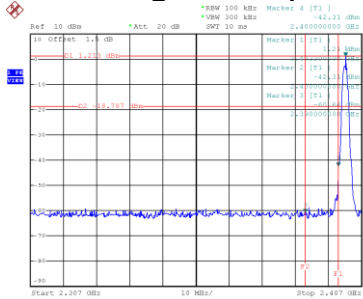

Date: 22.AUG.2019 19:136144

### Bandedge CH39 (Upper)

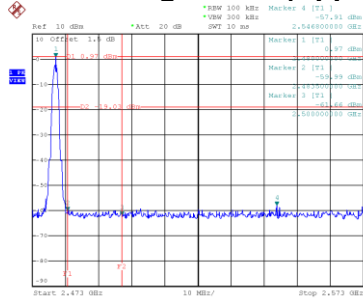

Date: 22.AUG.2019 19:140116

### CH00 – 10th Harmonic of the fundamental frequency

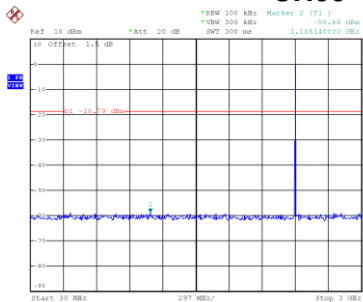

Date: 22.AUG.2019 19:136157

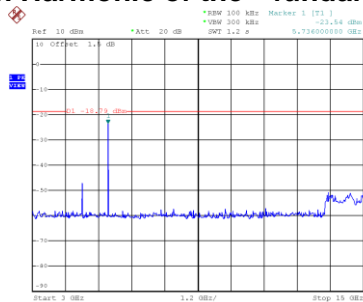

Date: 22.AUG.2019 19:137104

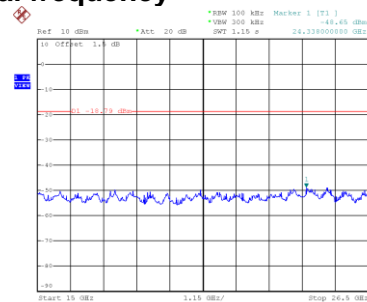

Date: 22.AUG.2019 19:137110

### CH19 – 10th Harmonic of the fundamental frequency

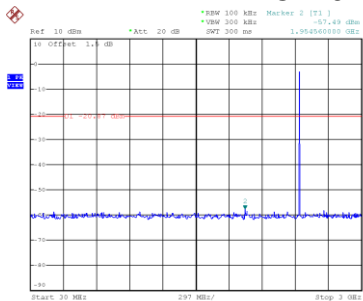

Date: 22.AUG.2019 19:138146

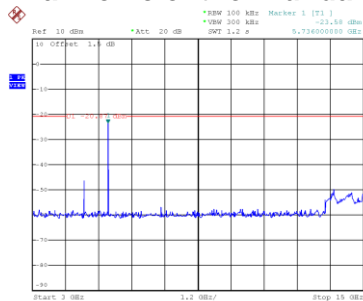

Date: 22.AUG.2019 19:138153

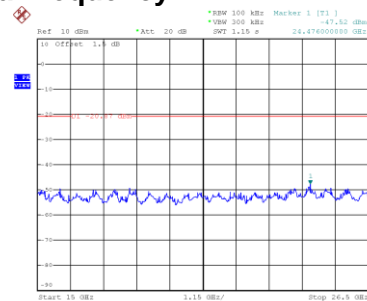

Date: 22.AUG.2019 19:139100

### CH39 – 10th Harmonic of the fundamental frequency

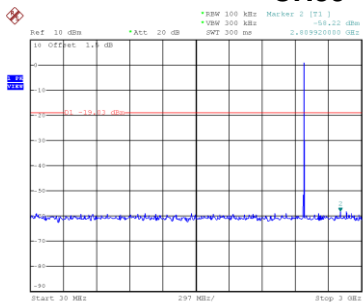

Date: 22.AUG.2019 19:140129

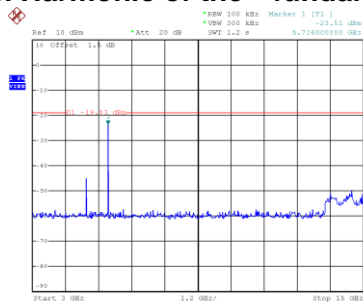

Date: 22.AUG.2019 19:140136

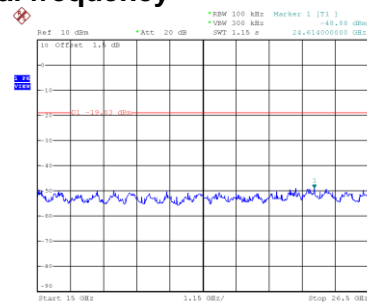

Date: 22.AUG.2019 19:140142

## APPENDIX H - POWER SPECTRAL DENSITY

Test Mode: CH00, CH19, CH39 - 1Mbps

Channel	Frequency (MHz)	Power Spectral Density (dBm/3 kHz)	Max. Limit (dBm/3 kHz)	Test Result
00	2402	-14.030	8.00	Pass
19	2440	-15.680	8.00	Pass
39	2480	-14.150	8.00	Pass

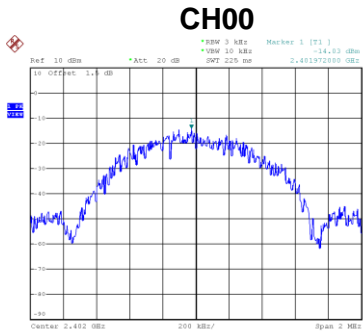

Date: 22.AUG.2019 19:28:23

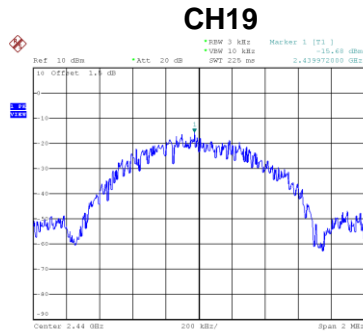

Date: 22.AUG.2019 19:30:26

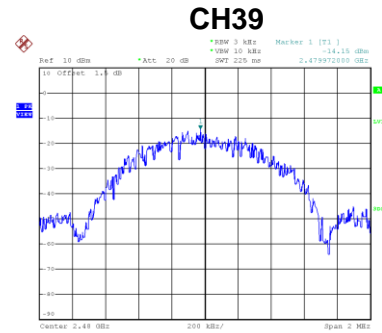

Date: 22.AUG.2019 19:33:12

Test Mode: CH00, CH19, CH39 - 2Mbps

Channel	Frequency (MHz)	Power Spectral Density (dBm/3 kHz)	Max. Limit (dBm/3 kHz)	Test Result
00	2402	-17.390	8.00	Pass
19	2440	-19.310	8.00	Pass
39	2480	-17.630	8.00	Pass

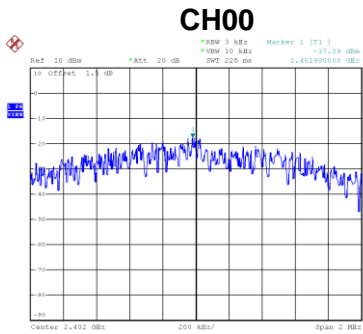

Date: 22.AUG.2019 19:37:16

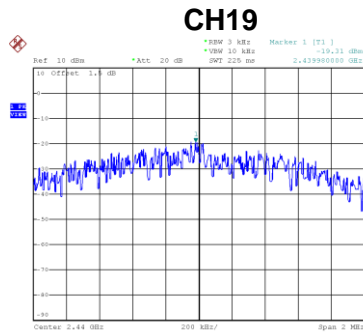

Date: 22.AUG.2019 19:39:05

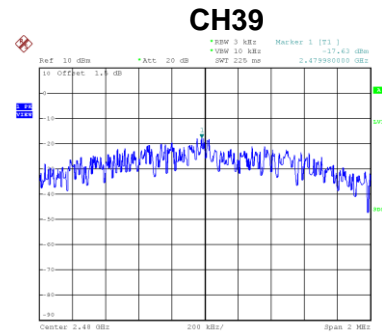

Date: 22.AUG.2019 19:40:46

End of Test Report