

RF Exposure Lab

Plot 9

DUT: Dipole D5GHzV2; Type: D5GHzV2; Serial: D5GHzV2 - SN:1085

Communication System: CW; Frequency: 5600 MHz; Duty Cycle: 1:1
 Medium: MSL 3-6 GHz; Medium parameters used: $f = 5600$ MHz; $\sigma = 5.73$ S/m; $\epsilon_r = 48.47$; $\rho = 1000$ kg/m³
 Phantom section: Flat Section

Test Date: Date: 4/10/2019; Ambient Temp: 23 °C; Tissue Temp: 21 °C
 Probe: EX3DV4 - SN3693; ConvF(3.91, 3.91, 3.91); Calibrated: 8/27/2018;
 Sensor-Surface: 2mm (Mechanical Surface Detection)
 Electronics: DAE4 Sn1217; Calibrated: 2/15/2019
 Phantom: ELI v4.0; Type: QDOVA001BB; Serial: 1065
 Measurement SW: DASY52, Version 52.10 (0); SEMCAD X Version 14.6.10 (7417)

Procedure Notes:

5600 MHz Body/Verification/Area Scan (61x81x1): Interpolated grid: dx=1.000 mm, dy=1.000 mm
 Maximum value of SAR (interpolated) = 1.68 W/kg

5600 MHz Body/Verification/Zoom Scan (7x7x12)/Cube 0: Measurement grid: dx=4mm, dy=4mm, dz=2mm
 Reference Value = 55.852 V/m; Power Drift = -0.01 dB
 Peak SAR (extrapolated) = 3.37 W/kg
SAR(1 g) = 0.806 W/kg; SAR(10 g) = 0.228 W/kg
 Maximum value of SAR (measured) = 1.71 W/kg

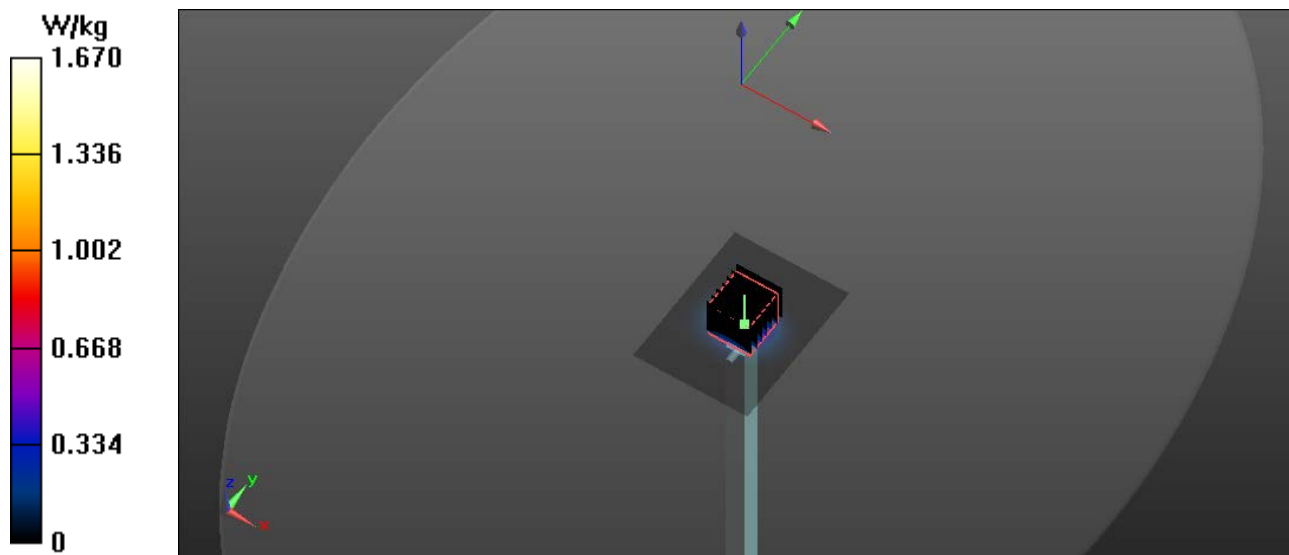

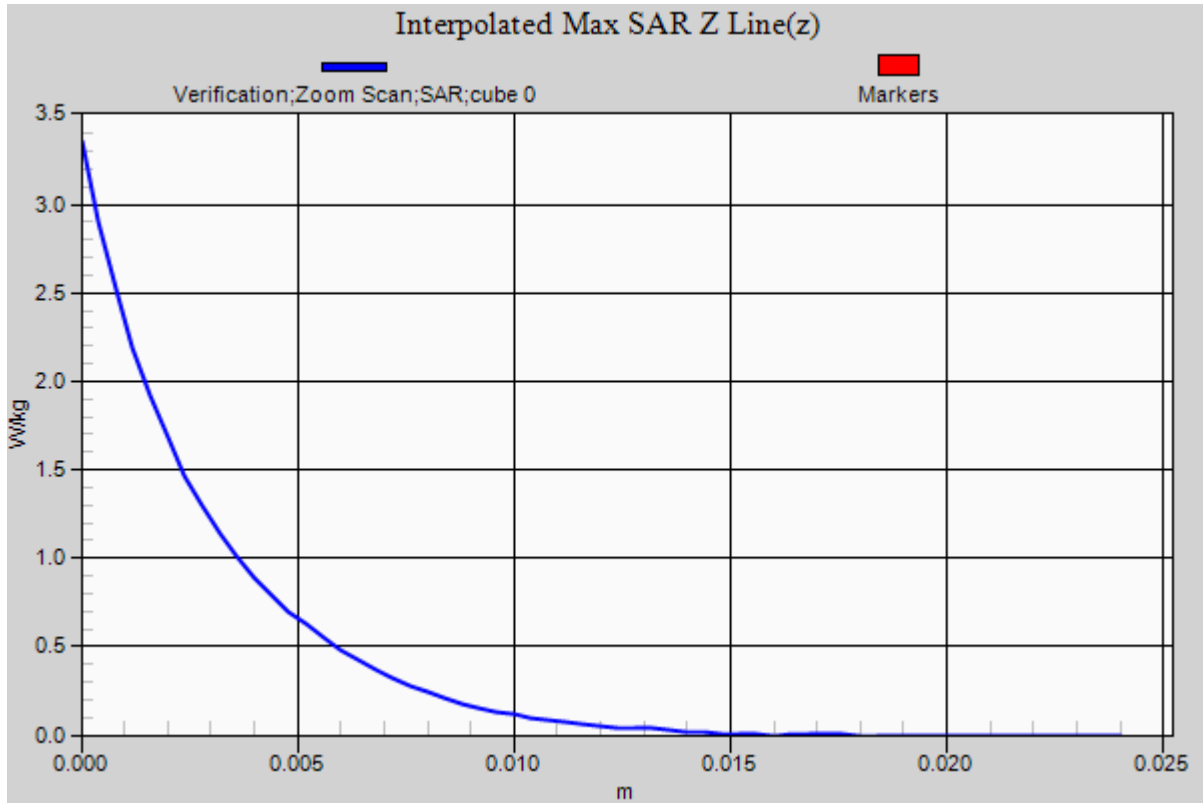

RF Exposure Lab

Plot 10

DUT: Dipole D5GHzV2; Type: D5GHzV2; Serial: D5GHzV2 - SN:1085

Communication System: CW; Frequency: 5750 MHz; Duty Cycle: 1:1
 Medium: MSL 3-6 GHz; Medium parameters used (interpolated): $f = 5750$ MHz; $\sigma = 5.925$ S/m; $\epsilon_r = 48.245$; $\rho = 1000$ kg/m³
 Phantom section: Flat Section

Test Date: Date: 4/10/2019; Ambient Temp: 23 °C; Tissue Temp: 21 °C
 Probe: EX3DV4 - SN3693; ConvF(4.05, 4.05, 4.05); Calibrated: 8/27/2018;
 Sensor-Surface: 2mm (Mechanical Surface Detection)
 Electronics: DAE4 Sn1217; Calibrated: 2/15/2019
 Phantom: ELI v4.0; Type: QDOVA001BB; Serial: 1065
 Measurement SW: DASY52, Version 52.10 (0); SEMCAD X Version 14.6.10 (7417)

Procedure Notes:

5750 MHz Body/Verification/Area Scan (7x9x1): Measurement grid: dx=10mm, dy=10mm

[Info: Interpolated medium parameters used for SAR evaluation.](#)

Maximum value of SAR (measured) = 1.56 W/kg

5750 MHz Body/Verification/Zoom Scan (7x7x12)/Cube 0: Measurement grid: dx=4mm, dy=4mm, dz=2mm

Reference Value = 11.621 V/m; Power Drift = -0.01 dB

Peak SAR (extrapolated) = 3.47 W/kg

SAR(1 g) = 0.772 W/kg; SAR(10 g) = 0.218 W/kg

[Info: Interpolated medium parameters used for SAR evaluation.](#)

Maximum value of SAR (measured) = 1.63 W/kg

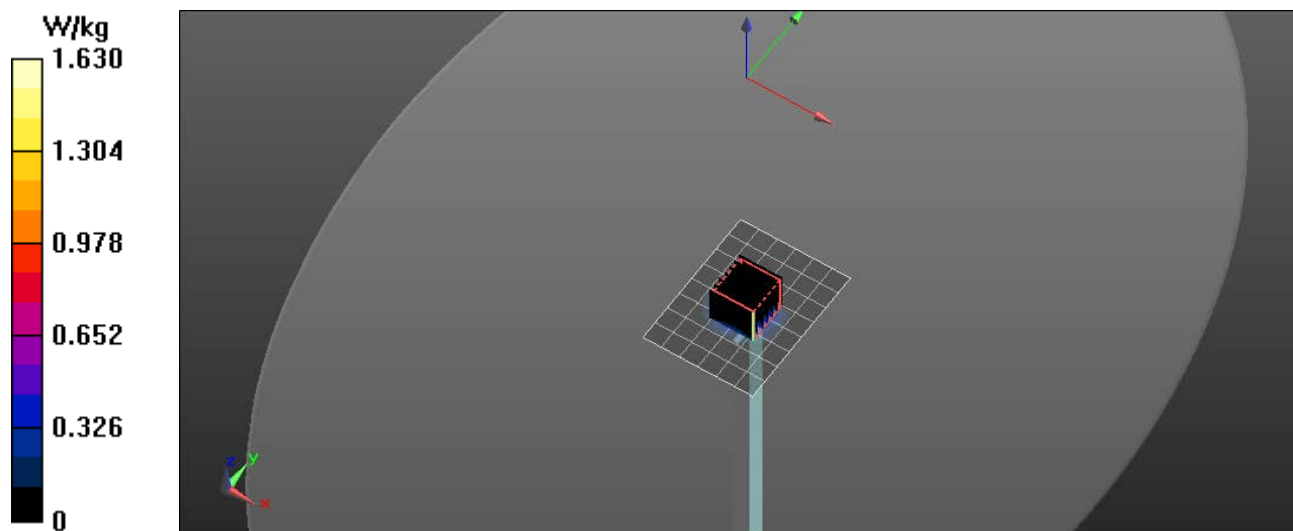

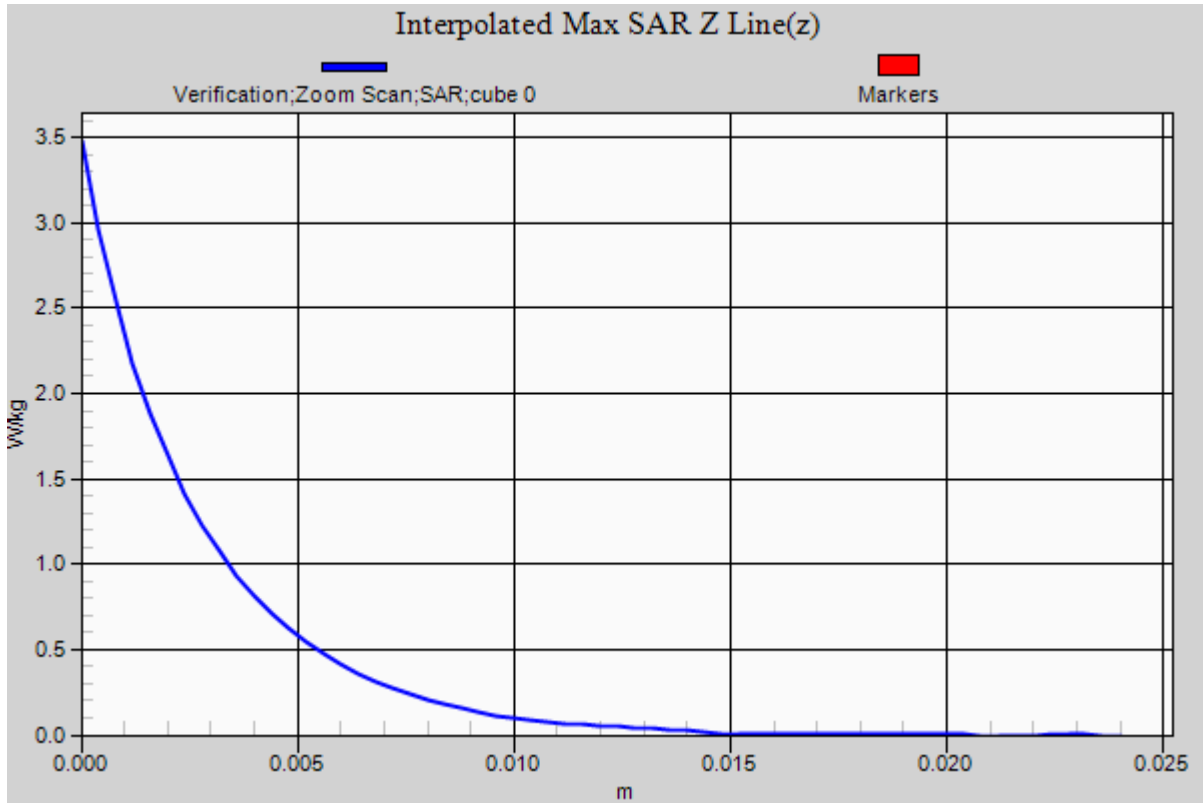

Appendix B – SAR Test Data Plots

RF Exposure Lab

Plot 1

DUT: MS3; Type: Tablet Computer; Serial: MS3W-C08

Communication System: LTE (SC-FDMA, 1 RB, 10 MHz, QPSK); Frequency: 707.5 MHz; Duty Cycle: 1:1
 Medium: MSL750; Medium parameters used (interpolated): $f = 707.5$ MHz; $\sigma = 0.978$ S/m; $\epsilon_r = 55.698$; $\rho = 1000$ kg/m³
 Phantom section: Flat Section

Test Date: Date: 4/10/2019; Ambient Temp: 23 °C; Tissue Temp: 21 °C

Probe: EX3DV4 - SN3693; ConvF(9.64, 9.64, 9.64); Calibrated: 8/27/2018;
 Sensor-Surface: 2mm (Mechanical Surface Detection)
 Electronics: DAE4 Sn1217; Calibrated: 2/15/2019
 Phantom: ELI v4.0; Type: QDOVA001BB; Serial: 1065
 Measurement SW: DASY52, Version 52.10 (0); SEMCAD X Version 14.6.10 (7417)

Procedure Notes:

B12 LTE/Right Mid 1 RB 24 Offset/Area Scan (7x9x1): Measurement grid: dx=15mm, dy=15mm

[Info: Interpolated medium parameters used for SAR evaluation.](#)

Maximum value of SAR (measured) = 1.11 W/kg

B12 LTE/Right Mid 1 RB 24 Offset/Zoom Scan (5x5x7)/Cube 0: Measurement grid: dx=8mm, dy=8mm, dz=5mm

Reference Value = 20.48 V/m; Power Drift = 0.03 dB

Peak SAR (extrapolated) = 1.53 W/kg

SAR(1 g) = 0.860 W/kg; SAR(10 g) = 0.506 W/kg

[Info: Interpolated medium parameters used for SAR evaluation.](#)

Maximum value of SAR (measured) = 1.15 W/kg

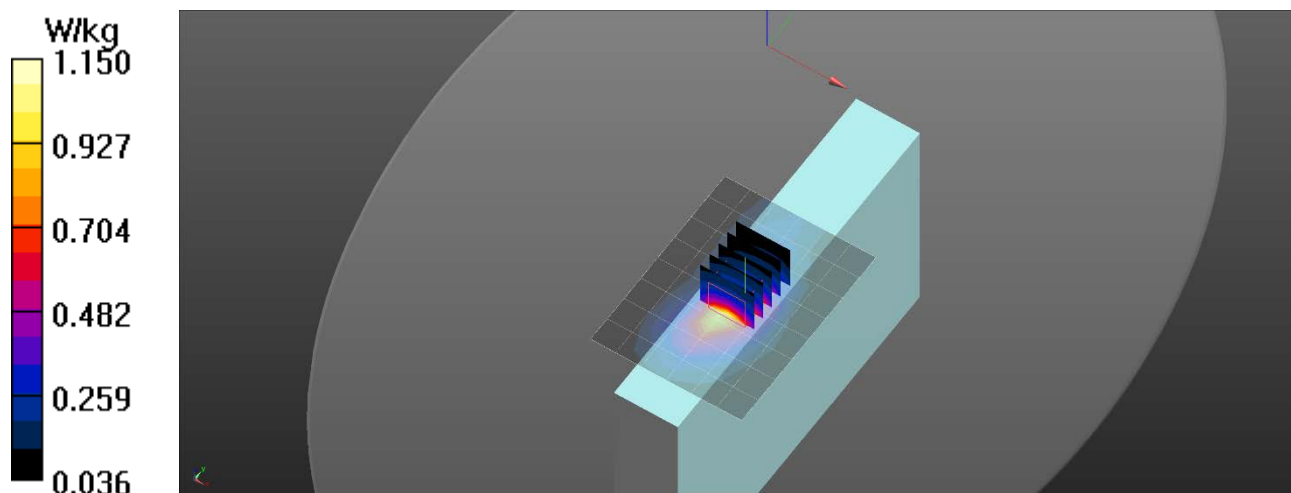

RF Exposure Lab

Plot 2

DUT: MS3; Type: Tablet Computer; Serial: MS3W-C08

Communication System: LTE (SC-FDMA, 1 RB, 10 MHz, QPSK); Frequency: 782 MHz; Duty Cycle: 1:1
 Medium: MSL750; Medium parameters used (interpolated): $f = 782 \text{ MHz}$; $\sigma = 1 \text{ S/m}$; $\epsilon_r = 55.452$; $\rho = 1000 \text{ kg/m}^3$
 Phantom section: Flat Section

Test Date: Date: 4/10/2019; Ambient Temp: 23 °C; Tissue Temp: 21 °C

Probe: EX3DV4 - SN3693; ConvF(9.64, 9.64, 9.64); Calibrated: 8/27/2018;
 Sensor-Surface: 2mm (Mechanical Surface Detection)
 Electronics: DAE4 Sn1217; Calibrated: 2/15/2019
 Phantom: ELI v4.0; Type: QDOVA001BB; Serial: 1065
 Measurement SW: DASY52, Version 52.10 (0); SEMCAD X Version 14.6.10 (7417)

Procedure Notes:

B13 LTE/Right Mid 1RB 24 Offset/Area Scan (7x9x1): Measurement grid: dx=15mm, dy=15mm

[Info: Interpolated medium parameters used for SAR evaluation.](#)

Maximum value of SAR (measured) = 1.33 W/kg

B13 LTE/Right Mid 1RB 24 Offset/Zoom Scan (5x5x7)/Cube 0: Measurement grid: dx=8mm, dy=8mm, dz=5mm

Reference Value = 18.40 V/m; Power Drift = 0.02 dB

Peak SAR (extrapolated) = 1.81 W/kg

SAR(1 g) = 1.05 W/kg; SAR(10 g) = 0.627 W/kg

[Info: Interpolated medium parameters used for SAR evaluation.](#)

Maximum value of SAR (measured) = 1.43 W/kg

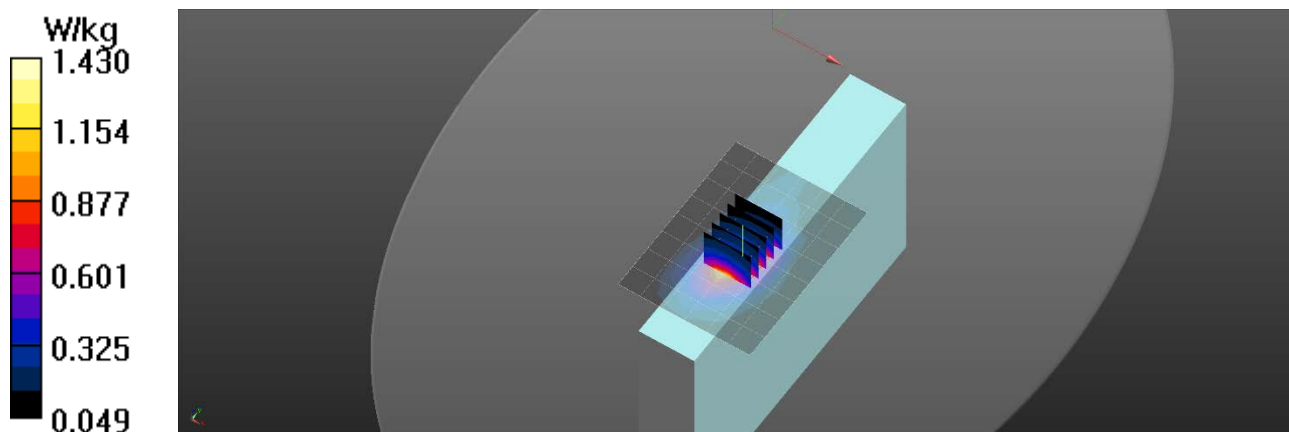

RF Exposure Lab

Plot 3

DUT: MS3; Type: Tablet Computer; Serial: MS3W-C08

Communication System: UMTS (WCDMA); Frequency: 836.6 MHz; Duty Cycle: 1:1
 Medium: MSL835; Medium parameters used (interpolated): $f = 836.6$ MHz; $\sigma = 0.99$ S/m; $\epsilon_r = 55.902$; $\rho = 1000$ kg/m³
 Phantom section: Flat Section

Test Date: Date: 4/8/2019; Ambient Temp: 23 °C; Tissue Temp: 21 °C

Probe: EX3DV4 - SN3693; ConvF(9.4, 9.4, 9.4); Calibrated: 8/27/2018;
 Sensor-Surface: 2mm (Mechanical Surface Detection)
 Electronics: DAE4 Sn1217; Calibrated: 2/15/2019
 Phantom: ELI v4.0; Type: QDOVA001BB; Serial: 1065
 Measurement SW: DASY52, Version 52.10 (0); SEMCAD X Version 14.6.10 (7417)

Procedure Notes:

B5 WCDMA/Back Mid/Area Scan (7x9x1): Measurement grid: dx=15mm, dy=15mm

[Info: Interpolated medium parameters used for SAR evaluation.](#)

Maximum value of SAR (measured) = 0.587 W/kg

B5 WCDMA/Back Mid/Zoom Scan (5x5x7)/Cube 0: Measurement grid: dx=8mm, dy=8mm, dz=5mm

Reference Value = 17.75 V/m; Power Drift = -0.03 dB

Peak SAR (extrapolated) = 2.21 W/kg

SAR(1 g) = 1.25 W/kg; SAR(10 g) = 0.604 W/kg

[Info: Interpolated medium parameters used for SAR evaluation.](#)

Maximum value of SAR (measured) = 1.65 W/kg

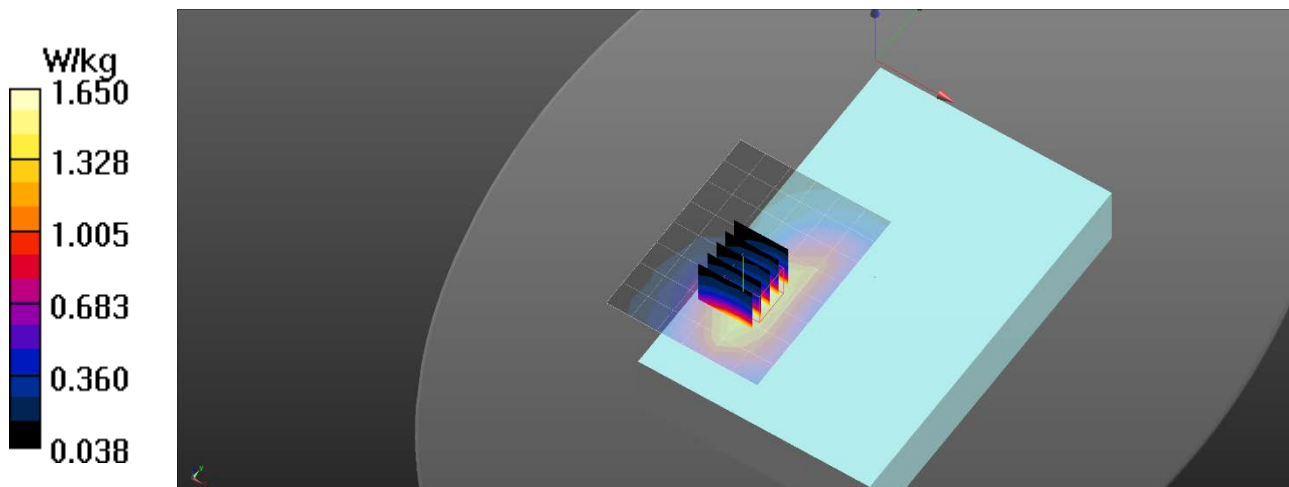

RF Exposure Lab

Plot 4

DUT: MS3; Type: Tablet Computer; Serial: MS3W-C08

Communication System: LTE (SC-FDMA, 1 RB, 10 MHz, QPSK); Frequency: 831.5 MHz; Duty Cycle: 1:1
 Medium: MSL835; Medium parameters used (interpolated): $f = 831.5$ MHz; $\sigma = 0.987$ S/m; $\epsilon_r = 55.924$; $\rho = 1000$ kg/m³
 Phantom section: Flat Section

Test Date: Date: 4/8/2019; Ambient Temp: 23 °C; Tissue Temp: 21 °C

Probe: EX3DV4 - SN3693; ConvF(9.4, 9.4, 9.4); Calibrated: 8/27/2018;
 Sensor-Surface: 2mm (Mechanical Surface Detection)
 Electronics: DAE4 Sn1217; Calibrated: 2/15/2019
 Phantom: ELI v4.0; Type: QDOVA001BB; Serial: 1065
 Measurement SW: DASY52, Version 52.10 (0); SEMCAD X Version 14.6.10 (7417)

Procedure Notes:

B26 LTE/Back Mid 1 RB 24 Offset/Area Scan (7x9x1): Measurement grid: dx=15mm, dy=15mm

[Info: Interpolated medium parameters used for SAR evaluation.](#)

Maximum value of SAR (measured) = 0.150 W/kg

B26 LTE/Back Mid 1 RB 24 Offset/Zoom Scan (5x5x7)/Cube 0: Measurement grid: dx=8mm, dy=8mm, dz=5mm

Reference Value = 18.04 V/m; Power Drift = -0.03 dB

Peak SAR (extrapolated) = 1.66 W/kg

SAR(1 g) = 0.646 W/kg; SAR(10 g) = 0.292 W/kg

[Info: Interpolated medium parameters used for SAR evaluation.](#)

Maximum value of SAR (measured) = 1.31 W/kg

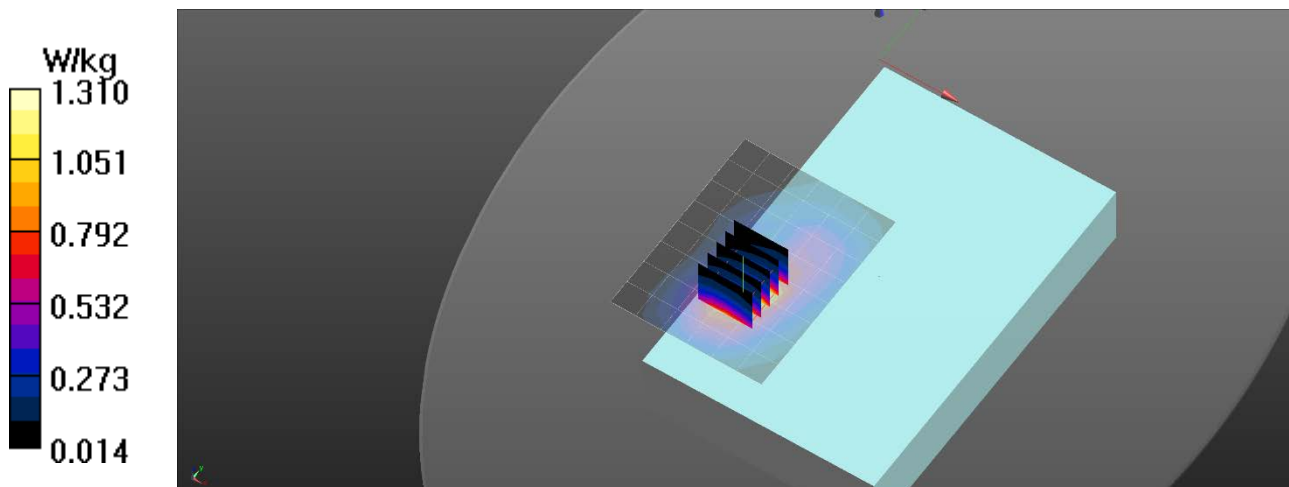

RF Exposure Lab

Plot 5

DUT: MS3; Type: Tablet Computer; Serial: MS3W-C08

Communication System: UMTS (WCDMA); Frequency: 1752.6 MHz; Duty Cycle: 1:1
 Medium: MSL1750; Medium parameters used (interpolated): $f = 1752.6$ MHz; $\sigma = 1.523$ S/m; $\epsilon_r = 53.315$; $\rho = 1000$ kg/m³
 Phantom section: Flat Section

Test Date: Date: 4/9/2019; Ambient Temp: 23 °C; Tissue Temp: 21 °C

Probe: EX3DV4 - SN3693; ConvF(7.77, 7.77, 7.77); Calibrated: 8/27/2018;
 Sensor-Surface: 2mm (Mechanical Surface Detection)
 Electronics: DAE4 Sn1217; Calibrated: 2/15/2019
 Phantom: ELI v4.0; Type: QDOVA001BB; Serial: 1065
 Measurement SW: DASY52, Version 52.10 (0); SEMCAD X Version 14.6.10 (7417)

Procedure Notes:

B4 WCDMA/Right High/Area Scan (7x9x1): Measurement grid: dx=15mm, dy=15mm

Info: [Interpolated medium parameters used for SAR evaluation.](#)
 Maximum value of SAR (measured) = 1.25 W/kg

B4 WCDMA/Right High/Zoom Scan (5x5x7)/Cube 0: Measurement grid: dx=8mm, dy=8mm, dz=5mm
 Reference Value = 26.37 V/m; Power Drift = 0.02 dB
 Peak SAR (extrapolated) = 2.61 W/kg
SAR(1 g) = 1.33 W/kg; SAR(10 g) = 0.646 W/kg

Info: [Interpolated medium parameters used for SAR evaluation.](#)
 Maximum value of SAR (measured) = 1.89 W/kg

B4 WCDMA/Right High/Zoom Scan (5x5x7)/Cube 1: Measurement grid: dx=8mm, dy=8mm, dz=5mm
 Reference Value = 26.37 V/m; Power Drift = 0.02 dB
 Peak SAR (extrapolated) = 1.40 W/kg
SAR(1 g) = 0.873 W/kg; SAR(10 g) = 0.503 W/kg

Info: [Interpolated medium parameters used for SAR evaluation.](#)
 Maximum value of SAR (measured) = 1.16 W/kg

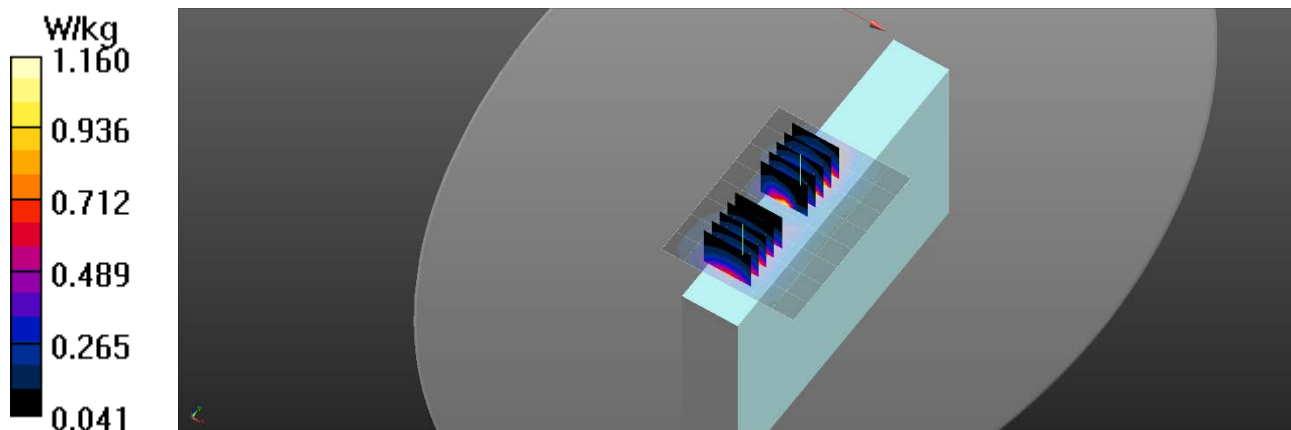

RF Exposure Lab

Plot 6

DUT: MS3; Type: Tablet Computer; Serial: MS3W-C08

Communication System: LTE (SC-FDMA, 1 RB, 20 MHz, QPSK); Frequency: 1720 MHz; Duty Cycle: 1:1
Medium: MSL1750; Medium parameters used: $f = 1720$ MHz; $\sigma = 1.49$ S/m; $\epsilon_r = 53.52$; $\rho = 1000$ kg/m³
Phantom section: Flat Section

Test Date: Date: 4/9/2019; Ambient Temp: 23 °C; Tissue Temp: 21 °C

Probe: EX3DV4 - SN3693; ConvF(7.77, 7.77, 7.77); Calibrated: 8/27/2018;
Sensor-Surface: 2mm (Mechanical Surface Detection)
Electronics: DAE4 Sn1217; Calibrated: 2/15/2019
Phantom: ELI v4.0; Type: QDOVA001BB; Serial: 1065
Measurement SW: DASY52, Version 52.10 (0); SEMCAD X Version 14.6.10 (7417)

Procedure Notes:

B4 LTE/Right Low 1 RB 49 Offset/Area Scan (7x9x1): Measurement grid: dx=15mm, dy=15mm
Maximum value of SAR (measured) = 1.92 W/kg

B4 LTE/Right Low 1 RB 49 Offset/Zoom Scan (5x5x7)/Cube 0: Measurement grid: dx=8mm, dy=8mm, dz=5mm
Reference Value = 25.60 V/m; Power Drift = -0.03 dB
Peak SAR (extrapolated) = 2.38 W/kg
SAR(1 g) = 1.25 W/kg; SAR(10 g) = 0.611 W/kg
Maximum value of SAR (measured) = 1.86 W/kg

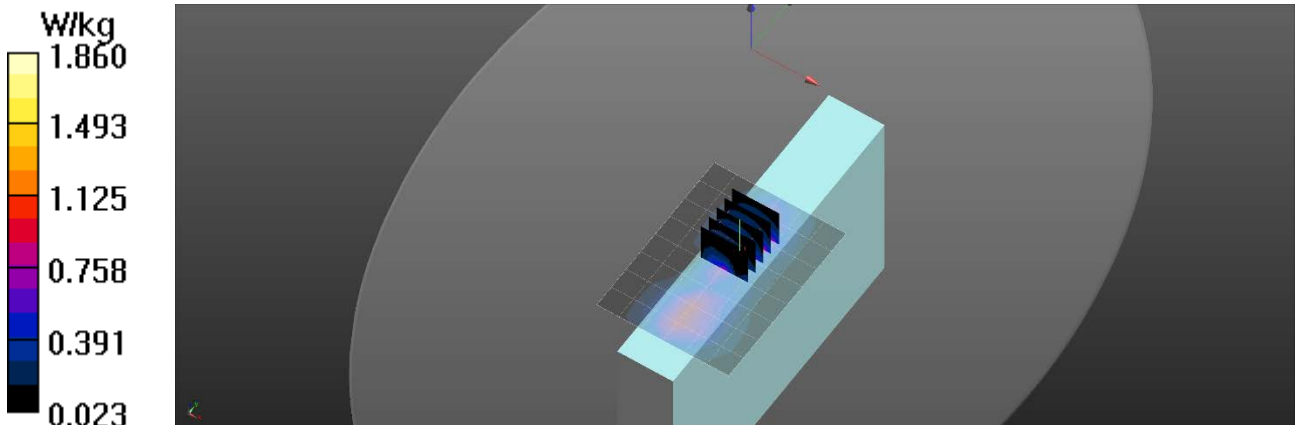

RF Exposure Lab

Plot 7

DUT: MS3; Type: Tablet Computer; Serial: MS3W-C08

Communication System: UMTS (WCDMA); Frequency: 1907.6 MHz; Duty Cycle: 1:1
Medium: MSL1900; Medium parameters used (interpolated): $f = 1907.6$ MHz; $\sigma = 1.493$ S/m; $\epsilon_r = 52.108$; $\rho = 1000$ kg/m³
Phantom section: Flat Section

Test Date: Date: 4/10/2019; Ambient Temp: 23 °C; Tissue Temp: 21 °C

Probe: EX3DV4 - SN3693; ConvF(7.44, 7.44, 7.44); Calibrated: 8/27/2018;
Sensor-Surface: 2mm (Mechanical Surface Detection)
Electronics: DAE4 Sn1217; Calibrated: 2/15/2019
Phantom: ELI v4.0; Type: QDOVA001BB; Serial: 1065
Measurement SW: DASY52, Version 52.10 (0); SEMCAD X Version 14.6.10 (7417)

Procedure Notes:

B2 WCDMA/Right High/Area Scan (7x9x1): Measurement grid: dx=15mm, dy=15mm

[Info: Interpolated medium parameters used for SAR evaluation.](#)

Maximum value of SAR (measured) = 1.99 W/kg

B2 WCDMA/Right High/Zoom Scan (5x5x7)/Cube 0: Measurement grid: dx=8mm, dy=8mm, dz=5mm

Reference Value = 24.33 V/m; Power Drift = 0.02 dB

Peak SAR (extrapolated) = 2.55 W/kg

SAR(1 g) = 1.31 W/kg; SAR(10 g) = 0.628 W/kg

[Info: Interpolated medium parameters used for SAR evaluation.](#)

Maximum value of SAR (measured) = 1.96 W/kg

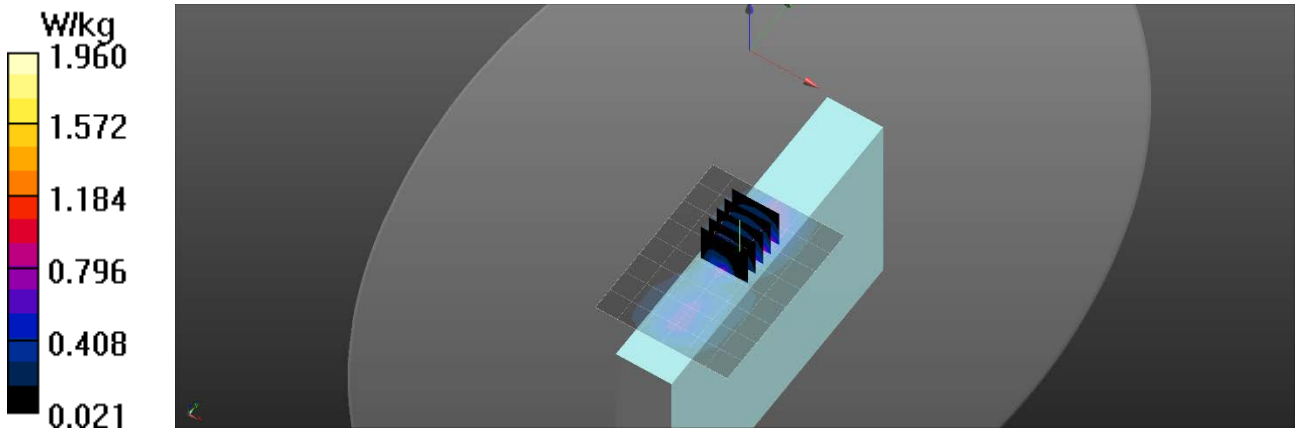

RF Exposure Lab

Plot 8

DUT: MS3; Type: Tablet Computer; Serial: MS3W-C08

Communication System: LTE (SC-FDMA, 1 RB, 20 MHz, QPSK); Frequency: 1905 MHz; Duty Cycle: 1:1
 Medium: MSL1900; Medium parameters used (interpolated): $f = 1905$ MHz; $\sigma = 1.493$ S/m; $\epsilon_r = 52.108$; $\rho = 1000$ kg/m³
 Phantom section: Flat Section

Test Date: Date: 4/10/2019; Ambient Temp: 23 °C; Tissue Temp: 21 °C

Probe: EX3DV4 - SN3693; ConvF(7.44, 7.44, 7.44); Calibrated: 8/27/2018;
 Sensor-Surface: 2mm (Mechanical Surface Detection)
 Electronics: DAE4 Sn1217; Calibrated: 2/15/2019
 Phantom: ELI v4.0; Type: QDOVA001BB; Serial: 1065
 Measurement SW: DASY52, Version 52.10 (0); SEMCAD X Version 14.6.10 (7417)

Procedure Notes:

B25 LTE/Right High 1 RB 49 Offset/Area Scan (7x9x1): Measurement grid: dx=15mm, dy=15mm

[Info: Interpolated medium parameters used for SAR evaluation.](#)

Maximum value of SAR (measured) = 1.82 W/kg

B25 LTE/Right High 1 RB 49 Offset/Zoom Scan (5x5x7)/Cube 0: Measurement grid: dx=8mm, dy=8mm, dz=5mm

Reference Value = 24.58 V/m; Power Drift = 0.04 dB

Peak SAR (extrapolated) = 2.38 W/kg

SAR(1 g) = 1.2 W/kg; SAR(10 g) = 0.569 W/kg

[Info: Interpolated medium parameters used for SAR evaluation.](#)

Maximum value of SAR (measured) = 1.80 W/kg

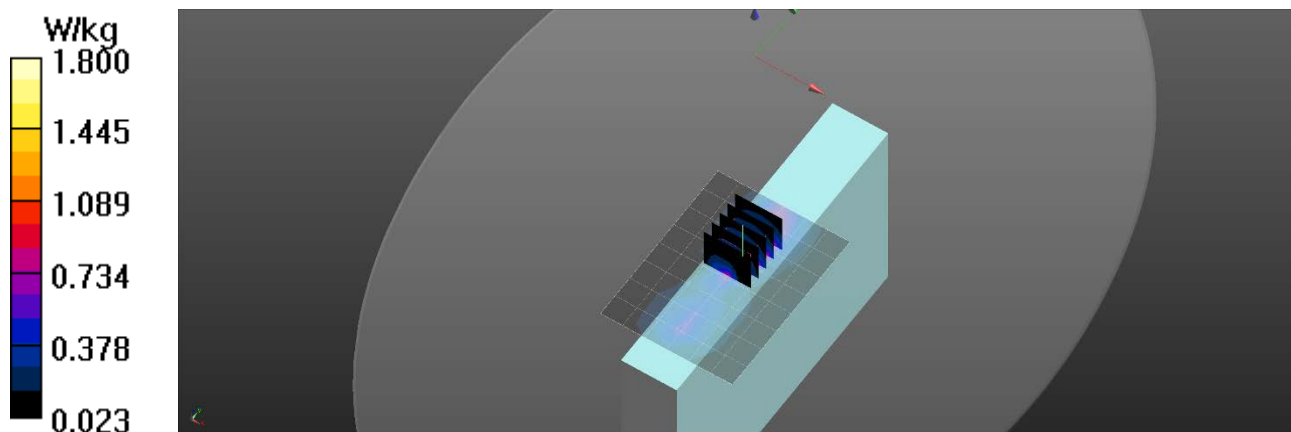

RF Exposure Lab

Plot 9

DUT: MS3; Type: Tablet Computer; Serial: MS3W-C08

Communication System: LTE (SC-FDMA, 1 RB, 20 MHz, QPSK); Frequency: 2535 MHz; Duty Cycle: 1:1
 Medium: MSL2550; Medium parameters used (interpolated): $f = 2535 \text{ MHz}$; $\sigma = 2.09 \text{ S/m}$; $\epsilon_r = 52.205$; $\rho = 1000 \text{ kg/m}^3$
 Phantom section: Flat Section

Test Date: Date: 4/5/2019; Ambient Temp: 23 °C; Tissue Temp: 21 °C

Probe: EX3DV4 - SN3693; ConvF(7.13, 7.13, 7.13); Calibrated: 8/27/2018;
 Sensor-Surface: 2mm (Mechanical Surface Detection)
 Electronics: DAE4 Sn1217; Calibrated: 2/15/2019
 Phantom: ELI v4.0; Type: QDOVA001BB; Serial: 1065
 Measurement SW: DASY52, Version 52.10 (0); SEMCAD X Version 14.6.10 (7417)

Procedure Notes:

B7 LTE/Right 1 RB 49 Offset Mid/Area Scan (7x9x1): Measurement grid: dx=15mm, dy=15mm

[Info: Interpolated medium parameters used for SAR evaluation.](#)

Maximum value of SAR (measured) = 1.79 W/kg

B7 LTE/Right 1 RB 49 Offset Mid/Zoom Scan (5x5x7)/Cube 0: Measurement grid: dx=8mm, dy=8mm, dz=5mm

Reference Value = 16.40 V/m; Power Drift = 0.03 dB

Peak SAR (extrapolated) = 2.51 W/kg

SAR(1 g) = 1.21 W/kg; SAR(10 g) = 0.588 W/kg

[Info: Interpolated medium parameters used for SAR evaluation.](#)

Maximum value of SAR (measured) = 1.85 W/kg

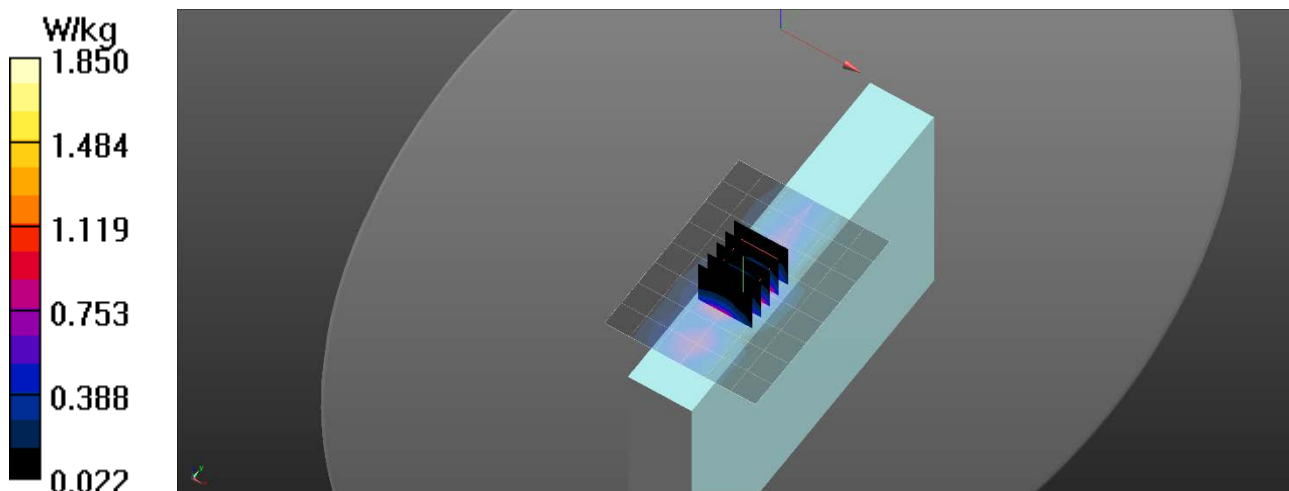

RF Exposure Lab

Plot 10

DUT: MS3; Type: Tablet Computer; Serial: MS3W-C08

Communication System: LTE (SC-FDMA, 1 RB, 20 MHz, QPSK); Frequency: 2593 MHz; Duty Cycle: 1:1
Medium: MSL2550; Medium parameters used (interpolated): $f = 2593$ MHz; $\sigma = 2.186$ S/m; $\epsilon_r = 52.097$; $\rho = 1000$ kg/m³
Phantom section: Flat Section

Test Date: Date: 4/5/2019; Ambient Temp: 23 °C; Tissue Temp: 21 °C

Probe: EX3DV4 - SN3693; ConvF(7.13, 7.13, 7.13); Calibrated: 8/27/2018;
Sensor-Surface: 2mm (Mechanical Surface Detection)
Electronics: DAE4 Sn1217; Calibrated: 2/15/2019
Phantom: ELI v4.0; Type: QDOVA001BB; Serial: 1065
Measurement SW: DASY52, Version 52.10 (0); SEMCAD X Version 14.6.10 (7417)

Procedure Notes:

B41 LTE/Right 1 RB 49 Offset Mid/Area Scan (7x9x1): Measurement grid: dx=15mm, dy=15mm

[Info: Interpolated medium parameters used for SAR evaluation.](#)

Maximum value of SAR (measured) = 0.839 W/kg

B41 LTE/Right 1 RB 49 Offset Mid/Zoom Scan (5x5x7)/Cube 0: Measurement grid: dx=8mm, dy=8mm, dz=5mm

Reference Value = 12.00 V/m; Power Drift = 0.01 dB

Peak SAR (extrapolated) = 1.22 W/kg

SAR(1 g) = 0.571 W/kg; SAR(10 g) = 0.270 W/kg

[Info: Interpolated medium parameters used for SAR evaluation.](#)

Maximum value of SAR (measured) = 0.883 W/kg

B41 LTE/Right 1 RB 49 Offset Mid/Zoom Scan (5x5x7)/Cube 1: Measurement grid: dx=8mm, dy=8mm, dz=5mm

Reference Value = 12.00 V/m; Power Drift = 0.01 dB

Peak SAR (extrapolated) = 0.901 W/kg

SAR(1 g) = 0.460 W/kg; SAR(10 g) = 0.239 W/kg

[Info: Interpolated medium parameters used for SAR evaluation.](#)

Maximum value of SAR (measured) = 0.664 W/kg

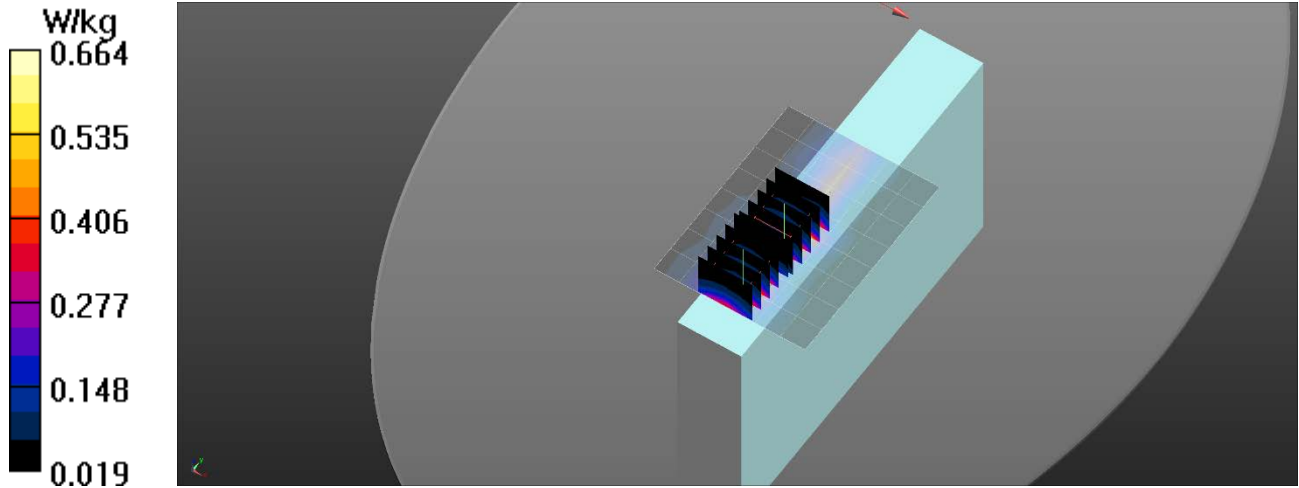

RF Exposure Lab

Plot 11

DUT: MS3; Type: Tablet Computer; Serial: MS3W-C08

Communication System: FM; Frequency: 920 MHz; Duty Cycle: 1:1.99986
Medium: MSL900; Medium parameters used: $f = 920 \text{ MHz}$; $\sigma = 1.08 \text{ S/m}$; $\epsilon_r = 55.33$; $\rho = 1000 \text{ kg/m}^3$
Phantom section: Flat Section

Test Date: Date: 4/9/2019; Ambient Temp: 23 °C; Tissue Temp: 21 °C

Probe: EX3DV4 - SN3693; ConvF(9.25, 9.25, 9.25); Calibrated: 8/27/2018;
Sensor-Surface: 2mm (Mechanical Surface Detection)
Electronics: DAE4 Sn1217; Calibrated: 2/15/2019
Phantom: ELI v4.0; Type: QDOVA001BB; Serial: 1065
Measurement SW: DASY52, Version 52.10 (0); SEMCAD X Version 14.6.10 (7417)

Procedure Notes:

900 MHz Micro RFID/Back Mid/Area Scan (7x7x1): Measurement grid: dx=15mm, dy=15mm
Maximum value of SAR (measured) = 2.70 W/kg

900 MHz Micro RFID/Back Mid/Zoom Scan (5x5x7)/Cube 0: Measurement grid: dx=8mm, dy=8mm, dz=5mm
Reference Value = 13.74 V/m; Power Drift = -0.03 dB
Peak SAR (extrapolated) = 4.11 W/kg
SAR(1 g) = 2.04 W/kg; SAR(10 g) = 0.929 W/kg
Maximum value of SAR (measured) = 3.74 W/kg

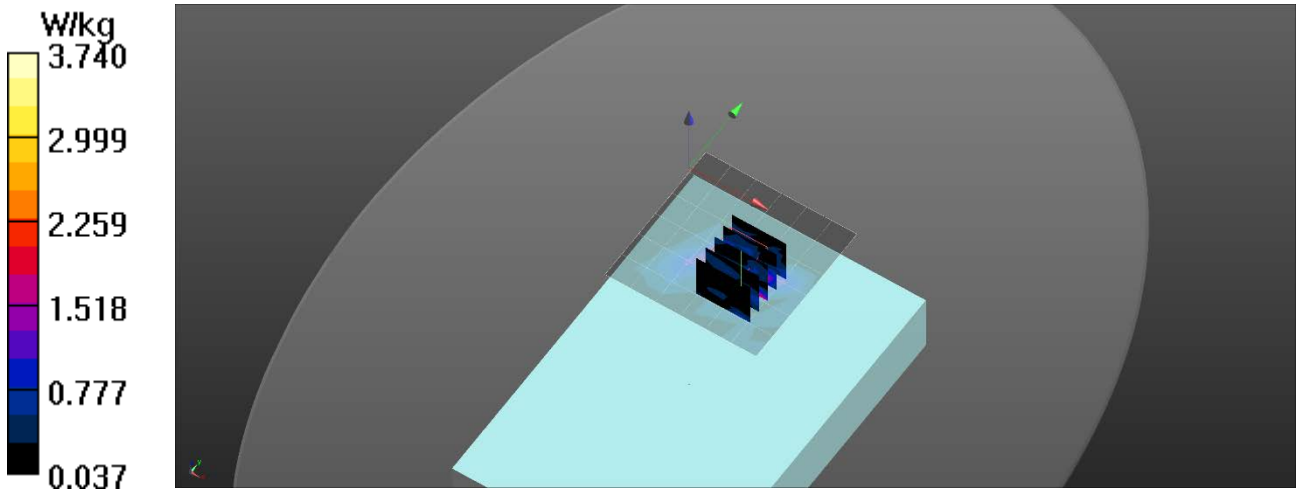

RF Exposure Lab

Plot 12

DUT: MS3; Type: Tablet Computer; Serial: MS3W-C07, MS3W-C08, MS3W-C16

Communication System: FM; Frequency: 922.3 MHz; Duty Cycle: 1:1.99986
 Medium: MSL900; Medium parameters used (interpolated): $f = 922.3 \text{ MHz}$; $\sigma = 1.082 \text{ S/m}$; $\epsilon_r = 55.323$; $\rho = 1000 \text{ kg/m}^3$
 Phantom section: Flat Section

Test Date: Date: 4/9/2019; Ambient Temp: 23 °C; Tissue Temp: 21 °C

Probe: EX3DV4 - SN3693; ConvF(9.25, 9.25, 9.25); Calibrated: 8/27/2018;
 Sensor-Surface: 2mm (Mechanical Surface Detection)
 Electronics: DAE4 Sn1217; Calibrated: 2/15/2019
 Phantom: ELI v4.0; Type: QDOVA001BB; Serial: 1065
 Measurement SW: DASY52, Version 52.10 (0); SEMCAD X Version 14.6.10 (7417)

Procedure Notes:

900 MHz Nano RFID/Back Mid/Area Scan (7x7x1): Measurement grid: dx=15mm, dy=15mm

[Info: Interpolated medium parameters used for SAR evaluation.](#)

Maximum value of SAR (measured) = 3.40 W/kg

900 MHz Nano RFID/Back Mid/Zoom Scan (5x5x7)/Cube 0: Measurement grid: dx=8mm, dy=8mm, dz=5mm

Reference Value = 9.478 V/m; Power Drift = 0.04 dB

Peak SAR (extrapolated) = 8.33 W/kg

SAR(1 g) = 1.89 W/kg; SAR(10 g) = 0.583 W/kg

[Info: Interpolated medium parameters used for SAR evaluation.](#)

Maximum value of SAR (measured) = 3.12 W/kg

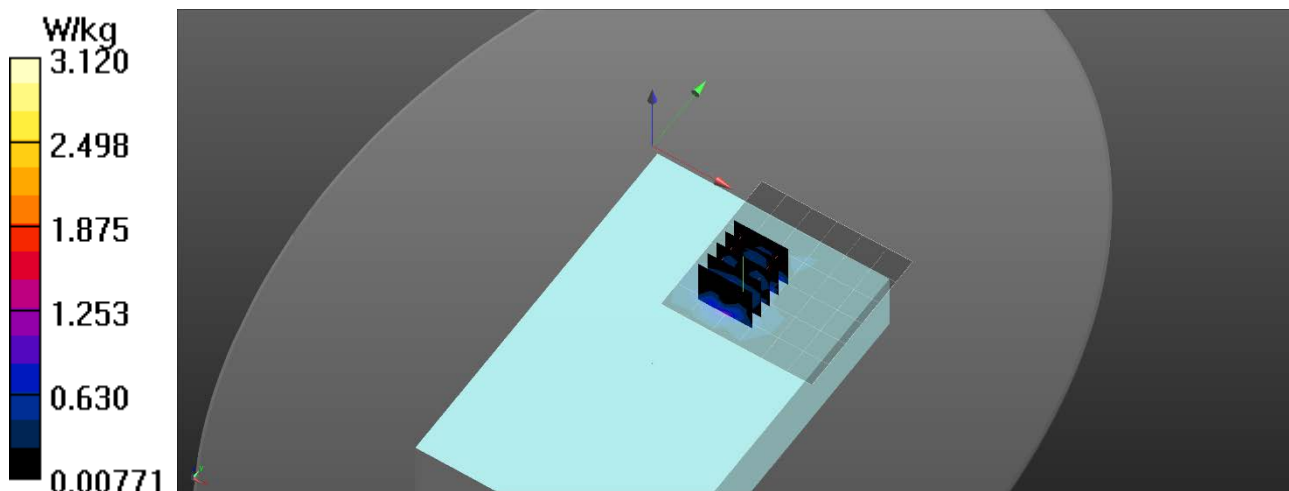

RF Exposure Lab

Plot 13

DUT: MS3; Type: Tablet Computer; Serial: MS3W-C08

Communication System: WiFi 802.11b (DSSS, 1 Mbps); Frequency: 2437 MHz; Duty Cycle: 1:1
 Medium: MSL2450; Medium parameters used (interpolated): $f = 2437$ MHz; $\sigma = 1.907$ S/m; $\epsilon_r = 52.796$; $\rho = 1000$ kg/m³
 Phantom section: Flat Section

Test Date: Date: 4/6/2019; Ambient Temp: 23 °C; Tissue Temp: 21 °C

Probe: EX3DV4 - SN3693; ConvF(7.29, 7.29, 7.29); Calibrated: 8/27/2018;
 Sensor-Surface: 2mm (Mechanical Surface Detection)
 Electronics: DAE4 Sn1217; Calibrated: 2/15/2019
 Phantom: ELI v4.0; Type: QDOVA001BB; Serial: 1065
 Measurement SW: DASY52, Version 52.10 (0); SEMCAD X Version 14.6.10 (7417)

Procedure Notes:

2.4 GHz/Primary Left 6/Area Scan (7x9x1): Measurement grid: dx=10mm, dy=10mm

[Info: Interpolated medium parameters used for SAR evaluation.](#)
 Maximum value of SAR (measured) = 0.471 W/kg

2.4 GHz/Primary Left 6/Zoom Scan (7x7x7)/Cube 0: Measurement grid: dx=5mm, dy=5mm, dz=5mm

Reference Value = 11.12 V/m; Power Drift = -0.01 dB
 Peak SAR (extrapolated) = 0.641 W/kg
SAR(1 g) = 0.336 W/kg; SAR(10 g) = 0.180 W/kg

[Info: Interpolated medium parameters used for SAR evaluation.](#)
 Maximum value of SAR (measured) = 0.485 W/kg

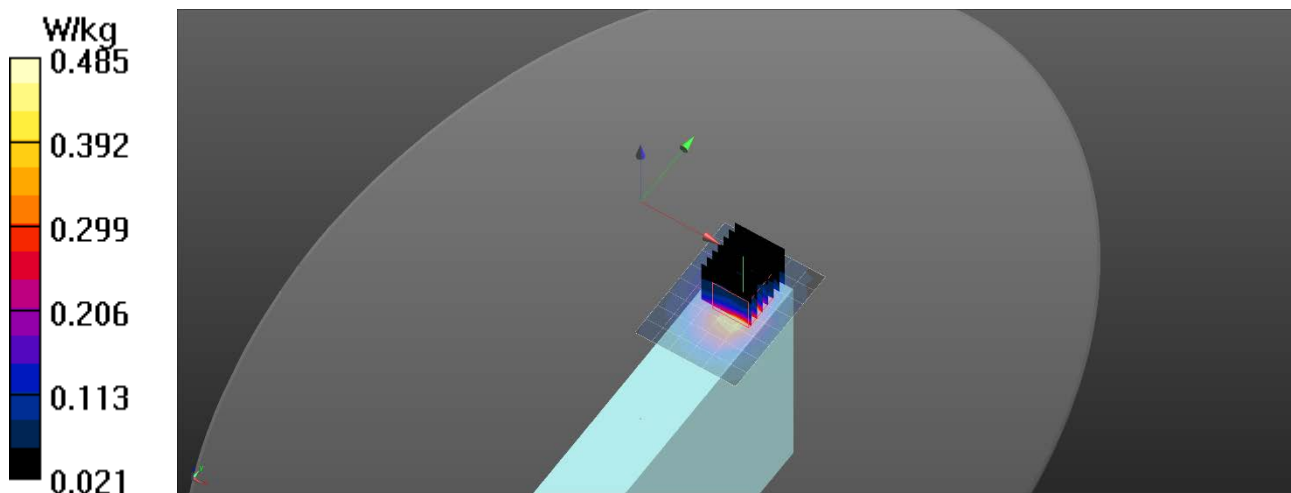

RF Exposure Lab

Plot 14

DUT: MS3; Type: Tablet Computer; Serial: MS3W-C08

Communication System: WiFi 802.11a (OFDM, 6 Mbps); Frequency: 5300 MHz; Duty Cycle: 1:1
 Medium: MSL 3-6 GHz; Medium parameters used: $f = 5300$ MHz; $\sigma = 5.33$ S/m; $\epsilon_r = 48.92$; $\rho = 1000$ kg/m³
 Phantom section: Flat Section

Test Date: Date: 4/10/2019; Ambient Temp: 23 °C; Tissue Temp: 21 °C

Probe: EX3DV4 - SN3693; ConvF(4.46, 4.46, 4.46); Calibrated: 8/27/2018;
 Sensor-Surface: 2mm (Mechanical Surface Detection)
 Electronics: DAE4 Sn1217; Calibrated: 2/15/2019
 Phantom: ELI v4.0; Type: QDOVA001BB; Serial: 1065
 Measurement SW: DASY52, Version 52.10 (0); SEMCAD X Version 14.6.10 (7417)

Procedure Notes:

5.2 GHz/Primary Back 60/Area Scan (9x7x1): Measurement grid: dx=10mm, dy=10mm
 Maximum value of SAR (measured) = 1.75 W/kg

5.2 GHz/Primary Back 60/Zoom Scan (7x7x12)/Cube 0: Measurement grid: dx=4mm, dy=4mm, dz=2mm
 Reference Value = 4.625 V/m; Power Drift = -0.02 dB
 Peak SAR (extrapolated) = 4.95 W/kg
SAR(1 g) = 1.23 W/kg; SAR(10 g) = 0.437 W/kg
 Maximum value of SAR (measured) = 2.44 W/kg

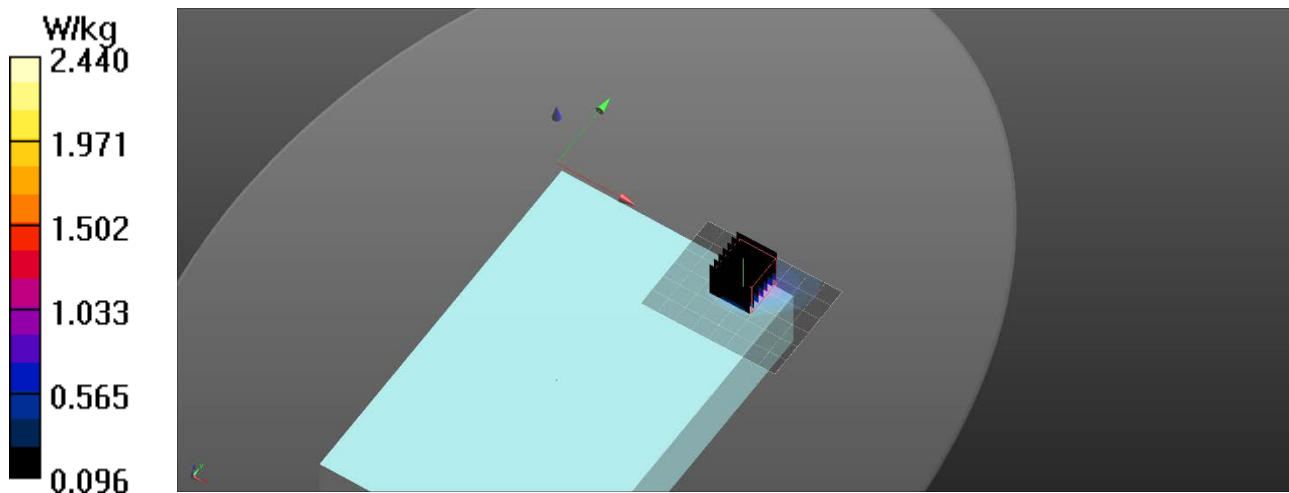

RF Exposure Lab

Plot 15

DUT: MS3; Type: Tablet Computer; Serial: MS3W-C08

Communication System: WiFi 802.11a (OFDM, 6 Mbps); Frequency: 5620 MHz; Duty Cycle: 1:1
 Medium: MSL 3-6 GHz; Medium parameters used: $f = 5620$ MHz; $\sigma = 5.75$ S/m; $\epsilon_r = 48.44$; $\rho = 1000$ kg/m³
 Phantom section: Flat Section

Test Date: Date: 4/11/2019; Ambient Temp: 23 °C; Tissue Temp: 21 °C

Probe: EX3DV4 - SN3693; ConvF(3.91, 3.91, 3.91); Calibrated: 8/27/2018;
 Sensor-Surface: 2mm (Mechanical Surface Detection)
 Electronics: DAE4 Sn1217; Calibrated: 2/15/2019
 Phantom: ELI v4.0; Type: QDOVA001BB; Serial: 1065
 Measurement SW: DASY52, Version 52.10 (0); SEMCAD X Version 14.6.10 (7417)

Procedure Notes:

5.6 GHz/Primary Left 124/Area Scan (7x9x1): Measurement grid: dx=10mm, dy=10mm
 Maximum value of SAR (measured) = 1.96 W/kg

5.6 GHz/Primary Left 124/Zoom Scan (7x7x12)/Cube 0: Measurement grid: dx=4mm, dy=4mm, dz=2mm
 Reference Value = 6.063 V/m; Power Drift = 0.02 dB
 Peak SAR (extrapolated) = 5.69 W/kg
SAR(1 g) = 1.25 W/kg; SAR(10 g) = 0.475 W/kg
 Maximum value of SAR (measured) = 2.35 W/kg

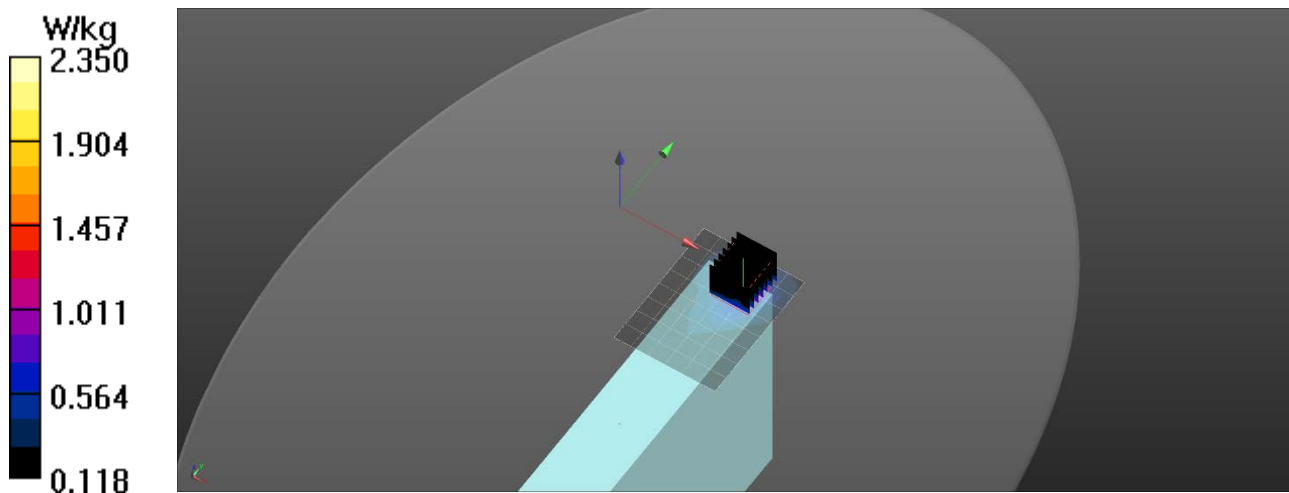

RF Exposure Lab

Plot 16

DUT: MS3; Type: Tablet Computer; Serial: MS3W-C08

Communication System: WiFi 802.11a (OFDM, 6 Mbps); Frequency: 5785 MHz; Duty Cycle: 1:1
Medium: MSL 3-6 GHz; Medium parameters used (interpolated): $f = 5785$ MHz; $\sigma = 5.975$ S/m; $\epsilon_r = 48.193$; $\rho = 1000$ kg/m³
Phantom section: Flat Section

Test Date: Date: 4/10/2019; Ambient Temp: 23 °C; Tissue Temp: 21 °C

Probe: EX3DV4 - SN3693; ConvF(4.05, 4.05, 4.05); Calibrated: 8/27/2018;
Sensor-Surface: 2mm (Mechanical Surface Detection)
Electronics: DAE4 Sn1217; Calibrated: 2/15/2019
Phantom: ELI v4.0; Type: QDOVA001BB; Serial: 1065
Measurement SW: DASY52, Version 52.10 (0); SEMCAD X Version 14.6.10 (7417)

Procedure Notes:

5.8 GHz/Primary Back 157/Area Scan (9x7x1): Measurement grid: dx=10mm, dy=10mm

[Info: Interpolated medium parameters used for SAR evaluation.](#)

Maximum value of SAR (measured) = 2.07 W/kg

5.8 GHz/Primary Back 157/Zoom Scan (7x7x12)/Cube 0: Measurement grid: dx=4mm, dy=4mm, dz=2mm

Reference Value = 5.121 V/m; Power Drift = 0.02 dB

Peak SAR (extrapolated) = 7.69 W/kg

SAR(1 g) = 1.29 W/kg; SAR(10 g) = 0.554 W/kg

[Info: Interpolated medium parameters used for SAR evaluation.](#)

Maximum value of SAR (measured) = 3.20 W/kg

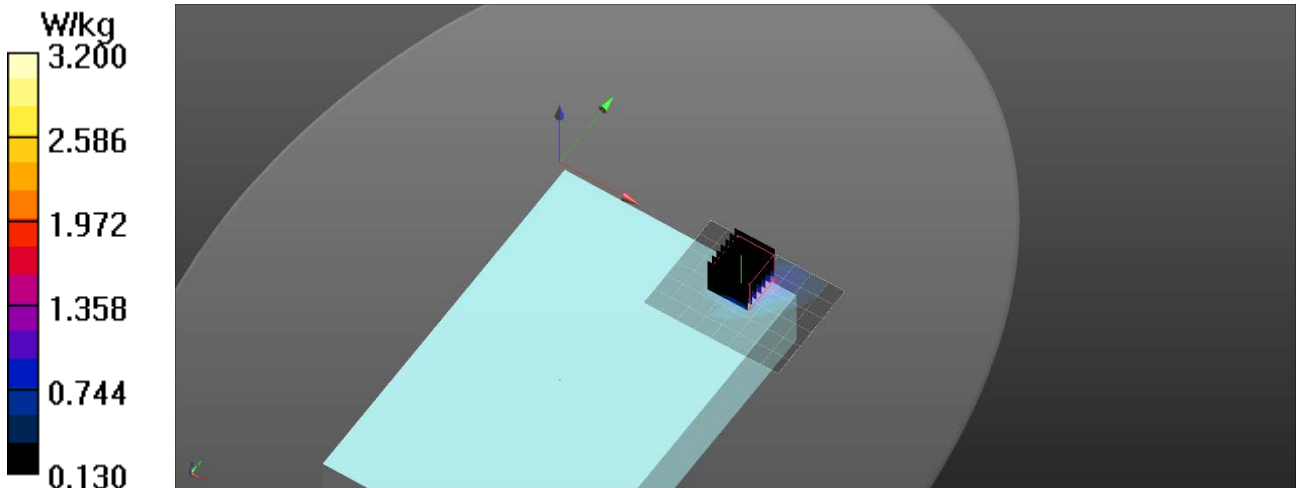

Appendix C – SAR Test Setup Photos



Test Position Back 0 mm Gap

Note: All cables are removed for testing.



Test Position Back WiFi 0 mm Gap

Note: All cables are removed for testing.



Test Position Left 0 mm Gap

Note: All cables are removed for testing.



Test Position Right 0 mm Gap

Note: All cables are removed for testing.



Test Position Top 0 mm Gap

Note: All cables are removed for testing.



Test Position Back RFID 0 mm Gap

Note: All cables are removed for testing.

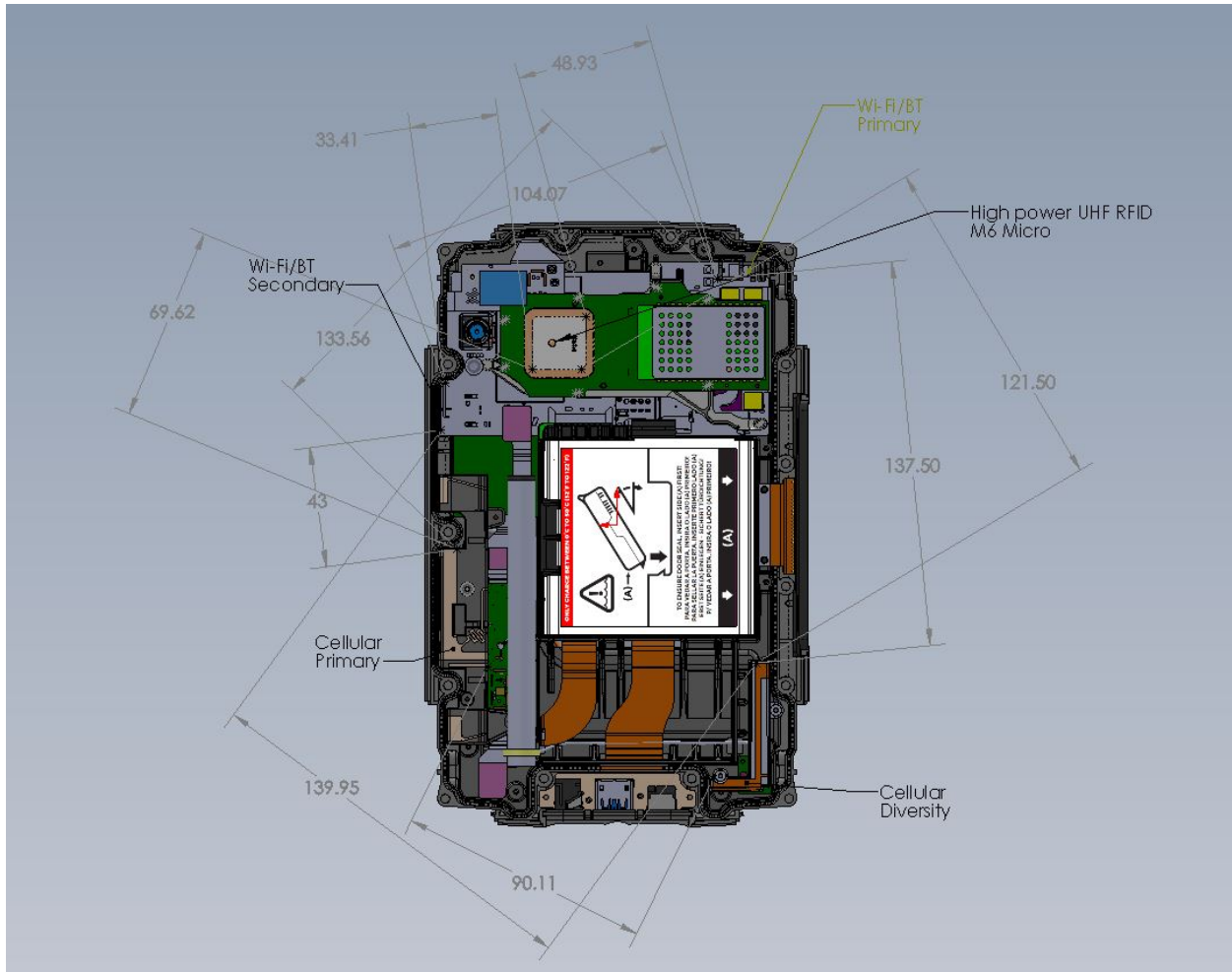

Antenna Locations with Micro RFID

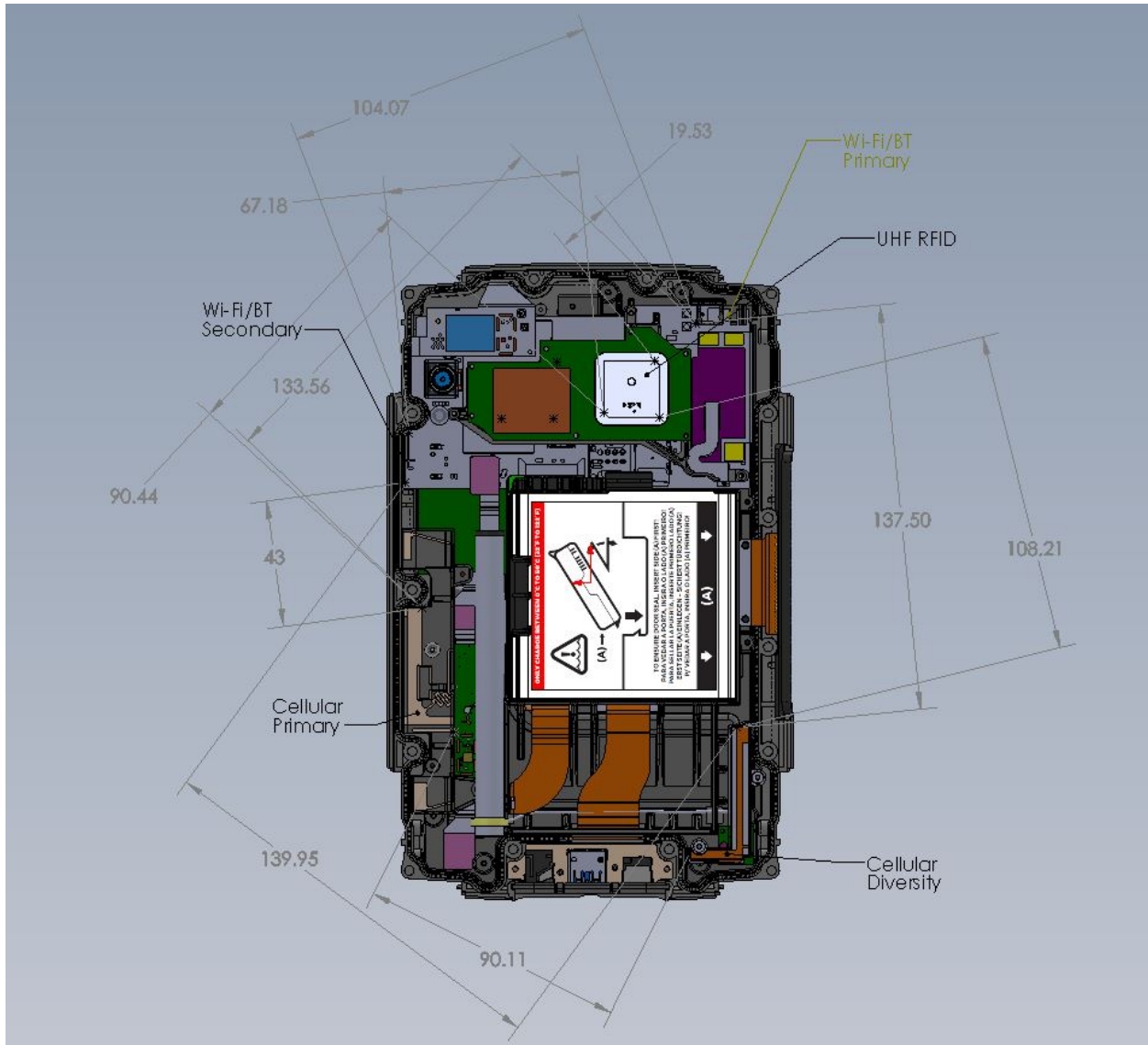

Antenna Locations with Nano RFID

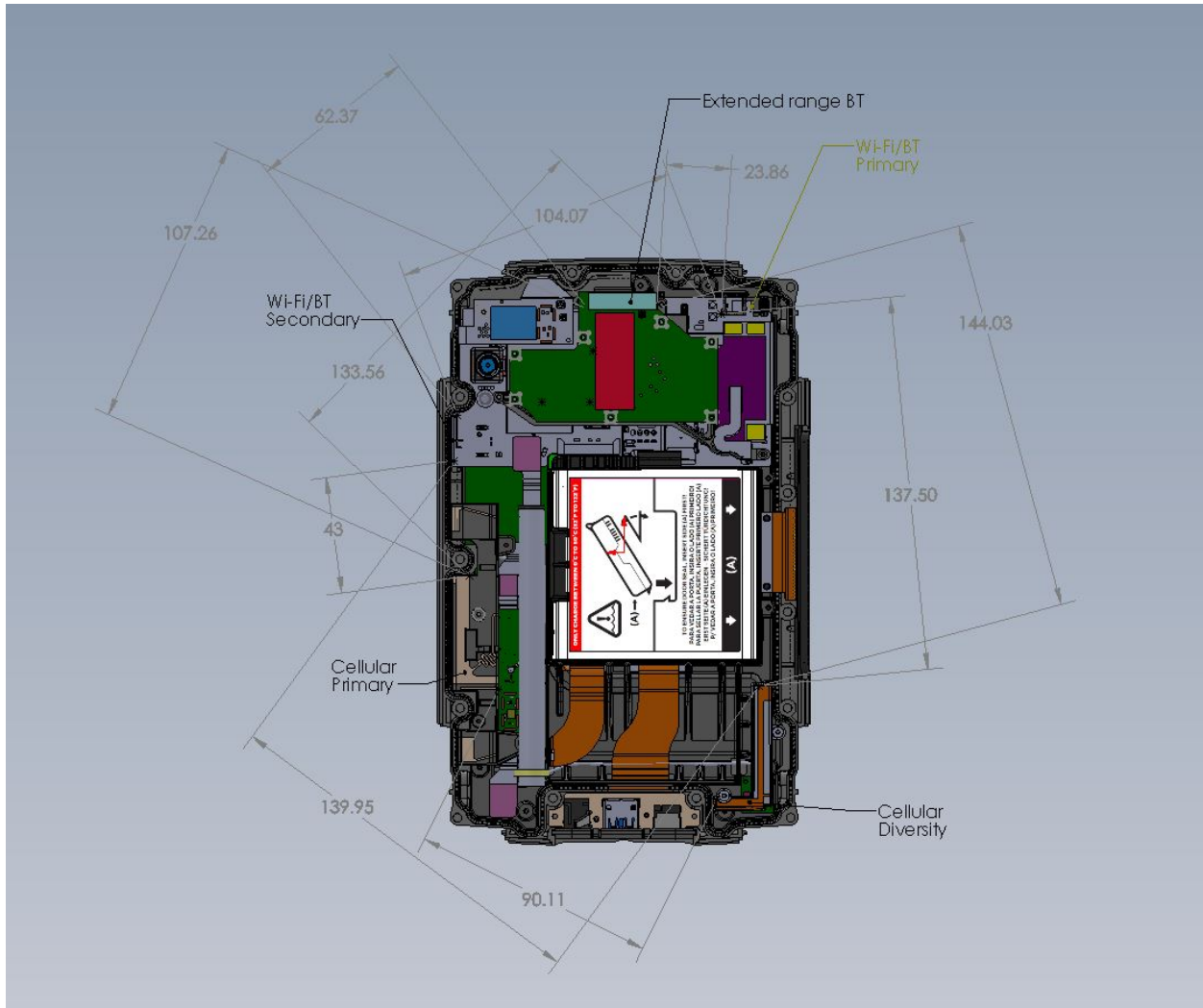

Antenna Locations with BT Extended Range



Front of Device



Back of Device

Appendix D – Probe Calibration Data Sheets



Accredited by the Swiss Accreditation Service (SAS)
The Swiss Accreditation Service is one of the signatories to the EA
Multilateral Agreement for the recognition of calibration certificates

Accreditation No.: **SCS 0108**

Client **RF Exposure Lab**

Certificate No: **EX3-3693_Aug18**

CALIBRATION CERTIFICATE

Object **EX3DV4 - SN:3693**

Calibration procedure(s) **QA CAL-01.v9, QA CAL-14.v4, QA CAL-23.v5, QA CAL-25.v6
Calibration procedure for dosimetric E-field probes**

Calibration date: **August 27, 2018**

This calibration certificate documents the traceability to national standards, which realize the physical units of measurements (SI).
The measurements and the uncertainties with confidence probability are given on the following pages and are part of the certificate.

All calibrations have been conducted in the closed laboratory facility: environment temperature (22 ± 3)°C and humidity < 70%.

Calibration Equipment used (M&TE critical for calibration)

Primary Standards	ID	Cal Date (Certificate No.)	Scheduled Calibration
Power meter NRP	SN: 104778	04-Apr-18 (No. 217-02672/02673)	Apr-19
Power sensor NRP-Z91	SN: 103244	04-Apr-18 (No. 217-02672)	Apr-19
Power sensor NRP-Z91	SN: 103245	04-Apr-18 (No. 217-02673)	Apr-19
Reference 20 dB Attenuator	SN: S5277 (20x)	04-Apr-18 (No. 217-02682)	Apr-19
Reference Probe ES3DV2	SN: 3013	30-Dec-17 (No. ES3-3013_Dec17)	Dec-18
DAE4	SN: 660	21-Dec-17 (No. DAE4-660_Dec17)	Dec-18
Secondary Standards	ID	Check Date (in house)	Scheduled Check
Power meter E4419B	SN: GB41293874	06-Apr-16 (in house check Jun-18)	In house check: Jun-20
Power sensor E4412A	SN: MY41498087	06-Apr-16 (in house check Jun-18)	In house check: Jun-20
Power sensor E4412A	SN: 000110210	06-Apr-16 (in house check Jun-18)	In house check: Jun-20
RF generator HP 8648C	SN: US3642U01700	04-Aug-99 (in house check Jun-18)	In house check: Jun-20
Network Analyzer E8358A	SN: US41080477	31-Mar-14 (in house check Oct-17)	In house check: Oct-18

Calibrated by:	Name Jeton Kastrati	Function Laboratory Technician	Signature
Approved by:	Name Katja Pokovic	Function Technical Manager	

Issued: August 30, 2018

This calibration certificate shall not be reproduced except in full without written approval of the laboratory.



Accredited by the Swiss Accreditation Service (SAS)

Accreditation No.: **SCS 0108**

The Swiss Accreditation Service is one of the signatories to the EA Multilateral Agreement for the recognition of calibration certificates

Glossary:

TSL	tissue simulating liquid
NORM _{x,y,z}	sensitivity in free space
ConvF	sensitivity in TSL / NORM _{x,y,z}
DCP	diode compression point
CF	crest factor (1/duty_cycle) of the RF signal
A, B, C, D	modulation dependent linearization parameters
Polarization φ	φ rotation around probe axis
Polarization ϑ	ϑ rotation around an axis that is in the plane normal to probe axis (at measurement center), i.e., ϑ = 0 is normal to probe axis
Connector Angle	information used in DASY system to align probe sensor X to the robot coordinate system

Calibration is Performed According to the Following Standards:

- a) IEEE Std 1528-2013, "IEEE Recommended Practice for Determining the Peak Spatial-Averaged Specific Absorption Rate (SAR) in the Human Head from Wireless Communications Devices: Measurement Techniques", June 2013
- b) IEC 62209-1, "Measurement procedure for the assessment of Specific Absorption Rate (SAR) from hand-held and body-mounted devices used next to the ear (frequency range of 300 MHz to 6 GHz)", July 2016
- c) IEC 62209-2, "Procedure to determine the Specific Absorption Rate (SAR) for wireless communication devices used in close proximity to the human body (frequency range of 30 MHz to 6 GHz)", March 2010
- d) KDB 865664, "SAR Measurement Requirements for 100 MHz to 6 GHz"

Methods Applied and Interpretation of Parameters:

- *NORM_{x,y,z}*: Assessed for E-field polarization ϑ = 0 (f ≤ 900 MHz in TEM-cell; f > 1800 MHz: R22 waveguide). *NORM_{x,y,z}* are only intermediate values, i.e., the uncertainties of *NORM_{x,y,z}* does not affect the E²-field uncertainty inside TSL (see below *ConvF*).
- *NORM(f)_{x,y,z}* = *NORM_{x,y,z}* * *frequency_response* (see Frequency Response Chart). This linearization is implemented in DASY4 software versions later than 4.2. The uncertainty of the frequency response is included in the stated uncertainty of *ConvF*.
- *DCP_{x,y,z}*: DCP are numerical linearization parameters assessed based on the data of power sweep with CW signal (no uncertainty required). DCP does not depend on frequency nor media.
- *PAR*: PAR is the Peak to Average Ratio that is not calibrated but determined based on the signal characteristics
- *A_{x,y,z}; B_{x,y,z}; C_{x,y,z}; D_{x,y,z}; VR_{x,y,z}*: *A, B, C, D* are numerical linearization parameters assessed based on the data of power sweep for specific modulation signal. The parameters do not depend on frequency nor media. *VR* is the maximum calibration range expressed in RMS voltage across the diode.
- *ConvF and Boundary Effect Parameters*: Assessed in flat phantom using E-field (or Temperature Transfer Standard for f ≤ 800 MHz) and inside waveguide using analytical field distributions based on power measurements for f > 800 MHz. The same setups are used for assessment of the parameters applied for boundary compensation (alpha, depth) of which typical uncertainty values are given. These parameters are used in DASY4 software to improve probe accuracy close to the boundary. The sensitivity in TSL corresponds to *NORM_{x,y,z}* * *ConvF* whereby the uncertainty corresponds to that given for *ConvF*. A frequency dependent *ConvF* is used in DASY version 4.4 and higher which allows extending the validity from ± 50 MHz to ± 100 MHz.
- *Spherical isotropy (3D deviation from isotropy)*: in a field of low gradients realized using a flat phantom exposed by a patch antenna.
- *Sensor Offset*: The sensor offset corresponds to the offset of virtual measurement center from the probe tip (on probe axis). No tolerance required.
- *Connector Angle*: The angle is assessed using the information gained by determining the *NORM_x* (no uncertainty required).

Probe EX3DV4

SN:3693

Manufactured: April 22, 2009
Calibrated: August 27, 2018

Calibrated for DASY/EASY Systems
(Note: non-compatible with DASY2 system!)

DASY/EASY - Parameters of Probe: EX3DV4 - SN:3693

Basic Calibration Parameters

	Sensor X	Sensor Y	Sensor Z	Unc (k=2)
Norm ($\mu\text{V}/(\text{V}/\text{m})^2$) ^A	0.39	0.30	0.35	$\pm 10.1\%$
DCP (mV) ^B	96.9	97.3	107.3	

Modulation Calibration Parameters

UID	Communication System Name		A dB	B dB $\sqrt{\mu\text{V}}$	C	D dB	VR mV	Unc ^E (k=2)
0	CW	X	0.0	0.0	1.0	0.00	133.1	$\pm 1.7\%$
		Y	0.0	0.0	1.0		130.6	
		Z	0.0	0.0	1.0		133.5	

Note: For details on UID parameters see Appendix.

Sensor Model Parameters

	C1 fF	C2 fF	α V^{-1}	T1 $\text{ms}\cdot\text{V}^{-2}$	T2 $\text{ms}\cdot\text{V}^{-1}$	T3 ms	T4 V^{-2}	T5 V^{-1}	T6
X	32.78	256.2	38.66	10.42	1.187	5.061	0.000	0.479	1.010
Y	38.15	291.7	37.34	12.40	1.152	4.996	0.986	0.358	1.004
Z	26.99	197.7	34.43	5.333	0.521	5.037	0.437	0.333	1.004

The reported uncertainty of measurement is stated as the standard uncertainty of measurement multiplied by the coverage factor $k=2$, which for a normal distribution corresponds to a coverage probability of approximately 95%.

^A The uncertainties of Norm X,Y,Z do not affect the E^2 -field uncertainty inside TSL (see Pages 5 and 6).

^B Numerical linearization parameter: uncertainty not required.

^E Uncertainty is determined using the max. deviation from linear response applying rectangular distribution and is expressed for the square of the field value.

DASY/EASY - Parameters of Probe: EX3DV4 - SN:3693

Calibration Parameter Determined in Head Tissue Simulating Media

f (MHz) ^C	Relative Permittivity ^F	Conductivity (S/m) ^F	ConvF X	ConvF Y	ConvF Z	Alpha ^G	Depth ^G (mm)	Unc (k=2)
750	41.9	0.89	9.64	9.64	9.64	0.55	0.84	± 12.0 %
835	41.5	0.90	9.37	9.37	9.37	0.37	0.97	± 12.0 %
900	41.5	0.97	9.16	9.16	9.16	0.53	0.80	± 12.0 %
1750	40.1	1.37	8.10	8.10	8.10	0.31	0.86	± 12.0 %
1900	40.0	1.40	7.78	7.78	7.78	0.28	0.90	± 12.0 %
2300	39.5	1.67	7.42	7.42	7.42	0.32	0.92	± 12.0 %
2450	39.2	1.80	6.95	6.95	6.95	0.35	0.92	± 12.0 %
2600	39.0	1.96	6.90	6.90	6.90	0.30	0.99	± 12.0 %
5250	35.9	4.71	4.96	4.96	4.96	0.40	1.80	± 13.1 %
5600	35.5	5.07	4.77	4.77	4.77	0.40	1.80	± 13.1 %
5750	35.4	5.22	4.67	4.67	4.67	0.40	1.80	± 13.1 %

^C Frequency validity above 300 MHz of ± 100 MHz only applies for DASY v4.4 and higher (see Page 2), else it is restricted to ± 50 MHz. The uncertainty is the RSS of the ConvF uncertainty at calibration frequency and the uncertainty for the indicated frequency band. Frequency validity below 300 MHz is ± 10, 25, 40, 50 and 70 MHz for ConvF assessments at 30, 64, 128, 150 and 220 MHz respectively. Above 5 GHz frequency validity can be extended to ± 110 MHz.

^F At frequencies below 3 GHz, the validity of tissue parameters (ϵ and σ) can be relaxed to ± 10% if liquid compensation formula is applied to measured SAR values. At frequencies above 3 GHz, the validity of tissue parameters (ϵ and σ) is restricted to ± 5%. The uncertainty is the RSS of the ConvF uncertainty for indicated target tissue parameters.

^G Alpha/Depth are determined during calibration. SPEAG warrants that the remaining deviation due to the boundary effect after compensation is always less than ± 1% for frequencies below 3 GHz and below ± 2% for frequencies between 3-6 GHz at any distance larger than half the probe tip diameter from the boundary.

DASY/EASY - Parameters of Probe: EX3DV4 - SN:3693

Calibration Parameter Determined in Body Tissue Simulating Media

f (MHz) ^C	Relative Permittivity ^F	Conductivity (S/m) ^F	ConvF X	ConvF Y	ConvF Z	Alpha ^G	Depth ^G (mm)	Unc (k=2)
750	55.5	0.96	9.77	9.77	9.77	0.46	0.85	± 12.0 %
835	55.2	0.97	9.40	9.40	9.40	0.43	0.89	± 12.0 %
900	55.0	1.05	9.25	9.25	9.25	0.39	0.93	± 12.0 %
1750	53.4	1.49	7.77	7.77	7.77	0.32	0.89	± 12.0 %
1900	53.3	1.52	7.44	7.44	7.44	0.40	0.93	± 12.0 %
2300	52.9	1.81	7.43	7.43	7.43	0.40	0.90	± 12.0 %
2450	52.7	1.95	7.29	7.29	7.29	0.31	0.95	± 12.0 %
2600	52.5	2.16	7.13	7.13	7.13	0.29	1.05	± 12.0 %
5250	48.9	5.36	4.46	4.46	4.46	0.50	1.90	± 13.1 %
5600	48.5	5.77	3.91	3.91	3.91	0.50	1.90	± 13.1 %
5750	48.3	5.94	4.05	4.05	4.05	0.50	1.90	± 13.1 %

^C Frequency validity above 300 MHz of ± 100 MHz only applies for DASY v4.4 and higher (see Page 2), else it is restricted to ± 50 MHz. The uncertainty is the RSS of the ConvF uncertainty at calibration frequency and the uncertainty for the indicated frequency band. Frequency validity below 300 MHz is ± 10, 25, 40, 50 and 70 MHz for ConvF assessments at 30, 64, 128, 150 and 220 MHz respectively. Above 5 GHz frequency validity can be extended to ± 110 MHz.

^F At frequencies below 3 GHz, the validity of tissue parameters (ϵ and σ) can be relaxed to ± 10% if liquid compensation formula is applied to measured SAR values. At frequencies above 3 GHz, the validity of tissue parameters (ϵ and σ) is restricted to ± 5%. The uncertainty is the RSS of the ConvF uncertainty for indicated target tissue parameters.

^G Alpha/Depth are determined during calibration. SPEAG warrants that the remaining deviation due to the boundary effect after compensation is always less than ± 1% for frequencies below 3 GHz and below ± 2% for frequencies between 3-6 GHz at any distance larger than half the probe tip diameter from the boundary.

Frequency Response of E-Field (TEM-Cell:ifi110 EXX, Waveguide: R22)

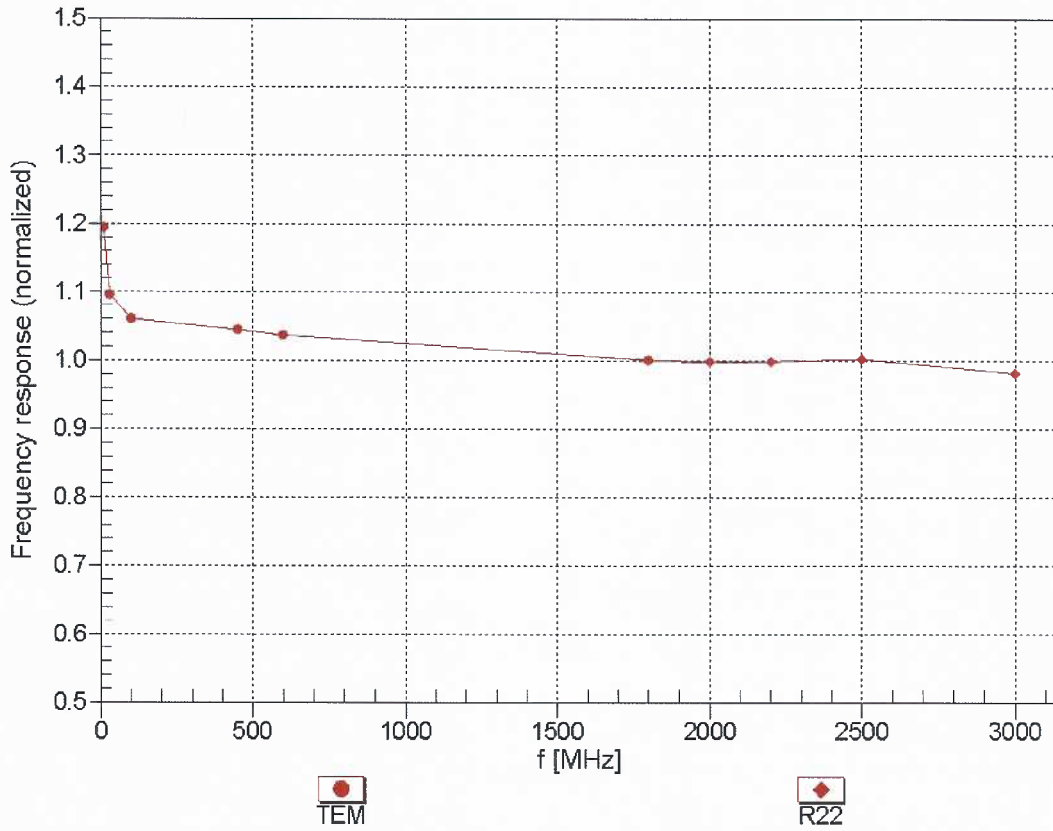

Uncertainty of Frequency Response of E-field: $\pm 6.3\%$ (k=2)

Receiving Pattern (ϕ), $\vartheta = 0^\circ$

f=600 MHz,TEM

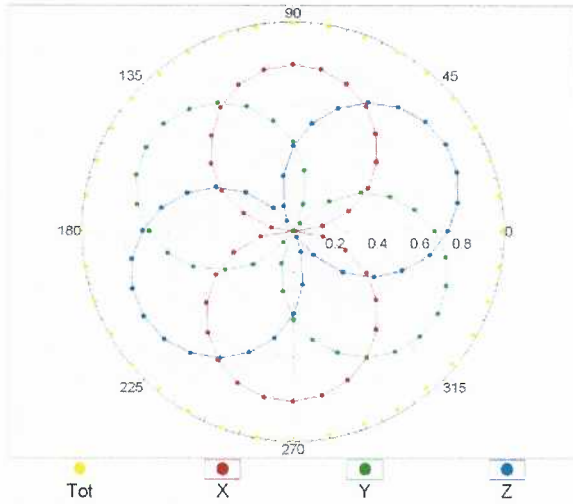

f=1800 MHz,R22

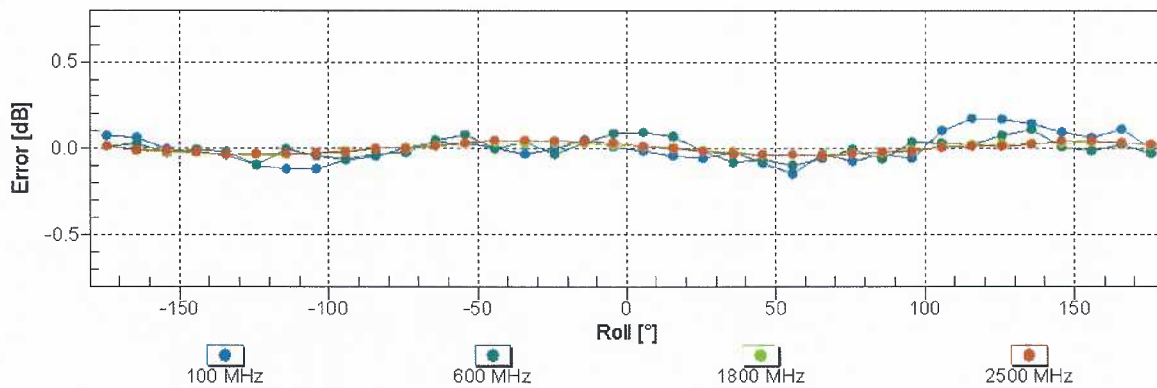
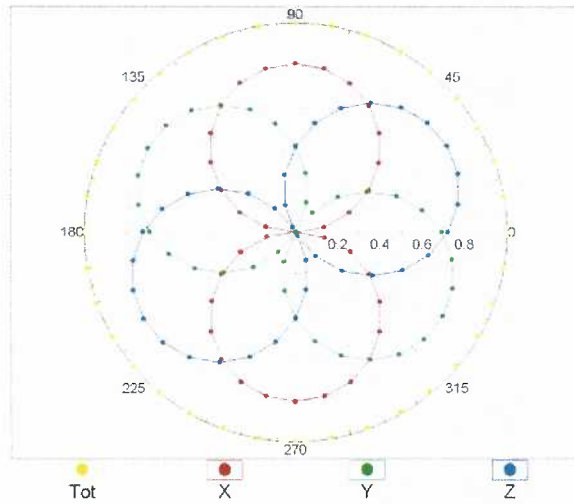

Uncertainty of Axial Isotropy Assessment: $\pm 0.5\%$ (k=2)

Dynamic Range f(SAR_{head}) (TEM cell , f_{eval}= 1900 MHz)

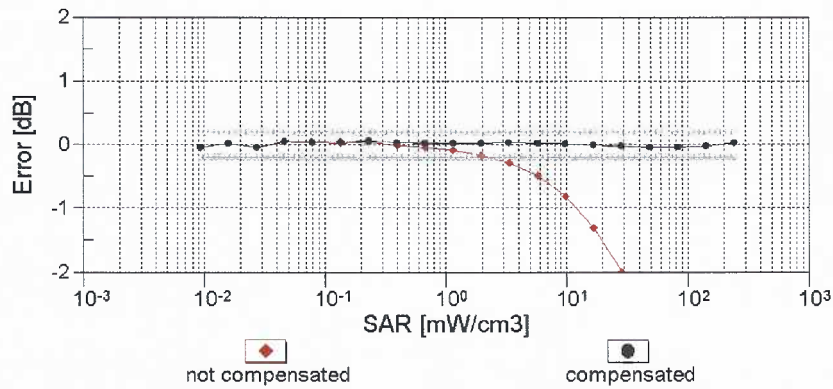
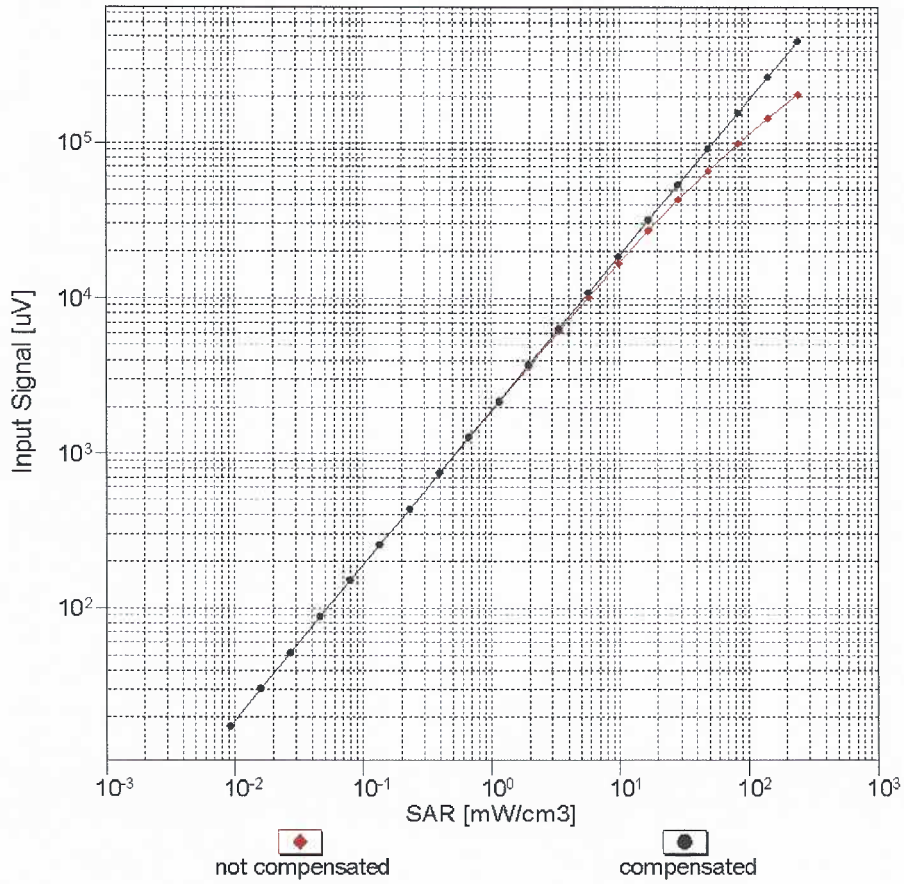

Uncertainty of Linearity Assessment: ± 0.6% (k=2)

Conversion Factor Assessment

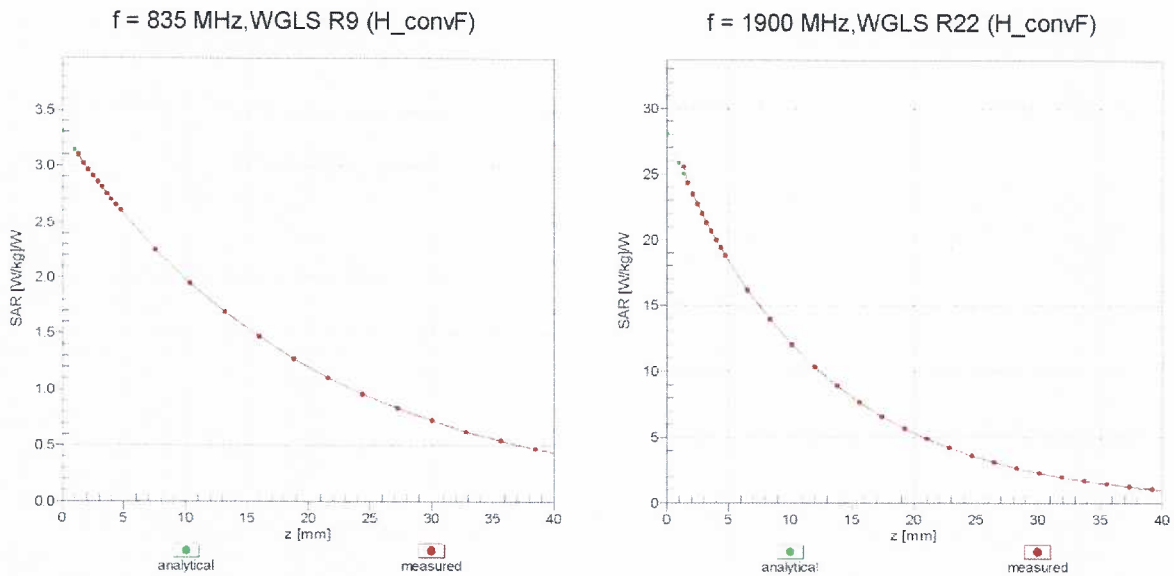

Deviation from Isotropy in Liquid Error (ϕ, θ), f = 900 MHz

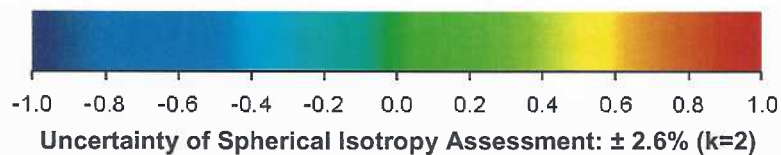
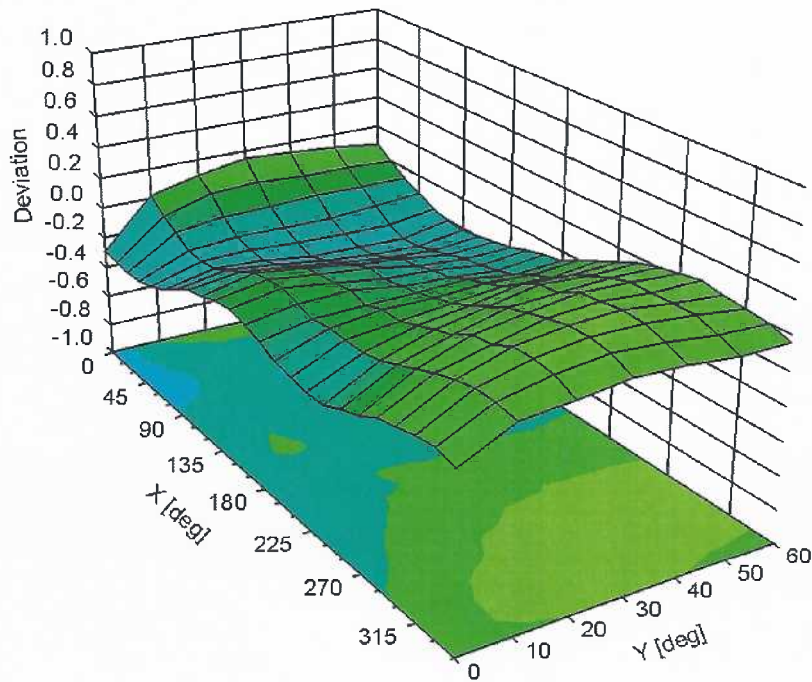

DASY/EASY - Parameters of Probe: EX3DV4 - SN:3693

Other Probe Parameters

Sensor Arrangement	Triangular
Connector Angle (°)	105.7
Mechanical Surface Detection Mode	enabled
Optical Surface Detection Mode	disabled
Probe Overall Length	337 mm
Probe Body Diameter	10 mm
Tip Length	9 mm
Tip Diameter	2.5 mm
Probe Tip to Sensor X Calibration Point	1 mm
Probe Tip to Sensor Y Calibration Point	1 mm
Probe Tip to Sensor Z Calibration Point	1 mm
Recommended Measurement Distance from Surface	1.4 mm

Appendix: Modulation Calibration Parameters

UID	Communication System Name		A dB	B dB $\sqrt{\mu V}$	C	D dB	VR mV	Max Unc ^E (k=2)
0	CW	X	0.00	0.00	1.00	0.00	133.1	$\pm 1.7\%$
		Y	0.00	0.00	1.00		130.6	
		Z	0.00	0.00	1.00		133.5	
10010- CAA	SAR Validation (Square, 100ms, 10ms)	X	2.51	65.57	10.47	10.00	20.0	$\pm 9.6\%$
		Y	2.40	65.09	10.16		20.0	
		Z	1.89	63.20	8.39		20.0	
10011- CAB	UMTS-FDD (WCDMA)	X	0.91	68.37	14.94	0.00	150.0	$\pm 9.6\%$
		Y	1.35	74.07	18.63		150.0	
		Z	0.82	66.98	14.05		150.0	
10012- CAB	IEEE 802.11b WiFi 2.4 GHz (DSSS, 1 Mbps)	X	1.06	64.24	15.41	0.41	150.0	$\pm 9.6\%$
		Y	1.17	65.38	16.46		150.0	
		Z	1.03	63.69	14.73		150.0	
10013- CAB	IEEE 802.11g WiFi 2.4 GHz (DSSS-OFDM, 6 Mbps)	X	4.62	66.97	17.24	1.46	150.0	$\pm 9.6\%$
		Y	4.73	66.91	17.24		150.0	
		Z	4.44	66.96	16.86		150.0	
10021- DAC	GSM-FDD (TDMA, GMSK)	X	100.00	113.69	27.59	9.39	50.0	$\pm 9.6\%$
		Y	15.92	88.65	20.46		50.0	
		Z	100.00	107.55	24.08		50.0	
10023- DAC	GPRS-FDD (TDMA, GMSK, TN 0)	X	100.00	113.26	27.45	9.57	50.0	$\pm 9.6\%$
		Y	10.59	83.36	18.82		50.0	
		Z	35.50	95.64	21.13		50.0	
10024- DAC	GPRS-FDD (TDMA, GMSK, TN 0-1)	X	100.00	110.83	25.00	6.56	60.0	$\pm 9.6\%$
		Y	100.00	107.89	23.67		60.0	
		Z	100.00	105.51	21.87		60.0	
10025- DAC	EDGE-FDD (TDMA, 8PSK, TN 0)	X	3.94	66.80	23.64	12.57	50.0	$\pm 9.6\%$
		Y	4.42	70.18	25.25		50.0	
		Z	3.29	63.55	21.61		50.0	
10026- DAC	EDGE-FDD (TDMA, 8PSK, TN 0-1)	X	8.10	88.70	31.28	9.56	60.0	$\pm 9.6\%$
		Y	8.90	90.14	31.40		60.0	
		Z	5.79	82.38	28.74		60.0	
10027- DAC	GPRS-FDD (TDMA, GMSK, TN 0-1-2)	X	100.00	109.25	23.40	4.80	80.0	$\pm 9.6\%$
		Y	100.00	106.54	22.28		80.0	
		Z	100.00	104.71	20.66		80.0	
10028- DAC	GPRS-FDD (TDMA, GMSK, TN 0-1-2-3)	X	100.00	107.37	21.81	3.55	100.0	$\pm 9.6\%$
		Y	100.00	106.10	21.41		100.0	
		Z	100.00	103.48	19.41		100.0	
10029- DAC	EDGE-FDD (TDMA, 8PSK, TN 0-1-2)	X	5.40	80.16	26.89	7.80	80.0	$\pm 9.6\%$
		Y	5.81	81.12	26.89		80.0	
		Z	3.99	74.82	24.51		80.0	
10030- CAA	IEEE 802.15.1 Bluetooth (GFSK, DH1)	X	100.00	107.75	23.04	5.30	70.0	$\pm 9.6\%$
		Y	100.00	105.38	22.04		70.0	
		Z	100.00	102.15	19.84		70.0	
10031- CAA	IEEE 802.15.1 Bluetooth (GFSK, DH3)	X	0.32	60.24	5.01	1.88	100.0	$\pm 9.6\%$
		Y	100.00	98.91	17.16		100.0	
		Z	0.21	60.00	4.08		100.0	

10032-CAA	IEEE 802.15.1 Bluetooth (GFSK, DH5)	X	49.70	283.71	16.38	1.17	100.0	± 9.6 %
		Y	100.00	94.28	14.55		100.0	
		Z	21.39	60.54	1.42		100.0	
10033-CAA	IEEE 802.15.1 Bluetooth (PI/4-DQPSK, DH1)	X	10.55	88.91	21.86	5.30	70.0	± 9.6 %
		Y	7.04	83.33	20.28		70.0	
		Z	5.31	79.96	17.86		70.0	
10034-CAA	IEEE 802.15.1 Bluetooth (PI/4-DQPSK, DH3)	X	1.97	70.15	12.93	1.88	100.0	± 9.6 %
		Y	3.62	77.97	16.97		100.0	
		Z	1.05	64.71	9.63		100.0	
10035-CAA	IEEE 802.15.1 Bluetooth (PI/4-DQPSK, DH5)	X	1.21	66.21	10.77	1.17	100.0	± 9.6 %
		Y	2.71	75.92	16.05		100.0	
		Z	0.74	62.66	8.21		100.0	
10036-CAA	IEEE 802.15.1 Bluetooth (8-DPSK, DH1)	X	16.37	95.16	23.78	5.30	70.0	± 9.6 %
		Y	9.05	87.03	21.55		70.0	
		Z	7.29	84.15	19.32		70.0	
10037-CAA	IEEE 802.15.1 Bluetooth (8-DPSK, DH3)	X	1.77	69.16	12.52	1.88	100.0	± 9.6 %
		Y	3.14	76.38	16.39		100.0	
		Z	0.98	64.10	9.34		100.0	
10038-CAA	IEEE 802.15.1 Bluetooth (8-DPSK, DH5)	X	1.24	66.70	11.11	1.17	100.0	± 9.6 %
		Y	2.88	76.97	16.58		100.0	
		Z	0.76	62.89	8.45		100.0	
10039-CAB	CDMA2000 (1xRTT, RC1)	X	0.64	62.07	7.96	0.00	150.0	± 9.6 %
		Y	4.76	84.60	18.89		150.0	
		Z	0.45	60.19	6.19		150.0	
10042-CAB	IS-54 / IS-136 FDD (TDMA/FDM, PI/4-DQPSK, Halfrate)	X	100.00	108.14	24.10	7.78	50.0	± 9.6 %
		Y	8.20	80.05	16.33		50.0	
		Z	9.72	81.12	15.57		50.0	
10044-CAA	IS-91/EIA/TIA-553 FDD (FDMA, FM)	X	0.00	65.80	22.18	0.00	150.0	± 9.6 %
		Y	0.05	126.22	5.06		150.0	
		Z	0.16	126.88	0.43		150.0	
10048-CAA	DECT (TDD, TDMA/FDM, GFSK, Full Slot, 24)	X	10.50	80.73	19.78	13.80	25.0	± 9.6 %
		Y	6.27	73.47	16.77		25.0	
		Z	6.57	72.48	15.23		25.0	
10049-CAA	DECT (TDD, TDMA/FDM, GFSK, Double Slot, 12)	X	13.23	86.11	20.42	10.79	40.0	± 9.6 %
		Y	6.76	76.65	16.75		40.0	
		Z	6.92	76.03	15.42		40.0	
10056-CAA	UMTS-TDD (TD-SCDMA, 1.28 Mcps)	X	12.01	87.16	22.22	9.03	50.0	± 9.6 %
		Y	8.86	82.28	20.46		50.0	
		Z	10.91	84.91	20.22		50.0	
10058-DAC	EDGE-FDD (TDMA, 8PSK, TN 0-1-2-3)	X	4.26	75.92	24.41	6.55	100.0	± 9.6 %
		Y	4.53	76.62	24.38		100.0	
		Z	3.28	71.52	22.33		100.0	
10059-CAB	IEEE 802.11b WiFi 2.4 GHz (DSSS, 2 Mbps)	X	1.12	65.70	16.18	0.61	110.0	± 9.6 %
		Y	1.24	66.83	17.14		110.0	
		Z	1.04	64.56	15.22		110.0	
10060-CAB	IEEE 802.11b WiFi 2.4 GHz (DSSS, 5.5 Mbps)	X	100.00	134.39	33.58	1.30	110.0	± 9.6 %
		Y	100.00	136.71	34.87		110.0	
		Z	12.40	108.39	28.07		110.0	

10061-CAB	IEEE 802.11b WiFi 2.4 GHz (DSSS, 11 Mbps)	X	4.70	89.70	25.19	2.04	110.0	± 9.6 %
		Y	4.44	87.85	24.54		110.0	
		Z	2.03	77.34	20.69		110.0	
10062-CAC	IEEE 802.11a/h WiFi 5 GHz (OFDM, 6 Mbps)	X	4.38	66.79	16.57	0.49	100.0	± 9.6 %
		Y	4.54	66.95	16.76		100.0	
		Z	4.22	66.86	16.25		100.0	
10063-CAC	IEEE 802.11a/h WiFi 5 GHz (OFDM, 9 Mbps)	X	4.41	66.93	16.69	0.72	100.0	± 9.6 %
		Y	4.56	67.04	16.83		100.0	
		Z	4.24	66.98	16.36		100.0	
10064-CAC	IEEE 802.11a/h WiFi 5 GHz (OFDM, 12 Mbps)	X	4.64	67.13	16.89	0.86	100.0	± 9.6 %
		Y	4.80	67.21	17.01		100.0	
		Z	4.45	67.14	16.54		100.0	
10065-CAC	IEEE 802.11a/h WiFi 5 GHz (OFDM, 18 Mbps)	X	4.53	67.01	16.99	1.21	100.0	± 9.6 %
		Y	4.68	67.08	17.07		100.0	
		Z	4.33	66.96	16.60		100.0	
10066-CAC	IEEE 802.11a/h WiFi 5 GHz (OFDM, 24 Mbps)	X	4.55	67.05	17.17	1.46	100.0	± 9.6 %
		Y	4.69	67.08	17.21		100.0	
		Z	4.34	66.93	16.73		100.0	
10067-CAC	IEEE 802.11a/h WiFi 5 GHz (OFDM, 36 Mbps)	X	4.86	67.41	17.69	2.04	100.0	± 9.6 %
		Y	4.98	67.30	17.64		100.0	
		Z	4.60	67.16	17.18		100.0	
10068-CAC	IEEE 802.11a/h WiFi 5 GHz (OFDM, 48 Mbps)	X	4.91	67.37	17.88	2.55	100.0	± 9.6 %
		Y	5.01	67.22	17.78		100.0	
		Z	4.67	67.20	17.41		100.0	
10069-CAC	IEEE 802.11a/h WiFi 5 GHz (OFDM, 54 Mbps)	X	4.98	67.41	18.07	2.67	100.0	± 9.6 %
		Y	5.09	67.26	17.97		100.0	
		Z	4.70	67.15	17.55		100.0	
10071-CAB	IEEE 802.11g WiFi 2.4 GHz (DSSS/OFDM, 9 Mbps)	X	4.74	67.09	17.56	1.99	100.0	± 9.6 %
		Y	4.83	66.96	17.50		100.0	
		Z	4.54	67.04	17.16		100.0	
10072-CAB	IEEE 802.11g WiFi 2.4 GHz (DSSS/OFDM, 12 Mbps)	X	4.71	67.40	17.79	2.30	100.0	± 9.6 %
		Y	4.80	67.26	17.69		100.0	
		Z	4.48	67.21	17.32		100.0	
10073-CAB	IEEE 802.11g WiFi 2.4 GHz (DSSS/OFDM, 18 Mbps)	X	4.81	67.70	18.18	2.83	100.0	± 9.6 %
		Y	4.87	67.45	18.00		100.0	
		Z	4.56	67.46	17.69		100.0	
10074-CAB	IEEE 802.11g WiFi 2.4 GHz (DSSS/OFDM, 24 Mbps)	X	4.84	67.73	18.37	3.30	100.0	± 9.6 %
		Y	4.88	67.39	18.13		100.0	
		Z	4.59	67.52	17.89		100.0	
10075-CAB	IEEE 802.11g WiFi 2.4 GHz (DSSS/OFDM, 36 Mbps)	X	4.89	67.79	18.64	3.82	90.0	± 9.6 %
		Y	4.92	67.45	18.38		90.0	
		Z	4.63	67.54	18.14		90.0	
10076-CAB	IEEE 802.11g WiFi 2.4 GHz (DSSS/OFDM, 48 Mbps)	X	4.95	67.71	18.84	4.15	90.0	± 9.6 %
		Y	4.96	67.32	18.54		90.0	
		Z	4.68	67.42	18.31		90.0	
10077-CAB	IEEE 802.11g WiFi 2.4 GHz (DSSS/OFDM, 54 Mbps)	X	4.99	67.84	18.96	4.30	90.0	± 9.6 %
		Y	5.00	67.42	18.65		90.0	
		Z	4.72	67.54	18.44		90.0	

10081-CAB	CDMA2000 (1xRTT, RC3)	X	0.35	60.00	5.91	0.00	150.0	± 9.6 %
		Y	0.93	68.99	12.63		150.0	
		Z	0.31	60.00	5.31		150.0	
10082-CAB	IS-54 / IS-136 FDD (TDMA/FDM, PI/4-DQPSK, Fullrate)	X	0.74	60.00	4.42	4.77	80.0	± 9.6 %
		Y	0.78	60.00	4.54		80.0	
		Z	0.63	60.00	3.21		80.0	
10090-DAC	GPRS-FDD (TDMA, GMSK, TN 0-4)	X	100.00	110.96	25.08	6.56	60.0	± 9.6 %
		Y	100.00	107.95	23.71		60.0	
		Z	100.00	105.61	21.93		60.0	
10097-CAB	UMTS-FDD (HSDPA)	X	1.73	68.88	15.45	0.00	150.0	± 9.6 %
		Y	2.11	71.60	17.53		150.0	
		Z	1.64	68.63	14.86		150.0	
10098-CAB	UMTS-FDD (HSUPA, Subtest 2)	X	1.69	68.83	15.43	0.00	150.0	± 9.6 %
		Y	2.06	71.60	17.53		150.0	
		Z	1.60	68.55	14.84		150.0	
10099-DAC	EDGE-FDD (TDMA, 8PSK, TN 0-4)	X	8.15	88.80	31.31	9.56	60.0	± 9.6 %
		Y	8.95	90.21	31.41		60.0	
		Z	5.83	82.50	28.78		60.0	
10100-CAE	LTE-FDD (SC-FDMA, 100% RB, 20 MHz, QPSK)	X	2.86	70.20	16.73	0.00	150.0	± 9.6 %
		Y	3.31	72.31	17.94		150.0	
		Z	2.70	69.79	16.38		150.0	
10101-CAE	LTE-FDD (SC-FDMA, 100% RB, 20 MHz, 16-QAM)	X	2.97	67.29	15.87	0.00	150.0	± 9.6 %
		Y	3.22	68.29	16.58		150.0	
		Z	2.86	67.20	15.57		150.0	
10102-CAE	LTE-FDD (SC-FDMA, 100% RB, 20 MHz, 64-QAM)	X	3.08	67.33	16.00	0.00	150.0	± 9.6 %
		Y	3.32	68.25	16.66		150.0	
		Z	2.97	67.28	15.71		150.0	
10103-CAF	LTE-TDD (SC-FDMA, 100% RB, 20 MHz, QPSK)	X	5.99	75.93	20.73	3.98	65.0	± 9.6 %
		Y	6.07	75.29	20.20		65.0	
		Z	4.92	73.90	19.72		65.0	
10104-CAF	LTE-TDD (SC-FDMA, 100% RB, 20 MHz, 16-QAM)	X	5.78	73.18	20.28	3.98	65.0	± 9.6 %
		Y	6.05	73.33	20.14		65.0	
		Z	4.95	71.50	19.26		65.0	
10105-CAF	LTE-TDD (SC-FDMA, 100% RB, 20 MHz, 64-QAM)	X	5.44	71.81	19.96	3.98	65.0	± 9.6 %
		Y	5.66	71.91	19.81		65.0	
		Z	4.62	69.93	18.84		65.0	
10108-CAF	LTE-FDD (SC-FDMA, 100% RB, 10 MHz, QPSK)	X	2.46	69.75	16.61	0.00	150.0	± 9.6 %
		Y	2.87	71.83	17.90		150.0	
		Z	2.29	69.26	16.18		150.0	
10109-CAF	LTE-FDD (SC-FDMA, 100% RB, 10 MHz, 16-QAM)	X	2.61	67.38	15.71	0.00	150.0	± 9.6 %
		Y	2.88	68.51	16.60		150.0	
		Z	2.50	67.30	15.35		150.0	
10110-CAF	LTE-FDD (SC-FDMA, 100% RB, 5 MHz, QPSK)	X	1.94	69.06	15.97	0.00	150.0	± 9.6 %
		Y	2.36	71.54	17.68		150.0	
		Z	1.77	68.41	15.33		150.0	
10111-CAF	LTE-FDD (SC-FDMA, 100% RB, 5 MHz, 16-QAM)	X	2.37	68.86	15.85	0.00	150.0	± 9.6 %
		Y	2.75	70.67	17.33		150.0	
		Z	2.26	68.83	15.37		150.0	

10112-CAF	LTE-FDD (SC-FDMA, 100% RB, 10 MHz, 64-QAM)	X	2.74	67.47	15.80	0.00	150.0	± 9.6 %
		Y	3.01	68.49	16.64		150.0	
		Z	2.63	67.46	15.47		150.0	
10113-CAF	LTE-FDD (SC-FDMA, 100% RB, 5 MHz, 64-QAM)	X	2.52	69.06	16.02	0.00	150.0	± 9.6 %
		Y	2.90	70.76	17.42		150.0	
		Z	2.40	69.05	15.53		150.0	
10114-CAC	IEEE 802.11n (HT Greenfield, 13.5 Mbps, BPSK)	X	4.85	67.10	16.54	0.00	150.0	± 9.6 %
		Y	5.01	67.40	16.77		150.0	
		Z	4.69	67.08	16.26		150.0	
10115-CAC	IEEE 802.11n (HT Greenfield, 81 Mbps, 16-QAM)	X	5.09	67.17	16.57	0.00	150.0	± 9.6 %
		Y	5.27	67.46	16.79		150.0	
		Z	4.91	67.15	16.27		150.0	
10116-CAC	IEEE 802.11n (HT Greenfield, 135 Mbps, 64-QAM)	X	4.92	67.25	16.54	0.00	150.0	± 9.6 %
		Y	5.11	67.62	16.80		150.0	
		Z	4.75	67.24	16.26		150.0	
10117-CAC	IEEE 802.11n (HT Mixed, 13.5 Mbps, BPSK)	X	4.82	66.96	16.49	0.00	150.0	± 9.6 %
		Y	5.00	67.35	16.76		150.0	
		Z	4.67	66.99	16.23		150.0	
10118-CAC	IEEE 802.11n (HT Mixed, 81 Mbps, 16-QAM)	X	5.18	67.44	16.71	0.00	150.0	± 9.6 %
		Y	5.35	67.70	16.92		150.0	
		Z	4.97	67.29	16.35		150.0	
10119-CAC	IEEE 802.11n (HT Mixed, 135 Mbps, 64-QAM)	X	4.93	67.30	16.57	0.00	150.0	± 9.6 %
		Y	5.10	67.61	16.81		150.0	
		Z	4.76	67.27	16.28		150.0	
10140-CAE	LTE-FDD (SC-FDMA, 100% RB, 15 MHz, 16-QAM)	X	3.09	67.34	15.89	0.00	150.0	± 9.6 %
		Y	3.34	68.25	16.56		150.0	
		Z	2.97	67.29	15.60		150.0	
10141-CAE	LTE-FDD (SC-FDMA, 100% RB, 15 MHz, 64-QAM)	X	3.22	67.55	16.12	0.00	150.0	± 9.6 %
		Y	3.47	68.39	16.75		150.0	
		Z	3.11	67.58	15.86		150.0	
10142-CAE	LTE-FDD (SC-FDMA, 100% RB, 3 MHz, QPSK)	X	1.65	68.54	14.75	0.00	150.0	± 9.6 %
		Y	2.23	72.50	17.47		150.0	
		Z	1.45	67.51	13.76		150.0	
10143-CAE	LTE-FDD (SC-FDMA, 100% RB, 3 MHz, 16-QAM)	X	2.04	68.18	14.12	0.00	150.0	± 9.6 %
		Y	2.77	72.39	17.05		150.0	
		Z	1.79	67.15	12.96		150.0	
10144-CAE	LTE-FDD (SC-FDMA, 100% RB, 3 MHz, 64-QAM)	X	1.68	64.77	11.84	0.00	150.0	± 9.6 %
		Y	2.17	67.69	14.28		150.0	
		Z	1.45	63.78	10.64		150.0	
10145-CAF	LTE-FDD (SC-FDMA, 100% RB, 1.4 MHz, QPSK)	X	0.57	60.00	5.87	0.00	150.0	± 9.6 %
		Y	0.86	62.73	9.11		150.0	
		Z	0.48	60.00	5.03		150.0	
10146-CAF	LTE-FDD (SC-FDMA, 100% RB, 1.4 MHz, 16-QAM)	X	0.85	60.00	5.89	0.00	150.0	± 9.6 %
		Y	1.15	61.47	7.56		150.0	
		Z	0.69	60.00	4.71		150.0	
10147-CAF	LTE-FDD (SC-FDMA, 100% RB, 1.4 MHz, 64-QAM)	X	0.86	60.00	5.95	0.00	150.0	± 9.6 %
		Y	1.22	62.00	7.94		150.0	
		Z	0.70	60.00	4.76		150.0	

10149-CAE	LTE-FDD (SC-FDMA, 50% RB, 20 MHz, 16-QAM)	X	2.62	67.46	15.77	0.00	150.0	± 9.6 %
		Y	2.89	68.60	16.66		150.0	
		Z	2.51	67.39	15.41		150.0	
10150-CAE	LTE-FDD (SC-FDMA, 50% RB, 20 MHz, 64-QAM)	X	2.75	67.54	15.86	0.00	150.0	± 9.6 %
		Y	3.02	68.57	16.69		150.0	
		Z	2.64	67.55	15.53		150.0	
10151-CAF	LTE-TDD (SC-FDMA, 50% RB, 20 MHz, QPSK)	X	6.60	79.47	22.11	3.98	65.0	± 9.6 %
		Y	6.59	78.37	21.43		65.0	
		Z	5.32	77.23	21.01		65.0	
10152-CAF	LTE-TDD (SC-FDMA, 50% RB, 20 MHz, 16-QAM)	X	5.33	73.23	19.77	3.98	65.0	± 9.6 %
		Y	5.58	73.27	19.68		65.0	
		Z	4.46	71.33	18.57		65.0	
10153-CAF	LTE-TDD (SC-FDMA, 50% RB, 20 MHz, 64-QAM)	X	5.80	74.65	20.79	3.98	65.0	± 9.6 %
		Y	6.01	74.50	20.60		65.0	
		Z	4.89	72.87	19.68		65.0	
10154-CAF	LTE-FDD (SC-FDMA, 50% RB, 10 MHz, QPSK)	X	1.99	69.55	16.25	0.00	150.0	± 9.6 %
		Y	2.44	72.19	18.04		150.0	
		Z	1.82	68.87	15.60		150.0	
10155-CAF	LTE-FDD (SC-FDMA, 50% RB, 10 MHz, 16-QAM)	X	2.38	68.92	15.90	0.00	150.0	± 9.6 %
		Y	2.75	70.72	17.36		150.0	
		Z	2.27	68.91	15.43		150.0	
10156-CAF	LTE-FDD (SC-FDMA, 50% RB, 5 MHz, QPSK)	X	1.40	67.46	13.55	0.00	150.0	± 9.6 %
		Y	2.14	73.17	17.29		150.0	
		Z	1.18	66.04	12.26		150.0	
10157-CAF	LTE-FDD (SC-FDMA, 50% RB, 5 MHz, 16-QAM)	X	1.42	64.20	10.93	0.00	150.0	± 9.6 %
		Y	2.05	68.56	14.27		150.0	
		Z	1.16	62.82	9.46		150.0	
10158-CAF	LTE-FDD (SC-FDMA, 50% RB, 10 MHz, 64-QAM)	X	2.53	69.18	16.09	0.00	150.0	± 9.6 %
		Y	2.91	70.88	17.49		150.0	
		Z	2.41	69.20	15.62		150.0	
10159-CAF	LTE-FDD (SC-FDMA, 50% RB, 5 MHz, 64-QAM)	X	1.47	64.37	11.06	0.00	150.0	± 9.6 %
		Y	2.17	69.13	14.58		150.0	
		Z	1.20	62.92	9.54		150.0	
10160-CAE	LTE-FDD (SC-FDMA, 50% RB, 15 MHz, QPSK)	X	2.54	69.31	16.47	0.00	150.0	± 9.6 %
		Y	2.87	70.85	17.58		150.0	
		Z	2.32	68.65	15.89		150.0	
10161-CAE	LTE-FDD (SC-FDMA, 50% RB, 15 MHz, 16-QAM)	X	2.63	67.51	15.68	0.00	150.0	± 9.6 %
		Y	2.92	68.64	16.63		150.0	
		Z	2.51	67.49	15.29		150.0	
10162-CAE	LTE-FDD (SC-FDMA, 50% RB, 15 MHz, 64-QAM)	X	2.75	67.78	15.85	0.00	150.0	± 9.6 %
		Y	3.03	68.85	16.76		150.0	
		Z	2.62	67.80	15.48		150.0	
10166-CAF	LTE-FDD (SC-FDMA, 50% RB, 1.4 MHz, QPSK)	X	3.17	69.88	19.75	3.01	150.0	± 9.6 %
		Y	3.43	70.48	19.76		150.0	
		Z	2.81	68.26	18.43		150.0	
10167-CAF	LTE-FDD (SC-FDMA, 50% RB, 1.4 MHz, 16-QAM)	X	3.81	72.89	20.15	3.01	150.0	± 9.6 %
		Y	4.38	74.23	20.42		150.0	
		Z	3.25	70.82	18.68		150.0	

10168-CAF	LTE-FDD (SC-FDMA, 50% RB, 1.4 MHz, 64-QAM)	X	4.50	76.69	22.26	3.01	150.0	± 9.6 %
		Y	5.20	77.95	22.40		150.0	
		Z	3.82	74.38	20.74		150.0	
10169-CAE	LTE-FDD (SC-FDMA, 1 RB, 20 MHz, QPSK)	X	2.60	68.07	18.92	3.01	150.0	± 9.6 %
		Y	2.86	69.54	19.35		150.0	
		Z	2.42	66.98	17.74		150.0	
10170-CAE	LTE-FDD (SC-FDMA, 1 RB, 20 MHz, 16-QAM)	X	3.49	74.33	21.57	3.01	150.0	± 9.6 %
		Y	4.36	77.73	22.58		150.0	
		Z	3.17	72.75	20.22		150.0	
10171-AAE	LTE-FDD (SC-FDMA, 1 RB, 20 MHz, 64-QAM)	X	2.78	69.40	18.22	3.01	150.0	± 9.6 %
		Y	3.30	71.79	18.96		150.0	
		Z	2.51	68.00	16.90		150.0	
10172-CAF	LTE-TDD (SC-FDMA, 1 RB, 20 MHz, QPSK)	X	5.91	86.87	27.62	6.02	65.0	± 9.6 %
		Y	6.32	86.01	26.16		65.0	
		Z	3.09	75.39	22.58		65.0	
10173-CAF	LTE-TDD (SC-FDMA, 1 RB, 20 MHz, 16-QAM)	X	13.09	98.55	29.49	6.02	65.0	± 9.6 %
		Y	12.30	93.80	26.59		65.0	
		Z	5.66	84.54	24.14		65.0	
10174-CAF	LTE-TDD (SC-FDMA, 1 RB, 20 MHz, 64-QAM)	X	8.21	89.21	25.92	6.02	65.0	± 9.6 %
		Y	7.97	85.68	23.40		65.0	
		Z	3.39	75.61	20.33		65.0	
10175-CAF	LTE-FDD (SC-FDMA, 1 RB, 10 MHz, QPSK)	X	2.56	67.73	18.64	3.01	150.0	± 9.6 %
		Y	2.82	69.16	19.06		150.0	
		Z	2.39	66.65	17.46		150.0	
10176-CAF	LTE-FDD (SC-FDMA, 1 RB, 10 MHz, 16-QAM)	X	3.50	74.35	21.59	3.01	150.0	± 9.6 %
		Y	4.37	77.76	22.59		150.0	
		Z	3.17	72.78	20.23		150.0	
10177-CAH	LTE-FDD (SC-FDMA, 1 RB, 5 MHz, QPSK)	X	2.58	67.87	18.72	3.01	150.0	± 9.6 %
		Y	2.85	69.33	19.15		150.0	
		Z	2.40	66.77	17.53		150.0	
10178-CAF	LTE-FDD (SC-FDMA, 1 RB, 5 MHz, 16-QAM)	X	3.47	74.17	21.48	3.01	150.0	± 9.6 %
		Y	4.32	77.50	22.46		150.0	
		Z	3.15	72.62	20.14		150.0	
10179-CAF	LTE-FDD (SC-FDMA, 1 RB, 10 MHz, 64-QAM)	X	3.09	71.68	19.74	3.01	150.0	± 9.6 %
		Y	3.76	74.51	20.58		150.0	
		Z	2.79	70.11	18.36		150.0	
10180-CAF	LTE-FDD (SC-FDMA, 1 RB, 5 MHz, 64-QAM)	X	2.78	69.36	18.19	3.01	150.0	± 9.6 %
		Y	3.29	71.72	18.91		150.0	
		Z	2.51	67.97	16.87		150.0	
10181-CAE	LTE-FDD (SC-FDMA, 1 RB, 15 MHz, QPSK)	X	2.58	67.85	18.72	3.01	150.0	± 9.6 %
		Y	2.84	69.31	19.15		150.0	
		Z	2.40	66.75	17.53		150.0	
10182-CAE	LTE-FDD (SC-FDMA, 1 RB, 15 MHz, 16-QAM)	X	3.46	74.14	21.47	3.01	150.0	± 9.6 %
		Y	4.31	77.47	22.45		150.0	
		Z	3.15	72.59	20.13		150.0	
10183-AAD	LTE-FDD (SC-FDMA, 1 RB, 15 MHz, 64-QAM)	X	2.77	69.34	18.18	3.01	150.0	± 9.6 %
		Y	3.28	71.69	18.90		150.0	
		Z	2.51	67.95	16.86		150.0	

10184-CAE	LTE-FDD (SC-FDMA, 1 RB, 3 MHz, QPSK)	X	2.59	67.89	18.74	3.01	150.0	± 9.6 %
		Y	2.85	69.35	19.17		150.0	
		Z	2.40	66.79	17.55		150.0	
10185-CAE	LTE-FDD (SC-FDMA, 1 RB, 3 MHz, 16-QAM)	X	3.48	74.22	21.51	3.01	150.0	± 9.6 %
		Y	4.33	77.57	22.50		150.0	
		Z	3.16	72.68	20.17		150.0	
10186-AAE	LTE-FDD (SC-FDMA, 1 RB, 3 MHz, 64-QAM)	X	2.79	69.40	18.21	3.01	150.0	± 9.6 %
		Y	3.30	71.77	18.93		150.0	
		Z	2.52	68.00	16.89		150.0	
10187-CAF	LTE-FDD (SC-FDMA, 1 RB, 1.4 MHz, QPSK)	X	2.60	67.99	18.84	3.01	150.0	± 9.6 %
		Y	2.87	69.44	19.26		150.0	
		Z	2.42	66.90	17.66		150.0	
10188-CAF	LTE-FDD (SC-FDMA, 1 RB, 1.4 MHz, 16-QAM)	X	3.60	74.96	21.95	3.01	150.0	± 9.6 %
		Y	4.53	78.50	22.98		150.0	
		Z	3.27	73.38	20.59		150.0	
10189-AAF	LTE-FDD (SC-FDMA, 1 RB, 1.4 MHz, 64-QAM)	X	2.85	69.84	18.51	3.01	150.0	± 9.6 %
		Y	3.39	72.31	19.27		150.0	
		Z	2.57	68.39	17.17		150.0	
10193-CAC	IEEE 802.11n (HT Greenfield, 6.5 Mbps, BPSK)	X	4.22	66.74	16.16	0.00	150.0	± 9.6 %
		Y	4.41	67.05	16.50		150.0	
		Z	4.10	66.98	15.94		150.0	
10194-CAC	IEEE 802.11n (HT Greenfield, 39 Mbps, 16-QAM)	X	4.36	66.95	16.30	0.00	150.0	± 9.6 %
		Y	4.56	67.31	16.63		150.0	
		Z	4.22	67.13	16.07		150.0	
10195-CAC	IEEE 802.11n (HT Greenfield, 65 Mbps, 64-QAM)	X	4.39	66.96	16.31	0.00	150.0	± 9.6 %
		Y	4.60	67.33	16.65		150.0	
		Z	4.24	67.10	16.06		150.0	
10196-CAC	IEEE 802.11n (HT Mixed, 6.5 Mbps, BPSK)	X	4.20	66.72	16.14	0.00	150.0	± 9.6 %
		Y	4.40	67.07	16.50		150.0	
		Z	4.08	66.92	15.90		150.0	
10197-CAC	IEEE 802.11n (HT Mixed, 39 Mbps, 16-QAM)	X	4.36	66.95	16.31	0.00	150.0	± 9.6 %
		Y	4.57	67.32	16.64		150.0	
		Z	4.22	67.12	16.07		150.0	
10198-CAC	IEEE 802.11n (HT Mixed, 65 Mbps, 64-QAM)	X	4.38	66.95	16.31	0.00	150.0	± 9.6 %
		Y	4.60	67.33	16.65		150.0	
		Z	4.23	67.09	16.06		150.0	
10219-CAC	IEEE 802.11n (HT Mixed, 7.2 Mbps, BPSK)	X	4.16	66.77	16.11	0.00	150.0	± 9.6 %
		Y	4.36	67.12	16.48		150.0	
		Z	4.04	67.00	15.89		150.0	
10220-CAC	IEEE 802.11n (HT Mixed, 43.3 Mbps, 16-QAM)	X	4.36	66.91	16.29	0.00	150.0	± 9.6 %
		Y	4.56	67.28	16.62		150.0	
		Z	4.21	67.08	16.06		150.0	
10221-CAC	IEEE 802.11n (HT Mixed, 72.2 Mbps, 64-QAM)	X	4.40	66.90	16.30	0.00	150.0	± 9.6 %
		Y	4.61	67.26	16.63		150.0	
		Z	4.25	67.06	16.06		150.0	
10222-CAC	IEEE 802.11n (HT Mixed, 15 Mbps, BPSK)	X	4.80	66.97	16.48	0.00	150.0	± 9.6 %
		Y	4.97	67.32	16.74		150.0	
		Z	4.65	66.99	16.22		150.0	

10223-CAC	IEEE 802.11n (HT Mixed, 90 Mbps, 16-QAM)	X	5.04	67.12	16.56	0.00	150.0	± 9.6 %
		Y	5.26	67.55	16.86		150.0	
		Z	4.85	67.05	16.24		150.0	
10224-CAC	IEEE 802.11n (HT Mixed, 150 Mbps, 64-QAM)	X	4.84	67.10	16.47	0.00	150.0	± 9.6 %
		Y	5.01	67.44	16.72		150.0	
		Z	4.69	67.14	16.22		150.0	
10225-CAB	UMTS-FDD (HSPA+)	X	2.48	66.09	14.60	0.00	150.0	± 9.6 %
		Y	2.74	67.15	15.74		150.0	
		Z	2.35	66.01	13.97		150.0	
10226-CAA	LTE-TDD (SC-FDMA, 1 RB, 1.4 MHz, 16-QAM)	X	14.63	100.77	30.27	6.02	65.0	± 9.6 %
		Y	13.50	95.53	27.22		65.0	
		Z	6.14	86.10	24.79		65.0	
10227-CAA	LTE-TDD (SC-FDMA, 1 RB, 1.4 MHz, 64-QAM)	X	14.28	98.83	28.99	6.02	65.0	± 9.6 %
		Y	12.07	92.18	25.50		65.0	
		Z	5.79	84.16	23.43		65.0	
10228-CAA	LTE-TDD (SC-FDMA, 1 RB, 1.4 MHz, QPSK)	X	7.72	92.84	29.85	6.02	65.0	± 9.6 %
		Y	8.40	91.70	28.18		65.0	
		Z	3.85	80.05	24.56		65.0	
10229-CAC	LTE-TDD (SC-FDMA, 1 RB, 3 MHz, 16-QAM)	X	13.19	98.68	29.54	6.02	65.0	± 9.6 %
		Y	12.39	93.91	26.64		65.0	
		Z	5.71	84.67	24.19		65.0	
10230-CAC	LTE-TDD (SC-FDMA, 1 RB, 3 MHz, 64-QAM)	X	12.76	96.74	28.27	6.02	65.0	± 9.6 %
		Y	11.09	90.72	24.97		65.0	
		Z	5.35	82.75	22.86		65.0	
10231-CAC	LTE-TDD (SC-FDMA, 1 RB, 3 MHz, QPSK)	X	7.26	91.45	29.29	6.02	65.0	± 9.6 %
		Y	7.93	90.49	27.69		65.0	
		Z	3.69	79.12	24.10		65.0	
10232-CAE	LTE-TDD (SC-FDMA, 1 RB, 5 MHz, 16-QAM)	X	13.17	98.65	29.53	6.02	65.0	± 9.6 %
		Y	12.38	93.90	26.63		65.0	
		Z	5.70	84.65	24.18		65.0	
10233-CAE	LTE-TDD (SC-FDMA, 1 RB, 5 MHz, 64-QAM)	X	12.71	96.69	28.26	6.02	65.0	± 9.6 %
		Y	11.07	90.70	24.96		65.0	
		Z	5.33	82.71	22.85		65.0	
10234-CAE	LTE-TDD (SC-FDMA, 1 RB, 5 MHz, QPSK)	X	6.94	90.39	28.79	6.02	65.0	± 9.6 %
		Y	7.56	89.42	27.20		65.0	
		Z	3.57	78.42	23.69		65.0	
10235-CAE	LTE-TDD (SC-FDMA, 1 RB, 10 MHz, 16-QAM)	X	13.20	98.72	29.56	6.02	65.0	± 9.6 %
		Y	12.41	93.95	26.65		65.0	
		Z	5.70	84.66	24.19		65.0	
10236-CAE	LTE-TDD (SC-FDMA, 1 RB, 10 MHz, 64-QAM)	X	12.89	96.88	28.31	6.02	65.0	± 9.6 %
		Y	11.19	90.84	25.00		65.0	
		Z	5.38	82.84	22.89		65.0	
10237-CAE	LTE-TDD (SC-FDMA, 1 RB, 10 MHz, QPSK)	X	7.27	91.51	29.31	6.02	65.0	± 9.6 %
		Y	7.94	90.56	27.72		65.0	
		Z	3.68	79.11	24.10		65.0	
10238-CAE	LTE-TDD (SC-FDMA, 1 RB, 15 MHz, 16-QAM)	X	13.14	98.63	29.53	6.02	65.0	± 9.6 %
		Y	12.35	93.88	26.62		65.0	
		Z	5.68	84.62	24.17		65.0	

10239-CAE	LTE-TDD (SC-FDMA, 1 RB, 15 MHz, 64-QAM)	X	12.66	96.64	28.25	6.02	65.0	± 9.6 %
		Y	11.03	90.67	24.95		65.0	
		Z	5.31	82.67	22.84		65.0	
10240-CAE	LTE-TDD (SC-FDMA, 1 RB, 15 MHz, QPSK)	X	7.25	91.49	29.30	6.02	65.0	± 9.6 %
		Y	7.92	90.52	27.70		65.0	
		Z	3.67	79.11	24.10		65.0	
10241-CAA	LTE-TDD (SC-FDMA, 50% RB, 1.4 MHz, 16-QAM)	X	8.07	83.66	26.60	6.98	65.0	± 9.6 %
		Y	8.23	82.37	25.42		65.0	
		Z	6.15	79.65	24.57		65.0	
10242-CAA	LTE-TDD (SC-FDMA, 50% RB, 1.4 MHz, 64-QAM)	X	7.13	81.10	25.49	6.98	65.0	± 9.6 %
		Y	7.19	79.66	24.27		65.0	
		Z	5.16	76.21	23.08		65.0	
10243-CAA	LTE-TDD (SC-FDMA, 50% RB, 1.4 MHz, QPSK)	X	5.70	77.08	24.75	6.98	65.0	± 9.6 %
		Y	5.79	76.18	23.77		65.0	
		Z	4.35	72.84	22.46		65.0	
10244-CAC	LTE-TDD (SC-FDMA, 50% RB, 3 MHz, 16-QAM)	X	3.90	69.73	14.28	3.98	65.0	± 9.6 %
		Y	4.14	69.75	14.43		65.0	
		Z	2.32	64.19	10.29		65.0	
10245-CAC	LTE-TDD (SC-FDMA, 50% RB, 3 MHz, 64-QAM)	X	3.76	68.99	13.88	3.98	65.0	± 9.6 %
		Y	4.05	69.22	14.14		65.0	
		Z	2.29	63.87	10.07		65.0	
10246-CAC	LTE-TDD (SC-FDMA, 50% RB, 3 MHz, QPSK)	X	3.54	71.57	15.31	3.98	65.0	± 9.6 %
		Y	4.20	73.49	16.58		65.0	
		Z	2.19	66.68	12.21		65.0	
10247-CAE	LTE-TDD (SC-FDMA, 50% RB, 5 MHz, 16-QAM)	X	3.93	70.34	15.60	3.98	65.0	± 9.6 %
		Y	4.37	71.41	16.50		65.0	
		Z	2.89	67.23	13.31		65.0	
10248-CAE	LTE-TDD (SC-FDMA, 50% RB, 5 MHz, 64-QAM)	X	3.84	69.61	15.25	3.98	65.0	± 9.6 %
		Y	4.32	70.82	16.23		65.0	
		Z	2.83	66.58	12.98		65.0	
10249-CAE	LTE-TDD (SC-FDMA, 50% RB, 5 MHz, QPSK)	X	6.16	80.46	20.36	3.98	65.0	± 9.6 %
		Y	6.18	79.81	20.33		65.0	
		Z	3.97	75.17	17.64		65.0	
10250-CAE	LTE-TDD (SC-FDMA, 50% RB, 10 MHz, 16-QAM)	X	5.62	76.39	20.75	3.98	65.0	± 9.6 %
		Y	5.74	75.93	20.59		65.0	
		Z	4.58	74.22	19.36		65.0	
10251-CAE	LTE-TDD (SC-FDMA, 50% RB, 10 MHz, 64-QAM)	X	5.03	73.18	18.92	3.98	65.0	± 9.6 %
		Y	5.31	73.34	19.08		65.0	
		Z	4.06	70.93	17.39		65.0	
10252-CAE	LTE-TDD (SC-FDMA, 50% RB, 10 MHz, QPSK)	X	7.24	83.33	23.20	3.98	65.0	± 9.6 %
		Y	6.94	81.44	22.37		65.0	
		Z	5.41	79.92	21.58		65.0	
10253-CAE	LTE-TDD (SC-FDMA, 50% RB, 15 MHz, 16-QAM)	X	5.26	72.84	19.45	3.98	65.0	± 9.6 %
		Y	5.49	72.84	19.41		65.0	
		Z	4.40	71.02	18.22		65.0	
10254-CAE	LTE-TDD (SC-FDMA, 50% RB, 15 MHz, 64-QAM)	X	5.65	74.03	20.30	3.98	65.0	± 9.6 %
		Y	5.87	73.92	20.21		65.0	
		Z	4.76	72.26	19.12		65.0	

10255-CAE	LTE-TDD (SC-FDMA, 50% RB, 15 MHz, QPSK)	X	6.29	78.80	21.96	3.98	65.0	± 9.6 %
		Y	6.30	77.79	21.37		65.0	
		Z	5.06	76.49	20.76		65.0	
10256-CAA	LTE-TDD (SC-FDMA, 100% RB, 1.4 MHz, 16-QAM)	X	2.61	64.47	10.42	3.98	65.0	± 9.6 %
		Y	2.96	65.33	11.13		65.0	
		Z	1.66	61.09	7.28		65.0	
10257-CAA	LTE-TDD (SC-FDMA, 100% RB, 1.4 MHz, 64-QAM)	X	2.56	63.97	10.05	3.98	65.0	± 9.6 %
		Y	2.92	64.89	10.82		65.0	
		Z	1.65	60.87	7.05		65.0	
10258-CAA	LTE-TDD (SC-FDMA, 100% RB, 1.4 MHz, QPSK)	X	2.21	64.99	10.99	3.98	65.0	± 9.6 %
		Y	2.77	67.33	12.75		65.0	
		Z	1.46	61.94	8.37		65.0	
10259-CAC	LTE-TDD (SC-FDMA, 100% RB, 3 MHz, 16-QAM)	X	4.60	72.78	17.56	3.98	65.0	± 9.6 %
		Y	4.92	73.23	18.04		65.0	
		Z	3.51	69.91	15.55		65.0	
10260-CAC	LTE-TDD (SC-FDMA, 100% RB, 3 MHz, 64-QAM)	X	4.59	72.39	17.37	3.98	65.0	± 9.6 %
		Y	4.92	72.90	17.90		65.0	
		Z	3.52	69.59	15.38		65.0	
10261-CAC	LTE-TDD (SC-FDMA, 100% RB, 3 MHz, QPSK)	X	6.31	80.89	21.20	3.98	65.0	± 9.6 %
		Y	6.19	79.71	20.87		65.0	
		Z	4.43	76.66	19.01		65.0	
10262-CAE	LTE-TDD (SC-FDMA, 100% RB, 5 MHz, 16-QAM)	X	5.59	76.27	20.67	3.98	65.0	± 9.6 %
		Y	5.72	75.84	20.52		65.0	
		Z	4.55	74.08	19.27		65.0	
10263-CAE	LTE-TDD (SC-FDMA, 100% RB, 5 MHz, 64-QAM)	X	5.02	73.16	18.92	3.98	65.0	± 9.6 %
		Y	5.30	73.32	19.07		65.0	
		Z	4.06	70.92	17.39		65.0	
10264-CAE	LTE-TDD (SC-FDMA, 100% RB, 5 MHz, QPSK)	X	7.12	83.00	23.05	3.98	65.0	± 9.6 %
		Y	6.85	81.18	22.25		65.0	
		Z	5.32	79.60	21.43		65.0	
10265-CAE	LTE-TDD (SC-FDMA, 100% RB, 10 MHz, 16-QAM)	X	5.33	73.24	19.78	3.98	65.0	± 9.6 %
		Y	5.58	73.28	19.69		65.0	
		Z	4.46	71.34	18.58		65.0	
10266-CAE	LTE-TDD (SC-FDMA, 100% RB, 10 MHz, 64-QAM)	X	5.79	74.63	20.77	3.98	65.0	± 9.6 %
		Y	6.01	74.49	20.59		65.0	
		Z	4.89	72.85	19.66		65.0	
10267-CAE	LTE-TDD (SC-FDMA, 100% RB, 10 MHz, QPSK)	X	6.58	79.40	22.08	3.98	65.0	± 9.6 %
		Y	6.57	78.32	21.41		65.0	
		Z	5.30	77.16	20.98		65.0	
10268-CAE	LTE-TDD (SC-FDMA, 100% RB, 15 MHz, 16-QAM)	X	5.96	73.22	20.37	3.98	65.0	± 9.6 %
		Y	6.21	73.29	20.22		65.0	
		Z	5.14	71.69	19.40		65.0	
10269-CAE	LTE-TDD (SC-FDMA, 100% RB, 15 MHz, 64-QAM)	X	5.96	72.84	20.22	3.98	65.0	± 9.6 %
		Y	6.20	72.91	20.10		65.0	
		Z	5.18	71.41	19.28		65.0	
10270-CAE	LTE-TDD (SC-FDMA, 100% RB, 15 MHz, QPSK)	X	6.23	76.00	20.96	3.98	65.0	± 9.6 %
		Y	6.35	75.47	20.49		65.0	
		Z	5.32	74.55	20.15		65.0	

10274-CAB	UMTS-FDD (HSUPA, Subtest 5, 3GPP Rel8.10)	X	2.34	66.81	14.69	0.00	150.0	± 9.6 %
		Y	2.62	68.03	15.92		150.0	
		Z	2.21	66.68	14.08		150.0	
10275-CAB	UMTS-FDD (HSUPA, Subtest 5, 3GPP Rel8.4)	X	1.44	68.53	15.18	0.00	150.0	± 9.6 %
		Y	1.86	72.07	17.62		150.0	
		Z	1.32	67.78	14.48		150.0	
10277-CAA	PHS (QPSK)	X	2.18	61.09	6.72	9.03	50.0	± 9.6 %
		Y	2.24	61.20	6.85		50.0	
		Z	1.56	59.15	4.54		50.0	
10278-CAA	PHS (QPSK, BW 884MHz, Rolloff 0.5)	X	3.31	65.77	11.35	9.03	50.0	± 9.6 %
		Y	3.43	66.36	11.86		50.0	
		Z	2.47	63.10	8.79		50.0	
10279-CAA	PHS (QPSK, BW 884MHz, Rolloff 0.38)	X	3.36	65.91	11.47	9.03	50.0	± 9.6 %
		Y	3.51	66.55	12.01		50.0	
		Z	2.51	63.19	8.90		50.0	
10290-AAB	CDMA2000, RC1, SO55, Full Rate	X	0.55	60.70	6.89	0.00	150.0	± 9.6 %
		Y	1.57	71.17	13.79		150.0	
		Z	0.43	60.00	5.78		150.0	
10291-AAB	CDMA2000, RC3, SO55, Full Rate	X	0.35	60.00	5.89	0.00	150.0	± 9.6 %
		Y	0.88	68.42	12.36		150.0	
		Z	0.31	60.00	5.29		150.0	
10292-AAB	CDMA2000, RC3, SO32, Full Rate	X	0.34	60.13	6.21	0.00	150.0	± 9.6 %
		Y	32.57	110.87	25.46		150.0	
		Z	0.30	60.00	5.55		150.0	
10293-AAB	CDMA2000, RC3, SO3, Full Rate	X	0.47	62.79	8.16	0.00	150.0	± 9.6 %
		Y	100.00	129.73	30.90		150.0	
		Z	0.34	60.84	6.50		150.0	
10295-AAB	CDMA2000, RC1, SO3, 1/8th Rate 25 fr.	X	21.80	94.03	24.61	9.03	50.0	± 9.6 %
		Y	10.29	83.42	21.60		50.0	
		Z	18.76	90.39	22.23		50.0	
10297-AAD	LTE-FDD (SC-FDMA, 50% RB, 20 MHz, QPSK)	X	2.48	69.89	16.70	0.00	150.0	± 9.6 %
		Y	2.90	71.99	18.00		150.0	
		Z	2.30	69.40	16.27		150.0	
10298-AAD	LTE-FDD (SC-FDMA, 50% RB, 3 MHz, QPSK)	X	0.80	62.04	8.74	0.00	150.0	± 9.6 %
		Y	1.54	69.24	13.91		150.0	
		Z	0.63	60.57	7.13		150.0	
10299-AAD	LTE-FDD (SC-FDMA, 50% RB, 3 MHz, 16-QAM)	X	1.28	62.79	8.90	0.00	150.0	± 9.6 %
		Y	1.89	66.17	11.32		150.0	
		Z	0.83	59.79	5.92		150.0	
10300-AAD	LTE-FDD (SC-FDMA, 50% RB, 3 MHz, 64-QAM)	X	1.04	60.46	6.87	0.00	150.0	± 9.6 %
		Y	1.40	62.36	8.64		150.0	
		Z	0.71	58.57	4.53		150.0	
10301-AAA	IEEE 802.16e WiMAX (29:18, 5ms, 10MHz, QPSK, PUSC)	X	4.74	67.13	17.88	4.17	50.0	± 9.6 %
		Y	4.69	66.45	17.92		50.0	
		Z	4.19	65.82	16.84		50.0	
10302-AAA	IEEE 802.16e WiMAX (29:18, 5ms, 10MHz, QPSK, PUSC, 3 CTRL symbols)	X	5.21	67.89	18.77	4.96	50.0	± 9.6 %
		Y	5.09	66.62	18.38		50.0	
		Z	4.70	66.71	17.77		50.0	

10303-AAA	IEEE 802.16e WiMAX (31:15, 5ms, 10MHz, 64QAM, PUSC)	X	5.02	67.85	18.70	4.96	50.0	± 9.6 %
		Y	4.86	66.33	18.21		50.0	
		Z	4.51	66.60	17.64		50.0	
10304-AAA	IEEE 802.16e WiMAX (29:18, 5ms, 10MHz, 64QAM, PUSC)	X	4.62	66.40	17.42	4.17	50.0	± 9.6 %
		Y	4.67	66.23	17.75		50.0	
		Z	4.22	65.74	16.72		50.0	
10305-AAA	IEEE 802.16e WiMAX (31:15, 10ms, 10MHz, 64QAM, PUSC, 15 symbols)	X	5.39	72.72	20.66	6.02	35.0	± 9.6 %
		Y	4.79	70.33	20.43		35.0	
		Z	4.15	68.57	18.14		35.0	
10306-AAA	IEEE 802.16e WiMAX (29:18, 10ms, 10MHz, 64QAM, PUSC, 18 symbols)	X	5.13	69.90	19.93	6.02	35.0	± 9.6 %
		Y	4.84	68.23	19.72		35.0	
		Z	4.35	67.45	18.21		35.0	
10307-AAA	IEEE 802.16e WiMAX (29:18, 10ms, 10MHz, QPSK, PUSC, 18 symbols)	X	5.08	70.20	19.92	6.02	35.0	± 9.6 %
		Y	4.77	68.50	19.72		35.0	
		Z	4.25	67.50	18.09		35.0	
10308-AAA	IEEE 802.16e WiMAX (29:18, 10ms, 10MHz, 16QAM, PUSC)	X	5.12	70.64	20.16	6.02	35.0	± 9.6 %
		Y	4.77	68.84	19.93		35.0	
		Z	4.25	67.77	18.27		35.0	
10309-AAA	IEEE 802.16e WiMAX (29:18, 10ms, 10MHz, 16QAM, AMC 2x3, 18 symbols)	X	5.14	69.95	20.02	6.02	35.0	± 9.6 %
		Y	4.87	68.35	19.83		35.0	
		Z	4.35	67.48	18.29		35.0	
10310-AAA	IEEE 802.16e WiMAX (29:18, 10ms, 10MHz, QPSK, AMC 2x3, 18 symbols)	X	5.13	70.13	19.99	6.02	35.0	± 9.6 %
		Y	4.81	68.40	19.75		35.0	
		Z	4.32	67.59	18.24		35.0	
10311-AAD	LTE-FDD (SC-FDMA, 100% RB, 15 MHz, QPSK)	X	2.83	68.90	16.32	0.00	150.0	± 9.6 %
		Y	3.26	70.86	17.46		150.0	
		Z	2.65	68.52	15.97		150.0	
10313-AAA	iDEN 1:3	X	3.36	72.20	15.56	6.99	70.0	± 9.6 %
		Y	3.23	71.05	14.93		70.0	
		Z	2.47	70.33	14.60		70.0	
10314-AAA	iDEN 1:6	X	7.46	85.19	22.96	10.00	30.0	± 9.6 %
		Y	5.21	79.23	20.77		30.0	
		Z	8.81	89.37	24.10		30.0	
10315-AAB	IEEE 802.11b WiFi 2.4 GHz (DSSS, 1 Mbps, 96pc duty cycle)	X	0.97	64.18	15.35	0.17	150.0	± 9.6 %
		Y	1.09	65.56	16.62		150.0	
		Z	0.95	63.77	14.73		150.0	
10316-AAB	IEEE 802.11g WiFi 2.4 GHz (ERP-OFDM, 6 Mbps, 96pc duty cycle)	X	4.27	66.73	16.30	0.17	150.0	± 9.6 %
		Y	4.44	66.97	16.55		150.0	
		Z	4.11	66.81	16.00		150.0	
10317-AAC	IEEE 802.11a WiFi 5 GHz (OFDM, 6 Mbps, 96pc duty cycle)	X	4.27	66.73	16.30	0.17	150.0	± 9.6 %
		Y	4.44	66.97	16.55		150.0	
		Z	4.11	66.81	16.00		150.0	
10400-AAD	IEEE 802.11ac WiFi (20MHz, 64-QAM, 99pc duty cycle)	X	4.31	66.93	16.26	0.00	150.0	± 9.6 %
		Y	4.53	67.33	16.61		150.0	
		Z	4.13	66.97	15.96		150.0	
10401-AAD	IEEE 802.11ac WiFi (40MHz, 64-QAM, 99pc duty cycle)	X	4.97	66.63	16.27	0.00	150.0	± 9.6 %
		Y	5.22	67.18	16.63		150.0	
		Z	4.86	66.85	16.09		150.0	

10402-AAD	IEEE 802.11ac WiFi (80MHz, 64-QAM, 99pc duty cycle)	X	5.35	67.25	16.49	0.00	150.0	± 9.6 %
		Y	5.52	67.59	16.72		150.0	
		Z	5.21	67.33	16.26		150.0	
10403-AAB	CDMA2000 (1xEV-DO, Rev. 0)	X	0.55	60.70	6.89	0.00	115.0	± 9.6 %
		Y	1.57	71.17	13.79		115.0	
		Z	0.43	60.00	5.78		115.0	
10404-AAB	CDMA2000 (1xEV-DO, Rev. A)	X	0.55	60.70	6.89	0.00	115.0	± 9.6 %
		Y	1.57	71.17	13.79		115.0	
		Z	0.43	60.00	5.78		115.0	
10406-AAB	CDMA2000, RC3, SO32, SCH0, Full Rate	X	100.00	121.47	29.36	0.00	100.0	± 9.6 %
		Y	100.00	116.93	27.68		100.0	
		Z	100.00	111.07	24.20		100.0	
10410-AAE	LTE-TDD (SC-FDMA, 1 RB, 10 MHz, QPSK, UL Subframe=2,3,4,7,8,9, Subframe Conf=4)	X	100.00	127.60	32.19	3.23	80.0	± 9.6 %
		Y	47.53	108.69	25.78		80.0	
		Z	7.51	90.42	21.34		80.0	
10415-AAA	IEEE 802.11b WiFi 2.4 GHz (DSSS, 1 Mbps, 99pc duty cycle)	X	0.89	63.20	14.69	0.00	150.0	± 9.6 %
		Y	1.01	64.66	16.11		150.0	
		Z	0.90	63.14	14.25		150.0	
10416-AAA	IEEE 802.11g WiFi 2.4 GHz (ERP-OFDM, 6 Mbps, 99pc duty cycle)	X	4.21	66.70	16.23	0.00	150.0	± 9.6 %
		Y	4.41	67.06	16.58		150.0	
		Z	4.08	66.88	15.99		150.0	
10417-AAB	IEEE 802.11a/h WiFi 5 GHz (OFDM, 6 Mbps, 99pc duty cycle)	X	4.21	66.70	16.23	0.00	150.0	± 9.6 %
		Y	4.41	67.06	16.58		150.0	
		Z	4.08	66.88	15.99		150.0	
10418-AAA	IEEE 802.11g WiFi 2.4 GHz (DSSS-OFDM, 6 Mbps, 99pc duty cycle, Long preamble)	X	4.21	66.94	16.30	0.00	150.0	± 9.6 %
		Y	4.41	67.28	16.64		150.0	
		Z	4.08	67.11	16.07		150.0	
10419-AAA	IEEE 802.11g WiFi 2.4 GHz (DSSS-OFDM, 6 Mbps, 99pc duty cycle, Short preamble)	X	4.23	66.86	16.28	0.00	150.0	± 9.6 %
		Y	4.43	67.20	16.62		150.0	
		Z	4.09	67.03	16.04		150.0	
10422-AAB	IEEE 802.11n (HT Greenfield, 7.2 Mbps, BPSK)	X	4.33	66.82	16.29	0.00	150.0	± 9.6 %
		Y	4.53	67.16	16.62		150.0	
		Z	4.19	66.99	16.05		150.0	
10423-AAB	IEEE 802.11n (HT Greenfield, 43.3 Mbps, 16-QAM)	X	4.45	67.07	16.37	0.00	150.0	± 9.6 %
		Y	4.67	67.43	16.71		150.0	
		Z	4.29	67.21	16.12		150.0	
10424-AAB	IEEE 802.11n (HT Greenfield, 72.2 Mbps, 64-QAM)	X	4.38	67.01	16.35	0.00	150.0	± 9.6 %
		Y	4.60	67.39	16.69		150.0	
		Z	4.22	67.14	16.10		150.0	
10425-AAB	IEEE 802.11n (HT Greenfield, 15 Mbps, BPSK)	X	5.04	67.22	16.60	0.00	150.0	± 9.6 %
		Y	5.22	67.55	16.84		150.0	
		Z	4.84	67.12	16.26		150.0	
10426-AAB	IEEE 802.11n (HT Greenfield, 90 Mbps, 16-QAM)	X	5.08	67.41	16.68	0.00	150.0	± 9.6 %
		Y	5.25	67.68	16.90		150.0	
		Z	4.88	67.29	16.34		150.0	

10427-AAB	IEEE 802.11n (HT Greenfield, 150 Mbps, 64-QAM)	X	5.02	67.08	16.52	0.00	150.0	± 9.6 %
		Y	5.21	67.45	16.78		150.0	
		Z	4.85	67.10	16.25		150.0	
10430-AAC	LTE-FDD (OFDMA, 5 MHz, E-TM 3.1)	X	4.34	73.60	18.73	0.00	150.0	± 9.6 %
		Y	4.67	74.31	19.65		150.0	
		Z	4.56	75.21	18.83		150.0	
10431-AAC	LTE-FDD (OFDMA, 10 MHz, E-TM 3.1)	X	3.81	67.34	16.02	0.00	150.0	± 9.6 %
		Y	4.07	67.85	16.58		150.0	
		Z	3.64	67.45	15.66		150.0	
10432-AAC	LTE-FDD (OFDMA, 15 MHz, E-TM 3.1)	X	4.14	67.15	16.26	0.00	150.0	± 9.6 %
		Y	4.37	67.55	16.66		150.0	
		Z	3.98	67.29	15.98		150.0	
10433-AAC	LTE-FDD (OFDMA, 20 MHz, E-TM 3.1)	X	4.40	67.05	16.37	0.00	150.0	± 9.6 %
		Y	4.61	67.43	16.71		150.0	
		Z	4.25	67.19	16.13		150.0	
10434-AAA	W-CDMA (BS Test Model 1, 64 DPCH)	X	4.41	74.13	18.22	0.00	150.0	± 9.6 %
		Y	5.02	75.91	19.74		150.0	
		Z	4.48	75.04	17.90		150.0	
10435-AAE	LTE-TDD (SC-FDMA, 1 RB, 20 MHz, QPSK, UL Subframe=2,3,4,7,8,9)	X	100.00	127.28	32.04	3.23	80.0	± 9.6 %
		Y	37.77	105.68	25.00		80.0	
		Z	6.65	88.77	20.79		80.0	
10447-AAC	LTE-FDD (OFDMA, 5 MHz, E-TM 3.1, Clipping 44%)	X	2.99	66.80	14.43	0.00	150.0	± 9.6 %
		Y	3.36	68.04	15.68		150.0	
		Z	2.75	66.44	13.65		150.0	
10448-AAC	LTE-FDD (OFDMA, 10 MHz, E-TM 3.1, Clipping 44%)	X	3.68	67.14	15.90	0.00	150.0	± 9.6 %
		Y	3.93	67.65	16.46		150.0	
		Z	3.53	67.26	15.55		150.0	
10449-AAC	LTE-FDD (OFDMA, 15 MHz, E-TM 3.1, Clipping 44%)	X	3.99	66.98	16.16	0.00	150.0	± 9.6 %
		Y	4.20	67.40	16.58		150.0	
		Z	3.85	67.13	15.89		150.0	
10450-AAC	LTE-FDD (OFDMA, 20 MHz, E-TM 3.1, Clipping 44%)	X	4.21	66.83	16.23	0.00	150.0	± 9.6 %
		Y	4.41	67.22	16.58		150.0	
		Z	4.07	66.98	15.98		150.0	
10451-AAA	W-CDMA (BS Test Model 1, 64 DPCH, Clipping 44%)	X	2.72	66.13	13.34	0.00	150.0	± 9.6 %
		Y	3.20	67.97	15.02		150.0	
		Z	2.40	65.33	12.26		150.0	
10456-AAB	IEEE 802.11ac WiFi (160MHz, 64-QAM, 99pc duty cycle)	X	6.02	67.79	16.78	0.00	150.0	± 9.6 %
		Y	6.18	68.16	17.02		150.0	
		Z	6.18	68.79	17.02		150.0	
10457-AAA	UMTS-FDD (DC-HSDPA)	X	3.59	65.49	15.98	0.00	150.0	± 9.6 %
		Y	3.73	65.74	16.31		150.0	
		Z	3.53	65.80	15.77		150.0	
10458-AAA	CDMA2000 (1xEV-DO, Rev. B, 2 carriers)	X	3.34	70.08	15.60	0.00	150.0	± 9.6 %
		Y	4.35	74.00	18.36		150.0	
		Z	2.73	67.81	13.63		150.0	
10459-AAA	CDMA2000 (1xEV-DO, Rev. B, 3 carriers)	X	4.80	69.70	17.95	0.00	150.0	± 9.6 %
		Y	5.15	70.28	18.81		150.0	
		Z	4.66	69.99	17.32		150.0	

10460-AAA	UMTS-FDD (WCDMA, AMR)	X	0.87	70.93	16.52	0.00	150.0	± 9.6 %
		Y	1.46	79.26	21.40		150.0	
		Z	0.76	68.76	15.32		150.0	
10461-AAA	LTE-TDD (SC-FDMA, 1 RB, 1.4 MHz, QPSK, UL Subframe=2,3,4,7,8,9)	X	100.00	133.64	34.98	3.29	80.0	± 9.6 %
		Y	100.00	121.27	29.54		80.0	
		Z	11.51	98.13	24.42		80.0	
10462-AAA	LTE-TDD (SC-FDMA, 1 RB, 1.4 MHz, 16-QAM, UL Subframe=2,3,4,7,8,9)	X	1.56	66.37	11.18	3.23	80.0	± 9.6 %
		Y	0.87	60.00	7.45		80.0	
		Z	0.67	60.00	6.91		80.0	
10463-AAA	LTE-TDD (SC-FDMA, 1 RB, 1.4 MHz, 64-QAM, UL Subframe=2,3,4,7,8,9)	X	0.80	60.00	7.65	3.23	80.0	± 9.6 %
		Y	0.89	60.00	6.91		80.0	
		Z	0.69	60.00	6.22		80.0	
10464-AAB	LTE-TDD (SC-FDMA, 1 RB, 3 MHz, QPSK, UL Subframe=2,3,4,7,8,9)	X	100.00	130.01	33.13	3.23	80.0	± 9.6 %
		Y	30.66	103.77	24.63		80.0	
		Z	3.86	82.95	19.21		80.0	
10465-AAB	LTE-TDD (SC-FDMA, 1 RB, 3 MHz, 16-QAM, UL Subframe=2,3,4,7,8,9)	X	1.24	64.19	10.21	3.23	80.0	± 9.6 %
		Y	0.87	60.00	7.39		80.0	
		Z	0.67	60.00	6.85		80.0	
10466-AAB	LTE-TDD (SC-FDMA, 1 RB, 3 MHz, 64-QAM, UL Subframe=2,3,4,7,8,9)	X	0.80	60.00	7.60	3.23	80.0	± 9.6 %
		Y	0.90	60.00	6.88		80.0	
		Z	0.69	60.00	6.19		80.0	
10467-AAD	LTE-TDD (SC-FDMA, 1 RB, 5 MHz, QPSK, UL Subframe=2,3,4,7,8,9)	X	100.00	130.52	33.35	3.23	80.0	± 9.6 %
		Y	47.97	109.22	25.94		80.0	
		Z	4.78	85.69	20.10		80.0	
10468-AAD	LTE-TDD (SC-FDMA, 1 RB, 5 MHz, 16-QAM, UL Subframe=2,3,4,7,8,9)	X	1.33	64.86	10.52	3.23	80.0	± 9.6 %
		Y	0.87	60.00	7.41		80.0	
		Z	0.67	60.00	6.88		80.0	
10469-AAD	LTE-TDD (SC-FDMA, 1 RB, 5 MHz, 64-QAM, UL Subframe=2,3,4,7,8,9)	X	0.80	60.00	7.61	3.23	80.0	± 9.6 %
		Y	0.89	60.00	6.87		80.0	
		Z	0.69	60.00	6.19		80.0	
10470-AAD	LTE-TDD (SC-FDMA, 1 RB, 10 MHz, QPSK, UL Subframe=2,3,4,7,8,9)	X	100.00	130.55	33.36	3.23	80.0	± 9.6 %
		Y	49.35	109.54	26.00		80.0	
		Z	4.82	85.81	20.13		80.0	
10471-AAD	LTE-TDD (SC-FDMA, 1 RB, 10 MHz, 16-QAM, UL Subframe=2,3,4,7,8,9)	X	1.31	64.74	10.46	3.23	80.0	± 9.6 %
		Y	0.87	60.00	7.39		80.0	
		Z	0.66	60.00	6.86		80.0	
10472-AAD	LTE-TDD (SC-FDMA, 1 RB, 10 MHz, 64-QAM, UL Subframe=2,3,4,7,8,9)	X	0.80	60.00	7.59	3.23	80.0	± 9.6 %
		Y	0.89	60.00	6.86		80.0	
		Z	0.69	60.00	6.17		80.0	
10473-AAD	LTE-TDD (SC-FDMA, 1 RB, 15 MHz, QPSK, UL Subframe=2,3,4,7,8,9)	X	100.00	130.51	33.34	3.23	80.0	± 9.6 %
		Y	48.03	109.20	25.91		80.0	
		Z	4.74	85.60	20.06		80.0	
10474-AAD	LTE-TDD (SC-FDMA, 1 RB, 15 MHz, 16-QAM, UL Subframe=2,3,4,7,8,9)	X	1.30	64.69	10.43	3.23	80.0	± 9.6 %
		Y	0.87	60.00	7.39		80.0	
		Z	0.66	60.00	6.86		80.0	
10475-AAD	LTE-TDD (SC-FDMA, 1 RB, 15 MHz, 64-QAM, UL Subframe=2,3,4,7,8,9)	X	0.80	60.00	7.59	3.23	80.0	± 9.6 %
		Y	0.89	60.00	6.86		80.0	
		Z	0.69	60.00	6.17		80.0	

10477-AAE	LTE-TDD (SC-FDMA, 1 RB, 20 MHz, 16-QAM, UL Subframe=2,3,4,7,8,9)	X	1.23	64.18	10.18	3.23	80.0	± 9.6 %
		Y	0.87	60.00	7.37		80.0	
		Z	0.66	60.00	6.83		80.0	
10478-AAE	LTE-TDD (SC-FDMA, 1 RB, 20 MHz, 64-QAM, UL Subframe=2,3,4,7,8,9)	X	0.80	60.00	7.58	3.23	80.0	± 9.6 %
		Y	0.89	60.00	6.85		80.0	
		Z	0.69	60.00	6.16		80.0	
10479-AAA	LTE-TDD (SC-FDMA, 50% RB, 1.4 MHz, QPSK, UL Subframe=2,3,4,7,8,9)	X	100.00	126.80	33.24	3.23	80.0	± 9.6 %
		Y	16.83	96.78	24.93		80.0	
		Z	17.83	99.90	25.23		80.0	
10480-AAA	LTE-TDD (SC-FDMA, 50% RB, 1.4 MHz, 16-QAM, UL Subframe=2,3,4,7,8,9)	X	100.00	110.98	25.88	3.23	80.0	± 9.6 %
		Y	4.24	73.22	15.24		80.0	
		Z	1.74	65.87	11.40		80.0	
10481-AAA	LTE-TDD (SC-FDMA, 50% RB, 1.4 MHz, 64-QAM, UL Subframe=2,3,4,7,8,9)	X	16.05	88.37	19.67	3.23	80.0	± 9.6 %
		Y	2.80	68.08	12.86		80.0	
		Z	1.19	61.90	9.13		80.0	
10482-AAB	LTE-TDD (SC-FDMA, 50% RB, 3 MHz, QPSK, UL Subframe=2,3,4,7,8,9)	X	1.57	64.75	11.63	2.23	80.0	± 9.6 %
		Y	2.36	69.10	14.35		80.0	
		Z	0.89	60.11	8.42		80.0	
10483-AAB	LTE-TDD (SC-FDMA, 50% RB, 3 MHz, 16-QAM, UL Subframe=2,3,4,7,8,9)	X	2.03	64.54	11.14	2.23	80.0	± 9.6 %
		Y	2.19	64.68	11.58		80.0	
		Z	1.14	60.00	7.47		80.0	
10484-AAB	LTE-TDD (SC-FDMA, 50% RB, 3 MHz, 64-QAM, UL Subframe=2,3,4,7,8,9)	X	1.90	63.58	10.68	2.23	80.0	± 9.6 %
		Y	2.12	64.08	11.29		80.0	
		Z	1.17	60.00	7.46		80.0	
10485-AAD	LTE-TDD (SC-FDMA, 50% RB, 5 MHz, QPSK, UL Subframe=2,3,4,7,8,9)	X	3.45	74.98	17.66	2.23	80.0	± 9.6 %
		Y	3.58	75.04	18.20		80.0	
		Z	1.95	68.57	14.43		80.0	
10486-AAD	LTE-TDD (SC-FDMA, 50% RB, 5 MHz, 16-QAM, UL Subframe=2,3,4,7,8,9)	X	2.25	65.84	12.95	2.23	80.0	± 9.6 %
		Y	2.80	68.12	14.63		80.0	
		Z	1.49	62.13	10.33		80.0	
10487-AAD	LTE-TDD (SC-FDMA, 50% RB, 5 MHz, 64-QAM, UL Subframe=2,3,4,7,8,9)	X	2.22	65.29	12.67	2.23	80.0	± 9.6 %
		Y	2.76	67.57	14.36		80.0	
		Z	1.49	61.80	10.12		80.0	
10488-AAD	LTE-TDD (SC-FDMA, 50% RB, 10 MHz, QPSK, UL Subframe=2,3,4,7,8,9)	X	3.71	75.02	19.43	2.23	80.0	± 9.6 %
		Y	3.72	74.14	19.13		80.0	
		Z	2.67	71.23	17.54		80.0	
10489-AAD	LTE-TDD (SC-FDMA, 50% RB, 10 MHz, 16-QAM, UL Subframe=2,3,4,7,8,9)	X	3.33	70.04	17.15	2.23	80.0	± 9.6 %
		Y	3.44	69.76	17.22		80.0	
		Z	2.72	68.09	15.79		80.0	
10490-AAD	LTE-TDD (SC-FDMA, 50% RB, 10 MHz, 64-QAM, UL Subframe=2,3,4,7,8,9)	X	3.38	69.72	17.01	2.23	80.0	± 9.6 %
		Y	3.50	69.51	17.12		80.0	
		Z	2.77	67.83	15.66		80.0	
10491-AAD	LTE-TDD (SC-FDMA, 50% RB, 15 MHz, QPSK, UL Subframe=2,3,4,7,8,9)	X	3.67	72.22	18.70	2.23	80.0	± 9.6 %
		Y	3.79	71.87	18.50		80.0	
		Z	2.91	69.73	17.36		80.0	
10492-AAD	LTE-TDD (SC-FDMA, 50% RB, 15 MHz, 16-QAM, UL Subframe=2,3,4,7,8,9)	X	3.59	68.89	17.30	2.23	80.0	± 9.6 %
		Y	3.72	68.74	17.28		80.0	
		Z	3.08	67.54	16.30		80.0	

10493-AAD	LTE-TDD (SC-FDMA, 50% RB, 15 MHz, 64-QAM, UL Subframe=2,3,4,7,8,9)	X	3.63	68.68	17.20	2.23	80.0	± 9.6 %
		Y	3.77	68.57	17.21		80.0	
		Z	3.12	67.39	16.21		80.0	
10494-AAE	LTE-TDD (SC-FDMA, 50% RB, 20 MHz, QPSK, UL Subframe=2,3,4,7,8,9)	X	4.02	73.80	19.26	2.23	80.0	± 9.6 %
		Y	4.14	73.43	19.01		80.0	
		Z	3.12	70.94	17.86		80.0	
10495-AAE	LTE-TDD (SC-FDMA, 50% RB, 20 MHz, 16-QAM, UL Subframe=2,3,4,7,8,9)	X	3.62	69.18	17.57	2.23	80.0	± 9.6 %
		Y	3.76	69.07	17.51		80.0	
		Z	3.11	67.77	16.60		80.0	
10496-AAE	LTE-TDD (SC-FDMA, 50% RB, 20 MHz, 64-QAM, UL Subframe=2,3,4,7,8,9)	X	3.69	68.89	17.47	2.23	80.0	± 9.6 %
		Y	3.82	68.78	17.42		80.0	
		Z	3.19	67.60	16.55		80.0	
10497-AAA	LTE-TDD (SC-FDMA, 100% RB, 1.4 MHz, QPSK, UL Subframe=2,3,4,7,8,9)	X	0.98	60.00	7.66	2.23	80.0	± 9.6 %
		Y	1.21	61.40	9.41		80.0	
		Z	0.85	60.00	6.48		80.0	
10498-AAA	LTE-TDD (SC-FDMA, 100% RB, 1.4 MHz, 16-QAM, UL Subframe=2,3,4,7,8,9)	X	1.17	60.00	6.48	2.23	80.0	± 9.6 %
		Y	1.25	60.00	7.54		80.0	
		Z	1.13	60.00	5.14		80.0	
10499-AAA	LTE-TDD (SC-FDMA, 100% RB, 1.4 MHz, 64-QAM, UL Subframe=2,3,4,7,8,9)	X	1.19	60.00	6.32	2.23	80.0	± 9.6 %
		Y	1.26	60.00	7.39		80.0	
		Z	1.19	60.00	4.94		80.0	
10500-AAB	LTE-TDD (SC-FDMA, 100% RB, 3 MHz, QPSK, UL Subframe=2,3,4,7,8,9)	X	3.61	75.28	18.49	2.23	80.0	± 9.6 %
		Y	3.60	74.56	18.55		80.0	
		Z	2.31	70.18	15.90		80.0	
10501-AAB	LTE-TDD (SC-FDMA, 100% RB, 3 MHz, 16-QAM, UL Subframe=2,3,4,7,8,9)	X	2.83	68.30	14.92	2.23	80.0	± 9.6 %
		Y	3.15	69.25	15.83		80.0	
		Z	2.02	65.03	12.70		80.0	
10502-AAB	LTE-TDD (SC-FDMA, 100% RB, 3 MHz, 64-QAM, UL Subframe=2,3,4,7,8,9)	X	2.81	67.87	14.64	2.23	80.0	± 9.6 %
		Y	3.17	68.94	15.62		80.0	
		Z	2.02	64.68	12.43		80.0	
10503-AAD	LTE-TDD (SC-FDMA, 100% RB, 5 MHz, QPSK, UL Subframe=2,3,4,7,8,9)	X	3.64	74.69	19.28	2.23	80.0	± 9.6 %
		Y	3.66	73.87	19.00		80.0	
		Z	2.62	70.94	17.40		80.0	
10504-AAD	LTE-TDD (SC-FDMA, 100% RB, 5 MHz, 16-QAM, UL Subframe=2,3,4,7,8,9)	X	3.30	69.88	17.06	2.23	80.0	± 9.6 %
		Y	3.41	69.63	17.15		80.0	
		Z	2.69	67.93	15.70		80.0	
10505-AAD	LTE-TDD (SC-FDMA, 100% RB, 5 MHz, 64-QAM, UL Subframe=2,3,4,7,8,9)	X	3.35	69.57	16.93	2.23	80.0	± 9.6 %
		Y	3.48	69.39	17.05		80.0	
		Z	2.74	67.69	15.57		80.0	
10506-AAD	LTE-TDD (SC-FDMA, 100% RB, 10 MHz, QPSK, UL Subframe=2,3,4,7,8,9)	X	3.97	73.59	19.16	2.23	80.0	± 9.6 %
		Y	4.10	73.25	18.92		80.0	
		Z	3.08	70.76	17.76		80.0	
10507-AAD	LTE-TDD (SC-FDMA, 100% RB, 10 MHz, 16-QAM, UL Subframe=2,3,4,7,8,9)	X	3.61	69.10	17.52	2.23	80.0	± 9.6 %
		Y	3.74	68.99	17.47		80.0	
		Z	3.10	67.69	16.55		80.0	

10508-AAD	LTE-TDD (SC-FDMA, 100% RB, 10 MHz, 64-QAM, UL Subframe=2,3,4,7,8,9)	X	3.67	68.79	17.42	2.23	80.0	± 9.6 %
		Y	3.81	68.69	17.37		80.0	
		Z	3.18	67.50	16.48		80.0	
10509-AAD	LTE-TDD (SC-FDMA, 100% RB, 15 MHz, QPSK, UL Subframe=2,3,4,7,8,9)	X	4.19	71.63	18.46	2.23	80.0	± 9.6 %
		Y	4.34	71.54	18.29		80.0	
		Z	3.49	69.77	17.46		80.0	
10510-AAD	LTE-TDD (SC-FDMA, 100% RB, 15 MHz, 16-QAM, UL Subframe=2,3,4,7,8,9)	X	4.02	68.41	17.47	2.23	80.0	± 9.6 %
		Y	4.18	68.47	17.43		80.0	
		Z	3.54	67.28	16.67		80.0	
10511-AAD	LTE-TDD (SC-FDMA, 100% RB, 15 MHz, 64-QAM, UL Subframe=2,3,4,7,8,9)	X	4.08	68.19	17.41	2.23	80.0	± 9.6 %
		Y	4.24	68.23	17.36		80.0	
		Z	3.62	67.16	16.64		80.0	
10512-AAE	LTE-TDD (SC-FDMA, 100% RB, 20 MHz, QPSK, UL Subframe=2,3,4,7,8,9)	X	4.39	73.11	18.91	2.23	80.0	± 9.6 %
		Y	4.57	73.09	18.76		80.0	
		Z	3.55	70.80	17.76		80.0	
10513-AAE	LTE-TDD (SC-FDMA, 100% RB, 20 MHz, 16-QAM, UL Subframe=2,3,4,7,8,9)	X	3.92	68.58	17.57	2.23	80.0	± 9.6 %
		Y	4.08	68.69	17.52		80.0	
		Z	3.44	67.34	16.73		80.0	
10514-AAE	LTE-TDD (SC-FDMA, 100% RB, 20 MHz, 64-QAM, UL Subframe=2,3,4,7,8,9)	X	3.95	68.18	17.44	2.23	80.0	± 9.6 %
		Y	4.10	68.28	17.40		80.0	
		Z	3.50	67.06	16.65		80.0	
10515-AAA	IEEE 802.11b WiFi 2.4 GHz (DSSS, 2 Mbps, 99pc duty cycle)	X	0.85	63.44	14.76	0.00	150.0	± 9.6 %
		Y	0.97	65.05	16.30		150.0	
		Z	0.86	63.31	14.29		150.0	
10516-AAA	IEEE 802.11b WiFi 2.4 GHz (DSSS, 5.5 Mbps, 99pc duty cycle)	X	1.00	82.07	20.52	0.00	150.0	± 9.6 %
		Y	6.58	117.44	34.05		150.0	
		Z	0.52	71.82	16.88		150.0	
10517-AAA	IEEE 802.11b WiFi 2.4 GHz (DSSS, 11 Mbps, 99pc duty cycle)	X	0.71	65.99	15.57	0.00	150.0	± 9.6 %
		Y	0.90	69.36	18.20		150.0	
		Z	0.69	65.04	14.76		150.0	
10518-AAB	IEEE 802.11a/h WiFi 5 GHz (OFDM, 9 Mbps, 99pc duty cycle)	X	4.21	66.82	16.23	0.00	150.0	± 9.6 %
		Y	4.40	67.17	16.57		150.0	
		Z	4.07	67.02	15.99		150.0	
10519-AAB	IEEE 802.11a/h WiFi 5 GHz (OFDM, 12 Mbps, 99pc duty cycle)	X	4.34	66.98	16.31	0.00	150.0	± 9.6 %
		Y	4.56	67.34	16.66		150.0	
		Z	4.19	67.14	16.06		150.0	
10520-AAB	IEEE 802.11a/h WiFi 5 GHz (OFDM, 18 Mbps, 99pc duty cycle)	X	4.20	66.91	16.23	0.00	150.0	± 9.6 %
		Y	4.42	67.30	16.59		150.0	
		Z	4.06	67.06	15.98		150.0	
10521-AAB	IEEE 802.11a/h WiFi 5 GHz (OFDM, 24 Mbps, 99pc duty cycle)	X	4.13	66.86	16.20	0.00	150.0	± 9.6 %
		Y	4.35	67.28	16.58		150.0	
		Z	3.99	66.98	15.94		150.0	
10522-AAB	IEEE 802.11a/h WiFi 5 GHz (OFDM, 36 Mbps, 99pc duty cycle)	X	4.17	66.96	16.28	0.00	150.0	± 9.6 %
		Y	4.41	67.42	16.68		150.0	
		Z	4.01	67.01	15.97		150.0	

10523-AAB	IEEE 802.11a/h WiFi 5 GHz (OFDM, 48 Mbps, 99pc duty cycle)	X	4.12	67.05	16.25	0.00	150.0	± 9.6 %
		Y	4.33	67.40	16.59		150.0	
		Z	3.99	67.23	16.03		150.0	
10524-AAB	IEEE 802.11a/h WiFi 5 GHz (OFDM, 54 Mbps, 99pc duty cycle)	X	4.13	66.97	16.30	0.00	150.0	± 9.6 %
		Y	4.35	67.37	16.67		150.0	
		Z	3.98	67.09	16.04		150.0	
10525-AAB	IEEE 802.11ac WiFi (20MHz, MCS0, 99pc duty cycle)	X	4.18	66.09	15.94	0.00	150.0	± 9.6 %
		Y	4.39	66.46	16.28		150.0	
		Z	4.05	66.29	15.72		150.0	
10526-AAB	IEEE 802.11ac WiFi (20MHz, MCS1, 99pc duty cycle)	X	4.29	66.34	16.05	0.00	150.0	± 9.6 %
		Y	4.52	66.77	16.40		150.0	
		Z	4.14	66.48	15.80		150.0	
10527-AAB	IEEE 802.11ac WiFi (20MHz, MCS2, 99pc duty cycle)	X	4.23	66.32	15.98	0.00	150.0	± 9.6 %
		Y	4.45	66.75	16.35		150.0	
		Z	4.08	66.48	15.75		150.0	
10528-AAB	IEEE 802.11ac WiFi (20MHz, MCS3, 99pc duty cycle)	X	4.24	66.33	16.02	0.00	150.0	± 9.6 %
		Y	4.46	66.76	16.38		150.0	
		Z	4.09	66.47	15.77		150.0	
10529-AAB	IEEE 802.11ac WiFi (20MHz, MCS4, 99pc duty cycle)	X	4.24	66.33	16.02	0.00	150.0	± 9.6 %
		Y	4.46	66.76	16.38		150.0	
		Z	4.09	66.47	15.77		150.0	
10531-AAB	IEEE 802.11ac WiFi (20MHz, MCS6, 99pc duty cycle)	X	4.20	66.33	15.98	0.00	150.0	± 9.6 %
		Y	4.44	66.81	16.38		150.0	
		Z	4.04	66.44	15.72		150.0	
10532-AAB	IEEE 802.11ac WiFi (20MHz, MCS7, 99pc duty cycle)	X	4.09	66.19	15.91	0.00	150.0	± 9.6 %
		Y	4.31	66.68	16.32		150.0	
		Z	3.95	66.32	15.67		150.0	
10533-AAB	IEEE 802.11ac WiFi (20MHz, MCS8, 99pc duty cycle)	X	4.25	66.42	16.02	0.00	150.0	± 9.6 %
		Y	4.47	66.85	16.39		150.0	
		Z	4.09	66.58	15.79		150.0	
10534-AAB	IEEE 802.11ac WiFi (40MHz, MCS0, 99pc duty cycle)	X	4.82	66.28	16.10	0.00	150.0	± 9.6 %
		Y	5.01	66.66	16.38		150.0	
		Z	4.67	66.35	15.86		150.0	
10535-AAB	IEEE 802.11ac WiFi (40MHz, MCS1, 99pc duty cycle)	X	4.86	66.40	16.17	0.00	150.0	± 9.6 %
		Y	5.07	66.83	16.46		150.0	
		Z	4.69	66.42	15.91		150.0	
10536-AAB	IEEE 802.11ac WiFi (40MHz, MCS2, 99pc duty cycle)	X	4.75	66.37	16.13	0.00	150.0	± 9.6 %
		Y	4.96	66.84	16.44		150.0	
		Z	4.60	66.44	15.89		150.0	
10537-AAB	IEEE 802.11ac WiFi (40MHz, MCS3, 99pc duty cycle)	X	4.84	66.47	16.18	0.00	150.0	± 9.6 %
		Y	5.01	66.80	16.43		150.0	
		Z	4.68	66.51	15.93		150.0	
10538-AAB	IEEE 802.11ac WiFi (40MHz, MCS4, 99pc duty cycle)	X	4.88	66.35	16.16	0.00	150.0	± 9.6 %
		Y	5.08	66.76	16.45		150.0	
		Z	4.71	66.38	15.90		150.0	
10540-AAB	IEEE 802.11ac WiFi (40MHz, MCS6, 99pc duty cycle)	X	4.81	66.30	16.16	0.00	150.0	± 9.6 %
		Y	5.01	66.72	16.45		150.0	
		Z	4.65	66.34	15.90		150.0	

10541-AAB	IEEE 802.11ac WiFi (40MHz, MCS7, 99pc duty cycle)	X	4.80	66.22	16.09	0.00	150.0	± 9.6 %
		Y	4.99	66.61	16.37		150.0	
		Z	4.65	66.32	15.87		150.0	
10542-AAB	IEEE 802.11ac WiFi (40MHz, MCS8, 99pc duty cycle)	X	4.95	66.33	16.17	0.00	150.0	± 9.6 %
		Y	5.14	66.71	16.44		150.0	
		Z	4.79	66.39	15.92		150.0	
10543-AAB	IEEE 802.11ac WiFi (40MHz, MCS9, 99pc duty cycle)	X	5.05	66.50	16.28	0.00	150.0	± 9.6 %
		Y	5.22	66.78	16.50		150.0	
		Z	4.85	66.47	15.99		150.0	
10544-AAB	IEEE 802.11ac WiFi (80MHz, MCS0, 99pc duty cycle)	X	5.18	66.28	16.07	0.00	150.0	± 9.6 %
		Y	5.35	66.69	16.34		150.0	
		Z	5.04	66.36	15.85		150.0	
10545-AAB	IEEE 802.11ac WiFi (80MHz, MCS1, 99pc duty cycle)	X	5.38	66.85	16.32	0.00	150.0	± 9.6 %
		Y	5.55	67.20	16.55		150.0	
		Z	5.18	66.73	16.00		150.0	
10546-AAB	IEEE 802.11ac WiFi (80MHz, MCS2, 99pc duty cycle)	X	5.21	66.40	16.10	0.00	150.0	± 9.6 %
		Y	5.39	66.83	16.38		150.0	
		Z	5.06	66.45	15.86		150.0	
10547-AAB	IEEE 802.11ac WiFi (80MHz, MCS3, 99pc duty cycle)	X	5.34	66.70	16.25	0.00	150.0	± 9.6 %
		Y	5.47	66.95	16.43		150.0	
		Z	5.17	66.69	15.98		150.0	
10548-AAB	IEEE 802.11ac WiFi (80MHz, MCS4, 99pc duty cycle)	X	5.46	67.25	16.50	0.00	150.0	± 9.6 %
		Y	5.68	67.76	16.81		150.0	
		Z	5.19	66.93	16.08		150.0	
10550-AAB	IEEE 802.11ac WiFi (80MHz, MCS6, 99pc duty cycle)	X	5.33	66.84	16.34	0.00	150.0	± 9.6 %
		Y	5.46	67.06	16.50		150.0	
		Z	5.15	66.78	16.05		150.0	
10551-AAB	IEEE 802.11ac WiFi (80MHz, MCS7, 99pc duty cycle)	X	5.19	66.33	16.04	0.00	150.0	± 9.6 %
		Y	5.39	66.81	16.34		150.0	
		Z	5.04	66.38	15.81		150.0	
10552-AAB	IEEE 802.11ac WiFi (80MHz, MCS8, 99pc duty cycle)	X	5.18	66.41	16.08	0.00	150.0	± 9.6 %
		Y	5.36	66.79	16.33		150.0	
		Z	5.05	66.52	15.87		150.0	
10553-AAB	IEEE 802.11ac WiFi (80MHz, MCS9, 99pc duty cycle)	X	5.23	66.33	16.07	0.00	150.0	± 9.6 %
		Y	5.41	66.74	16.34		150.0	
		Z	5.09	66.42	15.85		150.0	
10554-AAC	IEEE 802.11ac WiFi (160MHz, MCS0, 99pc duty cycle)	X	5.62	66.62	16.16	0.00	150.0	± 9.6 %
		Y	5.77	67.01	16.40		150.0	
		Z	5.48	66.65	15.91		150.0	
10555-AAC	IEEE 802.11ac WiFi (160MHz, MCS1, 99pc duty cycle)	X	5.71	66.86	16.26	0.00	150.0	± 9.6 %
		Y	5.88	67.28	16.52		150.0	
		Z	5.54	66.80	15.97		150.0	
10556-AAC	IEEE 802.11ac WiFi (160MHz, MCS2, 99pc duty cycle)	X	5.78	67.06	16.35	0.00	150.0	± 9.6 %
		Y	5.92	67.39	16.56		150.0	
		Z	5.59	66.96	16.04		150.0	
10557-AAC	IEEE 802.11ac WiFi (160MHz, MCS3, 99pc duty cycle)	X	5.70	66.81	16.25	0.00	150.0	± 9.6 %
		Y	5.87	67.22	16.50		150.0	
		Z	5.54	66.82	15.99		150.0	

10558-AAC	IEEE 802.11ac WiFi (160MHz, MCS4, 99pc duty cycle)	X	5.68	66.79	16.25	0.00	150.0	± 9.6 %
		Y	5.89	67.32	16.56		150.0	
		Z	5.51	66.77	15.98		150.0	
10560-AAC	IEEE 802.11ac WiFi (160MHz, MCS6, 99pc duty cycle)	X	5.71	66.77	16.28	0.00	150.0	± 9.6 %
		Y	5.89	67.21	16.54		150.0	
		Z	5.55	66.76	16.02		150.0	
10561-AAC	IEEE 802.11ac WiFi (160MHz, MCS7, 99pc duty cycle)	X	5.66	66.78	16.32	0.00	150.0	± 9.6 %
		Y	5.83	67.22	16.58		150.0	
		Z	5.49	66.74	16.03		150.0	
10562-AAC	IEEE 802.11ac WiFi (160MHz, MCS8, 99pc duty cycle)	X	5.69	66.89	16.37	0.00	150.0	± 9.6 %
		Y	5.89	67.40	16.67		150.0	
		Z	5.52	66.86	16.09		150.0	
10563-AAC	IEEE 802.11ac WiFi (160MHz, MCS9, 99pc duty cycle)	X	5.83	67.00	16.39	0.00	150.0	± 9.6 %
		Y	5.99	67.36	16.62		150.0	
		Z	5.66	66.99	16.13		150.0	
10564-AAA	IEEE 802.11g WiFi 2.4 GHz (DSSS-OFDM, 9 Mbps, 99pc duty cycle)	X	4.52	66.80	16.34	0.46	150.0	± 9.6 %
		Y	4.71	67.11	16.64		150.0	
		Z	4.37	66.94	16.08		150.0	
10565-AAA	IEEE 802.11g WiFi 2.4 GHz (DSSS-OFDM, 12 Mbps, 99pc duty cycle)	X	4.71	67.24	16.68	0.46	150.0	± 9.6 %
		Y	4.92	67.55	16.97		150.0	
		Z	4.55	67.39	16.44		150.0	
10566-AAA	IEEE 802.11g WiFi 2.4 GHz (DSSS-OFDM, 18 Mbps, 99pc duty cycle)	X	4.55	67.03	16.47	0.46	150.0	± 9.6 %
		Y	4.75	67.36	16.77		150.0	
		Z	4.39	67.14	16.20		150.0	
10567-AAA	IEEE 802.11g WiFi 2.4 GHz (DSSS-OFDM, 24 Mbps, 99pc duty cycle)	X	4.59	67.50	16.90	0.46	150.0	± 9.6 %
		Y	4.80	67.84	17.20		150.0	
		Z	4.45	67.67	16.67		150.0	
10568-AAA	IEEE 802.11g WiFi 2.4 GHz (DSSS-OFDM, 36 Mbps, 99pc duty cycle)	X	4.43	66.68	16.15	0.46	150.0	± 9.6 %
		Y	4.65	67.08	16.49		150.0	
		Z	4.24	66.65	15.80		150.0	
10569-AAA	IEEE 802.11g WiFi 2.4 GHz (DSSS-OFDM, 48 Mbps, 99pc duty cycle)	X	4.60	67.82	17.09	0.46	150.0	± 9.6 %
		Y	4.78	68.07	17.33		150.0	
		Z	4.46	68.04	16.90		150.0	
10570-AAA	IEEE 802.11g WiFi 2.4 GHz (DSSS-OFDM, 54 Mbps, 99pc duty cycle)	X	4.58	67.53	16.94	0.46	150.0	± 9.6 %
		Y	4.79	67.84	17.22		150.0	
		Z	4.42	67.66	16.69		150.0	
10571-AAA	IEEE 802.11b WiFi 2.4 GHz (DSSS, 1 Mbps, 90pc duty cycle)	X	1.05	64.80	15.67	0.46	130.0	± 9.6 %
		Y	1.17	65.98	16.71		130.0	
		Z	1.00	63.98	14.85		130.0	
10572-AAA	IEEE 802.11b WiFi 2.4 GHz (DSSS, 2 Mbps, 90pc duty cycle)	X	1.07	65.55	16.13	0.46	130.0	± 9.6 %
		Y	1.19	66.83	17.22		130.0	
		Z	1.01	64.59	15.26		130.0	
10573-AAA	IEEE 802.11b WiFi 2.4 GHz (DSSS, 5.5 Mbps, 90pc duty cycle)	X	45.90	133.30	34.49	0.46	130.0	± 9.6 %
		Y	100.00	153.39	40.97		130.0	
		Z	1.58	84.66	22.16		130.0	
10574-AAA	IEEE 802.11b WiFi 2.4 GHz (DSSS, 11 Mbps, 90pc duty cycle)	X	1.35	74.48	20.46	0.46	130.0	± 9.6 %
		Y	1.66	77.75	22.43		130.0	
		Z	1.11	71.01	18.64		130.0	

10575-AAA	IEEE 802.11g WiFi 2.4 GHz (DSSS-OFDM, 6 Mbps, 90pc duty cycle)	X	4.32	66.63	16.40	0.46	130.0	± 9.6 %
		Y	4.48	66.85	16.63		130.0	
		Z	4.16	66.71	16.08		130.0	
10576-AAA	IEEE 802.11g WiFi 2.4 GHz (DSSS-OFDM, 9 Mbps, 90pc duty cycle)	X	4.35	66.88	16.51	0.46	130.0	± 9.6 %
		Y	4.52	67.08	16.73		130.0	
		Z	4.19	66.99	16.21		130.0	
10577-AAA	IEEE 802.11g WiFi 2.4 GHz (DSSS-OFDM, 12 Mbps, 90pc duty cycle)	X	4.50	67.10	16.65	0.46	130.0	± 9.6 %
		Y	4.69	67.32	16.88		130.0	
		Z	4.33	67.20	16.35		130.0	
10578-AAA	IEEE 802.11g WiFi 2.4 GHz (DSSS-OFDM, 18 Mbps, 90pc duty cycle)	X	4.42	67.29	16.79	0.46	130.0	± 9.6 %
		Y	4.60	67.52	17.02		130.0	
		Z	4.26	67.40	16.51		130.0	
10579-AAA	IEEE 802.11g WiFi 2.4 GHz (DSSS-OFDM, 24 Mbps, 90pc duty cycle)	X	4.15	66.32	15.93	0.46	130.0	± 9.6 %
		Y	4.34	66.61	16.20		130.0	
		Z	3.97	66.27	15.55		130.0	
10580-AAA	IEEE 802.11g WiFi 2.4 GHz (DSSS-OFDM, 36 Mbps, 90pc duty cycle)	X	4.18	66.36	15.93	0.46	130.0	± 9.6 %
		Y	4.38	66.67	16.22		130.0	
		Z	3.97	66.21	15.49		130.0	
10581-AAA	IEEE 802.11g WiFi 2.4 GHz (DSSS-OFDM, 48 Mbps, 90pc duty cycle)	X	4.34	67.41	16.79	0.46	130.0	± 9.6 %
		Y	4.51	67.61	16.99		130.0	
		Z	4.18	67.53	16.51		130.0	
10582-AAA	IEEE 802.11g WiFi 2.4 GHz (DSSS-OFDM, 54 Mbps, 90pc duty cycle)	X	4.07	66.06	15.68	0.46	130.0	± 9.6 %
		Y	4.26	66.35	15.96		130.0	
		Z	3.88	65.96	15.27		130.0	
10583-AAB	IEEE 802.11a/h WiFi 5 GHz (OFDM, 6 Mbps, 90pc duty cycle)	X	4.32	66.63	16.40	0.46	130.0	± 9.6 %
		Y	4.48	66.85	16.63		130.0	
		Z	4.16	66.71	16.08		130.0	
10584-AAB	IEEE 802.11a/h WiFi 5 GHz (OFDM, 9 Mbps, 90pc duty cycle)	X	4.35	66.88	16.51	0.46	130.0	± 9.6 %
		Y	4.52	67.08	16.73		130.0	
		Z	4.19	66.99	16.21		130.0	
10585-AAB	IEEE 802.11a/h WiFi 5 GHz (OFDM, 12 Mbps, 90pc duty cycle)	X	4.50	67.10	16.65	0.46	130.0	± 9.6 %
		Y	4.69	67.32	16.88		130.0	
		Z	4.33	67.20	16.35		130.0	
10586-AAB	IEEE 802.11a/h WiFi 5 GHz (OFDM, 18 Mbps, 90pc duty cycle)	X	4.42	67.29	16.79	0.46	130.0	± 9.6 %
		Y	4.60	67.52	17.02		130.0	
		Z	4.26	67.40	16.51		130.0	
10587-AAB	IEEE 802.11a/h WiFi 5 GHz (OFDM, 24 Mbps, 90pc duty cycle)	X	4.15	66.32	15.93	0.46	130.0	± 9.6 %
		Y	4.34	66.61	16.20		130.0	
		Z	3.97	66.27	15.55		130.0	
10588-AAB	IEEE 802.11a/h WiFi 5 GHz (OFDM, 36 Mbps, 90pc duty cycle)	X	4.18	66.36	15.93	0.46	130.0	± 9.6 %
		Y	4.38	66.67	16.22		130.0	
		Z	3.97	66.21	15.49		130.0	
10589-AAB	IEEE 802.11a/h WiFi 5 GHz (OFDM, 48 Mbps, 90pc duty cycle)	X	4.34	67.41	16.79	0.46	130.0	± 9.6 %
		Y	4.51	67.61	16.99		130.0	
		Z	4.18	67.53	16.51		130.0	
10590-AAB	IEEE 802.11a/h WiFi 5 GHz (OFDM, 54 Mbps, 90pc duty cycle)	X	4.07	66.06	15.68	0.46	130.0	± 9.6 %
		Y	4.26	66.35	15.96		130.0	
		Z	3.88	65.96	15.27		130.0	

10591-AAB	IEEE 802.11n (HT Mixed, 20MHz, MCS0, 90pc duty cycle)	X	4.48	66.74	16.55	0.46	130.0	± 9.6 %
		Y	4.64	66.92	16.75		130.0	
		Z	4.33	66.86	16.26		130.0	
10592-AAB	IEEE 802.11n (HT Mixed, 20MHz, MCS1, 90pc duty cycle)	X	4.58	67.02	16.67	0.46	130.0	± 9.6 %
		Y	4.77	67.23	16.87		130.0	
		Z	4.41	67.10	16.37		130.0	
10593-AAB	IEEE 802.11n (HT Mixed, 20MHz, MCS2, 90pc duty cycle)	X	4.50	66.88	16.51	0.46	130.0	± 9.6 %
		Y	4.68	67.11	16.73		130.0	
		Z	4.33	66.96	16.20		130.0	
10594-AAB	IEEE 802.11n (HT Mixed, 20MHz, MCS3, 90pc duty cycle)	X	4.56	67.08	16.70	0.46	130.0	± 9.6 %
		Y	4.74	67.30	16.91		130.0	
		Z	4.39	67.16	16.40		130.0	
10595-AAB	IEEE 802.11n (HT Mixed, 20MHz, MCS4, 90pc duty cycle)	X	4.53	67.07	16.60	0.46	130.0	± 9.6 %
		Y	4.71	67.27	16.81		130.0	
		Z	4.35	67.13	16.30		130.0	
10596-AAB	IEEE 802.11n (HT Mixed, 20MHz, MCS5, 90pc duty cycle)	X	4.45	67.00	16.58	0.46	130.0	± 9.6 %
		Y	4.64	67.24	16.80		130.0	
		Z	4.27	67.01	16.25		130.0	
10597-AAB	IEEE 802.11n (HT Mixed, 20MHz, MCS6, 90pc duty cycle)	X	4.40	66.85	16.41	0.46	130.0	± 9.6 %
		Y	4.59	67.11	16.65		130.0	
		Z	4.23	66.87	16.08		130.0	
10598-AAB	IEEE 802.11n (HT Mixed, 20MHz, MCS7, 90pc duty cycle)	X	4.41	67.15	16.73	0.46	130.0	± 9.6 %
		Y	4.59	67.39	16.96		130.0	
		Z	4.26	67.25	16.45		130.0	
10599-AAB	IEEE 802.11n (HT Mixed, 40MHz, MCS0, 90pc duty cycle)	X	5.20	67.26	16.87	0.46	130.0	± 9.6 %
		Y	5.33	67.39	16.98		130.0	
		Z	5.07	67.39	16.64		130.0	
10600-AAB	IEEE 802.11n (HT Mixed, 40MHz, MCS1, 90pc duty cycle)	X	5.34	67.77	17.10	0.46	130.0	± 9.6 %
		Y	5.47	67.86	17.18		130.0	
		Z	5.05	67.37	16.59		130.0	
10601-AAB	IEEE 802.11n (HT Mixed, 40MHz, MCS2, 90pc duty cycle)	X	5.22	67.48	16.98	0.46	130.0	± 9.6 %
		Y	5.34	67.55	17.05		130.0	
		Z	5.03	67.40	16.63		130.0	
10602-AAB	IEEE 802.11n (HT Mixed, 40MHz, MCS3, 90pc duty cycle)	X	5.31	67.47	16.88	0.46	130.0	± 9.6 %
		Y	5.47	67.70	17.03		130.0	
		Z	5.04	67.16	16.42		130.0	
10603-AAB	IEEE 802.11n (HT Mixed, 40MHz, MCS4, 90pc duty cycle)	X	5.34	67.68	17.13	0.46	130.0	± 9.6 %
		Y	5.55	68.04	17.35		130.0	
		Z	5.07	67.36	16.68		130.0	
10604-AAB	IEEE 802.11n (HT Mixed, 40MHz, MCS5, 90pc duty cycle)	X	5.19	67.13	16.83	0.46	130.0	± 9.6 %
		Y	5.43	67.67	17.14		130.0	
		Z	4.98	67.00	16.46		130.0	
10605-AAB	IEEE 802.11n (HT Mixed, 40MHz, MCS6, 90pc duty cycle)	X	5.28	67.45	16.99	0.46	130.0	± 9.6 %
		Y	5.44	67.68	17.14		130.0	
		Z	5.02	67.15	16.54		130.0	
10606-AAB	IEEE 802.11n (HT Mixed, 40MHz, MCS7, 90pc duty cycle)	X	5.09	66.96	16.59	0.46	130.0	± 9.6 %
		Y	5.20	67.02	16.66		130.0	
		Z	4.89	66.84	16.22		130.0	

10607-AAB	IEEE 802.11ac WiFi (20MHz, MCS0, 90pc duty cycle)	X	4.33	66.11	16.21	0.46	130.0	± 9.6 %
		Y	4.50	66.32	16.42		130.0	
		Z	4.18	66.24	15.93		130.0	
10608-AAB	IEEE 802.11ac WiFi (20MHz, MCS1, 90pc duty cycle)	X	4.46	66.41	16.34	0.46	130.0	± 9.6 %
		Y	4.65	66.67	16.57		130.0	
		Z	4.28	66.49	16.05		130.0	
10609-AAB	IEEE 802.11ac WiFi (20MHz, MCS2, 90pc duty cycle)	X	4.35	66.23	16.15	0.46	130.0	± 9.6 %
		Y	4.54	66.50	16.39		130.0	
		Z	4.18	66.29	15.84		130.0	
10610-AAB	IEEE 802.11ac WiFi (20MHz, MCS3, 90pc duty cycle)	X	4.41	66.44	16.34	0.46	130.0	± 9.6 %
		Y	4.59	66.68	16.57		130.0	
		Z	4.24	66.51	16.05		130.0	
10611-AAB	IEEE 802.11ac WiFi (20MHz, MCS4, 90pc duty cycle)	X	4.32	66.20	16.17	0.46	130.0	± 9.6 %
		Y	4.51	66.47	16.40		130.0	
		Z	4.14	66.25	15.86		130.0	
10612-AAB	IEEE 802.11ac WiFi (20MHz, MCS5, 90pc duty cycle)	X	4.30	66.31	16.19	0.46	130.0	± 9.6 %
		Y	4.50	66.61	16.44		130.0	
		Z	4.10	66.27	15.84		130.0	
10613-AAB	IEEE 802.11ac WiFi (20MHz, MCS6, 90pc duty cycle)	X	4.29	66.09	16.01	0.46	130.0	± 9.6 %
		Y	4.49	66.41	16.28		130.0	
		Z	4.10	66.08	15.67		130.0	
10614-AAB	IEEE 802.11ac WiFi (20MHz, MCS7, 90pc duty cycle)	X	4.28	66.40	16.32	0.46	130.0	± 9.6 %
		Y	4.47	66.69	16.57		130.0	
		Z	4.11	66.46	16.02		130.0	
10615-AAB	IEEE 802.11ac WiFi (20MHz, MCS8, 90pc duty cycle)	X	4.30	66.00	15.89	0.46	130.0	± 9.6 %
		Y	4.49	66.26	16.14		130.0	
		Z	4.11	66.01	15.56		130.0	
10616-AAB	IEEE 802.11ac WiFi (40MHz, MCS0, 90pc duty cycle)	X	4.98	66.35	16.40	0.46	130.0	± 9.6 %
		Y	5.14	66.59	16.56		130.0	
		Z	4.81	66.34	16.11		130.0	
10617-AAB	IEEE 802.11ac WiFi (40MHz, MCS1, 90pc duty cycle)	X	5.02	66.47	16.44	0.46	130.0	± 9.6 %
		Y	5.20	66.77	16.63		130.0	
		Z	4.82	66.38	16.11		130.0	
10618-AAB	IEEE 802.11ac WiFi (40MHz, MCS2, 90pc duty cycle)	X	4.92	66.49	16.47	0.46	130.0	± 9.6 %
		Y	5.11	66.84	16.68		130.0	
		Z	4.75	66.49	16.18		130.0	
10619-AAB	IEEE 802.11ac WiFi (40MHz, MCS3, 90pc duty cycle)	X	4.99	66.47	16.38	0.46	130.0	± 9.6 %
		Y	5.12	66.62	16.50		130.0	
		Z	4.78	66.37	16.04		130.0	
10620-AAB	IEEE 802.11ac WiFi (40MHz, MCS4, 90pc duty cycle)	X	5.02	66.35	16.37	0.46	130.0	± 9.6 %
		Y	5.19	66.61	16.54		130.0	
		Z	4.81	66.23	16.02		130.0	
10621-AAB	IEEE 802.11ac WiFi (40MHz, MCS5, 90pc duty cycle)	X	5.02	66.45	16.56	0.46	130.0	± 9.6 %
		Y	5.19	66.74	16.74		130.0	
		Z	4.86	66.48	16.29		130.0	
10622-AAB	IEEE 802.11ac WiFi (40MHz, MCS6, 90pc duty cycle)	X	5.02	66.56	16.61	0.46	130.0	± 9.6 %
		Y	5.19	66.85	16.79		130.0	
		Z	4.84	66.54	16.31		130.0	

10623-AAB	IEEE 802.11ac WiFi (40MHz, MCS7, 90pc duty cycle)	X	4.91	66.09	16.22	0.46	130.0	± 9.6 %
		Y	5.06	66.33	16.38		130.0	
		Z	4.74	66.10	15.92		130.0	
10624-AAB	IEEE 802.11ac WiFi (40MHz, MCS8, 90pc duty cycle)	X	5.10	66.37	16.43	0.46	130.0	± 9.6 %
		Y	5.27	66.61	16.59		130.0	
		Z	4.91	66.33	16.12		130.0	
10625-AAB	IEEE 802.11ac WiFi (40MHz, MCS9, 90pc duty cycle)	X	5.22	66.63	16.63	0.46	130.0	± 9.6 %
		Y	5.38	66.84	16.77		130.0	
		Z	5.00	66.51	16.28		130.0	
10626-AAB	IEEE 802.11ac WiFi (80MHz, MCS0, 90pc duty cycle)	X	5.32	66.29	16.33	0.46	130.0	± 9.6 %
		Y	5.46	66.57	16.48		130.0	
		Z	5.17	66.30	16.05		130.0	
10627-AAB	IEEE 802.11ac WiFi (80MHz, MCS1, 90pc duty cycle)	X	5.60	67.10	16.71	0.46	130.0	± 9.6 %
		Y	5.73	67.29	16.81		130.0	
		Z	5.36	66.86	16.31		130.0	
10628-AAB	IEEE 802.11ac WiFi (80MHz, MCS2, 90pc duty cycle)	X	5.31	66.25	16.20	0.46	130.0	± 9.6 %
		Y	5.46	66.55	16.37		130.0	
		Z	5.14	66.21	15.90		130.0	
10629-AAB	IEEE 802.11ac WiFi (80MHz, MCS3, 90pc duty cycle)	X	5.49	66.72	16.44	0.46	130.0	± 9.6 %
		Y	5.57	66.76	16.47		130.0	
		Z	5.29	66.59	16.09		130.0	
10630-AAB	IEEE 802.11ac WiFi (80MHz, MCS4, 90pc duty cycle)	X	5.68	67.51	16.83	0.46	130.0	± 9.6 %
		Y	5.90	67.96	17.07		130.0	
		Z	5.34	66.93	16.27		130.0	
10631-AAB	IEEE 802.11ac WiFi (80MHz, MCS5, 90pc duty cycle)	X	5.63	67.48	17.02	0.46	130.0	± 9.6 %
		Y	5.82	67.86	17.23		130.0	
		Z	5.40	67.29	16.67		130.0	
10632-AAB	IEEE 802.11ac WiFi (80MHz, MCS6, 90pc duty cycle)	X	5.65	67.46	17.04	0.46	130.0	± 9.6 %
		Y	5.72	67.47	17.05		130.0	
		Z	5.44	67.32	16.69		130.0	
10633-AAB	IEEE 802.11ac WiFi (80MHz, MCS7, 90pc duty cycle)	X	5.32	66.30	16.27	0.46	130.0	± 9.6 %
		Y	5.51	66.72	16.50		130.0	
		Z	5.15	66.30	15.99		130.0	
10634-AAB	IEEE 802.11ac WiFi (80MHz, MCS8, 90pc duty cycle)	X	5.36	66.54	16.45	0.46	130.0	± 9.6 %
		Y	5.51	66.83	16.61		130.0	
		Z	5.20	66.59	16.19		130.0	
10635-AAB	IEEE 802.11ac WiFi (80MHz, MCS9, 90pc duty cycle)	X	5.20	65.70	15.73	0.46	130.0	± 9.6 %
		Y	5.36	66.01	15.90		130.0	
		Z	5.03	65.65	15.41		130.0	
10636-AAC	IEEE 802.11ac WiFi (160MHz, MCS0, 90pc duty cycle)	X	5.78	66.65	16.42	0.46	130.0	± 9.6 %
		Y	5.90	66.91	16.56		130.0	
		Z	5.61	66.61	16.12		130.0	
10637-AAC	IEEE 802.11ac WiFi (160MHz, MCS1, 90pc duty cycle)	X	5.90	67.00	16.58	0.46	130.0	± 9.6 %
		Y	6.04	67.28	16.73		130.0	
		Z	5.69	66.82	16.22		130.0	
10638-AAC	IEEE 802.11ac WiFi (160MHz, MCS2, 90pc duty cycle)	X	5.94	67.10	16.61	0.46	130.0	± 9.6 %
		Y	6.05	67.30	16.71		130.0	
		Z	5.75	66.99	16.28		130.0	

10639-AAC	IEEE 802.11ac WiFi (160MHz, MCS3, 90pc duty cycle)	X	5.87	66.88	16.54	0.46	130.0	± 9.6 %
		Y	6.00	67.17	16.69		130.0	
		Z	5.69	66.82	16.24		130.0	
10640-AAC	IEEE 802.11ac WiFi (160MHz, MCS4, 90pc duty cycle)	X	5.79	66.67	16.37	0.46	130.0	± 9.6 %
		Y	5.97	67.09	16.59		130.0	
		Z	5.60	66.55	16.04		130.0	
10641-AAC	IEEE 802.11ac WiFi (160MHz, MCS5, 90pc duty cycle)	X	5.95	66.94	16.53	0.46	130.0	± 9.6 %
		Y	6.07	67.17	16.65		130.0	
		Z	5.72	66.71	16.14		130.0	
10642-AAC	IEEE 802.11ac WiFi (160MHz, MCS6, 90pc duty cycle)	X	5.93	67.02	16.75	0.46	130.0	± 9.6 %
		Y	6.09	67.36	16.93		130.0	
		Z	5.75	66.97	16.45		130.0	
10643-AAC	IEEE 802.11ac WiFi (160MHz, MCS7, 90pc duty cycle)	X	5.79	66.72	16.48	0.46	130.0	± 9.6 %
		Y	5.94	67.06	16.66		130.0	
		Z	5.59	66.57	16.12		130.0	
10644-AAC	IEEE 802.11ac WiFi (160MHz, MCS8, 90pc duty cycle)	X	5.83	66.84	16.56	0.46	130.0	± 9.6 %
		Y	6.00	67.25	16.78		130.0	
		Z	5.64	66.74	16.23		130.0	
10645-AAC	IEEE 802.11ac WiFi (160MHz, MCS9, 90pc duty cycle)	X	6.00	67.07	16.64	0.46	130.0	± 9.6 %
		Y	6.21	67.54	16.89		130.0	
		Z	5.77	66.86	16.26		130.0	
10646-AAE	LTE-TDD (SC-FDMA, 1 RB, 5 MHz, QPSK, UL Subframe=2,7)	X	10.86	99.58	34.54	9.30	60.0	± 9.6 %
		Y	12.75	100.34	33.52		60.0	
		Z	5.31	84.82	28.77		60.0	
10647-AAE	LTE-TDD (SC-FDMA, 1 RB, 20 MHz, QPSK, UL Subframe=2,7)	X	9.54	97.33	33.94	9.30	60.0	± 9.6 %
		Y	11.34	98.50	33.07		60.0	
		Z	4.72	82.70	28.08		60.0	
10648-AAA	CDMA2000 (1x Advanced)	X	0.33	60.00	5.33	0.00	150.0	± 9.6 %
		Y	0.54	62.99	9.08		150.0	
		Z	0.29	60.00	4.72		150.0	
10652-AAC	LTE-TDD (OFDMA, 5 MHz, E-TM 3.1, Clipping 44%)	X	3.41	67.48	16.36	2.23	80.0	± 9.6 %
		Y	3.57	67.58	16.63		80.0	
		Z	3.03	66.68	15.51		80.0	
10653-AAC	LTE-TDD (OFDMA, 10 MHz, E-TM 3.1, Clipping 44%)	X	3.91	66.47	16.67	2.23	80.0	± 9.6 %
		Y	4.05	66.58	16.80		80.0	
		Z	3.59	65.97	16.06		80.0	
10654-AAC	LTE-TDD (OFDMA, 15 MHz, E-TM 3.1, Clipping 44%)	X	3.92	66.00	16.72	2.23	80.0	± 9.6 %
		Y	4.05	66.15	16.82		80.0	
		Z	3.64	65.53	16.15		80.0	
10655-AAD	LTE-TDD (OFDMA, 20 MHz, E-TM 3.1, Clipping 44%)	X	4.00	65.85	16.74	2.23	80.0	± 9.6 %
		Y	4.12	66.05	16.84		80.0	
		Z	3.73	65.37	16.19		80.0	
10658-AAA	Pulse Waveform (200Hz, 10%)	X	8.11	79.21	17.64	10.00	50.0	± 9.6 %
		Y	5.18	73.01	14.95		50.0	
		Z	4.63	71.52	13.37		50.0	
10659-AAA	Pulse Waveform (200Hz, 20%)	X	100.00	107.57	23.76	6.99	60.0	± 9.6 %
		Y	5.94	76.36	14.90		60.0	
		Z	5.07	74.93	13.37		60.0	

10660-AAA	Pulse Waveform (200Hz, 40%)	X	100.00	102.40	19.98	3.98	80.0	± 9.6 %
		Y	100.00	101.57	19.73		80.0	
		Z	9.47	80.34	13.09		80.0	
10661-AAA	Pulse Waveform (200Hz, 60%)	X	0.90	65.14	7.58	2.22	100.0	± 9.6 %
		Y	100.00	98.16	17.19		100.0	
		Z	0.28	60.00	4.46		100.0	
10662-AAA	Pulse Waveform (200Hz, 80%)	X	42.12	60.80	1.47	0.97	120.0	± 9.6 %
		Y	0.19	60.00	4.14		120.0	
		Z	1.43	244.46	28.28		120.0	

^E Uncertainty is determined using the max. deviation from linear response applying rectangular distribution and is expressed for the square of the field value.

Appendix E – Dipole Calibration Data Sheets



Accredited by the Swiss Accreditation Service (SAS)
The Swiss Accreditation Service is one of the signatories to the EA
Multilateral Agreement for the recognition of calibration certificates

Accreditation No.: **SCS 0108**

Client **RF Exposure Lab**

Certificate No: **D750V3-1016_Jul18**

CALIBRATION CERTIFICATE

Object **D750V3 - SN:1016**

Calibration procedure(s) **QA CAL-05.v10
Calibration procedure for dipole validation kits above 700 MHz**

Calibration date: **July 13, 2018**

This calibration certificate documents the traceability to national standards, which realize the physical units of measurements (SI).
The measurements and the uncertainties with confidence probability are given on the following pages and are part of the certificate.

All calibrations have been conducted in the closed laboratory facility: environment temperature (22 ± 3)°C and humidity < 70%.

Calibration Equipment used (M&TE critical for calibration)

Primary Standards	ID #	Cal Date (Certificate No.)	Scheduled Calibration
Power meter NRP	SN: 104778	04-Apr-18 (No. 217-02672/02673)	Apr-19
Power sensor NRP-Z91	SN: 103244	04-Apr-18 (No. 217-02672)	Apr-19
Power sensor NRP-Z91	SN: 103245	04-Apr-18 (No. 217-02673)	Apr-19
Reference 20 dB Attenuator	SN: 5058 (20k)	04-Apr-18 (No. 217-02682)	Apr-19
Type-N mismatch combination	SN: 5047.2 / 06327	04-Apr-18 (No. 217-02683)	Apr-19
Reference Probe EX3DV4	SN: 7349	30-Dec-17 (No. EX3-7349_Dec17)	Dec-18
DAE4	SN: 601	26-Oct-17 (No. DAE4-601_Oct17)	Oct-18

Secondary Standards	ID #	Check Date (in house)	Scheduled Check
Power meter EPM-442A	SN: GB37480704	07-Oct-15 (in house check Oct-16)	In house check: Oct-18
Power sensor HP 8481A	SN: US37292783	07-Oct-15 (in house check Oct-16)	In house check: Oct-18
Power sensor HP 8481A	SN: MY41092317	07-Oct-15 (in house check Oct-16)	In house check: Oct-18
RF generator R&S SMT-06	SN: 100972	15-Jun-15 (in house check Oct-16)	In house check: Oct-18
Network Analyzer Agilent E8358A	SN: US41080477	31-Mar-14 (in house check Oct-17)	In house check: Oct-18

Calibrated by: **Manu Seitz** Name **Laboratory Technician** Function  Signature

Approved by: **Katja Pokovic** Name **Technical Manager** Function  Signature

Issued: July 16, 2018

This calibration certificate shall not be reproduced except in full without written approval of the laboratory.



Accredited by the Swiss Accreditation Service (SAS)

The Swiss Accreditation Service is one of the signatories to the EA
Multilateral Agreement for the recognition of calibration certificates

Accreditation No.: **SCS 0108**

Glossary:

TSL	tissue simulating liquid
ConvF	sensitivity in TSL / NORM x,y,z
N/A	not applicable or not measured

Calibration is Performed According to the Following Standards:

- IEEE Std 1528-2013, "IEEE Recommended Practice for Determining the Peak Spatial-Averaged Specific Absorption Rate (SAR) in the Human Head from Wireless Communications Devices: Measurement Techniques", June 2013
- IEC 62209-1, "Measurement procedure for the assessment of Specific Absorption Rate (SAR) from hand-held and body-mounted devices used next to the ear (frequency range of 300 MHz to 6 GHz)", July 2016
- IEC 62209-2, "Procedure to determine the Specific Absorption Rate (SAR) for wireless communication devices used in close proximity to the human body (frequency range of 30 MHz to 6 GHz)", March 2010
- KDB 865664, "SAR Measurement Requirements for 100 MHz to 6 GHz"

Additional Documentation:

- DASY4/5 System Handbook

Methods Applied and Interpretation of Parameters:

- Measurement Conditions:** Further details are available from the Validation Report at the end of the certificate. All figures stated in the certificate are valid at the frequency indicated.
- Antenna Parameters with TSL:** The dipole is mounted with the spacer to position its feed point exactly below the center marking of the flat phantom section, with the arms oriented parallel to the body axis.
- Feed Point Impedance and Return Loss:** These parameters are measured with the dipole positioned under the liquid filled phantom. The impedance stated is transformed from the measurement at the SMA connector to the feed point. The Return Loss ensures low reflected power. No uncertainty required.
- Electrical Delay:** One-way delay between the SMA connector and the antenna feed point. No uncertainty required.
- SAR measured:** SAR measured at the stated antenna input power.
- SAR normalized:** SAR as measured, normalized to an input power of 1 W at the antenna connector.
- SAR for nominal TSL parameters:** The measured TSL parameters are used to calculate the nominal SAR result.

The reported uncertainty of measurement is stated as the standard uncertainty of measurement multiplied by the coverage factor $k=2$, which for a normal distribution corresponds to a coverage probability of approximately 95%.

Measurement Conditions

DASY system configuration, as far as not given on page 1.

DASY Version	DASY5	V52.10.1
Extrapolation	Advanced Extrapolation	
Phantom	Modular Flat Phantom	
Distance Dipole Center - TSL	15 mm	with Spacer
Zoom Scan Resolution	dx, dy, dz = 5 mm	
Frequency	750 MHz \pm 1 MHz	

Head TSL parameters

The following parameters and calculations were applied.

	Temperature	Permittivity	Conductivity
Nominal Head TSL parameters	22.0 °C	41.9	0.89 mho/m
Measured Head TSL parameters	(22.0 \pm 0.2) °C	40.9 \pm 6 %	0.89 mho/m \pm 6 %
Head TSL temperature change during test	< 0.5 °C	----	----

SAR result with Head TSL

SAR averaged over 1 cm³ (1 g) of Head TSL	Condition	
SAR measured	250 mW input power	2.07 W/kg
SAR for nominal Head TSL parameters	normalized to 1W	8.23 W/kg \pm 17.0 % (k=2)

SAR averaged over 10 cm³ (10 g) of Head TSL	condition	
SAR measured	250 mW input power	1.35 W/kg
SAR for nominal Head TSL parameters	normalized to 1W	5.38 W/kg \pm 16.5 % (k=2)

Body TSL parameters

The following parameters and calculations were applied.

	Temperature	Permittivity	Conductivity
Nominal Body TSL parameters	22.0 °C	55.5	0.96 mho/m
Measured Body TSL parameters	(22.0 \pm 0.2) °C	55.3 \pm 6 %	0.96 mho/m \pm 6 %
Body TSL temperature change during test	< 0.5 °C	----	----

SAR result with Body TSL

SAR averaged over 1 cm³ (1 g) of Body TSL	Condition	
SAR measured	250 mW input power	2.14 W/kg
SAR for nominal Body TSL parameters	normalized to 1W	8.55 W/kg \pm 17.0 % (k=2)

SAR averaged over 10 cm³ (10 g) of Body TSL	condition	
SAR measured	250 mW input power	1.41 W/kg
SAR for nominal Body TSL parameters	normalized to 1W	5.64 W/kg \pm 16.5 % (k=2)

Appendix (Additional assessments outside the scope of SCS 0108)

Antenna Parameters with Head TSL

Impedance, transformed to feed point	53.4 Ω + 0.0 j Ω
Return Loss	- 29.6 dB

Antenna Parameters with Body TSL

Impedance, transformed to feed point	48.8 Ω - 2.6 j Ω
Return Loss	- 30.7 dB

General Antenna Parameters and Design

Electrical Delay (one direction)	1.038 ns
----------------------------------	----------

After long term use with 100W radiated power, only a slight warming of the dipole near the feedpoint can be measured.

The dipole is made of standard semirigid coaxial cable. The center conductor of the feeding line is directly connected to the second arm of the dipole. The antenna is therefore short-circuited for DC-signals. On some of the dipoles, small end caps are added to the dipole arms in order to improve matching when loaded according to the position as explained in the "Measurement Conditions" paragraph. The SAR data are not affected by this change. The overall dipole length is still according to the Standard.

No excessive force must be applied to the dipole arms, because they might bend or the soldered connections near the feedpoint may be damaged.

Additional EUT Data

Manufactured by	SPEAG
Manufactured on	March 22, 2010

DASY5 Validation Report for Head TSL

Date: 13.07.2018

Test Laboratory: SPEAG, Zurich, Switzerland

DUT: Dipole 750 MHz; Type: D750V3; Serial: D750V3 - SN:1016

Communication System: UID 0 - CW; Frequency: 750 MHz

Medium parameters used: $f = 750$ MHz; $\sigma = 0.89$ S/m; $\epsilon_r = 40.9$; $\rho = 1000$ kg/m³

Phantom section: Flat Section

Measurement Standard: DASY5 (IEEE/IEC/ANSI C63.19-2011)

DASY52 Configuration:

- Probe: EX3DV4 - SN7349; ConvF(10.22, 10.22, 10.22) @ 750 MHz; Calibrated: 30.12.2017
- Sensor-Surface: 1.4mm (Mechanical Surface Detection)
- Electronics: DAE4 Sn601; Calibrated: 26.10.2017
- Phantom: Flat Phantom 4.9 (front); Type: QD 00L P49 AA; Serial: 1001
- DASY52 52.10.1(1476); SEMCAD X 14.6.11(7439)

Dipole Calibration for Head Tissue/Pin=250 mW, d=15mm/Zoom Scan (7x7x7)/Cube 0:

Measurement grid: dx=5mm, dy=5mm, dz=5mm

Reference Value = 59.03 V/m; Power Drift = -0.03 dB

Peak SAR (extrapolated) = 3.10 W/kg

SAR(1 g) = 2.07 W/kg; SAR(10 g) = 1.35 W/kg

Maximum value of SAR (measured) = 2.76 W/kg

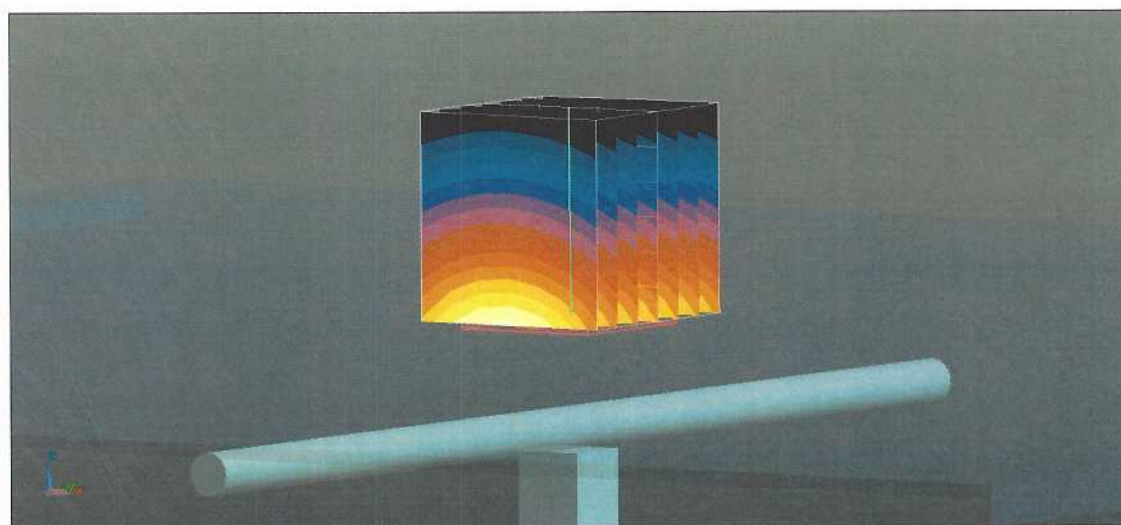
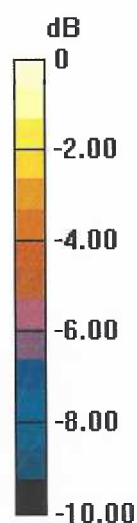

0 dB = 2.76 W/kg = 4.41 dBW/kg

Impedance Measurement Plot for Head TSL

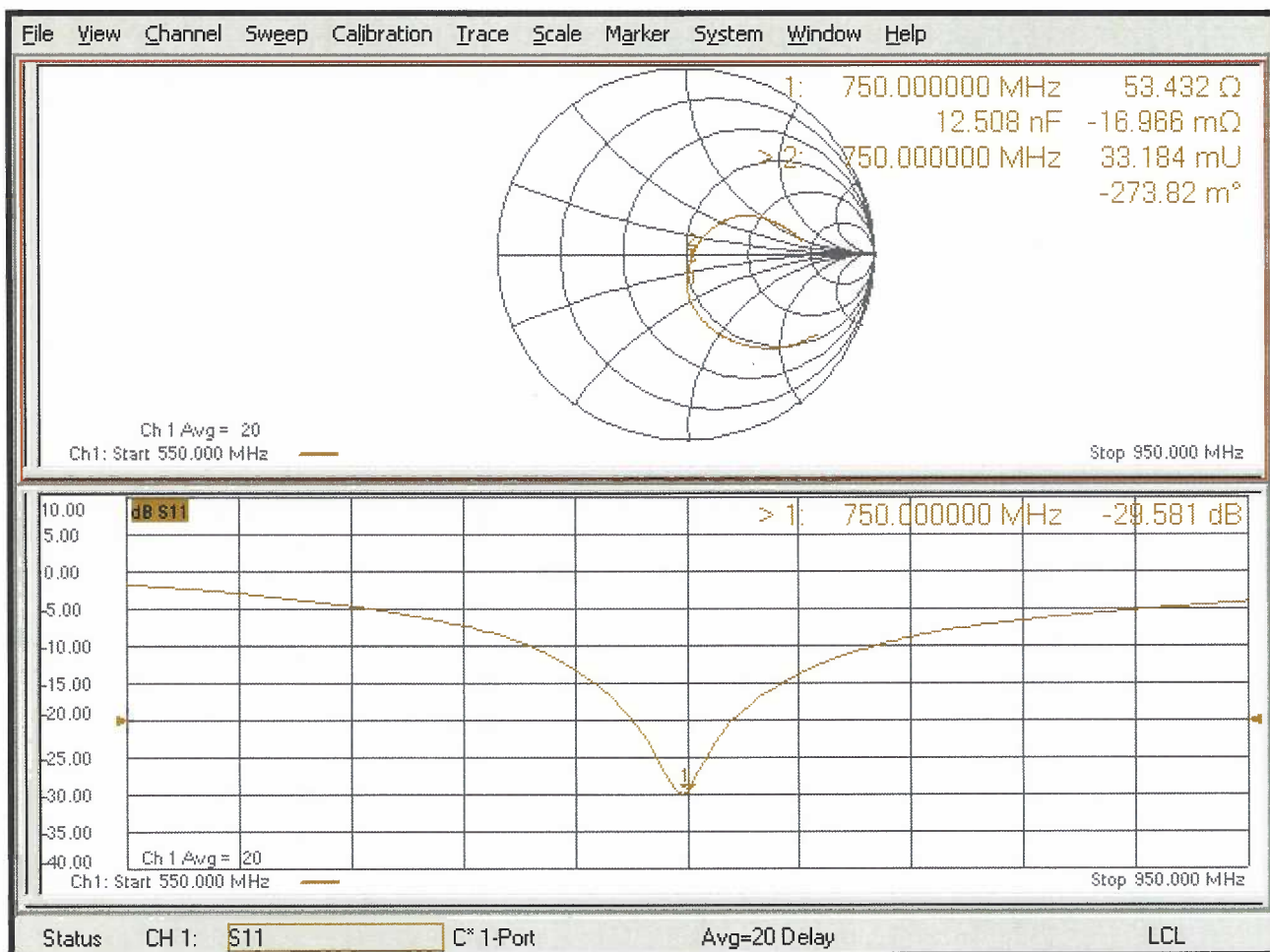

DASY5 Validation Report for Body TSL

Date: 13.07.2018

Test Laboratory: SPEAG, Zurich, Switzerland

DUT: Dipole 750 MHz; Type: D750V3; Serial: D750V3 - SN:1016

Communication System: UID 0 - CW; Frequency: 750 MHz

Medium parameters used: $f = 750$ MHz; $\sigma = 0.96$ S/m; $\epsilon_r = 55.3$; $\rho = 1000$ kg/m³

Phantom section: Flat Section

Measurement Standard: DASY5 (IEEE/IEC/ANSI C63.19-2011)

DASY52 Configuration:

- Probe: EX3DV4 - SN7349; ConvF(10.19, 10.19, 10.19) @ 750 MHz; Calibrated: 30.12.2017
- Sensor-Surface: 1.4mm (Mechanical Surface Detection)
- Electronics: DAE4 Sn601; Calibrated: 26.10.2017
- Phantom: Flat Phantom 4.9 (Back); Type: QD 00R P49 AA; Serial: 1005
- DASY52 52.10.1(1476); SEMCAD X 14.6.11(7439)

Dipole Calibration for Body Tissue/Pin=250 mW, d=15mm/Zoom Scan (7x7x7)/Cube 0:

Measurement grid: dx=5mm, dy=5mm, dz=5mm

Reference Value = 57.68 V/m; Power Drift = -0.03 dB

Peak SAR (extrapolated) = 3.18 W/kg

SAR(1 g) = 2.14 W/kg; SAR(10 g) = 1.41 W/kg

Maximum value of SAR (measured) = 2.84 W/kg

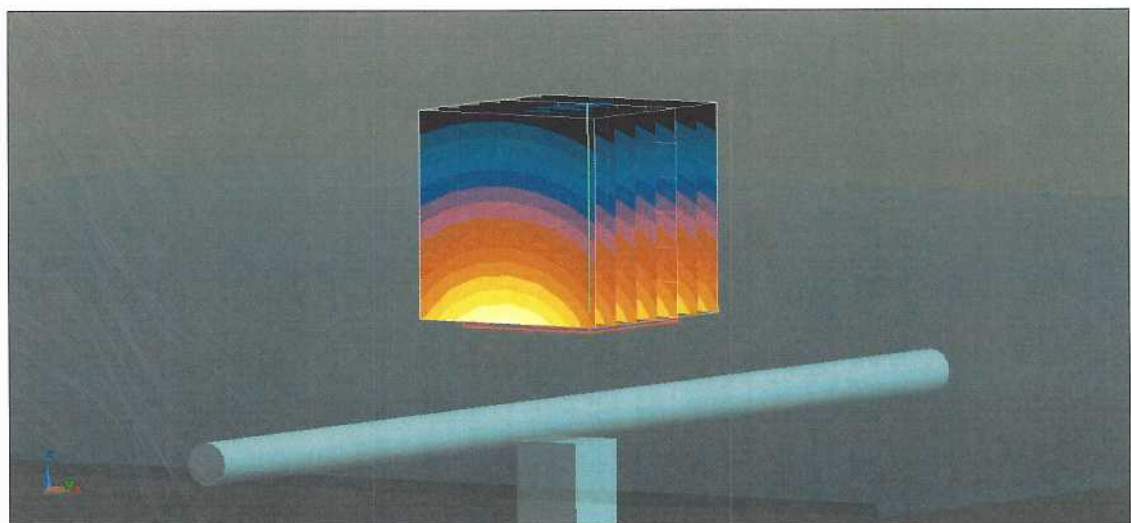
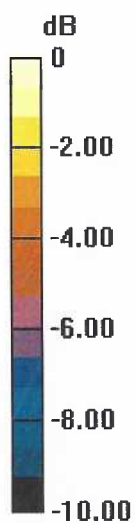

0 dB = 2.84 W/kg = 4.53 dBW/kg

Impedance Measurement Plot for Body TSL

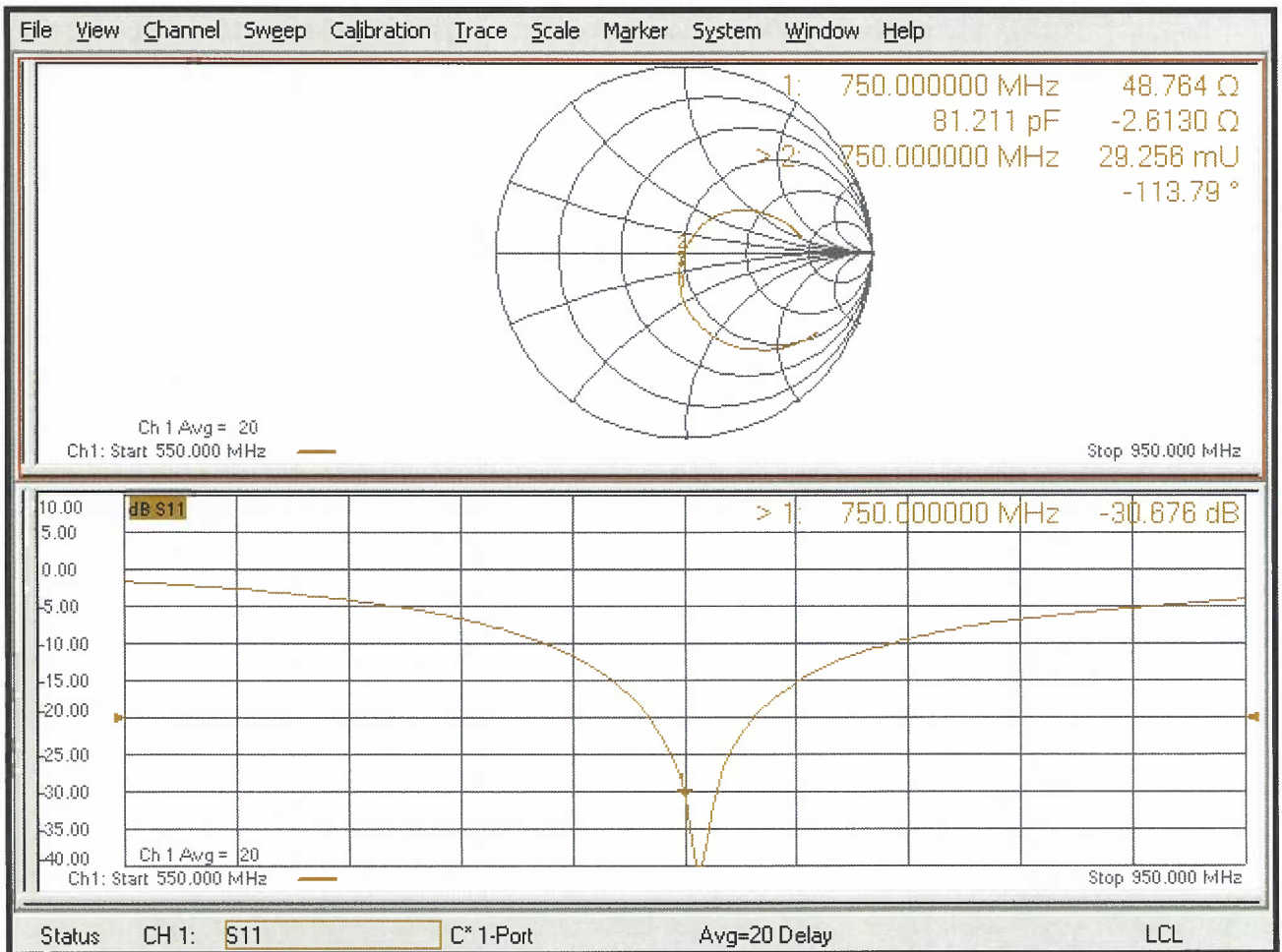



Accredited by the Swiss Accreditation Service (SAS)
The Swiss Accreditation Service is one of the signatories to the EA
Multilateral Agreement for the recognition of calibration certificates

Accreditation No.: **SCS 0108**

Client **RF Exposure Lab**

Certificate No: **D835V2-4d089_Jul18**

CALIBRATION CERTIFICATE

Object **D835V2 - SN:4d089**

Calibration procedure(s) **QA CAL-05.v10
Calibration procedure for dipole validation kits above 700 MHz**

Calibration date: **July 13, 2018**

This calibration certificate documents the traceability to national standards, which realize the physical units of measurements (SI).
The measurements and the uncertainties with confidence probability are given on the following pages and are part of the certificate.

All calibrations have been conducted in the closed laboratory facility: environment temperature (22 ± 3)°C and humidity < 70%.

Calibration Equipment used (M&TE critical for calibration)

Primary Standards	ID #	Cal Date (Certificate No.)	Scheduled Calibration
Power meter NRP	SN: 104778	04-Apr-18 (No. 217-02672/02673)	Apr-19
Power sensor NRP-Z91	SN: 103244	04-Apr-18 (No. 217-02672)	Apr-19
Power sensor NRP-Z91	SN: 103245	04-Apr-18 (No. 217-02673)	Apr-19
Reference 20 dB Attenuator	SN: 5058 (20k)	04-Apr-18 (No. 217-02682)	Apr-19
Type-N mismatch combination	SN: 5047.2 / 06327	04-Apr-18 (No. 217-02683)	Apr-19
Reference Probe EX3DV4	SN: 7349	30-Dec-17 (No. EX3-7349_Dec17)	Dec-18
DAE4	SN: 601	26-Oct-17 (No. DAE4-601_Oct17)	Oct-18

Secondary Standards	ID #	Check Date (in house)	Scheduled Check
Power meter EPM-442A	SN: GB37480704	07-Oct-15 (in house check Oct-16)	In house check: Oct-18
Power sensor HP 8481A	SN: US37292783	07-Oct-15 (in house check Oct-16)	In house check: Oct-18
Power sensor HP 8481A	SN: MY41092317	07-Oct-15 (in house check Oct-16)	In house check: Oct-18
RF generator R&S SMT-06	SN: 100972	15-Jun-15 (in house check Oct-16)	In house check: Oct-18
Network Analyzer Agilent E8358A	SN: US41080477	31-Mar-14 (in house check Oct-17)	In house check: Oct-18

Calibrated by: **Manu Seitz** Name: **Manu Seitz** Function: **Laboratory Technician**

Approved by: **Katja Pokovic** Name: **Katja Pokovic** Function: **Technical Manager**

Signature

Issued: July 17, 2018

This calibration certificate shall not be reproduced except in full without written approval of the laboratory.



Accredited by the Swiss Accreditation Service (SAS)
The Swiss Accreditation Service is one of the signatories to the EA
Multilateral Agreement for the recognition of calibration certificates

Accreditation No.: **SCS 0108**

Glossary:

TSL tissue simulating liquid
ConvF sensitivity in TSL / NORM x,y,z
N/A not applicable or not measured

Calibration is Performed According to the Following Standards:

- a) IEEE Std 1528-2013, "IEEE Recommended Practice for Determining the Peak Spatial-Averaged Specific Absorption Rate (SAR) in the Human Head from Wireless Communications Devices: Measurement Techniques", June 2013
- b) IEC 62209-1, "Measurement procedure for the assessment of Specific Absorption Rate (SAR) from hand-held and body-mounted devices used next to the ear (frequency range of 300 MHz to 6 GHz)", July 2016
- c) IEC 62209-2, "Procedure to determine the Specific Absorption Rate (SAR) for wireless communication devices used in close proximity to the human body (frequency range of 30 MHz to 6 GHz)", March 2010
- d) KDB 865664, "SAR Measurement Requirements for 100 MHz to 6 GHz"

Additional Documentation:

- e) DASY4/5 System Handbook

Methods Applied and Interpretation of Parameters:

- *Measurement Conditions:* Further details are available from the Validation Report at the end of the certificate. All figures stated in the certificate are valid at the frequency indicated.
- *Antenna Parameters with TSL:* The dipole is mounted with the spacer to position its feed point exactly below the center marking of the flat phantom section, with the arms oriented parallel to the body axis.
- *Feed Point Impedance and Return Loss:* These parameters are measured with the dipole positioned under the liquid filled phantom. The impedance stated is transformed from the measurement at the SMA connector to the feed point. The Return Loss ensures low reflected power. No uncertainty required.
- *Electrical Delay:* One-way delay between the SMA connector and the antenna feed point. No uncertainty required.
- *SAR measured:* SAR measured at the stated antenna input power.
- *SAR normalized:* SAR as measured, normalized to an input power of 1 W at the antenna connector.
- *SAR for nominal TSL parameters:* The measured TSL parameters are used to calculate the nominal SAR result.

The reported uncertainty of measurement is stated as the standard uncertainty of measurement multiplied by the coverage factor $k=2$, which for a normal distribution corresponds to a coverage probability of approximately 95%.

Measurement Conditions

DASY system configuration, as far as not given on page 1.

DASY Version	DASY5	V52.10.1
Extrapolation	Advanced Extrapolation	
Phantom	Modular Flat Phantom	
Distance Dipole Center - TSL	15 mm	with Spacer
Zoom Scan Resolution	dx, dy, dz = 5 mm	
Frequency	835 MHz ± 1 MHz	

Head TSL parameters

The following parameters and calculations were applied.

	Temperature	Permittivity	Conductivity
Nominal Head TSL parameters	22.0 °C	41.5	0.90 mho/m
Measured Head TSL parameters	(22.0 ± 0.2) °C	40.7 ± 6 %	0.92 mho/m ± 6 %
Head TSL temperature change during test	< 0.5 °C	----	----

SAR result with Head TSL

SAR averaged over 1 cm³ (1 g) of Head TSL	Condition	
SAR measured	250 mW input power	2.41 W/kg
SAR for nominal Head TSL parameters	normalized to 1W	9.44 W/kg ± 17.0 % (k=2)

SAR averaged over 10 cm³ (10 g) of Head TSL	condition	
SAR measured	250 mW input power	1.55 W/kg
SAR for nominal Head TSL parameters	normalized to 1W	6.10 W/kg ± 16.5 % (k=2)

Body TSL parameters

The following parameters and calculations were applied.

	Temperature	Permittivity	Conductivity
Nominal Body TSL parameters	22.0 °C	55.2	0.97 mho/m
Measured Body TSL parameters	(22.0 ± 0.2) °C	55.2 ± 6 %	0.99 mho/m ± 6 %
Body TSL temperature change during test	< 0.5 °C	----	----

SAR result with Body TSL

SAR averaged over 1 cm³ (1 g) of Body TSL	Condition	
SAR measured	250 mW input power	2.43 W/kg
SAR for nominal Body TSL parameters	normalized to 1W	9.57 W/kg ± 17.0 % (k=2)

SAR averaged over 10 cm³ (10 g) of Body TSL	condition	
SAR measured	250 mW input power	1.58 W/kg
SAR for nominal Body TSL parameters	normalized to 1W	6.24 W/kg ± 16.5 % (k=2)

Appendix (Additional assessments outside the scope of SCS 0108)

Antenna Parameters with Head TSL

Impedance, transformed to feed point	51.6 Ω - 3.3 j Ω
Return Loss	- 28.9 dB

Antenna Parameters with Body TSL

Impedance, transformed to feed point	47.3 Ω - 5.3 j Ω
Return Loss	- 24.3 dB

General Antenna Parameters and Design

Electrical Delay (one direction)	1.391 ns
----------------------------------	----------

After long term use with 100W radiated power, only a slight warming of the dipole near the feedpoint can be measured.

The dipole is made of standard semirigid coaxial cable. The center conductor of the feeding line is directly connected to the second arm of the dipole. The antenna is therefore short-circuited for DC-signals. On some of the dipoles, small end caps are added to the dipole arms in order to improve matching when loaded according to the position as explained in the "Measurement Conditions" paragraph. The SAR data are not affected by this change. The overall dipole length is still according to the Standard.

No excessive force must be applied to the dipole arms, because they might bend or the soldered connections near the feedpoint may be damaged.

Additional EUT Data

Manufactured by	SPEAG
Manufactured on	October 17, 2008

DASY5 Validation Report for Head TSL

Date: 13.07.2018

Test Laboratory: SPEAG, Zurich, Switzerland

DUT: Dipole 835 MHz; Type: D835V2; Serial: D835V2 - SN:4d089

Communication System: UID 0 - CW; Frequency: 835 MHz

Medium parameters used: $f = 835 \text{ MHz}$; $\sigma = 0.92 \text{ S/m}$; $\epsilon_r = 40.7$; $\rho = 1000 \text{ kg/m}^3$

Phantom section: Flat Section

Measurement Standard: DASY5 (IEEE/IEC/ANSI C63.19-2011)

DASY52 Configuration:

- Probe: EX3DV4 - SN7349; ConvF(9.9, 9.9, 9.9) @ 835 MHz; Calibrated: 30.12.2017
- Sensor-Surface: 1.4mm (Mechanical Surface Detection)
- Electronics: DAE4 Sn601; Calibrated: 26.10.2017
- Phantom: Flat Phantom 4.9 (front); Type: QD 00L P49 AA; Serial: 1001
- DASY52 52.10.1(1476); SEMCAD X 14.6.11(7439)

Dipole Calibration for Head Tissue/Pin=250 mW, d=15mm/Zoom Scan (7x7x7)/Cube 0:

Measurement grid: $dx=5\text{mm}$, $dy=5\text{mm}$, $dz=5\text{mm}$

Reference Value = 62.80 V/m; Power Drift = -0.03 dB

Peak SAR (extrapolated) = 3.70 W/kg

SAR(1 g) = 2.41 W/kg; SAR(10 g) = 1.55 W/kg

Maximum value of SAR (measured) = 3.26 W/kg

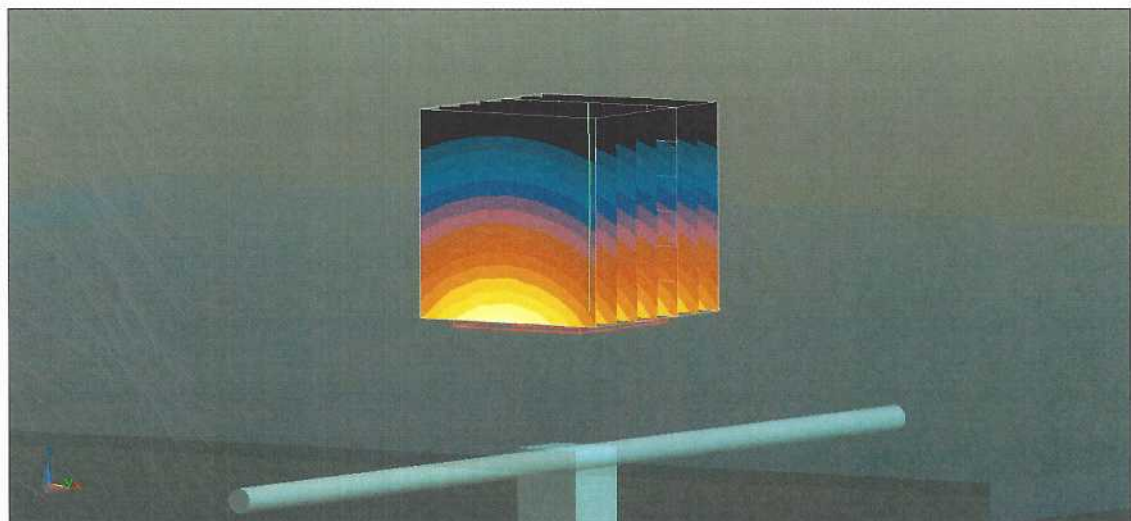
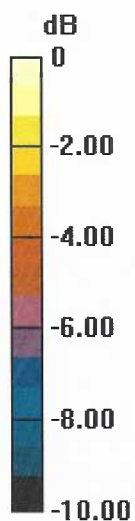

0 dB = 3.26 W/kg = 5.13 dBW/kg

Impedance Measurement Plot for Head TSL

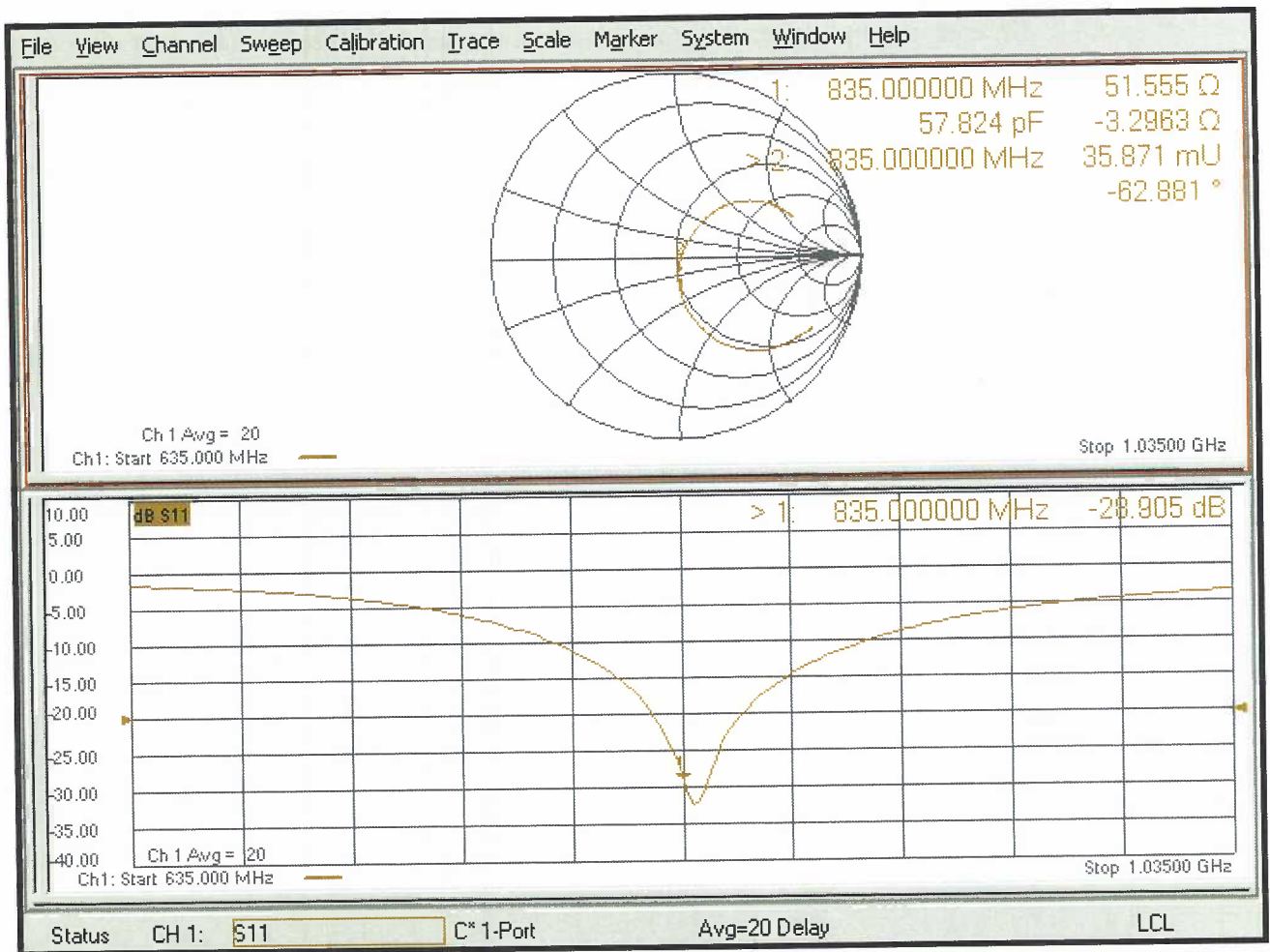

DASY5 Validation Report for Body TSL

Date: 13.07.2018

Test Laboratory: SPEAG, Zurich, Switzerland

DUT: Dipole 835 MHz; Type: D835V2; Serial: D835V2 - SN:4d089

Communication System: UID 0 - CW; Frequency: 835 MHz

Medium parameters used: $f = 835 \text{ MHz}$; $\sigma = 0.99 \text{ S/m}$; $\epsilon_r = 55.2$; $\rho = 1000 \text{ kg/m}^3$

Phantom section: Flat Section

Measurement Standard: DASY5 (IEEE/IEC/ANSI C63.19-2011)

DASY52 Configuration:

- Probe: EX3DV4 - SN7349; ConvF(10.05, 10.05, 10.05) @ 835 MHz; Calibrated: 30.12.2017
- Sensor-Surface: 1.4mm (Mechanical Surface Detection)
- Electronics: DAE4 Sn601; Calibrated: 26.10.2017
- Phantom: Flat Phantom 4.9 (Back); Type: QD 00R P49 AA; Serial: 1005
- DASY52 52.10.1(1476); SEMCAD X 14.6.11(7439)

Dipole Calibration for Body Tissue/Pin=250 mW, d=15mm/Zoom Scan (7x7x7)/Cube 0:

Measurement grid: $dx=5\text{mm}$, $dy=5\text{mm}$, $dz=5\text{mm}$

Reference Value = 60.59 V/m; Power Drift = -0.03 dB

Peak SAR (extrapolated) = 3.60 W/kg

SAR(1 g) = 2.43 W/kg; SAR(10 g) = 1.58 W/kg

Maximum value of SAR (measured) = 3.22 W/kg

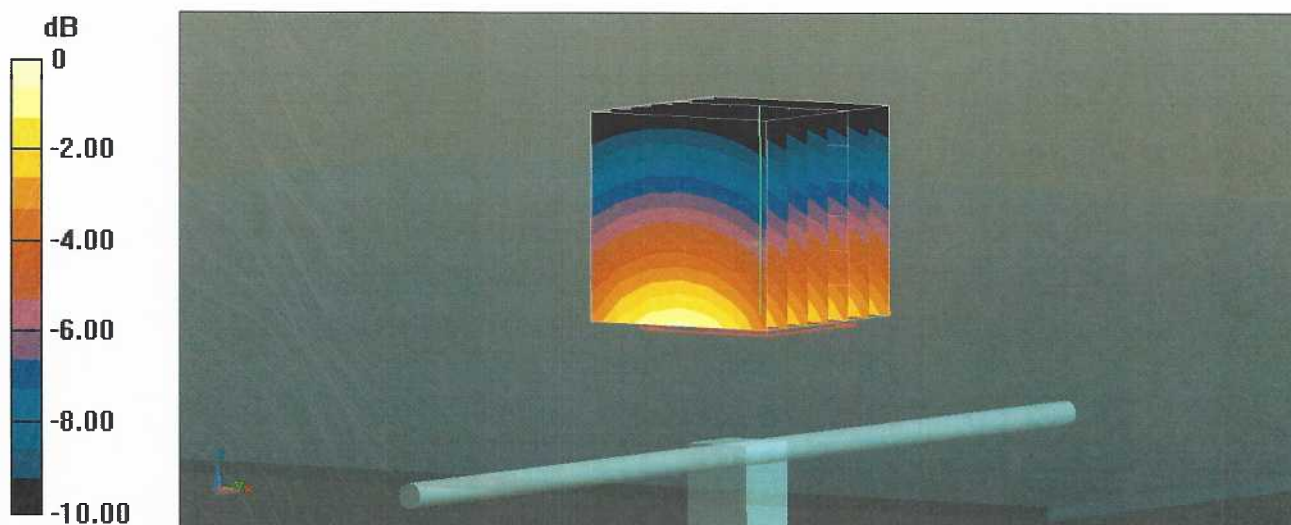

0 dB = 3.22 W/kg = 5.08 dBW/kg

Impedance Measurement Plot for Body TSL

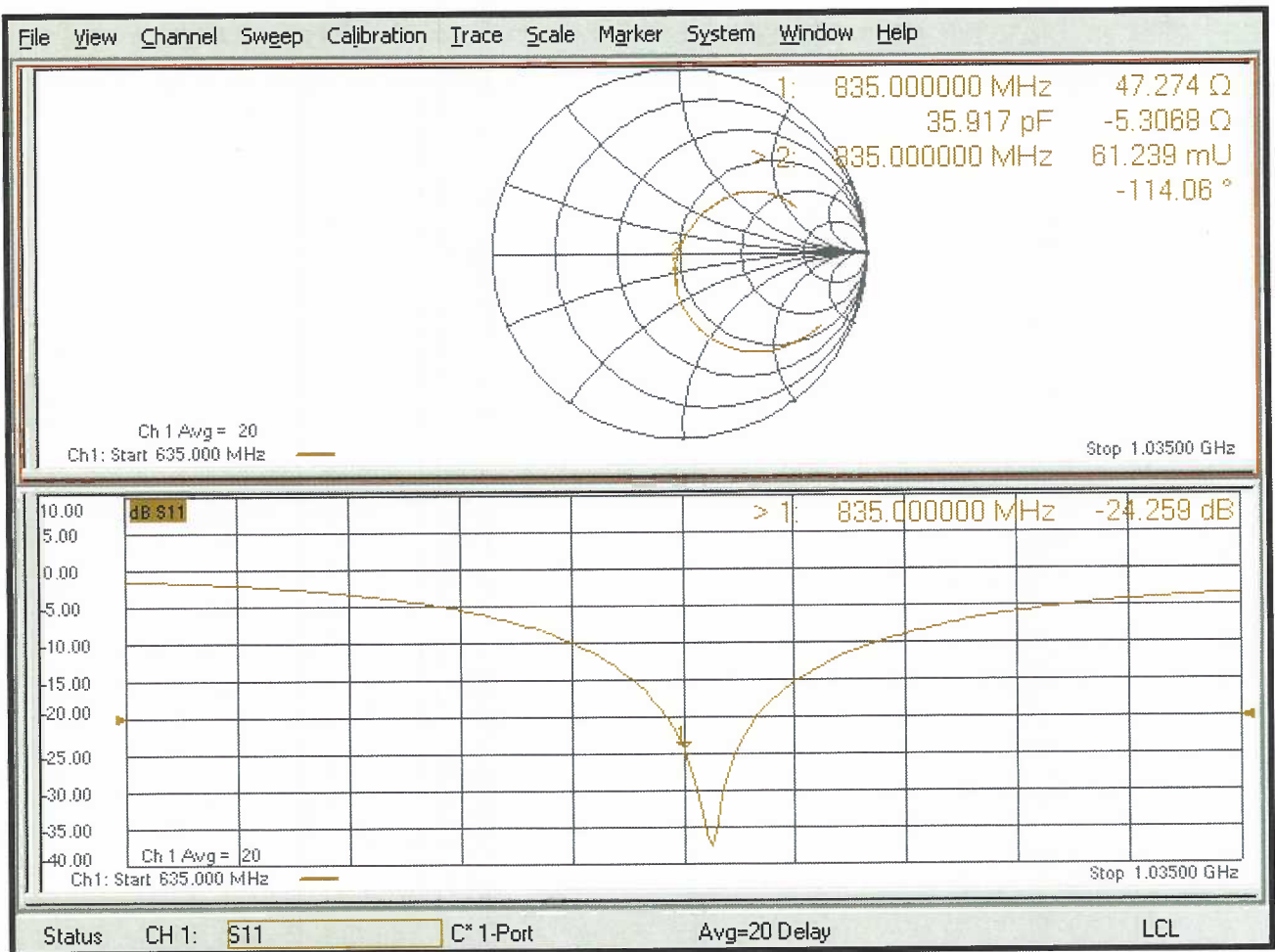



Accredited by the Swiss Accreditation Service (SAS)
The Swiss Accreditation Service is one of the signatories to the EA
Multilateral Agreement for the recognition of calibration certificates

Accreditation No.: **SCS 0108**

Client **RF Exposure Lab**

Certificate No: **D900V2-1d044_Jul18**

CALIBRATION CERTIFICATE

Object **D900V2 - SN:1d044**

Calibration procedure(s) **QA CAL-05.v10
Calibration procedure for dipole validation kits above 700 MHz**

Calibration date: **July 13, 2018**

This calibration certificate documents the traceability to national standards, which realize the physical units of measurements (SI).
The measurements and the uncertainties with confidence probability are given on the following pages and are part of the certificate.

All calibrations have been conducted in the closed laboratory facility: environment temperature (22 ± 3)°C and humidity < 70%.

Calibration Equipment used (M&TE critical for calibration)

Primary Standards	ID #	Cal Date (Certificate No.)	Scheduled Calibration
Power meter NRP	SN: 104778	04-Apr-18 (No. 217-02672/02673)	Apr-19
Power sensor NRP-Z91	SN: 103244	04-Apr-18 (No. 217-02672)	Apr-19
Power sensor NRP-Z91	SN: 103245	04-Apr-18 (No. 217-02673)	Apr-19
Reference 20 dB Attenuator	SN: 5058 (20k)	04-Apr-18 (No. 217-02682)	Apr-19
Type-N mismatch combination	SN: 5047.2 / 06327	04-Apr-18 (No. 217-02683)	Apr-19
Reference Probe EX3DV4	SN: 7349	30-Dec-17 (No. EX3-7349_Dec17)	Dec-18
DAE4	SN: 601	26-Oct-17 (No. DAE4-601_Oct17)	Oct-18
Secondary Standards	ID #	Check Date (in house)	Scheduled Check
Power meter EPM-442A	SN: GB37480704	07-Oct-15 (in house check Oct-16)	In house check: Oct-18
Power sensor HP 8481A	SN: US37292783	07-Oct-15 (in house check Oct-16)	In house check: Oct-18
Power sensor HP 8481A	SN: MY41092317	07-Oct-15 (in house check Oct-16)	In house check: Oct-18
RF generator R&S SMT-06	SN: 100972	15-Jun-15 (in house check Oct-16)	In house check: Oct-18
Network Analyzer Agilent E8358A	SN: US41080477	31-Mar-14 (in house check Oct-17)	In house check: Oct-18

	Name	Function	Signature
Calibrated by:	Manu Seitz	Laboratory Technician	
Approved by:	Katja Pokovic	Technical Manager	

Issued: July 16, 2018

This calibration certificate shall not be reproduced except in full without written approval of the laboratory.



Accredited by the Swiss Accreditation Service (SAS)

The Swiss Accreditation Service is one of the signatories to the EA Multilateral Agreement for the recognition of calibration certificates

Accreditation No.: **SCS 0108**

Glossary:

TSL	tissue simulating liquid
ConvF	sensitivity in TSL / NORM x,y,z
N/A	not applicable or not measured

Calibration is Performed According to the Following Standards:

- IEEE Std 1528-2013, "IEEE Recommended Practice for Determining the Peak Spatial-Averaged Specific Absorption Rate (SAR) in the Human Head from Wireless Communications Devices: Measurement Techniques", June 2013
- IEC 62209-1, "Measurement procedure for the assessment of Specific Absorption Rate (SAR) from hand-held and body-mounted devices used next to the ear (frequency range of 300 MHz to 6 GHz)", July 2016
- IEC 62209-2, "Procedure to determine the Specific Absorption Rate (SAR) for wireless communication devices used in close proximity to the human body (frequency range of 30 MHz to 6 GHz)", March 2010
- KDB 865664, "SAR Measurement Requirements for 100 MHz to 6 GHz"

Additional Documentation:

- DASY4/5 System Handbook

Methods Applied and Interpretation of Parameters:

- Measurement Conditions:** Further details are available from the Validation Report at the end of the certificate. All figures stated in the certificate are valid at the frequency indicated.
- Antenna Parameters with TSL:** The dipole is mounted with the spacer to position its feed point exactly below the center marking of the flat phantom section, with the arms oriented parallel to the body axis.
- Feed Point Impedance and Return Loss:** These parameters are measured with the dipole positioned under the liquid filled phantom. The impedance stated is transformed from the measurement at the SMA connector to the feed point. The Return Loss ensures low reflected power. No uncertainty required.
- Electrical Delay:** One-way delay between the SMA connector and the antenna feed point. No uncertainty required.
- SAR measured:** SAR measured at the stated antenna input power.
- SAR normalized:** SAR as measured, normalized to an input power of 1 W at the antenna connector.
- SAR for nominal TSL parameters:** The measured TSL parameters are used to calculate the nominal SAR result.

The reported uncertainty of measurement is stated as the standard uncertainty of measurement multiplied by the coverage factor $k=2$, which for a normal distribution corresponds to a coverage probability of approximately 95%.

Measurement Conditions

DASY system configuration, as far as not given on page 1.

DASY Version	DASY5	V52.10.1
Extrapolation	Advanced Extrapolation	
Phantom	Modular Flat Phantom	
Distance Dipole Center - TSL	15 mm	with Spacer
Zoom Scan Resolution	dx, dy, dz = 5 mm	
Frequency	900 MHz ± 1 MHz	

Head TSL parameters

The following parameters and calculations were applied.

	Temperature	Permittivity	Conductivity
Nominal Head TSL parameters	22.0 °C	41.5	0.97 mho/m
Measured Head TSL parameters	(22.0 ± 0.2) °C	40.6 ± 6 %	0.95 mho/m ± 6 %
Head TSL temperature change during test	< 0.5 °C	----	----

SAR result with Head TSL

SAR averaged over 1 cm³ (1 g) of Head TSL	Condition	
SAR measured	250 mW input power	2.69 W/kg
SAR for nominal Head TSL parameters	normalized to 1W	10.9 W/kg ± 17.0 % (k=2)

SAR averaged over 10 cm³ (10 g) of Head TSL	condition	
SAR measured	250 mW input power	1.72 W/kg
SAR for nominal Head TSL parameters	normalized to 1W	6.94 W/kg ± 16.5 % (k=2)

Body TSL parameters

The following parameters and calculations were applied.

	Temperature	Permittivity	Conductivity
Nominal Body TSL parameters	22.0 °C	55.0	1.05 mho/m
Measured Body TSL parameters	(22.0 ± 0.2) °C	55.0 ± 6 %	1.01 mho/m ± 6 %
Body TSL temperature change during test	< 0.5 °C	----	----

SAR result with Body TSL

SAR averaged over 1 cm³ (1 g) of Body TSL	Condition	
SAR measured	250 mW input power	2.68 W/kg
SAR for nominal Body TSL parameters	normalized to 1W	11.0 W/kg ± 17.0 % (k=2)

SAR averaged over 10 cm³ (10 g) of Body TSL	condition	
SAR measured	250 mW input power	1.74 W/kg
SAR for nominal Body TSL parameters	normalized to 1W	7.12 W/kg ± 16.5 % (k=2)

Appendix (Additional assessments outside the scope of SCS 0108)

Antenna Parameters with Head TSL

Impedance, transformed to feed point	49.7 Ω - 7.0 j Ω
Return Loss	- 23.1 dB

Antenna Parameters with Body TSL

Impedance, transformed to feed point	45.0 Ω - 8.1 j Ω
Return Loss	- 20.0 dB

General Antenna Parameters and Design

Electrical Delay (one direction)	1.410 ns
----------------------------------	----------

After long term use with 100W radiated power, only a slight warming of the dipole near the feedpoint can be measured.

The dipole is made of standard semirigid coaxial cable. The center conductor of the feeding line is directly connected to the second arm of the dipole. The antenna is therefore short-circuited for DC-signals. On some of the dipoles, small end caps are added to the dipole arms in order to improve matching when loaded according to the position as explained in the "Measurement Conditions" paragraph. The SAR data are not affected by this change. The overall dipole length is still according to the Standard.

No excessive force must be applied to the dipole arms, because they might bend or the soldered connections near the feedpoint may be damaged.

Additional EUT Data

Manufactured by	SPEAG
Manufactured on	September 26, 2006